



# *HYDRONIC* II-H\*

Troubleshooting and repair instructions

Eberspächer

J. Eberspächer  
GmbH & Co. KG  
Eberspächerstr. 24  
D-73730 Esslingen

Telefon (zentral)  
(07 11) 9 39-00  
Telefax  
(07 11) 9 39-05 00

[www.eberspaecher.com](http://www.eberspaecher.com)

**The troubleshooting and repair instructions are valid  
for the following engine-independent water heater:**

*HYDRONIC* II-H

Order no.

D 5 S-H – 12 V

25 2337 05 00 00

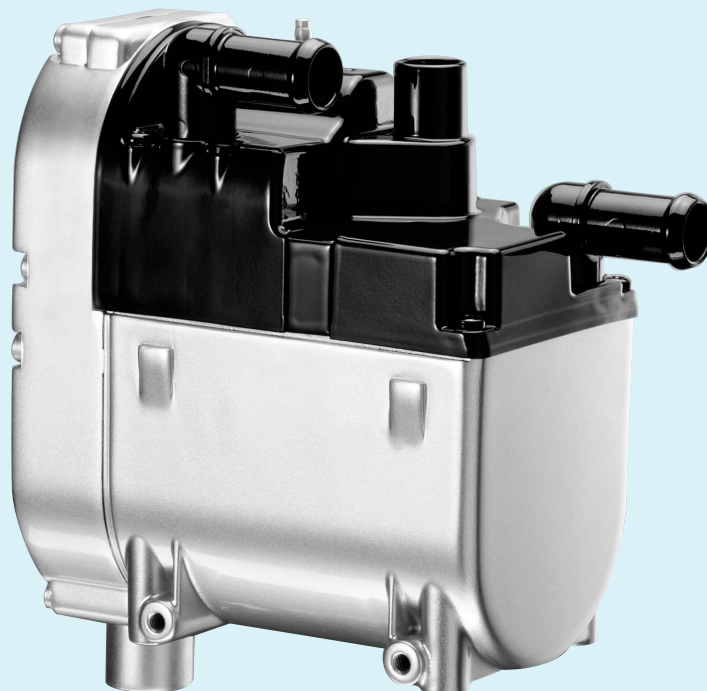

# 1 Introduction

## Contents

These contents provide you with the exact information about the contents of the troubleshooting and repair instructions.

If you are looking for a phrase or technical term or need an explanation for an abbreviation, please use the corresponding index at the end of the instructions from page 36.

Chapter	Chapter title	Chapter contents	Page
1	Introduction	<ul style="list-style-type: none"> <li>• Special forms of notation, presentation and icons ..... 4</li> <li>• Liability / Guarantee ..... 4</li> <li>• Accident prevention ..... 4</li> <li>• Important information               <ul style="list-style-type: none"> <li>– Range of application ..... 4</li> <li>– Purpose ..... 4</li> <li>– Initial commissioning respectively function test following repairs ..... 4</li> </ul> </li> <li>• <i>HYDRONIC II-H</i> documentation               <ul style="list-style-type: none"> <li>– Contents and purpose of these troubleshooting and repair instructions ..... 5</li> <li>– Other <i>HYDRONIC II-H</i> documentation ..... 5</li> </ul> </li> <li>• Statutory regulations ..... 5               <ul style="list-style-type: none"> <li>– Directive 2001/56/EU of the European Parliament and the Council ..... 5</li> </ul> </li> <li>• Safety instructions for installation and repair ..... 6</li> <li>• Accident prevention ..... 6</li> </ul>	
2	Function and operation	<ul style="list-style-type: none"> <li>• Operating instructions ..... 7</li> <li>• Important instructions for operation ..... 7</li> <li>• Description of functions ..... 7</li> <li>• Heating at high altitudes ..... 7</li> <li>• Control and safety features ..... 8</li> <li>• Emergency shut-down (EMERGENCY OFF) ..... 8</li> <li>• Function diagram ..... 9</li> <li>• Control diagram ..... 9</li> </ul>	
3	Technical data	<ul style="list-style-type: none"> <li>• Heater ..... 10</li> <li>• Water pump ..... 11</li> </ul>	
4	Troubleshooting	<ul style="list-style-type: none"> <li>• When faults occur, first check ..... 12</li> <li>• Controller lock ..... 12</li> <li>• Cancel the controller lock ..... 12</li> <li>• Testing equipment ..... 12</li> <li>• Fault diagnosis with diagnosis instrument ..... 13, 14</li> <li>• Error code table ..... 15 – 18</li> </ul>	



Chapter	Chapter title	Chapter contents	Page
5	Repair instructions	<ul style="list-style-type: none"> <li>• Repair instructions ..... 19</li> <li>• Observe following safety instructions before working on the heater ..... 19</li> <li>• Instructions for AMP unlocking tool ..... 19</li> <li>• Assembly drawing ..... 20, 21</li> <li>• Repair step 1 Dismantle jacket cover ..... 22</li> <li>• Repair step 2 Dismantle control and overheating sensor ..... 22 Check control and overheating sensor ..... 23</li> <li>• Repair step 3 Dismantle surface sensor ..... 23 Check surface sensor ..... 24</li> <li>• Repair step 4 Dismantle controller ..... 24</li> <li>• Repair step 5 Remove glow plug ..... 25 Replace seals ..... 25</li> <li>• Repair step 6 Remove flame sensor ..... 26 Check flame sensor ..... 26</li> <li>• Repair step 7a Dismantle combustion air fan ..... 27</li> <li>• Repair step 7b Measure speed of combustion air fan motor ..... 27</li> <li>• Repair step 8 Remove combustion chamber ..... 28</li> <li>• Repair step 9 Remove heat exchanger ..... 28</li> <li>• Repair step 10 Re-mount heat exchanger ..... 29</li> <li>• Measuring the fuel quantity ..... 29</li> </ul>	
6	Wiring diagram	<ul style="list-style-type: none"> <li>• Wiring diagram <i>HYDRONIC II-H</i> ..... 30, 31</li> </ul>	
7	Wiring diagram	<ul style="list-style-type: none"> <li>• Certification ..... 32</li> <li>• Disposal ..... 32</li> <li>• Foreign representatives ..... 33, 34</li> <li>• List of abbreviations ..... 35</li> <li>• Keyword index ..... 36</li> </ul>	

# 1 Introduction

## Special forms of notation, presentations and icons

These instructions use special forms of notation and icons to underline various different contents. Please refer to the examples below for the meaning and how to behave.

### Special forms of notation and presentations

- This point (•) indicates a list introduced by a heading.
  - If a “dot” is followed by an indented hyphen (–), this list is classified under the black dot.

### Icons



#### Regulation

This icon refers you to a statutory regulation. Failure to comply can possibly lead to the ABG (general type certification) for the heater becoming null and void and to the preclusion of any guarantee or liability on the part of J. Eberspächer GmbH & Co. KG.



#### Danger

This icon draws your attention to a threat of danger to life and limb. Failure to comply can possibly lead to severe personal injury.



#### Caution

This icon draws your attention to a dangerous situation for a person and / or product. Failure to comply can result in injury to persons or damage to the machine.

#### Please note

This draws your attention to recommendations and helpful tips for operation, installation and repair of the heater.

## Liability / guarantee

Compliance with the official regulations and safety instructions is a prerequisite for any liability claims. Failure to comply with the official regulations and safety instructions precludes any liability on the part of the heater manufacturer.

## Accident prevention

General accident prevention regulations and corresponding workshop and operational protection instructions must always be observed.

## Important information

### Range of application of the heater

The engine-independent water heater is intended for installation in the following vehicles, depending on heater output:

- motorised vehicles of all kinds
- construction machines
- boats, ships and yachts (diesel heaters only).



#### Caution

- The heater may only be used and operated for the range of application stated by the manufacturer in full compliance with the “operating instructions” enclosed with every heater.
- The heater must **not** be installed in vehicles used for the transport of dangerous substances as per ADR / ADR99-

### Purpose of the heater

- Preheating, de-misting windows
- Heating the following and keeping them warm:
  - Driver or working cab
  - Freight compartments
  - Ship’s cabins
  - Passenger and crew compartments
  - Vehicle engines and additional units.

Given its functional purpose, the heater is **not** certified for the following uses:

- Long-term continuous operation, e.g. pre-heating and heating of:
  - Living areas
  - Garages
  - Working sheds, weekend houses and hunting cottages
  - Houseboats, etc

### Initial commissioning of the heater respectively function test following repairs

- After installation of the heater respectively after repairs to the heater, the coolant circuit and the whole fuel supply system must be carefully vented. Please comply with the instructions issued by the vehicle manufacturer.
- Prior to a trial run, open all heating circuits (set the temperature control to “warm”).
- During the trial run of the heater, check that all water and fuel connections do not leak and are firmly connected.
- If the heater should show a malfunction during operation, eliminate the problem with a diagnosis device.



# 1 Introduction

## HYDRONIC Documentation

### Content and purpose of these troubleshooting and repair instructions

These instructions are to be used for eliminating faults and performing repairs on the heater.

The necessary work must only be carried out by a JE partner or correspondingly trained staff.

### Other HYDRONIC documentation

### Operating instructions

The operating instructions give the customer all necessary information for safe operation of the heater.

### Technical description / Installation instructions

The technical description/installation instructions give the JE partner all necessary technical information and describe correct proper installation of the heater.

### Spare parts list

The spare parts list gives the JE partner all necessary information for ordering spare parts required for repair work.

## Statutory regulations

The Federal Vehicle Office has awarded an "EU Type Permit" with an official test symbol for installation of the heater in motorised vehicles, shown on the heater nameplate.

HYDRONIC II-H  00 0024



## Regulation

### Directive 2001/56/EU of the European Parliament and the Council

#### • Arrangement of the heater

- Parts of the structure and other components near the heater must be protected from excess heat exposure and possible contamination from fuel or oil.
- The heater must not pose a fire hazard even when it overheats. This requirement is deemed to be fulfilled when adequate clearance to all parts is observed during installation, sufficient ventilation is provided and fire-proof materials or heat plates are used.
- The heater must not be located in the passenger compartment in vehicles of class M<sub>1</sub>, M<sub>2</sub>, M<sub>3</sub> and N. A unit may however be used in a hermetically sealed housing which also corresponds to the conditions stated above.
- The factory nameplate or duplicate must be affixed so that it can still be easily read when the heater is installed in the vehicle.

- All appropriate precautions must be taken when arranging the heater to minimise the risk of injuries to persons or damage to other property.

#### • Fuel supply

- The fuel intake connection must not be located in the passenger compartment and must be sealed with a properly closing lid to prevent any fuel leaks.
- In heaters for liquid fuel where the heater fuel is separate from the vehicle fuel, the type of fuel and intake connection must be clearly identified.
- A warning sign is to be fixed to the intake connection indicating that the heater must be switched off before refuelling.

#### • Exhaust system

- The exhaust outlet must be arranged so as to prevent any penetration of exhaust fumes into the vehicle interior through the ventilation system, warm air intakes or open windows.

#### • Combustion air intake

- The air for the heater combustion chamber must not be sucked in from the passenger compartment of the vehicle.
- The air intake must be arranged or protected in such a way that it cannot be blocked by other objects.

#### • Operating status display

- A clearly visible operating display in the user's field of vision must indicate when the heater is switched on and off.

#### Please note

- Compliance with the statutory regulations and safety instructions is prerequisite for guarantee and liability claims. Failure to comply with the statutory regulations and safety instructions and incorrect repairs even when using original spare parts make the guarantee null and void and preclude any liability for J. Eberspächer GmbH & Co. KG.
- The statutory regulations are binding and must also be observed in countries which do not have any special regulations.

# 1 Introduction

---

## Safety instructions for installation and operation



### Danger

Risk of injury, fire and poisoning

- Disconnect the vehicle battery before starting any kind of work.
- Before working on the heater, switch the heater off and let all hot components cool down.
- The heater must not be operated in enclosed rooms, e.g. in the garage or multi-storey car park.



### Caution

#### Safety instructions for installation and operation

- The heater must only be installed by a JE partner authorised by the manufacturer according to the instructions in this manual and possibly according to special installation recommendations; the same applies to any repairs to be carried out in the case of repairs or guarantee claims.
- Repairs by non-authorised third-parties or with not original spare parts are dangerous and therefore not allowed. They result in expiry of the type permit of the heater; consequently, when installed in motor vehicles they can cause expiry of the vehicle operating licence.
- The following measures are not allowed:
  - Changes to components relevant to the heater
  - Use of third-party components not approved by Eberspächer
  - Nonconformities in installation or operation from the statutory regulations, safety instructions or specifications relevant to safe operation as stated in the installation instructions and operating instructions. This applies in particular to the electrical wiring, fuel supply, combustion air system and exhaust system.
- Only original accessories and original spare parts must be used during installation or repairs.
- Only the controls approved by Eberspächer may be used to operate the heater. The use of other controls can result in malfunctions.
- Before the heater is installed again in another vehicle, rinse the heater parts carrying water with clear water.

- When carrying out electric welding on the vehicle, the plus pole cable at the battery should be disconnected and placed at ground to protect the controller.
- The heater must not be operated where there is a risk of an accumulation of flammable vapours or dust, for example close to
  - fuel depot
  - coal depot
  - wood depot
  - grain depots etc.
- The heater must be switched off when refuelling.
- When the heater is mounted in a safety housing etc., the installation compartment of the heater is not a stowage compartment and must be kept clear. In particular fuel canisters, oil cans, spray cans, gas cartridges, fire extinguishers, cleaning rags, items of clothing, paper etc. must not be stored or transported on or next to the heater.
- Defect fuses must only be replaced by fuses with the prescribed rating.
- If fuel leaks from the heater fuel system, arrange for the damage to be repaired immediately by a JE service partner.
- When topping up the coolant, only use the coolant permitted by the vehicle manufacturer, see the vehicle operating manual. Any blending with unpermitted coolant can cause damage to the engine and heater.
- After-running of the heater must not be interrupted prematurely e.g. by pressing the battery disconnecting switch, apart from in the case of an emergency stop.

## Accident prevention

General accident prevention regulations and the corresponding workshop and operation safety instructions are to be observed.



## 2 Function and operation

### Operating instructions

If the supply of warmth by the vehicle motor at the warm up, at the city traffic or bank up is too less, the heater automatically starts and supports the vehicle heating.

### Important instructions for operation

#### Safety checks before the start

After a longer interval in operations (after the summer months) the fuse must be put in position and / or the heater connected up to the battery. Check that all parts fit firmly (tighten screws where necessary).

Check the fuel system visually for any leaks.

### Description of functions

#### Switching on (auxiliary heating mode)

When the vehicle motor is switched ON, the heater starts at the same time, on condition that the temperature at the temperature switch  $< 5\text{ }^{\circ}\text{C}$ . The heater can also be switched manually by a separate switch (option).

The combustion air fan, glow plug, dosing pump and water pump are started according to a specified program sequence.

Once a stable flame has formed in the combustion chamber, the glow plug is switched off with time control.

#### Heating mode

The heater starts in the "large" stage.

Once the cooling water temperature has reached approx.  $80\text{ }^{\circ}\text{C}$  - depending on the selected can setting - the heater changes over to the "small" stage.

- If the heat provided in the "small" stage is not sufficient, the cooling water temperature falls to  $75\text{ }^{\circ}\text{C}$  - the heater then changes over to the "large" stage again.
- If the heat provided in the "small" stage is sufficient, then the cooling water temperature increases to  $85\text{ }^{\circ}\text{C}$ . Following a delay of approx. 120 seconds, the heater then switches off (pause stage).

If the cooling water has cooled down to  $75\text{ }^{\circ}\text{C}$  in the pause stage, then the system starts up again in the "large" stage.

### Heating at high altitudes

When using the heater at high altitudes, please note:

- Heating at altitudes up to 1500 m:
  - Unlimited heating possible
- Heating at altitudes over 1500 mm:
  - Heating is possible for short periods at this altitude (e.g. driving over a mountain pass or taking a break in a journey)
  - Heating is not possible for longer periods at this altitude (e.g. winter camping).
  - After consulting the manufacturer, a special dosing pump is rated specifically for heating at high altitudes can be purchased from the manufacturer.

## 2 Function and operation

---

### Control and safety devices

#### The heater is equipped with the following control and safety devices:

- If the heater does not ignite within 90 seconds after starting the fuel pump, the start is repeated. If the heater still does not ignite after another 90 seconds, the heater is switched off. After an unacceptable number of failed start attempts (10 times), the controller is locked.\*
- If the flame goes off by itself during operation, the heater is restarted. If the heater does not ignite within 90 seconds after the fuel pump has started again, or it ignites but goes out again within 15 minutes, the heater is switched off. This status can be remedied by briefly switching off and on again (ignition ON/OFF).
- In the case of overheating (e.g. lack of water, poorly vented coolant circuit), the overheating sensor triggers, the fuel supply is interrupted and the heater switched off.  
Once the cause of overheating has been eliminated, the heater can be started again by switching off and on again (ignition ON/OFF). This is on condition that the heater has cooled down sufficiently, cooling water temperature <70 °C. After an unacceptable number of failed start attempts (10 times), the controller is locked\*.
- The heater is switched off if the upper or lower voltage limit is reached.
- The heater does not start up when the glow plug is defect or when the electric lead to the dosing pump is interrupted.
- The speed of the fan motor is monitored continuously. If the fan motor does not start up or is blocked, the heater is switched off after 120 sec.

\* The controller can be enabled again and the faults read off:

- by connecting up a diagnosis unit

Operation and fault list, please refer to page 12 – 18.

#### Please note

Do not switch the heater off and on again more than twice.

#### Emergency shutdown – EMERGENCY OFF

If an emergency shutdown – EMERGENCY OFF – is necessary during operation, proceed as follows:

- Switch the heater off with the control or
- Pull the fuse out or
- Disconnect the heater from the battery.





## 2 Function and operation

### Function diagram

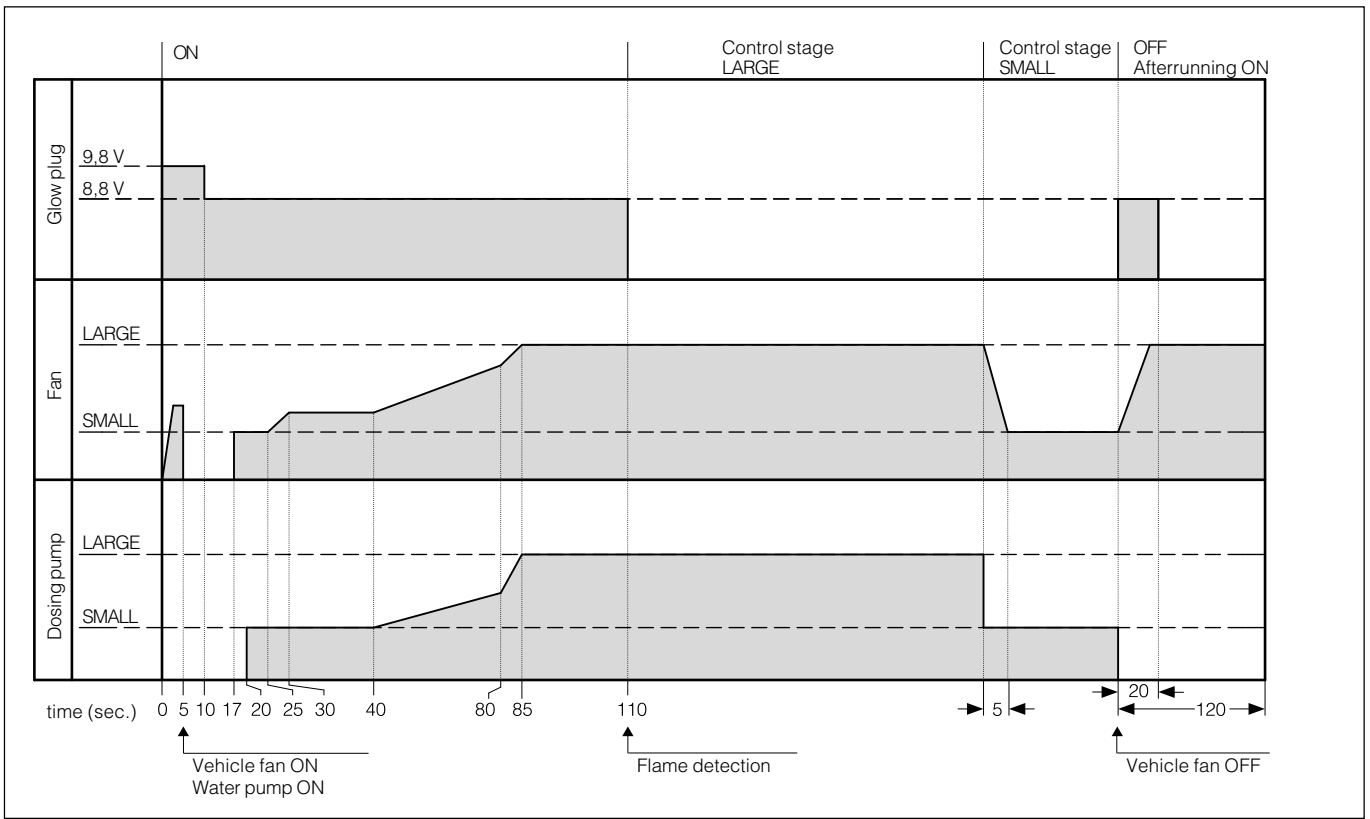

### Sectional drawing

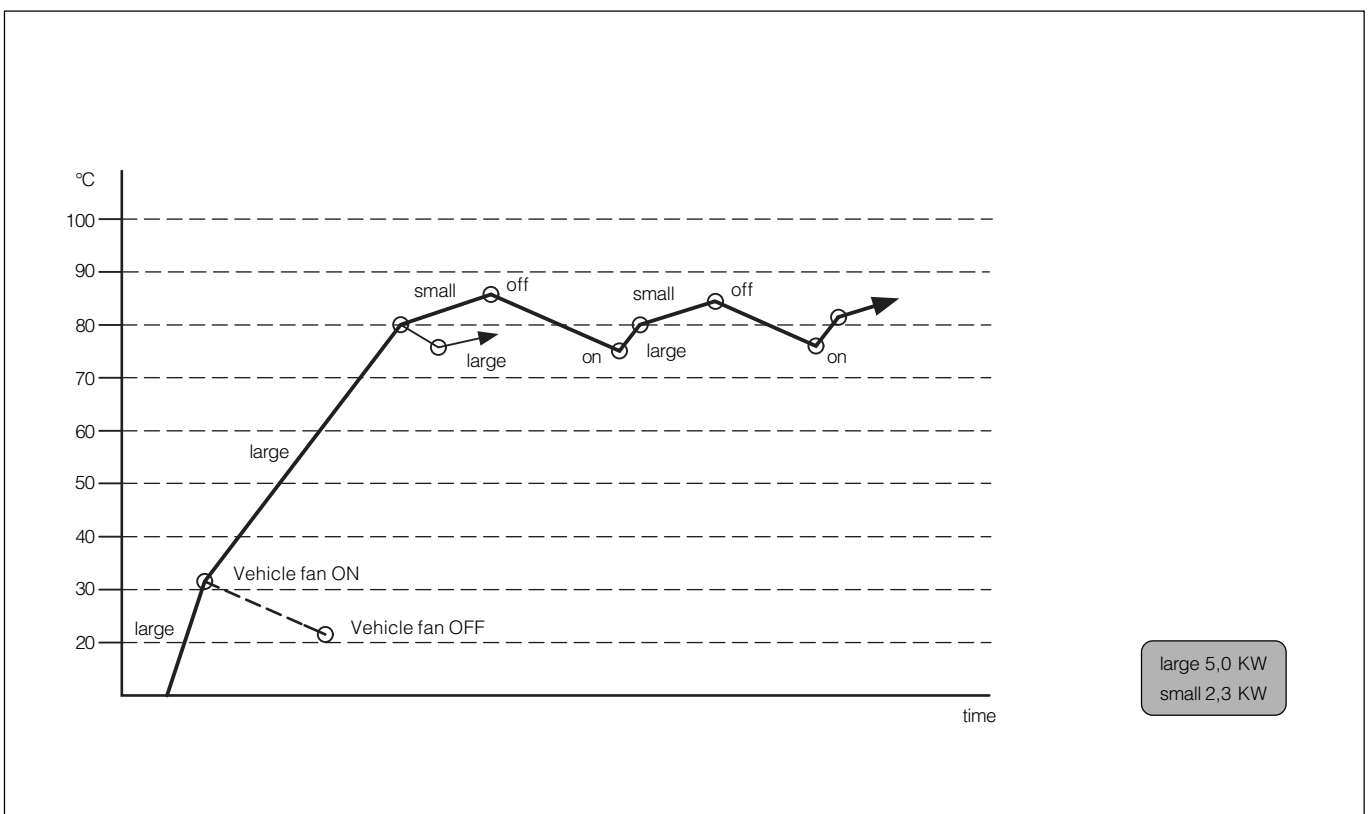

### 3 Technical data

#### HYDRONIC II-H

Heater	D 5 S-H	
Heating medium	Water, coolant	
Control of heat flow	Large	Small
Heat flow (watt)	5000	2300
Fuel consumption (l/h)	0,62	0,27
Mean electr. power consumption (watt)	in operation	35
	at start	100
	after-running	12
Rated voltage	12 volt	
Operating range	10 volt	
	<ul style="list-style-type: none"> <li>Lower voltage limit An undervoltage protection device switches the heaters off at approx. 10 volt</li> </ul>	
<ul style="list-style-type: none"> <li>Upper voltage limit An overvoltage protection device switches the heaters off at approx. 16 volt</li> </ul>		16 volt
Tolerable operating pressure	up to 2.5 bar overpressure	
Minimum water flow through the heater	250 l/h	
Fuel	petrol – commercially available (DIN EN 228)	
Tolerable ambient temperature	operation	-40°C to +80°C
	storage	-40°C to +105°C (2h for 125 °C)
Degree of interference suppression DIN 57879 / Part 1 VDE 0879	5 (or 4 for long shaft, depending on motor)	
Weight: without cooling liquid and mounted parts	approx. 2.3 kg	



#### Caution

##### Safety instructions for the technical datas

The stated technical data must be complied to prevent malfunctions.

All technical data ±10 %



### 3 Technical data

#### Technical data – water pump

Rated voltage	12 volt
Operating voltage	9 volt bis 15 volt
Electrical power consumption	16 Watt
Pumping capacity against 0.1 bar	800 l/h
Operating temperature	-40 °C bis +135 °C
Weight	0.28 kg

All technical data  $\pm 10$  %



#### Caution

The stated technical data must be complied to prevent malfunctions.

#### Pump curve Water pump – 12 volt

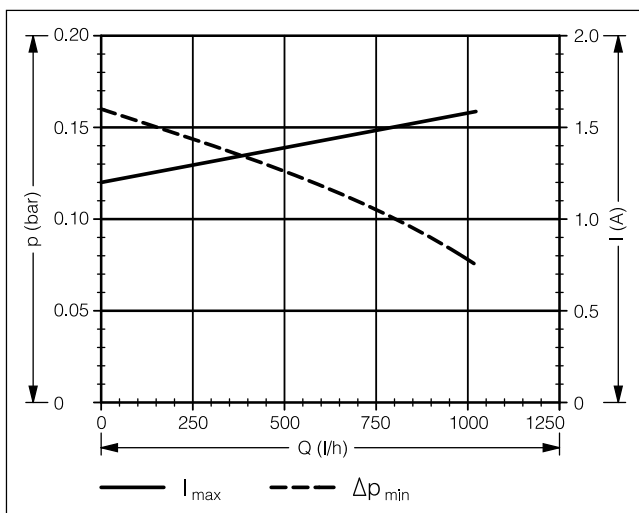

## 4 Troubleshooting

---

### When faults occur, first check ...

- Faulty wiring?  
(short circuits, interruptions)
- Visual check for
  - corroded contacts
  - defect fuses
  - damaged electrical leads, links and connections
  - damaged exhaust and combustion air guidance
- Check battery voltage  
Battery voltage < 10 volt:  
the undervoltage protection has triggered.
- Check fuel supply:  
Is there fuel in the tank?
- When changing over to winter operations:  
Is there still summer diesel in the pipes?
- **Check voltage supply  $U_{\text{batt}}$  (terminal 30)**  
Disconnect the 10-pole connection S1 / B1 and measure the voltage present in connector B1 between chamber 2 and chamber 1 . For deviations in the battery voltage, check the fuses, supply lines, ground connection and plus point on battery for loss of voltage (corrosion / interruption) (see circuit diagram and connector configuration page 30).
- **Check switch-on signal (D+)**  
Disconnect the 10-pin connector S1/B1 and then start the vehicle engine.  
Measure the voltage in connector B1 between chamber 6 and chamber 2.  
If there is no voltage, check the power supply lead, then connector B1, chamber 7 (see circuit diagram and connector configuration page 30)..

#### Please note

Heater starts

- at an outside temperature < 5°C
- at a cooling water temperature < 70°C

### Controller lock

The controller is locked when the following faults occur:

- **Overheating**  
If the heater overheats 10 times in succession, error code 015 appears --> the controller is locked.
- **Too many start attempts**  
If the heater performs 10 start attempts in vain, error code 050 appears --> the controller is locked.

### Cancel the controller lock

Cancelling the controller lock depends on the corresponding testing equipment and is described on page 14.

## 4 Troubleshooting

### Fault diagnosis with the diagnosis instrument

Diagnosis instrument  
Order no. 22 1529 89 00 00

An adapter cable is necessary to connect up the diagnosis instrument

Adapter cable  
Order no. 22 1000 32 64 00

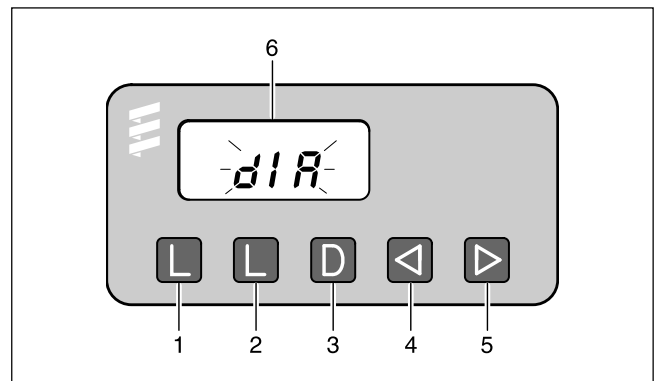

- ① Button **L** – delete fault memory
- ② Button **L** – delete fault memory
- ③ Button **D** – switch heater on / off  
request diagnosis
- ④ Button **◀** – backwards, fault F5 – F1, AF
- ⑤ Button **▶** – forwards, fault AF, F1 – F5
- ⑥ Display

The electronic controller of the heater can save up to 5 faults, which can be read and displayed with the diagnosis instrument.

The current fault is shown as “AF” and a 2-digit number and always written in memory place F1. Previous faults are transferred to memory places F2 to F5, and the contents of memory place F5 are overwritten.

#### Connecting up the diagnosis instrument

- Disconnect the 8-pole connector from the the heater cable harness and connect the adapter cable.
- Then connect the diagnosis instrument to the adapter cable.

The display shows:

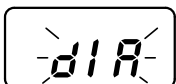

#### Querying the fault memory

- Press the button **D** on the diagnosis unit to switch on the heater.

The display shows:

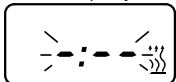

- After 8 secs, the display shows:



no error

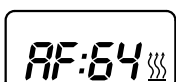

current fault (e.g. error code 64)

Error code, fault description, cause and remedies are described on pages 15 to 18.

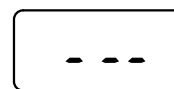

Fault diagnosis not possible

Possible causes:

- adapter cable not connected properly
- controller defect or not capable of diagnosis (not a universal controller).

#### Display of fault memory F1 – F5 or F5 – F1

- Press the buttons **◀** or **▶** once or several times to show the individual fault memories in decreasing or increasing order. The display shows:

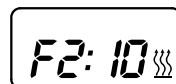

e.g. fault memory 2 / error code 10

Only those fault memories occupied by a fault are shown.

#### Please note

If it is not possible to query the diagnosis at the heater, the vehicle motor may have to be started.

## 4 Troubleshooting

### Controller lock

- Overheating:  
If the heater overheats 10 times in succession, fault 012, AF 015 appears in the display, i.e. the controller is locked.
- Too many start attempts:  
If the heater performs 10 start attempts in vain, fault 052, AF 050 appears in the display, i.e. the controller is locked.

### Cancelling the controller lock

- Delete the fault memory as described and switch off the heater with button **D**.
- The controller lock is cancelled and the diagnosis finished.

The display shows:

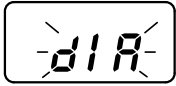

### Delete fault memory

- Eliminate cause of fault.
- Press both buttons **L** at the same time until the display shows:

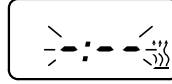

- Once the fault memories are deleted, the last current fault is shown. The current fault is not reset to 00 until the next restart of the heater, insofar as no other current fault has occurred. The display shows:



no faults

### Please note

Not only a defect component but also a defect current path results in a display.

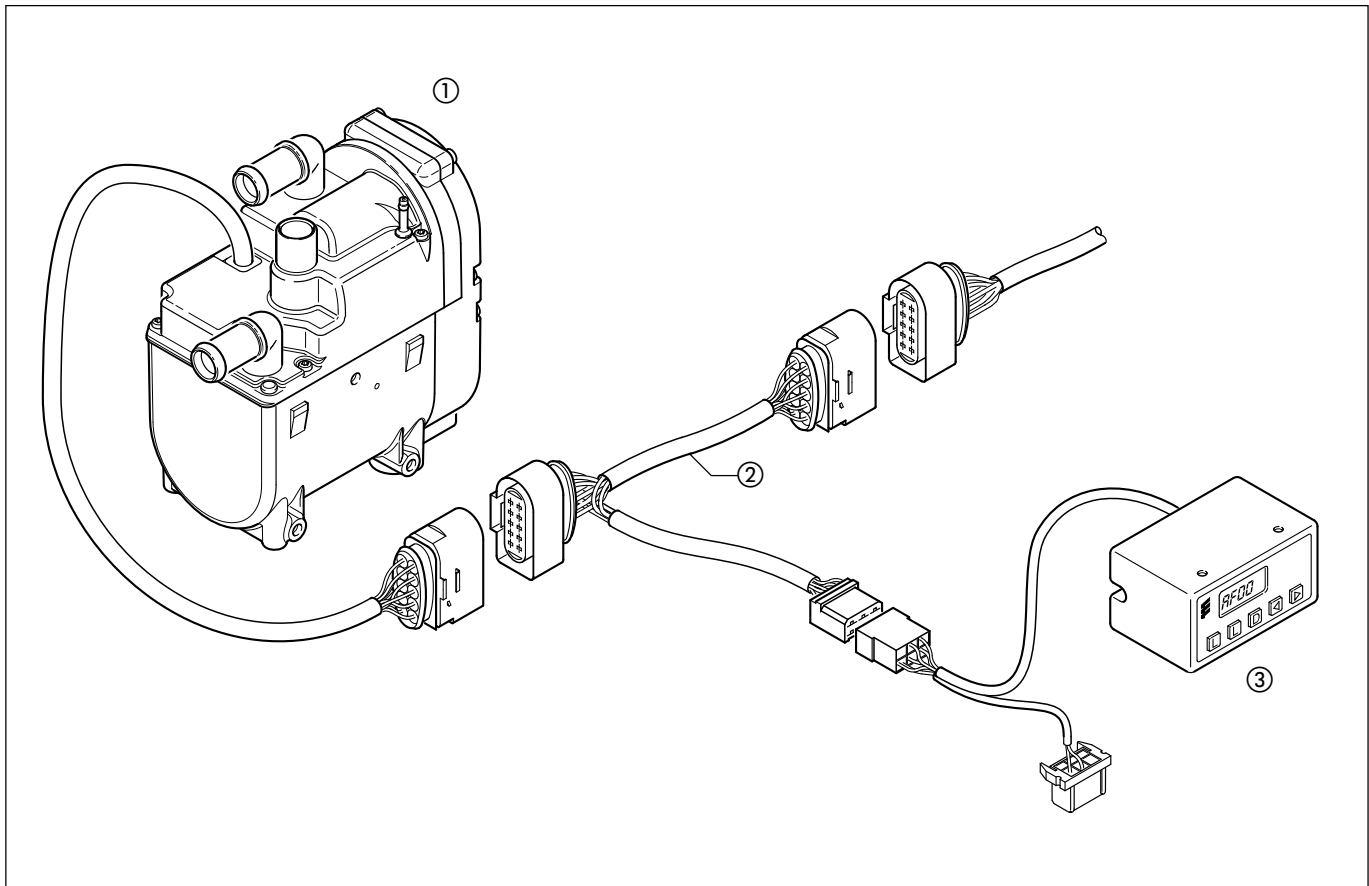

- ① Heater
- ② Adapter cable
- ③ Diagnosis instrument

## 4 Troubleshooting



Error code Display	Fault description	Explanations • Remedies
0	No fault	
10	Shutdown because of overvoltage	<ul style="list-style-type: none"> <li>• Measure battery voltage (must be &lt;15.9V).</li> <li>• Check dynamo</li> </ul>
11	Shutdown because of undervoltage	<ul style="list-style-type: none"> <li>• Measure battery voltage (must be &gt;10.2V under load)</li> <li>• Check dynamo</li> <li>• Check lead (terminal 30, terminal 31)</li> </ul>
12	Overheating (software – threshold value)	<p>Temperature at surface sensor &gt; 125°C.</p> <ul style="list-style-type: none"> <li>• Check water circuit; <ul style="list-style-type: none"> <li>– Check all hoses for any leaks</li> <li>– Is there a throttle in the water circuit?</li> <li>– Is the water circuit properly vented?</li> <li>– Check functions of water pump</li> </ul> </li> <li>• Check temperature sensor and overheating sensor (Control values see page 23 and 24), replace if necessary</li> </ul>
14	Overheating – differential evaluation	<p>Difference in temperature values of surface sensor and control and overheating sensor too intense. Prerequisite for this error code is that the heater is operating and the water temperature at the overheating sensor has reached min. 80°C.</p> <ul style="list-style-type: none"> <li>• Check water circuit: <ul style="list-style-type: none"> <li>– Check all hoses for any leaks.</li> <li>– Is there a throttle in the water circuit?</li> <li>– Is the water circuit properly vented?</li> <li>– Check functions of water pump.</li> </ul> </li> <li>• Check control and overheating sensor (Control values see page 23 and 24), replace if necessary.</li> </ul>
15	Overheating – Operation lock	<p>Controller is locked</p> <ul style="list-style-type: none"> <li>• Unlock controller by deleting fault memory</li> <li>• Check water circuit <ul style="list-style-type: none"> <li>– Check all hoses for any leaks</li> <li>– Is there a throttle in the water circuit?</li> <li>– Is the water circuit properly vented?</li> <li>– Check functions of water pump.</li> </ul> </li> </ul>
16	Difference evaluation 2	<p>If the surface sensor shows a far higher temperature value than the control and overheating sensor (Control values see page 23 and 24), this results in a fault shutdown.</p>
17	Overheating – Hardware	<p>Temperature at control and overheating sensor &gt; 130°C.</p> <ul style="list-style-type: none"> <li>• Check water circuit: <ul style="list-style-type: none"> <li>– Check all hoses for any leaks.</li> <li>– Is there a throttle in the water circuit?</li> <li>– Is the water circuit properly vented?</li> <li>– Check functions of water pump.</li> </ul> </li> <li>• Check temperature sensor and overheating sensor (Control values see page 23 and 24), replace if necessary.</li> </ul>
20	Interruption – glow plug	<ul style="list-style-type: none"> <li>• Check the cable harness of this component for damage and continuity (14-pole connector, chamber 13 and 14) replace component if necessary.</li> <li>• Check plug-in connection, replace component if necessary.</li> </ul>

## 4 Troubleshooting

Error code Display	Fault description	Explanations • Remedies
21	Short circuit, overload or accidental ground glow plug output	<ul style="list-style-type: none"> <li>Check the cable hardness of this component for damage (14-pole connector, chamber 13 and 14), replace component if necessary.</li> </ul>
22	Defect glow plug output	<ul style="list-style-type: none"> <li>Check component lead for short circuit to +Ub, if not, check component for ground fault (14-pole connector, chamber 13 and 14), if necessary replace controller.</li> </ul>
25	Short circuit K-line	<ul style="list-style-type: none"> <li>Check diagnosis line for damage</li> </ul>
30	Speed of combustion fan motor outside tolerance range.	<ul style="list-style-type: none"> <li>Fan impeller of combustion air fan motor blocked (frozen, dirty, stiff).</li> <li>Remove blockage.</li> <li>Measure speed of combustion air fan motor (page 27)</li> </ul>
31	Burner motor – interruption	<ul style="list-style-type: none"> <li>Check the cable harness of this component for damage and continuity (14-pole connector, chamber 13 and 14), replace component if necessary.</li> <li>Check plug-in connection, replace component if necessary.</li> </ul>
32	Short circuit, overload or accidental ground Burner motor	<ul style="list-style-type: none"> <li>Fan impeller of combustion air fan motor blocked (frozen, dirty, stiff).</li> <li>Check the cable harness of this component for damage and continuity (14-pole connector, chamber 13 and 14), replace component if necessary.</li> </ul>
34	Burner motor output defect	<ul style="list-style-type: none"> <li>Check component lead for short circuit to GND, if not, check component for ground fault (14-pole connector, chamber 13 and 14), if necessary replace controller.</li> </ul>
36	Vehicle fan output defect (only for pre-heater)	<ul style="list-style-type: none"> <li>Check component lead for short circuit to +Ub, if necessary replace controller.</li> </ul>
39	Overload, short-circuit or ground fault in vehicle fan	<ul style="list-style-type: none"> <li>Check the cable harness to the externe component for damage, replace component if necessary.</li> </ul>
41	Water pump interruption	<ul style="list-style-type: none"> <li>Check the cable harness to the external component at the 10-pin connector for damage and continuity.</li> <li>Check plug-in connection, replace external component if necessary.</li> </ul>
42	Overload, short-circuit or ground fault Water pump	<ul style="list-style-type: none"> <li>Check the cable hardness to the externe component at the 10-pin connector for damage continuity.</li> </ul>
43	Water pump output defect	<ul style="list-style-type: none"> <li>Check the component lead for short circuit to GND, if not, check component at 10-pin connector B1 for ground fault, replace controller if necessary.</li> </ul>
47	Overload, short-circuit or ground fault Dosing pump	<ul style="list-style-type: none"> <li>Check the cable harness to the externe component at 14-pin connector for damage, replace component if necessary.</li> </ul>
48	Dosing pump interruption	<ul style="list-style-type: none"> <li>Check the cable harness to the extern component at 14-pin connector for damage and continuity</li> <li>Check plug-in connection, replace the externe component if necessary.</li> </ul>
49	Dosing pump output defect	<ul style="list-style-type: none"> <li>Check component lead for short circuit to GND, if not, check component at 14-pin connector for ground fault, if necessary replace controller.</li> </ul>





## 4 Troubleshooting

Error code Display	Fault description	Explanations • Remedies
50	Operation lock because of too many failed starting attempts (10 starting attempts, also start repetition for every starting attempt)	Too many starting attempts, controller locked. <ul style="list-style-type: none"> <li>• Unlock controller by deleting fault memory</li> <li>• Check fuel quantity (measurement see p. 29) and fuel supply.</li> </ul>
51	Time exceeded – blowing cold	At start, flame sensor reports too long a high temperature value (no flame formation). <ul style="list-style-type: none"> <li>• Check exhaust and combustion air guidance.</li> <li>• Check flame sensor (control values see page 29).</li> </ul>
52	Safety time exceeded	<ul style="list-style-type: none"> <li>• Check exhaust and combustion air guidance.</li> <li>• Check fuel quantity (measurement see p. 29) and fuel supply.</li> <li>• Clean or replace filter in dosing pump connection.</li> </ul>
54 56	Flame aborted from control stage “large” Flame aborted from control stage “small”	<p><b>Warning</b> After flame aborted from control stage “large” or “small” and after starting attempt within allowed number, the heater proceeds with a new start, where applicable with subsequent start repeat. If the new start or start repeat is successful, the error code is deleted.</p> <p><b>Error</b></p> <ul style="list-style-type: none"> <li>• Check exhaust and combustion air guidance.</li> <li>• Check fuel quantity (measurement see p. 29) and fuel supply.</li> <li>• Check flame sensor, see error code 064 and 065.</li> </ul>
60	Interruption control and overheating sensor	<ul style="list-style-type: none"> <li>• Check the cable harness of this component for damage and continuity.</li> <li>• Check plug-in connection.</li> <li>• Check sensor resistance, replace component if necessary (control values see page 23).</li> </ul>
61	Overload or ground fault control and overheating sensor	<ul style="list-style-type: none"> <li>• Check the cable harness of this component for damage and continuity.</li> <li>• Check sensor resistance, replace component if necessary (control values see page 23).</li> </ul>
64	Interruption flame sensore	<ul style="list-style-type: none"> <li>• Check the cable harness of this component for damage and continuity.</li> <li>• Check plug-in connection.</li> <li>• Check sensor resistance, replace component if necessary (control values see page 26).</li> </ul>
65	Short circuit surface sensor	<ul style="list-style-type: none"> <li>• Check the cable harness of this component for damage and continuity.</li> <li>• Check sensor resistance, replace component if necessary (control values see page 26).</li> </ul>
71	Interruption surface sensor	<ul style="list-style-type: none"> <li>• Check the cable harness of this component for damage and continuity.</li> <li>• Check plug-in connection.</li> <li>• Check sensor resistance, replace component if necessary (control values see page 24).</li> </ul>

## 4 Troubleshooting

<b>Error code Display</b>	<b>Fault description</b>	<b>Explanations</b> <b>• Remedies</b>
72	Short circuit surface sensor	<ul style="list-style-type: none"><li>• Check the cable harness of this component for damage and continuity.</li><li>• Check sensor resistance, replace component if necessary (control values see page 24).</li></ul>
74	Overheating hardware defect, operation block	<ul style="list-style-type: none"><li>• Replace controller.</li></ul>
90	Watch Dog Reset	<ul style="list-style-type: none"><li>• Replace controller.</li></ul>
91	too many Resets	<ul style="list-style-type: none"><li>• Replace controller.</li></ul>
92	ROM-fault	<ul style="list-style-type: none"><li>• Replace controller.</li></ul>
93	RAM-fault	<ul style="list-style-type: none"><li>• Replace controller.</li></ul>
94	Too many transistor faults – operation block	<ul style="list-style-type: none"><li>• Repair component overload to +UB, GND, if necessary replace controller.</li></ul>
95	Software Stack Overflow	<ul style="list-style-type: none"><li>• Replace controller.</li></ul>
96	Not a valid sequence, operating block	<ul style="list-style-type: none"><li>• Replace controller.</li></ul>
97	Defect resonator/quartz, incorrect processor cycle	<ul style="list-style-type: none"><li>• Replace controller.</li></ul>
98	Main relay defect	<ul style="list-style-type: none"><li>• Replace controller.</li></ul>
99	EEPROM-fault	<ul style="list-style-type: none"><li>• Replace controller.</li></ul>

## 5 Repair instructions

### Repair instructions

The chapter “repair instructions” describes the repair and servicing work allowed at the heater. These repair instructions look in detail at the petrol respectively diesel version where the repair steps differ. It is recommended to remove the heater from the vehicle for extensive repair work.

The heater is always re-assembled in the reverse order; note additional instructions where given.

#### Please note

A function test must always be performed after completing all work on the heater (see page 4).

### Before working on the heater, please comply with the following safety instructions:



#### Danger!

#### Risk of injury, burning and poisoning!

- Always switch the heater off beforehand and allow to cool down.
- Disconnect the battery.
- Release overpressure in the cooling system by opening the radiator cap.
- The heater may not be operated in closed rooms such as garages or workshops.

Exception:

when there is a device to extract the exhaust directly from the opening of the exhaust pipe.

#### Please note

- Seals from removed parts must be replaced.
- During repair work, check all parts for any signs of damage and replace where necessary.
- Check connector contacts, connections and leads for corrosion and any signs of damage, and repair where necessary.
- If spares are needed, only original Eberspächer spare parts may be used.
- After working on the coolant circuit, check the level of coolant. If necessary, top up with coolant according to the instructions issued by the vehicle manufacturer. Then vent the coolant circuit.
- Operation or after-running of the heater may only be stopped in an emergency (see EMERGENCY STOP page 8) by interrupting the current from the battery (risk of overheating).

### AMP unlocking tool

The AMP unlocking tool is used for detaching receptacles from a connector housing.

This unlocking tool can be ordered direct from Eberspächer GmbH & Co. KG

- For all parts apart from glow plug:  
Micro-Timer order no. 206 00 205
- For glow plug:  
Junior-Power-Timer order no. 206 00 204



AMP unlocking tool

# 5 Repair instructions

## Assembly drawing

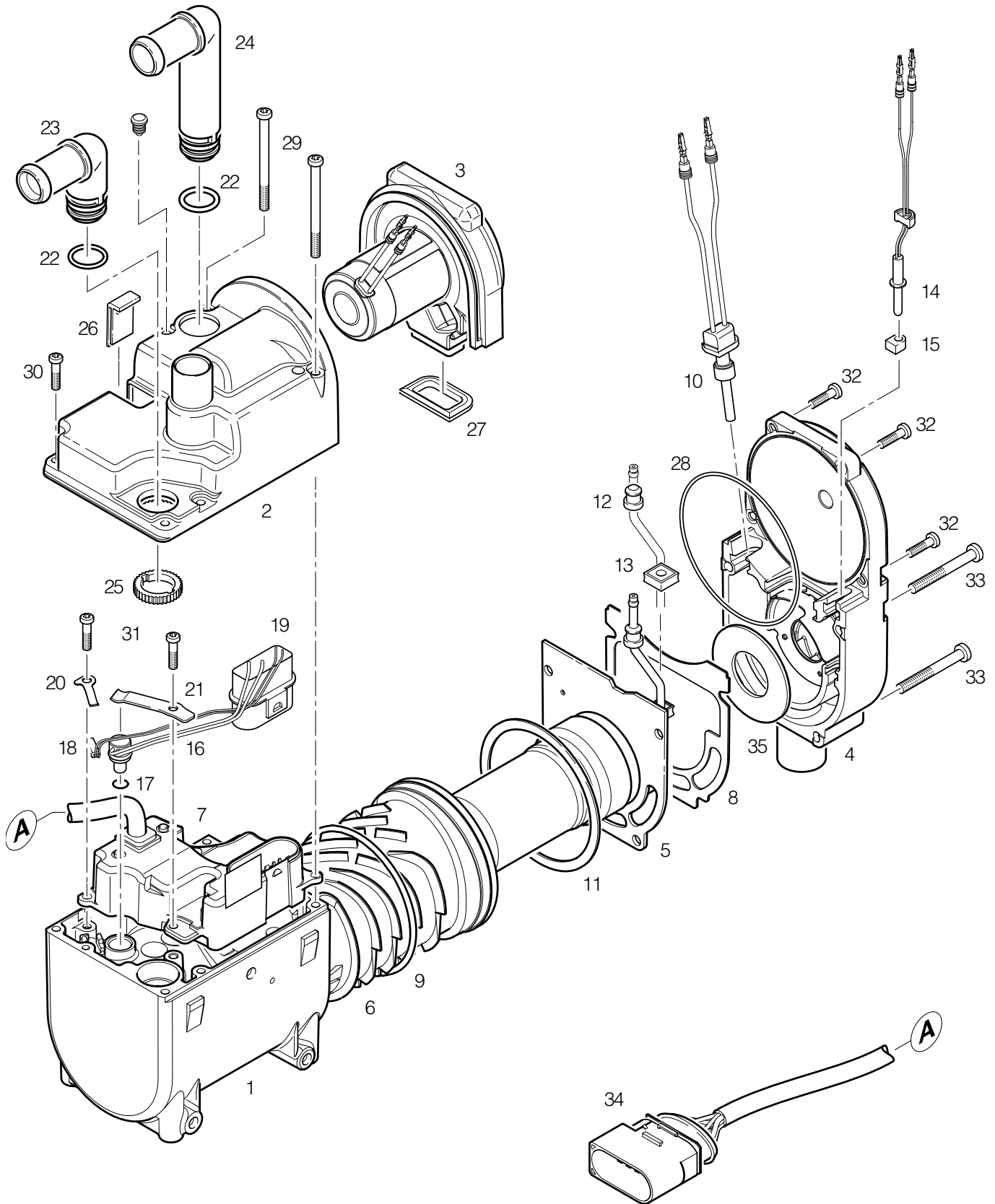



## 5 Repair instructions

---

### Parts list

- 1 Jacket
- 2 Jacket cover
- 3 Combustion air fan
- 4 Combustion chamber
- 5 Combustion chamber with flame tube
- 6 Heat exchanger
- 7 Controller
- 8 Seal between combustion chamber and combustion air fan
- 9 O-ring
- 10 Glow plug with cable
- 11 Seal between combustion chamber and heat exchanger
- 12 Upper bush for fuel pipe
- 13 Lower bush for fuel pipe
- 14 Flame sensor
- 15 Graphite bush for flame sensor
- 16 Control and overheating sensor with cable
- 17 O-ring
- 18 Surface sensor with cable
- 19 Controller connector – 14-pole connector for controller (waterproof)
- 20 Holding spring for surface sensor
- 21 Holding spring for control and overheating sensor
- 22 O-ring
- 23 Water connection (water in)
- 24 Water connection (water out)
- 25 Toothed ring (2x)
- 26 Cable harness cover
- 27 Rectangular rubber seal
- 28 O-ring
- 29 Screw Taptite M4 x 55 TORX (2x)
- 30 Screw Taptite M4 x 16 TORX (2x)
- 31 Screw Taptite M4 x 12 TORX (2x)
- 32 Screw Taptite M4 x 16 TORX (4x)
- 33 Screw Taptite M5 x 44 TORX (4x)
- 34 Cable harness for the controller
- 35 Insulation washer

# 5 Repair instructions

## Repair step 1

### Dismantle jacket cover

- Loosen the 4 screws fastening the cover.
- Pull the cable harness cover up and out of the jacket cover, the cable harness for the connector is then exposed.
- Pull the water connection up and carefully pull the cover over the fuel connection.
- During assembly, fix the toothed rings of the two water connections in the jacket cover.
- Place the jacket cover carefully over the fuel connection onto the jacket.
- Insert and tighten the 4 screws fastening the cover.

Torques:

Long fastening screws,  $3.3^{+0.3}$  Nm

Short fastening screws,  $2.4^{+0.3}$  Nm

#### Please note

- The two water connections of the jacket cover are sealed in the jacket with O-rings.
- Check and if necessary replace the O-rings before re-assembly.
- Check that the water connections are in the right position.

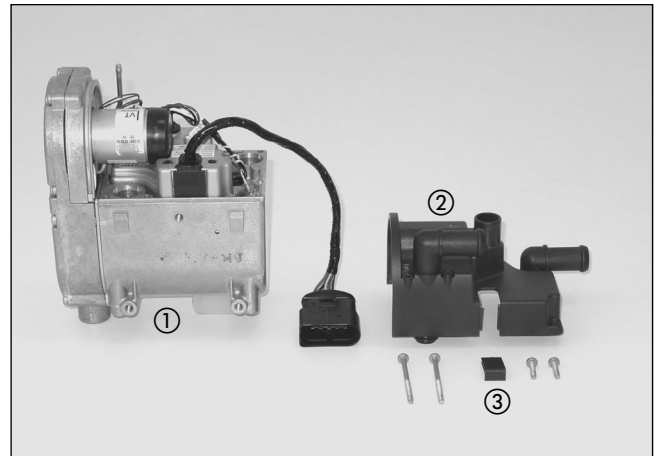

Fig. 1

- ① Jacket
- ② Jacket cover
- ③ Cable harness cover

## Repair step 2

### Dismantle control and overheating sensor

- Perform repair step 1, dismantle jacket cover.
- Loosen the screws fastening the holding spring and remove the holding spring.
- Pull the control and overheating sensor out of the receptacle bore in the jacket using flat pliers.
- Unfasten and disconnect the 14-pole connector at the controller.
- Using the unlocking tool, unclip the two cables from the control and overheating sensor in the 14-pin connector (chamber 10, cable  $0.5^2$  black and chamber 11, cable  $0.5^2$  black).

When mounting the cable harness for the control and overheating sensor, twist twice around the cable harness of the surface sensor

Torque fastening screws holding spring:  $3.3^{+0.3}$  Nm

#### Please note

- Ensure that the cables are routed correctly (see fig. 2a).
- The control and overheating sensor with cable harness is one component and not available as individual parts if spares are required.
- Lubricate with special grease (e.g. „Hellerine“) when fitting the O-ring of the control and overheating sensor.

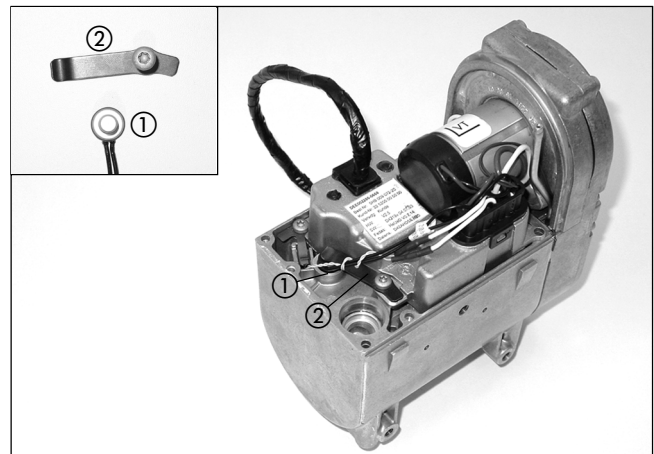

Fig. 2

- ① Control and overheating sensor
- ② Holding spring

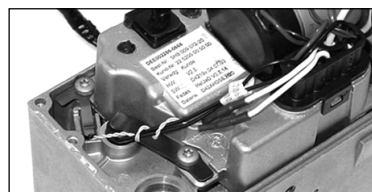

Fig. 2a: Routing the cables for the control and overheating sensor

## 5 Repair instructions



### Check control and overheating sensor

(Diagram 1)

Check the control and overheating sensor with a digital multimeter. If the resistance value of the flame sensor is **outside** the table of values respectively diagram, then the flame sensor must be replaced.

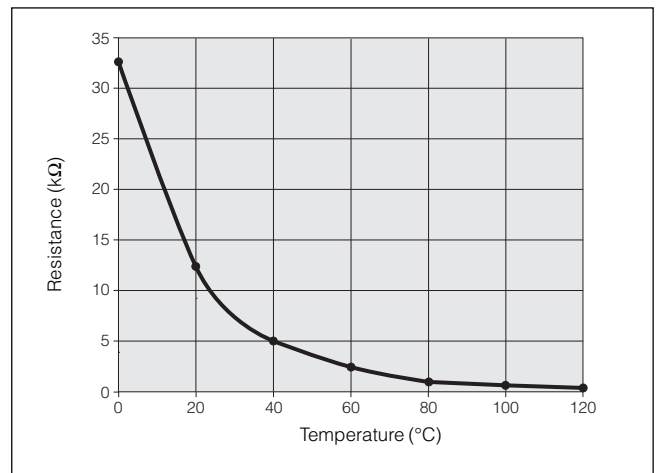

Diagram 1

#### Values table

Temp[°C]	0	10	20	30	40	50	60	70	80	90	100	110	120
R [kΩ]	32,54 ±2,2	19,87 ±1,0	12,48 ±0,5	8,06 ±0,4	5,33 ±0,3	3,60 ±0,25	2,48 ±0,17	1,75 ±0,13	1,25 ±0,1	0,91 ±0,08	0,67 ±0,06	0,50 ±0,05	0,38 ±0,04

### Repair step 3

#### Dismantle surface sensor

- Perform repair step 1, dismantle jacket cover.
  - Loosen the screws fastening the holding spring and remove the holding spring.
  - Pull the surface sensor out of the receptacle.
  - Unfasten and disconnect the 14-pin connector at the controller.
  - Using the unlocking tool, unclip the two cables from the surface sensor in the 14-chamber connector (chamber 7, cable 0.5<sup>2</sup> black and chamber 8, cable 0.5<sup>2</sup> black).
  - When fitting the surface sensor, wind both cables twice round the cable for the control and overheating sensor.
- Torque fastening screws holding spring: 3.3<sup>+0.3</sup> Nm

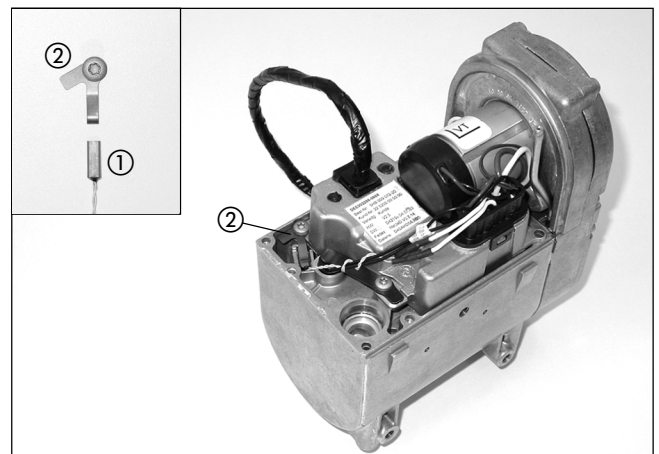

Fig. 3

- ① Surface sensor
- ② Holding spring

#### Bitte beachten

- Ensure that the cables are routed correctly (see fig. 2a)
- The surface heater with cable harness is one component and not available as individual parts if spares are required.

# 5 Repair instructions

## Check surface sensor

(Diagram 2)

Check the surface sensor with a digital multimeter. If the resistance value of the flame sensor is **outside** the table of values respectively diagram, then the flame sensor must be replaced.

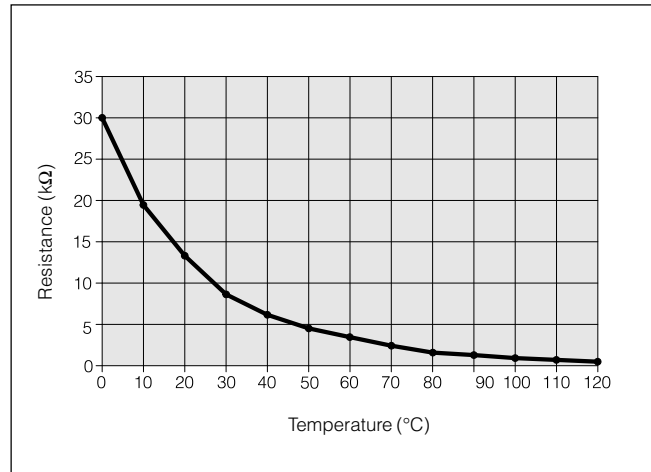

Diagram 2

## Values table

Temp[°C]	0	10	20	30	40	50	60	70	80	90	100	110	120
R [kΩ]	30,00	19,53	13,03	8,90	6,20	4,41	3,19	2,34	1,75	1,32	1,02	0,79	0,62
	±1,13	±1,6	±1,89	±2,2	±2,4	±2,9	±3,19	±3,6	±3,92	±4,4	±4,78	±5,3	±5,70

## Repair step 4

### Dismantle controller

- Perform repair step 1, dismantle jacket cover.
- Perform repair step 2, dismantle control and overheating sensor (here only the holding spring).
- Perform repair step 3, dismantle surface sensor.
- Unfasten and disconnect the 14-pole connector at the controller.
- Pull the bottom 4 fastening screws at the combustion chamber housing.
- Carefully pull the combustion chamber housing and combustion chamber with flame pipe out of the heat exchanger and put to one side.
- Remove the controller.  
Torque for the fastening screws: 6.5<sup>0.5</sup> Nm

#### Please note

- Before assembly replace the seals between combustion chamber and heat exchanger.
- Tighten the fastening screws cross-wise.

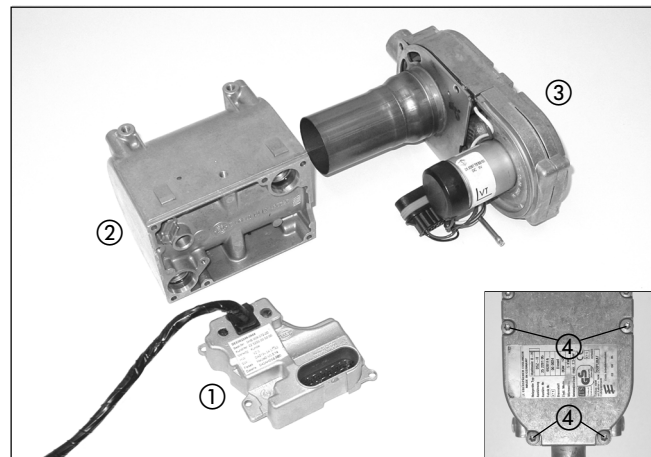

Fig. 4

- ① Controller
- ② Jacket
- ③ Combustion chamber housing
- ④ Fastening screws



## 5 Repair instructions

### Repair step 5

#### Remove glow plug

- Perform repair step 4, dismantle controller.
- Use the AMP unlocking tool to unclip the two glow plug cables in the 14-pin connector (chamber 3, cable 2<sup>2</sup> brown and chamber 6, cable 2<sup>2</sup> white).
- Separate combustion chamber with flame pipe from combustion chamber housing.
- Carefully pull the glow plug from the fitting in the combustion chamber.

Torque for the fastening screws: 6.5<sup>+0.5</sup> Nm

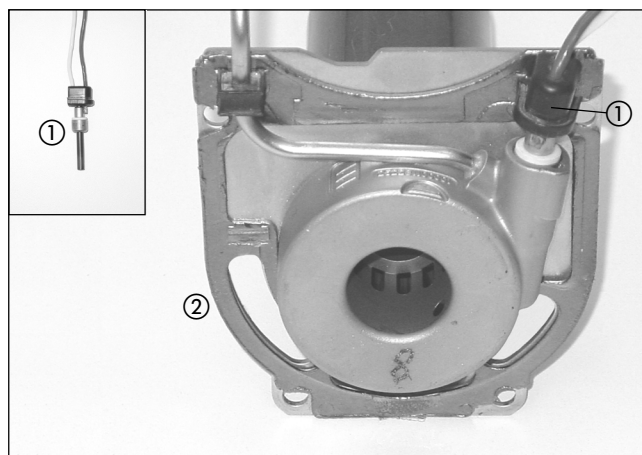

Fig. 5

- ① Glow plug
- ② Combustion chamber

#### Replace seals

- Remove both graphite seals ⑤ ⑥ between combustion chamber housing and combustion chamber, respectively between combustion chamber and heat exchanger.
- Remove the sealing residues and carefully clean the contact surfaces.
- Remove the white round insulation washer ④ in the combustion chamber housing.
- When fitting the semi-circular graphite seal ⑤ between combustion chamber housing and combustion chamber, lift the fuel pipe slightly so that the seal lies under the bush for the fuel pipe at the combustion chamber flange.
- Guide the round graphite seal ⑥ over the flame pipe and place it on the inside of the combustion chamber flange.
- Fit the white, round insulation washer in the receptacle in the combustion chamber housing.

Torque for the fastening screws: 6.5<sup>+0.5</sup> Nm

#### Please note

- When mounting the combustion chamber housing, ensure that the bush is in the right position.

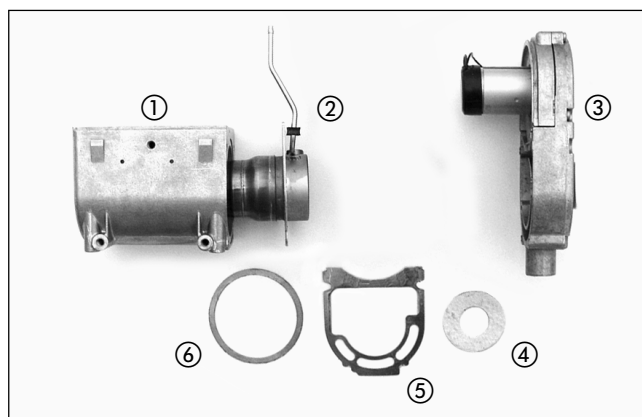

Fig. 6

- ① Jacket
- ② Combustion chamber
- ③ Combustion chamber housing
- ④ Insulating washer between bottom of combustion chamber and combustion chamber housing
- ⑤ Seal between combustion chamber flange and combustion chamber housing
- ⑥ Seal between combustion chamber and heat exchanger

Seal ⑤:  
Combustion chamber/combustion chamber housing  
Order number: 25 2281 01 00 10

Seal ⑥:  
Combustion chamber/heat exchanger  
Order number 25 2281 01 00 11

# 5 Repair instructions

## Repair step 6

### Remove flame sensor

- Perform repair step 4, dismantle controller.
- Use the AMP unlocking tool to unclip both cables from the flame sensor in the 14-pin connector (chamber 1, cable 0.25<sup>2</sup> brown and chamber 2, cable 0.25<sup>2</sup> brown).
- Pull the flame sensor up and out of the combustion chamber housing.
- Check the graphite bush at the flame sensor whether it can be used again (must not be pressed in), otherwise replace.
- For assembly, first place the graphite bush on the flame sensor.
- Insert the flame sensor in the housing groove (curve of the bush at the bottom).
- Replace the seals.  
Torque for the fastening screws: 6.5<sup>+0.5</sup> Nm

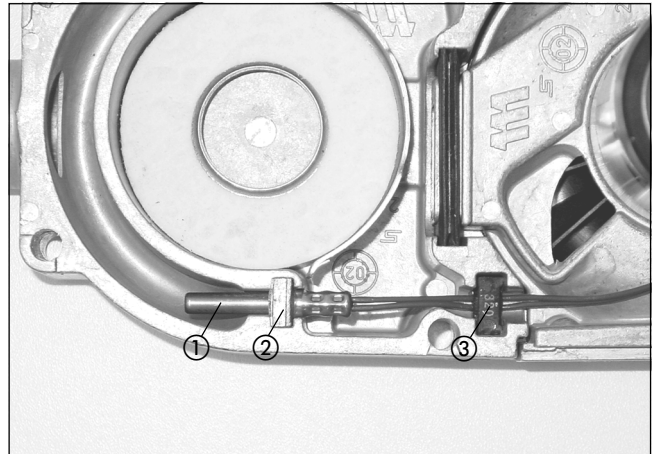
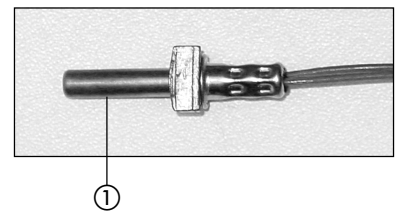

Fig. 7

- ① Flame sensor
- ② Graphite bush
- ③ Bush



### Check flame sensor

(Diagram 3)

Check the surface sensor with a digital multimeter. If the resistance value of the flame sensor is **outside** the table of values respectively diagram, then the flame sensor must be replaced.

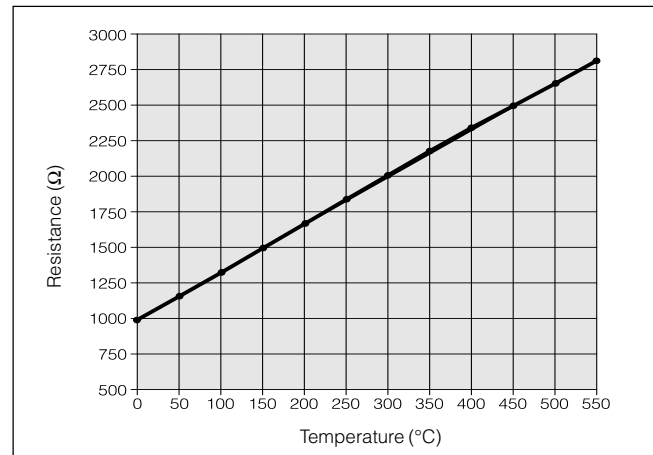

Diagram 3

### Values table

Temp[°C]	0	10	20	30	50	80	90	100	130	150	200	250	300	350	400
R [Ω]	1000	1022	1062	1097	1194	1309	1347	1385	1498	1573	1758	1941	2120	2297	2470
	±10	±10	±11	±11	±12	±13	±14	±15	±17	±20	±24	±28	±32	±36	±40

## 5 Repair instructions

### Repair step 7a

#### Dismantle combustion air fan

- Perform repair step 1, dismantle jacket cover.
- Disconnect 14-pin connector.
- Use the AMP unlocking tool to unclip the cable 0.75<sup>2</sup> brown from chamber 14 and the cable 0.75<sup>2</sup> black from chamber 13 in the 14-pin connector.
- Unscrew the 4 upper screws fastening the combustion chamber housing and remove the combustion air fan.
- Remove the O-ring and rectangular rubber seal.
- During assembly, insert the O-ring in the groove and fit the rectangular rubber seal on the support.

Torque of fastening screws

Combustion air fan: 2.4<sup>+0.3</sup> Nm

Torque of fastening screws Combustion chamber housing: 6.5<sup>+0.5</sup> Nm



#### Caution

Check connector is positioned correctly. Pay attention to right connection brown = chamber 14, black = chamber 13 because of the risk of reversing the poles.

#### Please note

Before assembly, carefully check the O-ring (item ②) between the combustion air fan and the combustion chamber, and replace if necessary.

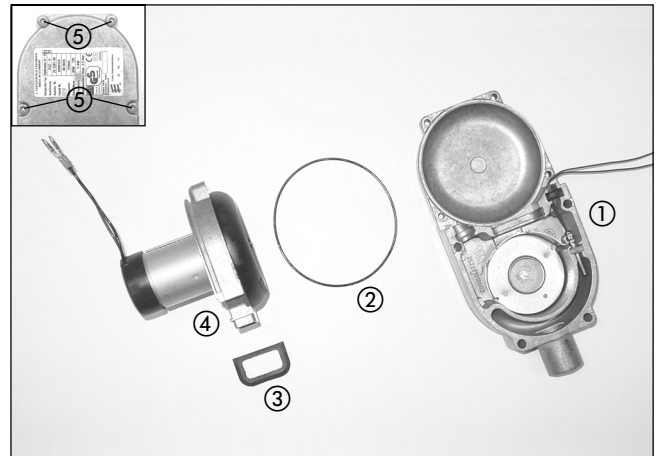

Fig. 8

- ① Combustion chamber
- ② O-ring
- ③ Rectangular rubber seal
- ④ Combustion air fan

### Repair step 7b

#### Measure the speed of the combustion air fan motor

- Measure speed of combustion air fan motor with max. 8.8 volt + 0.2 volt.
- Pay attention to the correct poles!
- Affix marking (white) to the fan wheel and measure the speed with a contact-free speed counter.
- If the speed is outside the range between 9500 rpm and 10500 rpm, then replace the combustion air fan.
- If the speed is within the range between 9500 rpm and 10500 rpm, then replace the controller.

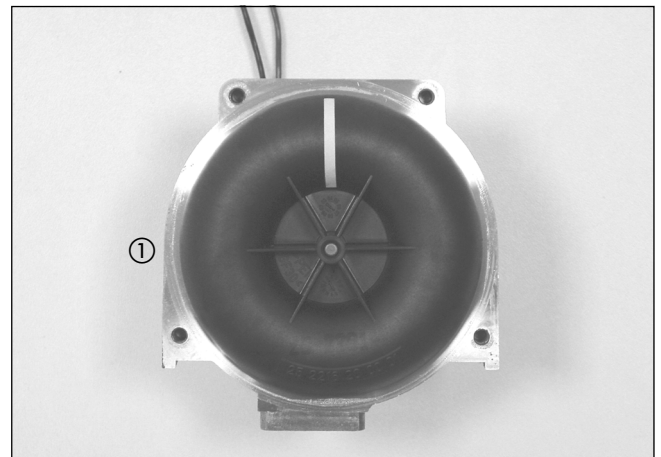

Fig. 9

- ① Combustion air fan

## 5 Repair instructions

### Repair step 8

#### Remove combustion chamber

- Perform repair step 4, dismantle controller.
- Perform repair step 5, remove glow plug
- Place the combustion air fan to one side.
- Take combustion chamber out of heat exchanger (heat exchanger does not have to be removed).

**Please note**

Before re-assembly, replace the seal between the heat exchanger and combustion chamber.

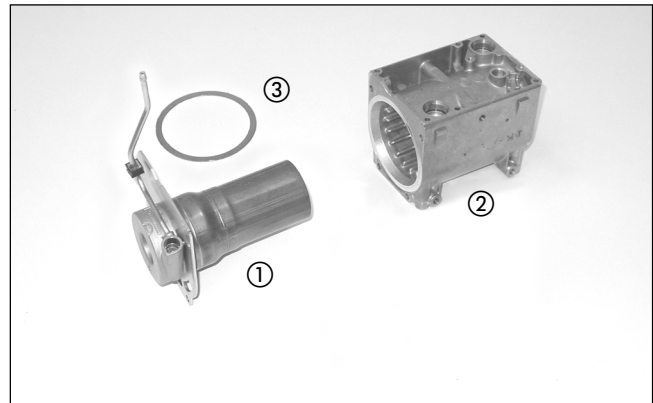

Fig. 10

- ① Combustion chamber
- ② Heat exchanger
- ③ Seal between combustion chamber and heat exchanger

### Repair step 9

#### Remove heat exchanger

- Perform repair step 8, Remove combustion chamber.
- Using a screwdriver, press the heat exchanger out of the jacket through the water inlet.
- Check the heat exchanger thoroughly, if necessary clean or replace.

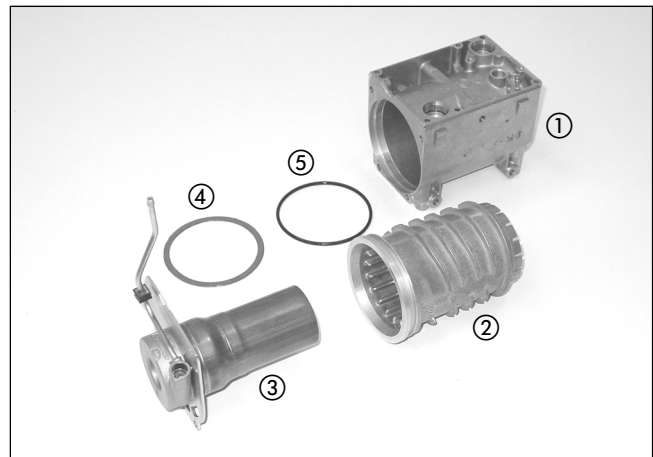

Fig. 11: HYDRONIC II-H

- ① Jacket
- ② Heat exchanger
- ③ Combustion chamber with flame tube
- ④ Seal – Combustion chamber / Heat exchanger
- ⑤ O-ring – Heat exchanger

## 5 Repair instructions

### Repair step 10

#### Re-mount heat exchanger

- Place the heat exchanger in the jacket: the groove in the bottom of the heat exchanger must fit in the stopper in the jacket bottom.  
As a guide, the socket for the overheating sensor must match the location hole in the jacket.

#### Please note

- Before assembly, carefully check the seals and O-ring and replace if necessary.
- Check that the heat exchanger fits properly in the jacket (the heater exchanger has to be pressed firmly into the jacket).
- Grease the O-ring with special grease (e.g. „Hellerine“) before fitting in position.

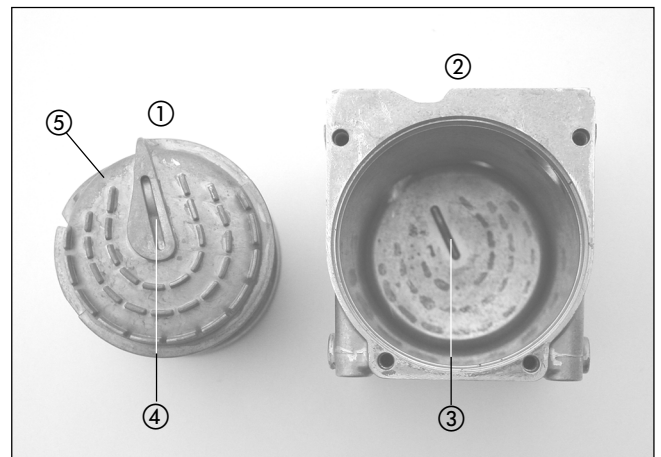

Fig. 12: HYDRONIC II-H

- ① Heat exchanger
- ② Jacket
- ③ Stopper
- ④ Groove in heat exchanger bottom
- ⑤ Base for the overheating sensor

### Measuring the fuel quantity

#### Preparing the measurement

- Pull the fuel pressure pipe from the heater and place it in a measuring beaker (10 cm<sup>3</sup>).
- Switch the heater on.  
After 20 sec. the dosing pump starts to pump fuel.  
If the fuel comes out in an even, bubble-free flow, then the fuel pipe is filled and vented.
- Switch the heater off and drain the beaker.

#### Measuring

- Switch the heater on.  
After 20 sec. the dosing pump starts to pump fuel.
- During measurement, hold the beaker on the same level as the heater.  
After another 90 sec., the fuel supply is automatically switched off.
- Switch the heater off as otherwise it will start up again.
- Read off the quantity of fuel in the beaker.

#### Evaluation

- Compare the measured fuel quantity with the values in the table shown below.  
If the measured fuel quantity is over the maximum value or under the minimum value, then the dosing pump has to be replaced.

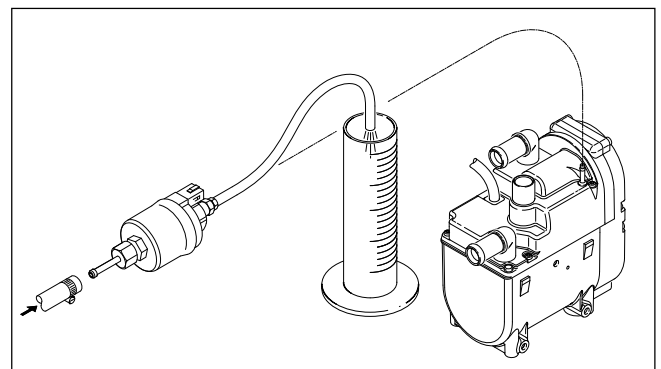

#### Fuel quantity

Nominal fuel quantity	12,0 cm <sup>3</sup> / 90 sec
Max. fuel quantity	12,7 cm <sup>3</sup> / 90 sec
Min. fuel quantity	11,3 cm <sup>3</sup> / 90 sec

#### Please note

Only measure the fuel flow when the battery is sufficiently charged.  
During the measurement, the controller should have min. 11 volt or max. 13 volt.

# 6 Wiring diagram

## Wiring diagram HYDRONIC II-H

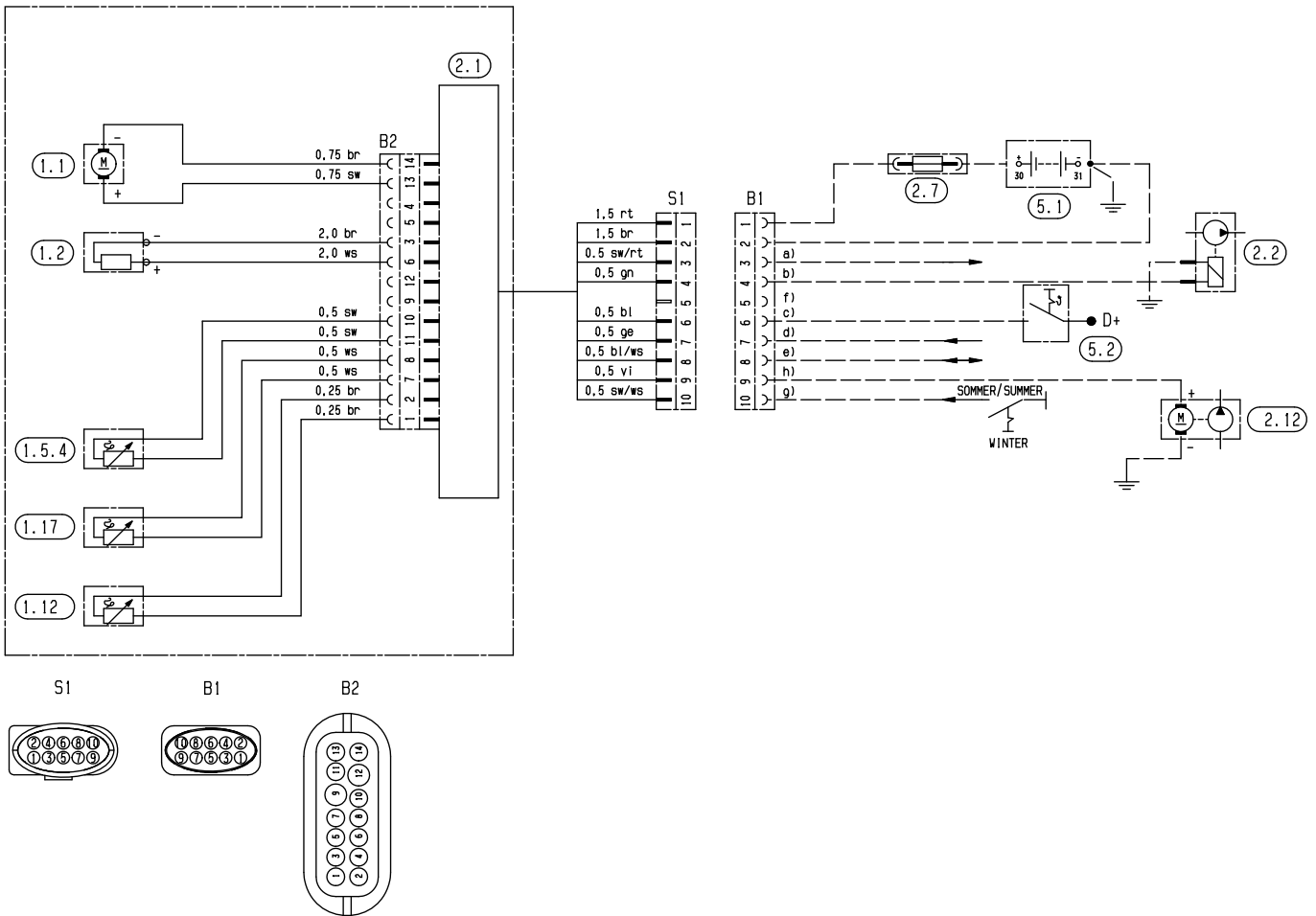



## 6 Wiring diagram

### Parts list

- 1.1 Heater motor
- 1.2 Glow plug
- 1.5.4 Controll and overheating sensor
  
- 1.12 Flame sensor
- 1.17 Surface sensor
  
- 2.1 Controller
- 2.2 Fuel dosing pump
- 2.7 Main fuse 20 A
- 2.12 Water pump
  
- 5.1 Battery
- 5.2 Temperature sensor (outside temperature)
  
- a) Relay, vehicle fan
- b) Dosing pump
- c) Auxiliary heating function
- d) Timer (optional)
- e) JE-diagnosis
- f) Free
- g) Fan preselection
- h) Water pump

### Cable colours

Length "plus" + length "minus":  
< 5 m: cross section 4 mm<sup>2</sup>  
> 5 m < 8 m: cross section 6 mm<sup>2</sup>



### Caution

*HYDRONIC.*

# 7 Service

---

## Certification

Guaranteed quality from Eberspächer

## Disposal

Disposal of materials

Dismantling the heater

Packaging

Quality management  
DIN EN ISO 9001:2000 and ISO/TS 16949:1999

Environment management  
DIN EN ISO 14001:1996

---



**Foreign representatives**

Argentinien  
Argentina  
Argentine

Estland  
Estonia  
Estonie

Iran  
Iran  
Iran

Finnland  
Finland  
Finlande

Japan  
Japan  
Japan

für Bootsheizungen  
for boat heaters /  
pour bateau chauffages

Frankreich  
France  
France

Kanada  
Canada  
Canada

Belgien u. Luxemburg  
Belgium and Luxembourg  
Belgique et Luxembourg

Griechenland  
Greece  
Grèce

Lettland  
Latvia  
Lettonie

Chile  
Chile  
Chili  
für Bootsheizungen  
for boat heaters /  
pour bateau chauffages

Großbritannien  
Great Britain  
Grande-Bretagne

Litauen  
Lithuania  
Lituanie

Dänemark  
Denmark  
Danemark

Italien  
Italy  
Italie

Republik Moldova  
Republic Moldavia  
République Moldavie

# 7 Service

---

## Foreign representatives

Niederlande  
Netherlands  
Pays-Bas

Schweden  
Sweden  
Suède

Ukraine  
Ukraine  
Ukraine

Norwegen  
Norway  
Norvège

Schweiz  
Switzerland  
Suisse

USA  
USA  
Etats-Unis

Österreich  
Austria  
Autriche

Spanien – Portugal  
Spain – Portugal  
Espagne – Portugal

Weißrussland  
Belarus  
Biélorussie

Polen  
Poland  
Pologne

Tschechien  
Czech Republic  
République Echèque

Russland  
Russia  
Russie

Türkei  
Turkey  
Turquie

Schweden  
Sweden  
Suède

Ungarn  
Hungary  
Hongrie

---



## List of abbreviations

ADR

ADR99

EU Type Permit

EMV

JE-partner

PME

## EU Declaration of Conformity

With regard to the following products

**heater type *HYDRONIC***

we herewith confirm that it conforms with the prime safety requirements stipulated in the directives of the EU Council for harmonisation of the legal regulations of the member states with regard to electromagnetic compatibility (89 / 336 / EEC).

This declaration applies to all heaters produced according to the production drawings *HYDRONIC* which are an integral part of this declaration.

The following standards/directives have been used to assess the product with regard to electromagnetic compatibility:

# 7 Service

---

## Keyword index

<u>Keyword</u>	<u>Page</u>	<u>Keyword</u>	<u>Page</u>
A		O	
		P	
C		Q	
		R	
D		S	
E			
F		T	
		W	
G			
H			
I			
J			
L			

---