

Water Heater



Thermo Top E Parking Heater

00 0003

Thermo Top C Parking Heater

00 0002

Installation documentation

Nissan Pathfinder and Navara

2.5l Diesel

from Model Year 2005

Manual / automatic air-conditioning

Passenger compartment monitoring

Manual / automatic transmission



WARNING!

Hazard warning:

Incorrect installation or repair of Webasto heating systems may cause a fire or result in the emission of carbon monoxide, which can be fatal. Serious or fatal injuries can be caused as a result.



Specialist company training, technical documentation, specialised tools and equipment are required to install and repair Webasto heating and cooling systems. Only original Webasto parts must be used. For this, also see the catalog of air and water heater accessories from Webasto.

NEVER attempt to install or repair Webasto heating or cooling systems if you have not successfully completed the company training and thereby acquired the required technical skills, or if you do not have access to the required technical documentation, tools and equipment needed to carry out correct installation and repairs.

ALWAYS follow all Webasto installation and repair instructions and observe all warnings.

The initial startup is to be executed with the Webasto Thermo Test Diagnosis.

Webasto does not accept any liability for defects and damage that are attributable to installation by untrained staff.

Nissan Pathfinder and Navara

Table of Contents

Validity	2	Preparing installation location	18
Heater/Installation Kit	3	Premounting heater	19
Foreword	3	Installing Heater	21
General Instructions	3	Coolant circuit, manual transmission and	
Special Tools	3	140 kW automatic transmission	22
Explanatory Notes on Document	4	Coolant circuit 126 and 128 kW	
Preliminary Work	5	Automatic transmission	27
Heater installation location	5	Combustion air	30
Preparing electrical system	6	Fuel	31
Electrical system	7	Exhaust gas	34
Remote option (Telestart)	8	Final Work	37
Fan control for manual air conditioning	9	Operating Instructions for End Customer	39
Automatic air-conditioning fan control	11		
Up to MY 2010	11		
From MY 2011 without navigation system	12		
From MY 2011 with navigation system	13		
Additionally with passenger compartment monitoring	16		

Validity

Manufacturer	Model	Type	EG-BE No./ABE
Nissan	Pathfinder	R51	e9 * 2001/116 * 0051 * ...
Nissan	Pathfinder	R51	K492
Nissan	Navara	D40	L617

Engine type	Engine model	Output in kW	Displacement in cm ³
YD25	Diesel	128	2488
YD25	Diesel/DPF	126	2488
YD25	Diesel/DPF	140	2488

Vehicle and engine types, equipment variants and national specifications not listed in this installation documentation have not been tested. However, installation according to this installation documentation may be possible.

The installation location of a digital timer and summer/winter switch should be confirmed with the end customer before installation.

Nissan Pathfinder and Navara

Heater/Installation Kit

Quantity	Description	Order No.:
1	Heater / delivery scope	See Nissan price list
1	Installation Kit for Nissan Pathfinder 2.5l Diesel	1303633D
1	Heater control	See Nissan price list

Heater recommended for the respective vehicle class:

Vehicle	Heater
Compact car	Thermo Top E
Mid-size car, station wagon	Thermo Top C

The selection of the heater is based on the passenger compartment size of the vehicle and the level of comfort required by the customer.



Foreword

The installation documentation applies to the Nissan Pathfinder and Navara vehicles with a 2.5l Diesel engine - For the validity, see page 2 - from model year 2005 and later, assuming technical modifications to the vehicle do not affect installation, any liability claims excluded. Depending on the vehicle version and equipment, modifications may be necessary during installation with respect to this installation documentation.

However, the stipulations in this "installation documentation", the "operating instructions and "Installation instructions" for the *Thermo Top C/E* should be observed under all circumstances.

The corresponding rules of technology and any information from the vehicle manufacturer should be observed during the installation work.

General Instructions

Installation should be carried out according to the general, standard rules of technology. Unless specified otherwise, fasten hoses, lines and wiring harnesses to original vehicle lines and wiring harnesses using cable ties.

Sharp edges should be fitted with rub protection (cut-open plastic hose).

Spray unfinished body areas, e.g. drilled holes, with anti-corrosion wax (Tectyl 100K, Order No. 111329).

When installing an IPCU, check or adjust the corresponding settings before installation.

Special Tools

- Torque wrench for 2.0 - 10 Nm
- Hose clamping pliers

Explanatory Notes on Document

To provide you with a quick overview of the individual working steps, you will find an identification mark on the outside top right corner of the page in question.

Mechanical system

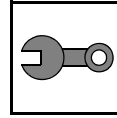

Electrical system

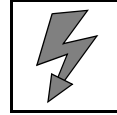

Coolant circuit

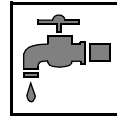

Fuel

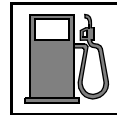

Exhaust gas

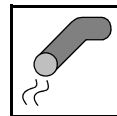

Combustion air

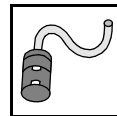

Special features are highlighted using the following symbols:



Specific risk of injury or fatal accidents.



Specific risk of damage to components.



Specific risk of fire or explosion.



Reference to general installation instructions of Webasto components or to the manufacturer's vehicle-specific documents.



Reference to a special technical feature.

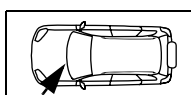
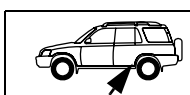

The arrow in the vehicle icon indicates the position on the vehicle and the viewing angle.

Preliminary Work

WARNING!

- Copy the factory number from the original type label to the duplicate type label.
- Remove years that do not apply from the duplicate label.
- Attach the duplicate label (type label) in the appropriate place.
- Open fuel tank cap, ventilate tank.
- Close the fuel tank cap again.
- Disconnect and remove the battery.
- Depressurize the cooling system.
- Remove the engine cover.
- Remove the intake hose between the intercooler and the engine.
- Detach the fuel filter.
- Remove the right front wheel.
- Remove the right-hand wheel well trim.
- Remove the underride protection.
- Remove the lower footwell trim on the front passenger side (with manual air conditioning).
- Remove the A-pillar trim on the front passenger side (only with passenger compartment monitoring)
- Remove front interior lighting and monitoring sensors (only with passenger compartment monitoring)
- Uncover A/C control unit / A/C booster
- Remove the glove compartment (with manual air conditioning).
- Remove the lower instrument panel trim on the driver's side
- Remove the drink holder between the front seats
- Remove the trim of the shift lever
- Remove the trim of the centre console, one M6 bolt each laterally [audio unit]
- Remove display navigation system, if it exists
- Remove A/C control panel (4 bolts), A/C control unit or A/C booster according to manufacturer's instructions

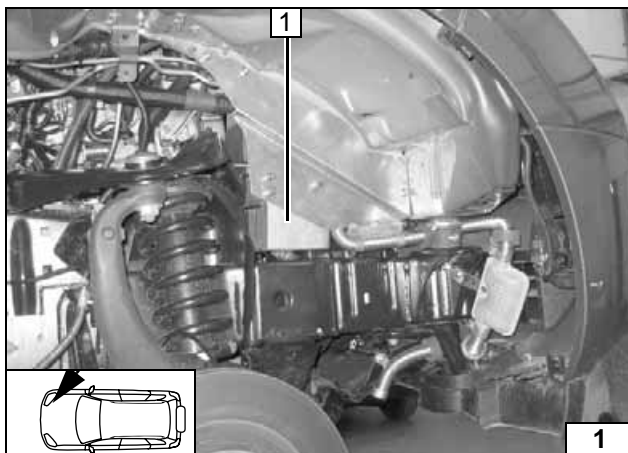

Heater installation location

1 Heater

Installation location

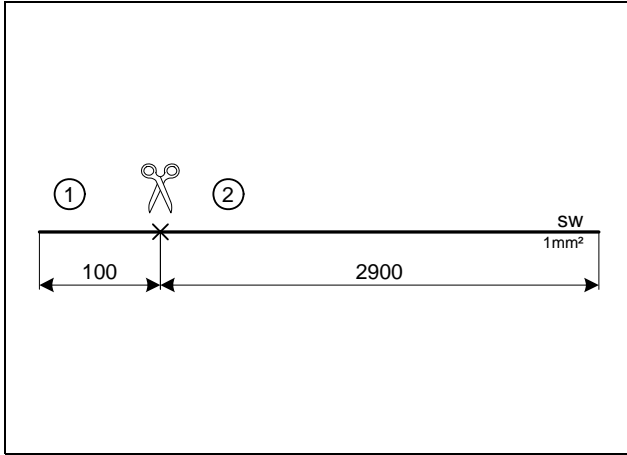

Preparing electrical system

All equipment

Cutting wire to length

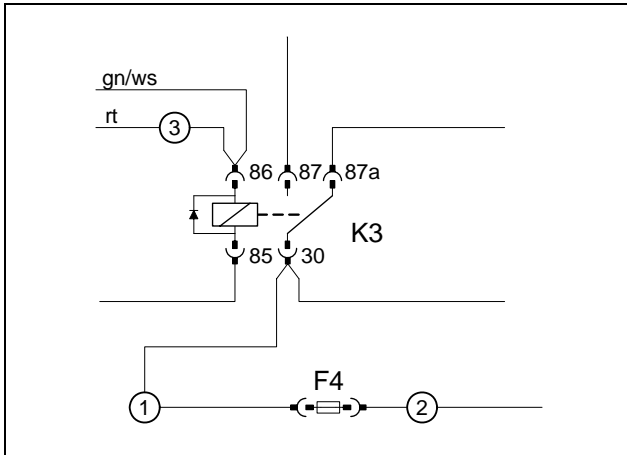

Produce connections as shown in wiring diagram.

Cut included protective sleeving to length of 2500 mm and push onto wire (2).



Only with passenger compartment monitoring

Also connect 3000 mm long red (rt) wire (3) to K3/86 and pull into protective sleeving.

Connecting fuse F4

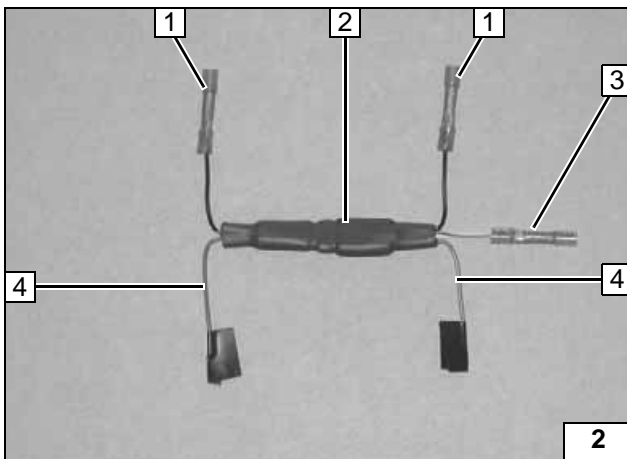

Only with automatic air-conditioning

Cut off tab connector at position 3 and crimp on connector.

- (1) Connector [2x]
- (2) Diode group
- (4) Insulate blue (bl) wire [2x] and tie back



Preparing diode group

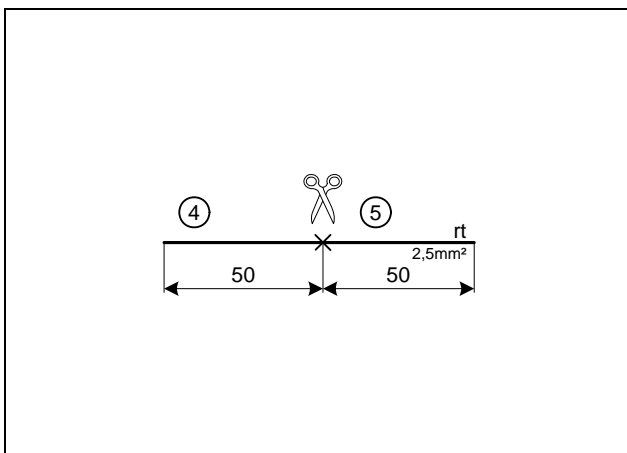

Wire sections (4) and (5) will be used later.



Cutting wire to length



Electrical system

Fuse holder, K3 relay

WARNING:
Do not damage tank

(1) 6.5 mm dia. hole

Fuse holder, K3 relay

- (1) Positive wire on positive support point
- (2) K3 relay, M5x12 bolt, large diameter washer, flanged nut
- (3) M6x12 bolt, angle bracket, flanged nut
- (4) Retaining plate, M5x12 bolt, large diameter washer, flanged nut
- (5) Fuse holder mounted
- (6) Earth wire on negative battery terminal

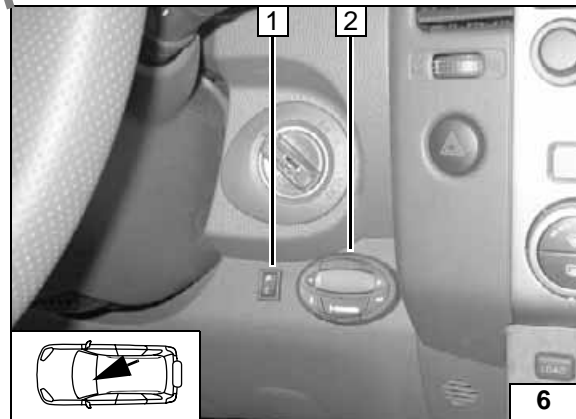
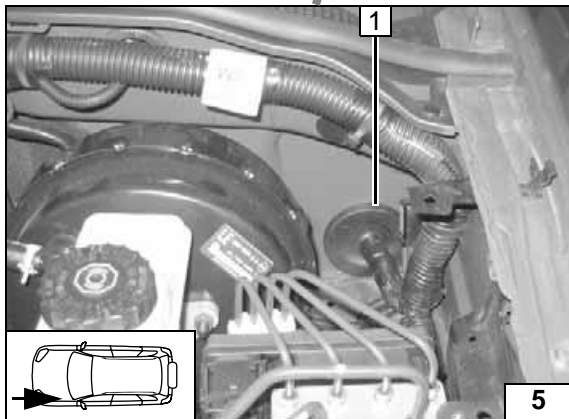
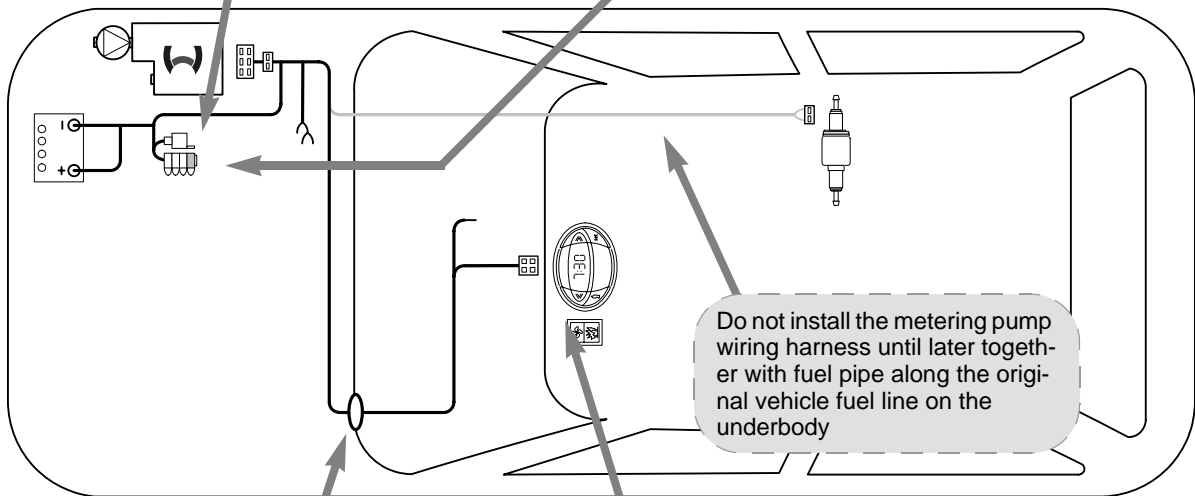
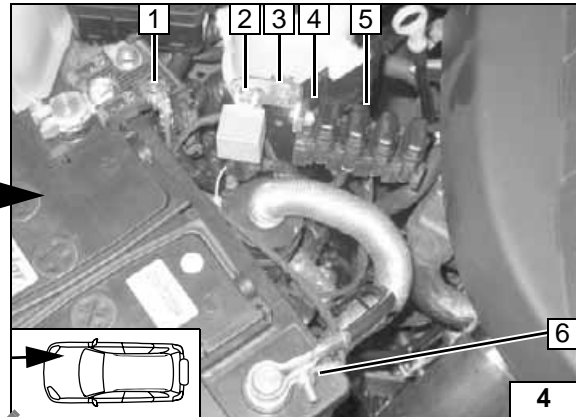
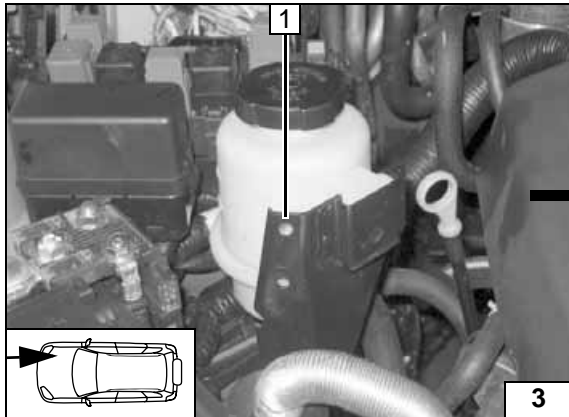

Wiring harness pass through

(1) Protective rubber plug

Digital timer, summer/winter switch option

- (1) Summer/winter switch, 12 mm dia. hole
- (2) Digital timer with extension wiring harness, drilling template



Wiring harness routing installation diagram

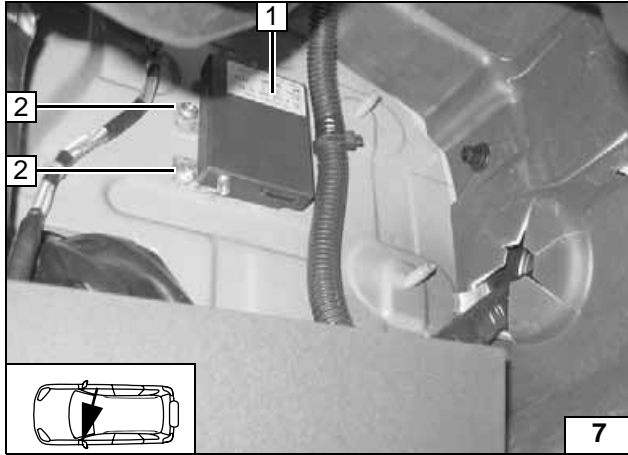

Remote option (Telestart)

- (1) Receiver
- (2) 4 mm dia. hole; 5.5x13 self-tapping screw [2x]



Installing receiver

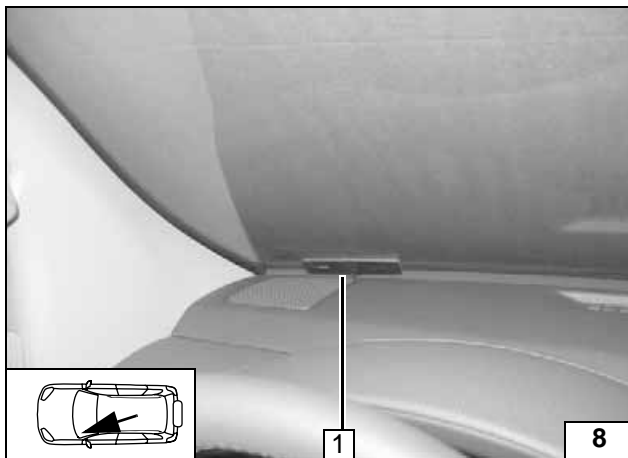

Produce all connections in accordance with general installation instructions provided and fasten wires with cable ties.

- (1) Antenna



Installing antenna

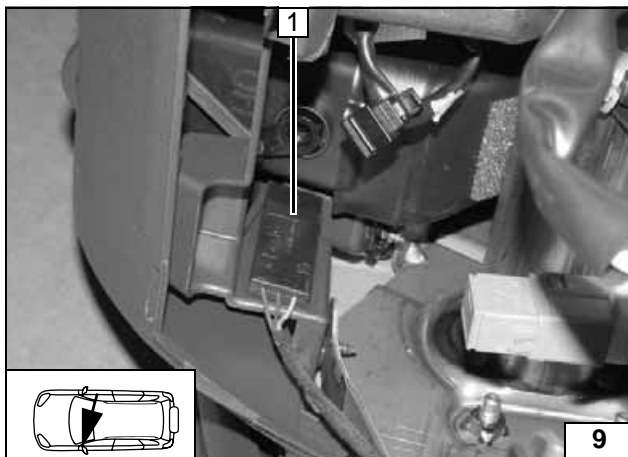

Temperature sensor T100 HTM

Fasten temperature sensor (1) with adhesive tape.



Installing temperature sensor



Fan control for manual air conditioning

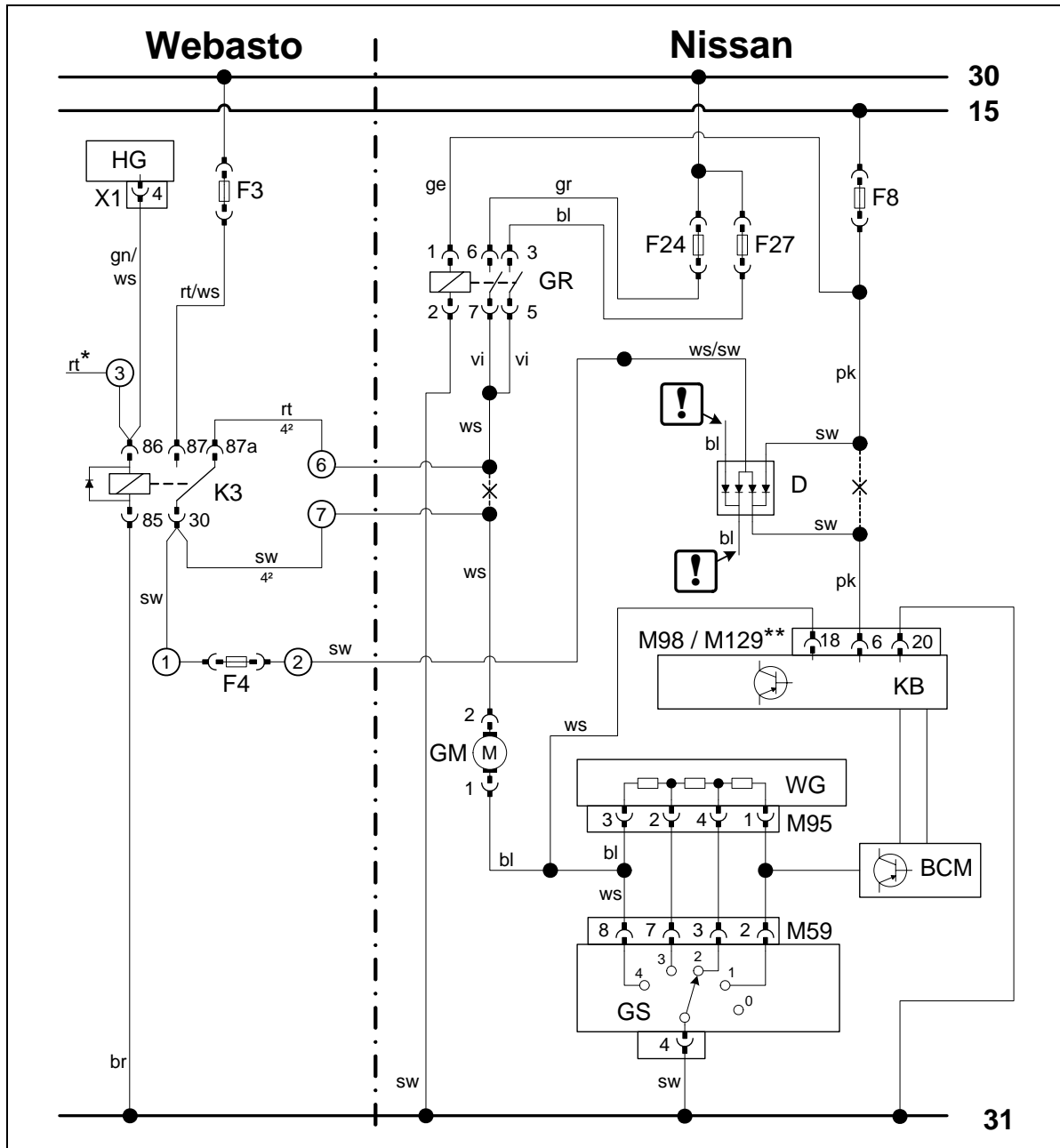

Wiring diagram

Webasto components		Nissan components		Colours and symbols	
HG	Heater	GM	Fan motor	rt	red
X1	6-pin heater connector	GR	Fan relay	ws	white
F3	25 A fuse	WG	Resistor group	sw	black
K3	Fan relay	M95	4-pin connector WG	br	brown
F4	3A fuse	GS	Fan switch	gn	green
D	Diode group	M59	8-pin connector GS	bl	blue
*	Red (rt) wire ③ only in vehicle with passenger compartment monitoring	F24	15A fuse	gr	gray
**	From MY 2011	F27	15A fuse	vi	violet
		F8	10A fuse	pk	pink
		KB	A/C control panel	!	Insulate wire ends and tie back
		M98	26-pin connector KB up to MY 2010	X	Cutting point
		M129	26-pin connector KB up to MY 2011		Wiring colours may vary.

Legend

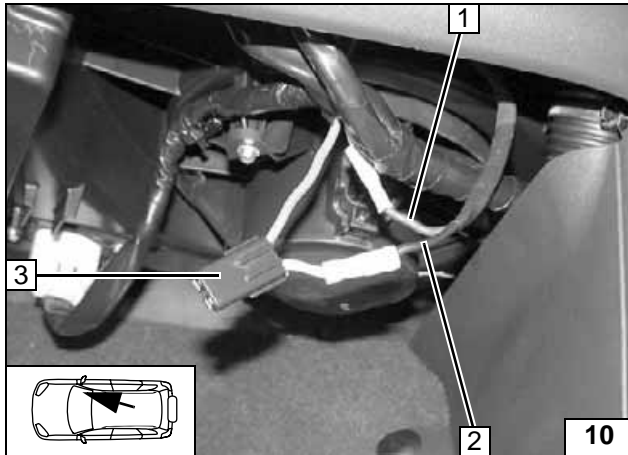

Connection to 2-pin connector from fan motor. Cut off approx. 50 mm white (ws) wire before connector. Produce connections as shown in wiring diagram.

- (1) Red (rt) wire ⑥ from K3/87a
- (2) Black (sw) wire ⑦ from K3/30
- (3) 2-pin connector of fan motor, disconnected



Connecting fan-motor

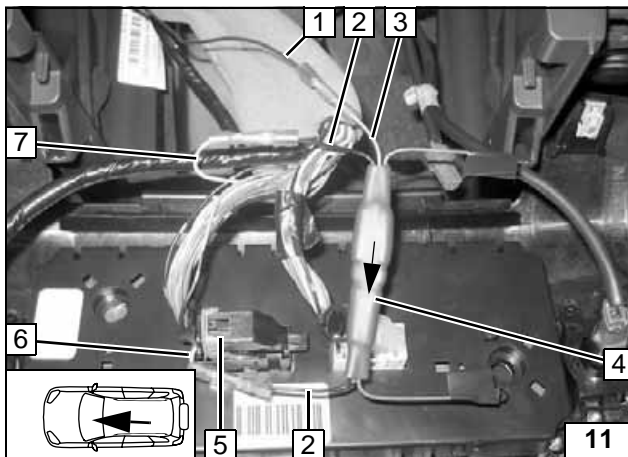

Connection on 26-pin connector (5) from A/C control unit (for connector, see following figure). Pay attention to the flow direction of the diode group (4). Insulate and tie back blue (bl) wire [2x] of diode group (4). Produce connections as shown in wiring diagram.

- (1) Black (sw) wire ② from fuse F4
- (2) Black (sw) wire to diode group [2x]
- (3) White/black (ws/sw) wire to diode group
- (6) Pink (pk) wire to 26-pin connector Pin 6
- (7) Pink (pk) wire from F8 fuse



Connection to A/C control unit

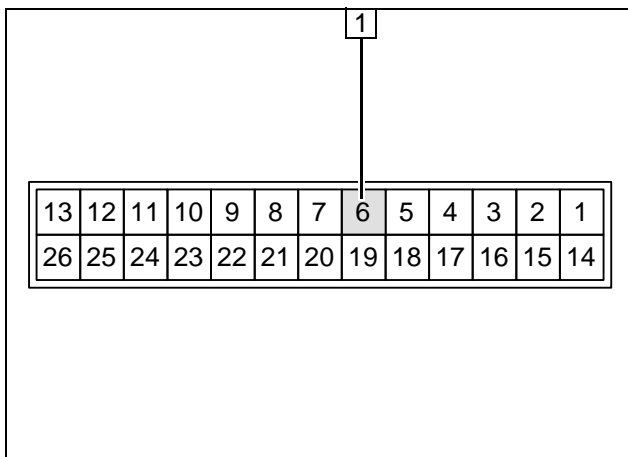

M98 connector up to MY 2010
M129 connector from MY 2011

- (1) 26-pin wire-side connector, Pin 6

26-pin connector KB



Automatic air-conditioning fan control

Up to MY 2010

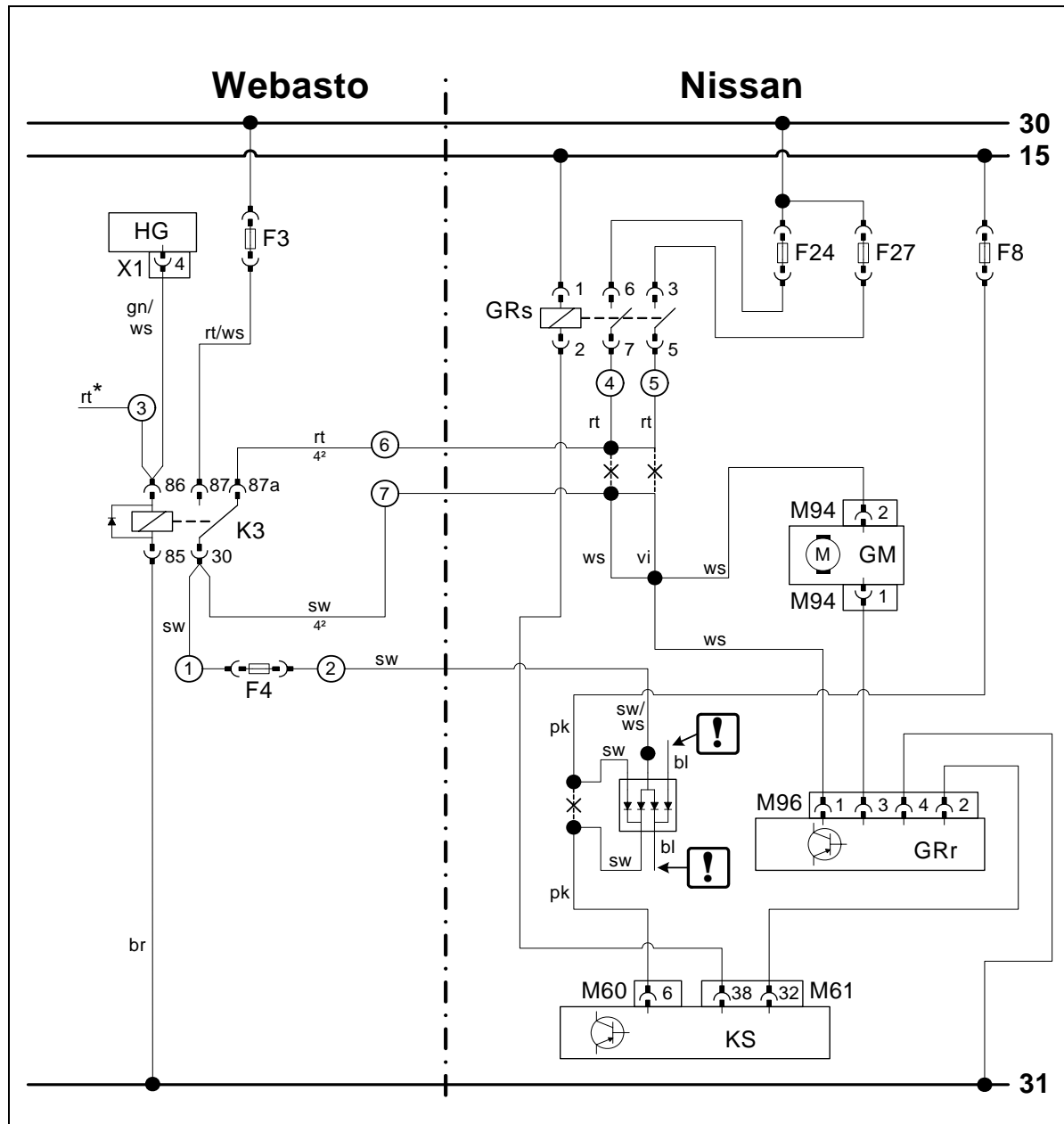

Wiring diagram

Webasto components		Nissan components		Colours and symbols	
HG	Heater	F24	15A fuse	rt	red
X1	6-pin heater connector	F27	15A fuse	ws	white
F3	25 A fuse	F8	10A fuse	sw	black
F4	3A fuse	GRs	Fan relay, front	br	brown
K3	Fan relay	GM	Fan motor, front	gn	green
D	Diode group	M94	2-pin connector GM	pk	pink
*	Red (rt) wire ③ only in vehicle with passenger compartment monitoring	KS	A/C control unit	vi	violet
		M60	26-pin connector KS	!	Insulate wire ends and tie back
		GRr	Fan controller, front	X	Cutting point
		M96	Connector GRr		Wiring colours may vary.

Legend

Nissan Pathfinder and Navara



From MY 2011 without navigation system

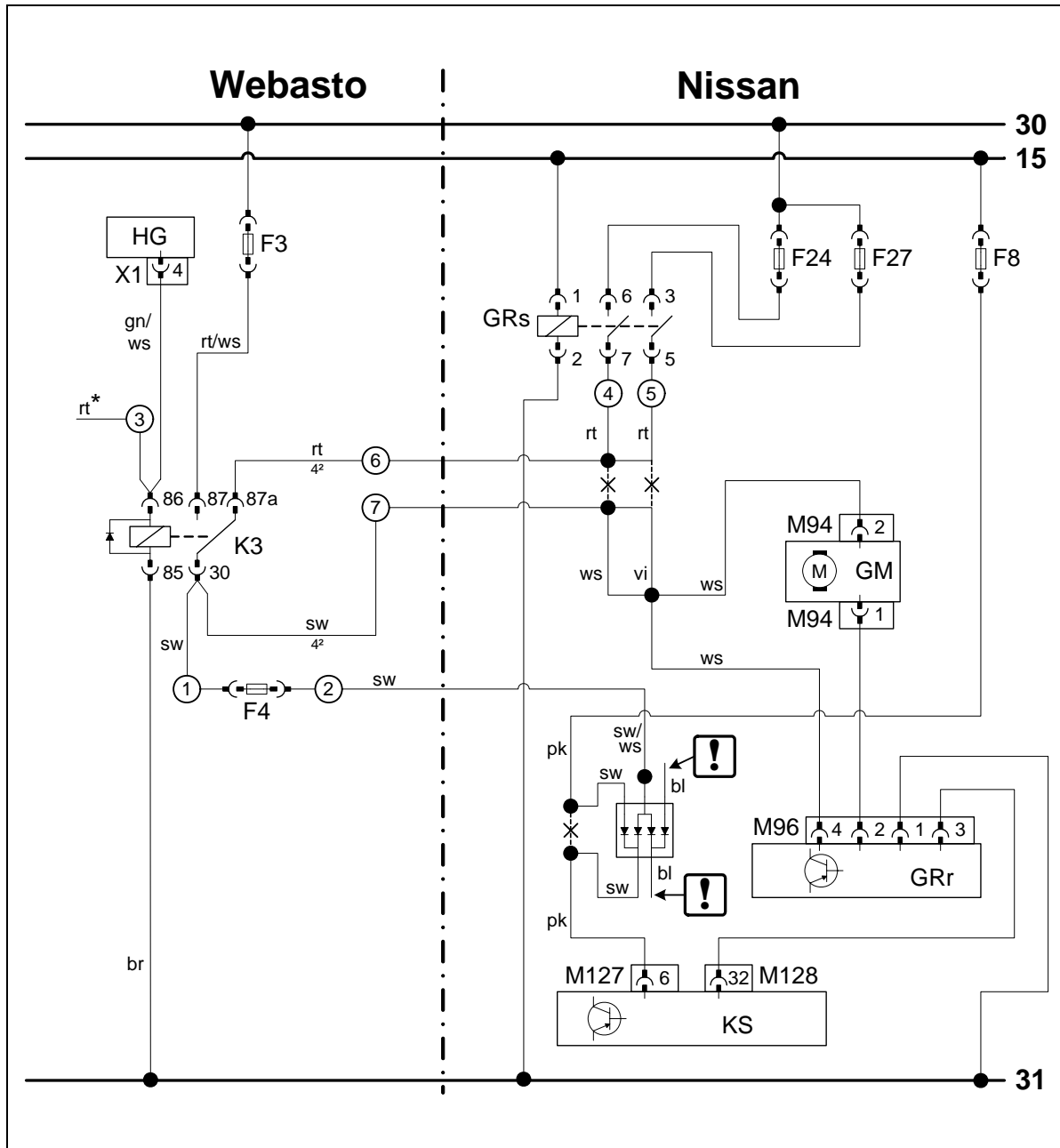

Wiring diagram

Webasto components		Nissan components		Colours and symbols	
HG	Heater	F24	15A fuse	rt	red
X1	6-pin heater connector	F27	15A fuse	ws	white
F3	25 A fuse	F8	10A fuse	sw	black
F4	3A fuse	GRs	Fan relay, front	br	brown
K3	Fan relay	GM	Fan motor, front	gn	green
D	Diode group	M94	2-pin connector GM	pk	pink
		KS	A/C control unit	vi	violet
*	Red (rt) wire ③ only in vehicle with passenger compartment monitoring	M127	26-pin connector KS		
		GRr	Fan controller, front		
		M96	Connector GRr		
				!	Insulate wire ends and tie back
				X	Cutting point
					Wiring colours may vary.

Legend

Nissan Pathfinder and Navara



From MY 2011 with navigation system

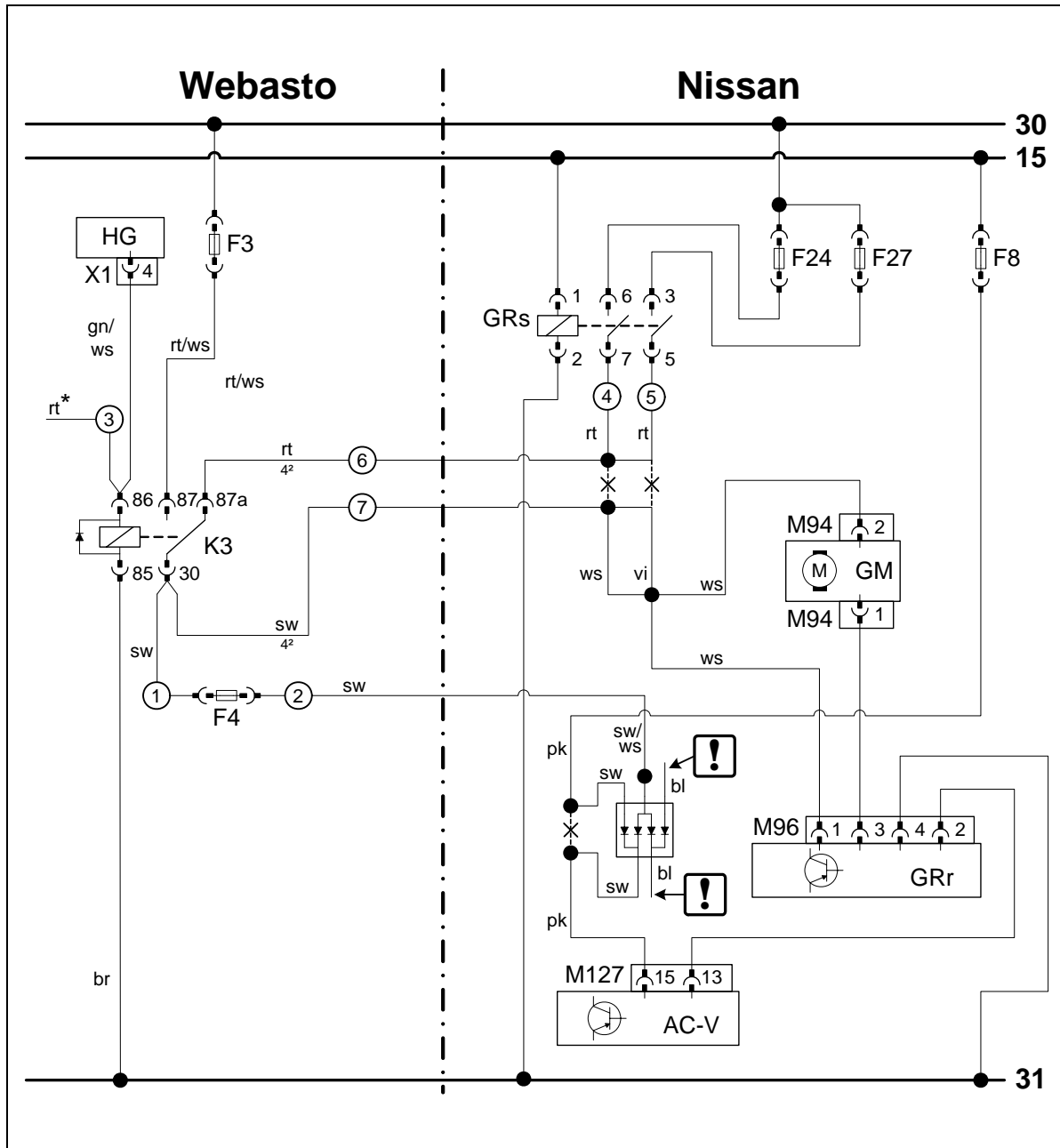

Wiring diagram

Webasto components		Nissan components		Colours and symbols	
HG	Heater	F24	15A fuse	rt	red
X1	6-pin heater connector	F27	15A fuse	ws	white
F3	25 A fuse	F8	10A fuse	sw	black
F4	3A fuse	GRs	Fan relay, front	br	brown
K3	Fan relay	GM	Fan motor, front	gn	green
D	Diode group	M94	2-pin connector GM	pk	pink
		AC-V	AC booster	vi	violet
*	Red (rt) wire ③ only in vehicle with passenger compartment monitoring	M127	26-pin AC-V connector		
		GRr	Fan controller, front		
		M96	4-pin connector, GRr		
				!	Insulate wire ends and tie back
				X	Cutting point
					Wiring colours may vary.

Legend

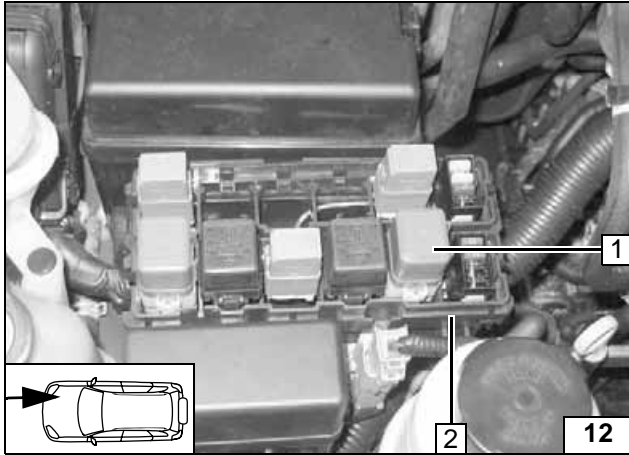

All automatic air-conditioning equipment

Fan motor is connected on original vehicle fan relay front (1) in engine compartment.

(2) Relay carrier

Seen from above. Imprint on relay or socket may differ from original vehicle wiring diagram, and is therefore irrelevant.

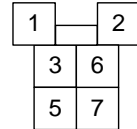

Fan relay

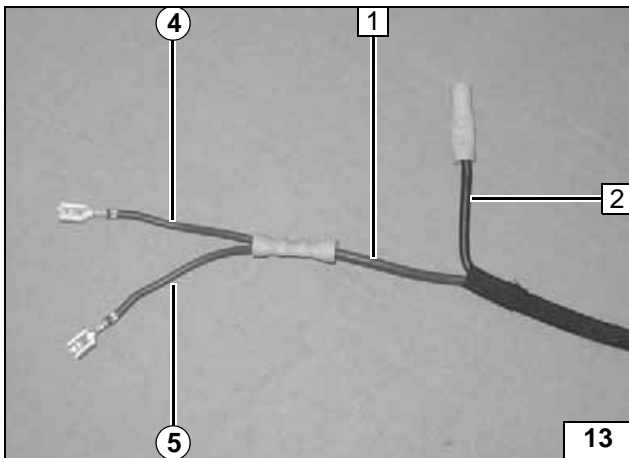

Route wiring harness from K3 relay to relay carrier and cut to length. Premount wiring harness with included yellow (ge) connector and tab receptacles as shown in figure and wiring diagram. Connect prepared wire sections ④ and ⑤.

- (1) Red (rt) wire ⑥ from K3/87a
- (2) Black (sw) wire ⑦ from K3/30



Preparing wiring harness

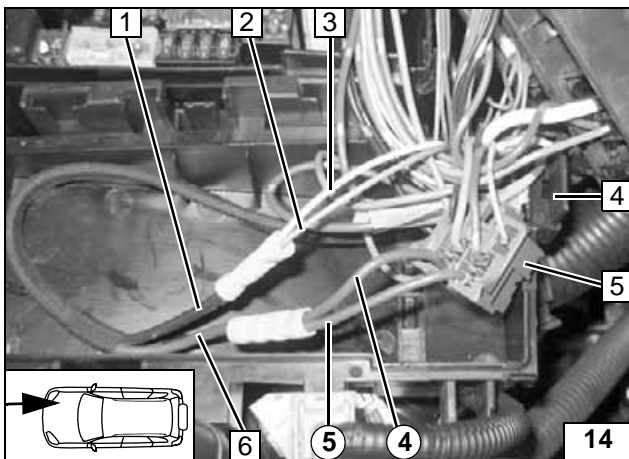

Expose relay carrier as shown. Uncrimp original vehicle violet (vi) (2) and white (ws) (3) wires from relay socket (5), Pin 5 and 7, and cut off tab receptacles. Produce connections as shown in wiring diagram.

- (1) Black (sw) wire ⑦ from K3/30
- (2) Violet (vi) wire to fan motor and fan controller
- (3) White (ws) wire to fan motor and fan controller
- (4) Relay carrier
- (5) Relay socket
- (6) Red (rt) wire ⑥ from K3/87a



Connecting fan motor

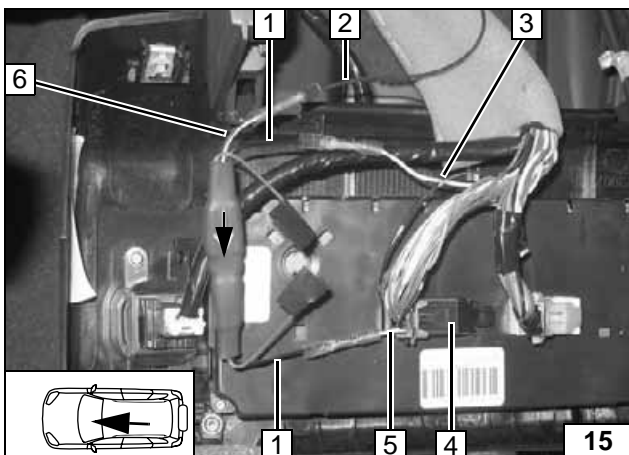

Up to MY 2010 and from MY 2011 without navigation system

Connection to 26-pin M60 / M127 connector (4) Pin 6 (for connector, see following figure). Produce connections as shown in wiring diagram.

- (1) Black (sw) wire to diode group [2x]
- (2) Black (sw) wire ② from fuse F4
- (3) Pink (pk) wire from F8 fuse
- (5) Pink (pk) wire to 26-pin connector Pin 6
- (6) White/black (ws/sw) wire to diode group



Connection to A/C control unit

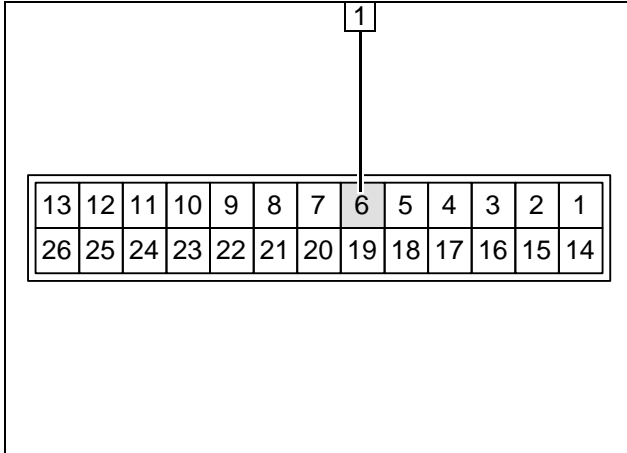

M60 connector up to MY 2010
M127 connector from MY 2011

(1) 26-pin wire-side connector, Pin 6



26-pin connector of A/C control unit

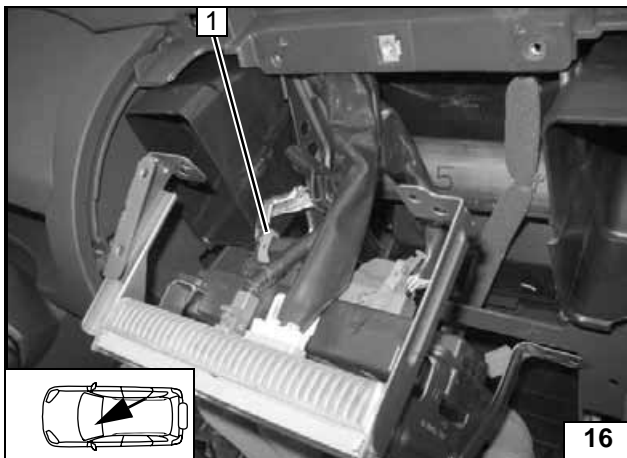

From MY 2011 with navigation system

Pull out M127 connector (1) from A/C booster [behind screen].



Connecting A/C booster.

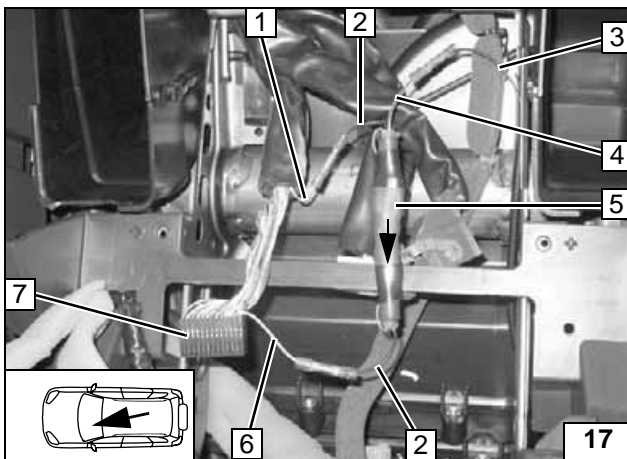

Connection on 26-pin M127 connector 7 Pin 15 from A/C booster. Pay attention to the flow direction of the diode group 5. Insulate and tie back blue (bl) wire [2x] of diode group 5 as shown. Produce connections as shown in wiring diagram.

- (1) Pink (pk) wire from F8 fuse
- (2) Black (sw) wire to diode group [2x]
- (3) Black (sw) wire ② from fuse F4
- (4) White/black (ws/sw) wire to diode group
- (6) Pink (pk) wire of connector M127, Pin 15



Controller of A/C control unit

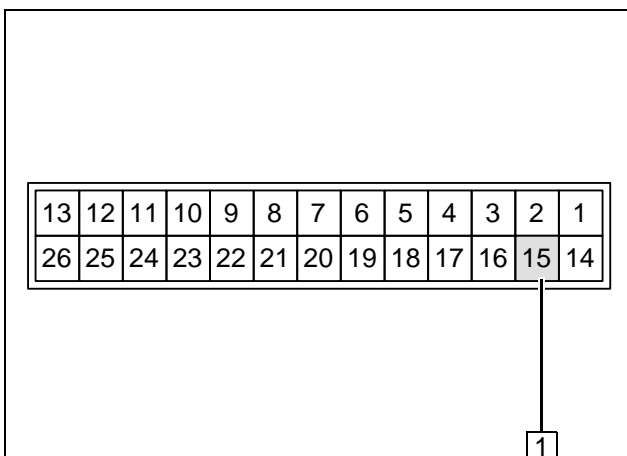

1 M127 connector on wire-side, Pin 15

26-pin connector of A/C control unit

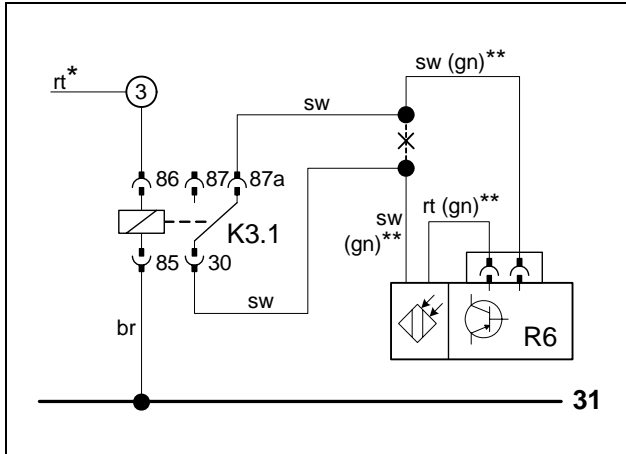

Additionally with passenger compartment monitoring

Webasto components:

K3.1= Additional relay
rt* = Red (rt) wire ③ from K3/86

Vehicle components:

R6 = Ultrasound sensor
** = black (sw) or red (rd) up to MY 2010, green (gn) from MY 2011

Legends:

X = Cutting point
rt = Additional red (rt) wire
sw = Additional black (sw) wire
br = Additional brown (br) wire



Wiring diagram for passenger compartment monitoring

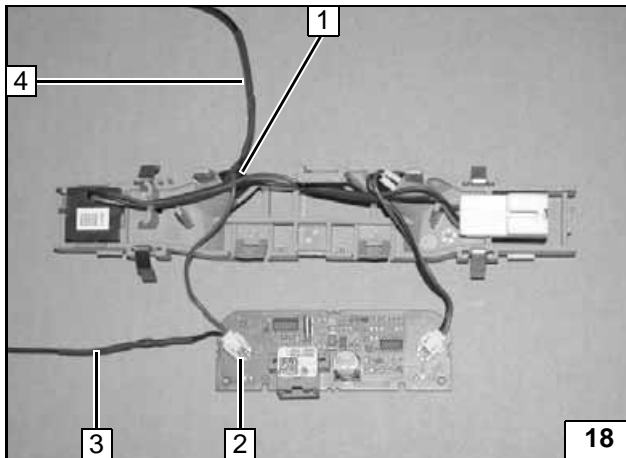

Up to MY 2010

Connection on 2-pin connector (2) of ultrasonic sensor control unit. Disconnect black (sw) wire from 2-pin connector (2) and connect to attached black (sw) wires (3) and (4) (solder and insulate). Pull black (sw) wires (3) and (4) into protective sleeving.

(1) Ultrasonic sensor R6



Disconnecting and extending wire

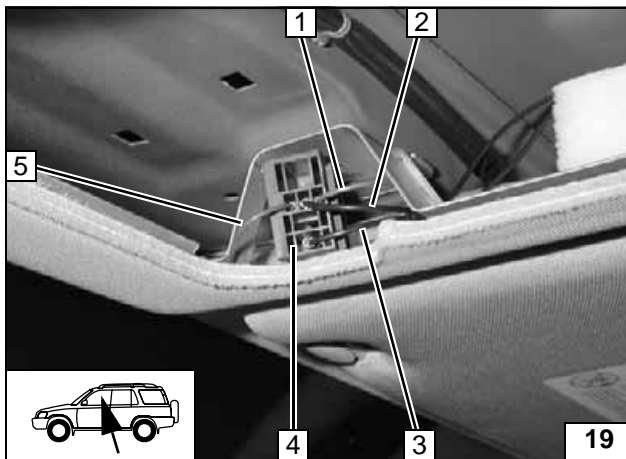

(1) Additional brown (br) wire K3.1/85
(2) Black (sw) wire from ultrasound sensor R6
(3) Black (sw) wire from ultrasound sensor R6
(4) K3.1 relay
(5) Red (rt) wire ③ from K3/86

Preparing K3.1 relay

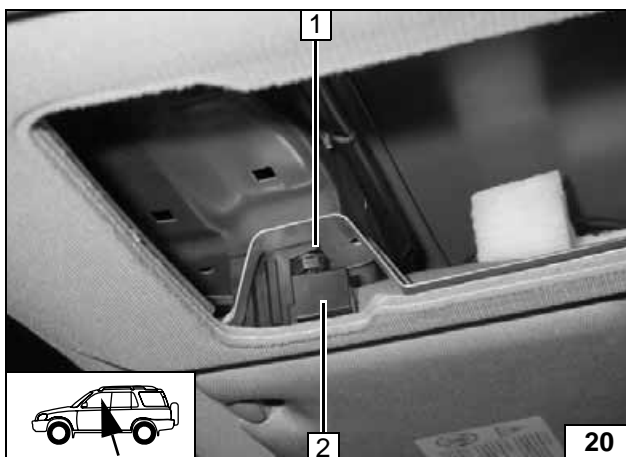

(1) Original vehicle bolt
(2) K3.1 relay

Installing K3.1 relay

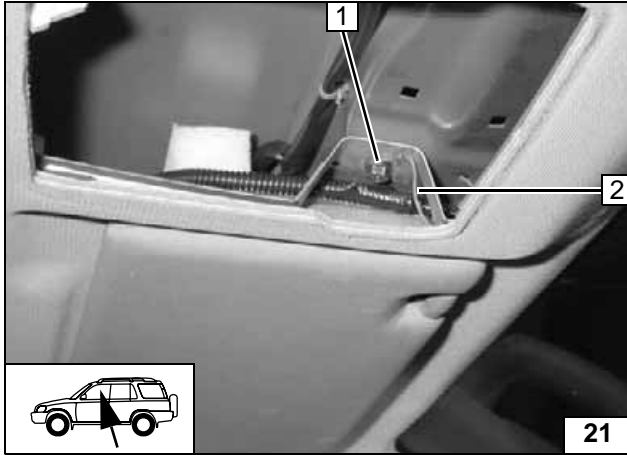

- (1) Original vehicle bolt
- (2) Extra brown (br) wire K3.1/85

Earth connection
K3.1 relay

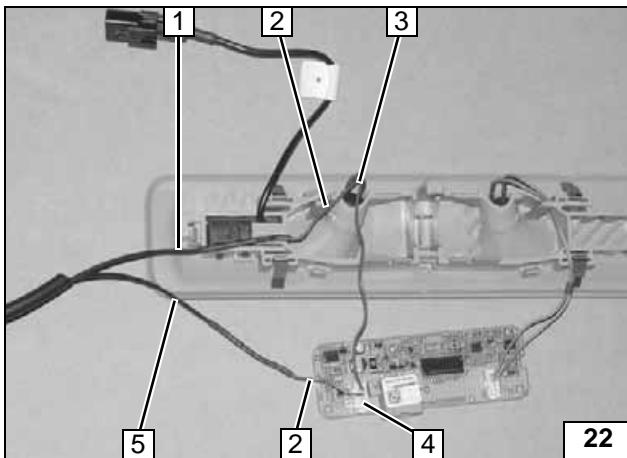

From MY 2011

Connection before the 2-pin connector (4) of the ultrasonic sensor control unit. Cut green (gn) wire (2) and connect with attached black (sw) wires (1) and (5) (solder and insulate). Pull black (sw) wires (1) and (5) into protective sleeving. Produce connections as shown in wiring diagram.

- (3) Ultrasonic sensor R6



Connecting ultrasonic sensor

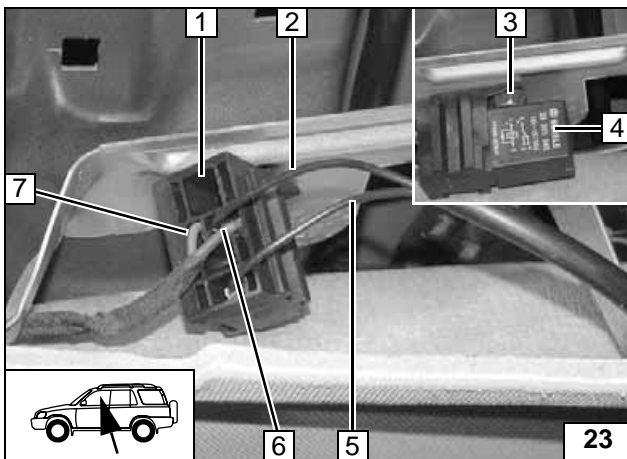

- (1) Socket K3.1 relay
- (2) Black (sw) wire from ultrasound sensor R6
- (3) Original vehicle bolt
- (4) K3.1 relay plugged in
- (5) Black (sw) wire from ultrasound sensor R6
- (6) Extra brown (br) wire K3.1/85
- (7) Red (rt) wire ③ from K3/86

Installing
K3.1 relay

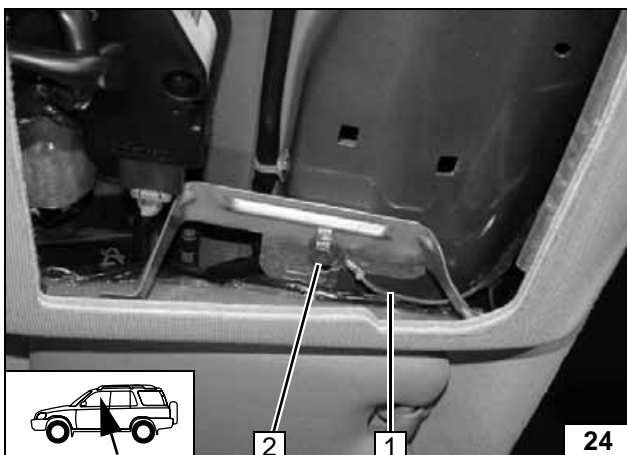

- (1) Brown (br) wire K3.1/85
- (2) Original vehicle bolt

Ground connection
K2 relay

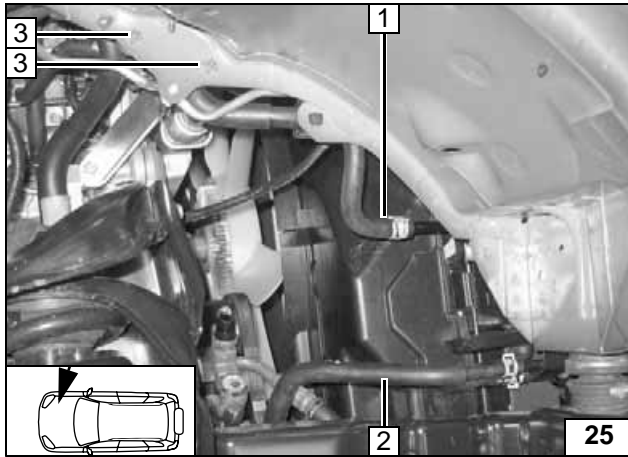
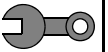

Preparing installation location

- (1) Line from steering reservoir
- (2) Line to automatic-transmission oil cooler
- (3) Bolts from bracket of steering reservoir [2x]

Original state

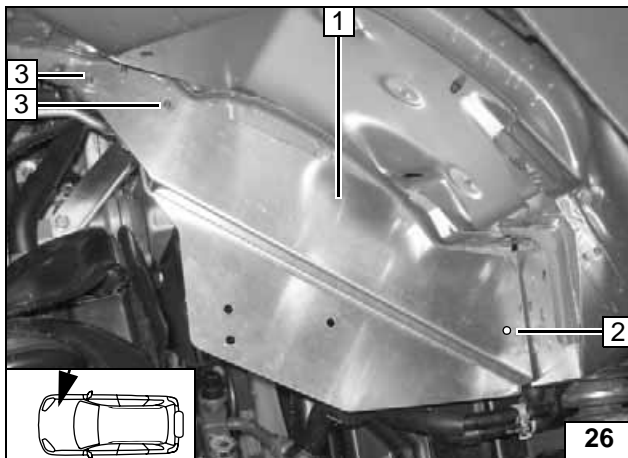

- (1) Adjust bracket as shown
- (2) Copy hole pattern
- (3) Bolts from bracket of steering reservoir [2x]

Preparing installation location

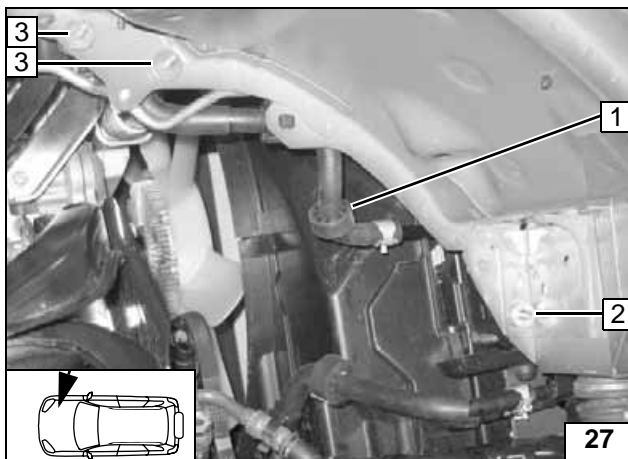

Remove bracket again

- (1) 15mm dia. black (sw) rubber profile
- (2) 6.5 mm dia. hole, M6x20 bolt, large diameter washer (from inside), 5mm shim, pin lock (from outside)
- (3) Bolts replaced with M6x40 bolts, large diameter washers (from inside) and large diameter washers (from outside) [2x]

Preparing installation location

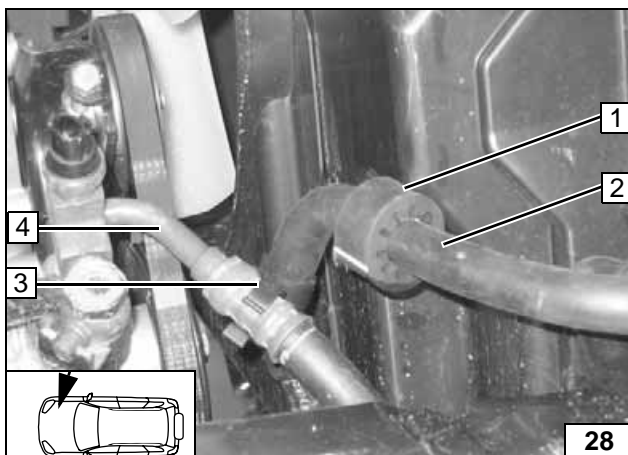

Route line to automatic-transmission oil cooler (2) before steering line (4)

- (1) 20 mm dia. black (sw) rubber profile
- (3) 18/18 double clip

Preparing installation location

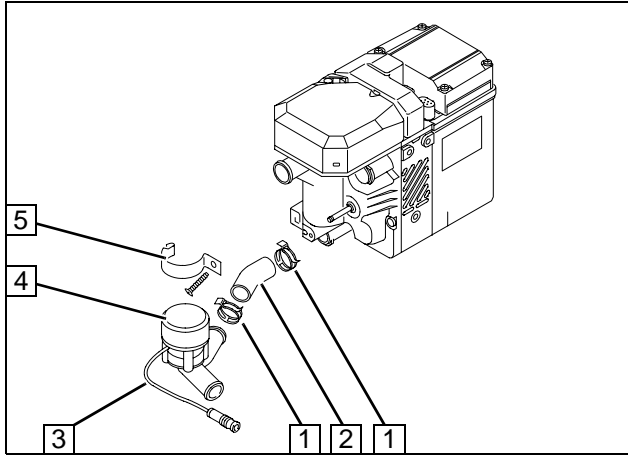
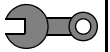

Premounting heater

Open central cap, replace wiring harness of circulating pump with attached 475 mm wiring harness **3**. Spring clips **1** [2x] will be reused. Discard hose section **2** and clamp **5**.

4 Circulating pump

Removing circulating pump

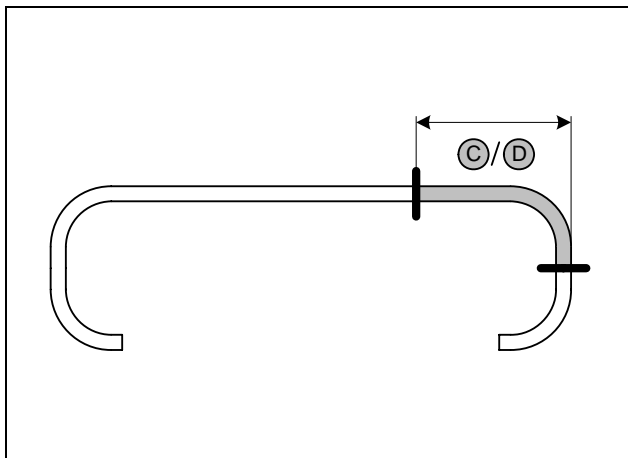

Hose **D** = manual transmission and 140kW automatic transmission

Hose **C** = 126 and 128kW automatic transmission

Remaining sections will be used later

C / D = 130

Cutting hose of heater outlet to length

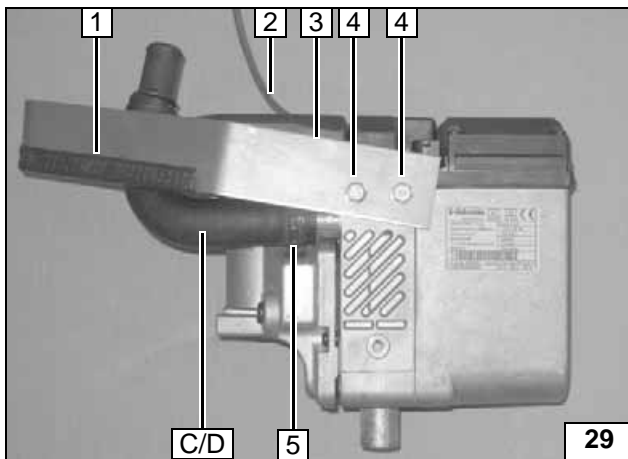

E-jot screws, tightening torque 10 Nm.

- (1) 100mm edge protection
- (2) Extension wiring harness for circulating pump connected
- (3) Strut
- (4) E-jot screws [2x]
- (5) 27 mm dia. spring band clamp

Premounting heater

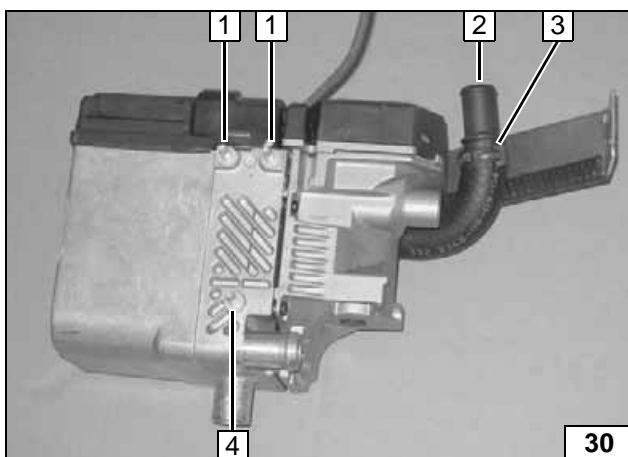

E-jot stud, tightening torque 10 Nm. Insert two washers between heater and E-jot studs at Position **(4)** as height compensation.

- (1) E-jot stud [2x]
- (2) 20/20 connecting pipe
- (3) 27 mm dia. spring band clamp
- (4) E-jot stud, washer [2x]

Premounting heater



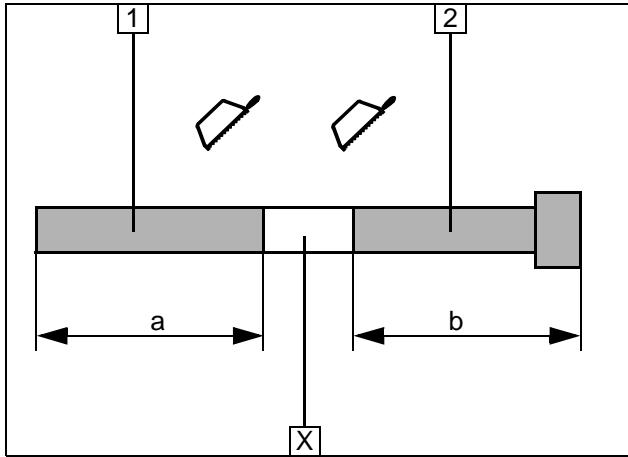
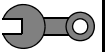

- (1) Exhaust pipe
a = 550 mm
- (2) Exhaust end section
b = 350mm

Discard section X

Cutting exhaust pipe to length

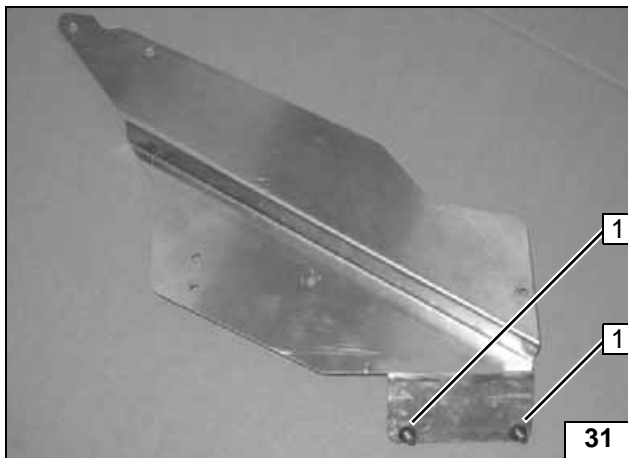

- (1) M6x12 bolt (from below), pin lock (from above) [2x]



Premounting bracket

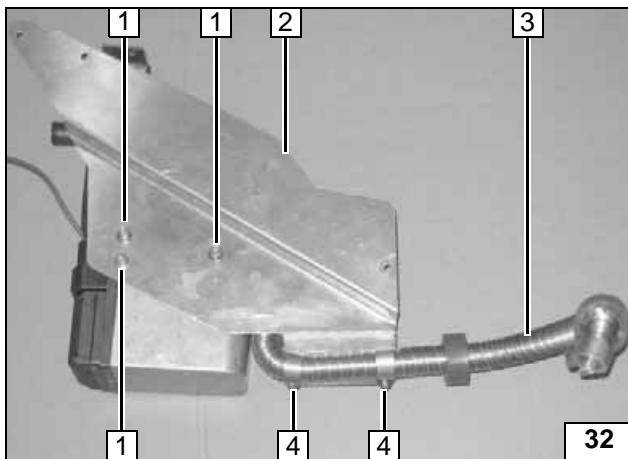

Shape exhaust pipe as shown.
Only loosely mount all components.

- (1) Flanged nut [3x]
- (2) Bracket
- (3) Exhaust pipe
- (4) P-clamp, flanged nut [2x]



Premounting exhaust pipe

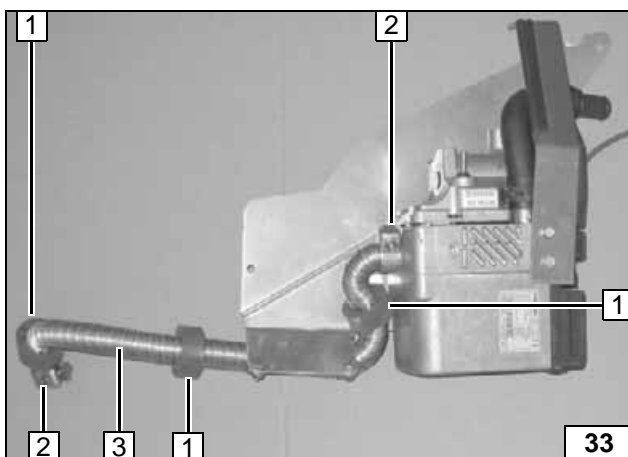

Remove bracket and exhaust pipe from heater again after installation.

- (1) Red (rt) rubber profile [3x]
- (2) Hose clamp [2x]
- (3) Exhaust pipe



Premounting exhaust pipe

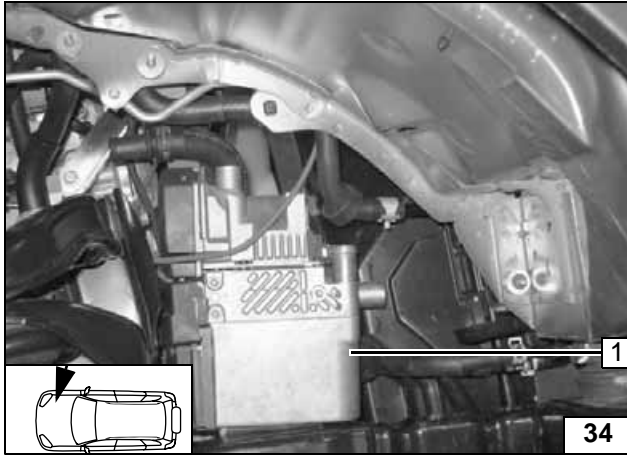
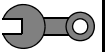

Installing Heater

Connect wiring harness on heater.

- (1) Heater



Installing heater

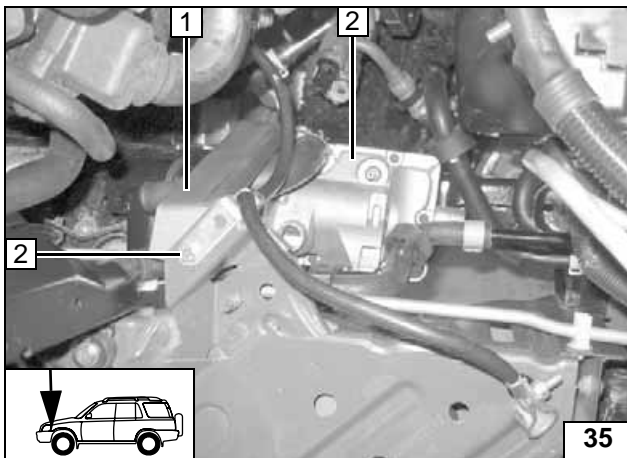

Up to MY 2010

- (1) Strut loosely mounted on bolt (3) with flanged nut
- (2) Original vehicle bolt replaced with M6x20 bolt, washer



Installing heater

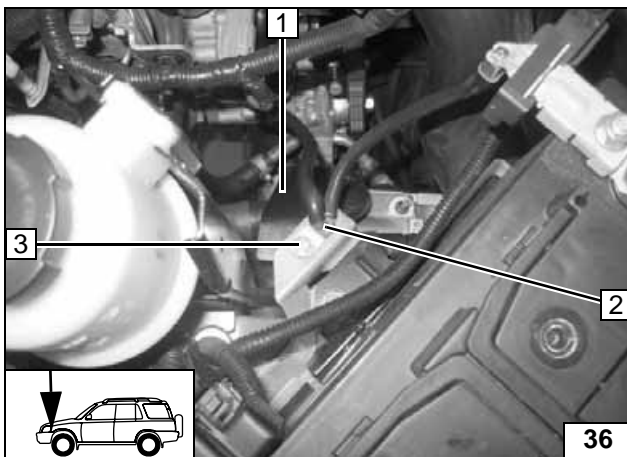

From MY 2011

- (1) Strut loosely mounted on bolt (3) with flanged nut
- (2) Original vehicle bolt replaced with M6x20 bolt, washer
- (3) Turn and install earth point



Installing heater





Coolant circuit of manual transmission and 140kW automatic transmission

WARNING!

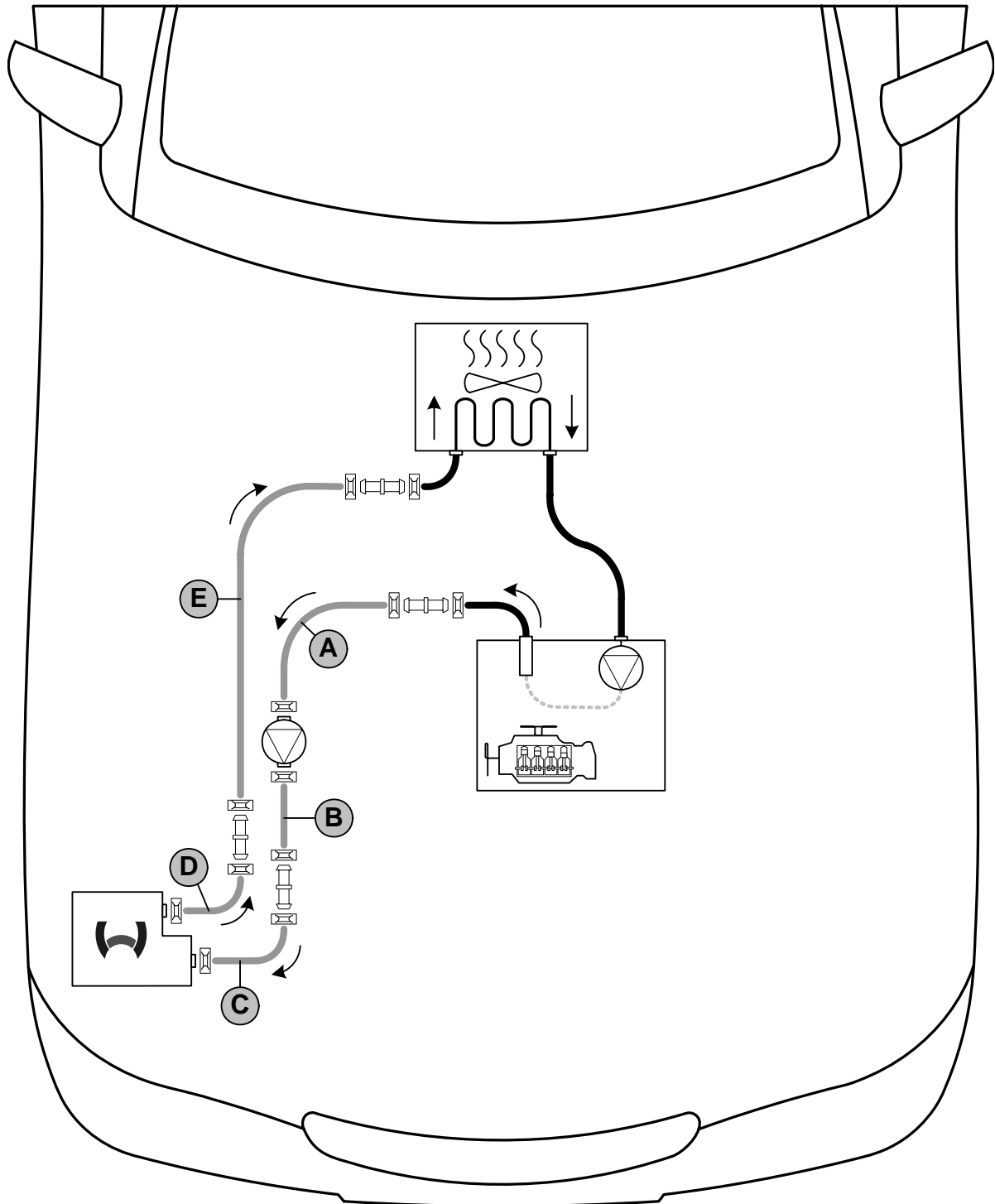
Any coolant running off should be collected in an appropriate container. Install hoses so that they are kink-free. Unless specified otherwise, always fasten using cable ties. Position clamps so that other hoses cannot be damaged. The heater must be filled with coolant when installing the coolant hose. The connection should be "inline" based on the following diagram



Hose routing diagram

All spring clips  = 27mm dia.
 All connecting pipes  = dia. 20x20.



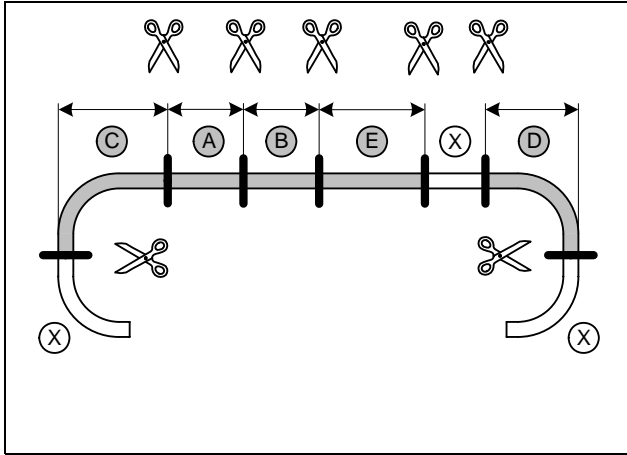
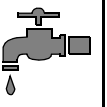

Preparing hoses

Hose **D** is already mounted on heater.
Discard sections **X**.

- A** = 270mm
- B** = 300mm
- C** = 120mm
- E** = 430mm



Cutting hoses to length

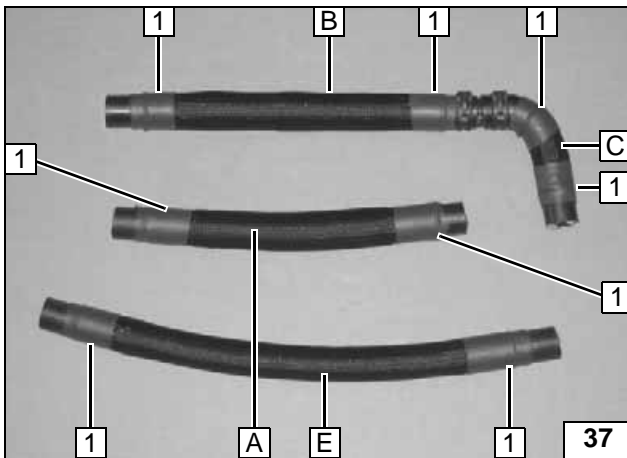

Push braided protection hose onto hose **A**, **B**, **C** and **E** and cut to length.
Connect hose **B** and **C**.

(1) Heat shrink plastic tubing [8x]



Premounting hoses

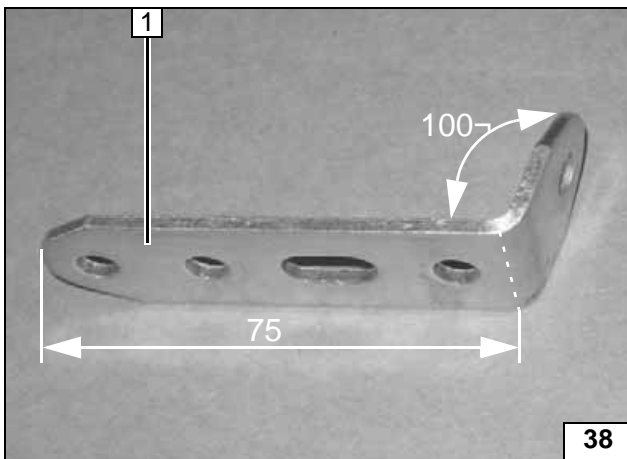

Long hole spacing at Position (1).



Bending perforated bracket



Observe direction of flow.

- (1) Intake side
- (2) 48 mm dia. rubber-coated p-clamp
- (3) M6x20 bolt, flanged nut
- (4) Perforated bracket



Premounting circulating pump

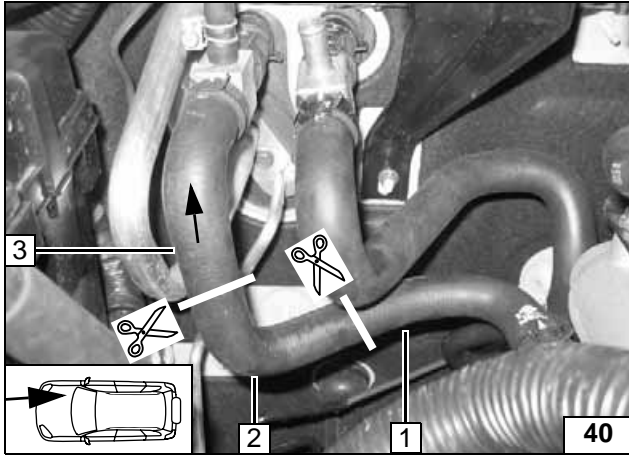

- (1) Hose section on engine outlet
- (2) Discard section
- (3) Hose section on heat exchanger inlet

Cutting point

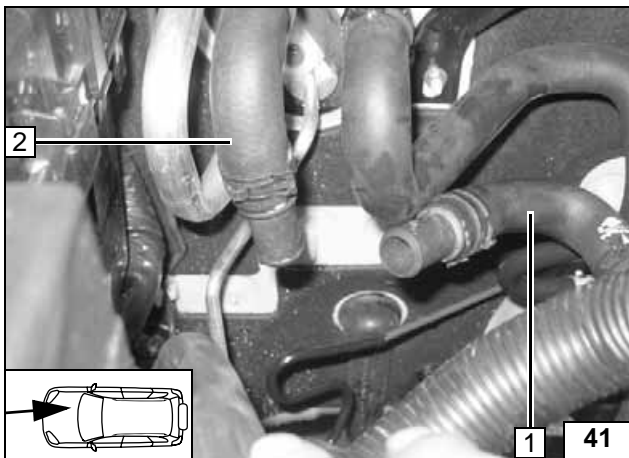

- (1) Hose section on engine outlet
- (2) Hose section on heat exchanger inlet

Mounting connection pipes

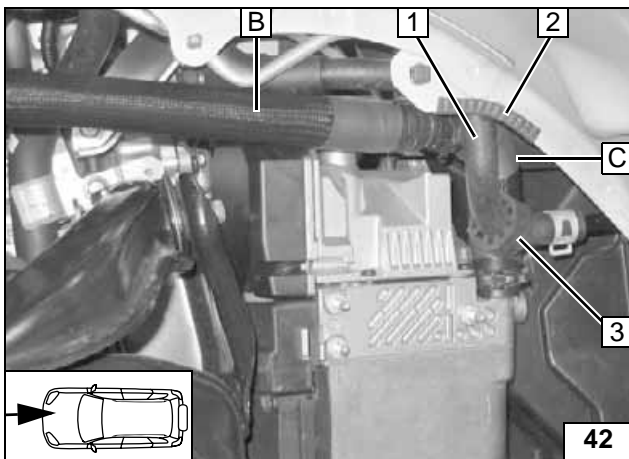

Align line (1) and rubber profile (3) as shown.

- (2) 50mm edge protection



Connection to heater inlet

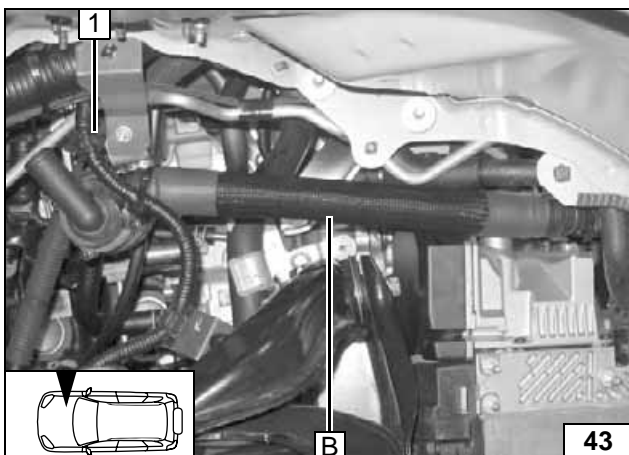

- (1) Unclip wiring harness

Installation location of circulating pump

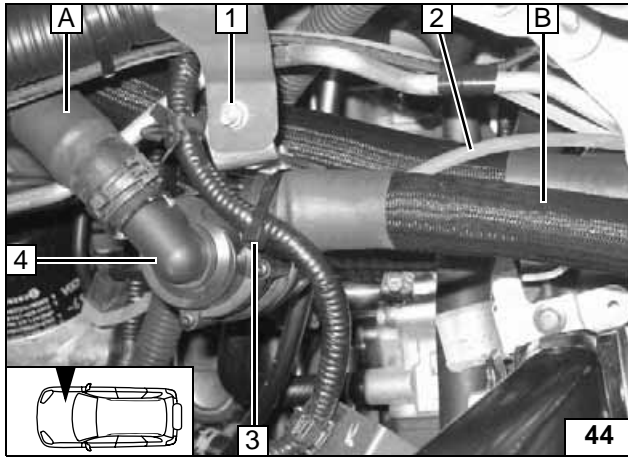

Observe direction of flow. Pressure side faces toward heater.

- (1) M6x12 bolt, large diameter washer, perforated bracket, flanged nut
- (2) Mount wiring harness of circulating pump
- (3) Wiring harness fastened with cable tie
- (4) Circulating pump, premounted



Installing circulating pump

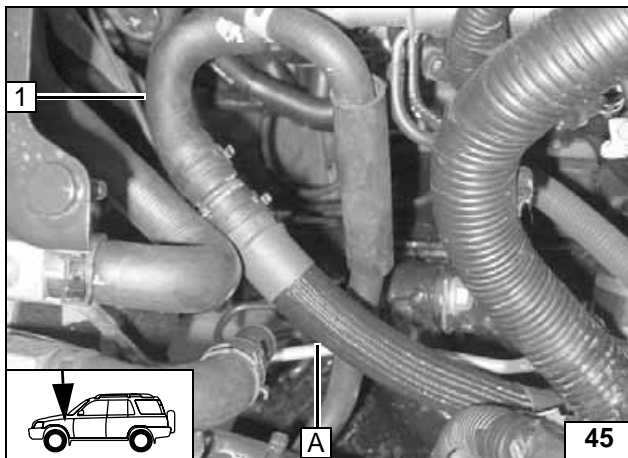

- (1) Hose section on engine outlet

Connecting engine outlet

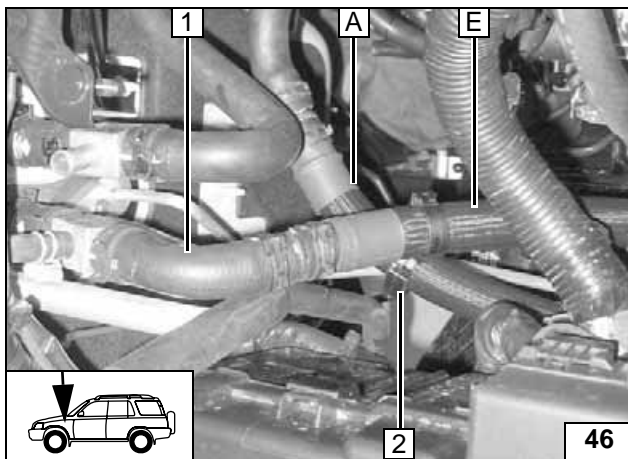

Fill the coolant hoses with coolant before connecting.

- (1) Hose section on heat exchanger inlet
- (2) 27x27 double clip



Connection to heat exchanger inlet

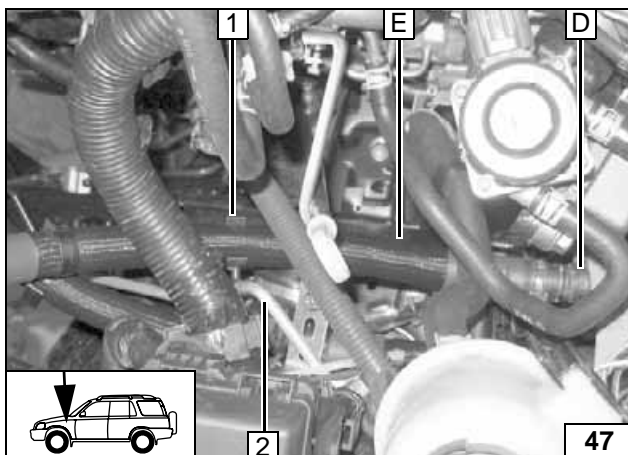

Check positioning of coolant hoses A, B, C, D, E and circulating pump and correct if necessary.

- (1) 8x25 double clip on E and A/C line
- (2) A/C line



Connection to heater outlet



Coolant circuit 126 and 128kW automatic transmission



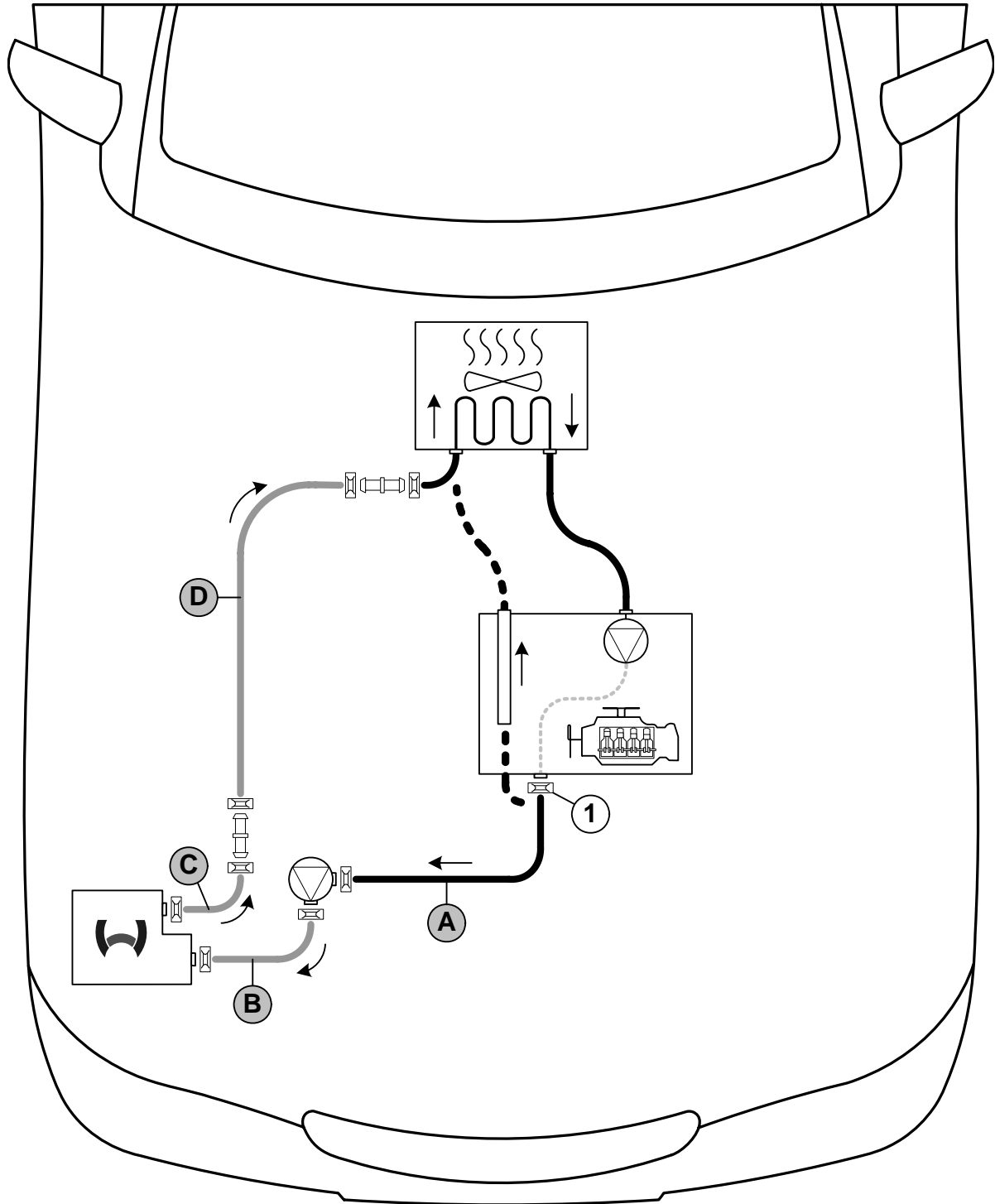

WARNING!

Any coolant running off should be collected in an appropriate container. Install hoses so that they are kink-free. Unless specified otherwise, always fasten using cable ties. Position clamps so that other hoses cannot be damaged. The heater must be filled with coolant when installing the coolant hose. The connection should be "inline" based on the following diagram



Hose routing diagram

Hose **A** = original vehicle hose. **1** = Original vehicle spring clip .
 All spring clips without a specific designation  = 27mm dia.
 All connecting pipes  = dia. 20x20.



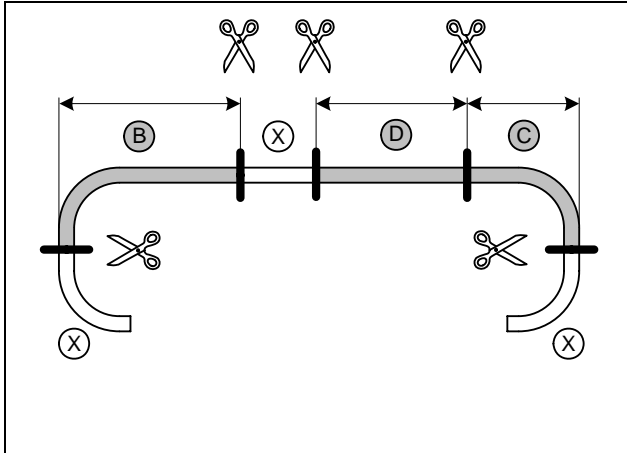

Hose **C** is already mounted on heater.
Hose **A** = original vehicle hose.
Discard sections **X**.

B = 270mm
D = 450mm



Cutting hoses to length

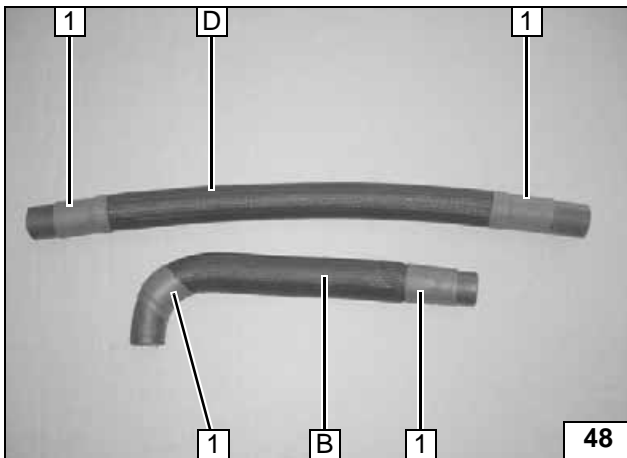

Push braided protection hose onto hose **B** and **D** and cut to length.

(1) Heat shrink plastic tubing [4x]



Premounting hoses

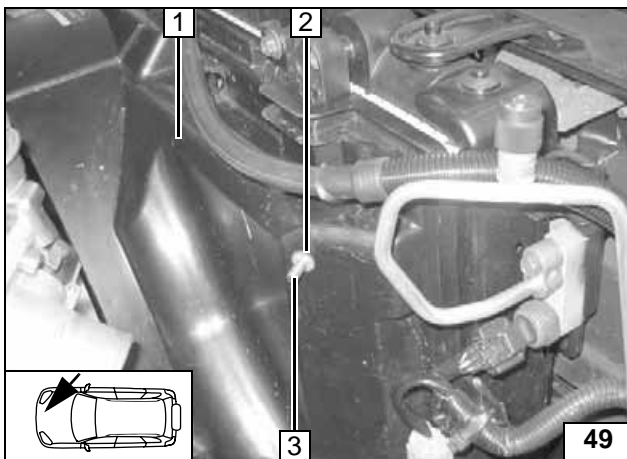

Do not damage radiator.

- (1) Detach radiator trim
- (2) 6.5 mm dia. hole
- (3) M6x20 bolt, large diameter washer (from inside), pin lock (from outside)



Installing circulating pump

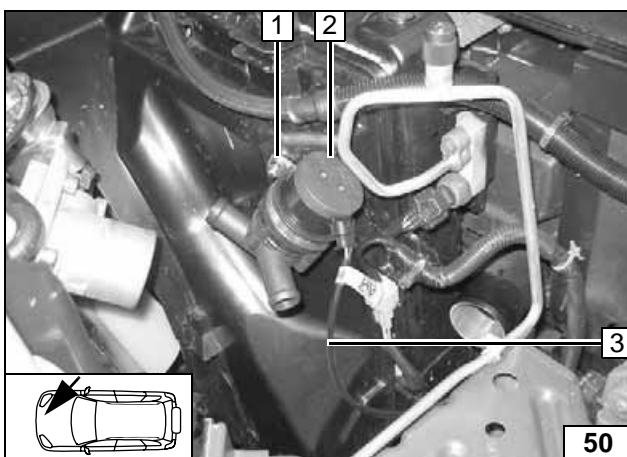

Observe direction of flow. Pressure side faces toward heater.

- (1) 48 mm dia. rubber-coated p-clamp, flanged nut
- (2) Circulating pump
- (3) Wiring harness of circulating pump



Installing circulating pump

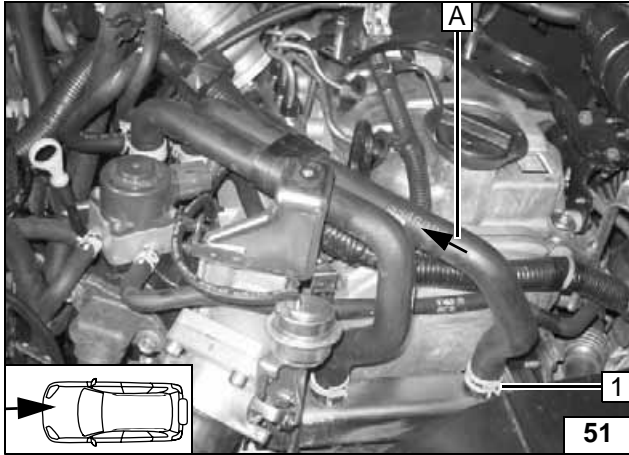
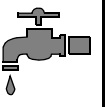

Remove hose **A**. Hose **A** and clamp **(1)** will be reused.



Removing original hose

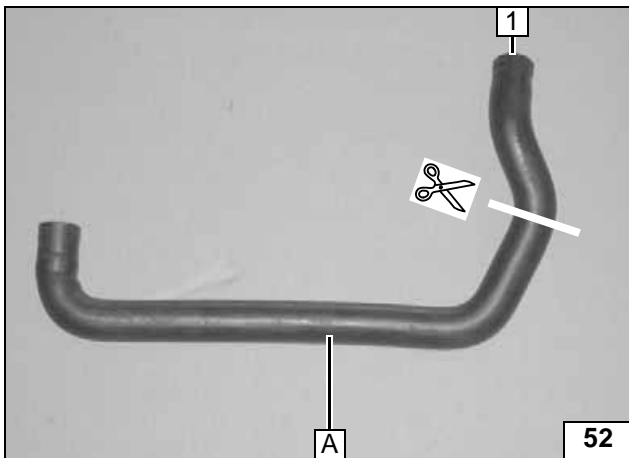

(1) Discard section

Cutting point

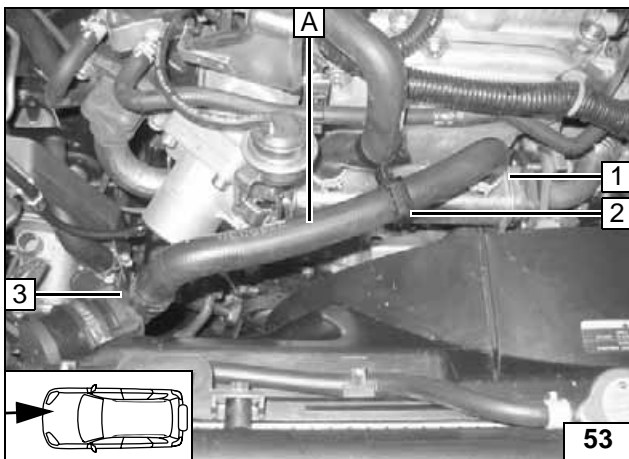

Side of hose **A** cut to length is connected to intake side of circulating pump

- (1)** Engine outlet
- (2)** 27x27 double clip
- (3)** Intake side of circulating pump



Connecting engine outlet and circulating pump

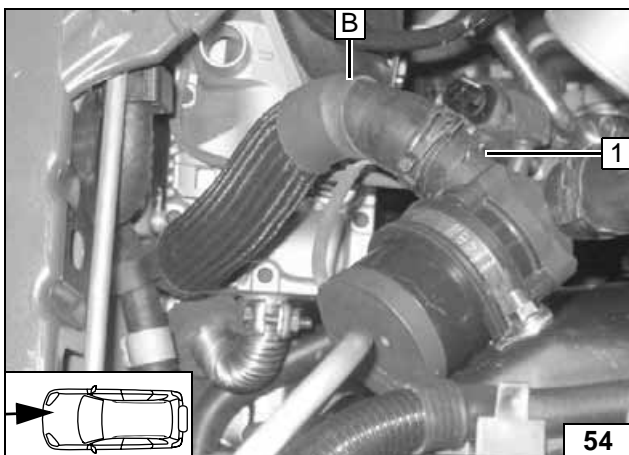

(1) Pressure side of circulating pump

Connecting pressure side of circulating pump

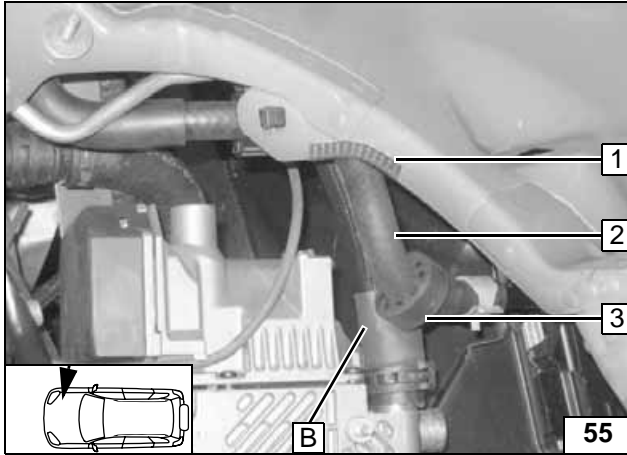

Align line of steering reservoir (2) and pre-mounted rubber profile (3) as shown.

(1) 50mm edge protection



Con-
nection to
heater in-
let

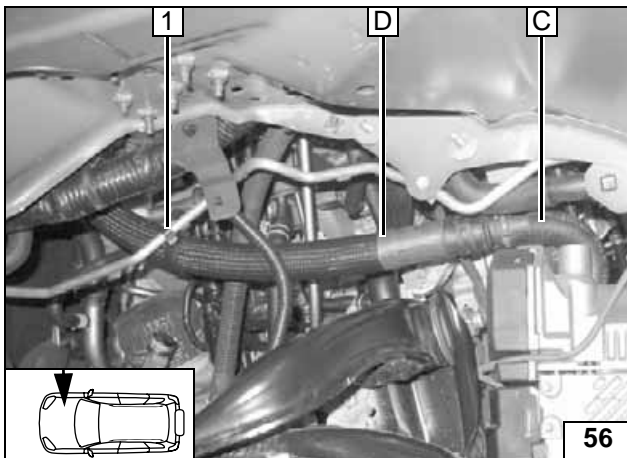

(1) 8x25 double clip on D and A/C line

Con-
nection to
heater out-
let

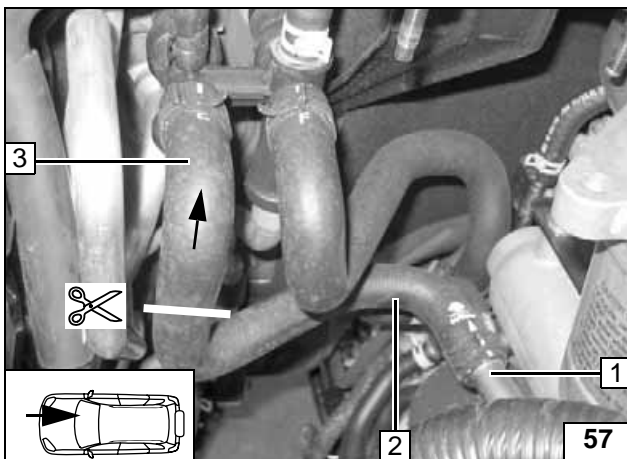

Before removing the hose, check the direction of flow of the original vehicle heat exchanger.

Pipe (1) remains without function.

(2) Discard hose section

(3) Hose section on heat exchanger inlet



Cutting
point

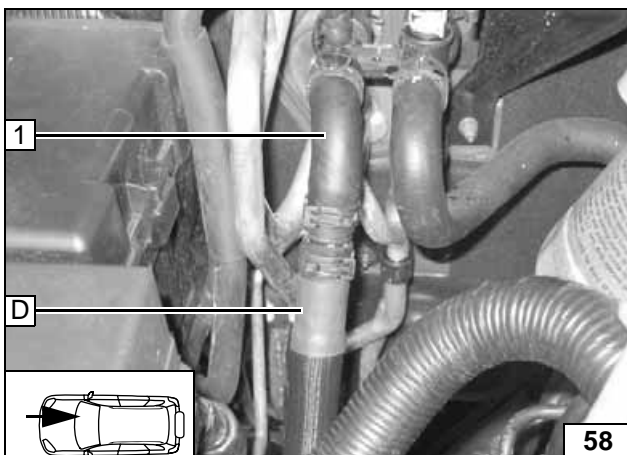

Fill the coolant hoses with coolant before connecting. Check positioning of coolant hoses A, B, C, D and circulating pump and correct if necessary.

(1) Hose section on heat exchanger inlet



Con-
nection to
heat ex-
changer
input

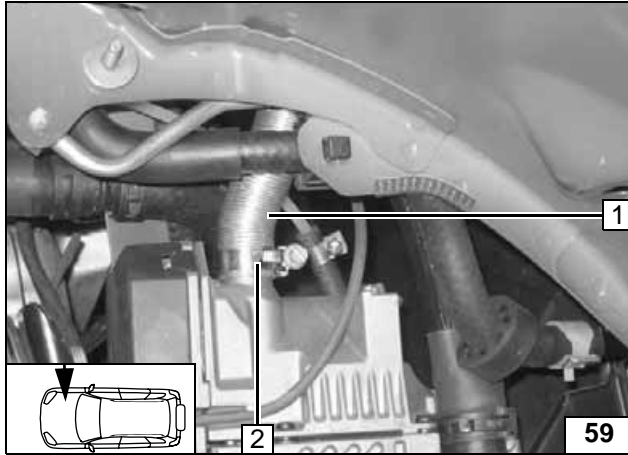
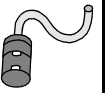

Combustion air

- (1) Combustion air pipe (slotted side on heater)
- (2) 27 mm dia. hose clamp

Installing combustion air pipe

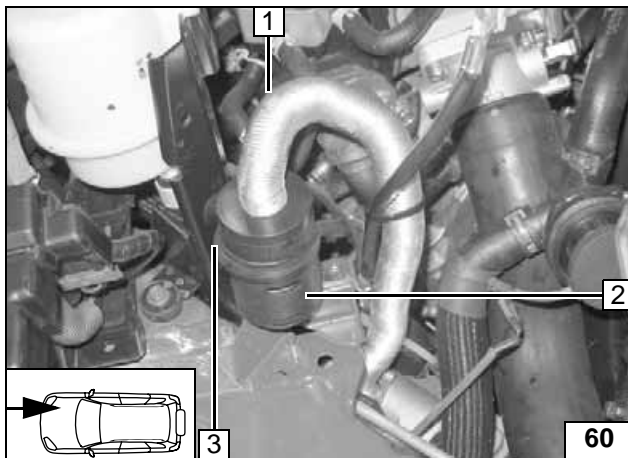

For improved overview, fuse holder is not shown.
Shape combustion air pipe (1) as shown in picture.

- (2) Silencer
- (3) Retaining clip engaged in existing hole



Installing silencer



Fuel

CAUTION!

Open the vehicle's fuel tank cap, ventilate the tank and then re-close the tank lock.

Catch any fuel running off in an appropriate container.

Install fuel line and metering pump wiring harness so that they are protected against stone impact. Unless specified otherwise, always fasten using cable ties.

Mount the fuel line and wiring harness with rub protection on sharp edges.

WARNING!

The fuel line and wiring harness are routed to the metering pump as shown in the wiring harness routing diagram.

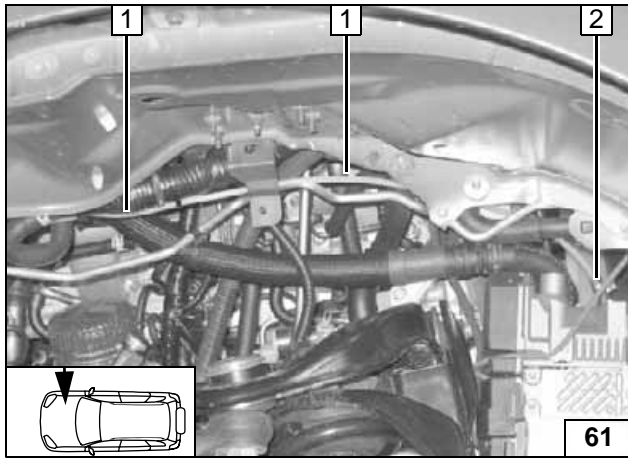

Route Mecanyl line (1) and wiring harness of metering pump along vehicle wiring harness to firewall.

(2) Hose section, 10 mm dia. hose clamp [2x]

Conne-
ction on
heater

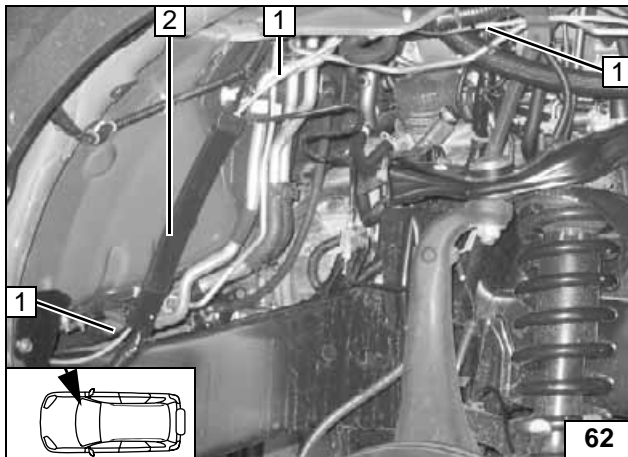

Route Mecanyl line and wiring harness of metering pump (1) downward through cable duct (2).



Installing
lines

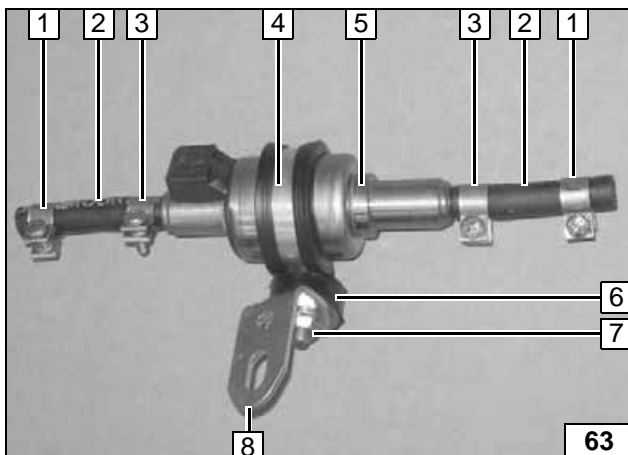

Up to MY 2009

- (1) 10 mm dia. hose clamp [2x] loosely mounted
- (2) Hose section [2x]
- (3) 10 mm dia. hose clamp [2x]
- (4) Rubber-coated p-clamp
- (5) Metering pump
- (6) Silent block
- (7) Flanged nut [2x]
- (8) Angle bracket

Premount-
ing meter-
ing pump

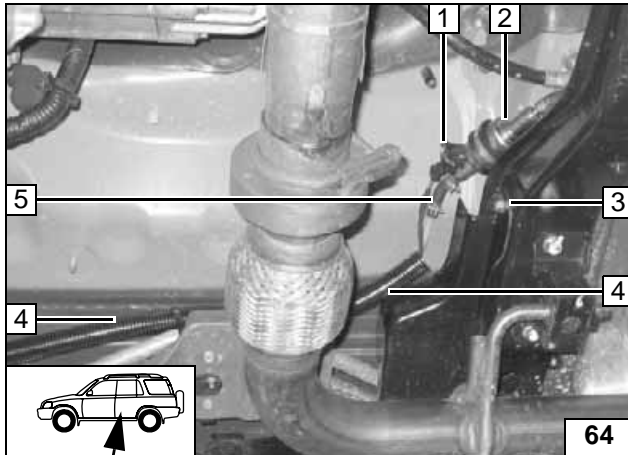

Ensure proper installation position of metering pump, see "Installation Instructions". Fuel line from heater on pressure side of metering pump [side with connector]. Route Mecanyl line and wiring harness of metering pump in included corrugated tube (4).

- (1) Wiring harness of metering pump, connector housing completed
- (2) Pre-mounted metering pump
- (3) Original vehicle bolt, flanged nut
- (5) Mecanyl line, 10 mm dia. hose clamp tightened



Installing metering pump

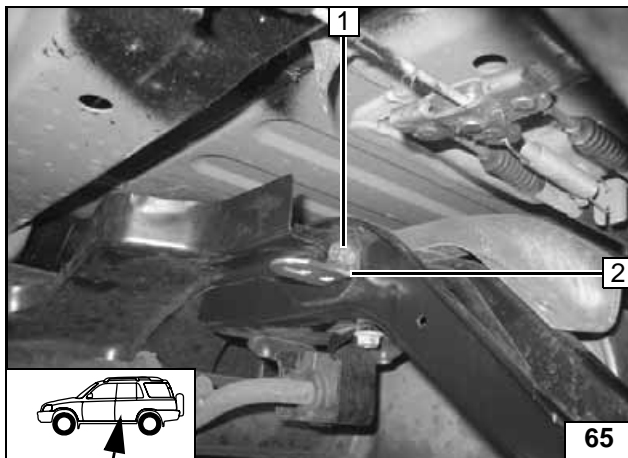

From MY 2010

- (1) Original vehicle bolt
- (2) Angle bracket

Installing angle bracket

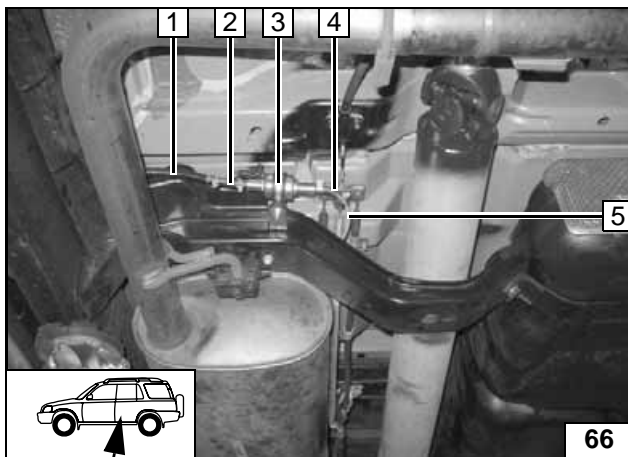

- (1) Corrugated tube, fuel line, metering pump wiring harness
- (2) Hose section, clamp [2x]
- (3) Rubber-coated p-clamp, silent block, nut
- (4) Hose section, clamp [2x]
- (5) Fuel line



Installing metering pump

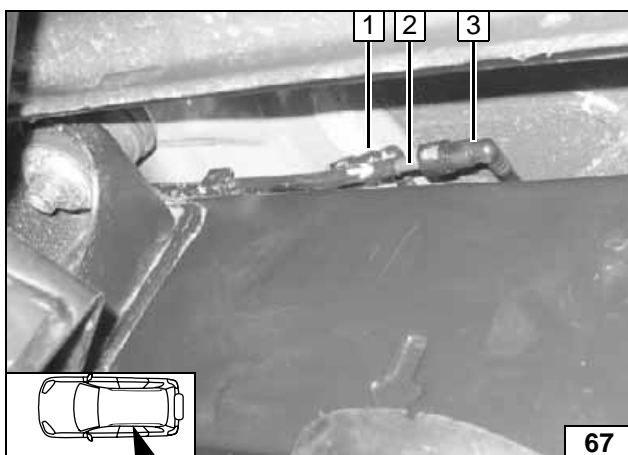

All vehicles

Fuel is removed from return line. Disconnect return line at coupling.

- (1) Supply line
- (2) Return line from fuel cooler
- (3) Return line to fuel tank



Fuel removal

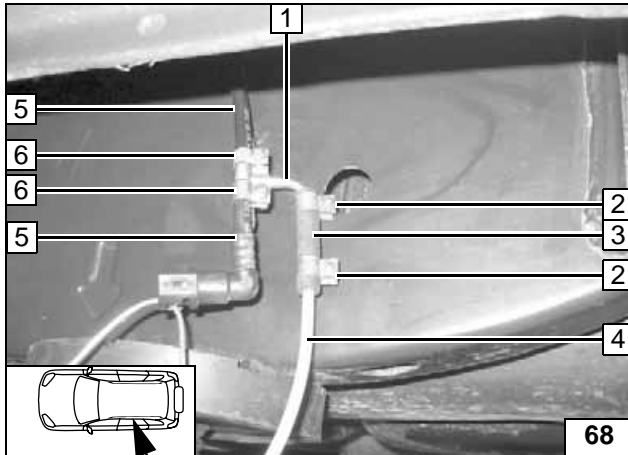

Cut off return line (5) as shown. Reconnect return line (5) and route Mecanyl line (4) along original vehicle fuel lines to metering pump.

- Return line
- (1) Metal 6x5x6 T-piece
 - (2) 10 mm dia. hose clamp [2x]
 - (3) Hose section
 - (6) 8mm dia. hose clamp [2x]



Fuel removal

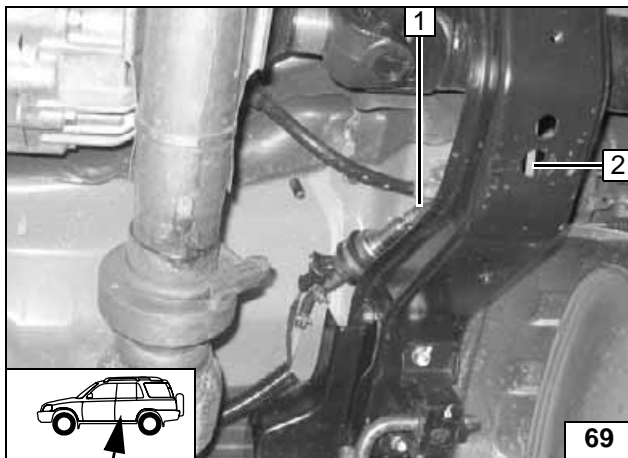

Fuel line from T-piece (2) on intake side of metering pump [side without connector]. Align Mecanyl line and wiring harness of metering pump over entire length and fasten with cable ties. Check the position of the components; adjust if necessary. Check that they have freedom of movement.

- (1) Hose section, 10 mm dia. hose clamp tightened



Connection to metering pump

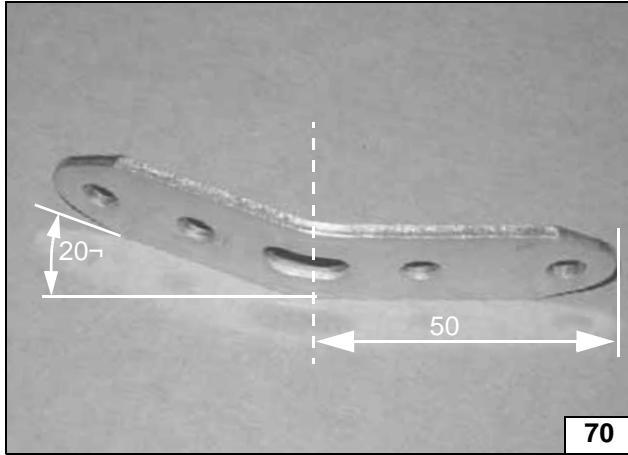
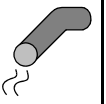

Exhaust gas

Bend perforated bracket as shown.



Bending perforated bracket

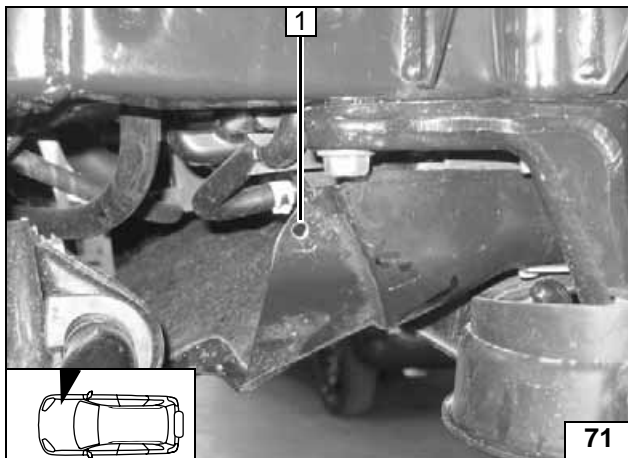

(1) 6.5 mm dia. hole

Hole in under-ride protection

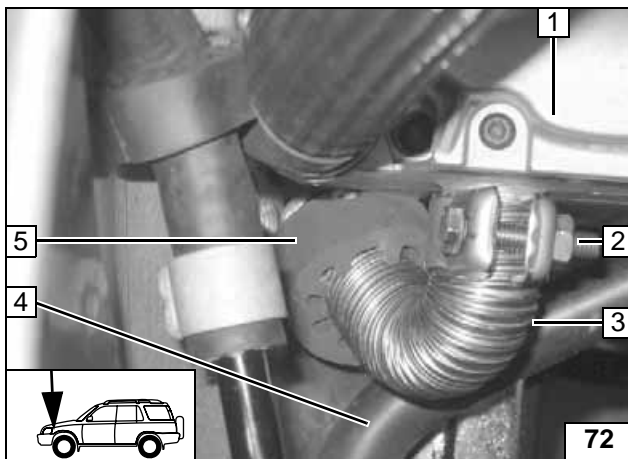

First guide preshaped exhaust pipe to heater, then insert bracket.
Position red (rt) rubber isolator (5) in the area of the line to transmission oil cooler (4).

- (1) Heater
- (2) Hose clamp
- (3) Exhaust pipe (premounted)



Installing exhaust pipe

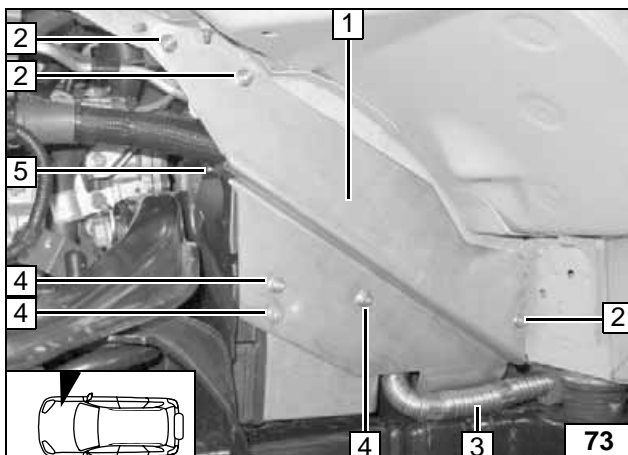

Ejot stud, tightening torque 10 Nm.
Position exhaust pipe (3) as shown.
Cut included 4.5 mm dia. fuel hose to length and connect to Ejot stud (4) as rub protection [3x].

- (1) Bracket
- (2) Flanged nut on premounted bolt [3x]
- (4) Flanged nut on Ejot stud bolt [3x]
- (5) 30 mm edge protection



Installing bracket

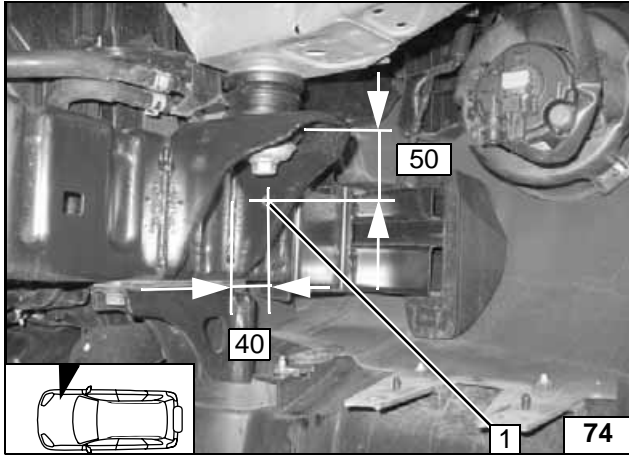

(1) 6.5mm dia. hole, if it does not exist

Hole

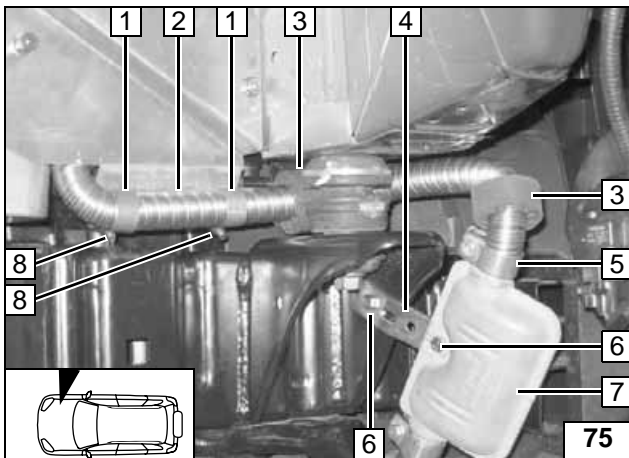

Fasten long hole spacing of perforated bracket (4) on silencer (7) . Position rubber isolator (3) as shown [2x].

- (1) P-clamp [2x]
- (2) Exhaust pipe
- (5) Hose clamp
- (6) M6x20 bolt, large diameter washer, flanged nut [2x]
- (8) Flanged nut on premounted bolt [2x]



Installing exhaust pipe and silencer

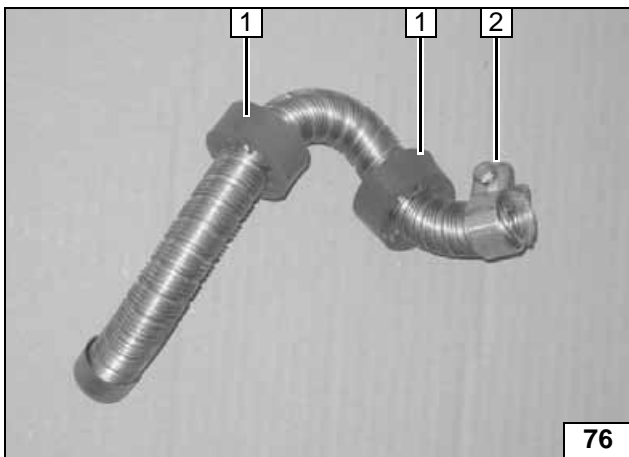

Shape exhaust end section as shown.

- (1) Red (rt) rubber profile [2x]
- (2) Hose clamp loosely mounted



Premounting exhaust end section

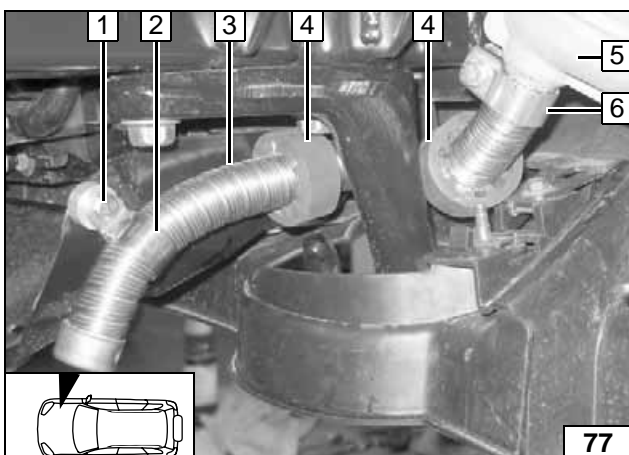

Position rubber isolator (4) as shown [2x].

- (1) M6x20 bolt, 10 mm shim, flanged nut
- (2) P-clamp
- (3) Exhaust end section
- (5) Silencer
- (6) Hose clamp



Installing exhaust end section

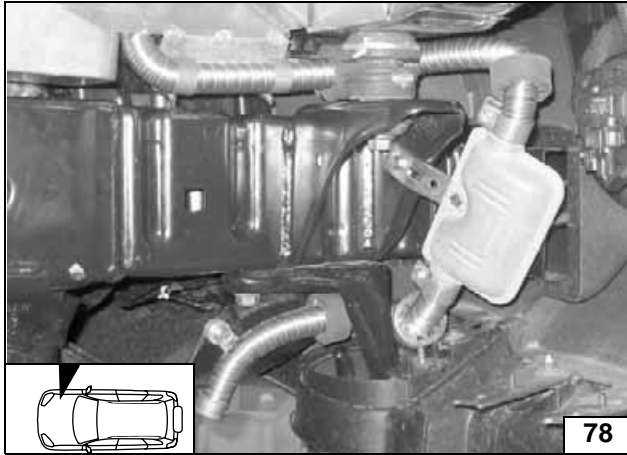
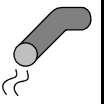

78

Check positioning of exhaust pipe and t-pipe end section over entire length and position of silencer and protective rubber isolators [5x] and correct if necessary.

In particular, ensure sufficient distance between exhaust pipe, exhaust pipe end section and silencer and original vehicle lines and plastic parts.



Positioning exhaust system

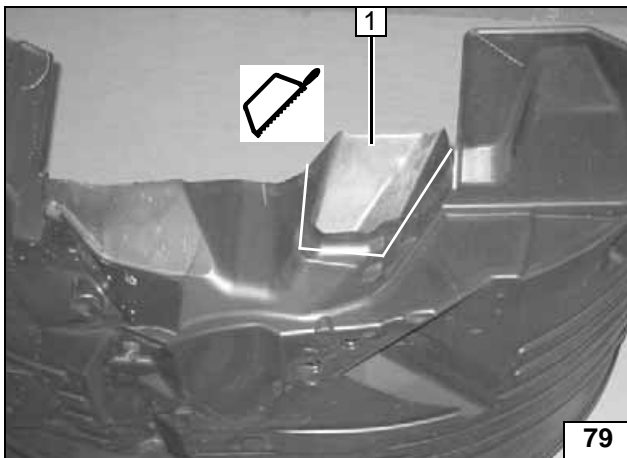

79

Installing wheel well trim

Cut out wheel well trim as shown.

(1) Discard section



Cutting out wheel well trim



80

Rework cut-out if necessary.



Installing wheel well trim

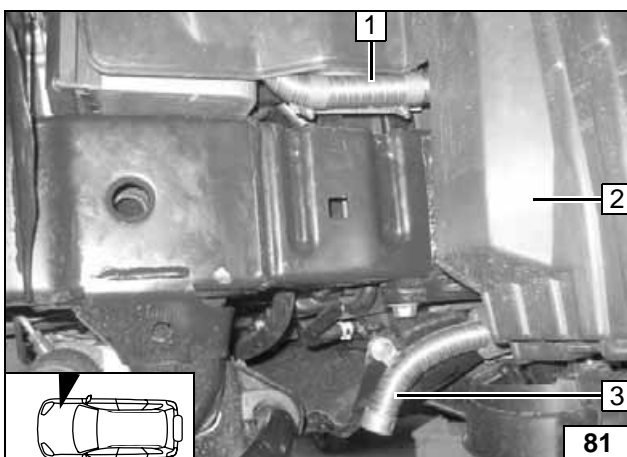

81

Ensure sufficient distance between wheel well trim and exhaust system. If necessary, cut out wheel well trim accordingly.

- (1) Exhaust pipe
- (2) Wheel well trim
- (3) Exhaust end section



Installing wheel well trim

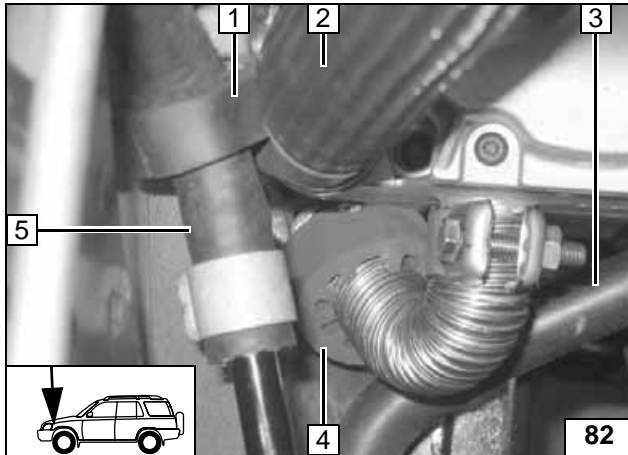
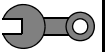

Final Work

Position rubber profiles and lines as shown.

- (1) Black (sw) rubber profile positioned on hose of heater inlet (2)
- (3) Line to automatic-transmission oil cooler
- (4) Red (rt) rubber profile positioned on line (3)
- (5) Line from steering reservoir



Positioning rubber profiles and lines

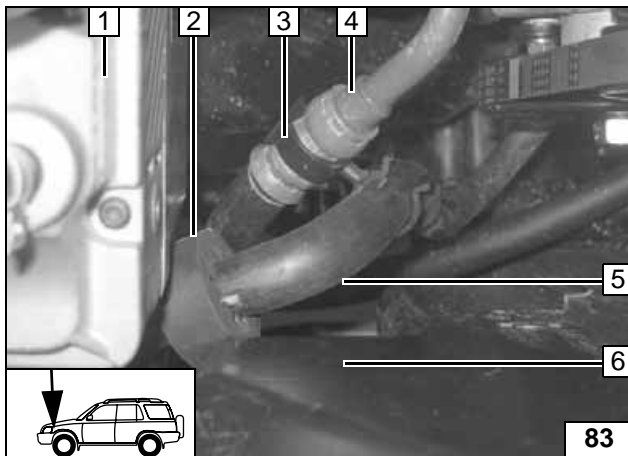

Position rubber isolator, lines and spacer bracket as shown.

- (1) Heater
- (2) Black (sw) rubber profile positioned between heater and radiator trim (6)
- (3) Spacer bracket
- (4) Steering line
- (5) Line to transmission oil cooler
- (6) Radiator trim



Positioning rubber profiles and lines

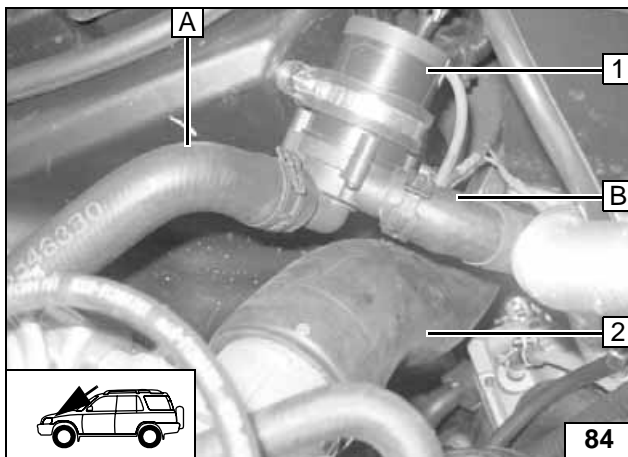

Only with automatic transmission

Ensure freedom of movement of intake hose. If necessary, correct position of circulating pump and hose **A** and **B**.

- (1) Circulating pump
- (2) Intake hose



Installing intake hose

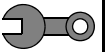

WARNING!

Mount removed parts in reverse order. Check all hoses, clamps and all electrical connections for firm seating. Insulate all loose lines and tie back.

Only use manufacturer-approved coolant. Spray the heater components with anti-corrosion wax (Tectyl 100K, Order No. 111329).

- **Connect the battery.**
- **Fill and bleed the coolant circuit according to the vehicle manufacturer's specifications.**
- **Adjust digital timer, teach Telestart transmitter**
- **Make settings on A/C control panel according to the "Operating Instructions for End Customer".**
- **Apply the sticker "Switch off parking heater before refilling" in the area of the filler neck**
- **See installation instructions for initial start-up and function check**



Note:

The level in the expansion tank can fluctuate during the heating mode.



Webasto
Feel the drive

Webasto AG
Postfach 80
D-82132 Stockdorf / Germany
National Hotline: 01805 93 22 78
(14 Cent aus dem deutschen Festnetz)
Hotfax: 0395 5592 353
Hotmail: technikcenter@webasto.com
<http://www.webasto.com>

Operating Instructions for End Customer

Please remove page and add to the vehicle operating instructions.

Note:

The level in the expansion tank can fluctuate during the heating mode.

We recommend matching the heating time to the driving time.

Heating time = driving time

Example:

For a driving time of approx. 20 min. (in one direction), we recommend not exceeding a switch-on time of 20 min.

On vehicles with passenger compartment monitoring, the ultrasound passenger compartment monitoring is deactivated simultaneously with the control of the passenger compartment fan to prevent an alarm from being triggered.

Before parking the vehicle, make the following settings:

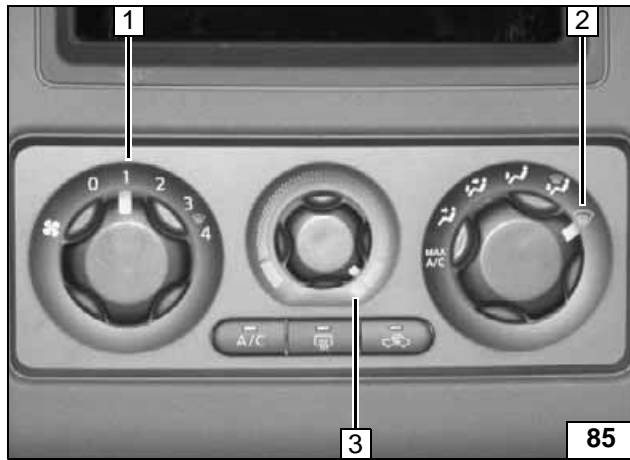

- (1) Set fan to level "1", or possibly "2"
- (2) Air outlet to windscreen
- (3) Temperature to "max."

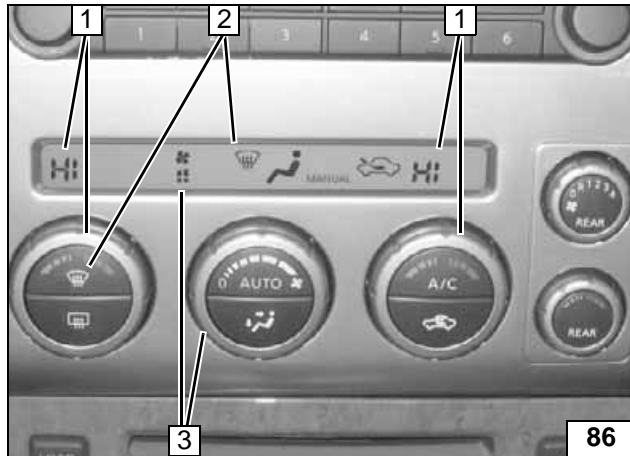

- (1) Temperature to "HI." [2x]
- (2) Direct air outlet toward windscreen
- (3) Set fan speed to level 2 (possibly to 3)



- (1) Set temperature to "32°C" [2x]
- (2) Direct air outlet toward windscreen
- (3) Set fan speed to level 2 (possibly to 3)



Manual air conditioning

Automatic air-conditioning

Automatic air-conditioning navigation system