

Water Heater



Thermo Top E Parking Heater  00 0003

Installation documentation

Ford Focus / Focus C-MAX / Focus CC

Petrol

from Model Year 2004

For left-hand drive vehicles only



WARNING!

Hazard warning:

Incorrect installation or repair of Webasto heating systems may cause a fire or result in the emission of carbon monoxide, which can be fatal. Serious or fatal injuries can be caused as a result.



Specialist company training, technical documentation, specialised tools and equipment are required to install and repair Webasto heating and cooling systems. Only original Webasto parts must be used. For this, also see the catalog of air and water heater accessories from Webasto.

NEVER attempt to install or repair Webasto heating or cooling systems if you have not successfully completed the company training and thereby acquired the required technical skills, or if you do not have access to the required technical documentation, tools and equipment needed to carry out correct installation and repairs.

ALWAYS follow all Webasto installation and repair instructions and observe all warnings.

The initial startup is to be executed with the Webasto Thermo Test Diagnosis.

Webasto does not accept any liability for defects and damage that are attributable to installation by untrained staff.

Ford Focus / Focus C-MAX / Focus CC

Table of contents

Validity	2	Preparing installation location	16
Heater/installation kit	3	Premounting heater	18
Foreword	3	Fastening for underride protection	19
General instructions	3	Installing heater	19
Special tools	3	Coolant circuit	21
Preliminary work	5	Fuel	23
Heater installation location	5	Mounting underride protection	26
Preparing electrical system	6	Final Work	27
Electrical system of Focus	7	Operating instructions for end customer	28
Electrical system for Focus/Focus CC from 2008	8		
Electrical system of C-Max	9		
Fan control without automatic A/C	10		
Automatic A/C fan control	11		
Additionally for automatic A/C from 01/06	13		
Remote option (Telestart)	15		

Validity

Manufacturer	Model	Type	EG-BE-No. / ABE
Ford	Focus	DA3	e13*2001 / 116*0144
Ford	Focus	DB3	e13*2001 / 116*0144
Ford	Focus C-MAX	DM2	e13*2001 / 116*0109
Ford	Focus CC	DB3	e13*2001 / 116*0157

Engine type	Engine model	Output in kW	Displacement in cm ³
ASDA	Petrol	59	1388
ASDB	Petrol	59	1388
HWDB	Petrol	74	1596
HXDA	Petrol	85	1596
Q7DA	Petrol/Flexifuel	92	1798
QQDB	Petrol	92	1798
AODA	Petrol	107	1999
AODB	Petrol	107	1999

Vehicle and engine types, equipment variants and national specifications not listed in this installation documentation have not been tested. However, installation according to this installation documentation may be possible.

The installation location of a digital timer and summer/winter switch should be confirmed with the end customer before installation.

Ford Focus / Focus C-MAX / Focus CC

Heater/installation kit

Quantity	Designation	Order No.:
1	Ford Delivery Scope for Focus/ Focus C-MAX Petrol without heater control	1303858C
1	Original fuel standpipe with Ford Finis Code	1233999

Additionally required optional heater control:

Quantity	Designation	Order No.:
1	Digital timer	See price list
1	Telestart	See price list

Additionally required with automatic air-conditioning up to 2005 Model Year:

Quantity	Designation	Order No.:
1	Kit for automatic air-conditioning on Ford Focus/Focus C-MAX	9012822A

Additionally required with automatic air-conditioning from 2006 Model Year:

Quantity	Designation	Order No.:
1	Kit for automatic air-conditioning on Ford Focus/Focus C-MAX	9015495A

Foreword

This installation documentation applies to Ford Focus / Focus C-MAX / Focus CC vehicles with Petrol engine - for validity, see page 2 - from model year 2004 and later, assuming technical modifications to the vehicle do not affect installation, any liability claims excluded. Depending on the vehicle version and equipment, modifications may be necessary during installation with respect to this installation documentation.

However, where this is the case, the stipulations in this "installation documentation" the "operating instructions" and "installation instructions" of the *Thermo Top E* should be observed.

The corresponding rules of technology and any information from the vehicle manufacturer should be observed during the installation work.

General instructions

Installation should be carried out according to the general, standard rules of technology. Unless specified otherwise, fasten hoses, lines and wiring harnesses to original vehicle lines and wiring harnesses using cable ties.

Sharp edges must be provided with rub protection (cut-open fuel hose)!

Spray unfinished body areas, e.g. drilled holes, with anti-corrosion wax (Tectyl 100K, Order No. 111329).

When installing an IPCU, the corresponding settings must be checked or adjusted before installation.

Special tools

- Torque wrench for 2.0 - 10 Nm
- Hose clamping pliers
- Metric thread-setter kit for M6 aluminum rivet nut
- Metric thread-setter kit for M10 steel rivet nut (e.g. Würth Order No. 0964948900)

Explanatory notes on document

To provide you with a quick overview of the individual working steps, you will find an identification mark on the outside top right corner of the page in question.

Mechanical system

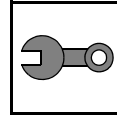

Electrical system

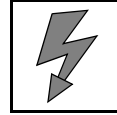

Coolant circuit

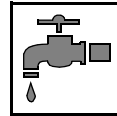

Fuel

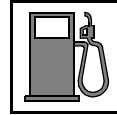

Exhaust gas

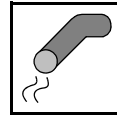

Combustion air

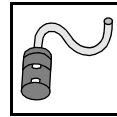

Special features are highlighted using the following symbols:



Specific risk of injury or fatal accidents.



Specific risk of damage to components.



Specific risk of fire or explosion.



Reference to general installation instructions of Webasto components or to the manufacturer's vehicle-specific documents.



Reference to a special technical feature.

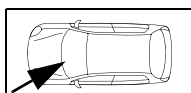
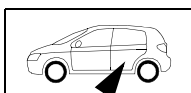

The arrow in the vehicle icon indicates the position on the vehicle and the viewing angle.

Preliminary work



Warning!

- Open the fuel tank cap and vent the fuel tank.
- Close the fuel tank cap again.
- Disconnect the battery earth connection.
- Depressurise the cooling system.
- Copy the factory number from the original type label to the duplicate type label.
- Remove years that do not apply from the duplicate label.
- Attach the duplicate label (type label) in the appropriate place.
- Remove the engine cover (if present).
- C-MAX only: remove the coolant reservoir trim completely at the top and bottom.
- Remove the underdrive protection (if present).
- Remove the underbody trim in front of the right rear wheel (no further use).
- Remove the fuel tank according to the manufacturer's instructions.
- Remove the glove compartment.
- Remove the A-pillar trim in the front passenger side footwell.
- Only with automatic air-conditioning: Remove the A/C control panel according to the manufacturer's specifications.

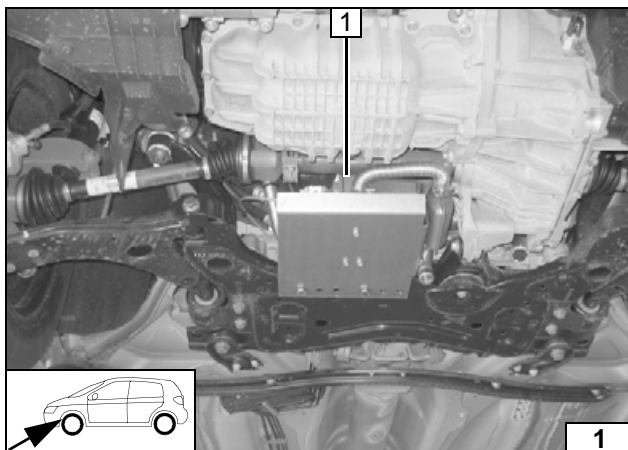

Heater installation location

Figure shows 1.8 lt engine

1 Heater



Installation location

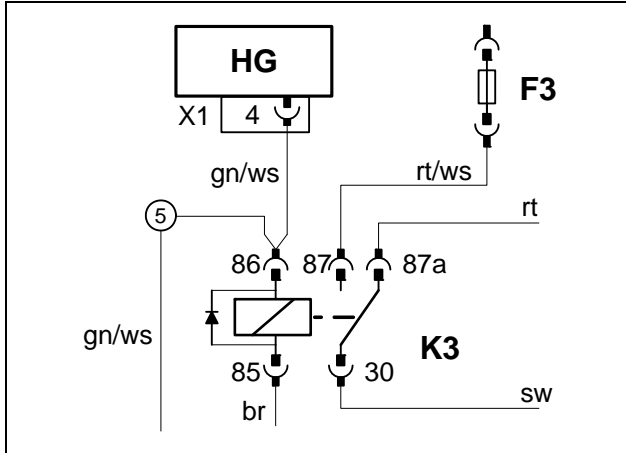

Preparing electrical system

Only with automatic air-conditioning

Connect additional green/white (gn/ws) wire 5 to K3/86 and pull into protective sleeving.



Wiring diagram for additional wire

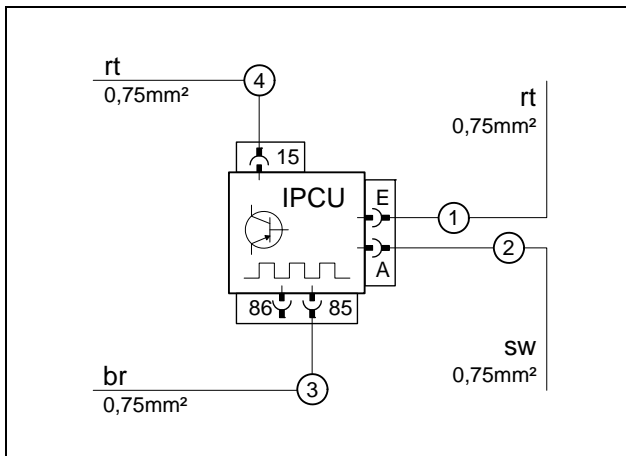

Connect provided wires to IPCU as shown in wiring diagram.

Connect 6 mm dia. cable lug to end of brown (br) wire from IPCU/85 3.



Premounting IPCU connection



Electrical system of Focus

Wiring harness pass through

- 1 Protective rubber plug detached

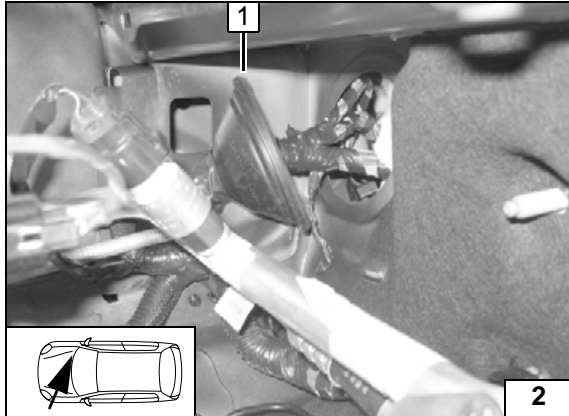

Digital timer

- 1 Digital timer
- 2 Summer/winter switch, drilled hole 12 mm dia.

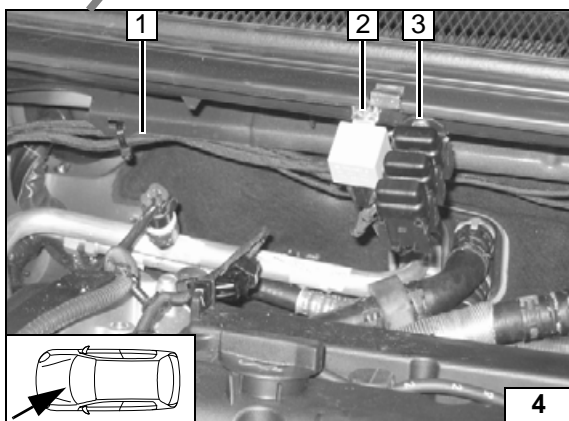
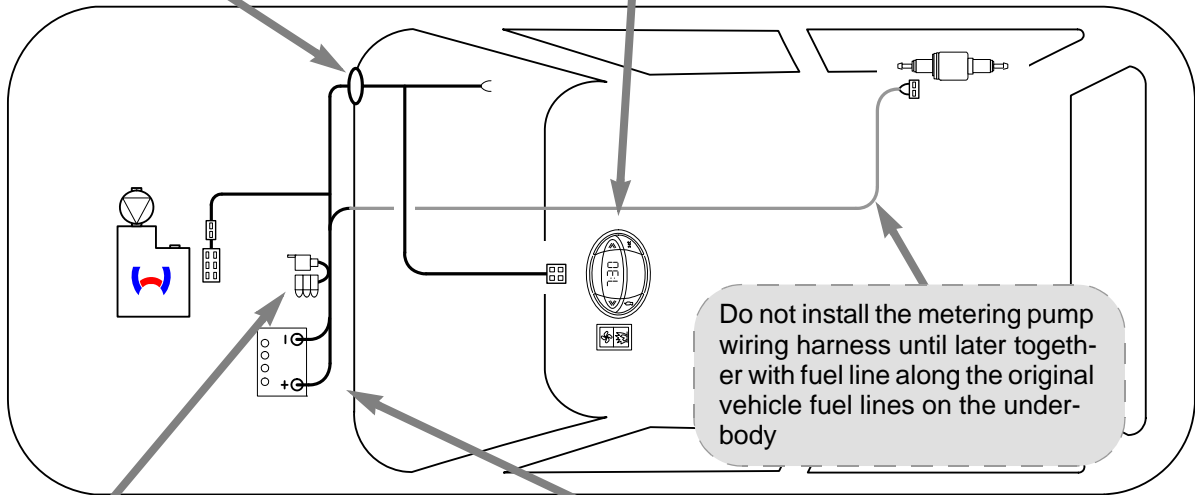
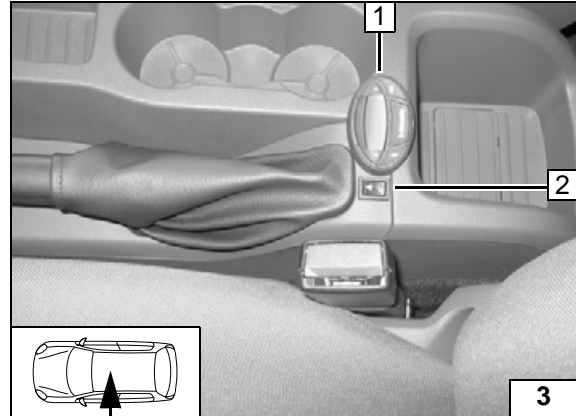

Fuse holder, K3 relay

When drilling, watch components located behind.

- 2 K3 relay, 4 mm dia. hole, 5.5x13 self-tapping screw
- 3 Fuse holder, 4 mm dia. hole, 5.5x13 mm self-tapping screw
- 1 Wiring harnesses routed to right and fastened with cable ties

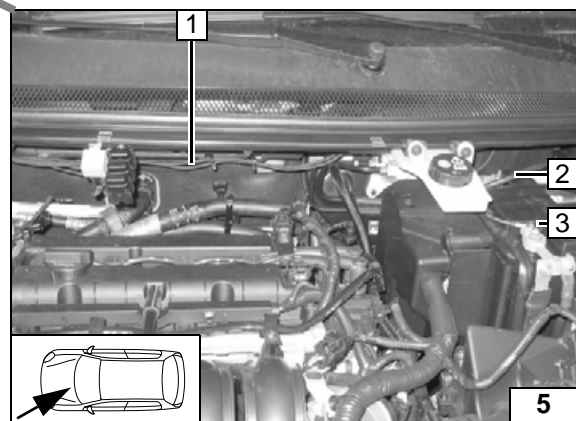

Connection to battery

Route wires (1) to left and fasten with cable ties.

- 2 Earth wire on negative battery terminal
- 3 Positive wire on positive battery terminal



Diagram of wiring harness routing for Focus





Electrical system for Focus/Focus CC from 2008

Wiring harness pass through

1 Protective rubber plug detached

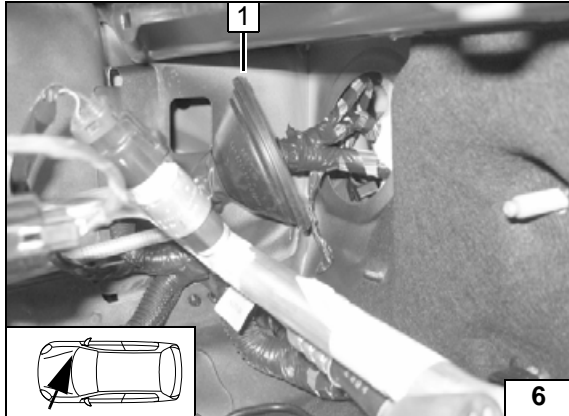

Digital timer

1 Digital timer

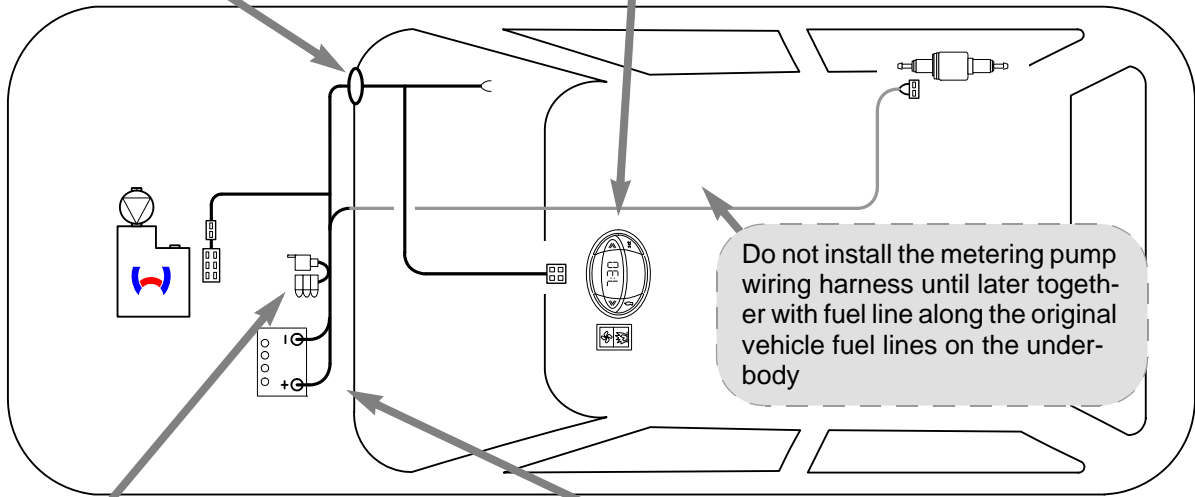
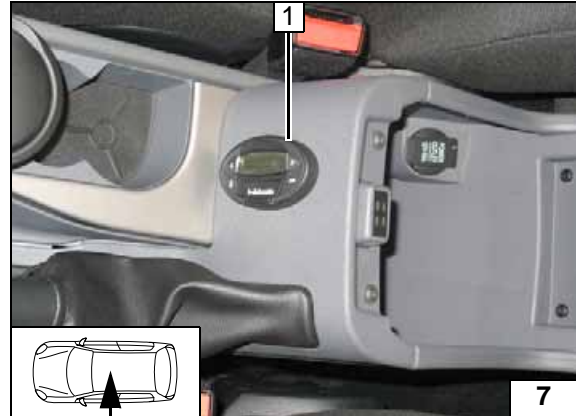
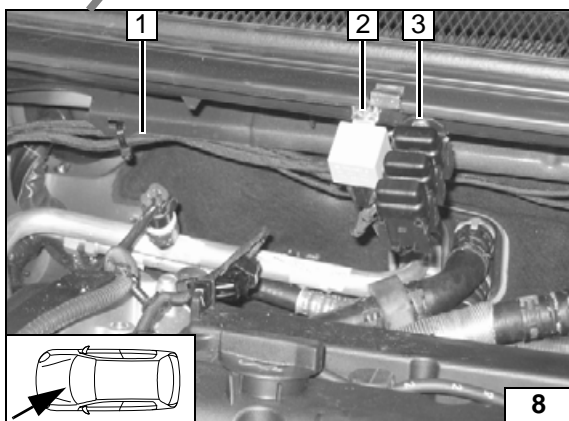

Diagram of wiring harness routing for Focus



Fuse holder, K3 relay

When drilling, watch components located behind.

- 2 K3 relay, 4 mm dia. hole, 5.5x13 self-tapping screw
- 3 Fuse holder, 4 mm dia. hole, 5.5x13 mm self-tapping screw
- 1 Wiring harnesses routed to right and fastened with cable ties

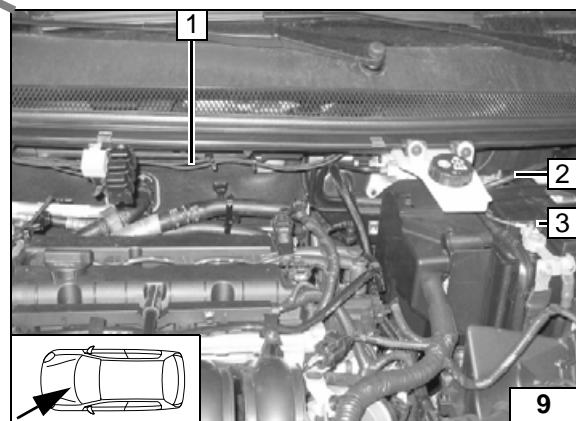

Connection to battery

Route wires (1) to left and fasten with cable ties.

- 2 Earth wire on negative battery terminal
- 3 Positive wire on positive battery terminal



Electrical system of C-Max

Wiring harness pass through

- 1 Protective rubber plug detached

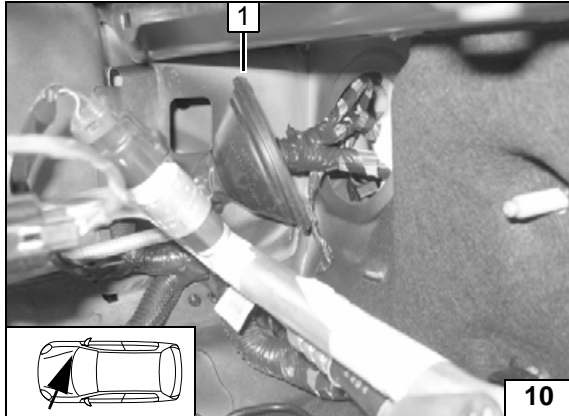

Digital timer

- 1 Digital timer
- 2 Summer/winter switch, drilled hole 12 mm dia.

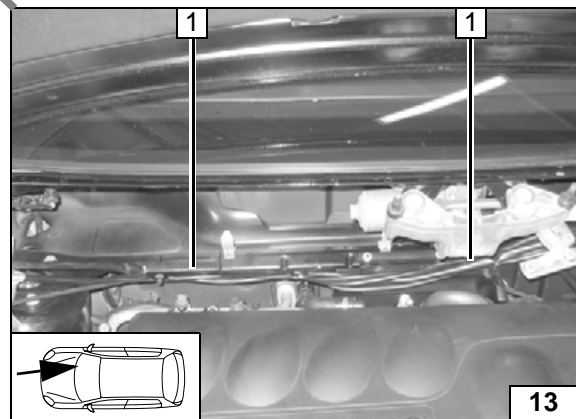
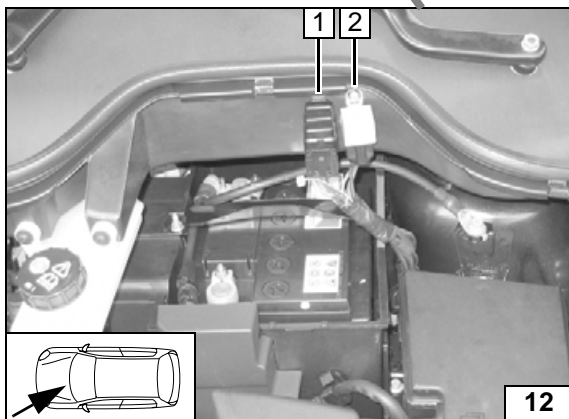
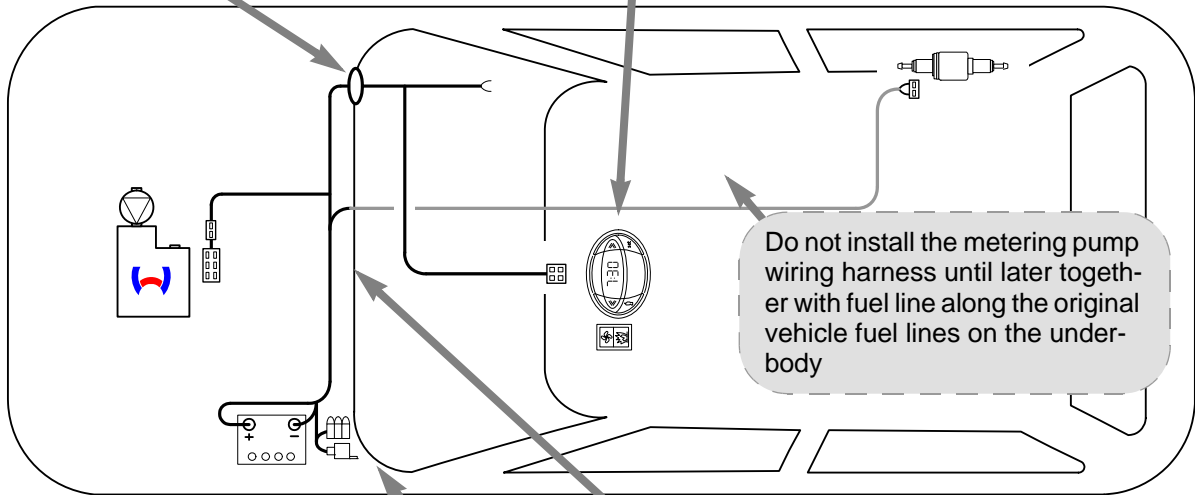
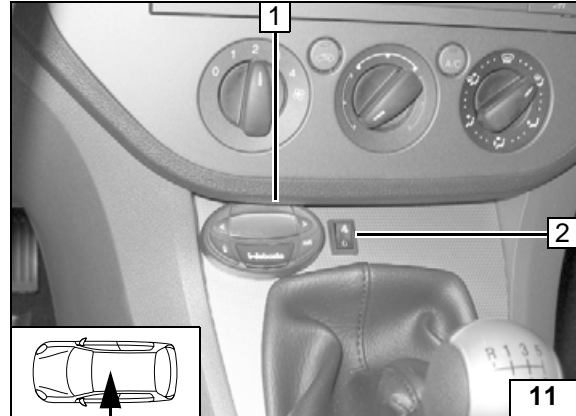

Fuse holder, K3 relay

Fastening will not be carried out until later after reinstalling the coolant reservoir cap. When drilling, watch components located behind.

- 1 Fuse holder, 4 mm dia. hole, 5.5x13 mm self-tapping screw
- 2 K3 relay, 4 mm dia. hole, 5.5x13 self-tapping screw

Wiring harness routing

Connect earth wire to negative battery pole and positive wire to positive battery pole.

Route wiring harness (1) to right and fasten with cable ties as shown.



Wiring harness routing diagram for C-Max



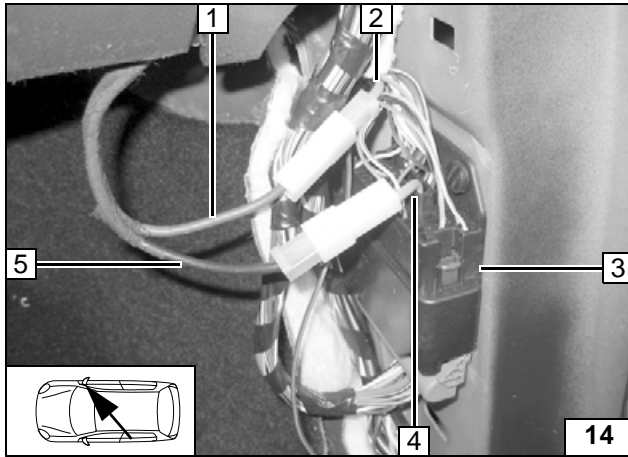

Fan control without automatic A/C

Connection is carried out on connector C111, Pin 22, at bottom of right-hand A-pillar. Produce connections as shown in wiring diagram with blade connectors provided.

- 3 Connector C111
- 1 Red (rt) wire to K3/87a
- 2 Green/orange (gn/or) wire from original vehicle fan relay K14
- 4 Wire to connector C111, Pin 22
- 5 Black (sw) wire from K3/30



**Connect-
ing fan
motor**



**Wiring dia-
gram with-
out
automatic
air-condi-
tioning**

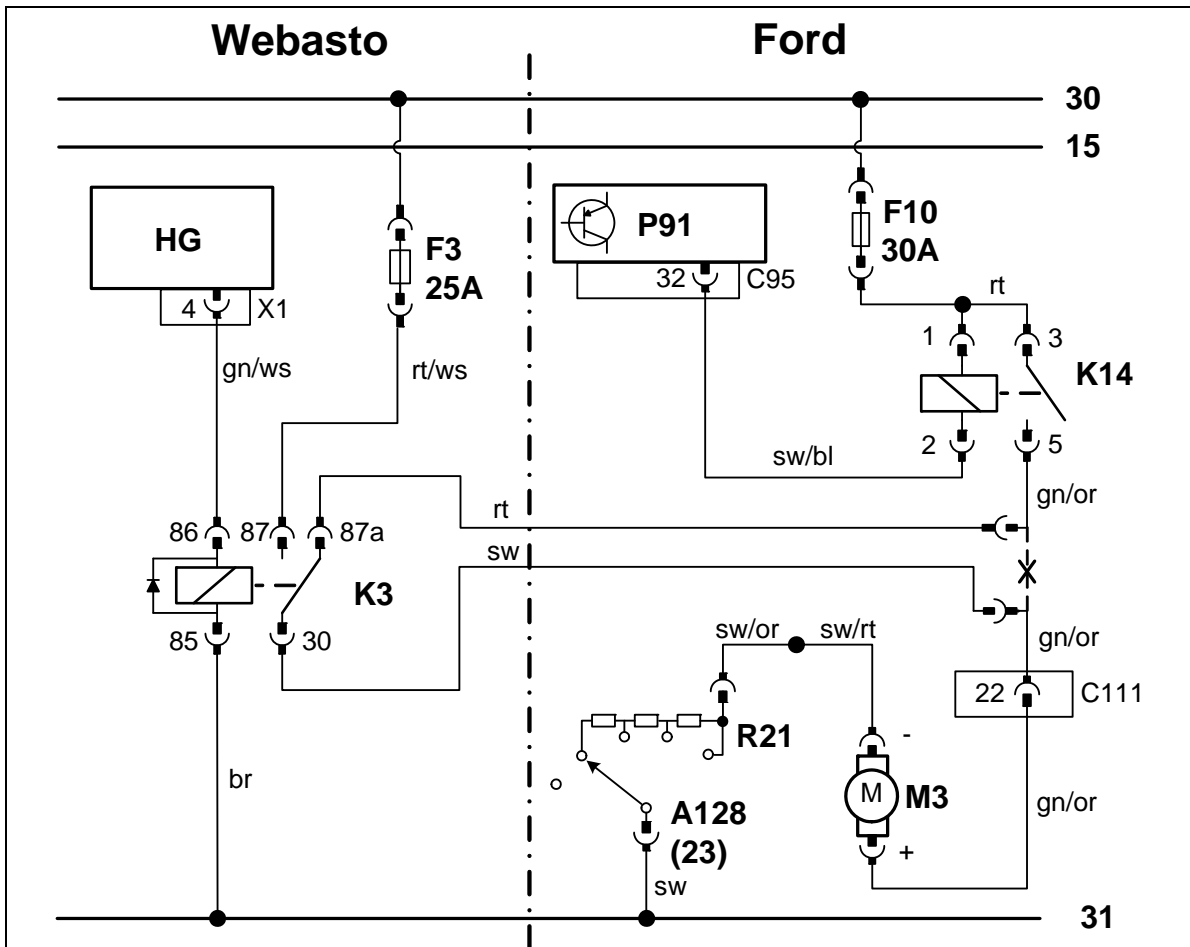

Webasto components		Ford components		Colours and symbols	
HG	Heater TT-E	F10	Fan fuse	rt	red
F3	Fan fuse	K14	Fan relay	ws	white
K3	Fan relay	P91	Central electrical box	sw	black
		C111	Connector on right-hand A-pillar	br	brown
		M3	Fan motor	gn	green
		R21	Resistor group	bl	blue
		A128	Heater control module	or	orange
		23	Fan switch		
				X	Cutting point

Legend

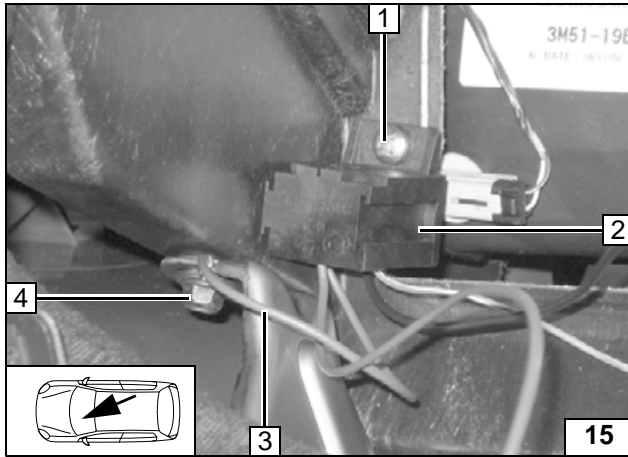

Automatic A/C fan control

- 2 IPCU socket
- 1 4 mm dia. hole, 5.5x13 self-tapping screw
- 3 Brown (br) wire from IPCU/85
- 4 6 mm dia. cable lug, original vehicle bolt

IPCU fastening

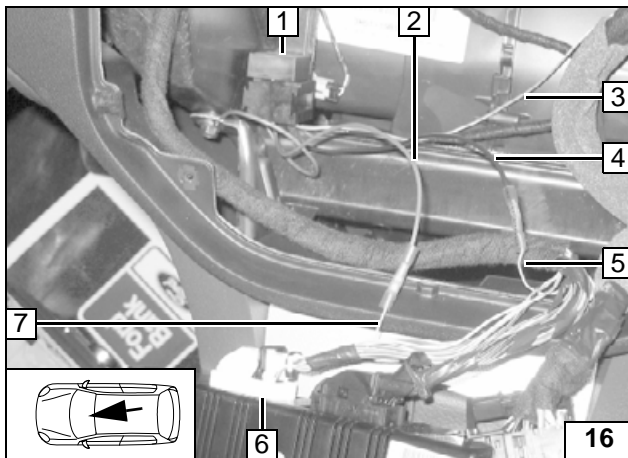

Connection is carried out on 26-pin connector C540, Pin 15.
Produce connections as shown in wiring diagram.

- 6 Connector C540
- 1 Connect IPCU
- 3 Green/white (gn/ws) wire from K3/86
- 4 Black (sw) wire from IPCU/A
- 5 Blue/white (bl/ws) wire to fan unit
- 7 Blue/white (bl/ws) wire from A/C control module
- 2 Red (rt) wire to IPCU/E

Connect-
ing air-
condition-
ing control
panel

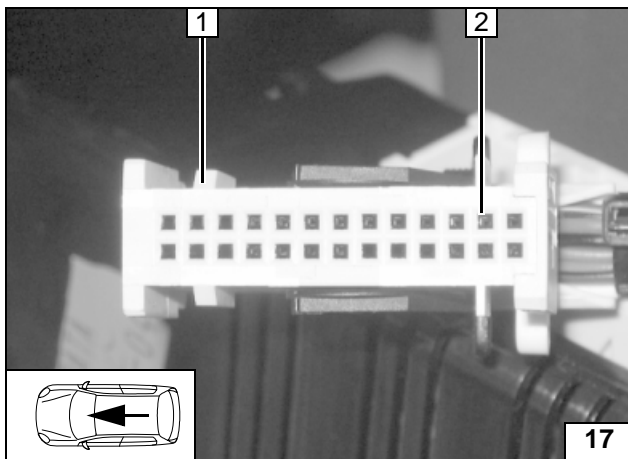

- 1 Connector C540
- 2 Pin 15

View of
connector

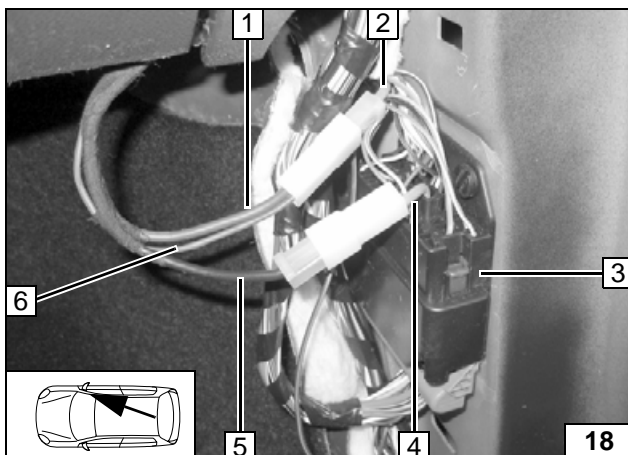

Connection is carried out on connector C111, Pin 22, at bottom of right-hand A-pillar.
Produce connections as shown in wiring diagram.
From 12/05, see page 12.

- 3 Connector C111
- 1 Red (rt) wire from K3/87a
- 6 Red (rt) wire from IPCU/15
- 2 Green/orange (gn/or) wire from original vehicle fan relay K14
- 4 Green/orange (gn/or) wire to connector C111, Pin 22
- 5 Black (sw) wire from K3/30 (on vehicles from 12/05, see page 12)

Connec-
tion to fan
unit

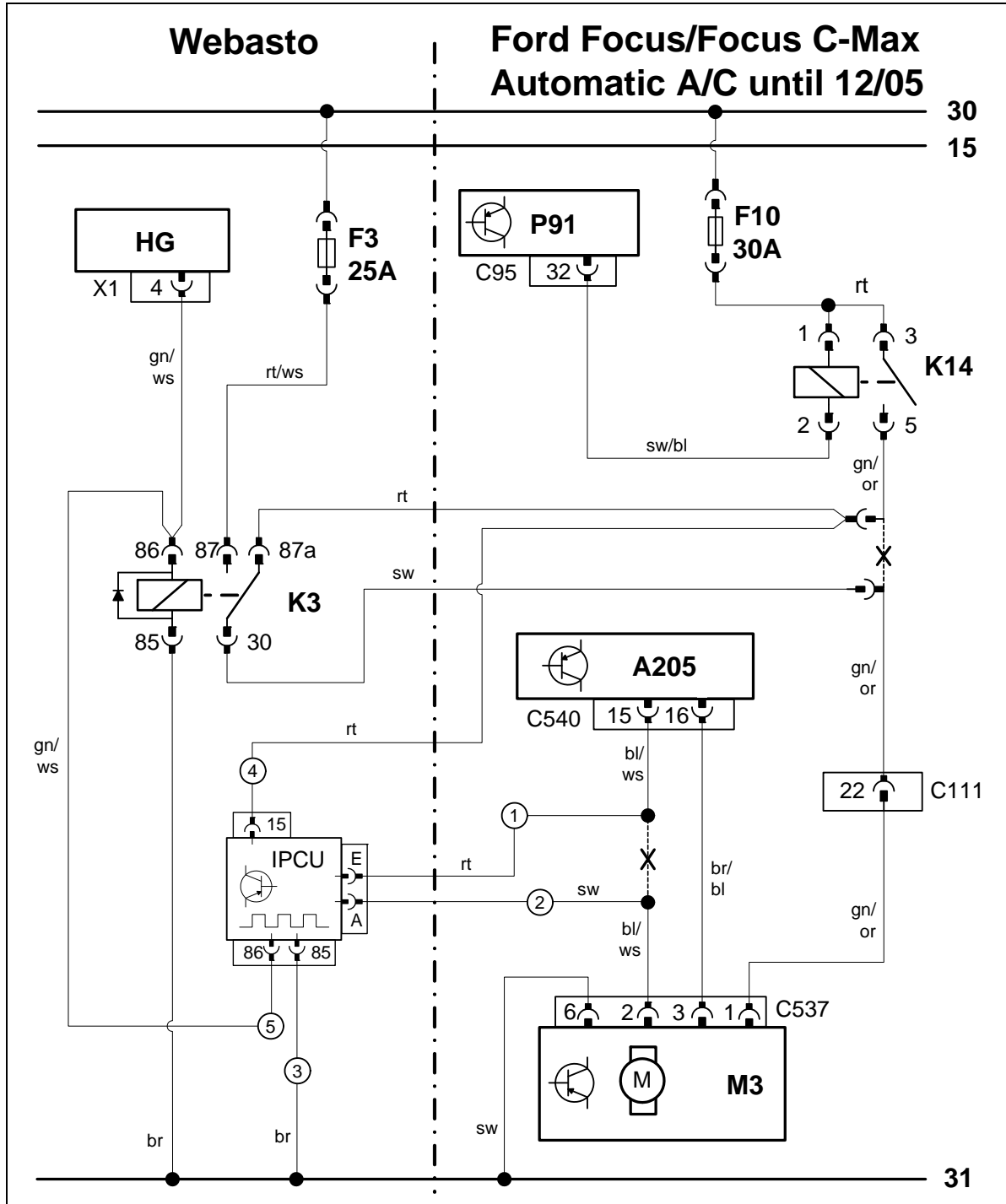

Wiring diagram for automatic air-conditioning

Webasto components		Vehicle components		Colours and symbols	
HG	Heater TT-E	F10	Fan fuse	rt	red
X1	Connector on heater	K14	Fan relay	ws	white
F3	Fan fuse	C111	Connector on right-hand A-pillar	sw	black
K3	Fan relay			br	brown
IPCUC	Pulse width modulator	P91	Central electrical box	gn	green
IPCUC settings:		C95	Connector on P91	bl	blue
Duty cycle: 60%		M3	Fan unit	or	orange
Frequency: 400Hz		C537	Connector on M3		
Voltage: 10V		A205	A/C control module (EATC)	X	Cutting point
Function: Low side		C540	Connector on A205	Wiring colours may vary.	

Legend

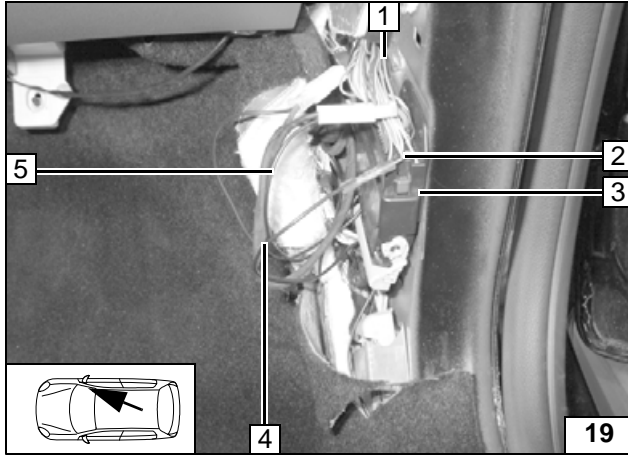

Additionally for automatic A/C from 01/06

Produce connections as shown in wiring diagram.

- 1 Cut off green/orange (gn/or) wire of C111/3 and insulate
- 2 Green/orange (gn/or) wire of C111/3
- 3 Connector C111
- 4 Black (sw) wire of F4
- 5 Black (sw) wire of F4

Fan controller

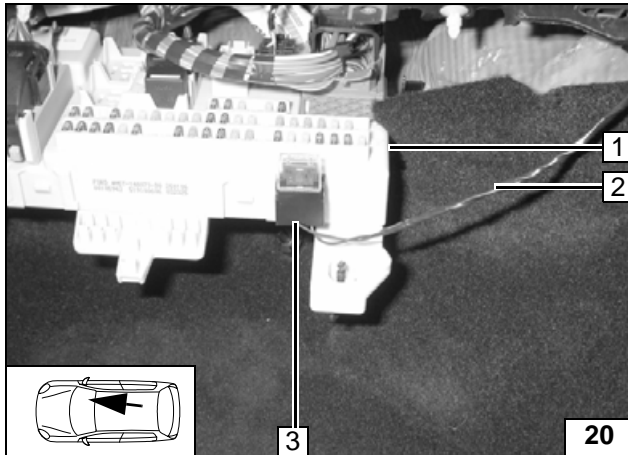

Complete fuse holder with materials provided and fasten it with double-sided adhesive tape.

Produce connections as shown in wiring diagram.

- 1 Central electrical box in right-hand footwell
- 2 Black (sw) wires, 500 mm
- 3 Fuse holder, 10 A fuse

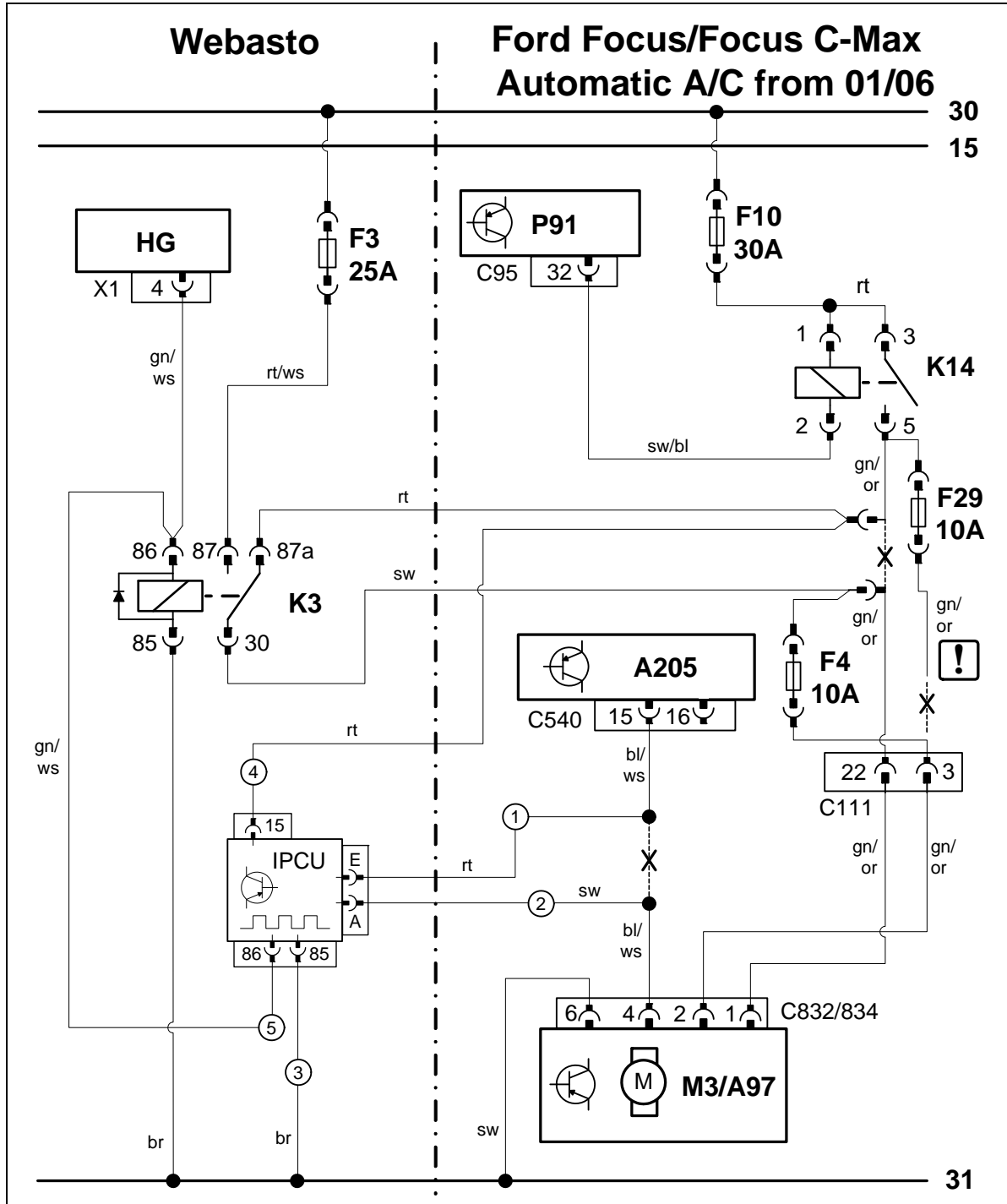

Fuse F4



Wiring diagram for automatic air-conditioning

Webasto components		Vehicle components		Colours and symbols	
HG	Heater TT-E	F10	Fan fuse	rt	red
X1	Connector on heater	K14	Fan relay	ws	white
F3	Fan fuse	C111	Connector on right-hand A-pillar	sw	black
K3	Fan relay			br	brown
IPCUC	Pulse width modulator	P91	Central electrical box	gn	green
IPCUC settings:		C95	Connector on P91	bl	blue
Duty cycle: 27%		M3	Fan unit	or	orange
Frequency: 400Hz		C537	Connector on M3		
Voltage: 10V		A205	A/C control module (EATC)	X	Cutting point
Function: Low side		C540	Connector on A205	Wiring colours may vary.	

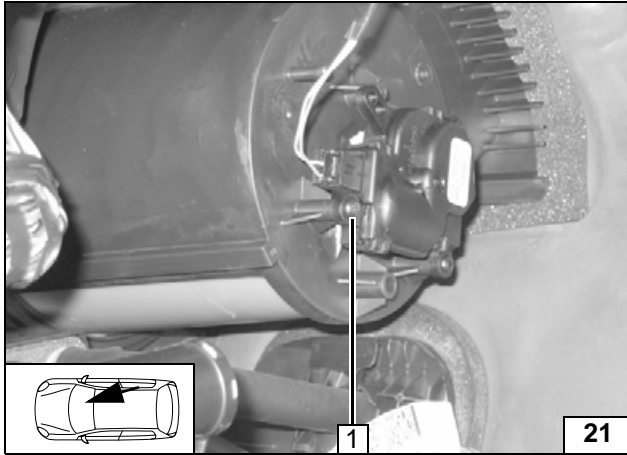
Legend



Remote option (Telestart)

Receiver is mounted on existing bolt on positioning motor.

- 1 Original vehicle bolt



Installation location of receiver

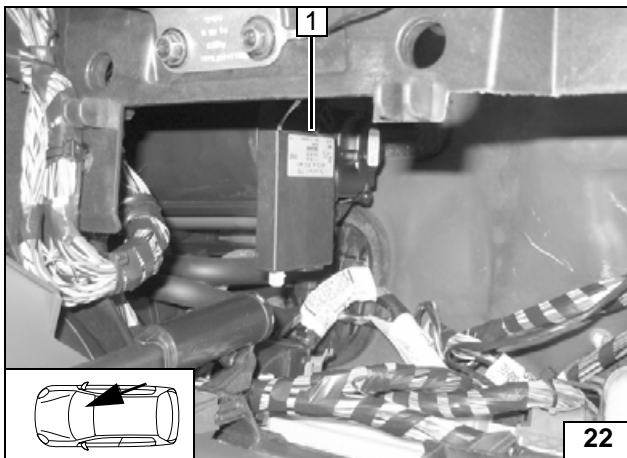

- 1 Receiver

Mounting receiver

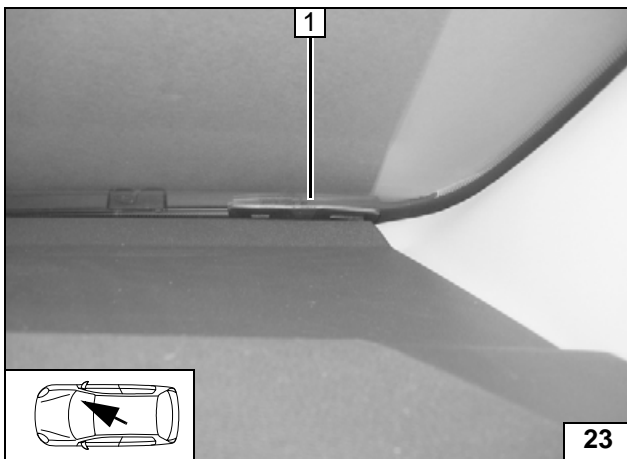

- 1 Antenna

Mounting antenna

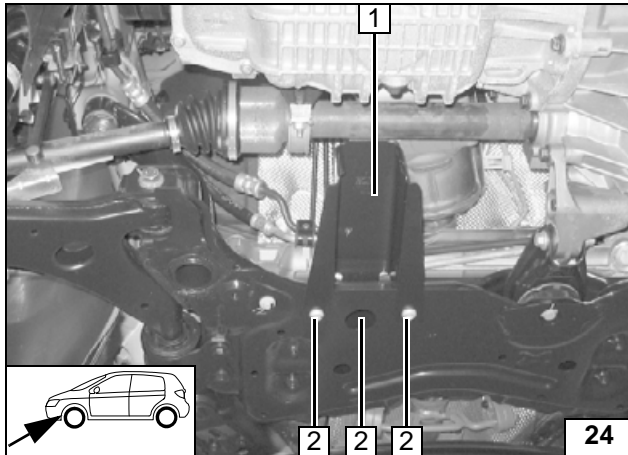
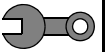

Preparing installation location

Cross member depends on vehicle equipment.

- 1 Cross member
- 2 M10 bolts [3x]



Removing cross member

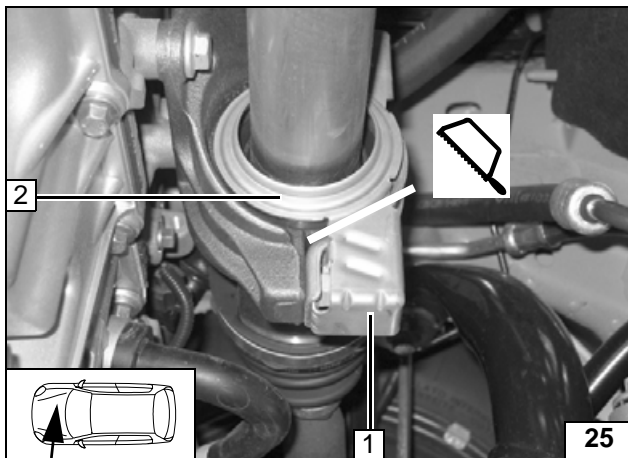

Design of guard plate (2) depends on the vehicle equipment

- 1 Remove section and discard



Adapting guard plate

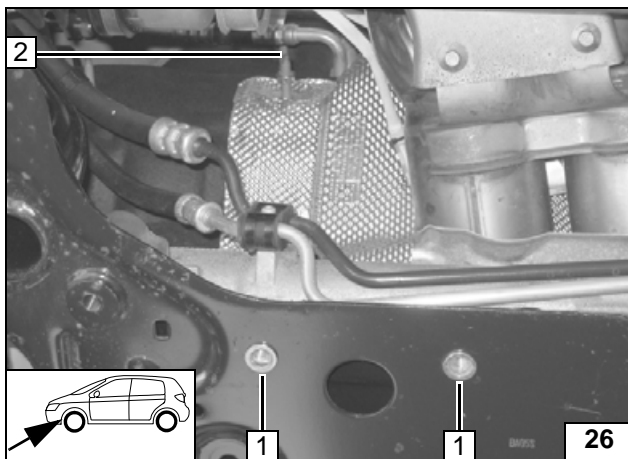

If threaded inserts are not present at position (1), then mount M10 rivet nuts provided in hexagonal holes.

Use special tool as shown on page 3.
For alternative, see next figure.

- 1 M10 steel rivet nut [2x]
- 2 Stud bolt



Installing rivet nuts

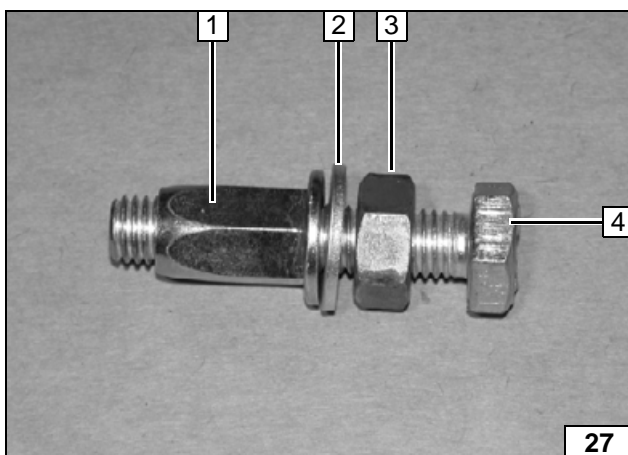

- 1 M10 rivet nut (steel)
- 2 Washer
- 3 M10 nut
- 4 M10 bolt



Alternative rivet-down tool

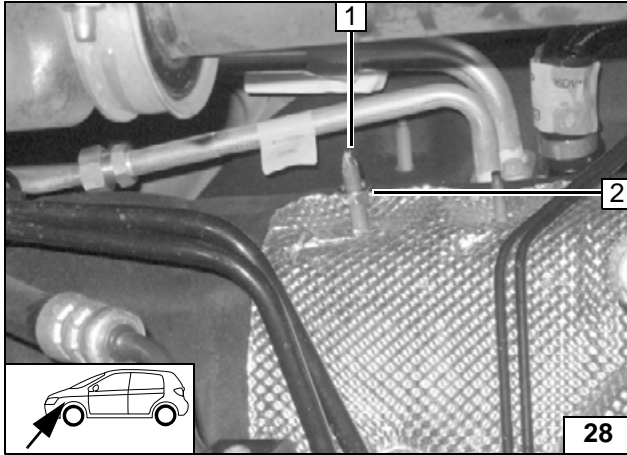
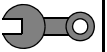

Screw on flanged nut with flange toward front.

- 1 Original vehicle stud bolt
- 2 M8 flanged nut



**Preparing
installa-
tion loca-
tion**

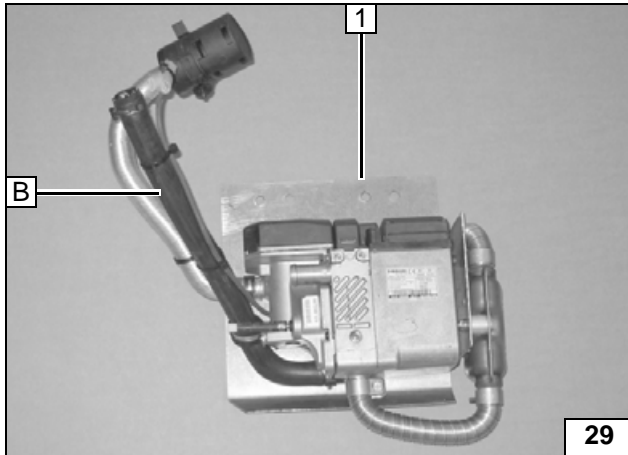
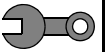

Premounting heater

1 Delivered heater assembly



Heater assembly

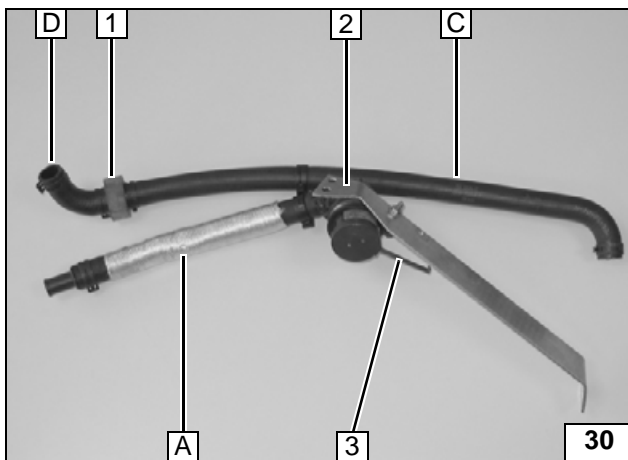

2 Delivered coolant assembly

- 1 Black (sw) rubber profile positioned in centre between spring clips
- 3 Remove connecting cable of circulating pump and discard



Coolant assembly

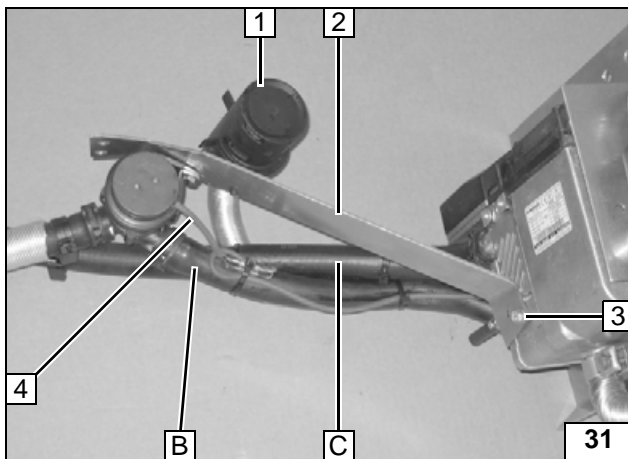

Hole in corner of strut is used at position 3. Mount Ejet screw 3 only loosely, so that strut 2 can still be aligned during installation. Connect wiring harness 4 to the circulating pump.



Connecting assemblies

1 Retaining clip with intake silencer engaged in hole

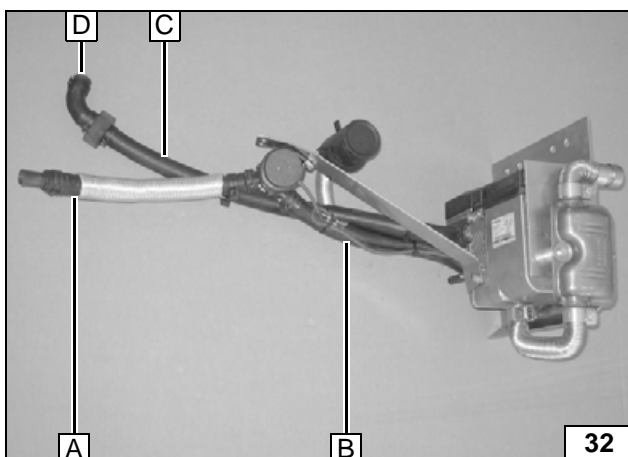

General view.

Fix hoses B and C and wiring harness of circulating pump in place with cable ties.



Connecting assemblies

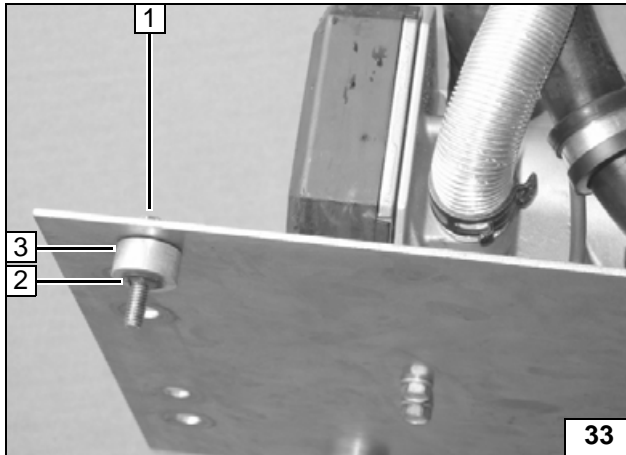
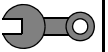

Fastening for underride protection

Vehicle-dependent, if present.

- 1 M6x25 bolt in existing 7 mm dia. hole
- 3 10 mm shim
- 2 Pin lock



Premounting heater

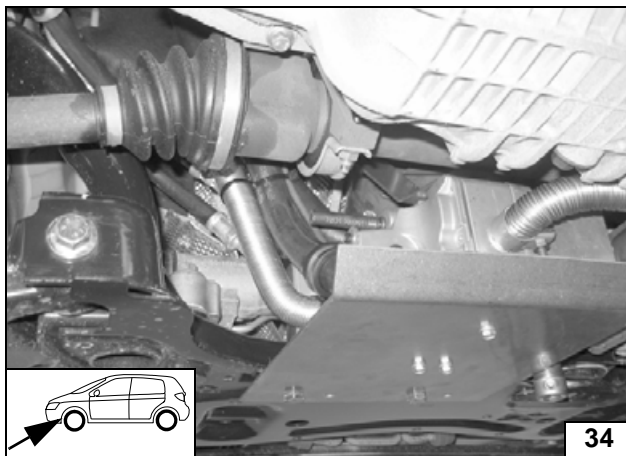

Installing heater

Only for 1.4 lt; 1.6 lt; 1.8 lt engine

Transport heater to installation location and connect wiring harness as shown.



Installing heater

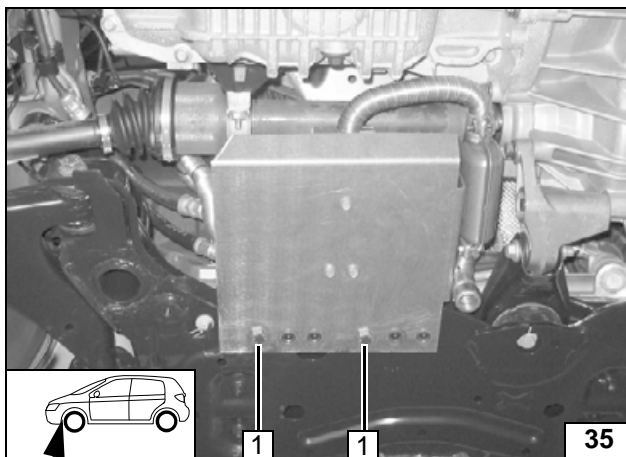

Use holes in bracket as shown. Check position of all components and adjust if necessary. Check that they have freedom of movement.

- 1 M10x30 bolt with locking tothing [2x]



Installing heater

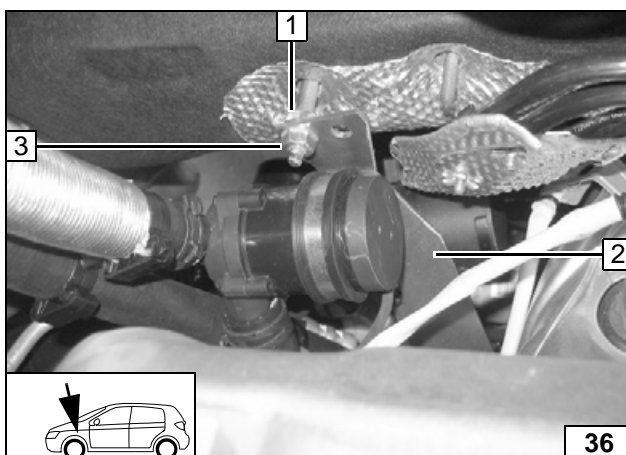

Use hole in strut as shown. Check position of all components and adjust if necessary. Check that they have freedom of movement.

- 1 M8 flanged nut (premounted)
- 3 Flanged nut
- 2 Strut



Mounting heater

Tighten Eجت screw (10 Nm).



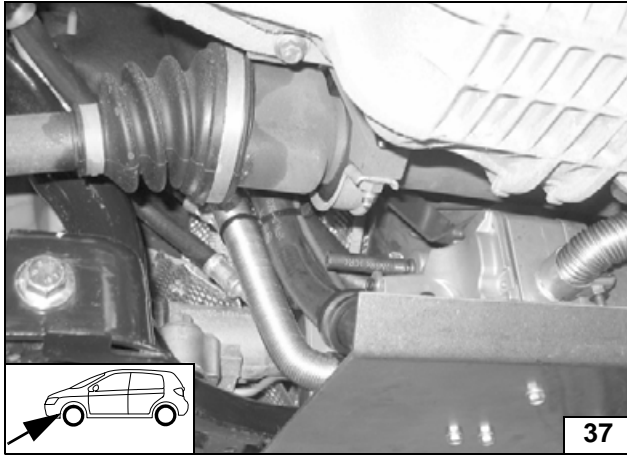
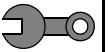

Only for 2.0 lt engine

Transport heater to installation location and connect wiring harness as shown.



Installing heater

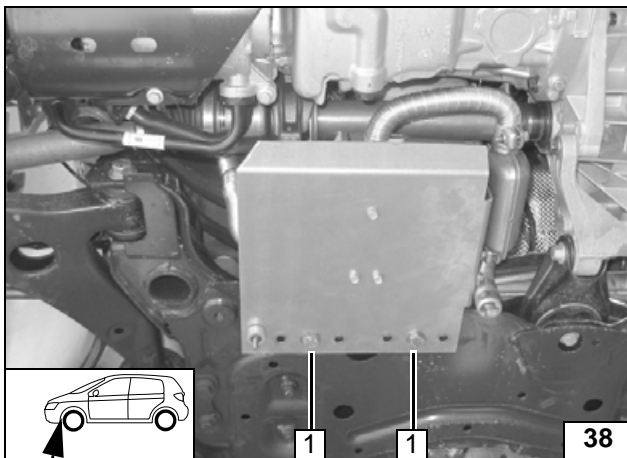

Use holes in bracket as shown. Check position of all components and adjust if necessary. Check that they have freedom of movement.

- 1 M10x30 bolt, spring lockwasher [2x]



Installing heater

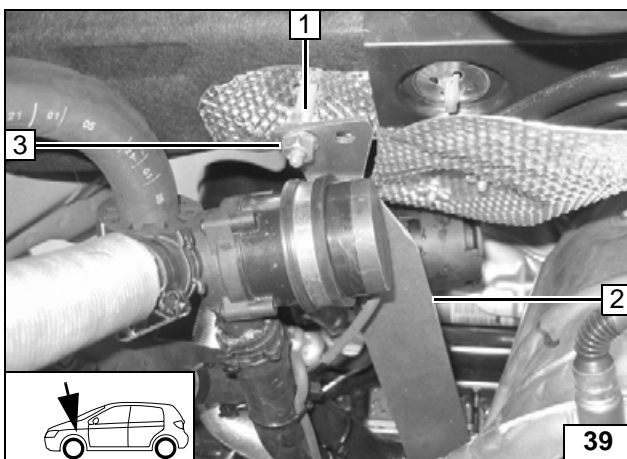

Use hole in strut as shown. Check position of all components and adjust if necessary. Check that they have freedom of movement.

- 1 M8 flanged nut (premounted)
- 3 Flanged nut
- 2 Strut



Mounting heater

Tighten Ejet screw (10 Nm).





Coolant circuit

WARNING!

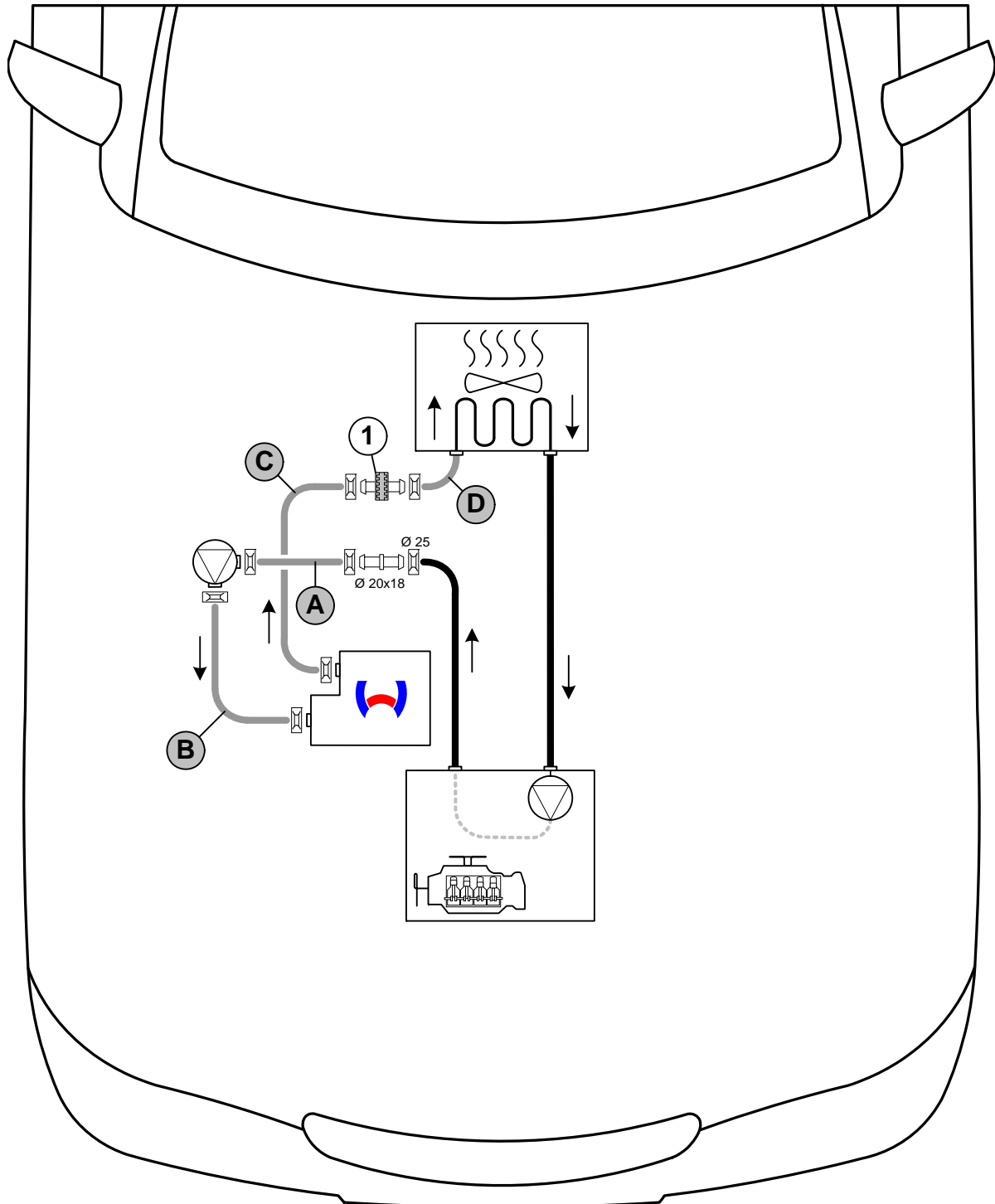

Any coolant running off should be collected in an appropriate container. Route hoses kink-free. Unless specified otherwise, always fasten using cable ties. Position clamps so that other hoses cannot be damaged. When installing the hoses, the heater must be filled with coolant.

The connection should be "inline" based on the following diagram:



Hose routing diagram

All spring clips without a specific designation  = 27 mm dia.

Undesignated connecting pipe  = 20x20mm dia. 1 = Black (sw) rubber isolator 

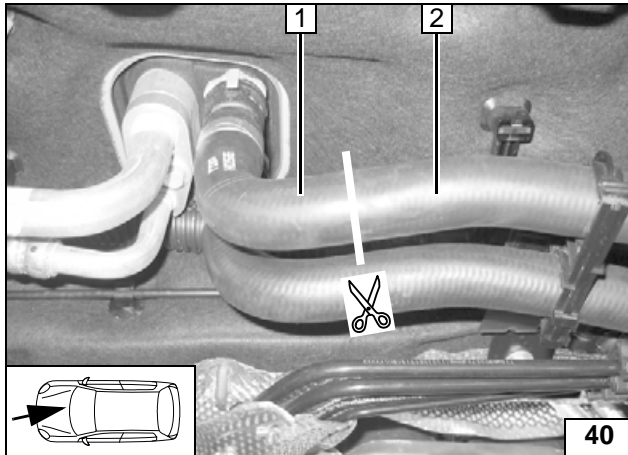

- 1 Hose section of heat exchanger inlet
- 2 Engine outlet hose section

Cutting point

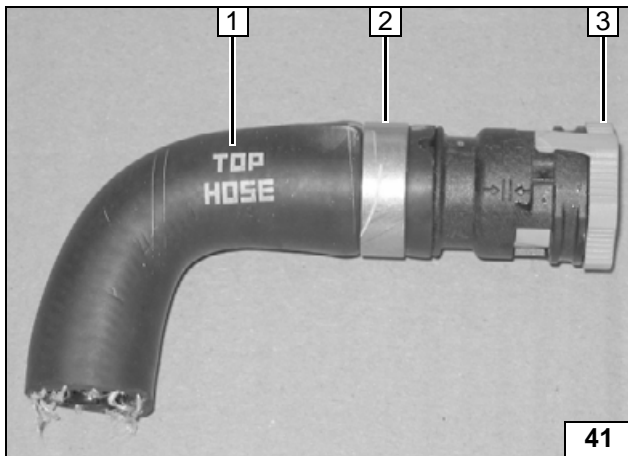

Remove connection piece according to manufacturer's instructions. Locking device (3) must be turned counterclockwise for this purpose.

- 2 Carefully saw open clamp
- 1 Discard hose



Preparing coolant

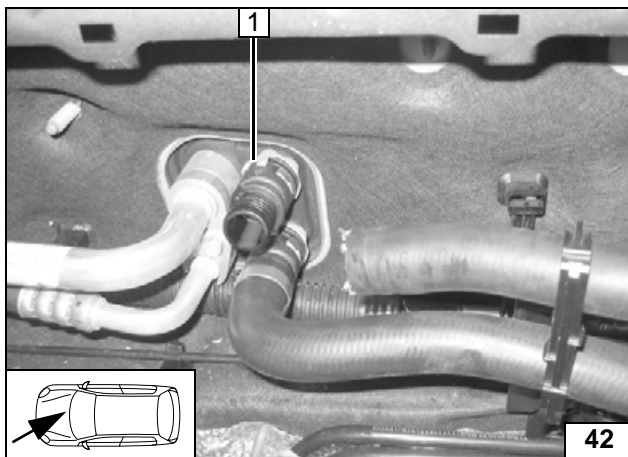

- 1 Connection piece of heat exchanger inlet mounted and locked

Preparing coolant

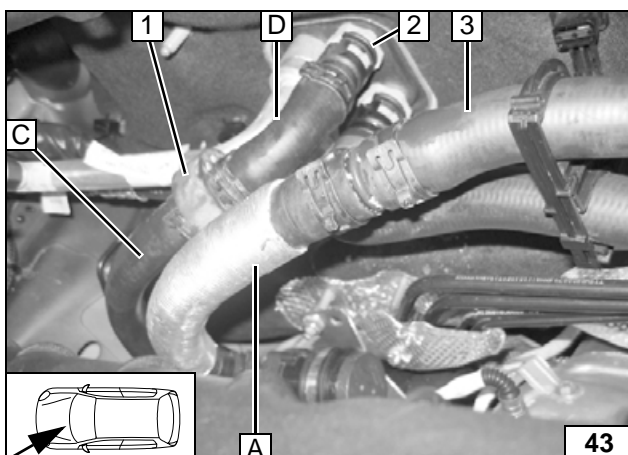

Before connecting, fill the coolant hoses with coolant.

- 1 Black (sw) rubber isolator between hose C and D
- 2 Connection piece of heat exchanger inlet
- 3 Engine outlet hose section

Connecting hoses

Check routing of hoses and correct if necessary. Fasten wiring harness of heater to coolant hoses with cable tie.





Fuel

CAUTION!

Open the vehicle's fuel tank cap, ventilate the tank and then re-close the tank lock.

Collect any discharged fuel in an appropriate container.

Install fuel line and metering pump wiring harness so that they are protected against stone impact. Unless specified otherwise, always fasten using cable ties.

Mount the fuel line and wiring harness with rub protection on sharp edges.

WARNING!

The fuel line and wiring harness of the metering pump are routed as shown in the wiring harness routing diagram.

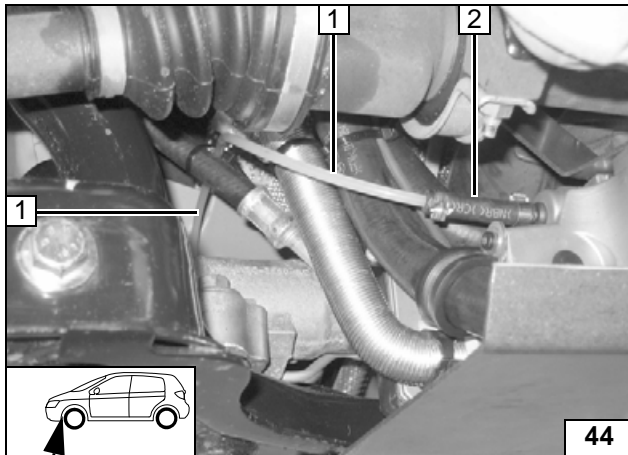

- 1 Mecanyl fuel line
- 2 10 mm dia. Caillau clamp

Route mecanyl fuel line to firewall and fasten with cable ties as shown. Pay particular attention to sufficient distance from cardan shaft.

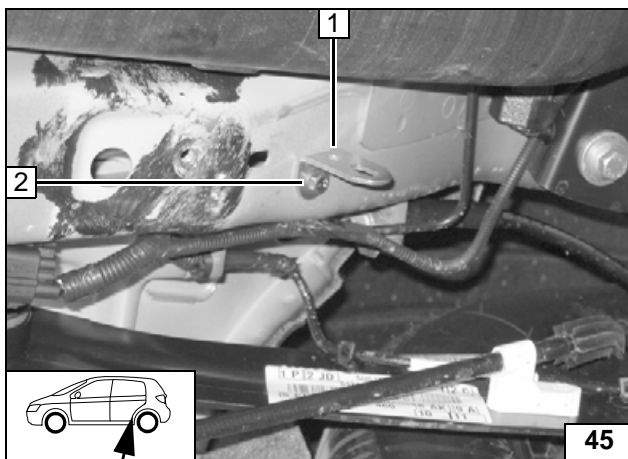

Installation location on right next to vehicle fuel tank.

- 1 Angle bracket
- 2 M6x20 bolt, spring lockwasher on existing threaded insert

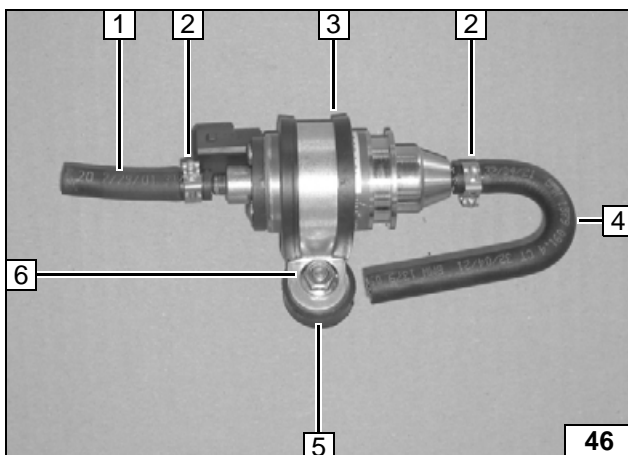

- 1 Hose section
- 2 10 mm dia. Caillau clamp [2x]
- 4 180° moulded hose
- 3 Rubber-coated p-clamp
- 5 Silent block
- 6 Flanged nut



Conne-
ction to
heater



Installa-
tion loca-
tion of
metering
pump

Premount-
ing meter-
ing pump

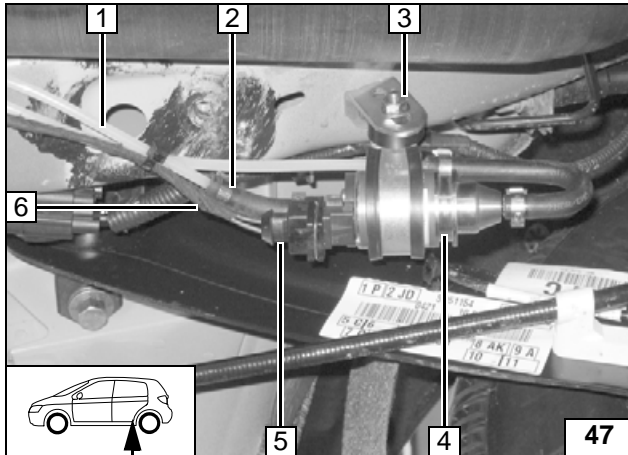

Slide metering pump as far as possible upward in oblong hole.
Route fuel line and wiring harness as shown in following illustration.
Fuel line to heater on pressure side of metering pump [side with connector].

- 4 Premounted metering pump
- 3 Flanged nut
- 1 Mecanyl fuel line
- 2 10 mm dia. Caillau clamp
- 6 Metering pump wiring harness
- 5 Completed connector housing

Mounting metering pump

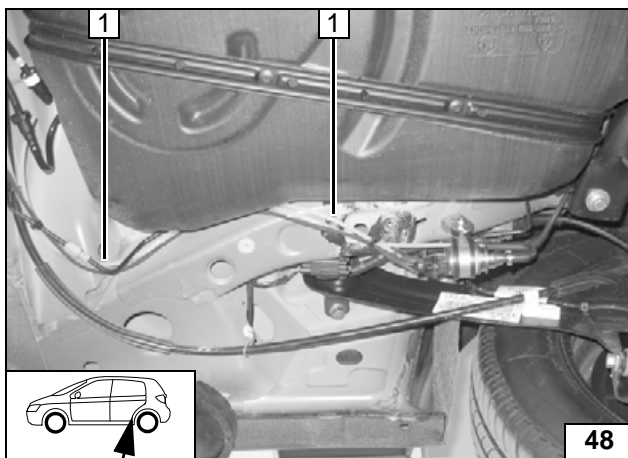

- 1 Mecanyl fuel line and metering pump wiring harness

Wiring routing

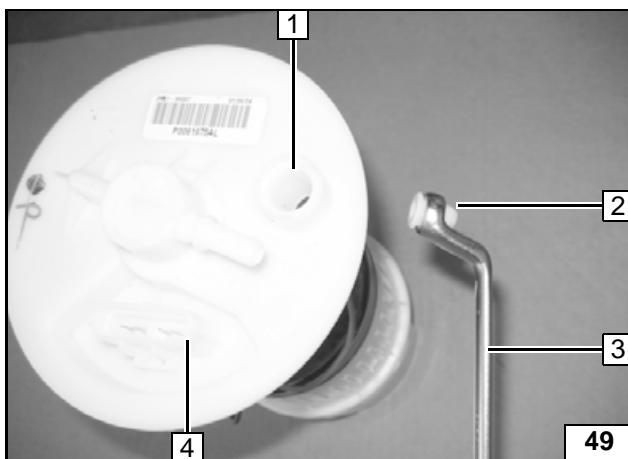

Removing fuel

Remove fuel-tank sending unit (4) in accordance with manufacturer's instructions.
Break out connection piece (2) at rupture joint (1) with suitable tool (3) according to manufacturer's instructions.



Fuel removal

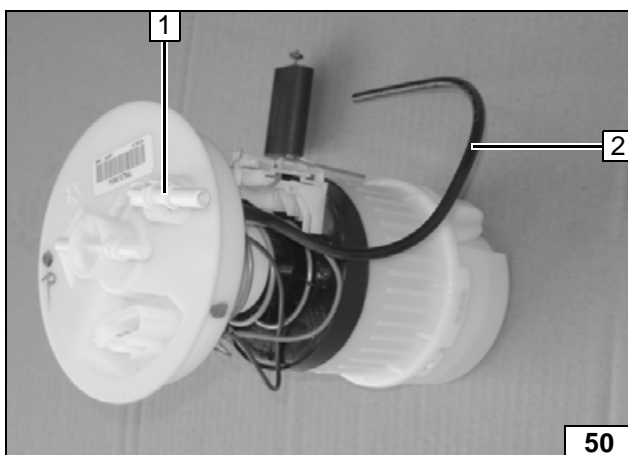

Install fuel standpipe (Ford Order No. Finis Code 1233999) according to manufacturer's instructions.

- 1 Fuel standpipe
- 2 Removal hose

Installing fuel standpipe



Align removal hose up to bottom of fuel tank. Ensure freedom of movement of fuel gauge.



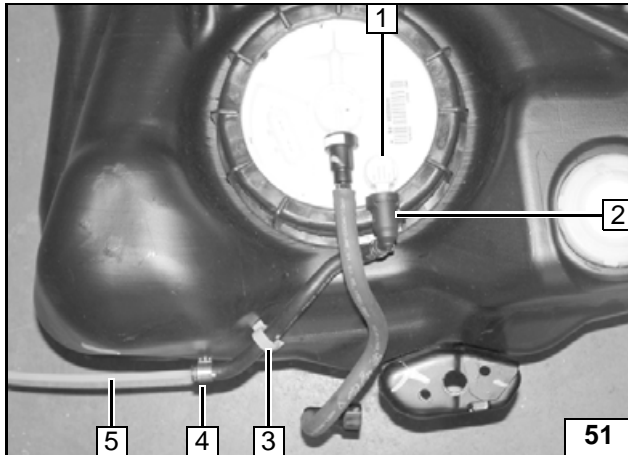

Install fuel-tank sending unit according to manufacturer's instructions. Mount coupling and align; remove clip at Position 3.

- 1 Fuel standpipe
- 2 Coupling piece, mounted on fuel standpipe
- 5 Mecanyl fuel line
- 4 10 mm dia. Caillau clamp
- 3 Clip

Reinstall fuel tank.

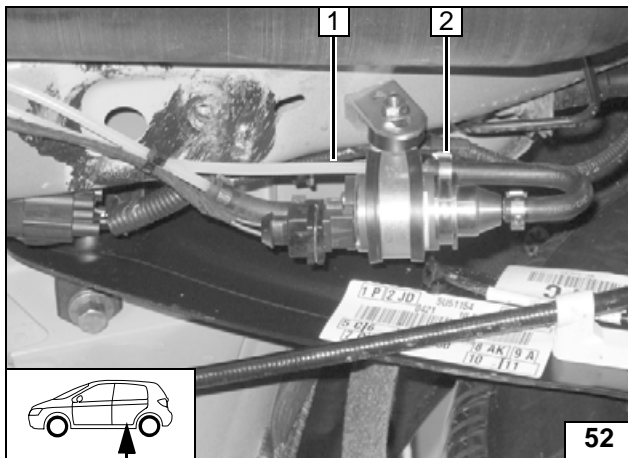

Fuel line from fuel standpipe on intake side of metering pump [side without connector].

- 1 Fuel line
- 2 10 mm dia. Caillau clamp

Check the position of the components; adjust if necessary. Check that they have freedom of movement.

Align fuel lines and wiring harness of metering pump over entire length and secure with cable ties.



**Connect-
ing fuel
line**



**Conne-
ction to me-
tering
pump**



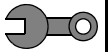

53

Mounting underdrive protection

For all vehicles!

Underdrive protection is dependent on vehicle equipment.

Cut out underdrive protection as shown.



Cutting out underdrive protection

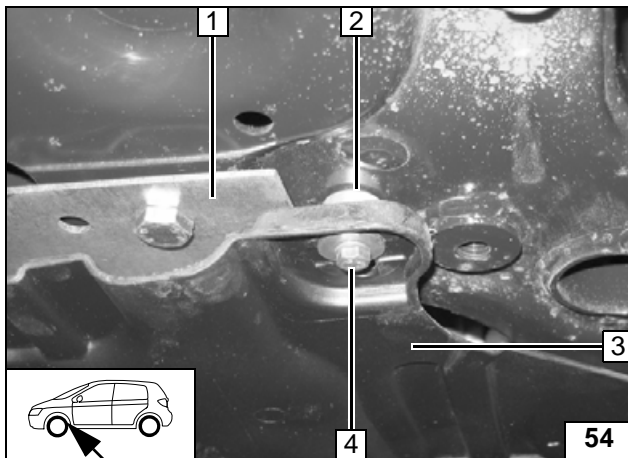

54

Only for 1.4 lt; 1.6 lt; 1.8 lt engine

Remove plastic threaded insert.

Drill out hole to 9 mm dia. and insert M6 rivet nut.

- 1 Bracket of heater
- 2 M6 rivet nut, 10 mm shim
- 3 Underdrive protection
- 4 M6x40 bolt, spring lock washer, large diameter washer



Mounting underdrive protection for 1.4 lt; 1.6 lt; 1.8 lt engine

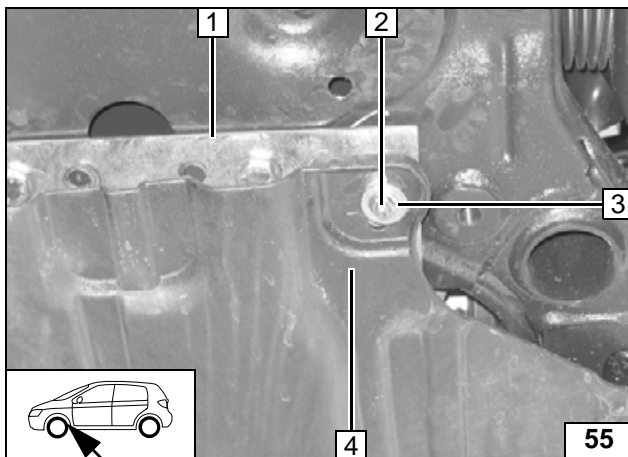

55

Only for 2.0 lt engine.

- 1 Bracket of heater
- 2 Pre-mounted bolt
- 4 Underdrive protection
- 3 M6 flanged nut, large diameter washer



Mounting underdrive protection for 2.0 lt engine

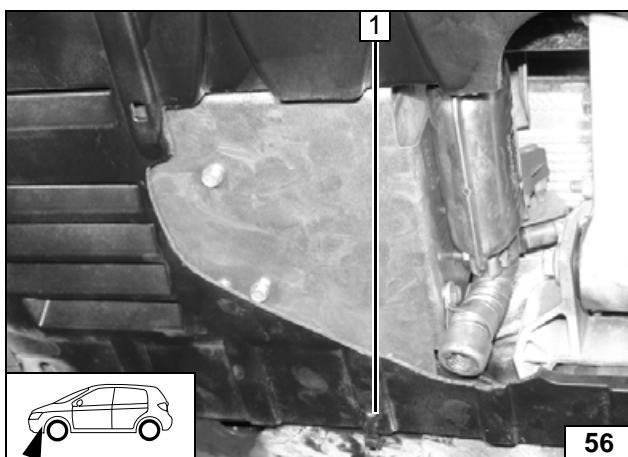

56

For all vehicles!

Figure shows 1.8 lt engine

Check positioning of underdrive protection. In particular, ensure sufficient distance from heater exhaust system. Rework cut-out if necessary.

Also fasten underdrive protection for stabilization with cable ties at position (1).



Mounting underdrive protection for all vehicles

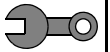

Final Work

WARNING!

Mount removed parts in reverse order. Check all hoses, clamps and all electrical connections for firm seating. Insulate and tie back all loose wires.

Only use manufacturer-approved coolant. Spray heater components with anti-corrosion wax (Tectyl 100K, Order No. 111329).

- **Connect the battery.**
- **Fill and bleed the coolant circuit according to the vehicle manufacturer's specifications.**
- **Adjust digital timer, teach Telestart sender**
- **Make settings on A/C control panel according to the "Operating Instructions for End Customer".**
- **Place signboard "Switch off parking heater before refuelling" in the area of the filler neck**
- **See installation instructions for initial startup and function check**



Webasto AG
Postfach 80
D-82132 Stockdorf / Germany
National Hotline: 01805 93 22 78
(14 Cent aus dem deutschen Festnetz)
Hotfax: 0395 5592 353
Hotmail: technikcenter@webasto.com
<http://www.webasto.com>

Operating instructions for end customer

Please remove page and add to the vehicle operating instructions.

WARNING:

On vehicles with "Flexyfuel" engine, operation of parking heater is only permissible with petrol.

Note:

We recommend matching the heating time to the driving time.

Heating time = driving time

Example:

For a driving time of approx. 20 min. (in one direction), we recommend not exceeding a switch-on time of 20 min.

Before parking the vehicle, make the following settings:

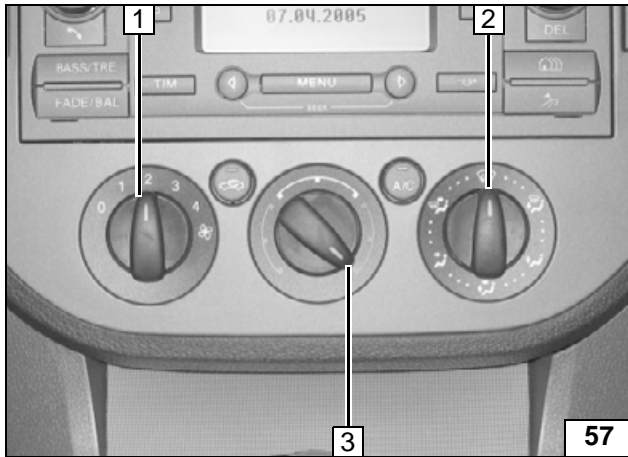

- 1 Set fan to level "2", or possibly "1"
- 2 Air outlet to windscreen
- 3 Set temperature to "max."

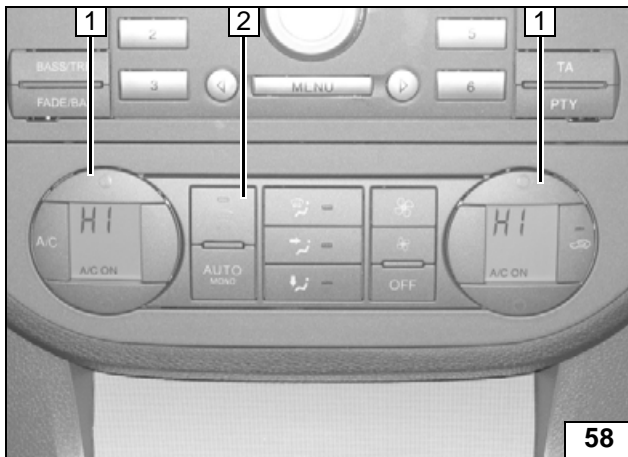

- 1 Temperature to "max." [2x]
- 2 Air outlet to windscreen



- 1 Temperature to "max." [2x]
- 2 Air outlet to windscreen



For vehicles without automatic air-conditioning

For vehicles with automatic air-conditioning

For vehicles with automatic air-conditioning