

# Water heater



Feel the drive

**Thermo Top E Parking Heater**

  
00 0003

**Thermo Top C Parking Heater**

  
00 0002

## Installation documentation

### Suzuki Grand Vitara

Diesel

Model 2006 up to 2010

VIN JSA JT A 44 V 00 500001 - 610000

JSA JT D 44 V 00 500001 - 610000

For left-hand drive vehicles only

Automatic air-conditioning



#### **WARNING!**

Hazard warning:

Incorrect installation or repair of Webasto heating systems may cause a fire or result in the emission of carbon monoxide, which can be fatal. Serious or fatal injuries can be caused as a result.



Specialist company training, technical documentation, specialised tools and equipment are required to install and repair Webasto heating and cooling systems.

Only original Webasto parts must be used. For this, also see the catalog of air and water heater accessories from Webasto.

**NEVER attempt to install or repair Webasto heating or cooling systems if you have not successfully completed the company training and thereby acquired the required technical skills, or if you do not have access to the required technical documentation, tools and equipment needed to carry out correct installation and repairs.**

ALWAYS follow all Webasto installation and repair instructions and observe all warnings.

**The initial startup is to be executed with the Webasto Thermo Test Diagnosis.**

Webasto does not accept any liability for defects and damage that are attributable to installation by untrained staff.

## Table of Contents

|                                 |    |   |    |
|---------------------------------|----|---|----|
| Validity                        | 2  | Preparing heater                        | 13 |
| Heater / delivery scope         | 3  | Installing heater                       | 14 |
| Foreword                        | 3  | Coolant circuit                         | 15 |
| General Instructions            | 3  | Fuel                                    | 18 |
| Special Tools                   | 3  | Exhaust gas                             | 20 |
| Explanatory Notes on Document   | 4  | Final Work                              | 21 |
| Preliminary Work                | 5  | Operating Instructions for End Customer | 22 |
| Heater installation location    | 5  |   |    |
| Preparing electrical system     | 6  |   |    |
| Electrical system               | 7  |   |    |
| Fan control                     | 8  |   |    |
| Digital timer                   | 10 |   |    |
| Summer/winter switch option     | 10 |   |    |
| Remote option (Telestart)       | 10 |   |    |
| Preparing installation location | 12 |   |    |

## Validity

| Manufacturer | Model        | Type | EG BE No. / ABE              |
|--------------|--------------|------|------------------------------|
| Suzuki       | Grand Vitara | JT   | e4 * 2001 / 116 * 0091 * ... |

| Engine type | Engine model | Output in kW | Displacement in cm <sup>3</sup> |
|-------------|--------------|--------------|---------------------------------|
| F9Q         | Diesel       | 95           | 1870                            |

Vehicle and engine types, equipment variants and national specifications not listed in this installation documentation have not been tested. However, installation according to this installation documentation may be possible.

The installation location of a digital timer and summer/winter switch should be confirmed with the end customer before installation.

# Suzuki Grand Vitara

## Heater / delivery scope

| Quantity | Description                           | Order No.:            |
|----------|---------------------------------------|-----------------------|
| 1        | Suzuki-specific heater delivery scope | See Suzuki price list |

## Required additionally:

| Quantity | Description   | Order No.: |
|----------|---|------------|
| 1        | Installation set of Suzuki Grand Vitara Diesel from Model Year 06 | 1310827A   |

## Optional heater control either:

| Description     | Order No.:            |
|-----------------|-----------------------|
| Heater controls | See Suzuki price list |

## Heater recommended for the respective vehicle class:

| Vehicle                     | Heater       |
|-----------------------------|--------------|
| Compact car                 | Thermo Top E |
| Mid-size car, station wagon | Thermo Top C |

The selection of the heater is based on the passenger compartment size of the vehicle and the level of comfort required by the customer!



## Foreword

This installation documentation applies to Suzuki Grand Vitara vehicles with a Diesel engine - for validity, see page 2 - from model year 2006 up to 2010 and later, assuming technical modifications to the vehicle do not affect installation, any liability claims excluded. Depending on the vehicle version and equipment, modifications may be necessary during installation with respect to the installation documentation.

However, the stipulations in this "installation documentation", the "operating instructions" and the "Installation instructions" for the **Thermo Top C/E** must always be observed.

The corresponding rules of technology and any information from the vehicle manufacturer should be observed during the installation work.

## General Instructions

Installation should be carried out according to the general, standard rules of technology. Unless specified otherwise, fasten hoses, lines and wiring harnesses to original vehicle lines and wiring harnesses using cable ties.

Sharp edges should be fitted with rub protection (split-open plastic hose).

Spray unfinished body areas, e.g. drilled holes, with anti-corrosion wax (Tectyl 100K, Order No. 111329).

## Special Tools

- Torque wrench for 2.0 - 10 Nm
- Hose clamping pliers
- Metric thread-setter kit
- Angle drill

## Explanatory Notes on Document

To provide you with a quick overview of the individual working steps, you will find an identification mark on the outside top right corner of the page in question.

### Mechanical system

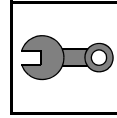

### Electrical system

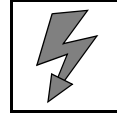

### Coolant circuit

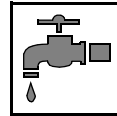

### Fuel

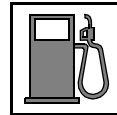

### Exhaust gas

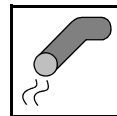

### Combustion air

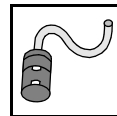

Special features are highlighted using the following symbols:



Specific risk of injury or fatal accidents.



Specific risk of damage to components.



Specific risk of fire or explosion.



Reference to general installation instructions of Webasto components or to the manufacturer's vehicle-specific documents.



Reference to a special technical feature.

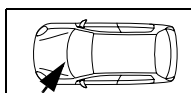
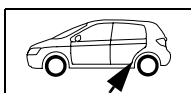

The arrow in the vehicle icon indicates the position on the vehicle and the viewing angle.

## Preliminary Work

### WARNING!

- Disconnect the battery "earth" or "ground" connection.
- Depressurise the cooling system.
- Copy the factory number from the original type label to the duplicate type label.
- Remove years that do not apply from the duplicate label.
- Attach the duplicate label (type label) in the appropriate place.
- Completely remove the battery.
- Open fuel tank cap, ventilate tank.
- Close the fuel tank cap again.
- Remove underride protection
- Remove A/C control panel in accordance with manufacturer's instructions.
- Remove the lower cover of the footwell on the front passenger side.
- Remove the A-pillar trim on the front passenger side (only with Telestart).

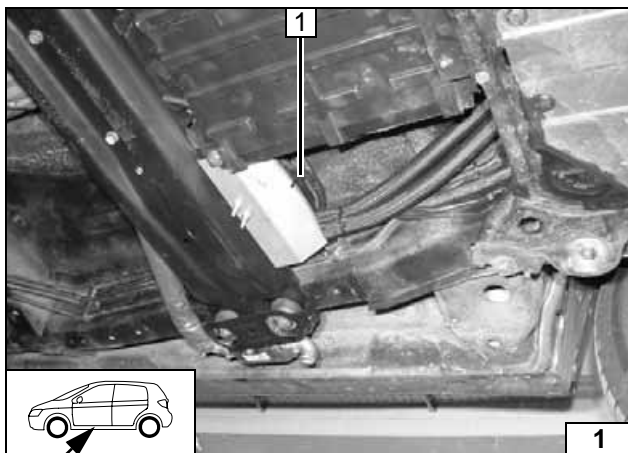

### Heater installation location

1 Heater

Installation location



## Preparing electrical system

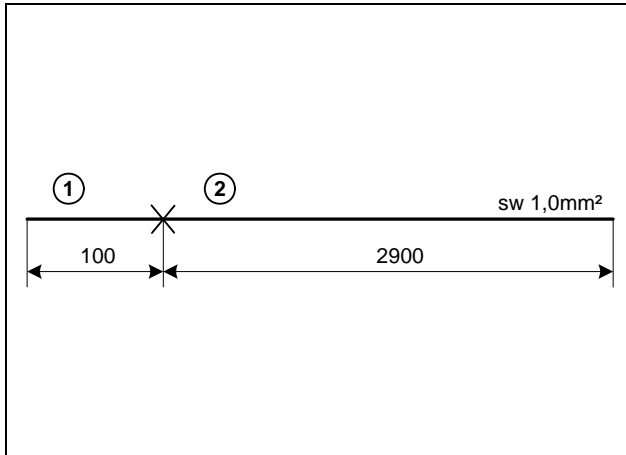

**Cutting wires to length**

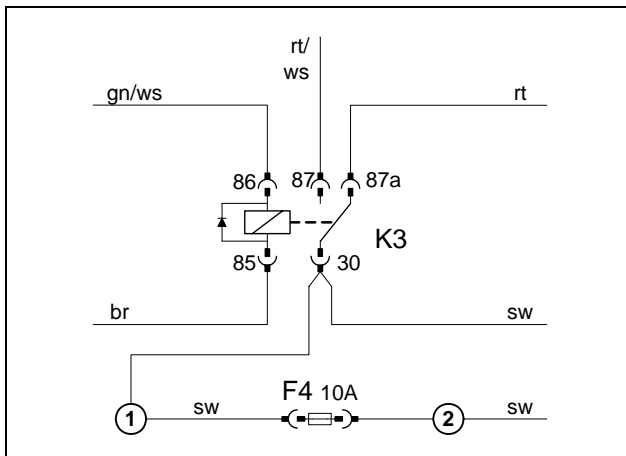

Produce connections as shown in wiring diagram.  
Draw wire section 2 into the included protective sleeving and route it later into the passenger compartment.



**Preparing fuse F4**



## Electrical system

### Positive and earth connection

- 1 Earth wire to original vehicle earth support point
- 2 Positive wire on positive distributor of positive battery terminal

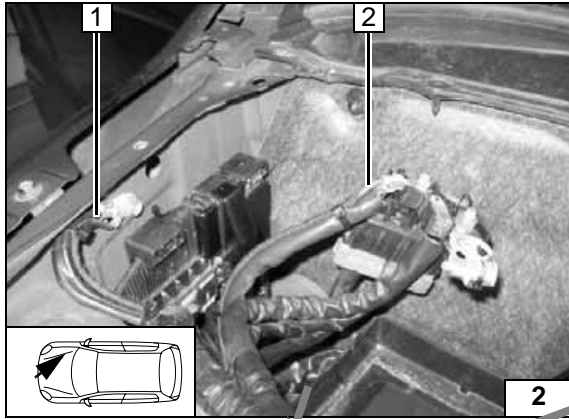

### Wiring harness pass through

- 1 Protective rubber plug
- 2 Wiring harness of fan control, digital timer and additional black (sw) wire in the protective sleeving

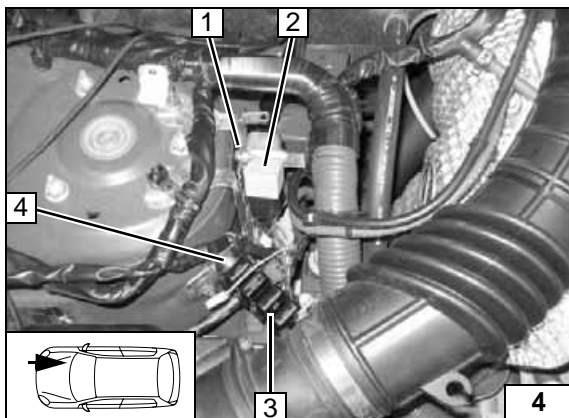
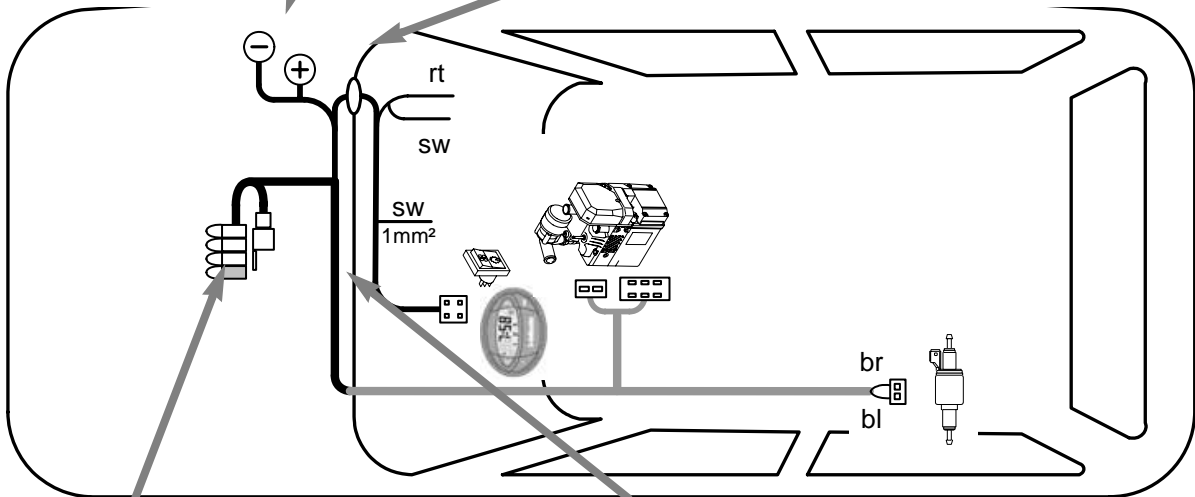
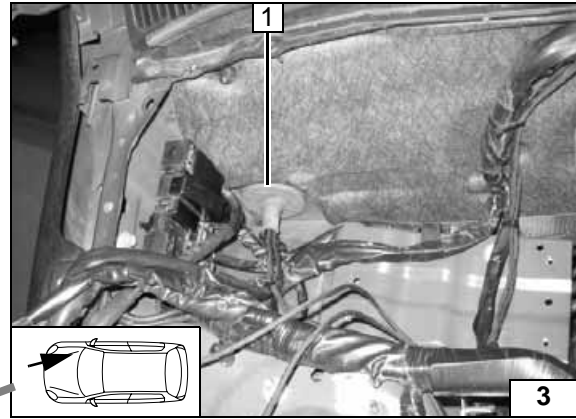

### Fuse holder, K3 relay

- 2 K3 relay
- 1 Bend lug, M5x12 bolt, washer [2x], flanged nut on existing hole
- 4 Retaining plate of fuse holder, M5x12 bolt, washer [2x], flanged nut on existing hole
- 3 Fuse holder

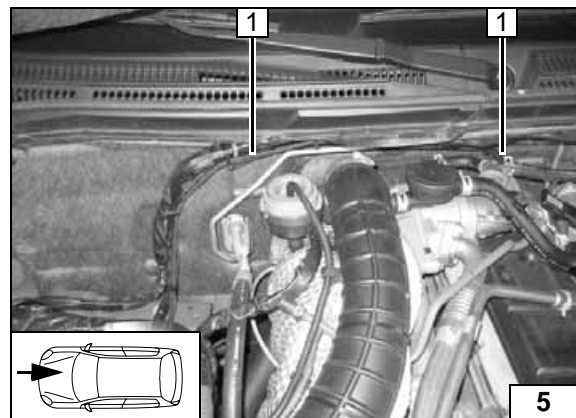

### Routing of wiring harnesses

- 1 Route wiring harness of heater to the installation location of the metering pump



Wiring harness routing diagram

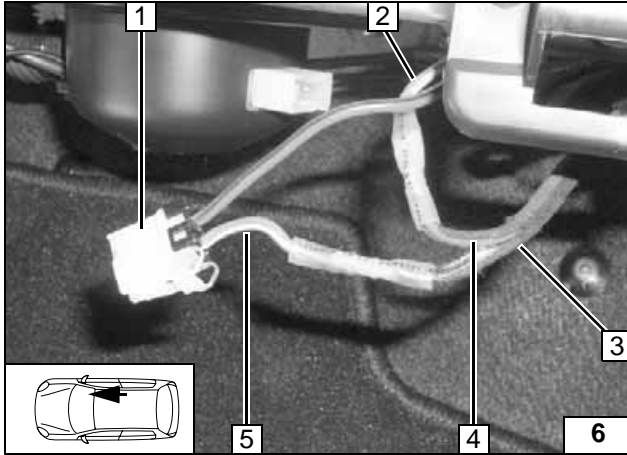

## Fan control

Connection to 2-pin connector **1** from the fan motor.  
Make connections according to wiring diagram with included connectors.

- 2** Blue/white (bl/ws) wire from fan relay
- 4** Red (rt) wire from K3/87a
- 5** Blue/white (bl/ws) wire to connector of fan motor
- 3** Black (sw) wire from K3/30



**Connect-  
ing fan mo-  
tor**

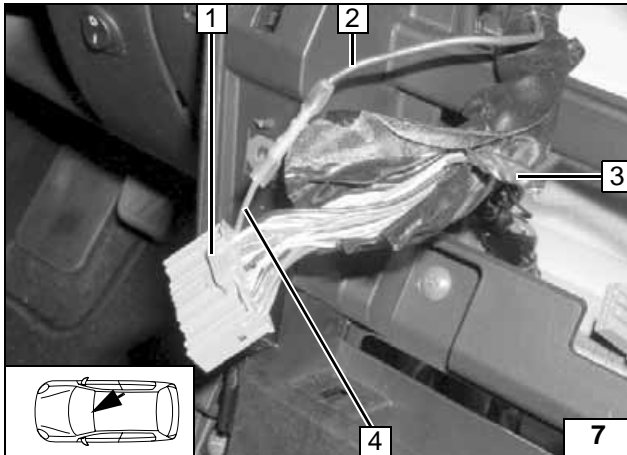

Connection to 32-pin gray connector **1** G52.  
Make connections according to wiring diagram with included connector.

- 2** Black (sw) wire from Fuse F4
- 4** Original vehicle violet/red (vi/rt) wire from connector of G52 Pin 1
- 3** Original vehicle violet/red (vi/rt) wire from fuse F40, insulated



**Connect-  
ing A/C  
control  
panel**

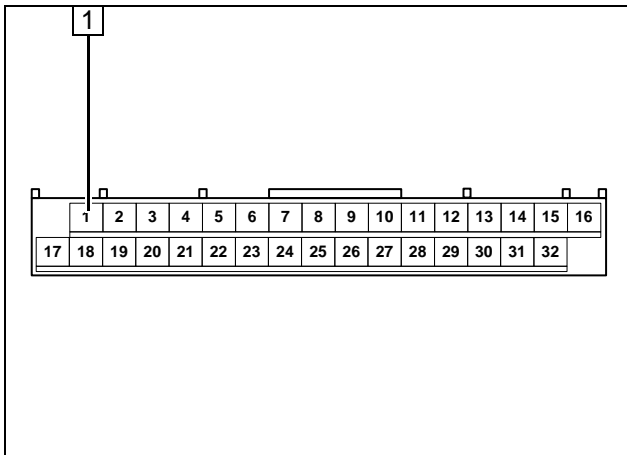

**1** Pin 1 of G52 connector on contact side



**Connector  
of A/C control  
panel**



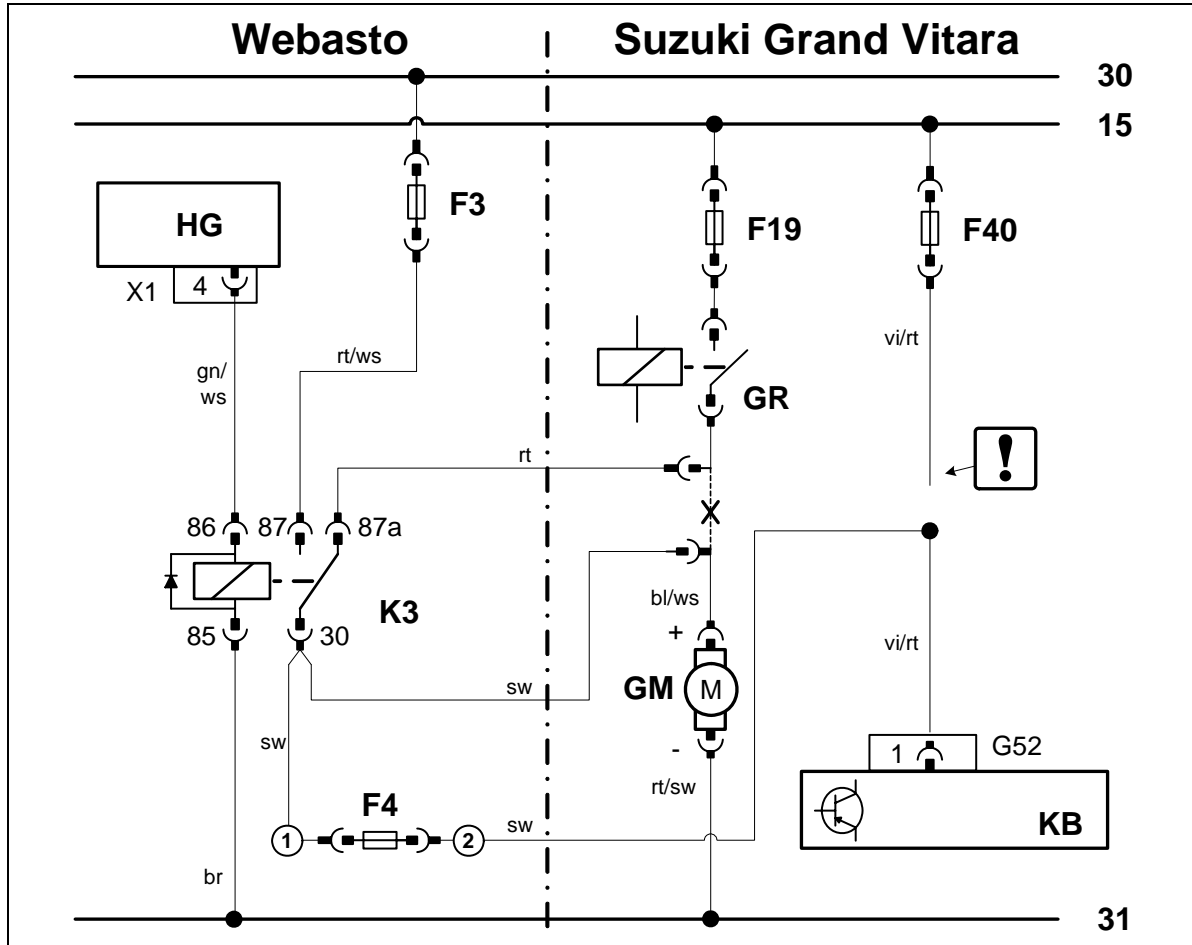

Automatic air-conditioning wiring diagram

| Webasto components |                        | Suzuki components |                                | Colours and symbols |                                 |
|--------------------|------------------------|-------------------|--------------------------------|---------------------|---------------------------------|
| HG                 | Heater TT-C/E          | GM                | Fan motor                      | rt                  | red                             |
| X1                 | 6-pin heater connector | GR                | Fan relay                      | ws                  | white                           |
| F3                 | Fuse                   | KB                | Air-conditioning control panel | sw                  | black                           |
| K3                 | 25A Fan relay          | G52               | 32-pin connector KB            | br                  | brown                           |
| F4                 | Additional fuse 10A    | F19               | 40A fuse                       | gn                  | green                           |
|                    |                        | F40               | 10A fuse                       | bl                  | blue                            |
|                    |                        |                   |                                | vi                  | violet                          |
|                    |                        |                   |                                | !                   | Insulate wire ends and tie back |
|                    |                        |                   |                                | X                   | Cutting point                   |
|                    |                        |                   |                                |                     | Wiring colours may vary.        |

Legend

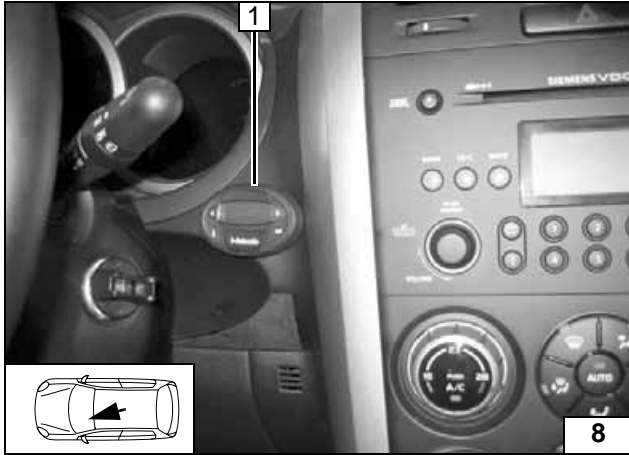

**Digital timer**

- 1 Digital timer



**Installing digital timer**

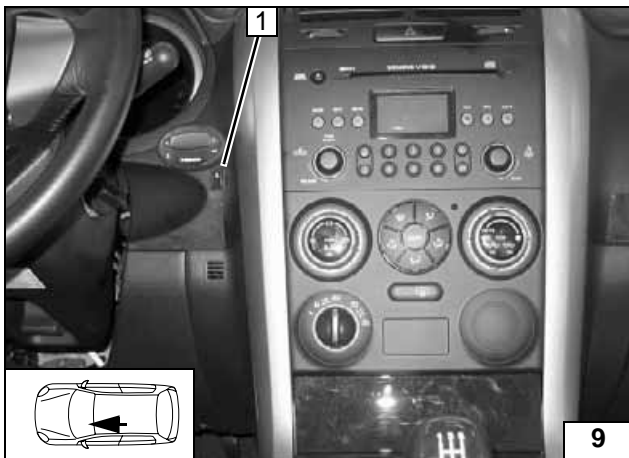

**Summer/winter switch option**

- 1 Summer/winter switch, 12 mm dia. hole



**Installing Summer / Winter switch**

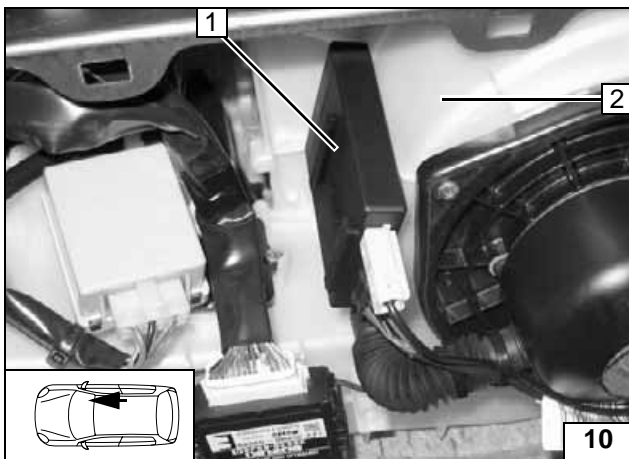

**Remote option (Telestart)**

- 2 Fan housing
- 1 Receiver, velcro strip (self-adhesive)



**Installing receiver**

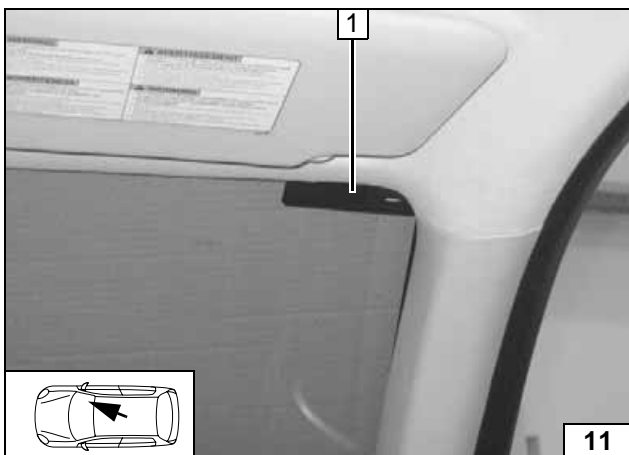

- 1 Antenna

**Installing antenna**

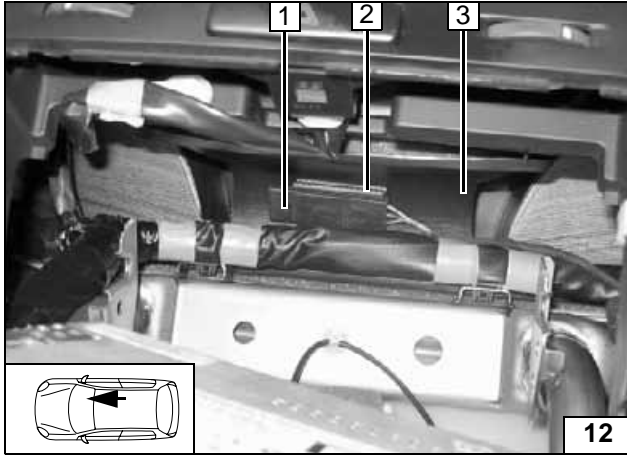

## Temperature sensor (only for T100 HTM)

- 1 Temperature sensor
- 2 Velcro strip (self-adhesive)
- 3 Air duct

**Installing temperature sensor**

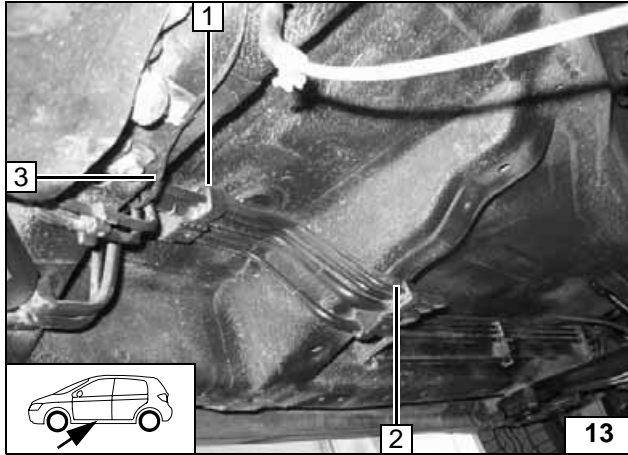
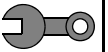

## Preparing installation location

Route wiring harness of heater **2** up to position **1**, make loop, and guide back to installation location of heater. Route metering pump cable **3** to installation location of metering pump.



**Routing wiring harness**

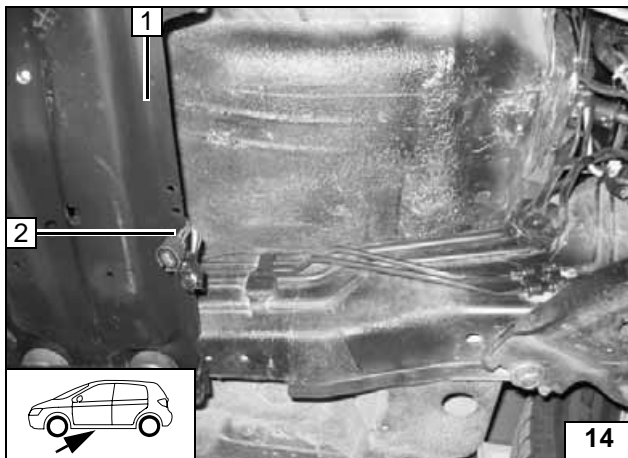

- 1 Installation location of heater
- 2 Wiring harness of heater

**Routing wiring harness**

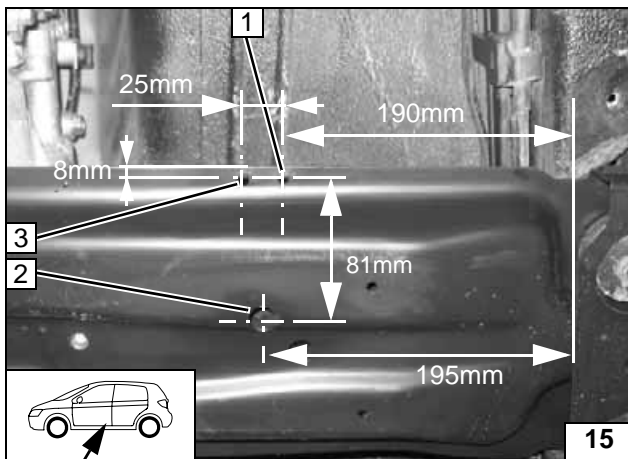

Copy hole pattern as shown. Drill holes at Position **1** and **3** to 7 mm dia. Drill hole at Position **3** through both levels first 7 mm dia., and later drill lower level to 16 mm dia.



**Drilling holes**

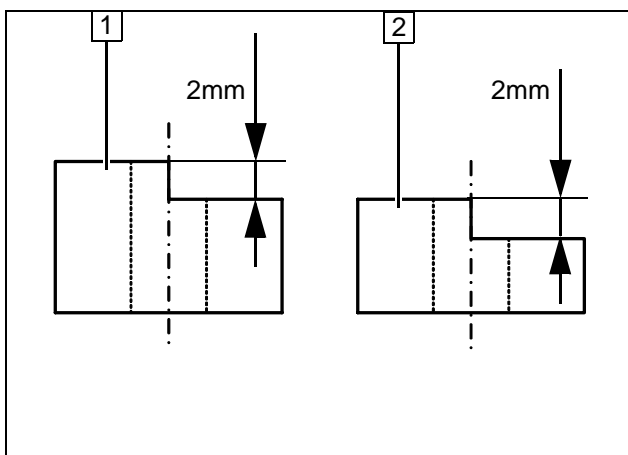

Machining included shims as shown.

- 1 8mm spacer
- 2 5mm spacer



**Preparing shims**

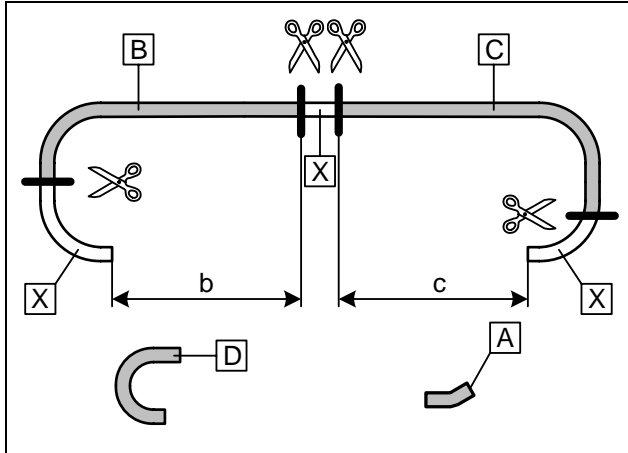
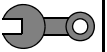

## Preparing heater

Included 30°, 20mm dia. hose  
Included 180°, 20mm dia. moulded hose

b = 975mm  
c = 780mm

Discard section **X**  
Cut away hose **C** just behind elbow

**Cutting coolant hoses to length**

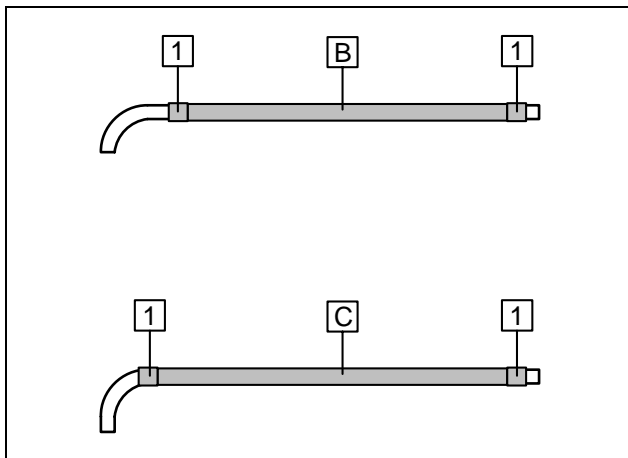

Push braided protection hose onto hoses **B** and **C** and cut to length.  
Divide heat shrink plastic tubing into 4 equal ends, slide on and shrink

1 Heat shrink plastic tubing [4x]

**Preparing coolant hoses**

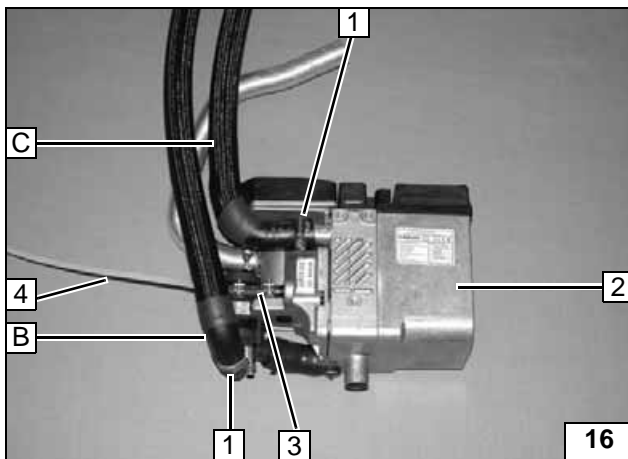

Fasten hose **C** with 90° elbow on heater coolant outlet, hose **B** with 90° elbow on circulating pump.

- 1 27mm dia. hose clamp [2x]
- 2 Heater
- 4 Mecanyl fuel line
- 3 Hose section, 10 mm dia. hose clamp [2x]

**Premounting heater**

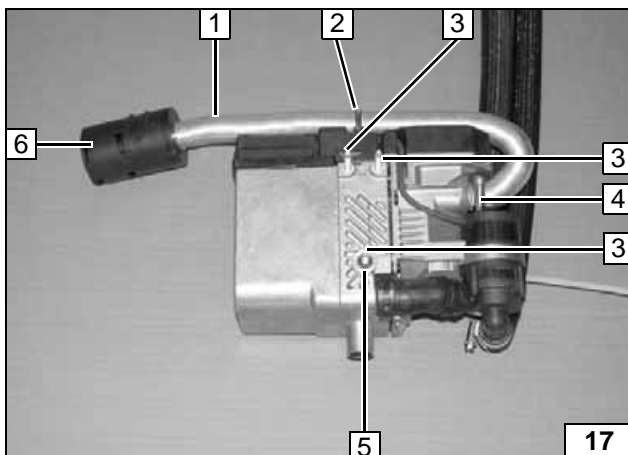

Ensure proper installation position of combustion-air intake silencer, see "Installation Instructions".  
Break through perforation in heater cover, insert retaining clip **2**.

- 1 Combustion-air intake pipe
- 3 E-jot stud [3x]
- 4 27 mm dia. hose clamp
- 5 10mm spacer, pin lock
- 6 Combustion-air intake silencer

**Premounting intake silencer**

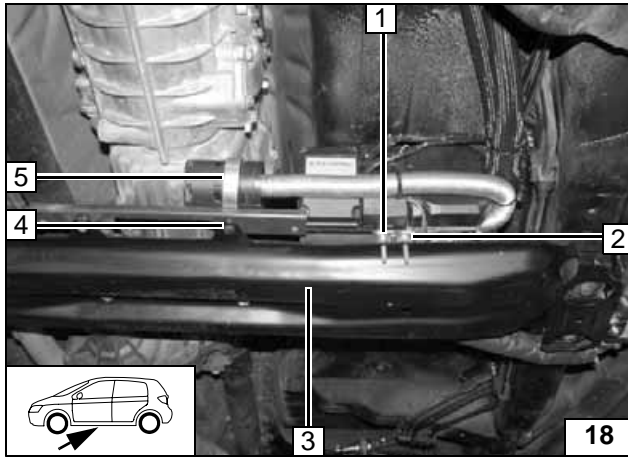
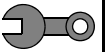

## Installing heater

Before installing the heater, the cross member **3** is to be lowered and the original vehicle bolt at Position **4** is to be replaced by an M6x30 bolt.

- 1 Recessed 8mm spacer
- 2 Recessed 5mm spacer, large diameter washer
- 5 48 mm dia. rubber clamp removed, 5mm spacer, M6 flanged nut



**Installing heater loosely**

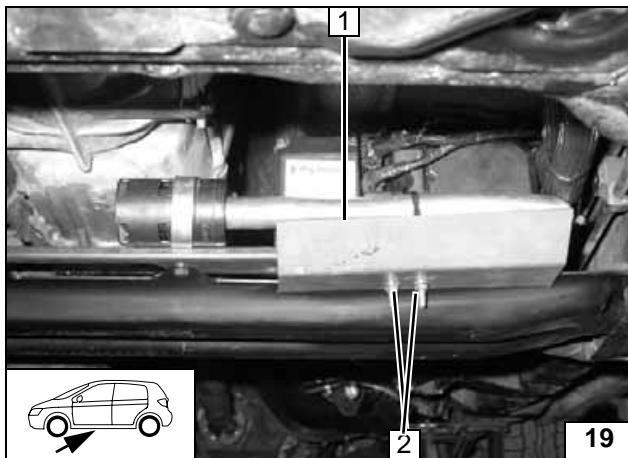

- 1 Wind deflector plate
- 2 M6 flanged nut [2x]

**Installing wind deflector plate**

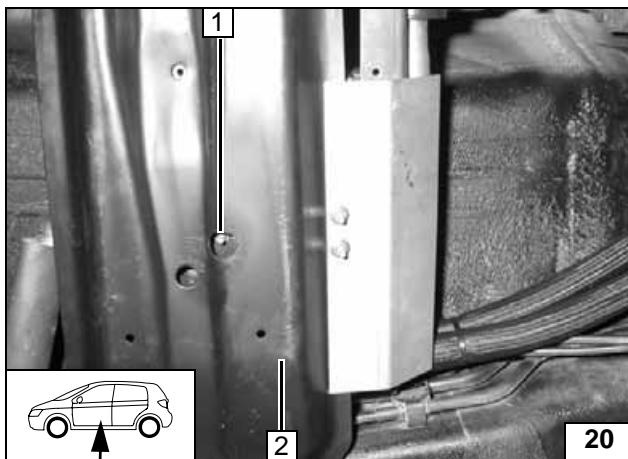

- 1 M6 flanged nut

**Installing heater**

Re-tighten cross member **2**



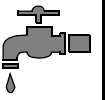

**Coolant circuit**

**WARNING!**

Any coolant running off should be collected using an appropriate container. Install hoses so that they are kink-free. Unless specified otherwise, always fasten using cable ties. Position clamps so that no other hose can be damaged! When installing the hoses, the heater must be filled with coolant. The connection should be "inline" based on the following diagram:

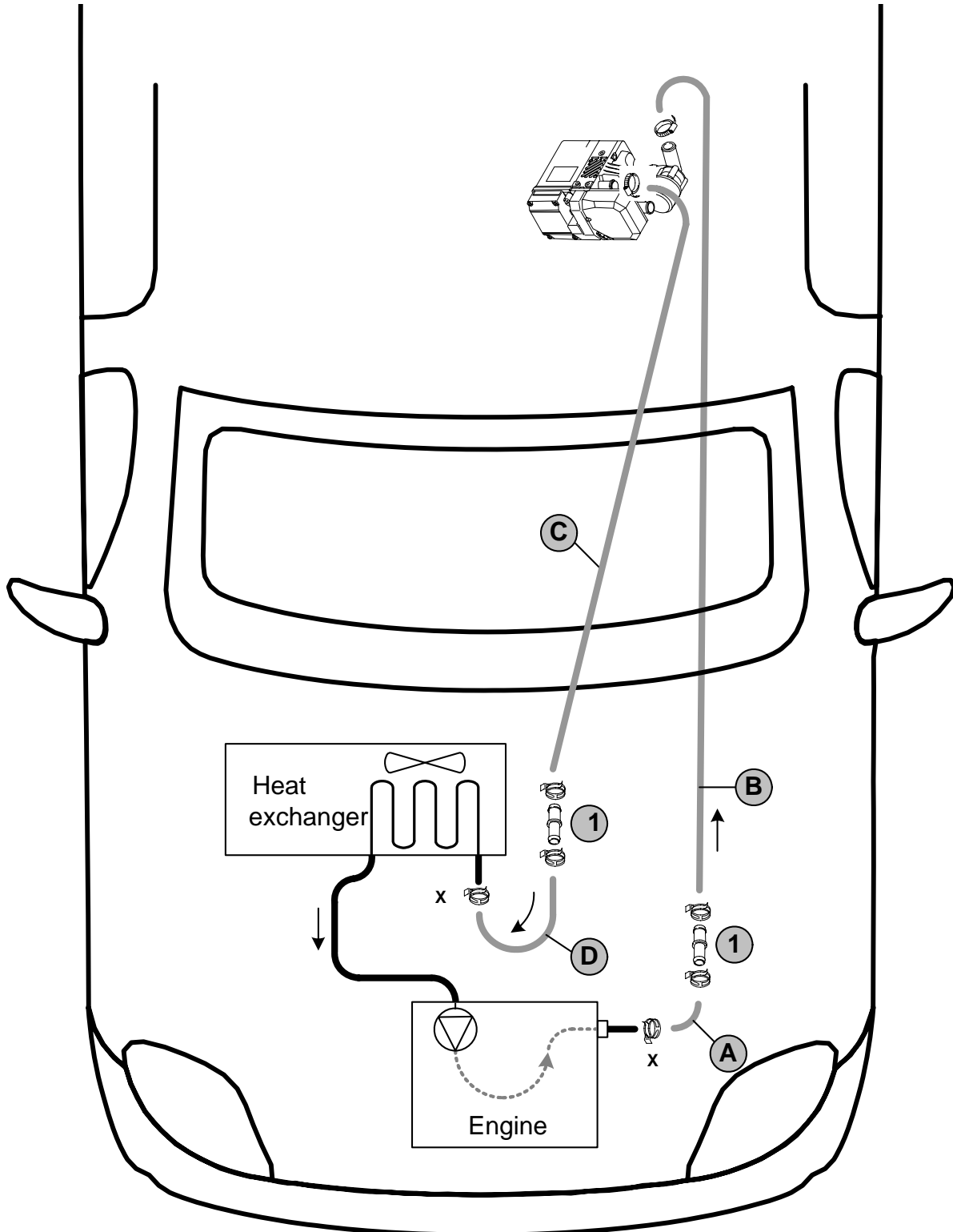

Hose routing diagram

All not designated clamps = 20-27mm dia. hose clamps Position X = original vehicle spring clamps.  
 1 Connecting pipe = 20x20mm dia. with 27mm dia. spring clip



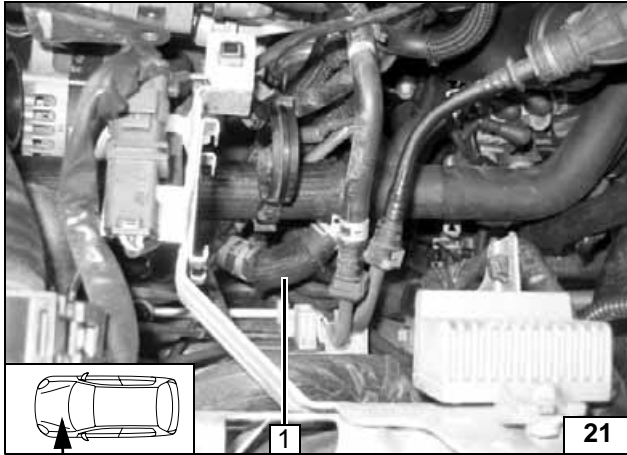
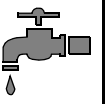

Remove original vehicle hose **1** from engine outlet of heat exchanger inlet and discard. Spring clamps will be reused.



**Cutting point**

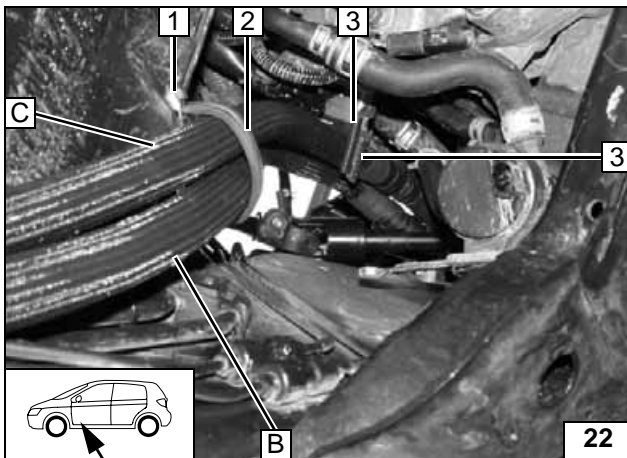

Ensure sufficient distance to neighbouring components.

- 1** 9.1mm dia. hole, M6 rivet nut, M6x20 bolt, spring lockwasher
- 2** Rubber-coated pipe clamp, 48 mm dia.
- 3** Edge protection [2x]



**Routing to underbody**

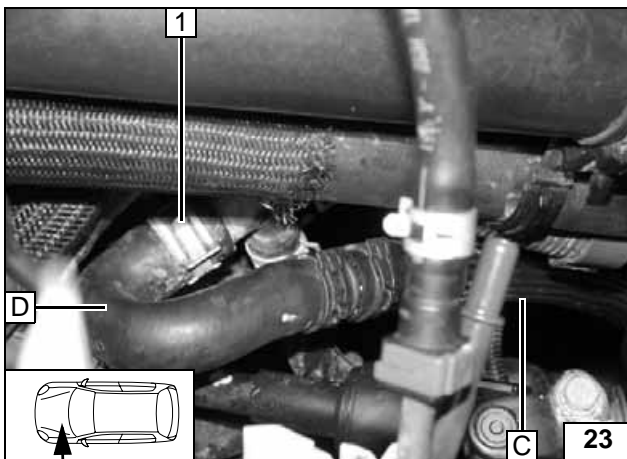

**1** Original vehicle spring clip

**Connection to heat exchanger inlet**

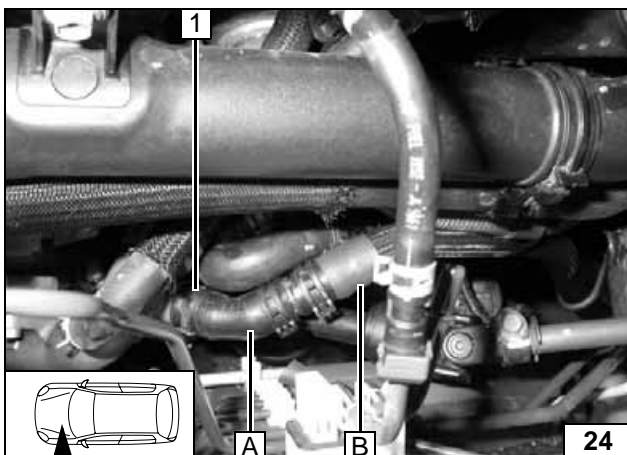

**1** Original vehicle spring clip

**Connection to engine outlet**



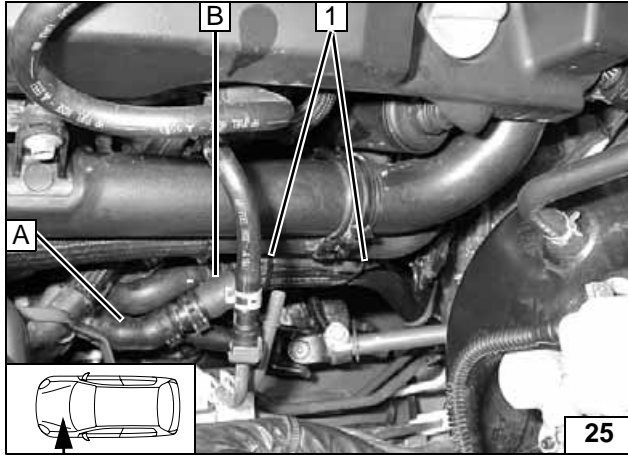

Check coolant hoses over entire length, correct if necessary. Fasten coolant hose **B** with cable tie **1** on wiring harness.



Routing in engine compartment



## Fuel

### CAUTION!

Open the vehicle's fuel tank cap, ventilate the tank and then re-close the tank lock.

Catch any fuel running off with an appropriate container.

Install fuel line and metering-pump wiring harness so that they are protected against stone impact. Unless specified otherwise, always fasten using cable ties.

Mount the fuel line and wiring harness with rub protection on sharp edges.

### WARNING!

The fuel line and wiring harness are routed to the metering pump in as shown in the wiring harness routing diagram.

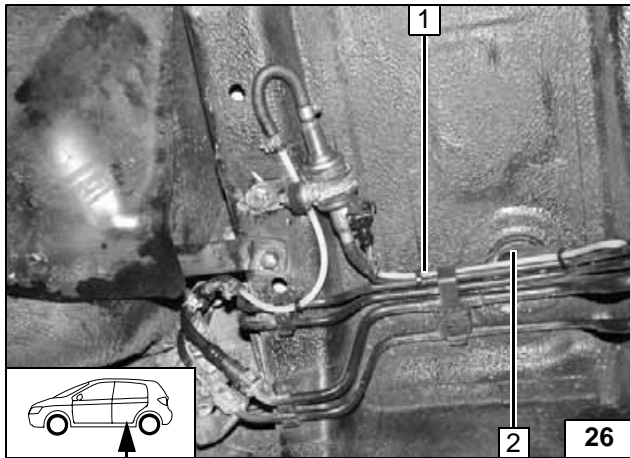

- 1 Fuel line from heater
- 2 Metering pump wiring harness

### Routing line

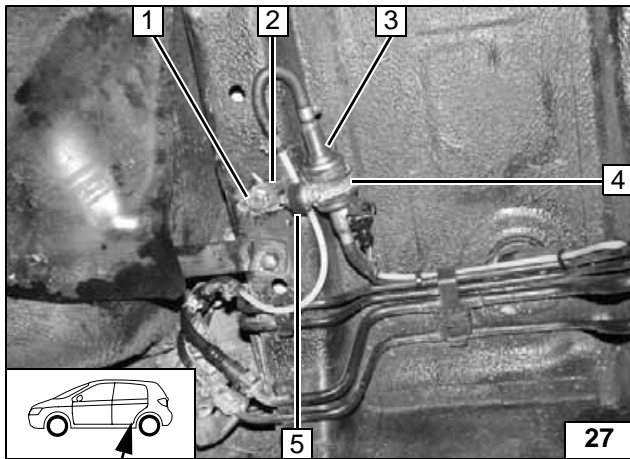

- 1 M8x20 bolt, washer, spring lockwasher on existing threaded hole
- 2 Angle bracket
- 3 Metering pump
- 4 Rubber-coated pipe clamp
- 5 Silent block, flanged nut [2x]

### Installing metering pump

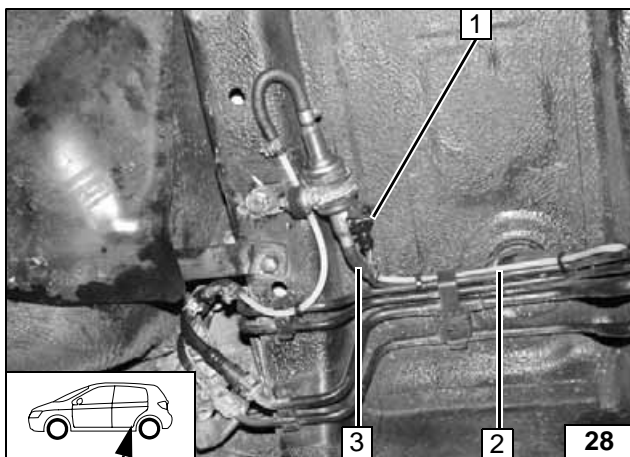

Fuel line of heater on pressure side of metering pump [side with connector].

- 2 Mecanyl fuel line
- 3 Hose section, 10 mm dia. hose clamps [2x]
- 1 Wiring harness of metering pump, single wire sealings, tab connector [2x], connector housing



### Connecting metering pump

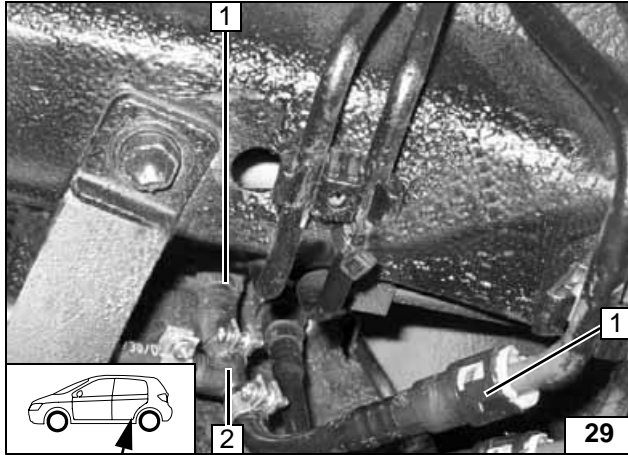

Pull out fuel supply line 1 as shown and insert fuel standpipe!

2 Cutting point, fuel standpipe, 10 mm dia. hose clamp [2x]



**Removing fuel**

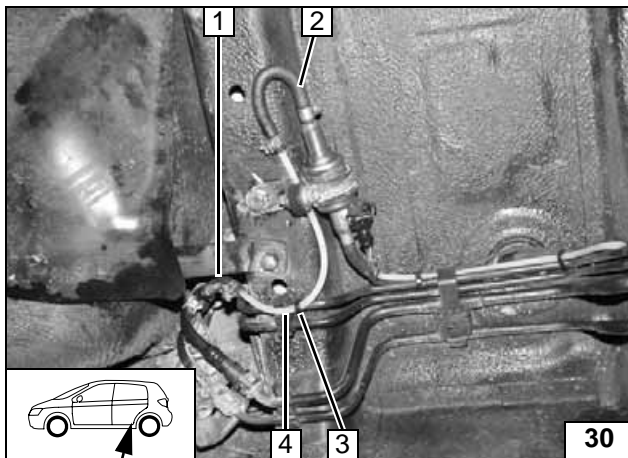

1 Hose section, 10 mm dia. hose clamp [2x]

2 180° moulded hose, hose clamp [2x]

3 Cable tie

4 Mecanyl fuel line

**Connect-  
ing meter-  
ing pump**

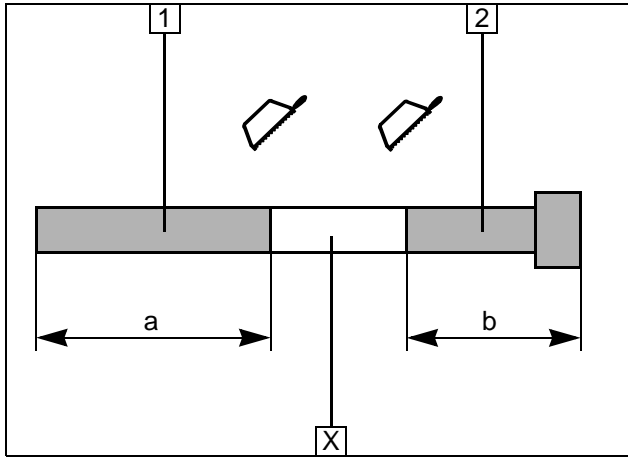
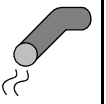

## Exhaust gas

- 1 Exhaust pipe  
a = 560mm
- 2 Exhaust end section  
b = 90mm

Discard section X

Preparing exhaust pipe

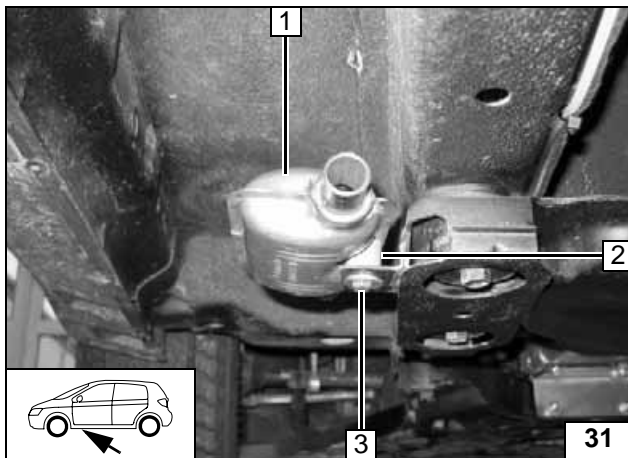

- 1 Silencer
- 2 20mm spacer
- 3 M6x40 bolt, large diameter washer, flanged nut on existing hole

Installing silencer

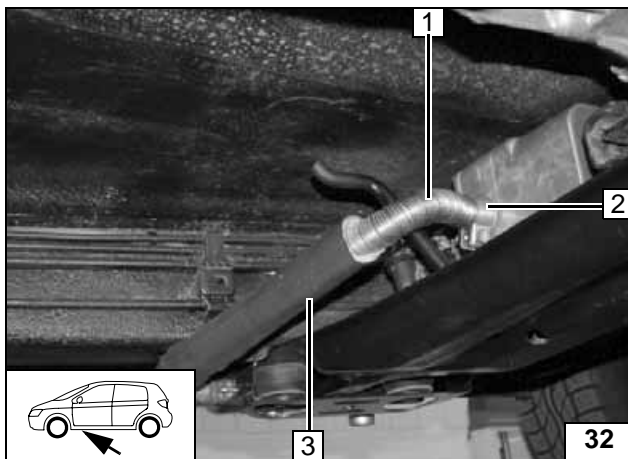

Slide on exhaust-gas insulation 3 on exhaust pipe.

- 1 Exhaust pipe
- 2 Hose clamp [2x]



Installing exhaust pipe

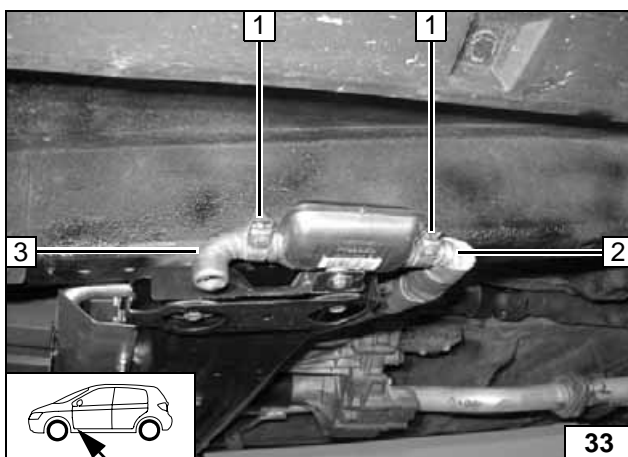

- 2 Exhaust pipe
- 3 Exhaust end section
- 1 Hose clamp [2x]

Installing exhaust pipe and end section

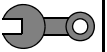

## Final Work

### WARNING!

Reassemble the disassembled components in reverse order. Check all hoses, clamps and all electrical connections for firm seating. Insulate and tie back all loose wires.

Only use manufacturer-approved coolant. Spray the heater components with anti-corrosion wax (Tectyl 100K, Order No. 111329).

- Connect the battery.
- Fill and bleed the coolant circuit according to the vehicle manufacturer's specifications.
- Adjust digital timer, teach Telearstart transmitter
- Make settings on A/C control panel according to the "Operating Instructions for End Customer".
- Place sticker "Switch off parking heater before refilling" in the area of the filler neck
- For initial start up and function check, see installation instructions

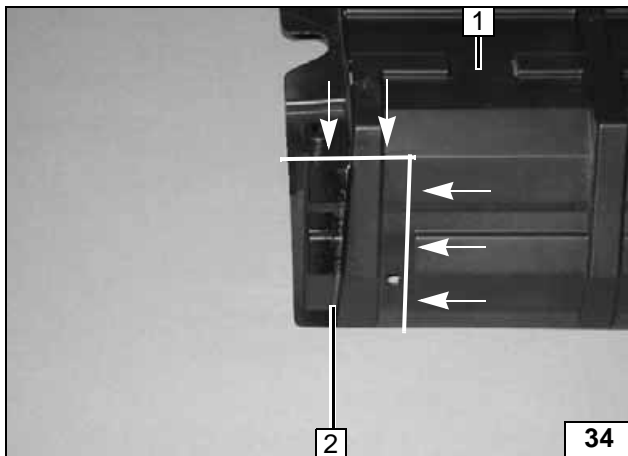

Cut out underride protection 1 at the marking.

2 Discard section



Cutting out  
underride  
protection

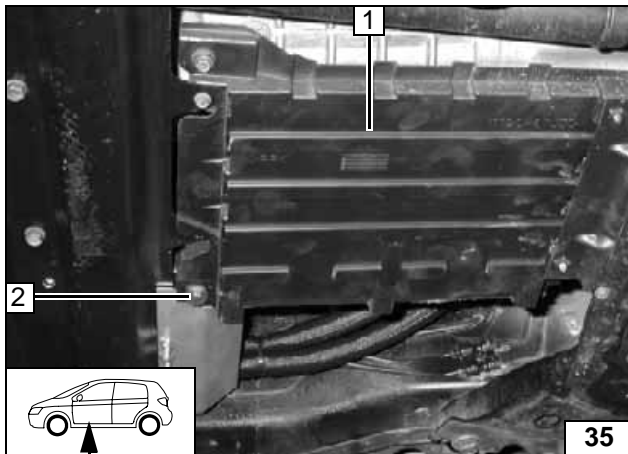

1 Underride protection

2 M6x30 bolt, large diameter washer, 10mm spacer

Installing  
underride  
protection

**Webasto**  
*Feel the drive*

Webasto AG  
Postfach 80  
D-82132 Stockdorf / Germany  
National Hotline: 01805 93 22 78  
(14 Cent aus dem deutschen Festnetz)  
Hotfax: 0395 5592 353  
Hotmail: technikcenter@webasto.com  
<http://www.webasto.com>

## Operating Instructions for End Customer

Please remove page and add to the vehicle operating instructions.

### Note:

We recommend matching the heating time to the driving time.

Heating time = driving time

### Example:

For a driving time of approx. 20 min. (in one direction), we recommend not exceeding a switch-on time of 20 min.

In vehicles with passenger compartment monitoring it must be deactivated additionally, besides deactivating the vehicle settings for the heating operation.

Instructions on deactivation can be taken from the operating instructions of the vehicle

### WARNING!

The fording capability and the off-road capability of the vehicle are limited due to the parking heater being installed on the underbody.

Massive mechanical effects on the underbody (e.g., through floor contacts) are to be avoided!

The vehicle may be immersed no further than the underside of the body. The heater should not be operated during water crossing.

Non-observation of these instructions can lead to the heater being damaged.

Damages on account of such non-compliance are not covered by the warranty!

Before parking the vehicle, make the following settings:



### Note:

The "Circulating air" operation indicator flashes during heating.

- 1 Set temperature to max. "28°"
- 2 Air outlet to windscreen
- 3 Set fan to max. 1/3

Automatic  
air-conditioning