

Water Heater



Thermo Top E Parking Heater

00 0003

Thermo Top C Parking Heater

00 0002

Installation documentation

Honda Civic

Diesel
from model year 2006
Left-hand drive vehicle
Automatic air-conditioning



WARNING!

Hazard warning:

Incorrect installation or repair of Webasto heating systems may cause a fire or result in the emission of carbon monoxide, which can be fatal. Serious or fatal injuries can be caused as a result.



Specialist company training, technical documentation, specialised tools and equipment are required to install and repair Webasto heating and cooling systems. Only original Webasto parts must be used. For this, also see the catalog of air and water heater accessories from Webasto.

NEVER attempt to install or repair Webasto heating or cooling systems if you have not successfully completed the company training and thereby acquired the required technical skills, or if you do not have access to the required technical documentation, tools and equipment needed to carry out correct installation and repairs.

ALWAYS follow all Webasto installation and repair instructions and observe all warnings.

The initial startup is to be executed with the Webasto Thermo Test Diagnosis.

Webasto does not accept any liability for defects and damage that are attributable to installation by untrained staff.

Table of Contents

Validity	2	Preparing heater	11
Heater / Installation Kit	3	Preparing installation location	11
Foreword	3	Installing heater	13
General Instructions	3	Combustion air	12
Special Tools	3	Coolant circuit	14
Explanatory Notes on Document	4	Fuel	18
Preliminary Work	5	Exhaust gas	20
Heater installation location	5	Final Work	21
Preparing electrical system	6	Operating Instructions for End Customer	22
Electrical Connections	7		
Fan control	8		
Remote option (Telestart)	10		

Validity

Manufacturer	Model	Type	EG-BE No./ ABE
Honda	Civic	FK	e11 * 2001 / 116 * 0257 * ...

Engine type	Engine model	Output in kW	Displacement in cm ³
N22A	Diesel	103	2204

Vehicle and engine types, equipment variants and national specifications not listed in these installation instructions have not been tested. However, installation according to these installation instructions may be possible.

The installation location of a digital timer and summer/winter switch should be confirmed with the end customer before installation.

Heater / Installation Kit

Quantity	Designation	Order No.:
1	Retail accessories <i>Thermo Top C/E</i>	See price list
1	Installation kit for Honda Civic 2006 Diesel	1311075C
1	Heater control	See price list

Heater recommended for the respective vehicle class:

Vehicle	Heater
Compact car	Thermo Top E
Mid-size car, estate car	Thermo Top C

The selection of the heater is based on the passenger compartment size of the vehicle and the level of comfort required by the customer.



Foreword

This installation documentation applies to the Honda Civic Diesel vehicles - for validity, see page 2 - from model year 2006 and later, assuming technical modifications to the vehicle do not affect installation, any liability claims excluded. Depending on the vehicle version and equipment, modifications may be necessary during installation with respect to this installation documentation.

However, the stipulations in this "installation documentation" the "operating and maintenance instructions" and the "installation instructions of the *Thermo Top C/E* must always be observed.

The corresponding rules of technology and any information from the vehicle manufacturer should be observed during the installation work.

General Instructions

Installation should be carried out according to the general, standard rules of technology. Unless specified otherwise, fasten hoses, lines and wiring harnesses to original vehicle lines and wiring harnesses using cable ties. Insulate loose lines and tie back

Sharp edges should be fitted with rub protection (split-open fuel hose).

Spray unfinished body areas, e.g. drilled holes, with anti-corrosion wax (Tectyl 100K, Order No. 111329). When installing an IPCU, the corresponding settings must be checked and adjusted before the installation.

Special Tools

- Torque wrench for 2.0 - 10 Nm
- Hose clamping pliers
- Metric thread-setter kit

Explanatory Notes on Document

To provide you with a quick overview of the individual working steps, you will find an identification mark on the outside top right corner of the page in question.

Mechanical system

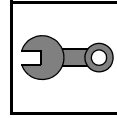

Electrical system

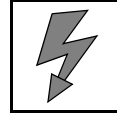

Coolant circuit

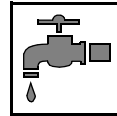

Fuel

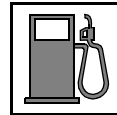

Exhaust gas

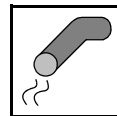

Combustion air

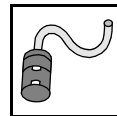

Special features are highlighted using the following symbols:



Specific risk of injury or fatal accidents.



Specific risk of damage to components.



Specific risk of fire or explosion.



Reference to general installation instructions of Webasto components or to the manufacturer's vehicle-specific documents.



Reference to a special technical feature.

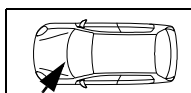
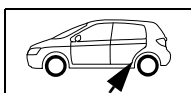

The arrow in the vehicle icon indicates the position on the vehicle and the viewing angle.

Preliminary Work

WARNING!

- Disconnect the battery "earth" connection.
- Depressurise the cooling system.
- Copy the factory number from the original type label to the duplicate type label.
- Remove years that do not apply from the duplicate label.
- Attach the duplicate label (type label) in the appropriate place.
- Completely remove the battery
- Remove the air filter together with the intake hose.
- Open the fuel tank cap, ventilate the tank.
- Close the fuel tank cap again.
- Remove the entire underride protection
- Remove the centre console trim and the centre tunnel
- Open the centre tank-fitting service lid.
- Remove the glove compartment (only with Telestart).
- Remove the trim below the steering column
- Remove the A/C control panel.

Please remove page 23 of the "Operating instructions for the end customer" and add this to the vehicle operating instructions.

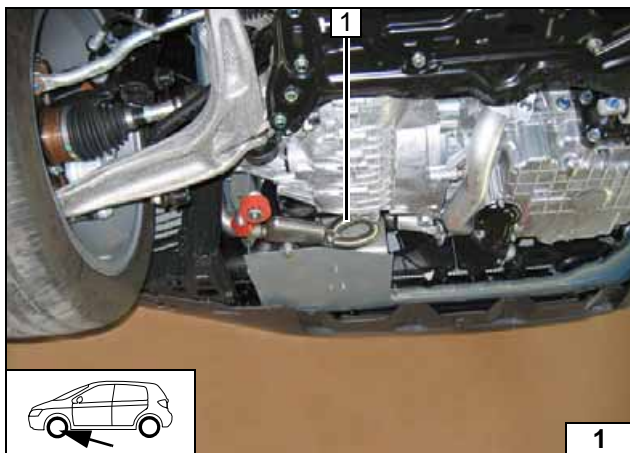

Heater installation location

1 Heater

Installation location

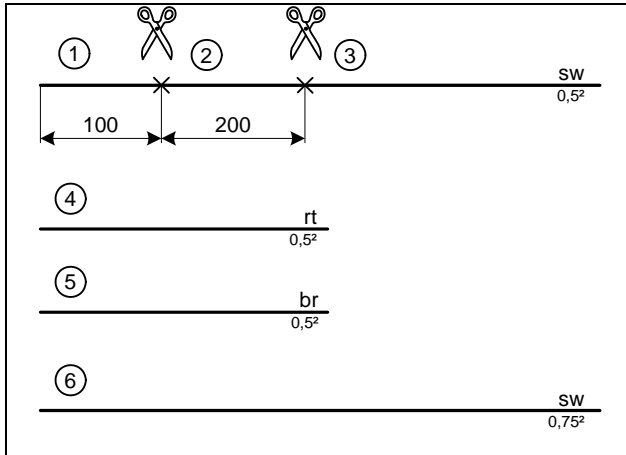

Preparing electrical system

Cut included black (sw) 0.5² wire to a length of 3000 mm as shown.



Cutting wires to length

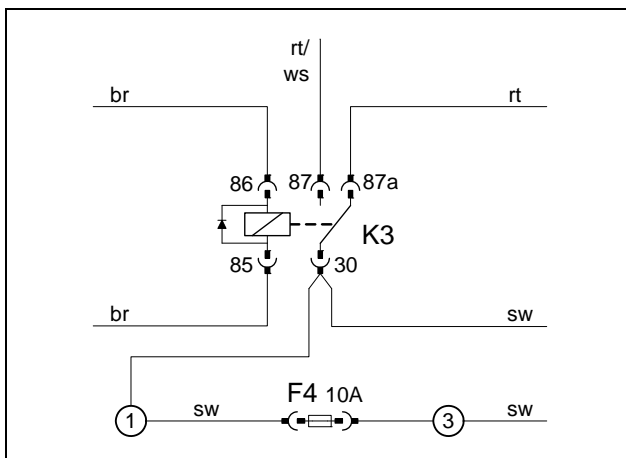

Pull wire section **3** into protective sleeving provided and route into passenger compartment together with clock and fan wiring harness.



Premounting 4th fuse

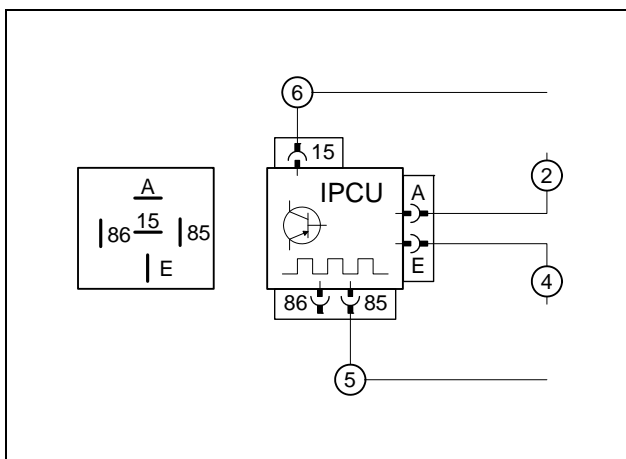

Connect wires to IPCU. IPCU view from contact side

The IPCU included in the kit is to be programmed with the following settings:

- Duty cycle:** 100%
- Frequency:** 14000Hz
- Voltage:** 2.8V
- Function:** High-side

The settings are to be checked and adjusted if necessary during heater startup.



Premounting IPCU



Electrical Connections

Wiring harness pass through

- 1 Protective rubber plug

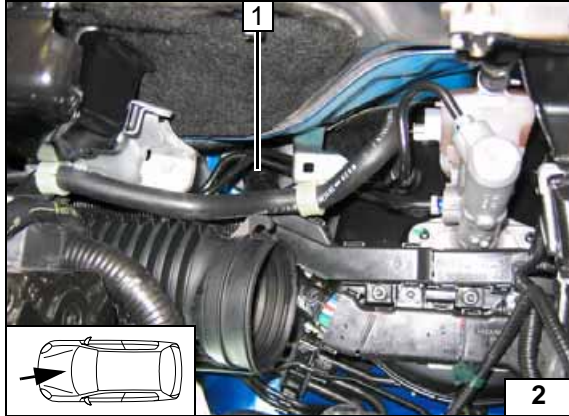

Digital timer

- 1 Digital timer

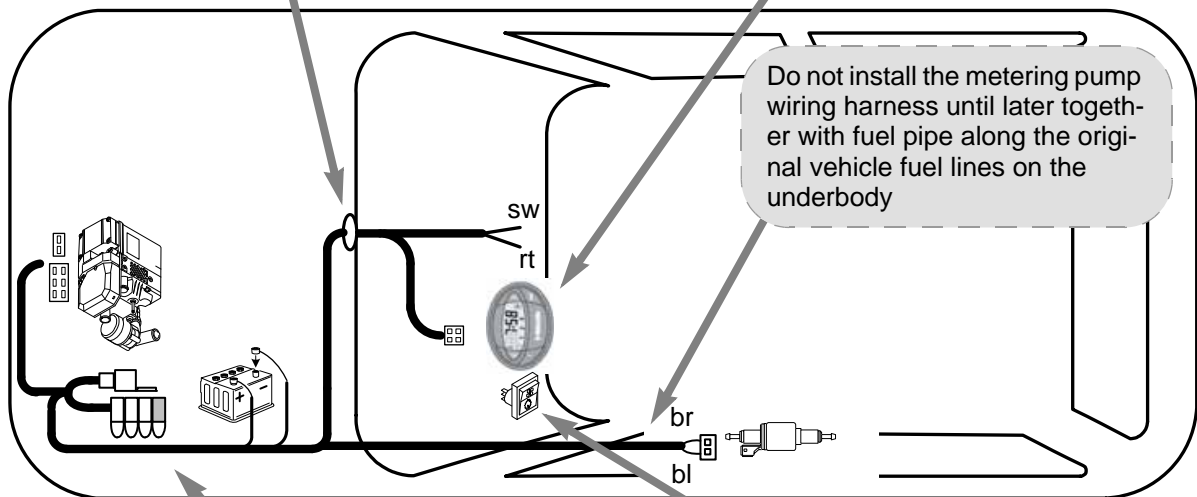
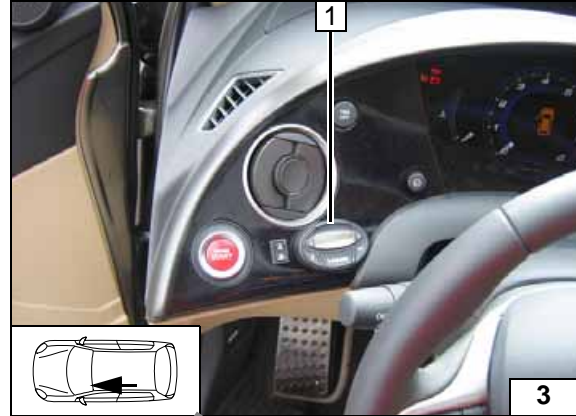

Wiring harness routing diagram

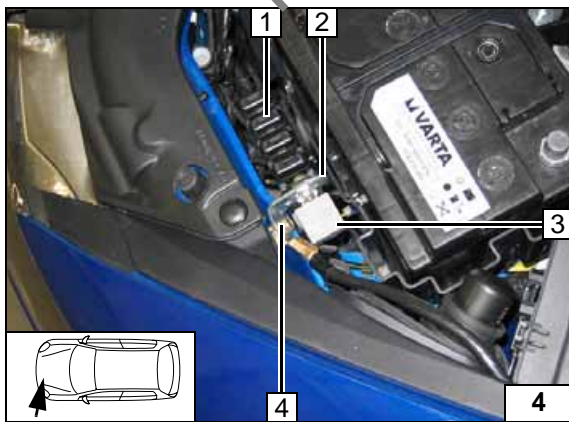

Fuse holder, K3 relay

- 1 Fuse holder with retaining plate, M5x16 bolt, washer, angle bracket
- 2, K3 relay
- 3, M5 flanged nut
- 4 Original vehicle bolt

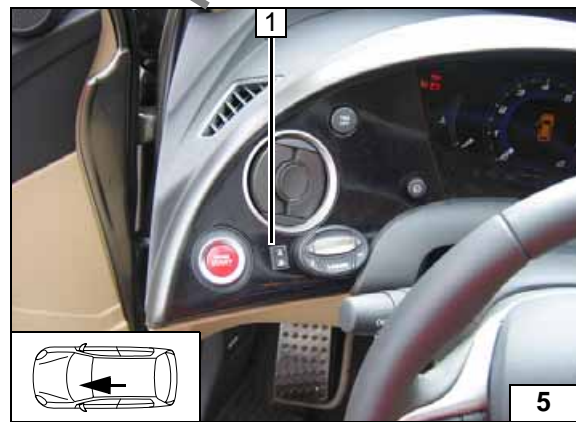

Summer/winter switch option

- 1 Summer/winter switch, drilled hole 12 mm dia.

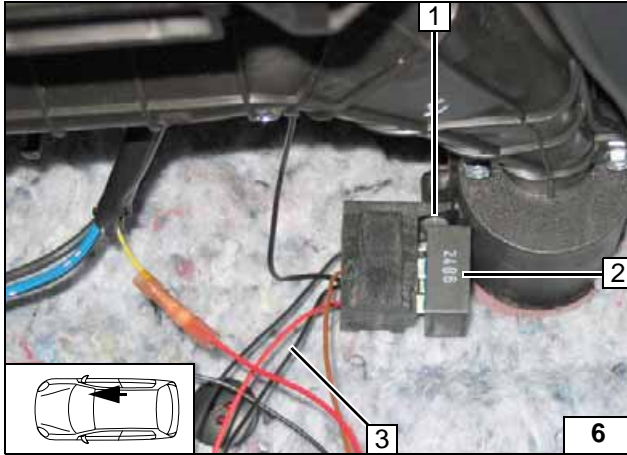

Fan control

Connect black (sw) wire ③ fuse F4 3 to the IPCU/86 socket.

- 1 Original vehicle bolt
- 2 IPCU mounted

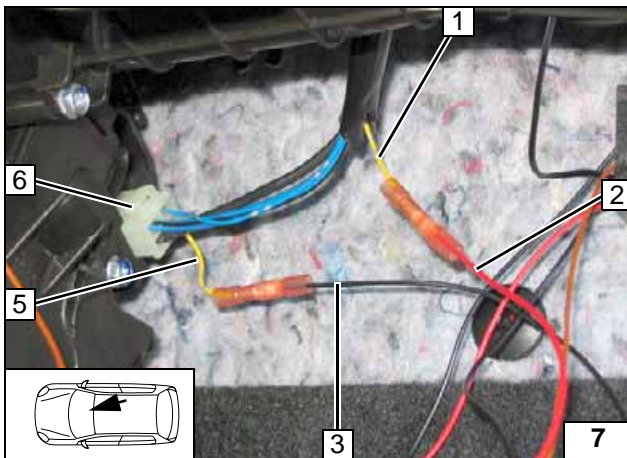

Connecting IPCU



Connection to 4-pin connector 6 from fan controller.

- 1 Yellow (ge) wire from A/C control panel
- 2 Red (rt) wire④ of IPCU/E
- 4 Black (sw) wire② of IPCU/A
- 5 Yellow (ge) wire to fan controller

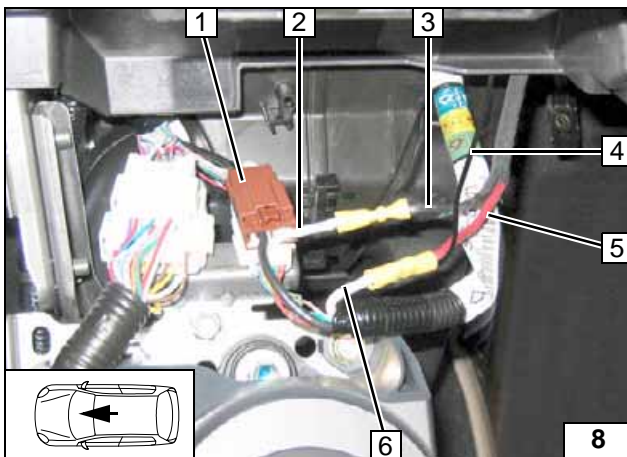

Connection of IPCU on fan controller



Connection on 2-pin connector 1 from wiring harness of fan relay to fan motor. Produce connections as shown in wiring diagram.

- 2 White (ws) wire of fan relay
- 3 Black (sw) wire from K3/30
- 4 Black (sw) wire⑥ of IPCU/15
- 5 Red (rt) wire to K3/87a
- 6 White (ws) wire of fan motor

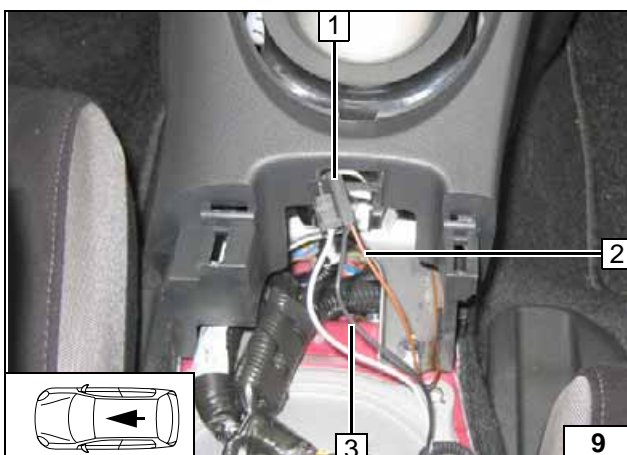

Connecting fan motor



Connect brown (br) wire ⑤ from IPCU/85 2 and black (sw) wire 3 from cigarette lighter.

- 1 Connector of cigarette lighter

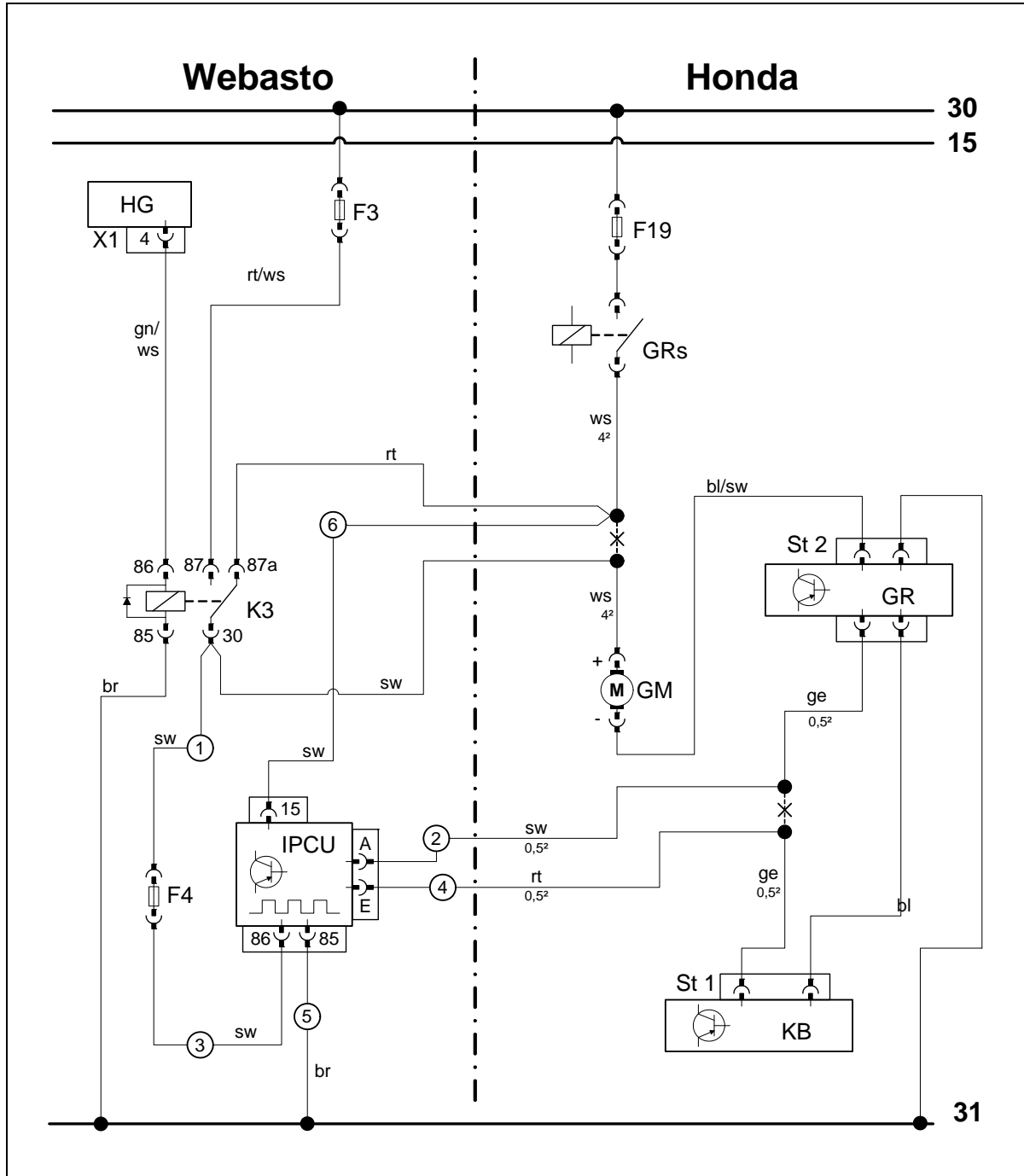

Connecting earth wire



Automatic air-conditioning wiring diagram

Webasto components		Components Honda Civic		Colours and symbols	
HG	Heater TT-C/E	GM	Fan motor	rt	red
X1	6-pin connector	GR	Fan relay	ws	white
F3	Fuse	KB	A/C control panel	sw	black
K3	Fan relay	F19	40A fuse	br	brown
F4	1A fuse	ST 1	32-pin connector	ge	yellow
IPCU	Pulse width modulator	ST 2	4-pin connector	bl	blue
IPCU settings:					
Duty cycle: 100%					
Frequency: 14000Hz					
Voltage: 2.8V					
Function: High-side					
				X	Cutting point
Wiring colours may vary.					

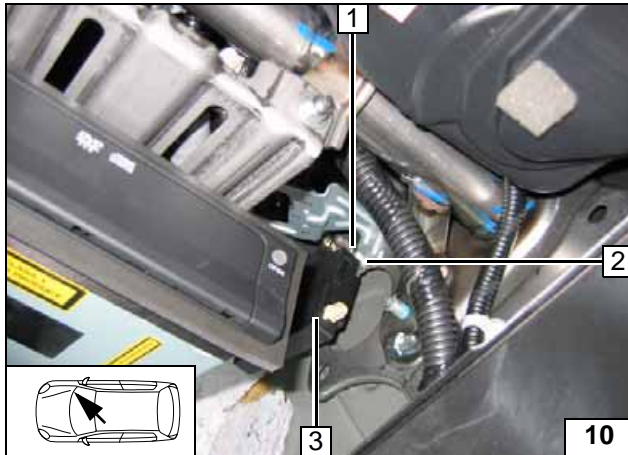
Legend



Remote option (Telestart)

- 1 Original vehicle bolt
- 2 Bracket, drill out hole to 7mm dia.
- 3 Receiver



Mounting receiver

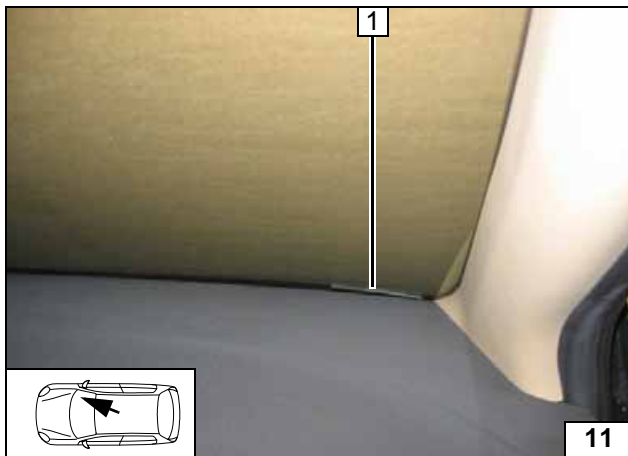

- 1 Antenna

Mounting antenna

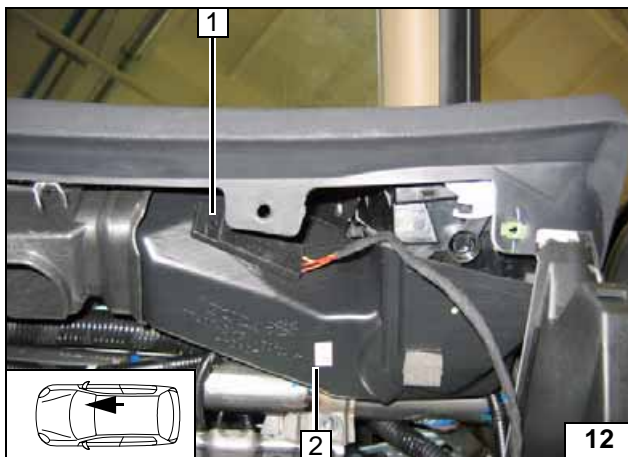

Temperature sensor T100 HTM

- 1 Fasten temperature sensor with installation strap
- 2 Original vehicle air duct

Mounting temperature sensor

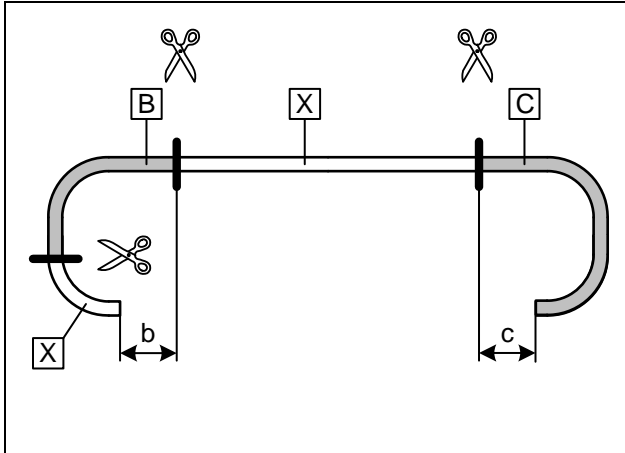
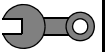

Preparing heater

Coolant hose 1 = 20mm dia.

b = 100 mm
c = 40 mm

Discard section X



Cutting coolant hose 1 to length

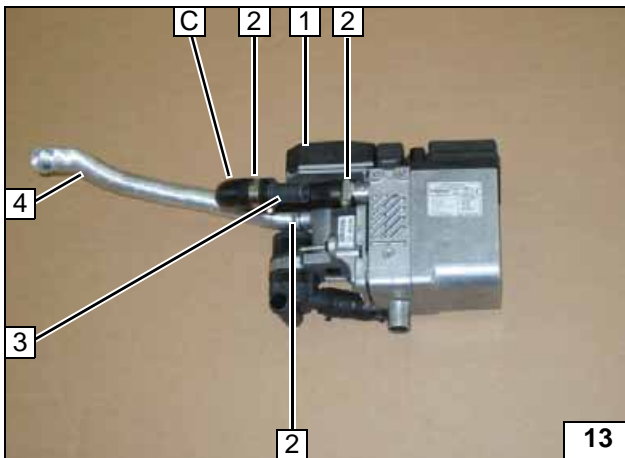

- 1 Heater
- 2 Hose clamp [3x]
- 3 18x20 connecting pipe
- 4 Combustion-air intake pipe

Premounting heater

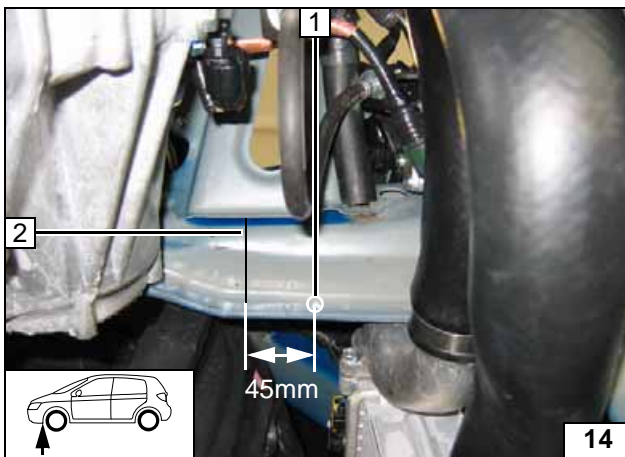

Preparing installation location

Copy hole pattern as shown onto centre of fold and drill 7 mm dia. hole 1.

2 Welding seam



Copying hole pattern

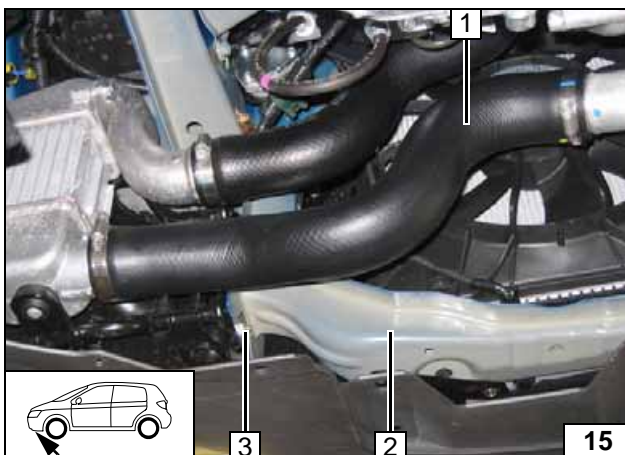

Remove lower hose of turbocharger 1.

- 2 Radiator carrier
- 3 Replace original vehicle bolt with M6x20 bolt



Preparing installation location

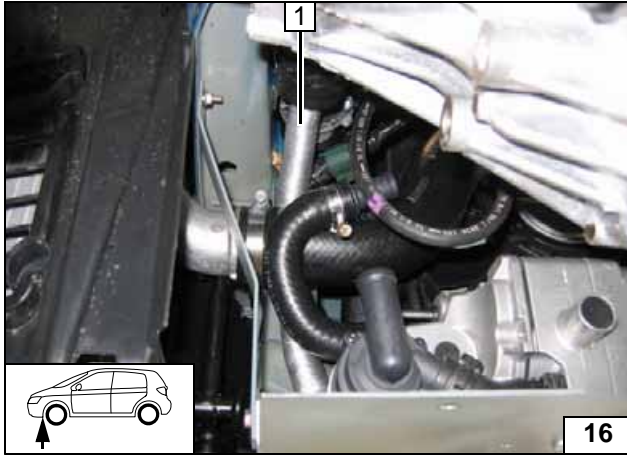
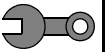

Combustion air

- 1 Combustion air pipe



Routing combustion air pipe

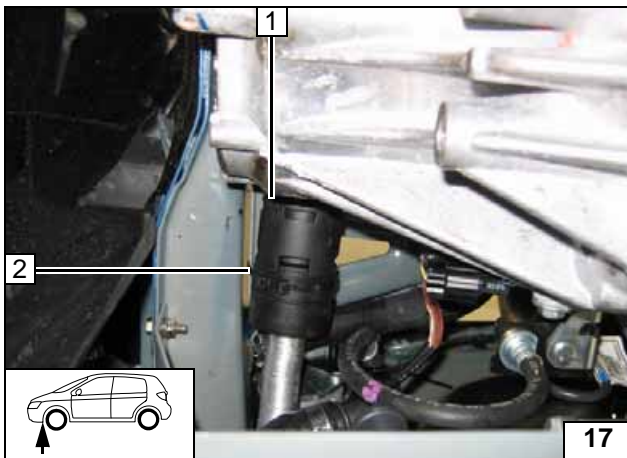

- 1 Silencer
- 2 Cable tie

Mounting silencer

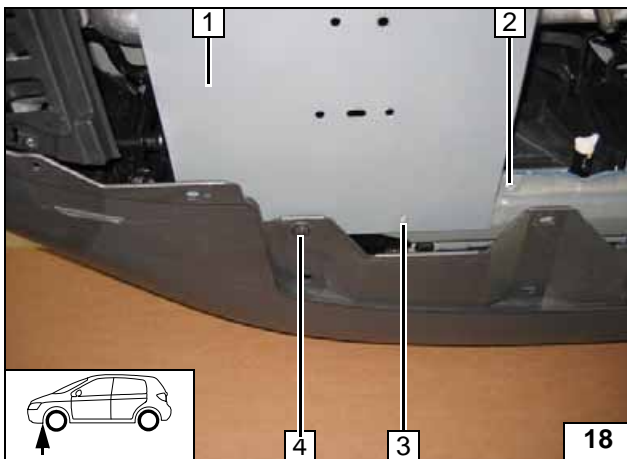

- 1 Bracket
- 2 Copy hole pattern, 7 mm dia. drilled hole
- 3 Copy hole pattern, drill 9 mm dia. hole and mount M6 rivet nut
- 4 Original vehicle bolt

Copying hole pattern

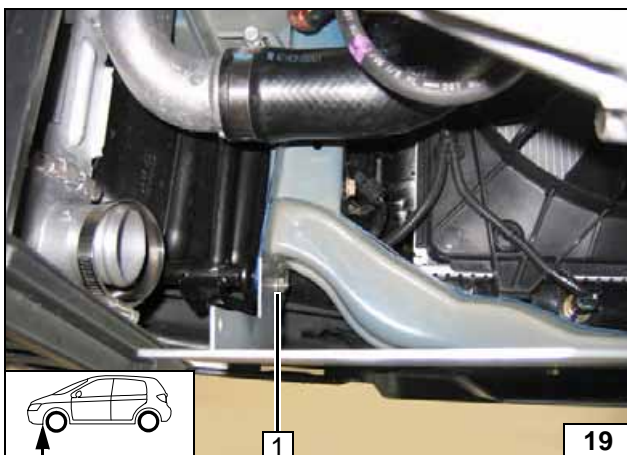

- 1 Pre-mounted M6x20 bolt, M6 flanged nut

Mounting bracket

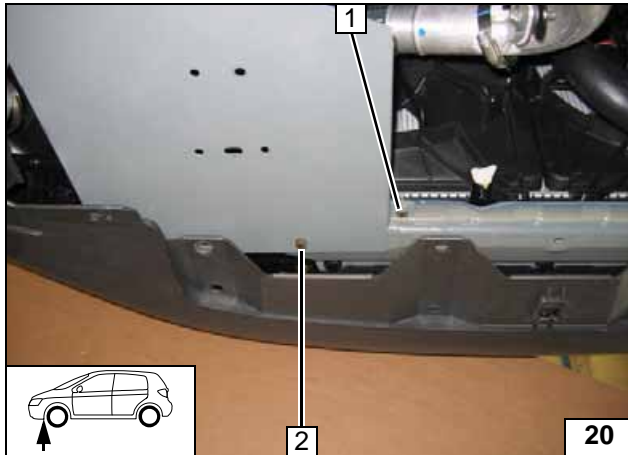
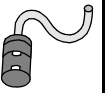

- 1 M6x20 bolt, large diameter washer, M6 flanged nut
- 2 M6x20 bolt, spring lock washer, M6 rivet nut

**Mounting
bracket**

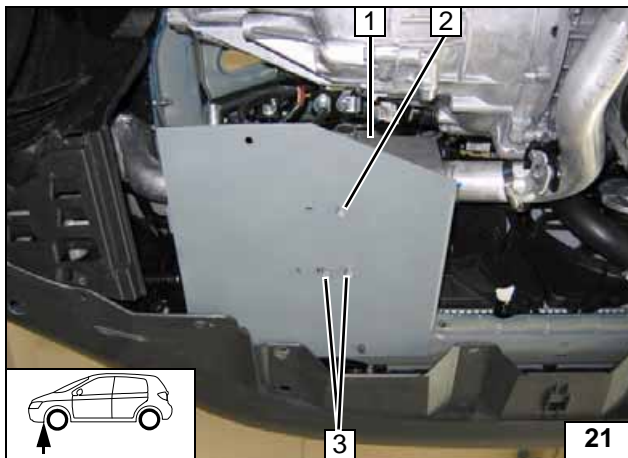

Installing heater

Tighten E-jot screws to 10 Nm.
Insert two washers between heater and bracket at position 2.

- 1 Heater
- 2 E-jot screw
- 3 E-jot screw [2x]



**Mounting
heater**

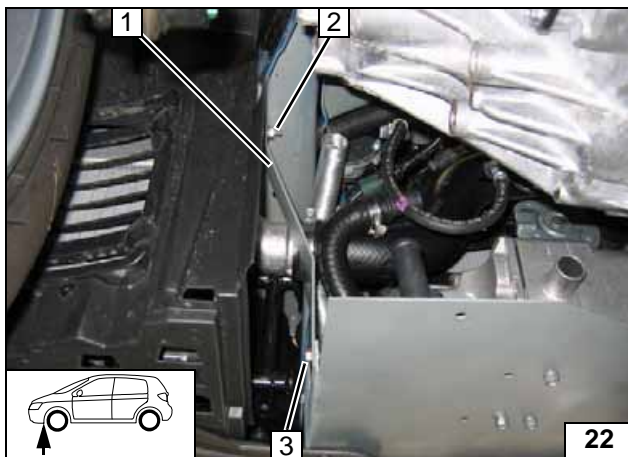

- 1 Strut
- 2 M6x20 bolt, M6 flanged nut
- 3 M6x12 bolt, spring lock washer, M6 rivet nut

**Mounting
strut**



Coolant circuit

WARNING!

Tighten all hose clamps to 2.0 + 0.5 Nm.

Any coolant running off should be collected using an appropriate container.

Route hoses so that they are kink-free. Unless specified otherwise, always fasten using cable ties. Position hose clamps and spring band clamps so that other hoses cannot be damaged.

The connection should be "inline" based on the following diagram:

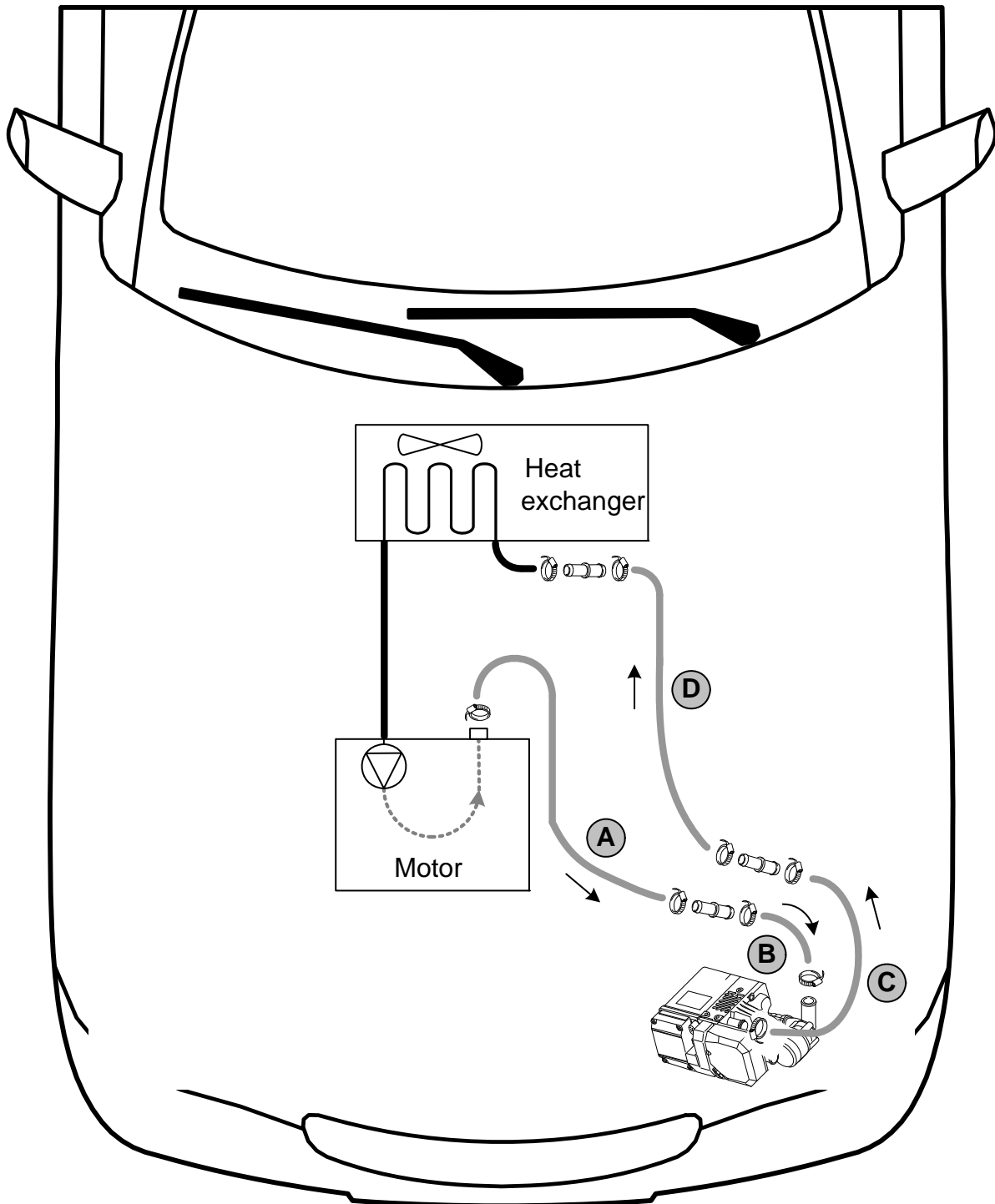

Coolant routing diagram

All clamps without a specific designation = 20-27 mm dia. hose clamps.
All connecting pipes = 18x20 dia..



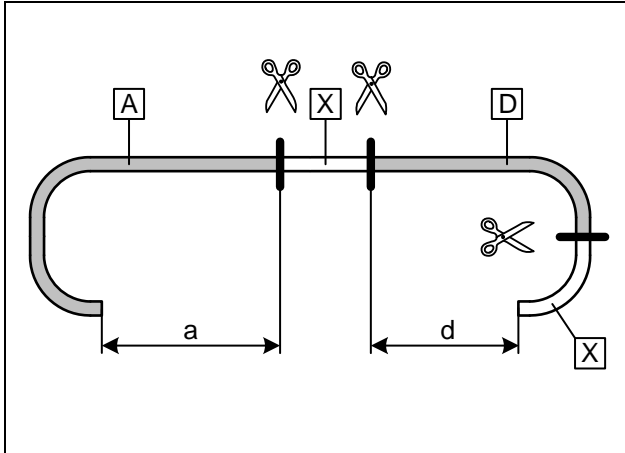

Coolant hose 2 = 18mm dia.

a = 580mm
d = 620mm

Discard section X



Cutting coolant hose 2 to length

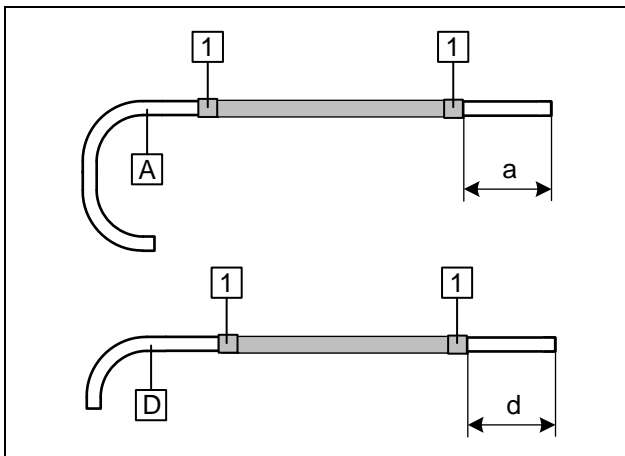

Cut braided protection hose in half and push onto hose A and D.
Cut heat shrink plastic tubing into 4 pieces.

1 25 mm heat shrink plastic tubing [4x]

a = 90 mm
d = 100 mm



Preparing coolant hoses

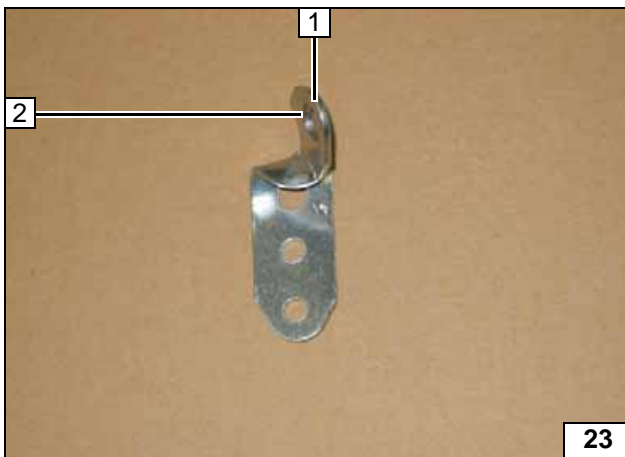

- 1 Perforated bracket
- 2 Drill out hole to 10 mm dia.

Bending perforated bracket

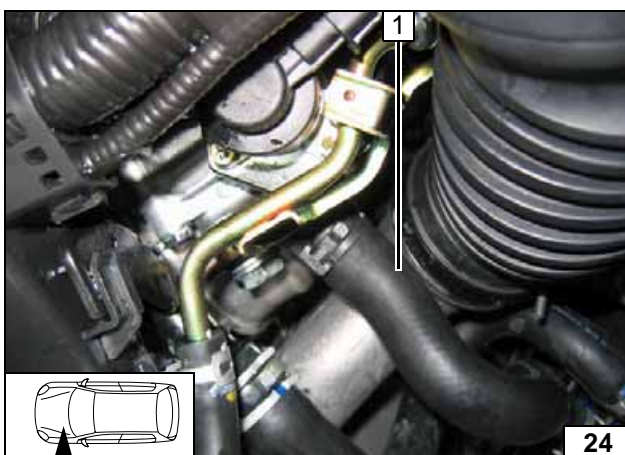

- 1 Pull off hose between engine outlet and heat exchanger inlet and discard clamp

Cutting point

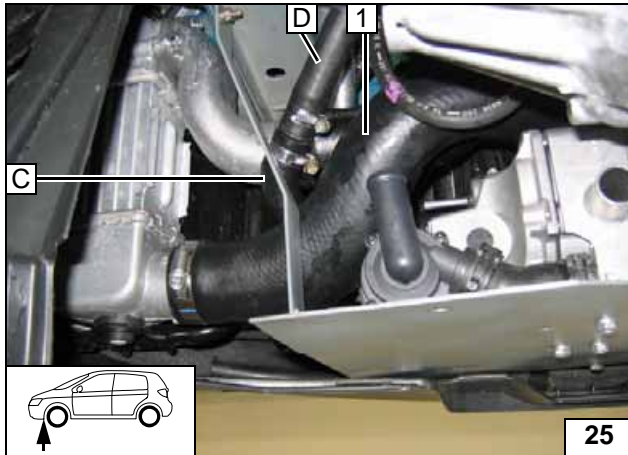

Install lower hose of turbocharger 1 turned by 180°.



**Conne-
tion on
heater**

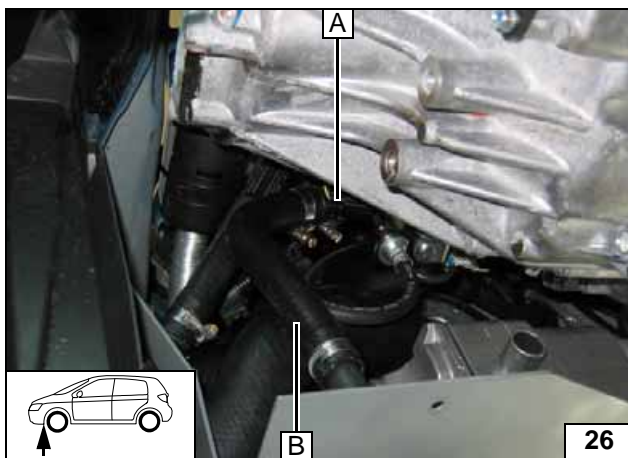

**Conne-
tion on
heater**

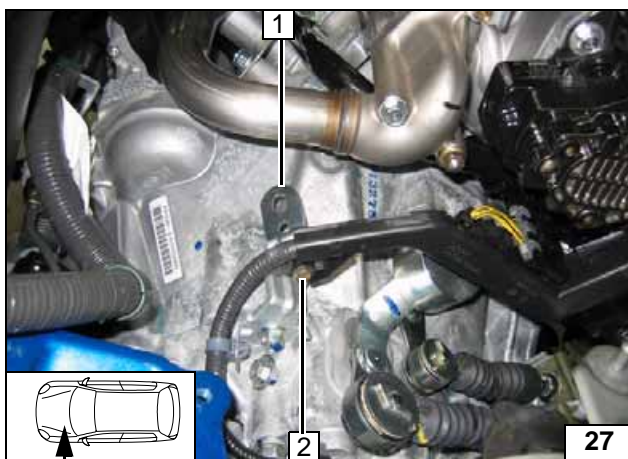

- 1 Angle bracket
- 2 Replace original vehicle bolt with M6x20 bolt

**Preparing
routing**

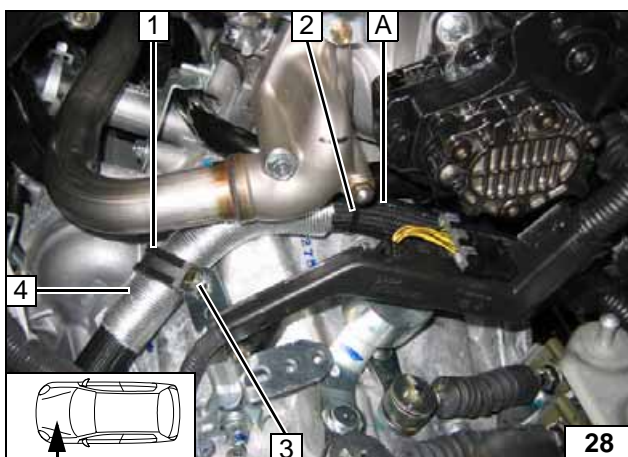

Ensure sufficient distance from neighbouring parts.



- 1 Rubber-coated p-clamp, 34 mm dia.
- 2 Cable tie
- 3 M6x20 bolt, M6 flanged nut
- 4 Position heat protection hose

**Routing in
engine
compart-
ment**

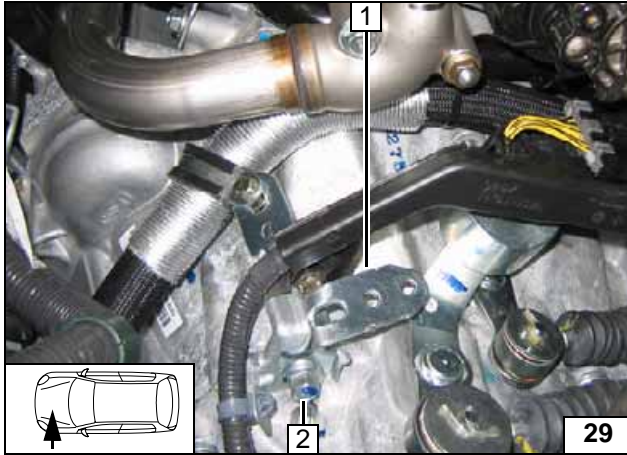

- 1 Perforated bracket
- 2 Original vehicle bolt

Preparing routing

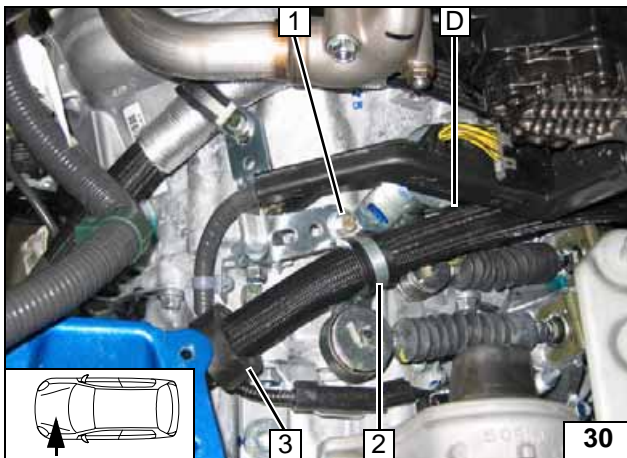

Ensure sufficient distance from neighbouring parts.

- 1 M6x20 bolt, M6 flanged nut
- 2 Rubber-coated p-clamp, 34 mm dia.
- 3 Black (sw) rubber isolator



Routing in engine compartment

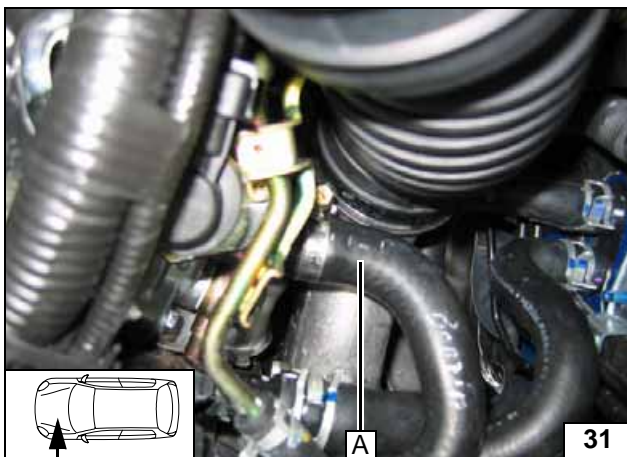

Fill the coolant hoses with coolant before connecting. Mount hose **A** with 180° elbow on engine outlet.



Connection to engine outlet

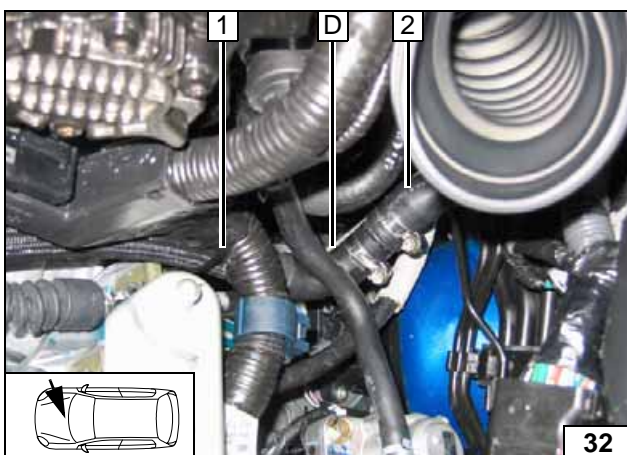

Mount hose **D** with 90° elbow on heat exchanger inlet **2**.

- 1 Cable tie



Connection on heat exchanger input



Fuel

CAUTION!

Open the vehicle's fuel tank cap, ventilate the tank and then re-close the tank lock.

Catch any fuel running off with an appropriate container.

Route fuel line and metering pump wiring harness so that they are protected against stone impact. Unless specified otherwise, always fasten using cable ties.

Mount the fuel line and wiring harness with rub protection on sharp edges.

WARNING!

The fuel line and wiring harness are routed to the metering pump as shown in the wiring harness routing diagram.

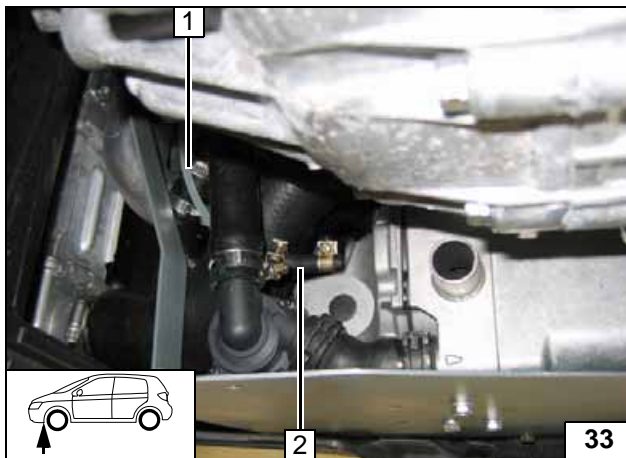

- 1 Fuel line
- 2 Hose section, 10 mm dia. hose clamp [2x]

Conne-
ction on
heater

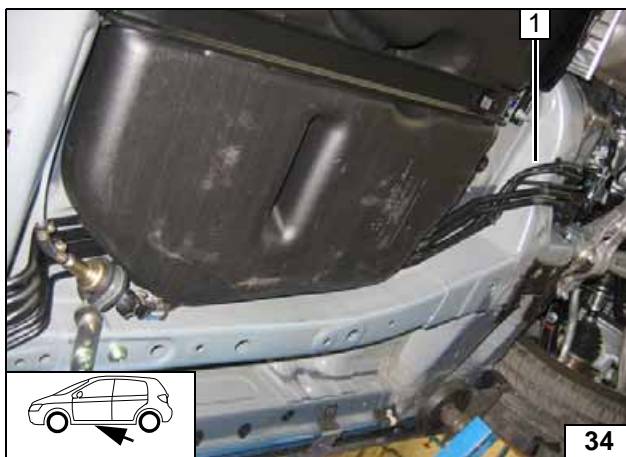

Route fuel line and wiring harness of metering pump together along original vehicle fuel lines to installation location of metering pump. Pull both into corrugated tube on underbody at position 1.



Routing
lines

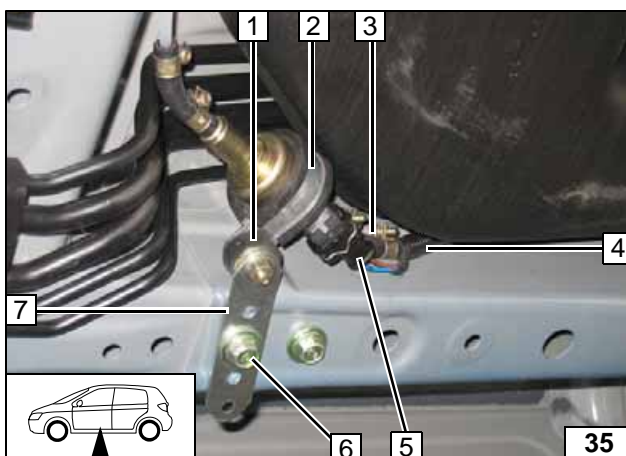

Ensure proper installation position of metering pump, see "Installation Instructions". Installation location on left behind vehicle fuel tank. Fuel line from heater on pressure side of metering pump [side with connector].

- 1 Silent block, flanged nut M6 [2x]
- 2 Rubber-coated p-clamp
- 3 Hose section, 10 mm dia. hose clamp [2x]
- 4 Corrugated tube
- 5 Wiring harness with connector
- 6 Original vehicle bolt, large diameter washer between perforated bracket 7 and vehicle



Installa-
tion loca-
tion of
metering
pump

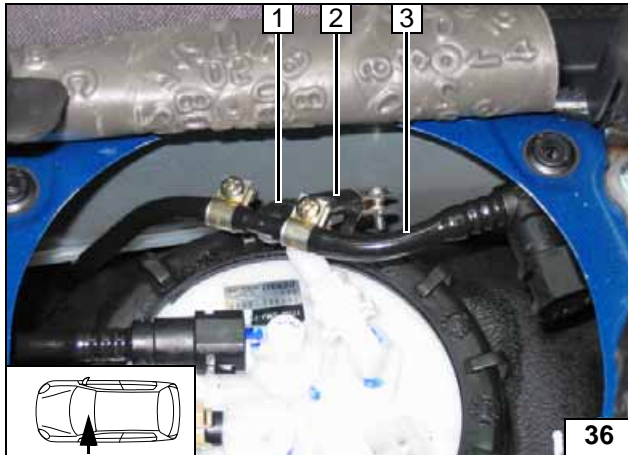

Cut off fuel supply line approx. 70 mm before coupling.

- 1 Fuel standpipe, 6x5x6
- 2 Hose section, 10 mm dia. hose clamp [2x], fuel line
- 3 Original vehicle fuel supply line



**Fuel ex-
traction**

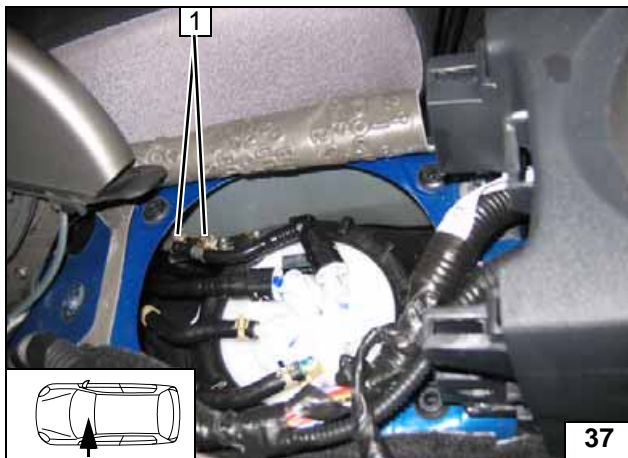

- 1 8mm dia. hose clamp [2x]

**Mounting
fuel stand-
pipe**



Fuel line from fuel standpipe **2** on intake side of metering pump [side without connector]. Check the position of the components; adjust if necessary. Check that they have freedom of movement.

- 1 Hose section, 10 mm dia. hose clamps [2x].



**Connec-
tion to me-
tering
pump**

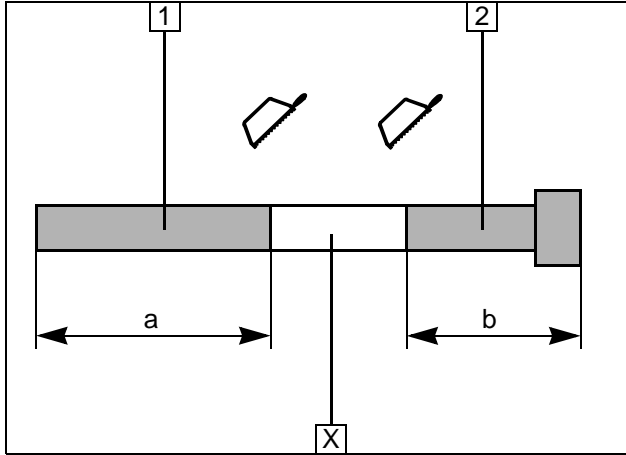
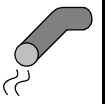

Exhaust gas

- 1 Exhaust pipe
a = 260mm
- 2 Exhaust end section
b = 210mm

Discard section X

Preparing exhaust pipe

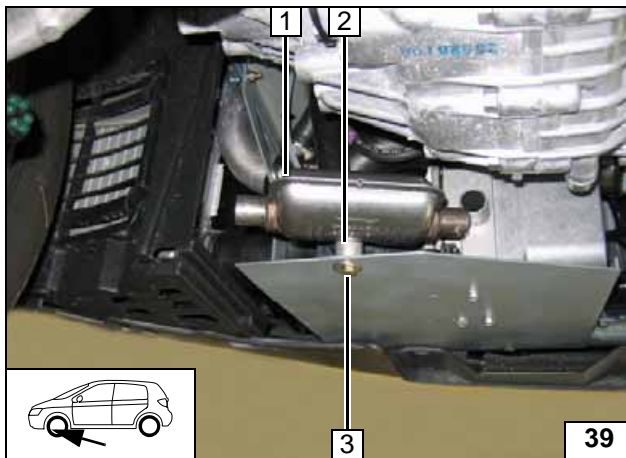

Eject screw bolt, tightening torque 10 Nm.

- 1 Silencer
- 2 30 mm long spacer
- 3 M6x50 bolt, large diameter washer, M6 flanged nut



Mounting silencer

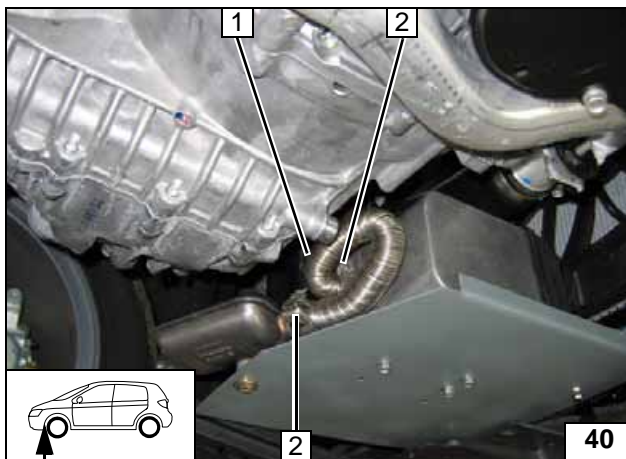

- 1 Exhaust pipe
- 2 Hose clamp [2x]

Mounting exhaust pipe

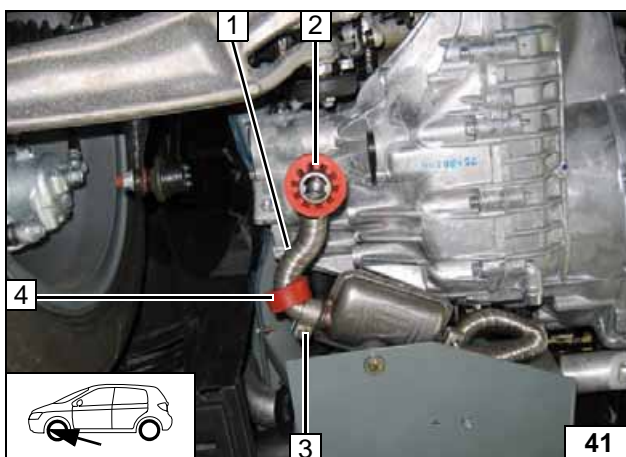

- 1 Exhaust end section
- 2 Red (rt) rubber isolator with groove
- 3 Hose clamp
- 4 Red (rt) rubber isolator

Mounting exhaust end section

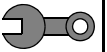

Final Work

WARNING!

Reassemble the disassembled components in reverse order.

Check all hoses, hose, spring and Caillau clamps, as well as all electrical connections for firm seating.

Secure all loose cables using cable ties.

Only use manufacturer-approved coolant.

Spray the heater components with anti-corrosion wax (Tectyl 100K, Order No. 111329).

- Connect the battery
- Fill and bleed the coolant circuit according to the vehicle manufacturer's specifications.
- Adjust digital timer, teach Telearstart transmitter
- Make settings on A/C control panel according to the "Operating Instructions for End Customer".
- Instruction signboard "Switch off parking heater before refilling" in the area of the filler neck
- For startup and function check, please see installation instructions

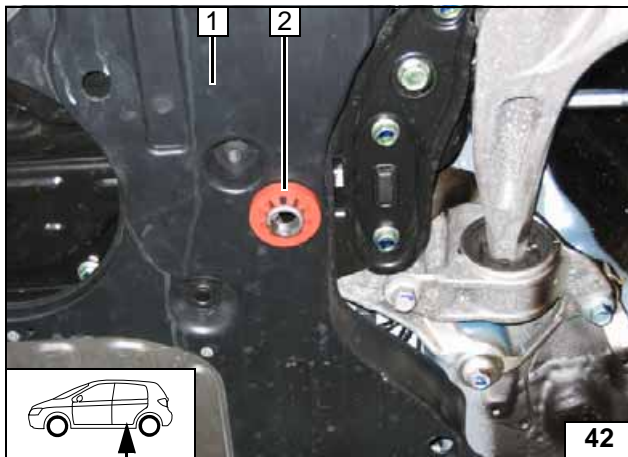

- 1 Underride protection
- 2 Drill out existing hole to 42 mm dia., red (rt) rubber isolator with groove

Mounting
rubber iso-
lator



Webasto AG
Postfach 80
D-82132 Stockdorf / Germany
National Hotline: 01805 93 22 78
(14 Cent aus dem deutschen Festnetz)
Hotfax: 0395 5592 353
Hotmail: technikcenter@webasto.com
<http://www.webasto.com>

Operating Instructions for End Customer

Please remove page and add to the vehicle operating instructions.

Note:

We recommend matching the heating time to the driving time.

Heating time = driving time

Example:

For a driving time of approx. 20 min. (in one direction), we recommend not exceeding a switch-on time of 20 min.

If vehicles have passenger compartment monitoring, it must be deactivated in addition to the vehicle settings for the heating operation.

Instructions for deactivation may be taken from the operating instructions of the vehicle.

Before parking the vehicle, make the following settings:

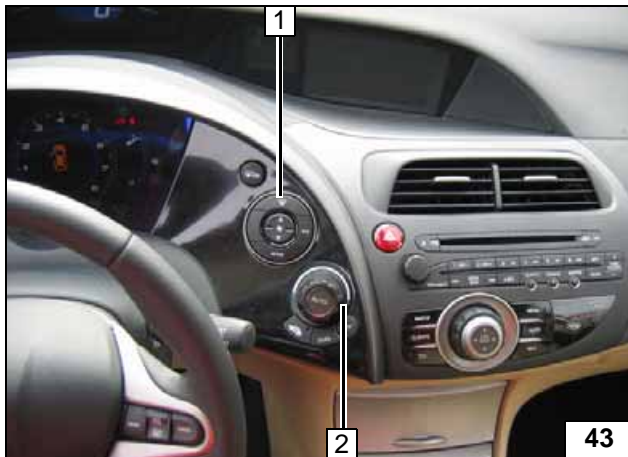

- 1 Air outlet to windscreen
- 2 Set temperature to "max."



**Automatic
air-conditioning**