

Water Heater



Thermo Top E Parking Heater

00 0003

Thermo Top C Parking Heater

00 0002

Installation documentation

Peugeot 207 / 207 SW / 207 CC

Petrol and Diesel
from Model Year 2006
Left-hand drive vehicle
Manual transmission



WARNING!

Hazard warning:

Incorrect installation or repair of Webasto heating systems may cause a fire or result in the emission of carbon monoxide, which can be fatal. Serious or fatal injuries can be caused as a result.



Specialist company training, technical documentation, specialised tools and equipment are required to install and repair Webasto heating and cooling systems. Only original Webasto parts must be used. For this, also see the catalog of air and water heater accessories from Webasto.

NEVER attempt to install or repair Webasto heating or cooling systems if you have not successfully completed the company training and thereby acquired the required technical skills, or if you do not have access to the required technical documentation, tools and equipment needed to carry out correct installation and repairs.

ALWAYS follow all Webasto installation and repair instructions and observe all warnings.

The initial startup is to be executed with the Webasto Thermo Test Diagnosis.

Webasto does not accept any liability for defects and damage that are attributable to installation by untrained staff.

Peugeot 207 / 207 SW / 207 CC

Table of Contents

Validity	2	Preparing heater	17
Heater/Installation Kit	3	Preparing installation location	18
Foreword	3	Installing heater	19
General Instructions	3	Petrol coolant circuit	21
Special Tools	3	Diesel coolant circuit	26
Explanatory Notes on Document	4	Combustion air	29
Preliminary Work	5	Fuel	30
Heater installation location	5	Exhaust gas	33
Automatic air-conditioning	6	Final Work	35
Electrical system	9	Operating Instructions for End Customer	37
Fan control for manual air conditioning	10		
Automatic air-conditioning fan control	12		
Remote option (Telestart)	16		

Validity

Manufacturer	Model	Type	EG-BE No. / ABE
Peugeot	W	207	e2 * 2001 / 116 * 0340

Engine type	Engine model	Output in kW	Displacement in cm ³
KFU	Petrol	65	1360
NFU	Petrol	80	1587
5FW	Petrol	88	1598
5FX	Petrol	110	1598
5FY	Petrol	128	1598
9HV	Diesel	66	1560
9HX	Diesel	66	1560
9HY	Diesel	80	1560
9 Hz	Diesel	80	1560

Vehicle and engine types, equipment variants and national specifications not listed in this installation documentation have not been tested. However, installation according to this installation documentation may be possible.

The installation location of a digital timer and summer/winter switch should be confirmed with the end customer before installation.

Peugeot 207 / 207 SW / 207 CC

Heater/Installation Kit

Quantity	Designation	Order No.:
1	Retail accessories of <i>Thermo Top C / E</i>	See price list
1	Heater control	See price list

Also required with manual air conditioning:

Quantity	Designation	Order No.:
1	Installation kit for Peugeot 207 / 207 SW / 207 CC Petrol and Diesel with manual air conditioning	1311147C

Also required with automatic air-conditioning:

Quantity	Designation	Order No.:
1	Installation kit for Peugeot 207 / 207 SW / 207 CC Petrol and Diesel Automatic air-conditioning	1311169D

Heater recommended for the respective vehicle class:

Vehicle	Heater
Compact car	Thermo Top E
Mid-size car, estate car	Thermo Top C

The selection of the heater is based on the passenger compartment size of the vehicle and the level of comfort required by the customer.



Foreword

This installation documentation applies to the vehicles Peugeot 207 / 207 SW / 207 CC with Petrol and Diesel engine - for validity, see page 2 - from model year 2006 and later, assuming technical modifications to the vehicle do not affect installation, any liability claims excluded. Depending on the vehicle version and equipment, modifications may be necessary during installation with respect to this installation documentation.

However, the stipulations in this "installation documentation", the "operating instructions" and the "installation instructions" for the *Thermo Top C/E* must always be observed.

The corresponding rules of technology and any information from the vehicle manufacturer should be observed during the installation work.

General Instructions

Installation should be carried out according to the general, standard rules of technology. Unless specified otherwise, fasten hoses, lines and wiring harnesses to original vehicle lines and wiring harnesses using cable ties.

Sharp edges must be provided with rub protection (cut-open fuel hose).

Spray unfinished body areas, e.g. drilled holes, with anti-corrosion wax (Tectyl 100K, Order No. 111329). While installing an IPCU, the corresponding settings must be checked or adjusted before the installation.

Special Tools

- Torque wrench for 2.0 - 10 Nm
- Hose clamping pliers
- Metric thread-setter kit

Explanatory Notes on Document

You will find an identification mark on the outside top right corner of the page in question to provide you with a quick overview of the individual working steps.

Mechanical system

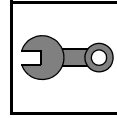

Electrical system

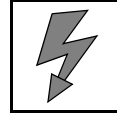

Coolant circuit

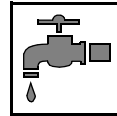

Fuel

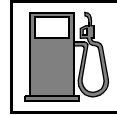

Exhaust gas

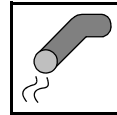

Combustion air

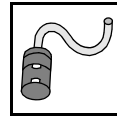

Special features are highlighted using the following symbols:



Specific risk of injury or fatal accidents.



Specific risk of damage to components.



Specific risk of fire or explosion.



Reference to general installation instructions of Webasto components or to the manufacturer's vehicle-specific documents.



Reference to a special technical feature.

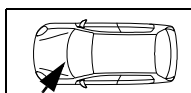
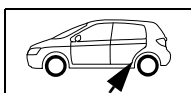

The arrow in the vehicle icon indicates the position on the vehicle and the viewing angle.

Preliminary Work

WARNING!

- Disconnect the battery.
- Depressurise the cooling system.
- Copy the factory number from the original type label to the duplicate type label.
- Remove years that do not apply from the duplicate label.
- Attach the duplicate label (type label) in the appropriate place.
- Remove the battery completely.
- Remove the air filter together with the intake hose.
- Open the fuel tank cap, ventilate the tank.
- Close the fuel tank cap again.
- Remove the underride protection on the left.
- Remove the rear bench seat and backrest.
- Open the tank-fitting service lid
- Remove the fuel-tank sending unit in accordance with manufacturer's instructions.
- Remove the trim of the centre tunnel in the left-hand footwell
- Remove the lower instrument panel trim on the left.
- Remove the A/C control panel.

Please remove page 35 "Operating instructions for the end customer" and add this to the vehicle operating instructions.

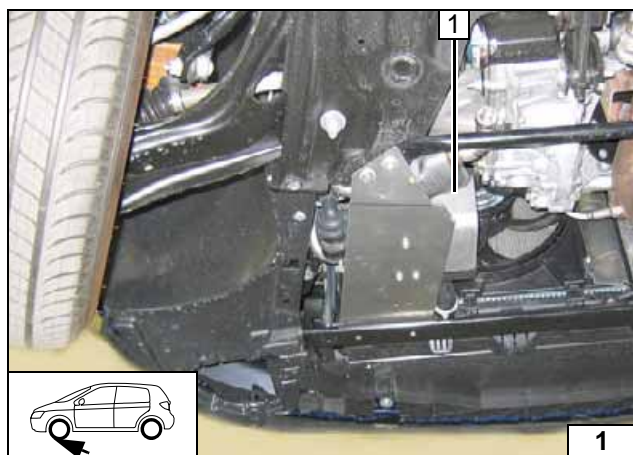

Heater installation location

1 Heater

Installation location

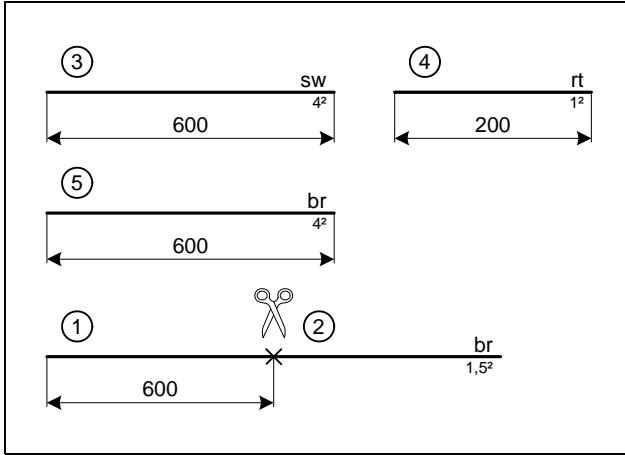

Preparing electrical system

Manual air conditioning

Wire sections 1 - 5 for connection K3.1 relay.



Cutting wires to length

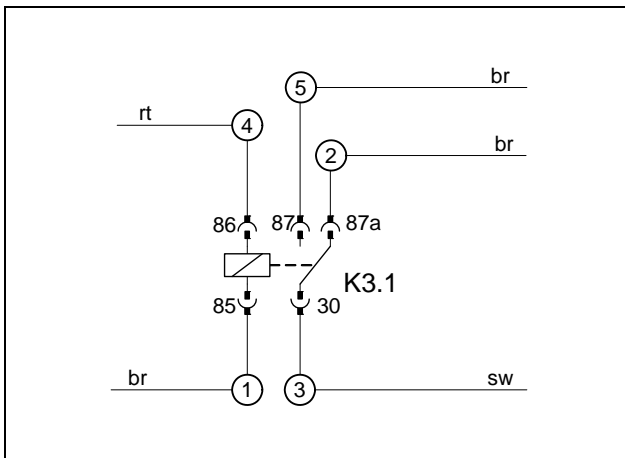

Produce connections as shown in wiring diagram.



Premounting K3 relay

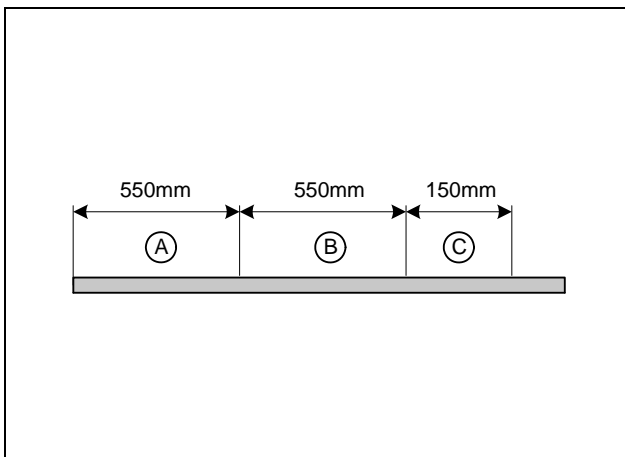

Pull wire section 4 into protective sleeving C, wire section 1 into protective sleeving A and wire section 2, 3, 5 into protective sleeving B.



Cutting protective sleeving to length

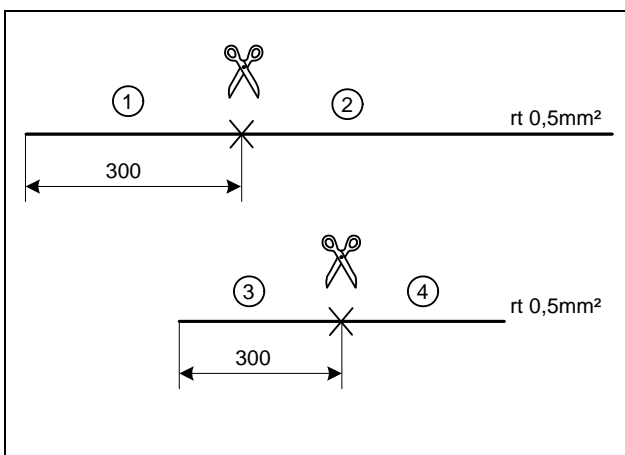

Automatic air-conditioning

Wire sections 1, 3, and 4 for connection K3.1 relay.

Wire section 2 for connecting K3.2 relay.



Cutting wires to length

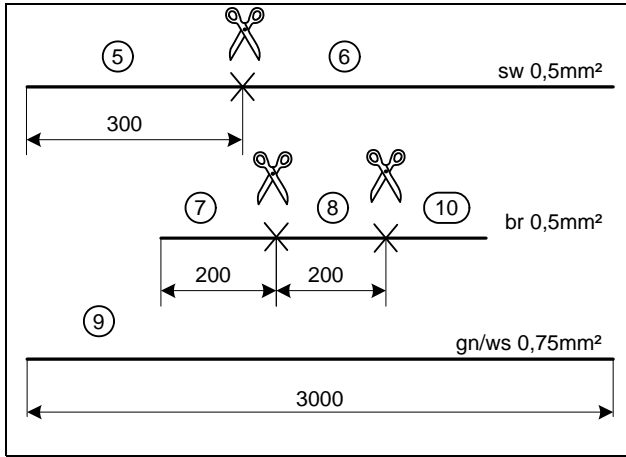

Wire sections **5**, **7**, and **10** for connection K3.1 relay.
 Wire sections **6** and **8** for connection IPCU.
 Wire section **9** for connection K3.

Cutting wires to length

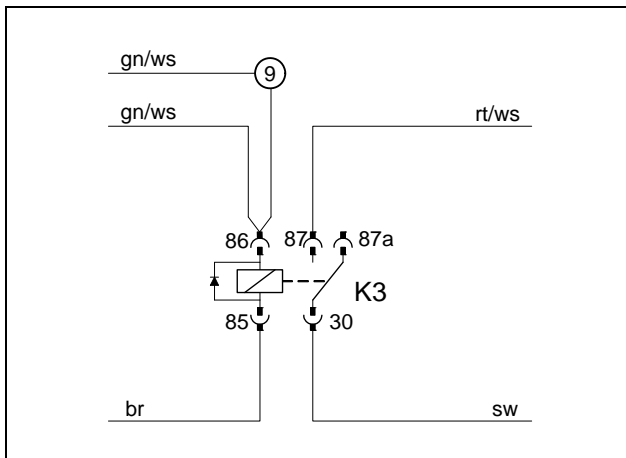

Produce connections as shown in wiring diagram.
 Install wire section **9** in protective sleeving provided.



Premounting K3 relay

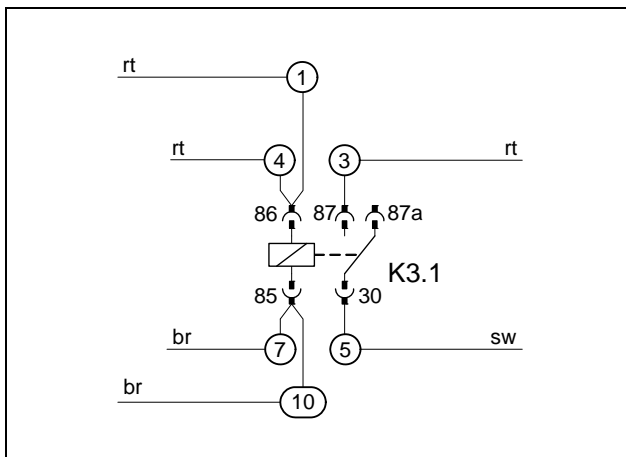

Produce connections as shown in wiring diagram.



Premounting K3.1 relay

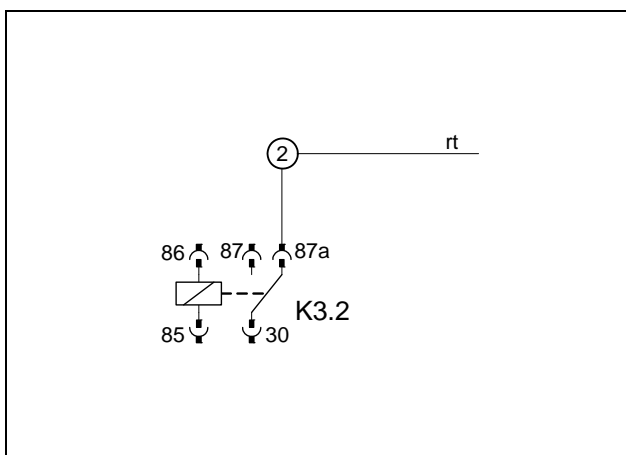

Produce connections as shown in wiring diagram.



Premounting K3.2 relay

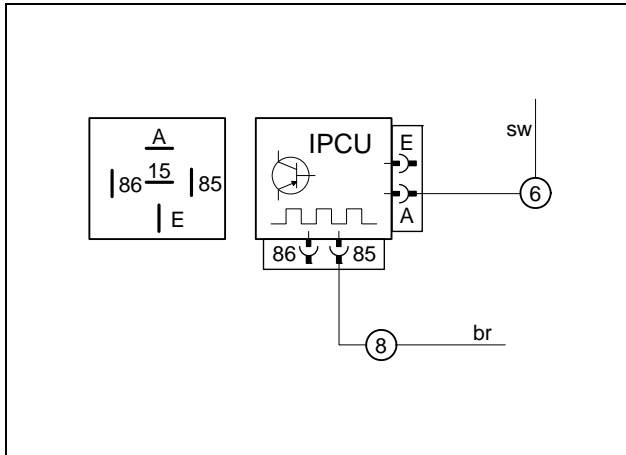

Produce connections as shown in wiring diagram.
The IPCU included in the kit is pre-programmed with the following settings:

Duty cycle: 75%
Frequency: 2000Hz
Voltage: 10V
Function: Low-side

The settings are to be checked during start-up of heater, and adjusted if necessary.

Premounting IPCU



Electrical system

Wiring harness pass through

- 1 18 mm dia. hole, included protective rubber plug

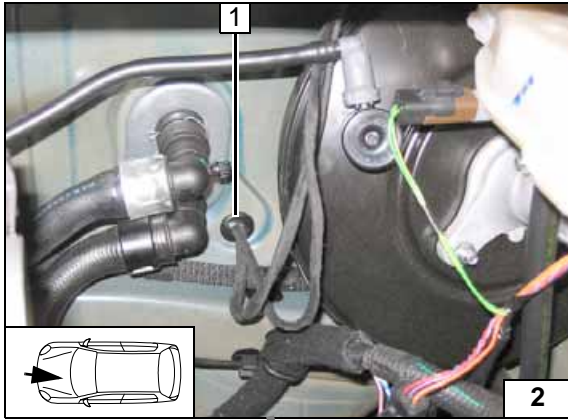

Summer/winter switch option

- 1 Summer/winter switch, drilled hole 12 mm dia.

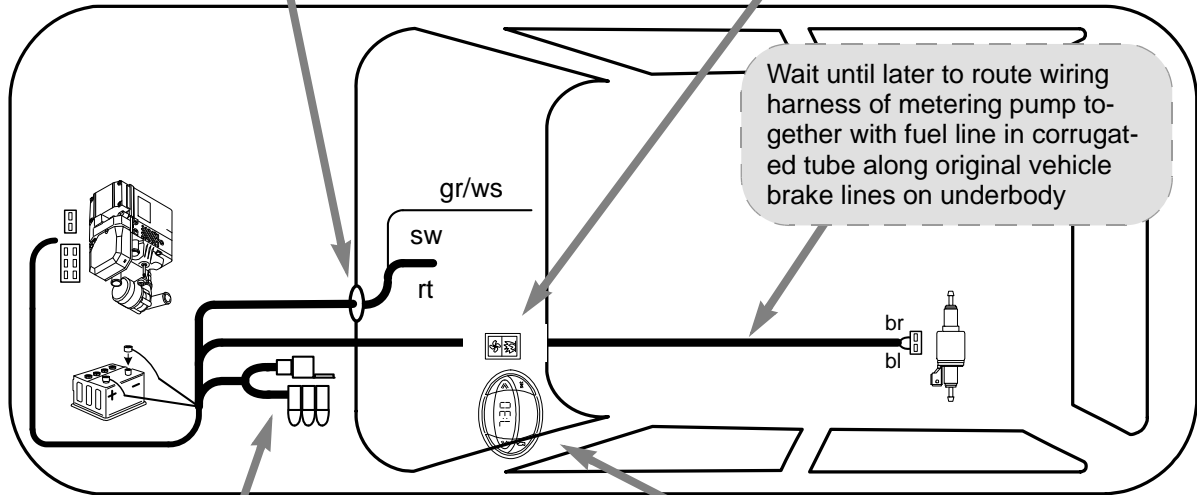
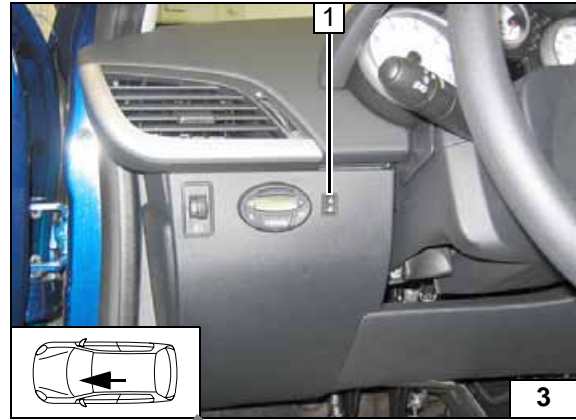

Wiring harness routing diagram

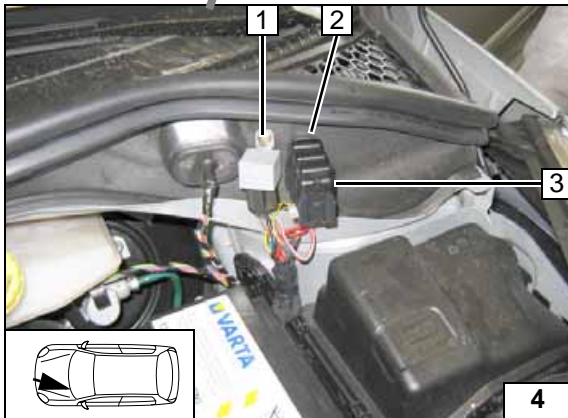

Fuse holder, K3 relay

- 1 K3 relay, 5.5x13 bolt, hole 4.5 mm dia.
- 2 Retaining plate of fuse holder, 5.5x13 bolt, 4.5 mm dia. hole
- 3 Fuse holder

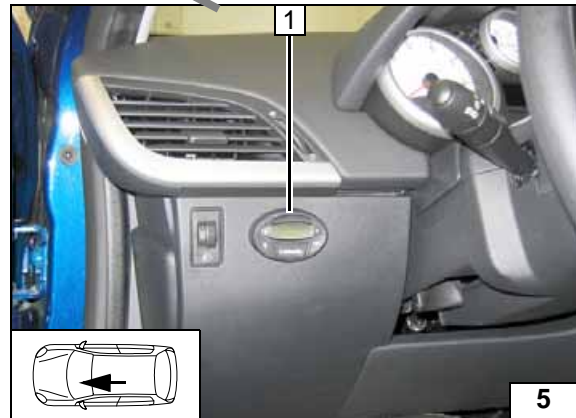

Digital timer

- 1 Digital timer

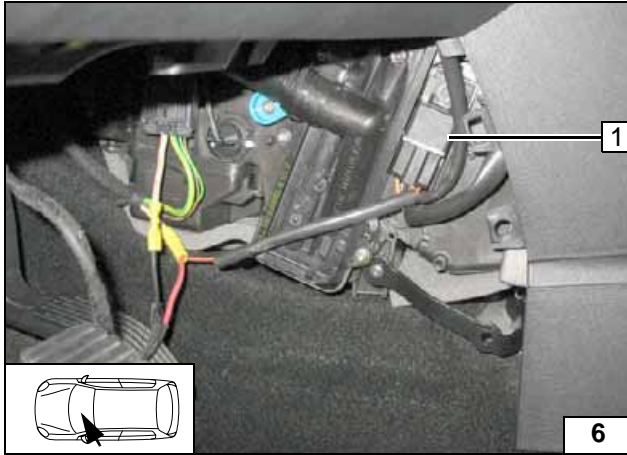

Fan control for manual air conditioning

Fasten additional relay K3.1 1 with installation strap.



Mounting K3.1

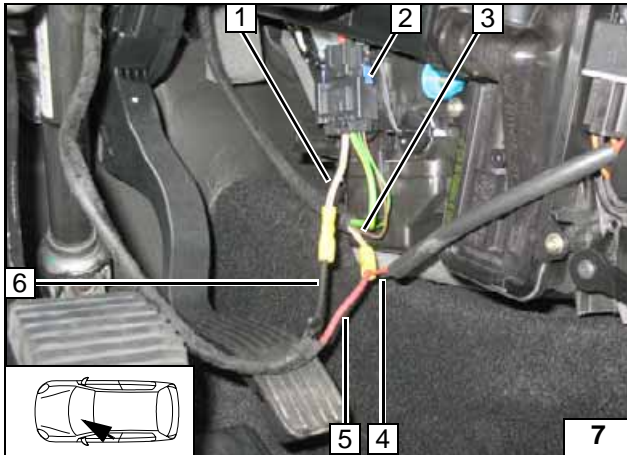

Connection to 6-pin connector IC 26 2 from wiring harness of fan motor. Produce connections as shown in wiring diagram.



- 1 White (ws) wire of connector IC 26
- 3 White (ws) wire of PSF 1 connector 2V NR Pin 2
- 4 Red (rt) wire to K3.1/86
- 5 Red (rt) wire from K3/87a
- 6 Black (sw) wire from K3/30

Connect-ing fan motor

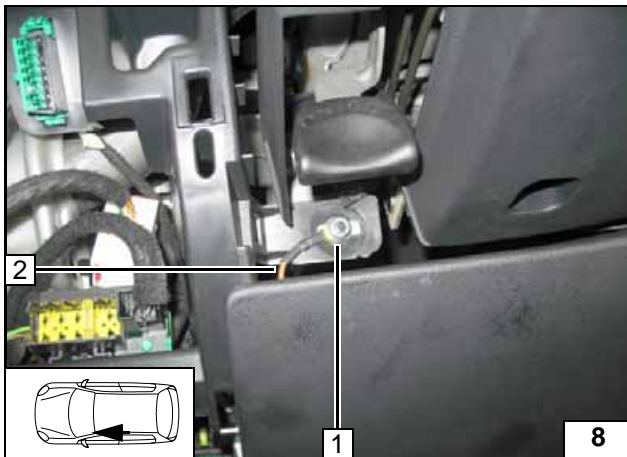

Make connection with the help of attached 6 mm dia. cable lug.



- 1 Original vehicle earth point
- 2 Brown (br) wire K3.1/85

Earth connection of K3.1

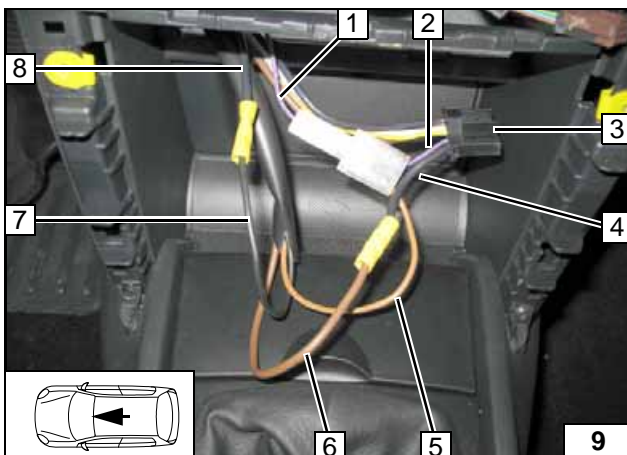

Connection on connector 8V NR 3 from fan switch/A/C control panel. Produce connections as shown in wiring diagram.



- 1 Violet (vi) wire of connector 4V NR, Pin 3
- 2 Violet (vi) wire of connector 8V NR, Pin 3
- 4 Black (sw) wire of connector 8V NR, Pin 1
- 5 Brown (br) wire of K3.1/87a
- 6 Brown (br) wire K3.1/87
- 7 Black (sw) wire K3.1/30
- 8 Black (sw) wire of earth point

Connect-ing A/C control panel

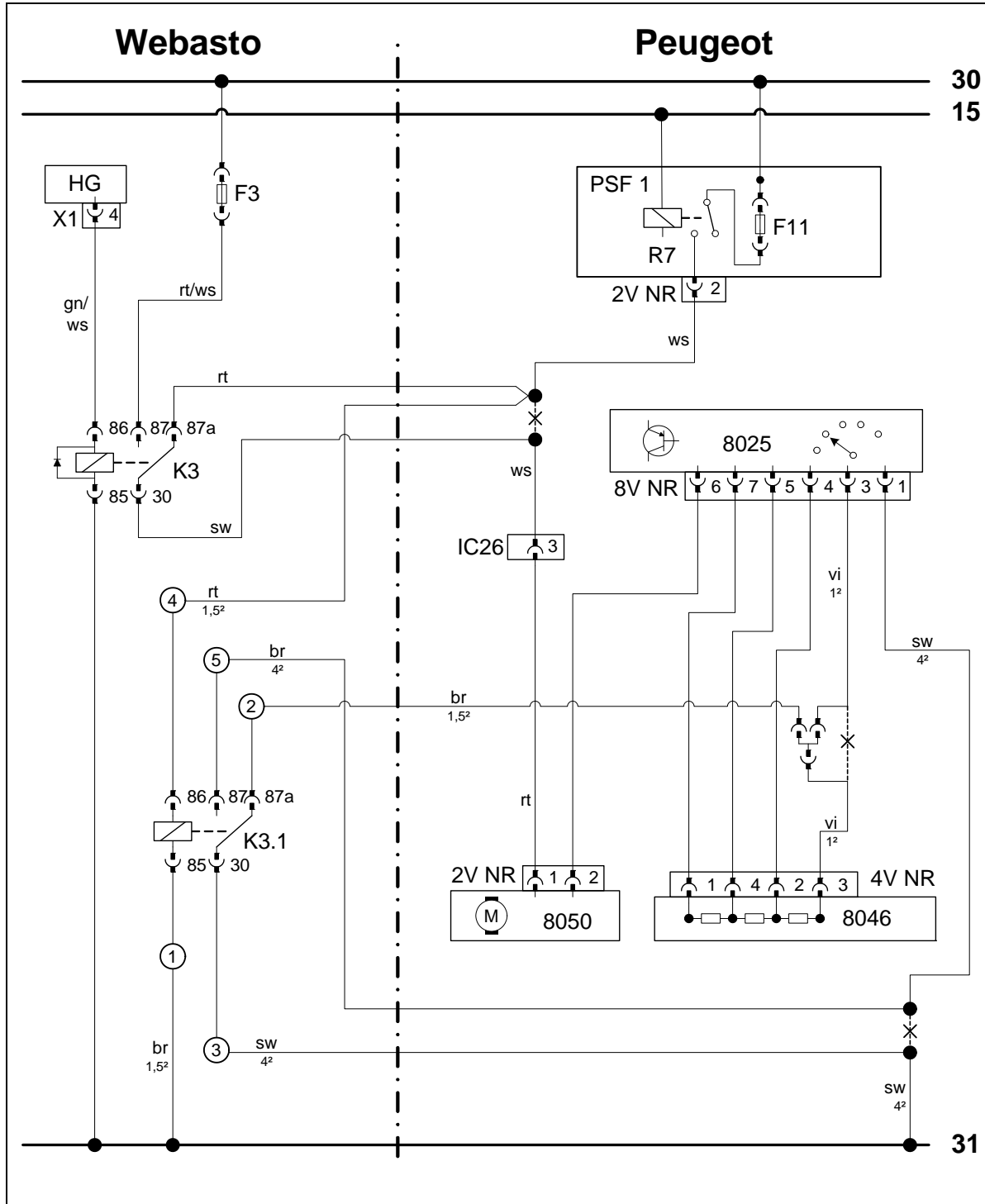

Wiring diagram for manual air conditioning

Webasto components		Vehicle components		Colours and symbols	
HG	TT-C/E Heater	8050	Fan motor	rt	red
X1	6-pin connector	8025	Fan switch/A/C control panel	ws	white
F3	25 A fuse			sw	black
K3	Fan relay	8046	Resistor group	br	brown
K3.1	Additional relay	PSF1	Main power supply	gn	green
		IC26	6-pin connector	vi	violet
		2V NR	2-pin connector		
		4V NR	4-pin connector		
		8V NR	8-pin connector		
				X	Cutting point
				Wiring colours may vary.	

Legend

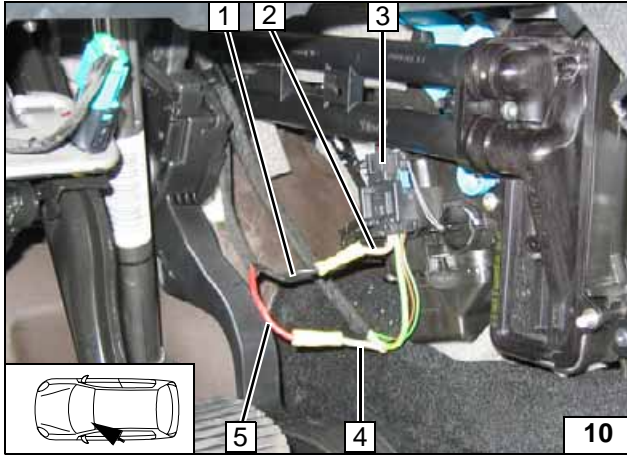

Automatic air-conditioning fan control

Connection to 6-pin connector IC 26 3 from wiring harness of fan motor. Produce connections as shown in wiring diagram.

- 1 Black (sw) wire from K3/30
- 2 White (ws) wire of connector IC 26, Pin 3
- 4 White (ws) wire of PSF 1 connector 2V NR Pin 2
- 5 Red (rt) wire from K3/87a



**Connect-
ing fan mo-
tor**

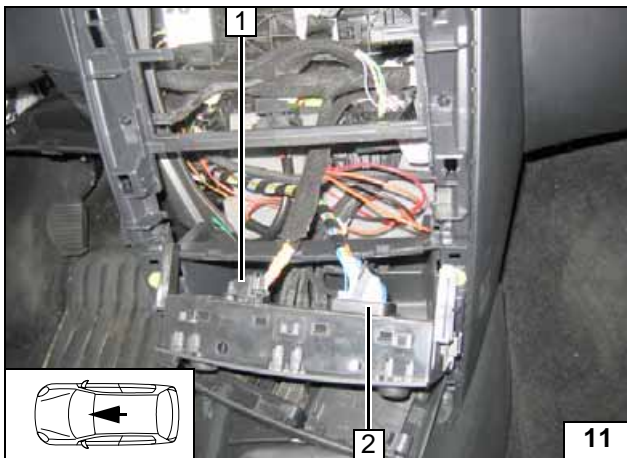

- 1 Connector 18V NR
- 2 Connector 40V BE

**A/C control
panel**

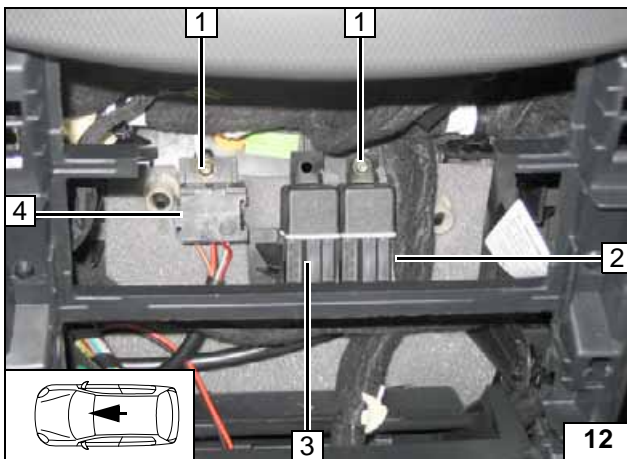

Connect green/white (gn/ws) wire from K3/86 to IPCU/86. Connect red (rt) wire from K3.1/86 to K3.2/86. Connect brown (br) wire from K3.1/85 to K3.2/85. Bond K3.2 3 to K3.1 2 with adhesive tape.

- 1 Original vehicle bolt [2x]
- 4 IPCU socket



**Mounting
K3.1 and
IPCU**

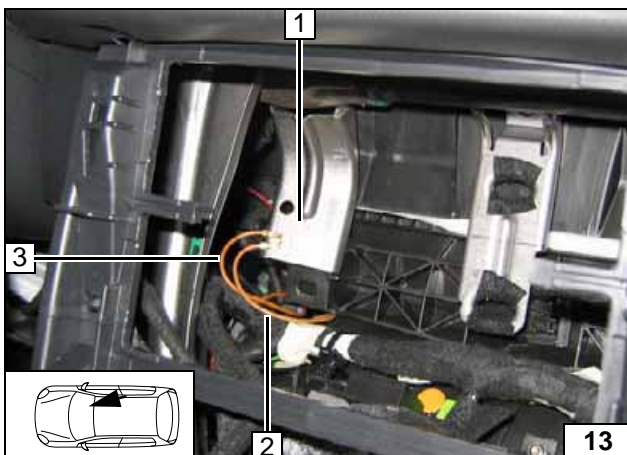

Produce connection with included cable lugs.

- 1 Original vehicle bolt
- 2 Brown (br) wire K3.1/85
- 3 Brown (br) wire of IPCU/85



**Connect-
ing earth
for IPCU,
K3.1 and
K3.2**

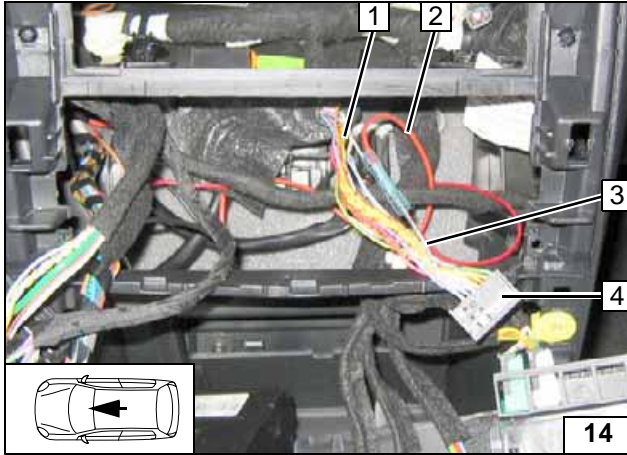

Connection on 18-pin connector 18V NR 4 from A/C control panel. Produce connection as shown in wiring diagram.

- 1 Gray (gr) wire of terminal 15
- 2 Red (rt) wire to K3.1/86
- 3 Gray (gr) wire to connector 18V NR



**Connect-
ing termi-
nal 15 for
K3.1 and
IPCU**

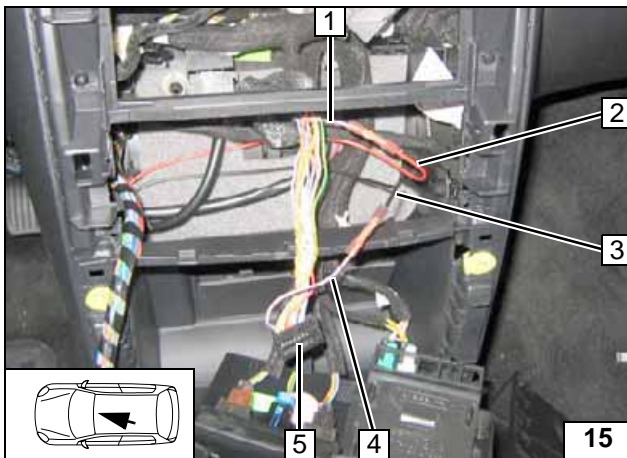

Connection on 18-pin connector 18V NR 5 from A/C control panel. Produce connections as shown in wiring diagram.

- 1 Pink (ro) wire of BSI1 connector 10V NR, Pin 6
- 2 Red (rt) wire to K3.1/87
- 3 Black (sw) wire K3.1/30
- 4 Pink (ro) wire of connector 18V NR, Pin 18



**Connect-
ing relay
K3.1**

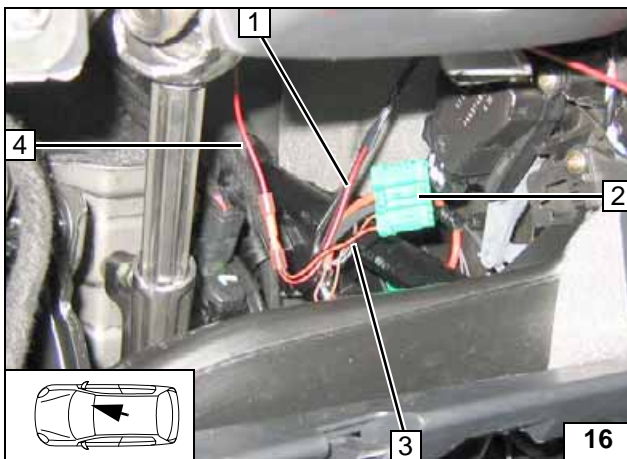

Variant 1

Connection on green (gn) 6-pin connector 6V VE 2 from fan controller. Produce connections as shown in wiring diagram.

- 1 8080 mm long red (rt) wire of connector 40V BE, Pin 39
- 3 Red (rt) wire of connector 6V VE, Pin 6
- 4 Red (rt) wire of K3.2/87a



**Connect-
ing fan
controller**

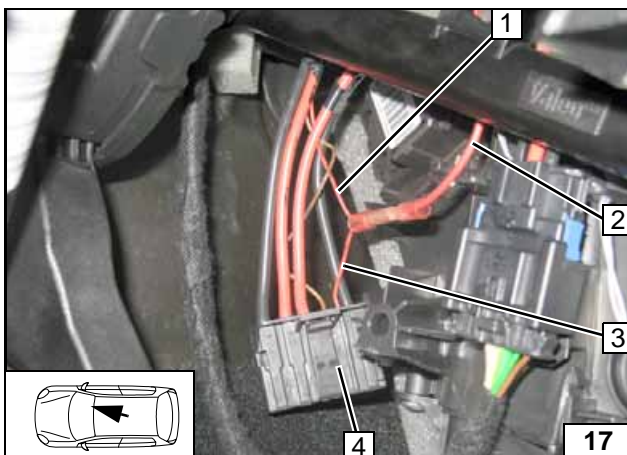

Variant 2

Connection on black (sw) 6-pin connector 6V NR 4 from fan controller. Produce connections as shown in wiring diagram.

- 1 8080 mm long red (rt) wire of connector 40V BE, Pin 39
- 2 Red (rt) wire of K3.2/87a
- 3 Red (rt) wire of connector 6V NR, Pin 5



**Connect-
ing fan
controller**



Wiring diagram of automatic air-conditioning Variant 1

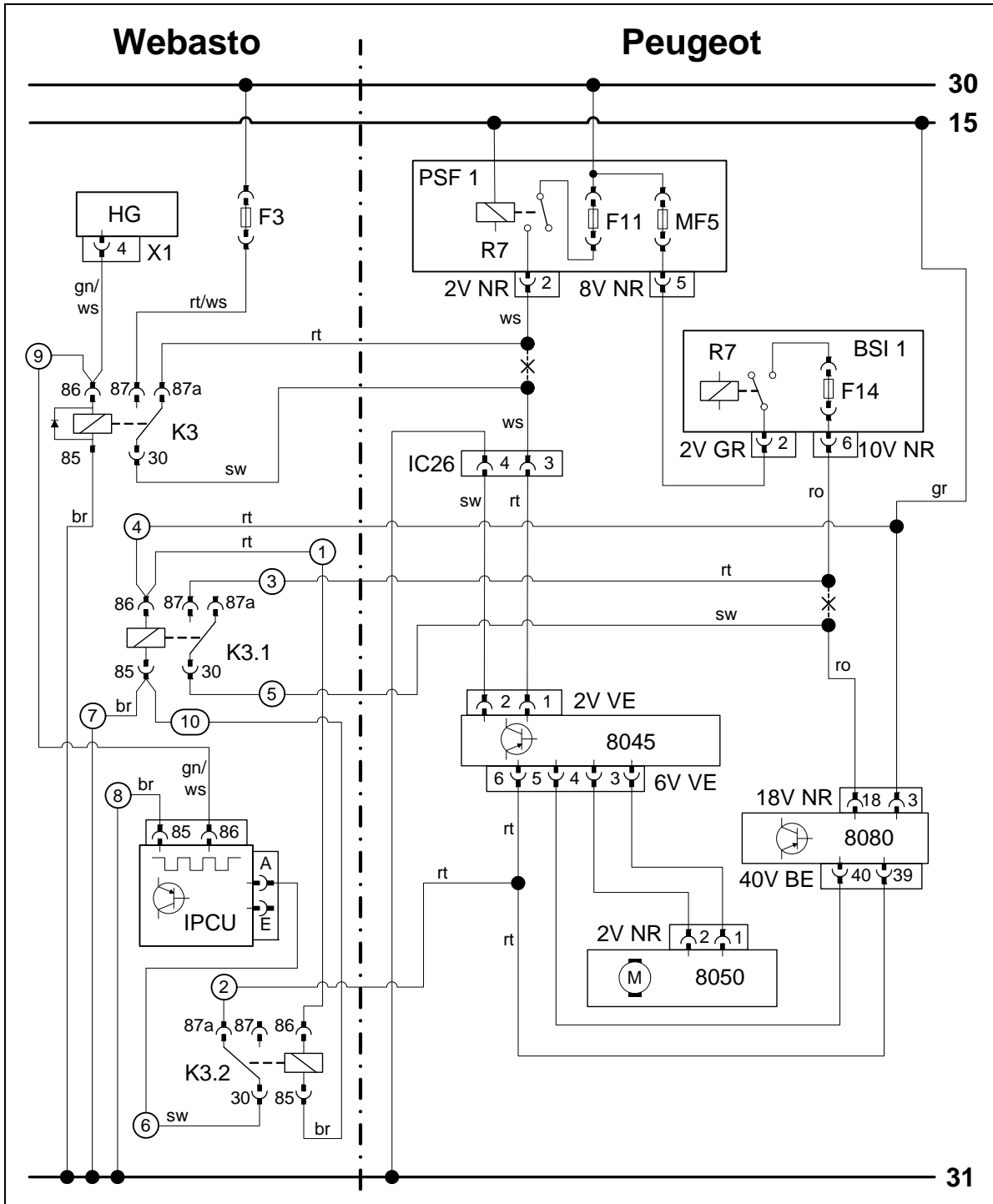

Wiring diagram

Webasto components		Vehicle components		Colours and symbols	
HG	TT-C/E Heater	8050	Fan motor	rt	red
X1	6-pin connector	PSF1	Main power supply	ws	white
F3	Fuse	8045	Fan controller	sw	black
K3	Fan relay	8080	A/C control panel	br	brown
K3.1	Additional relay	BSI1	Central electrical box for passenger compartment	gn	green
K3.2	Additional relay	IC 26	6-pin connector	ro	pink
IPCU	Pulse width modulator			gr	gray
				X	Cutting point
					Wiring colours may vary.

Legend



Wiring diagram of automatic air-conditioning Variant 2

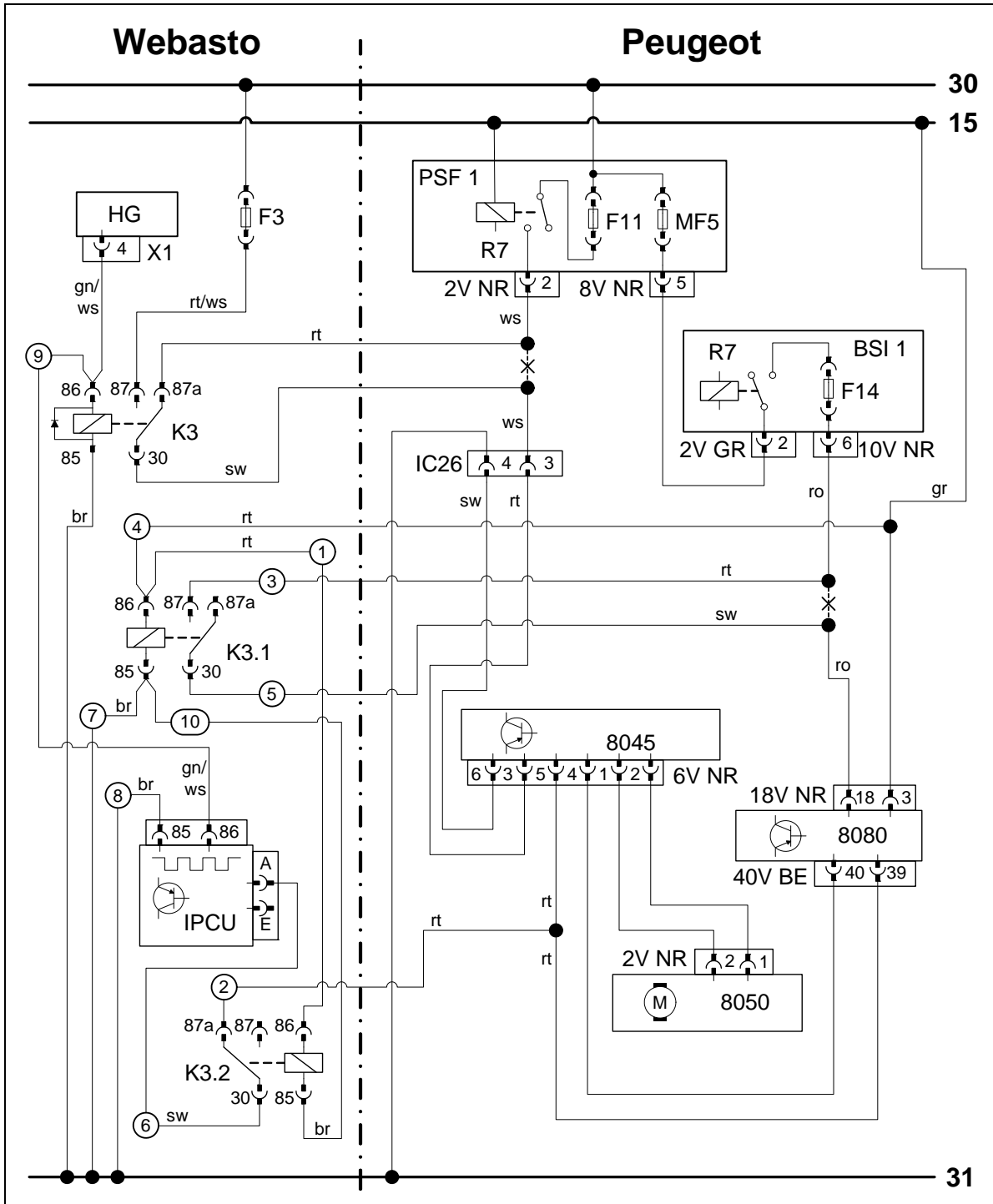

Wiring diagram

Webasto components		Vehicle components		Colours and symbols	
HG	TT-C/E Heater	8050	Fan motor	rt	red
X1	6-pin connector	PSF1	Main power supply	ws	white
F3	Fuse	8045	Fan controller	sw	black
K3	Fan relay	8080	A/C control panel	br	brown
K3.1	Additional relay	BSI1	Central electrical box for passenger compartment	gn	green
K3.2	Additional relay	IC 26	6-pin connector	ro	pink
IPCU	Pulse width modulator			gr	gray
				X	Cutting point
					Wiring colours may vary.

Legend

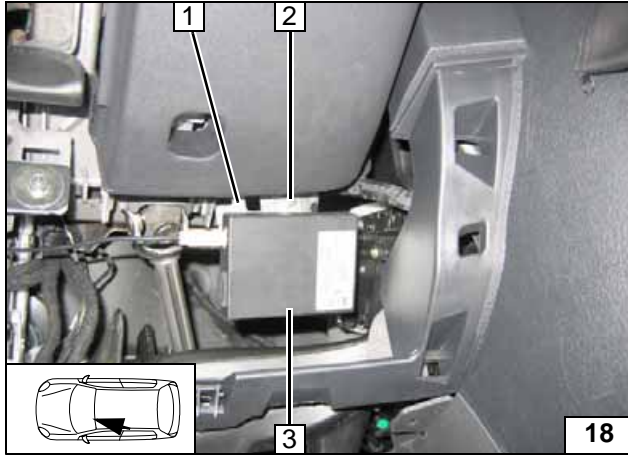

Remote option (Telestart)

- 1 Bracket, drill out hole to 7 mm dia.
- 2 Original vehicle bolt
- 3 Receiver



Mounting receiver

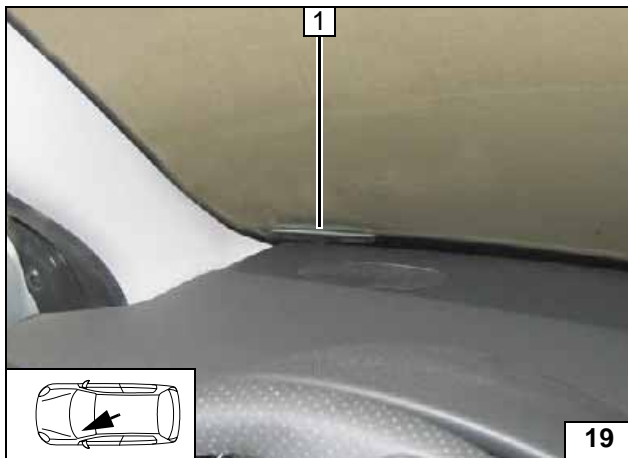

- 1 Antenna

Mounting antenna

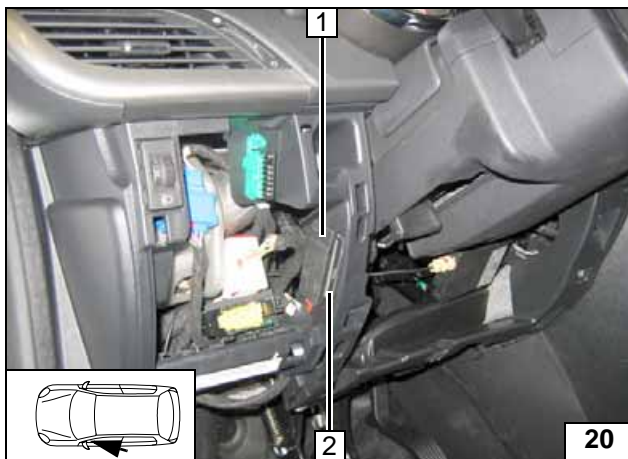

Temperature sensor for HTM100 only

- 1 Temperature sensor
- 2 Installation strap

Mounting temperature sensor

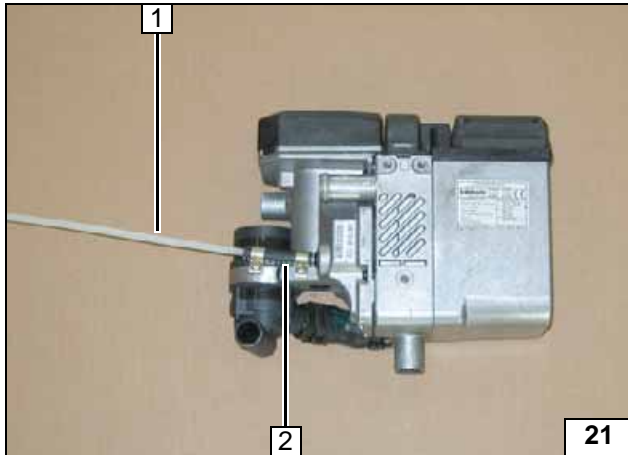
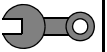

Preparing heater

KFU/NFU

- 1 Fuel line
- 2 Hose section, 10 mm dia. hose clamp [2x]

Mounting fuel line

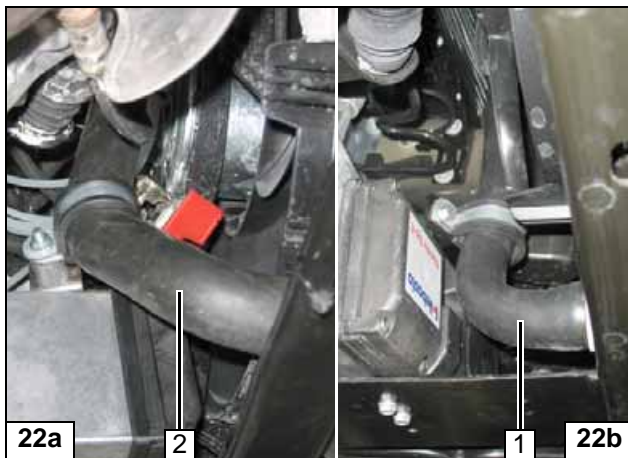

5FW/X/Y

The premounting of the strut differs according to the vehicle-specific routing of the coolant hose. One differentiates between variants **A** and **B**, depending on the equipment.

- 1 Coolant hose variant **B**
- 2 Coolant hose variant **A**



Preparing heater

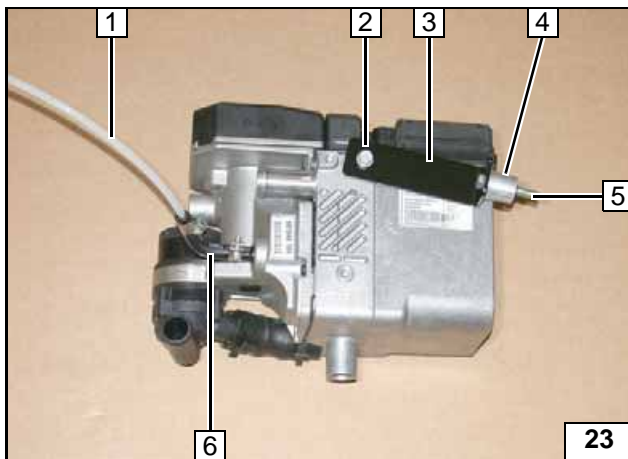

Variant A

Eجت screw bolt, tightening torque 10 Nm.

- 1 Fuel line
- 2 Eجت screw
- 3 Strut
- 4 20 mm spacer sleeve
- 5 M6x40 bolt, pin lock
- 6 90° moulded hose, hose clamp 10 mm dia. [2x]



Preparing heater

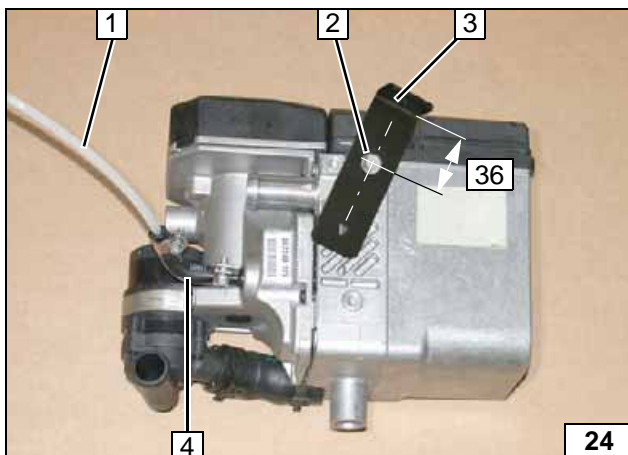

Variant B

7 mm dia. hole at position **2** in strut **3**.
Eجت screw bolt, tightening torque 10 Nm.

- 1 Fuel line
- 2 Eجت screw
- 4 90° moulded hose, hose clamp 10 mm dia. [2x]



Preparing heater

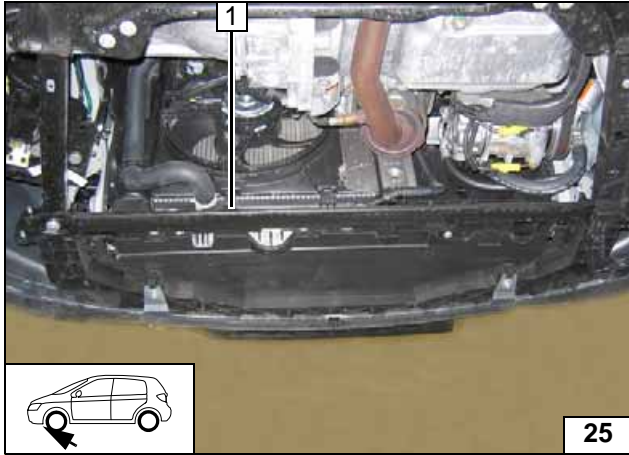
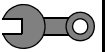

Preparing installation location

1 Remove original vehicle strut

Removing strut

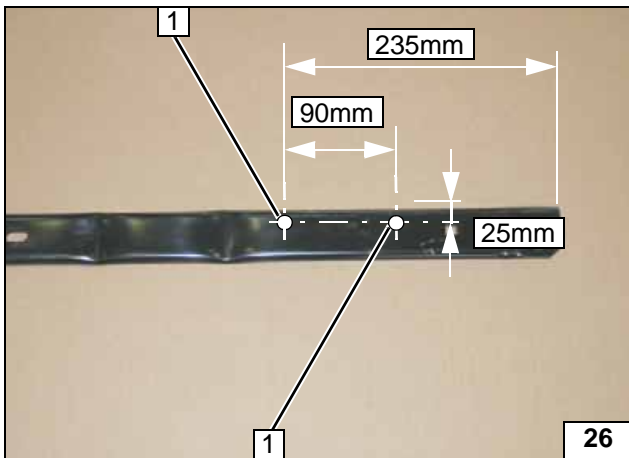

Copy hole pattern as shown and drill 9.1 mm dia. holes [2x] in strut at pos. 1.



Copying hole pattern

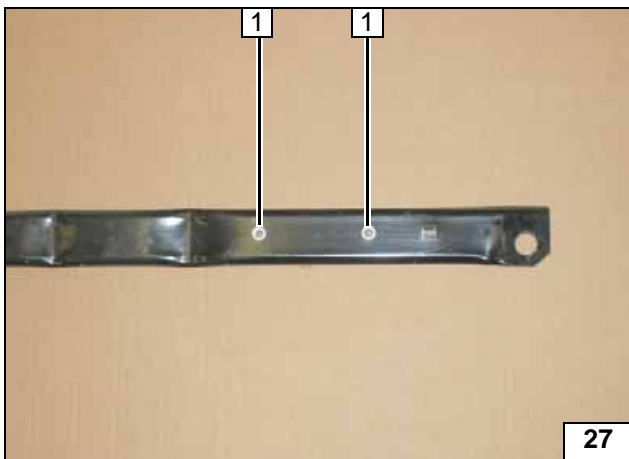

1 M6 rivet nut [2x]

Installing rivet nuts

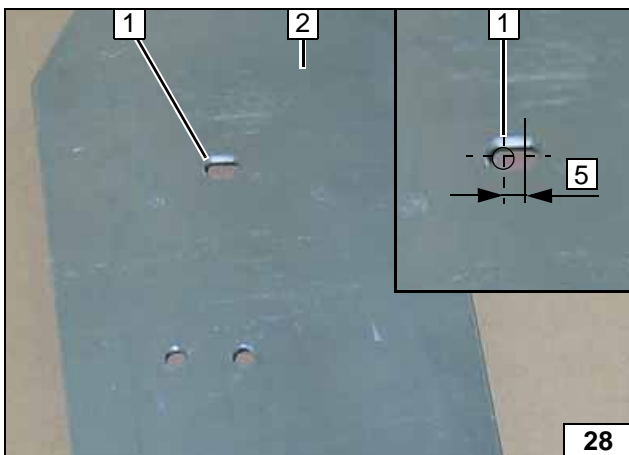

Expand hole at position 1 to oblong hole.

2 Bracket



Preparing bracket

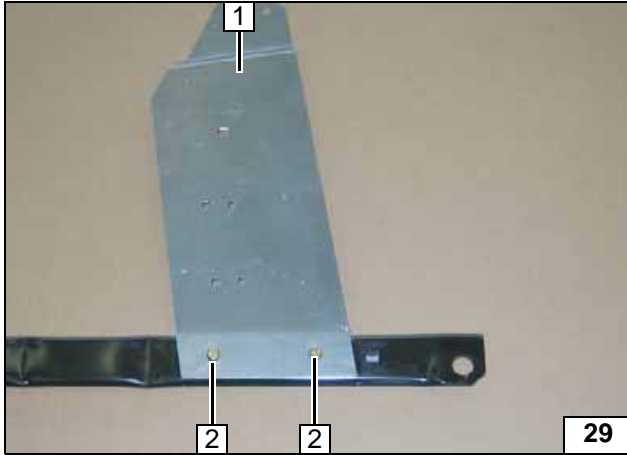
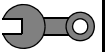

- 1 Loosely mount bracket
- 2 M6x16 bolt [2x], spring lockwasher [2x]

Premounting bracket



- 1 Tighten M6x16 bolt with spring lockwasher [2x]
- 2 Original vehicle bolt [2x]

Mounting bracket

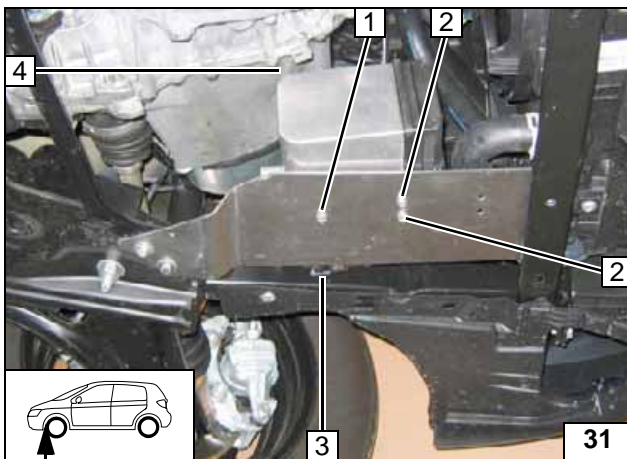

Installing heater

Petrol

Tighten E-JOT screws to 10 Nm. Insert two washers between heater and bracket at position 2. Align heater. Ensure sufficient distance from neighbouring components, especially between heat exchanger and transmission at position 4 as well as between circulating pump and carrier in position 3. Correct if necessary.

- 1 E-jot screw [2x]
- 2 E-jot screw, washer [2x]

Mounting heater

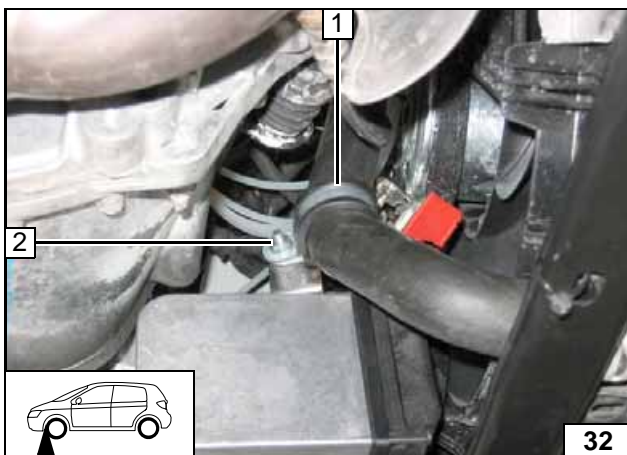

5FW/X/Y - Variant A

Align heater. Ensure sufficient distance from neighbouring components, especially from cooler hose. Correct if necessary. Tighten E-jot screws.

- 1 52 mm dia. rubber-coated p-clamp
- 2 Flanged nut on prepared bolt

Mounting heater

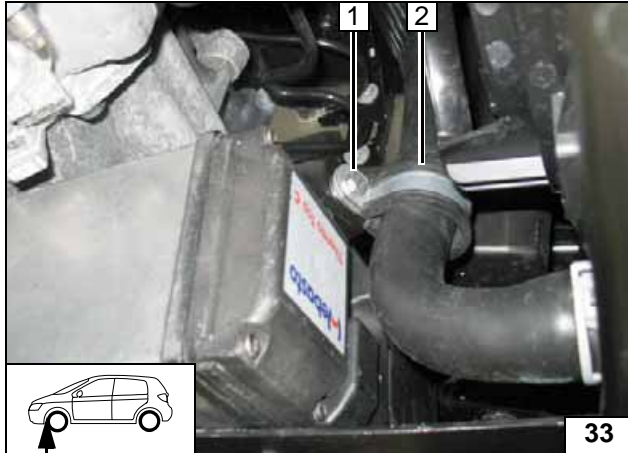
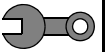

5FW/X/Y - Variant B

Align heater. Ensure sufficient distance from neighbouring components, especially from cooler hose. Correct if necessary. Tighten Ejoyt screws.

- 1 M6x20 bolt, flanged nut on prepared strut
- 2 52 mm dia. rubber-coated p-clamp



Mounting heater

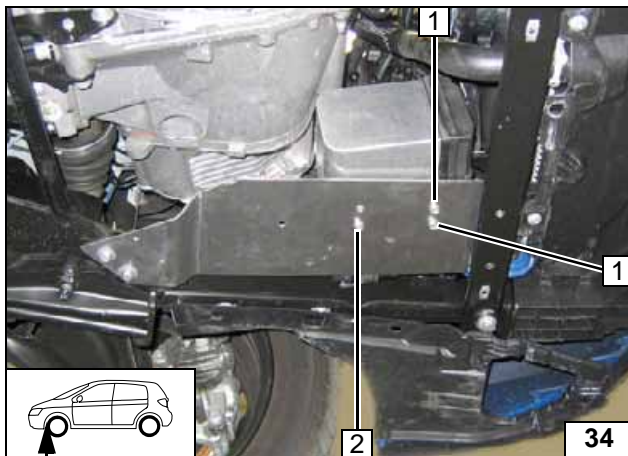

Diesel

Tighten EJOYT screws to 10 Nm. Insert two washers between heater and bracket at position 2.

- 1 Ejoyt screw [2x]
- 2 Ejoyt screw



Mounting heater

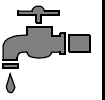

Petrol coolant circuit

WARNING!

Any coolant running off should be collected in an appropriate container. Install hoses so that they are kink-free. Unless specified otherwise, always fasten using cable ties. Position clamps so that other hoses cannot be damaged. The heater must be filled with coolant when installing the hoses. The connection should be "inline" based on the following diagram:

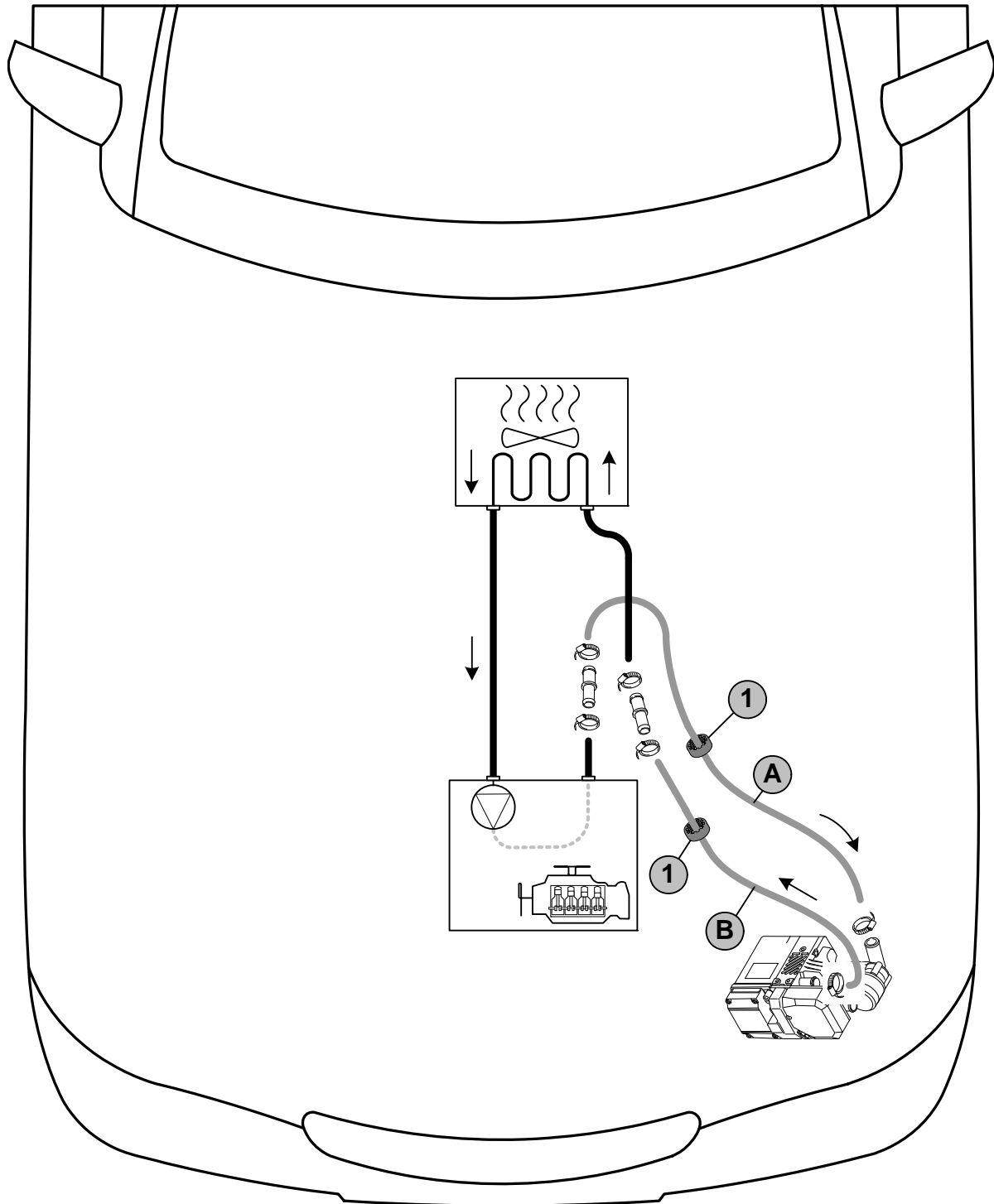

Hose routing diagram

All hose clamps = 20-27 mm dia. 1 = Black (sw) rubber isolator [2x].
 Connecting pipe KFU/NFU = dia. 15x20. Connecting pipe 5FW/X/Y = dia. 17x20.



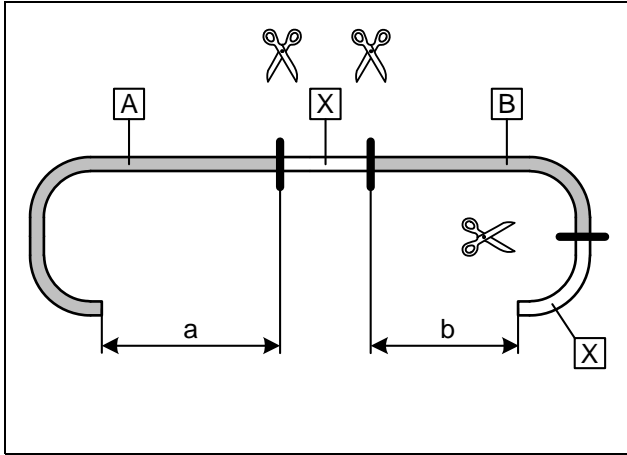

KFU/NFU

a = 640 mm
b = 530mm

Discard section X

Cutting hoses to length

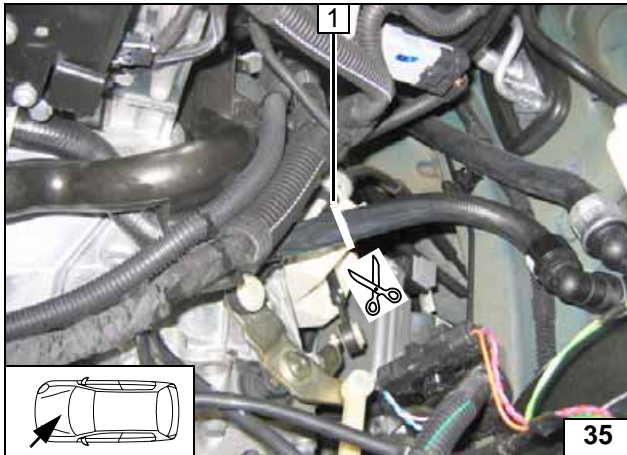

1 Cutting point

Cutting point

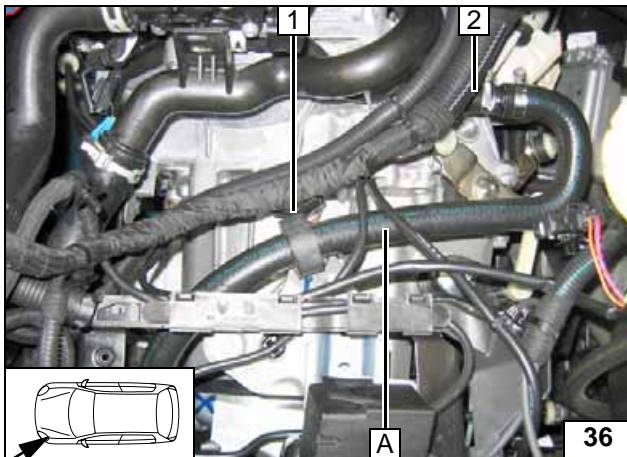

1 Black (sw) rubber profile fastened on transmission mount with cable tie
2 Engine outlet hose section

Connecting engine outlet

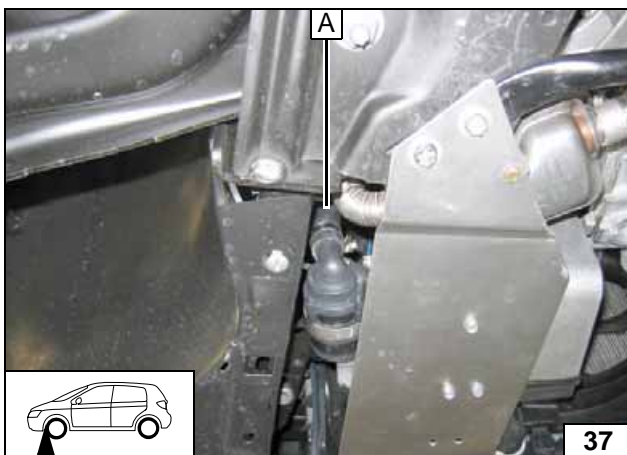

Install coolant hose A with straight end on heater inlet.



Connecting heater

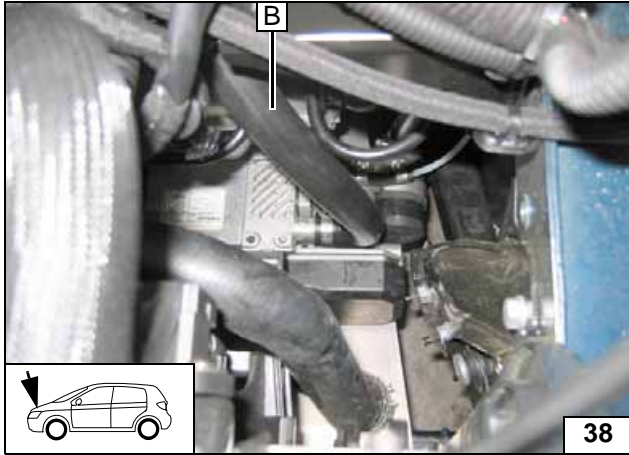
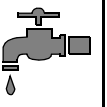

Install coolant hose **B** with 90° elbow on heater outlet.



Connect-
ing heater

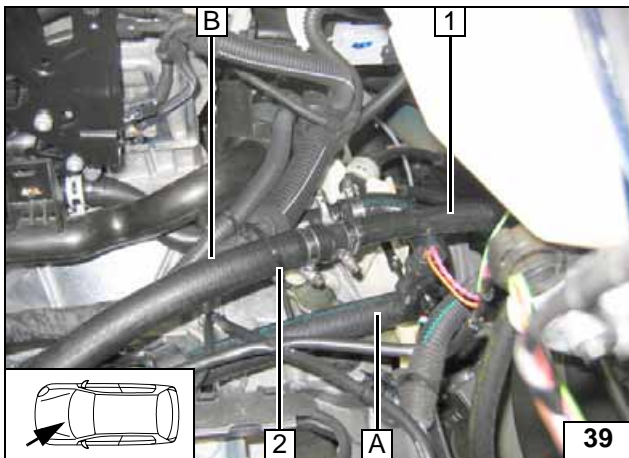

Before connecting, fill the coolant hoses with coolant.

- 1 Hose section of heat exchanger inlet
- 2 Cable tie



Connect-
ing heat
exchanger
inlet

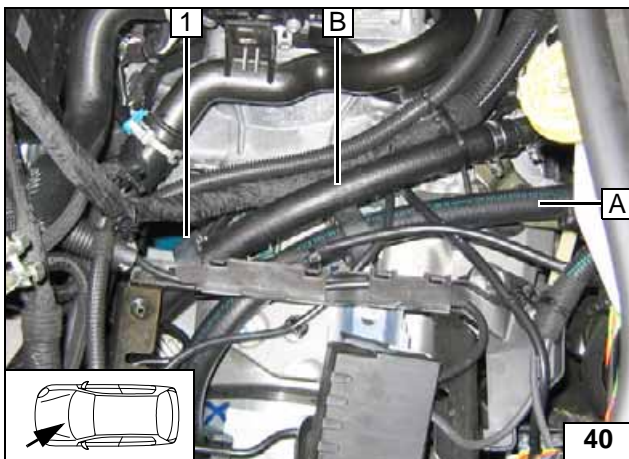

- 1 Black (sw) rubber profile

Routing in
engine
compartment

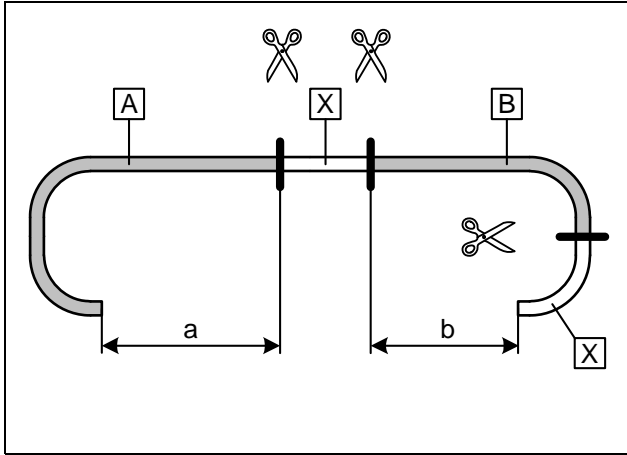

5FW/X/Y

a = 640 mm
b = 530mm

Discard section X

Cutting hoses to length

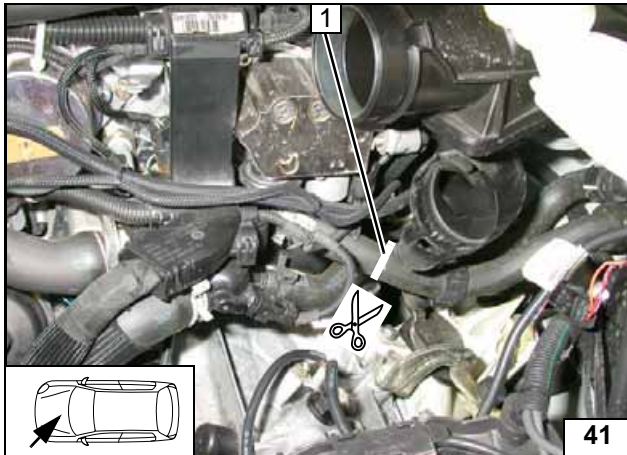

1 Cutting point

Cutting point

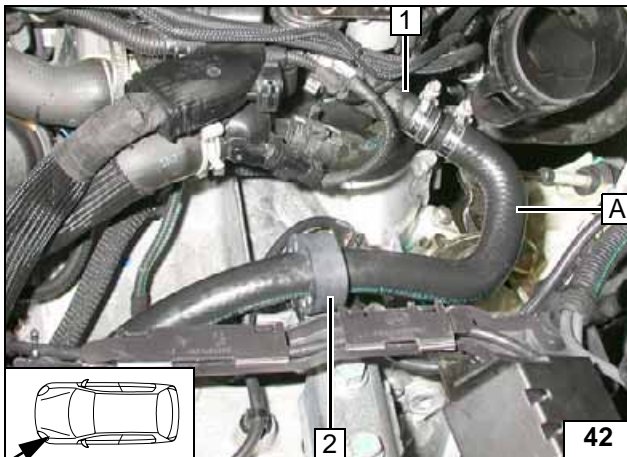

1 Engine outlet hose section
2 Black (sw) rubber profile fastened on transmission mount with cable tie

Connecting engine outlet

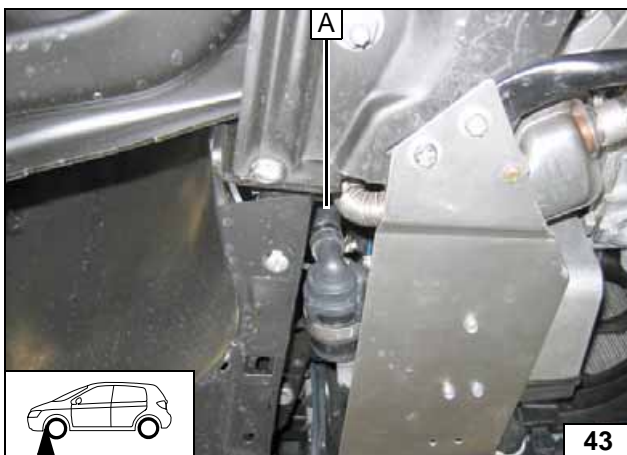

Install coolant hose A with straight end on heater inlet.



Connecting heater

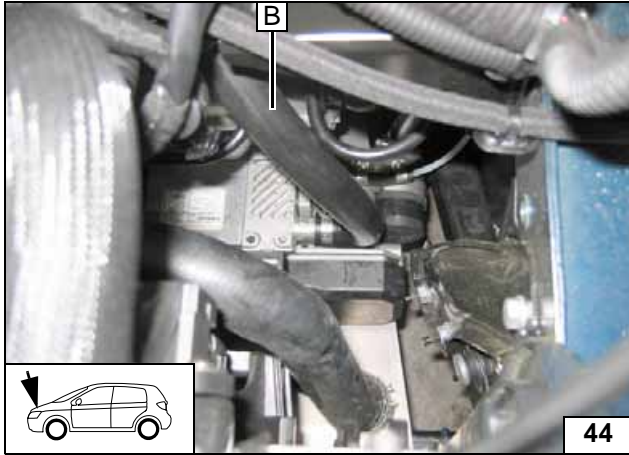

Install coolant hose **B** with 90° elbow on heater outlet.



Connect-
ing heater

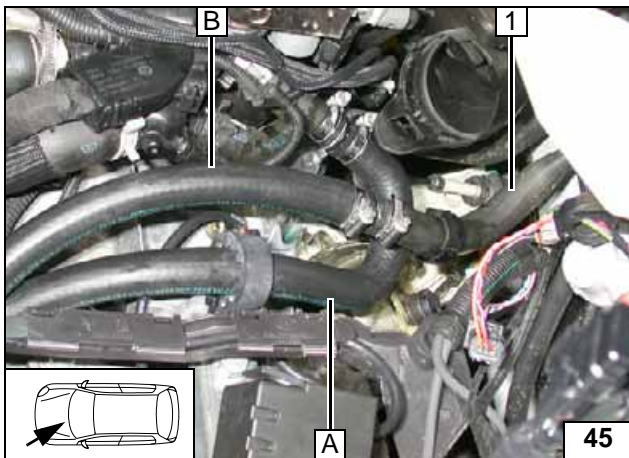

Before connecting, fill the coolant hoses with coolant.

1 Hose section of heat exchanger inlet



Connect-
ing heat
exchanger
inlet

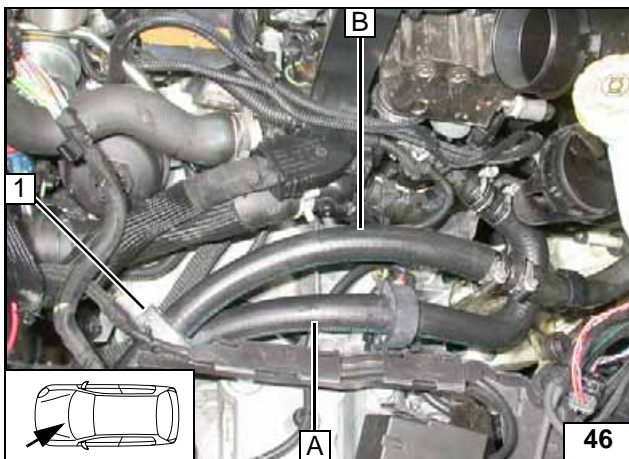

1 Black (sw) rubber profile

Routing in
engine
compartment



Diesel coolant circuit

WARNING!

Any coolant running off should be collected in an appropriate container. Install hoses so that they are kink-free. Unless specified otherwise, always fasten using cable ties. Position clamps so that other hoses cannot be damaged. The heater must be filled with coolant when installing the hoses. The connection should be "inline" based on the following diagram:

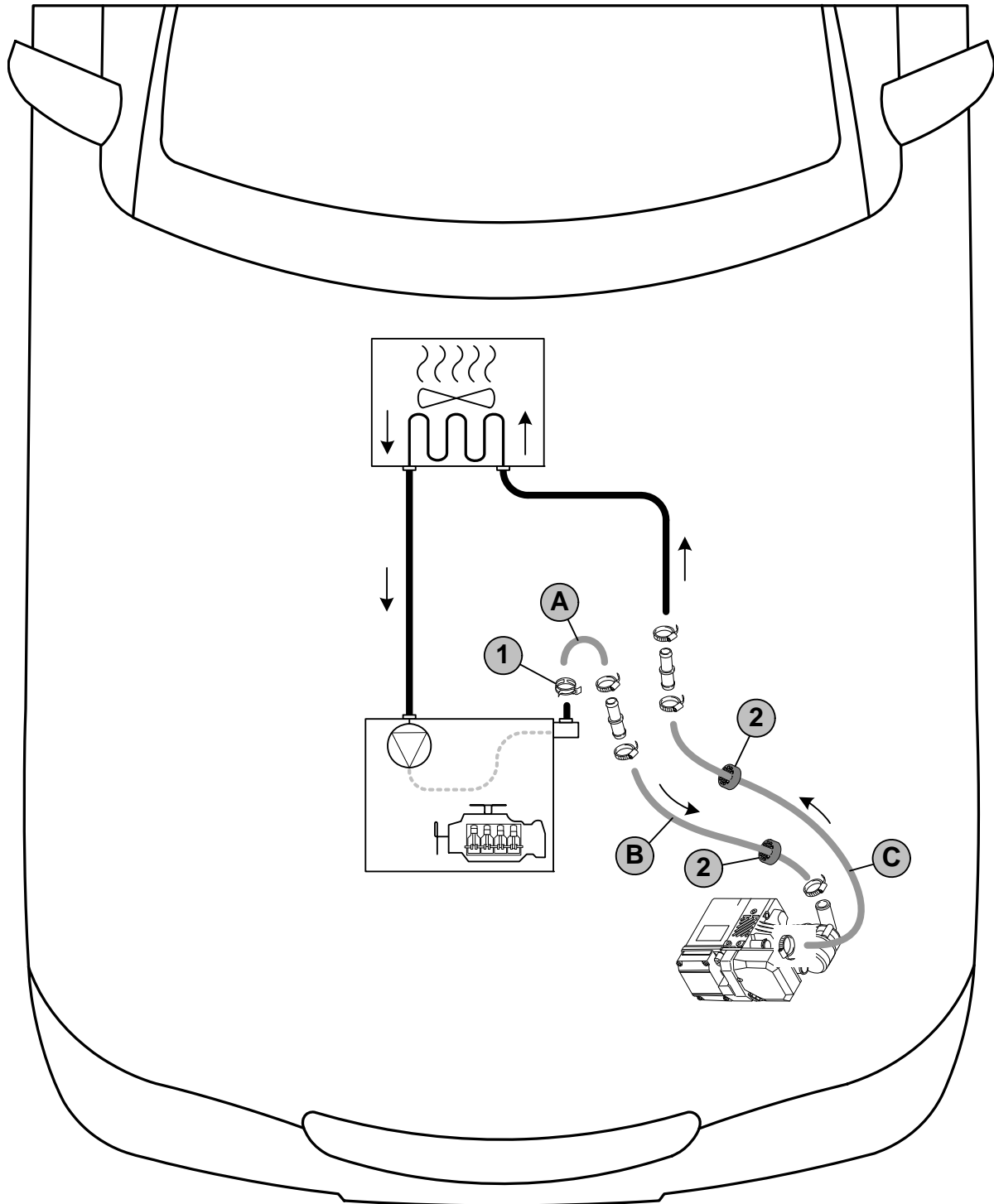

Hose routing diagram

All hose clamps = 20-27 mm dia. **1** = Original vehicle clamp
 All connecting pipes = 18x20 dia.. **2** = Black (sw) rubber isolator [2x].



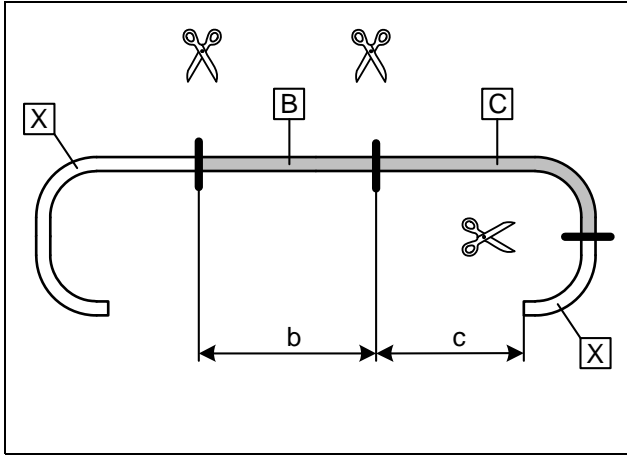

b = 480 mm
c = 390 mm

Discard section X

Cutting hoses to length

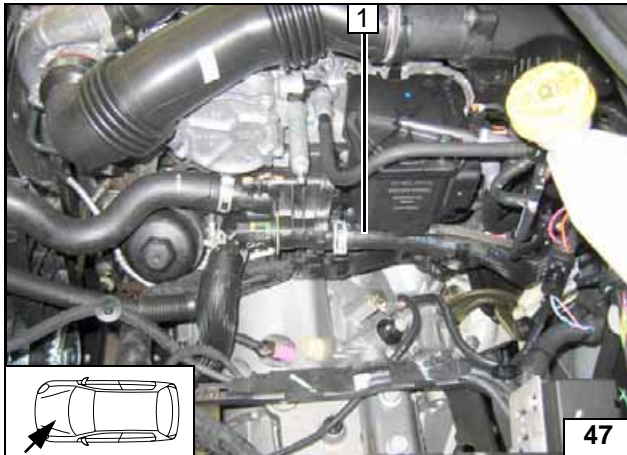

Disconnect coolant hose 1 from engine outlet. Hose clamp will be reused.



Cutting point

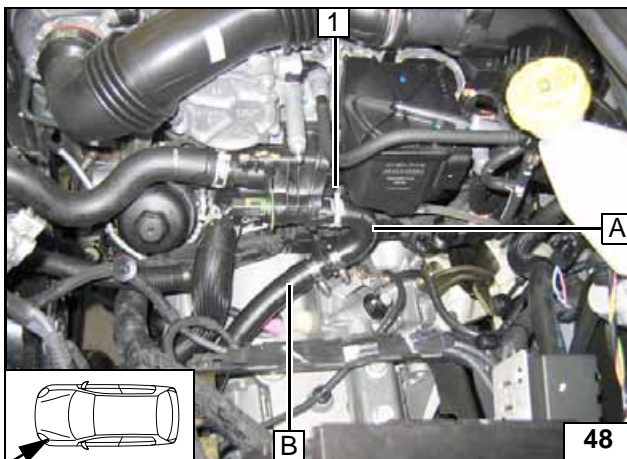

1 Original vehicle hose clamp

Connecting engine outlet

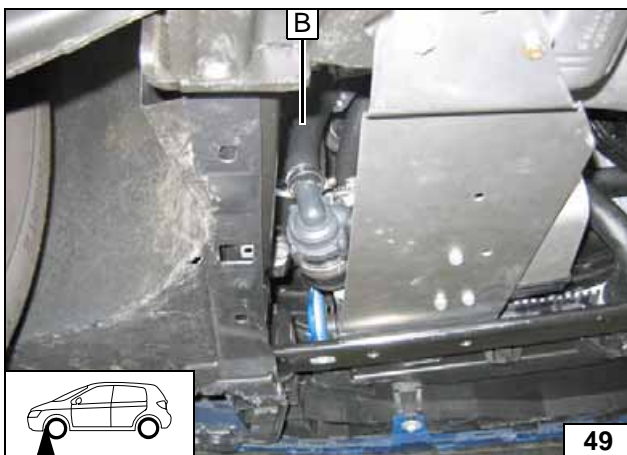

Install coolant hose B with straight end on heater inlet.



Connecting heater

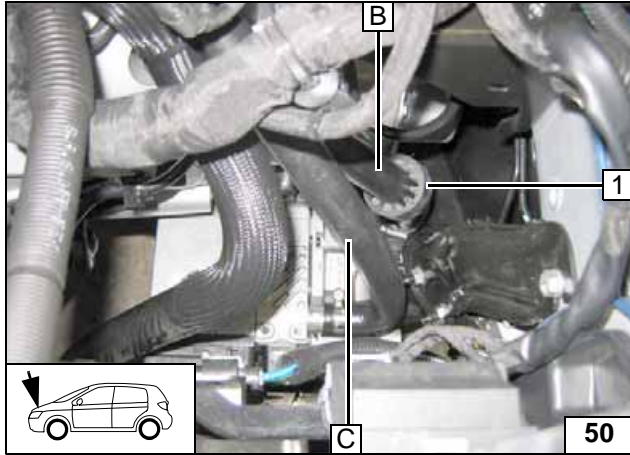

Install coolant hose **C** with 90° elbow on heater outlet.

- 1 Black (sw) rubber profile



Connect-
ing heater

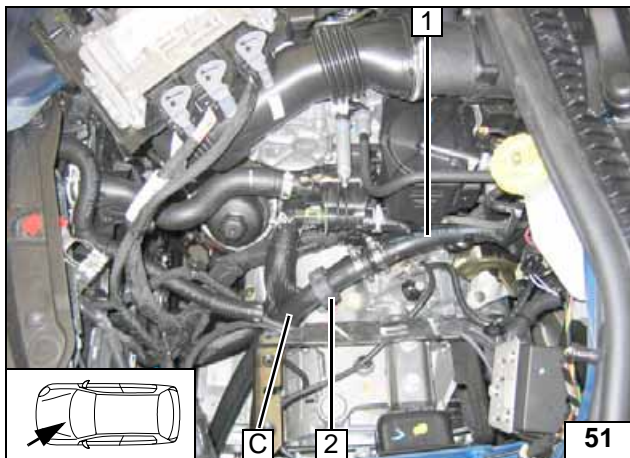

Before connecting, fill the coolant hoses with coolant.

- 1 Hose on heat exchanger inlet
- 2 Black (sw) rubber profile



Connect-
ing heat
exchanger
inlet

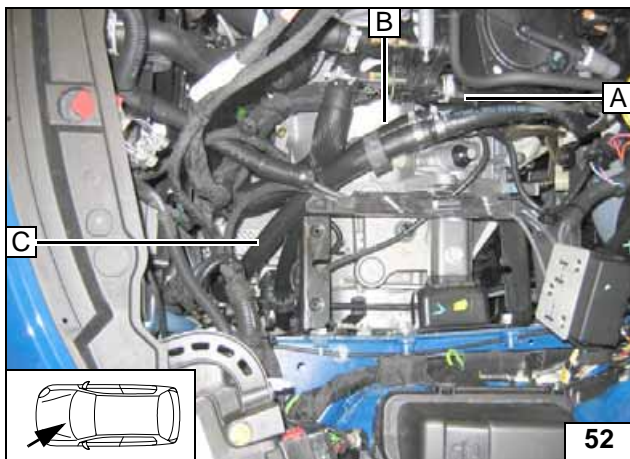

Routing in
engine
compart-
ment

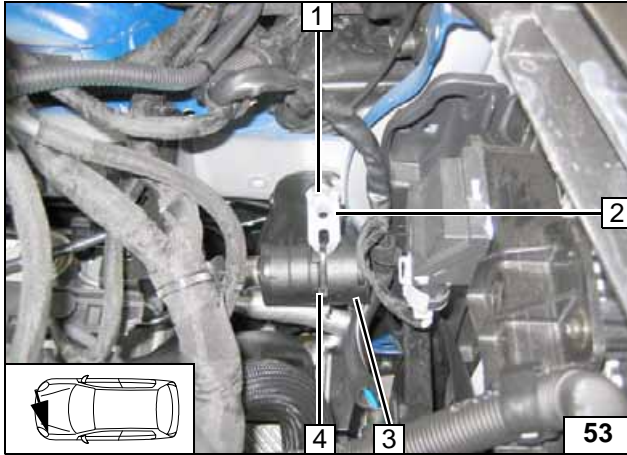
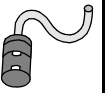

Combustion air

- 1 Original vehicle bolt
- 2 Angle bracket
- 3 Intake silencer
- 4 Cable tie



Installing intake silencer

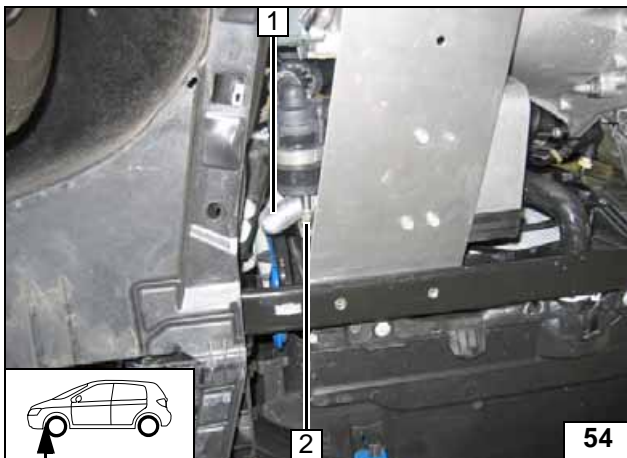

- 1 Intake pipe
- 2 27 mm dia. hose clamp



Mounting intake pipe



Fuel

CAUTION!

Open the vehicle's fuel tank cap, ventilate the tank and then re-close the tank lock.

Catch any fuel running off in an appropriate container.

Install fuel line and metering pump wiring harness so that they are protected against stone impact. Unless specified otherwise, always fasten using cable ties.

Mount the fuel line and wiring harness with rub protection on sharp edges.

WARNING!

The fuel line and wiring harness are routed to the metering pump as shown in the wiring harness routing diagram.

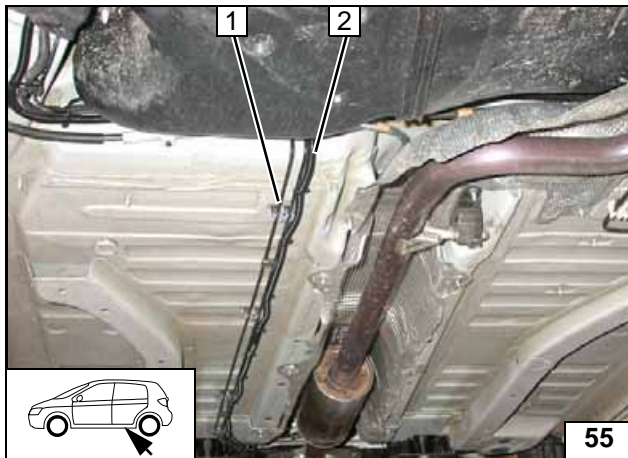

- 1 Original vehicle brake lines
- 2 Fuel line, wiring harness of metering pump in corrugated tube

Routing lines

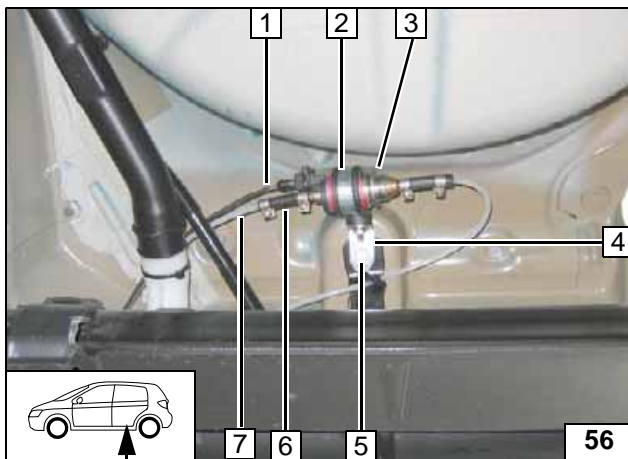

Ensure proper installation position of metering pump, see "Installation Instructions". Installation location behind vehicle fuel tank. Fuel line from heater on pressure side of metering pump [side with connector].

- 1 Metering pump wiring harness
- 2 Rubber-coated p-clamp, silent block, flanged nut [2x]
- 3 Metering pump
- 4 Angle bracket
- 5 Original vehicle bolt
- 6 Hose section, 10 mm dia. hose clamps [2x].
- 7 Fuel line from heater



Installation location of metering pump

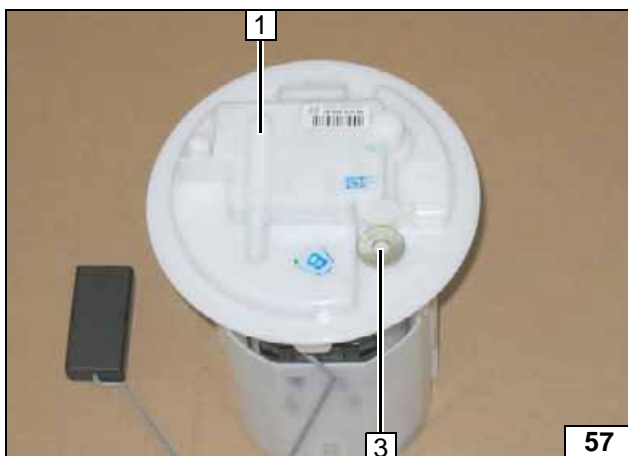

Petrol

Remove fuel-tank sending unit 1 in accordance with manufacturer's instructions.

- 2 Large diameter washer
- 3 Copy hole pattern, 6 mm dia. hole



Removing fuel

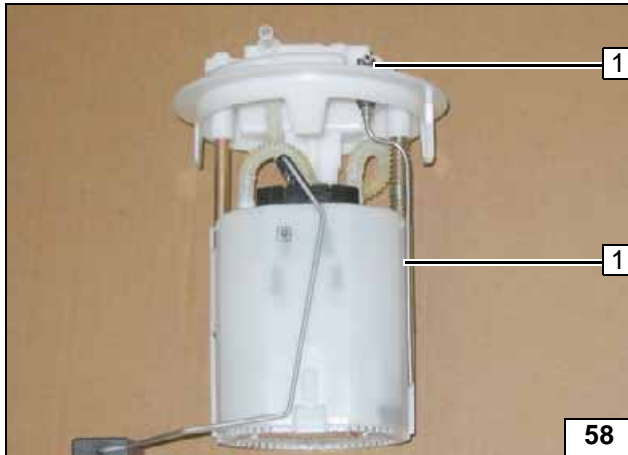

Shape fuel standpipe 1 according to template, cut to length and install, see "installation instructions".



Installing fuel standpipe

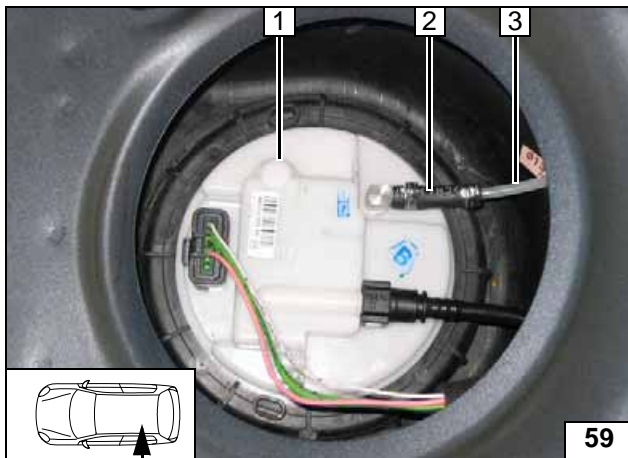

Install fuel-tank sending unit 1 in accordance with manufacturer's instructions.

- 2 Hose section, 10 mm dia. hose clamps [2x].
- 3 Mecanyl fuel line



Connecting fuel line

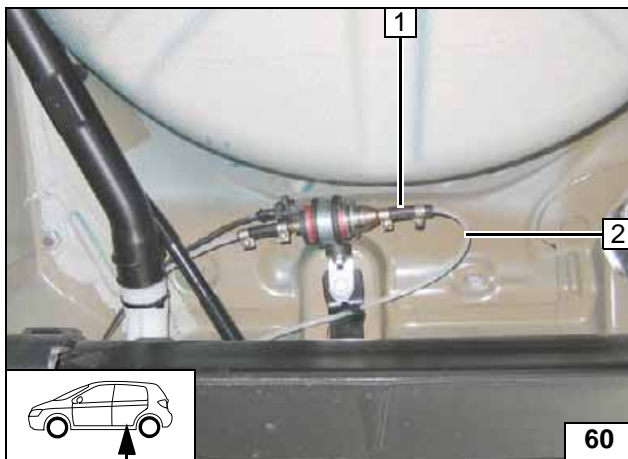

Fuel line from fuel standpipe on intake side of metering pump [side without connector]. Check the position of the components; adjust if necessary. Check that they have freedom of movement.

- 1 Hose section, 10 mm dia. hose clamps [2x].
- 2 Mecanyl fuel line



Connecting to metering pump

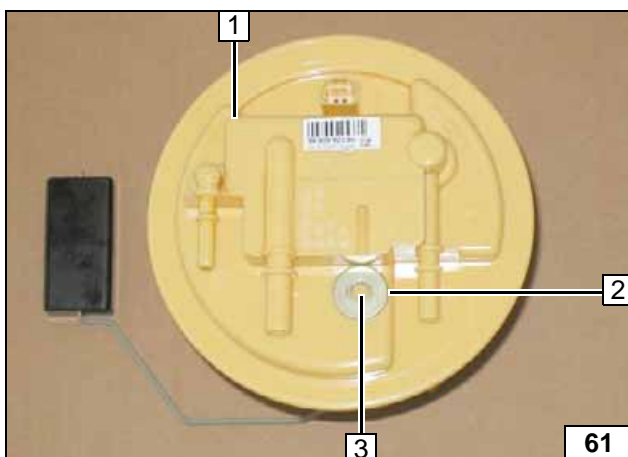

Diesel

Remove fuel-tank sending unit 1 in accordance with manufacturer's instructions.

- 2 Large diameter washer
- 3 Copy hole pattern, 6 mm dia. hole



Removing fuel

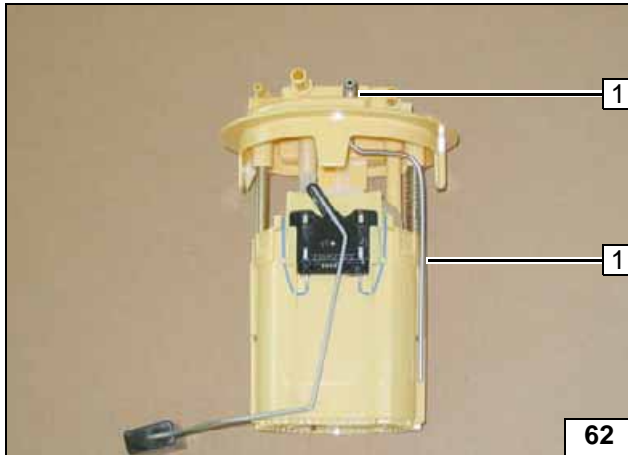

Shape fuel standpipe 1 according to template, cut to length and install, see "installation instructions".



Installing fuel standpipe

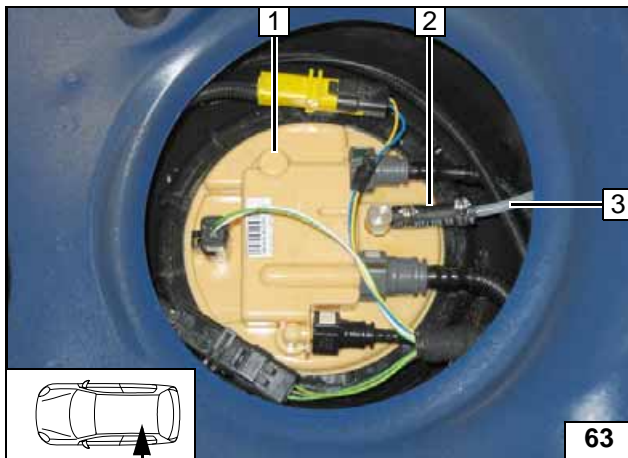

Install fuel-tank sending unit 1 in accordance with manufacturer's instructions.

- 2 Hose section, 10 mm dia. hose clamps [2x].
- 3 Mecanyl fuel line



Connecting fuel line

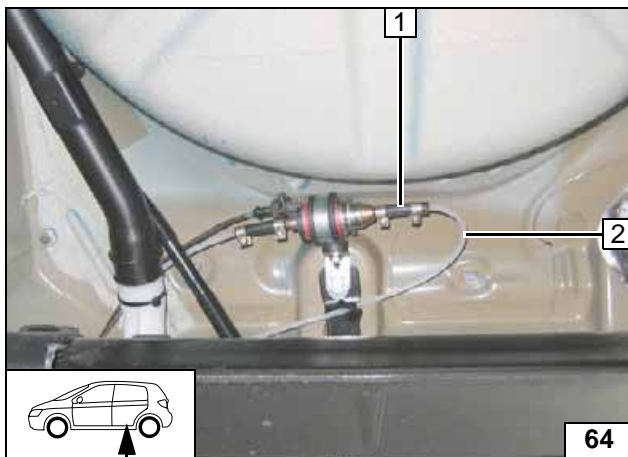

Fuel line from fuel standpipe on intake side of metering pump [side without connector]. Check the position of the components; adjust if necessary. Check that they have freedom of movement.

- 1 Hose section, 10 mm dia. hose clamps [2x].
- 2 Mecanyl fuel line



Connecting to metering pump

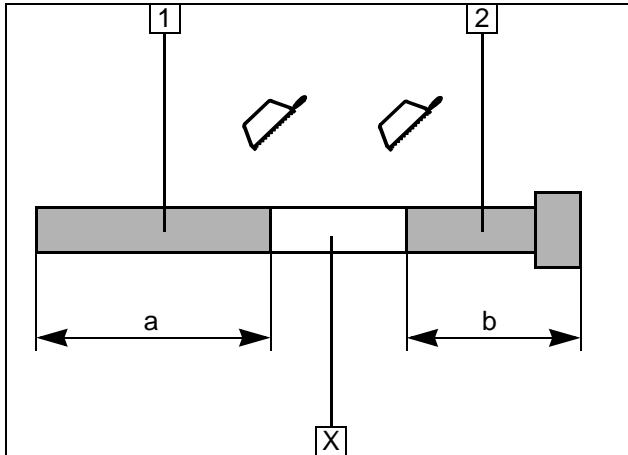

Exhaust gas

Petrol

- 1 Exhaust pipe
a = 230mm
- 2 Exhaust end section
b = 100mm

Discard section X

Preparing exhaust pipe

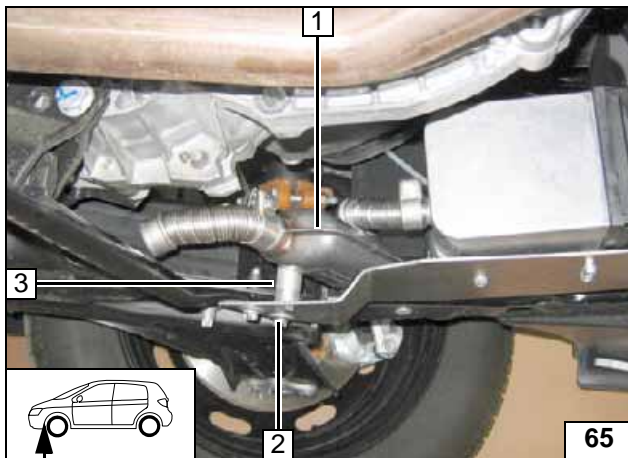

- 1 Silencer
- 2 M6x55 bolt, flanged nut
- 3 40 mm spacer

Mounting silencer

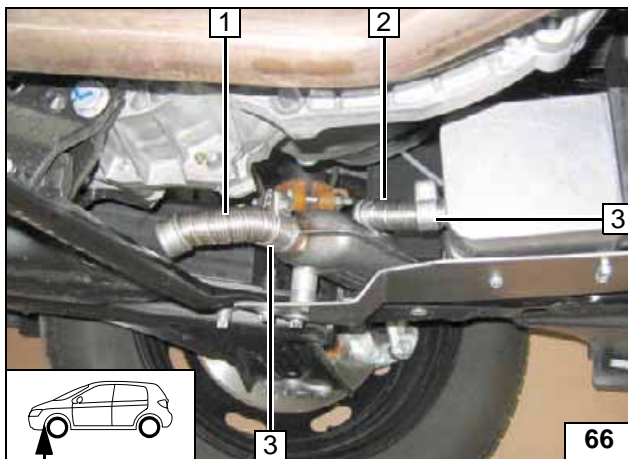

- 1 Exhaust end section
- 2 Exhaust pipe
- 3 Hose clamp [2x]

Mounting exhaust pipe

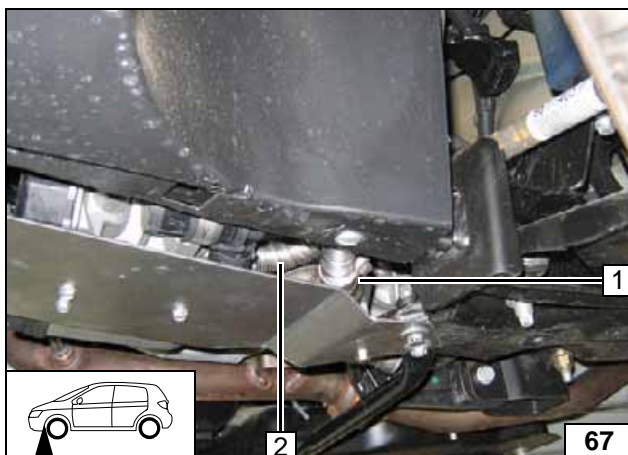

- 1 Hose clamp
- 2 Exhaust pipe

Preparing exhaust pipe

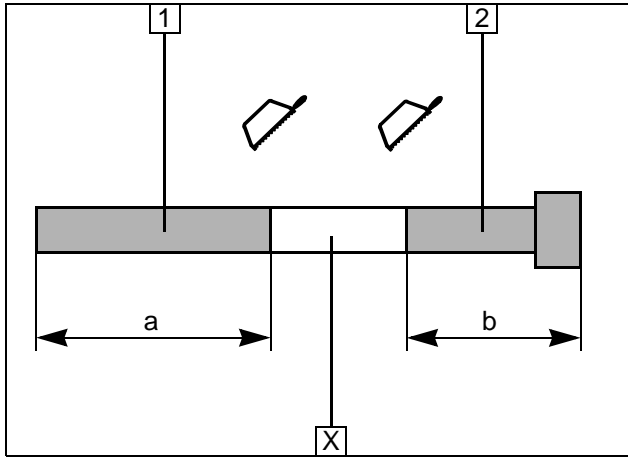

Diesel

- 1 Exhaust pipe
a = 170mm
- 2 Exhaust end section
b = 100mm

Discard section X

Preparing exhaust pipe

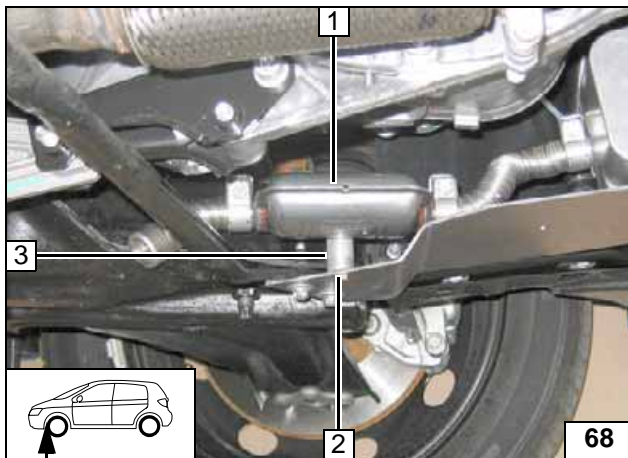

- 1 Silencer
- 2 M6x55 bolt, flanged nut
- 3 40 mm spacer

Mounting exhaust end section

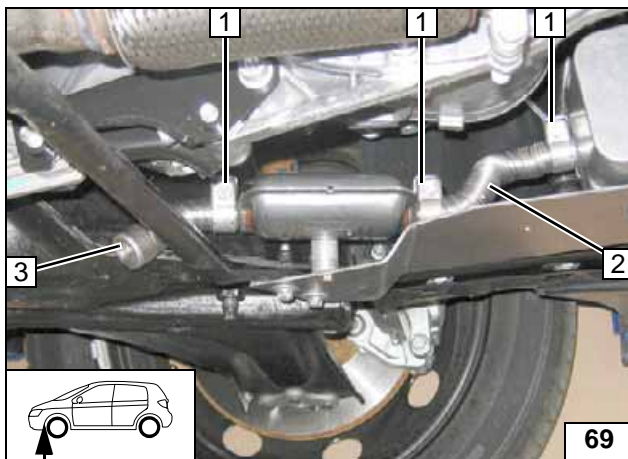

Ensure sufficient distance from neighbouring components.

- 1 Hose clamp [3x]
- 2 Exhaust pipe
- 3 Exhaust end section



Positioning rubber isolator



Final Work

WARNING!

Mount removed parts in reverse order. Check all hoses, clamps and all electrical connections for firm seating. Insulate all loose wires and tie back.

Only use manufacturer-approved coolant. Spray the heater components with anti-corrosion wax (Tectyl 100K, Order No. 111329).

- **Connect the battery**
- **Fill and bleed the coolant circuit according to the vehicle manufacturer's specifications.**
- **Adjust digital timer, teach Telestart transmitter**
- **Make settings on A/C control panel according to the "Operating Instructions for End Customer".**
- **Place the "Switch off parking heater before refuelling" signboard near the filler neck.**
- **For initial start-up and function check, see installation instructions**



Webasto AG
Postfach 80
D-82132 Stockdorf / Germany
National Hotline: 01805 93 22 78
(14 Cent aus dem deutschen Festnetz)
Hotfax: 0395 5592 353
Hotmail: technikcenter@webasto.com
<http://www.webasto.com>

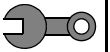

Template for petrol fuel standpipe

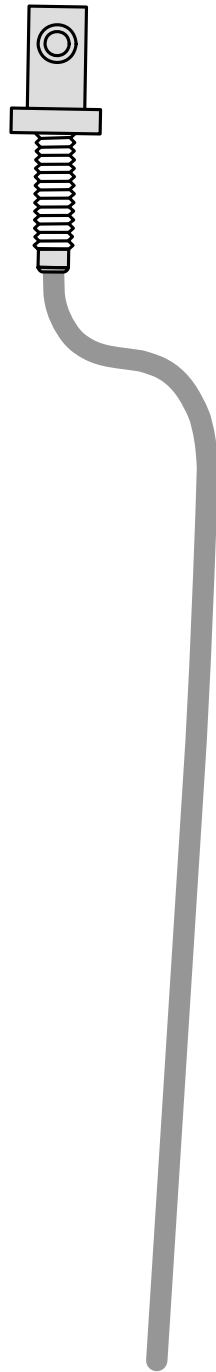

Template for diesel fuel standpipe

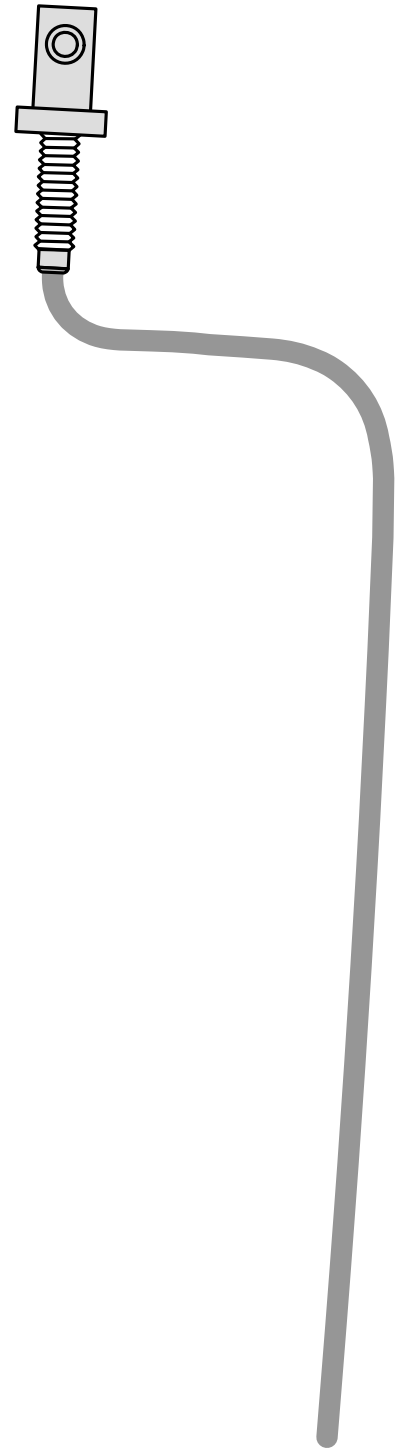

100mm



Scale 1:1

Compare size of the printed version with dimension lines.
Allowed tolerance 2%.

Set the printer settings to "no margin" or "minimise margins"
and 100% of the normal size.

100mm

0

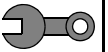

Operating Instructions for End Customer

Please remove page and add to the vehicle operating instructions.





Note:

We recommend matching the heating time to the driving time.

Heating time = driving time

Example:

For a driving time of approx. 20 min. (in one direction), we recommend not exceeding a switch-on time of 20 min.

If the summer/winter switch option has been installed, this must be switched in accordance with the time of year. The heater will then heat in the position Winter  and in the position Summer  it will only switch on the vehicle fan to ventilate the vehicle interior.



Before parking the vehicle, make the following settings:

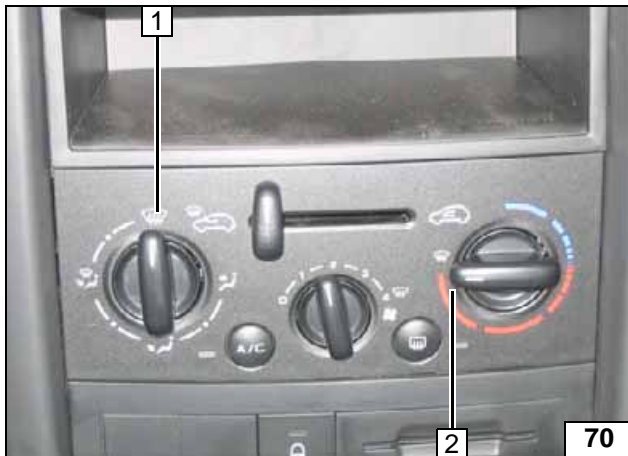

- 1 Air outlet to windscreen
- 2 Set temperature to "max."

Manual air conditioning



- 1 Set temperature on both sides to "max."
- 2 Air outlet to windscreen

Automatic air-conditioning

