

Water Heater



Thermo Top E Parking Heater

00 0003

Thermo Top C Parking Heater

00 0002

Thermo Top P Parking Heater

00 0104

Installation documentation

Toyota Auris

Diesel

from Model Year 2007

For left-hand drive vehicles only



WARNING!

Hazard warning:

Incorrect installation or repair of Webasto heating systems may cause a fire or result in the emission of carbon monoxide, which can be fatal. Serious or fatal injuries can be caused as a result.



Specialist company training, technical documentation, specialised tools and equipment are required to install and repair Webasto heating and cooling systems. Only original Webasto parts must be used. For this, also see the catalog of air and water heater accessories from Webasto.

NEVER attempt to install or repair Webasto heating or cooling systems if you have not successfully completed the company training and thereby acquired the required technical skills, or if you do not have access to the required technical documentation, tools and equipment needed to carry out correct installation and repairs.

ALWAYS follow all Webasto installation and repair instructions and observe all warnings.

Webasto does not accept any liability for defects and damage that are attributable to installation by untrained staff.

Table of Contents

Validity	2	Preparing installation location	13
Heater/Installation Kit	3	Preparing and installing bracket	13
Foreword	3	Installing heater	14
General Instructions	3	Coolant circuit 1.4 D	16
Special Tools	3	Coolant circuit 2.0 and 2.2 D	20
Explanatory Notes on Document	4	Fuel	24
Preliminary Work	5	Exhaust gas	26
Heater installation location	5	Combustion air	27
Electrical Connections	6	Final Work	28
Automatic air-conditioning fan controller	8	Operating Instructions for End Customer	29
Fan controller for manual air conditioning	10		
Remote option (Telestart)	11		
Remote option Thermo Call	12		

Validity

Manufacturer	Model	Type	EG-BE No./ABE
Toyota	Auris	E15	e11 * 2001 / 116 * 0299 * ...
Toyota	Auris	E15	e11 * 2001/116 * 0305 * ...

Engine type	Engine model	Output in kW	Displacement in cm ³
1ND-TV	Diesel	66	1364
1AD-FTV	Diesel	93	1998
2AD-FHV	Diesel	130	2231

Vehicle and engine types, equipment variants and national specifications not listed in this installation documentation have not been tested. However, installation according to this installation documentation may be possible.

The installation location of a digital timer and summer/winter switch should be confirmed with the end customer before installation.

Heater/Installation Kit

Quantity	Description	Order No.:
1	Retail accessories with desired heater control	See price list
1	Installation kit for Toyota Auris Diesel	1312801C

Heater recommended for the respective vehicle class:

Vehicle	Heater
Compact car	Thermo Top E
Mid-size car, station wagon	Thermo Top C
Full-size car, van, offroader	Thermo Top P

The selection of the heater is based on the passenger compartment size of the vehicle and the level of comfort required by the customer!



Foreword

This installation document applies to vehicles Toyota Auris Diesel - for validity, see page 2 - from model year 2007 and later, assuming technical modifications to the vehicle do not affect installation, any liability claims excluded. Depending on the vehicle version and equipment, modifications may be necessary during installation with respect to this installation documentation.

However, the stipulations in the "installation documentation" and "operating and maintenance instructions" for the *Thermo Top C/P/E* must always be observed.

The corresponding rules of technology and any information from the vehicle manufacturer should be observed during the installation work.

General Instructions

Installation should be carried out according to the general, standard rules of technology. Unless specified otherwise, fasten hoses, lines and wiring harnesses to original vehicle lines and wiring harnesses using cable ties.

Sharp edges should be fitted with edge protectors (split-open plastic hose).

Spray unfinished body areas, e.g. drilled holes, with anti-corrosion wax (Tectyl 100K, Order No. 111329).

Special Tools

- Torque wrench for 2.0 - 10 Nm
- Hose clamping pliers
- Metric thread-setter kit

Explanatory Notes on Document

To provide you with a quick overview of the individual working steps, you will find an identification mark on the outside top right corner of the page in question.

Mechanical system

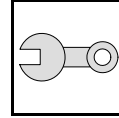

Electrical system

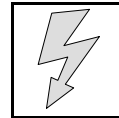

Coolant circuit

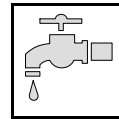

Fuel

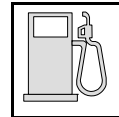

Exhaust gas

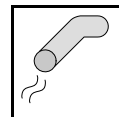

Combustion air

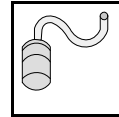

Special features are highlighted using the following symbols:



Specific risk of injury or fatal accidents.



Specific risk of damage to components.



Specific risk of fire or explosion.



Reference to general installation instructions of Webasto components or to the manufacturer's vehicle-specific documents.



Reference to a special technical feature.

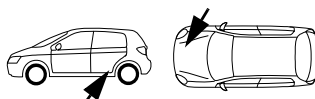

The arrow in the vehicle icon indicates the position on the vehicle and the viewing angle.

All dimensions are in mm!

Tightening torque of hose clamps = 2.0 + 0.5 Nm!

Tightening torque of Ejet screws, Ejet studs = 10 Nm!

Preliminary Work

WARNING!

- Open the fuel tank cap, ventilate the tank.
- Close the tank cap again.
- Disconnect the battery "earth" or "ground" connection.
- Depressurize the cooling system.
- Copy the factory number from the original type label to the duplicate type label.
- Remove years that do not apply from the duplicate label.
- Attach the duplicate label (type label) in the appropriate place.
- Remove the battery completely.
- Remove the air filter together with the intake hose.
- Remove the coolant reservoir cap.
- Remove the bumper.
- Remove the underride protection.
- Remove the side wheel well trim on the left
- Remove the footwell trim on the driver's side

Remove page 29 "Operating Instructions for End Customer" and add to the vehicle operating instructions.

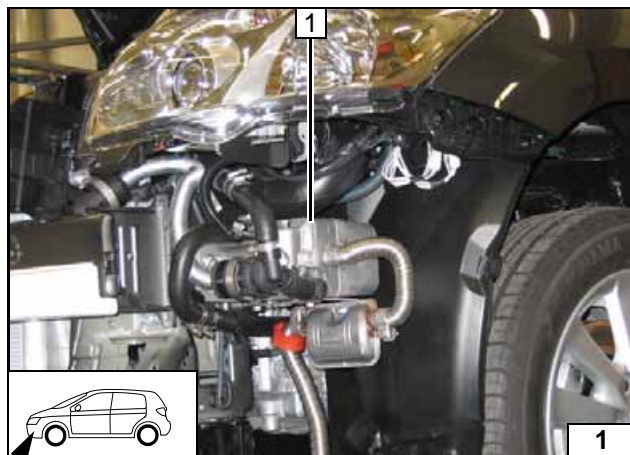

Heater installation location

Figure shows vehicle up to MJ 2009

1 Heater



Installation location



Electrical Connections

Fuse holder, K3 relay

Replace 25 A fuse F3 with 10 A fuse.

- 1 M6x20 bolt, spring lockwasher, large diameter washer on existing thread
- 4 M5x16 bolt, large diameter washer, fuse holder 3, angle bracket 2, K3 relay 5, M5 flanged nut

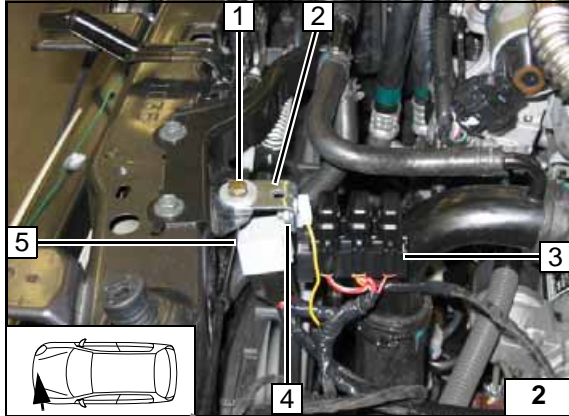

Wiring harness routing

- 1 Shorten corrugated tube to 700 mm
- 2 Pull wiring harness of fan controller and digital timer into corrugated tube and route to firewall together as shown

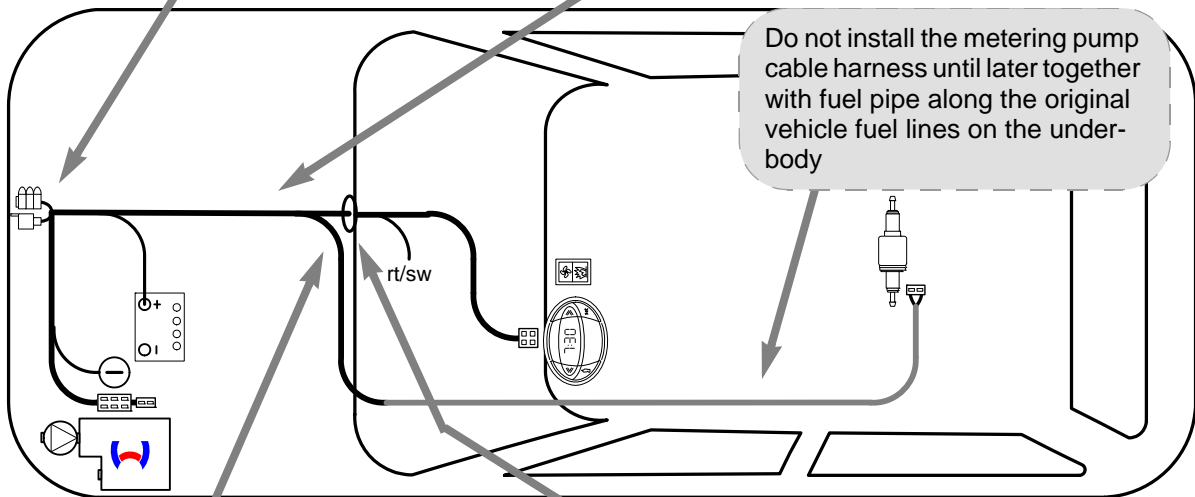
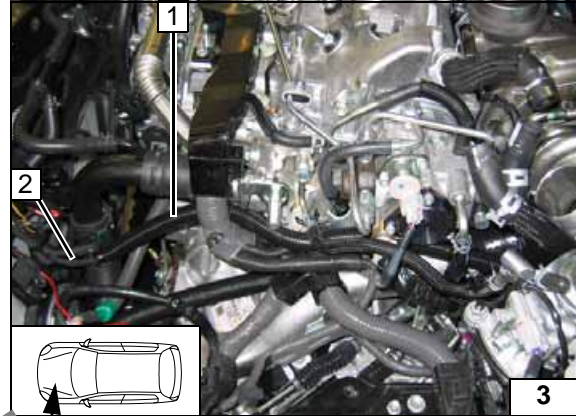

Wiring harness installation diagram

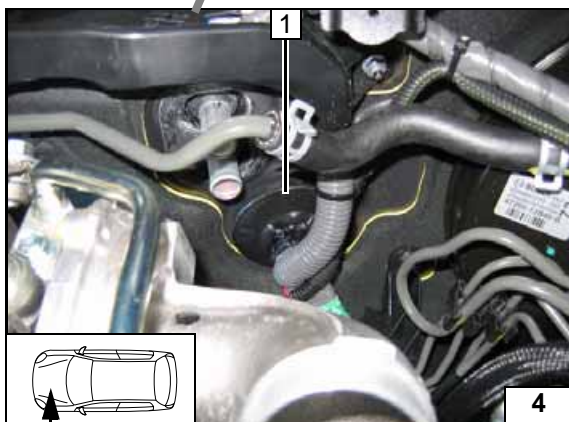

Wiring harness pass through

- 1 Protective rubber plug

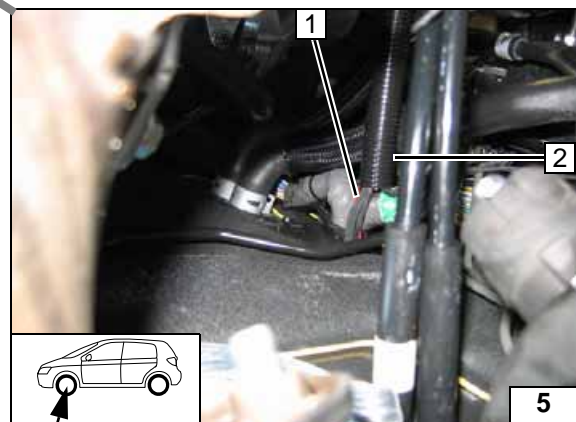

Wiring harness pass through

- 1 Wiring harness of digital timer and fan controller
- 2 Corrugated tube



Positive wire

- 1 Positive battery terminal
- 2 Cut positive wire to length, 8 mm dia. cable lug

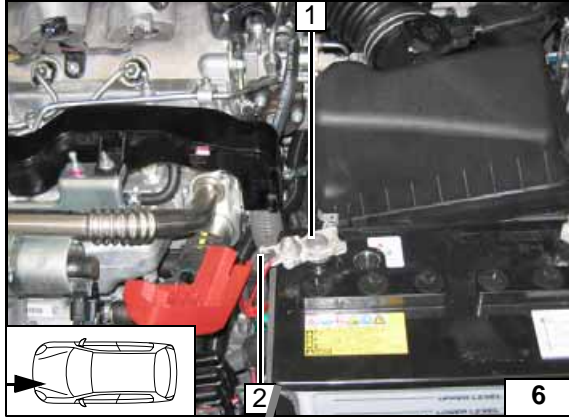

Digital timer and summer/winter switch option

- 1 Digital timer
- 2 Summer/winter switch, drilled hole 12 mm dia.

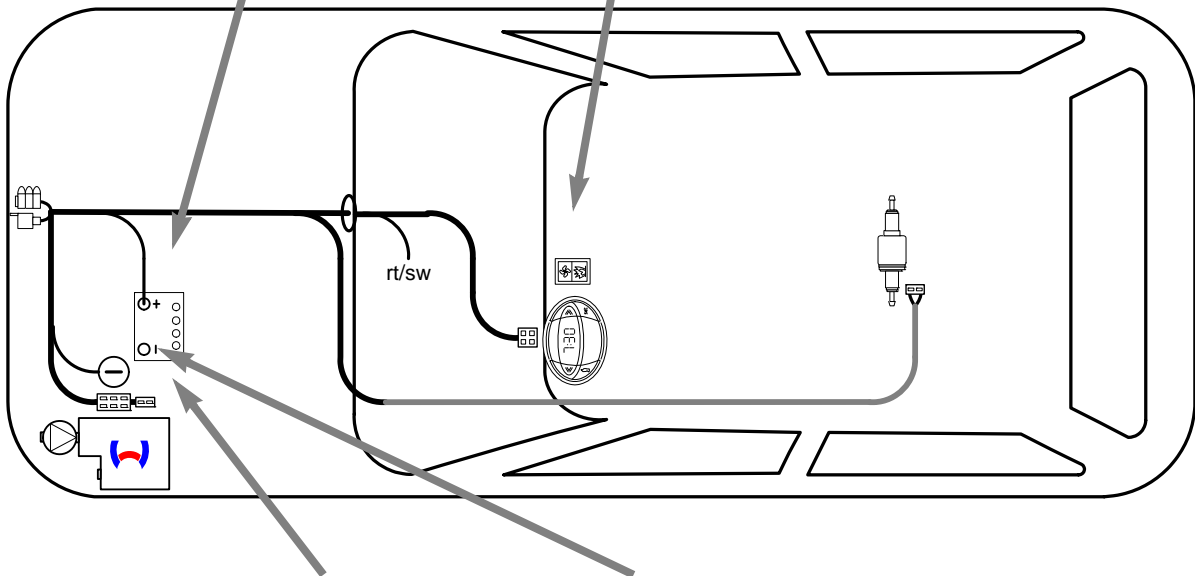
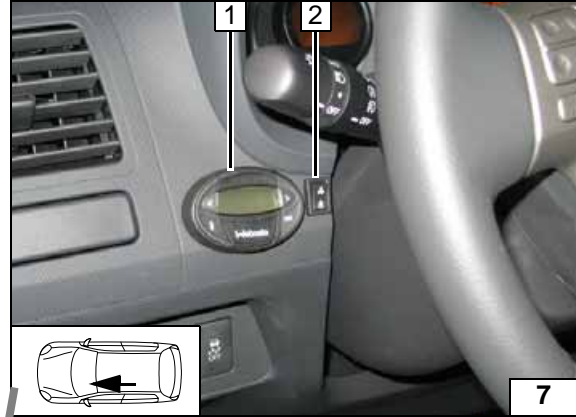

Wiring harness installation diagram

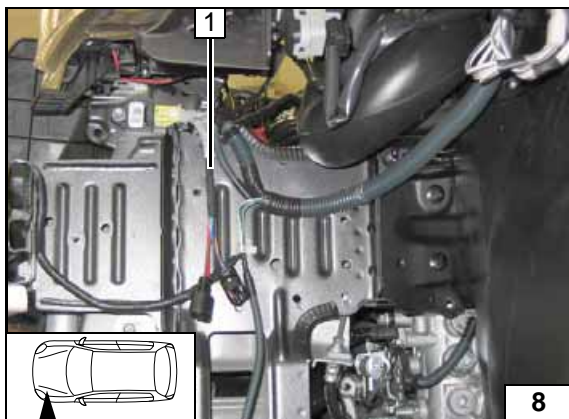

Wiring harness routing

- 1 Route wiring harness of heater to installation location

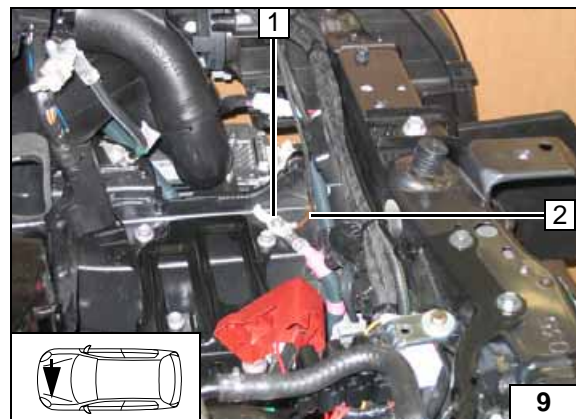

Ground wire

- 1 Original M6 bolt of vehicle
- 2 Ground wire



Automatic air-conditioning fan controller



Wiring diagram

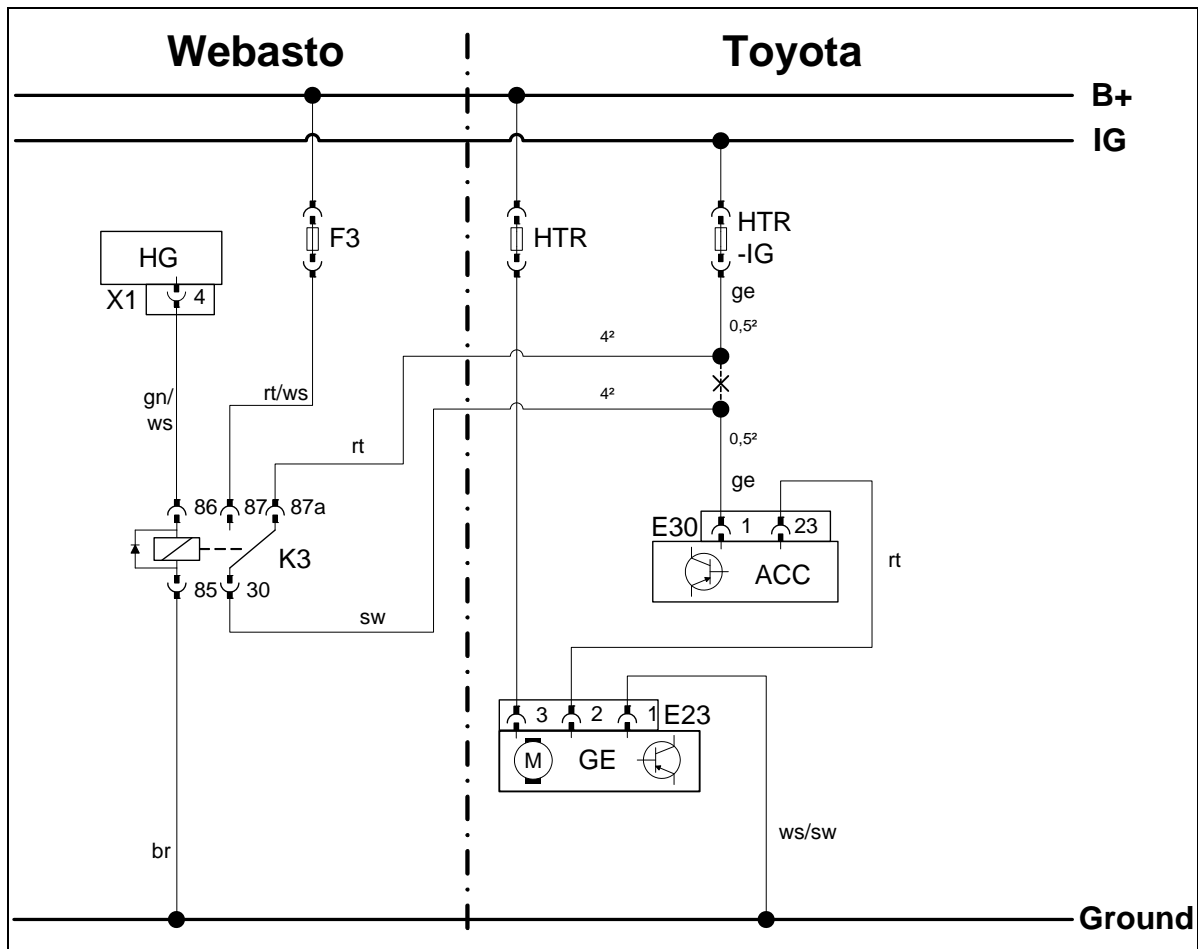

Webasto components		Vehicle components		Colours and symbols	
HG	Heater TT-C/E/P	GE	Fan unit	rt	red
X1	6-pin heater connector	E23	GE connector	ws	white
F3	Replace 25 A with 10 A fuse	ACC	AC control	sw	black
K3	Fan relay	E30	40-pin ACC connector	br	brown
		HTR	30A fuse	gn	green
		HTR-IG	10 A fuse	ge	yellow
				X	Cutting point
				Wiring colours may vary.	

Legend

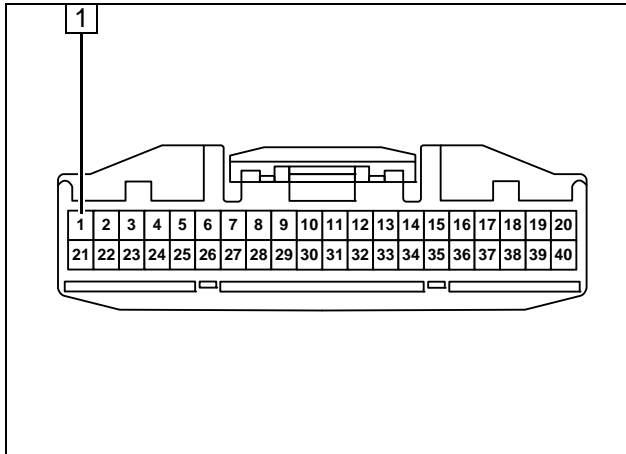

1 Connector E30 on contact side (PIN 1)

E30 connector

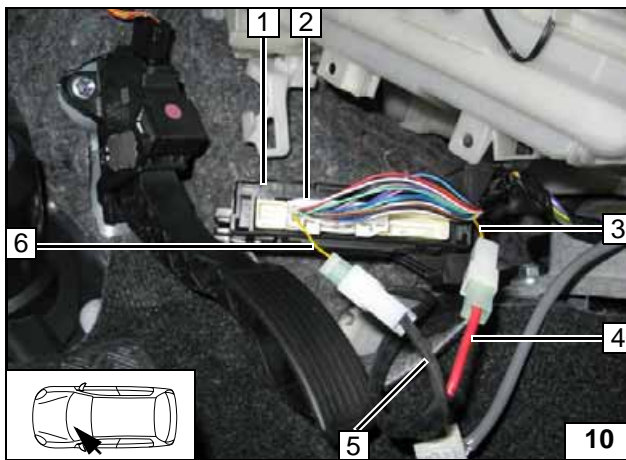

Connection on Pin 1 from E30 40-pin connector 2 from ACC 1.
Produce connections as shown in wiring diagram.



- 3 Yellow (ge) wire of Fuse HTR IG
- 4 Red (rt) wire of K3/87a
- 5 Black (sw) wire of K3/30
- 6 Yellow (ge) wire to connector E30 Pin 1

Connection to ACC



Fan controller for manual air conditioning

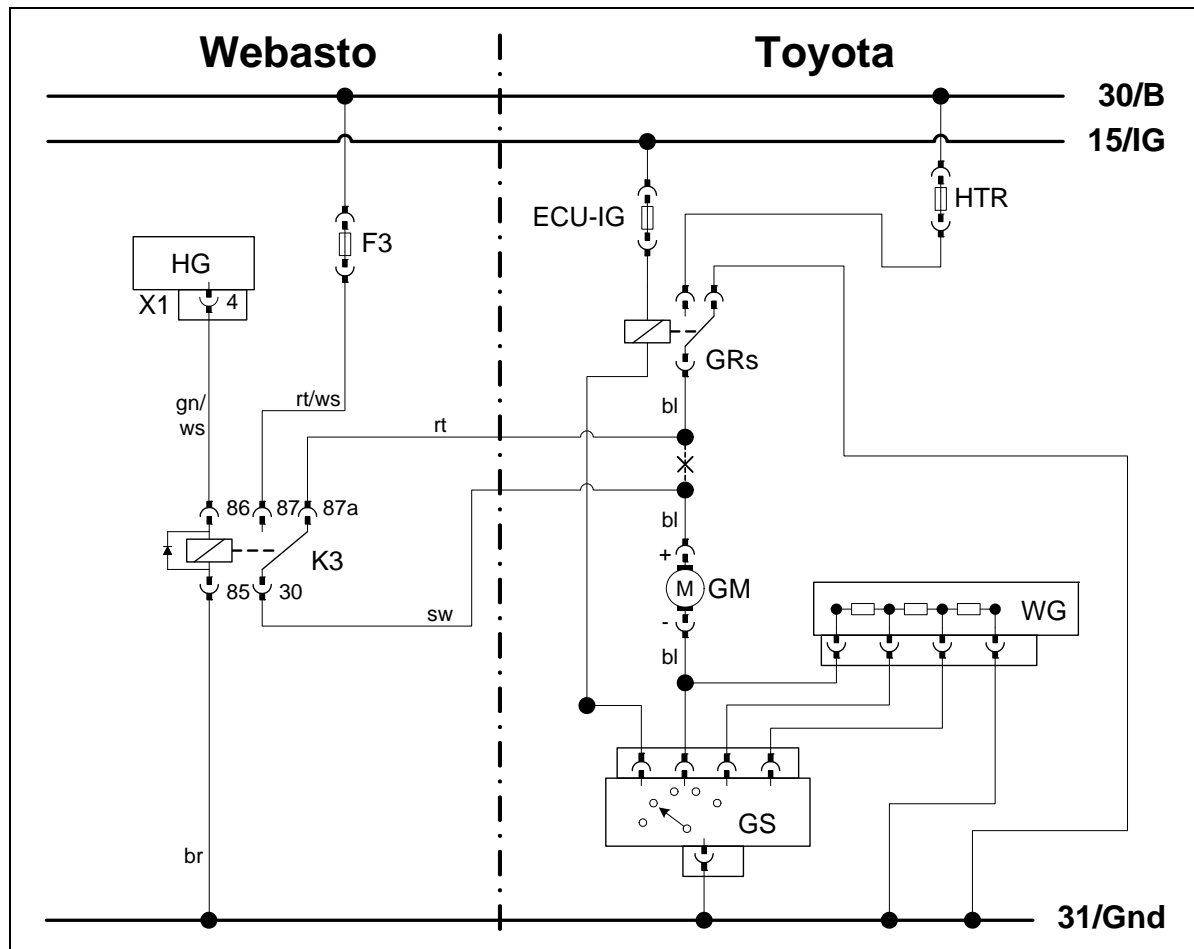

Wiring diagram

Webasto components		Vehicle components		Colours and symbols	
HG	Heater TT-C/E/P	GM	Fan motor	rt	red
X1	6-pin heater connector	GRs	Fan relay	ws	white
F3	25A fuse	GS	Fan switch	sw	black
K3	Fan relay	WG	Resistor group	br	brown
		HTR	50A fuse	gn	green
		ECU-IG	10 A fuse	bl	blue
					Insulate wire ends and tie back
				X	Cutting point
Wiring colours may vary.					

Legend

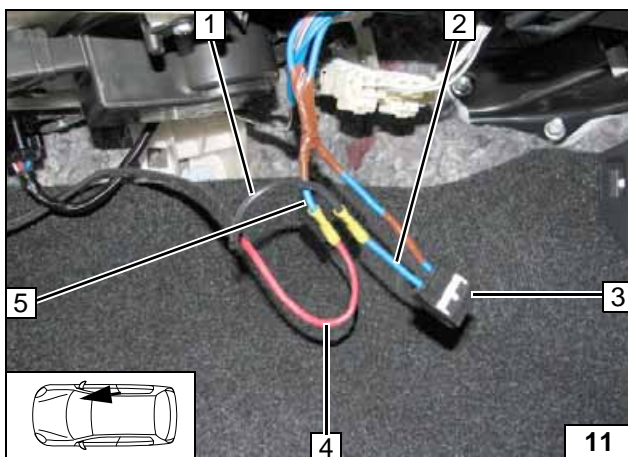

Connection to 2-pin connector 3 from the blower motor.
Produce connections as shown in wiring diagram.

- 1 Black (sw) wire of K3/30
- 2 Blue (bl) wire fan motor connector
- 4 Red (rt) wire of K3/87a
- 5 Blue (bl) wire of HTR

Connecting fan motor

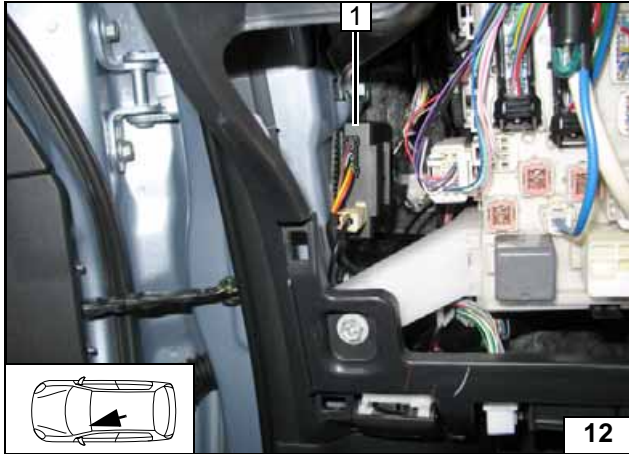

Remote option (Telestart)

Fasten receiver 1 with adhesive tape.



Installing receiver

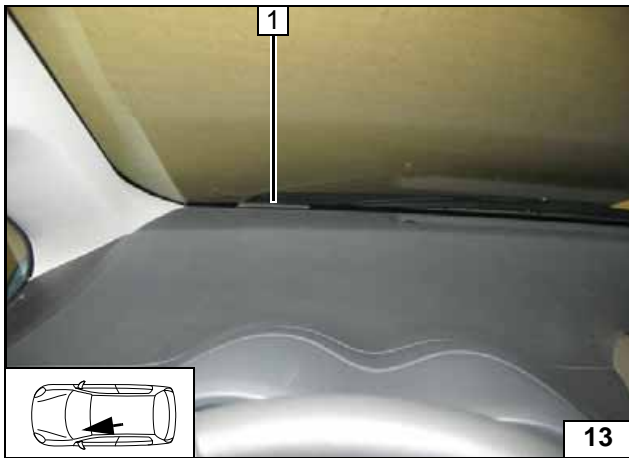

1 Antenna

Installing antenna

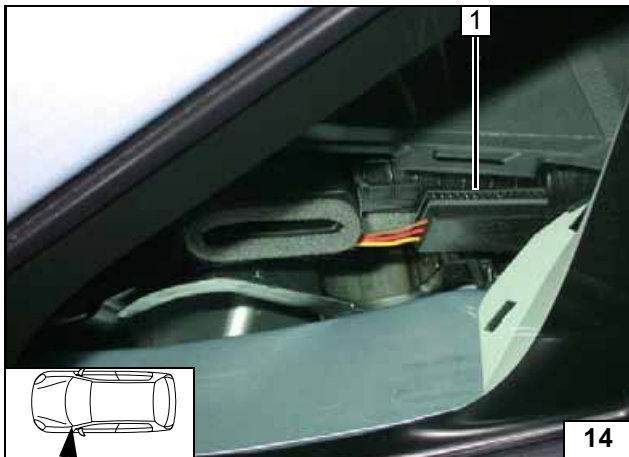

Temperature sensor for HTM100 only

Fasten temperature sensor 1 with adhesive tape.



Installing temperature sensor

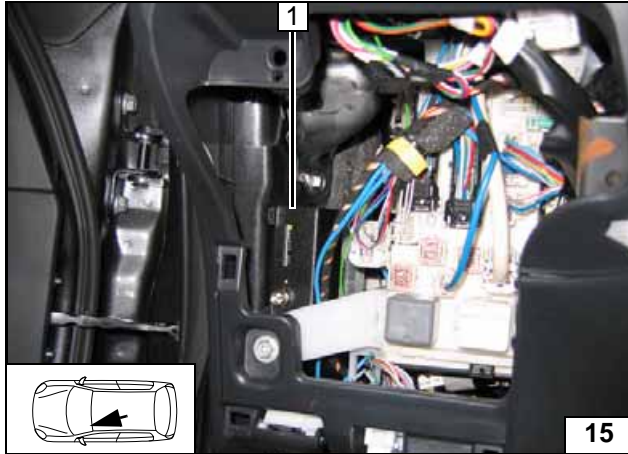

Remote option Thermo Call

Fasten receiver 1 with adhesive tape.



Installing receiver

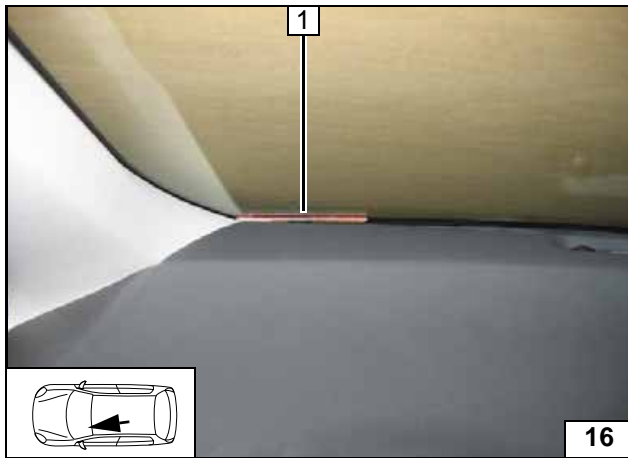

1 Antenna

Installing antenna

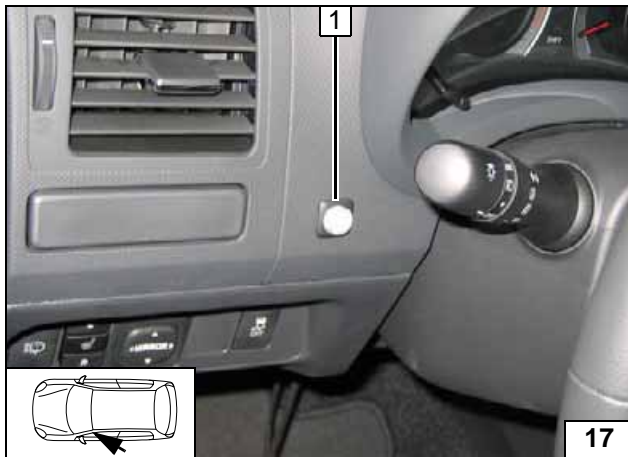

1 Push button

Installing push button

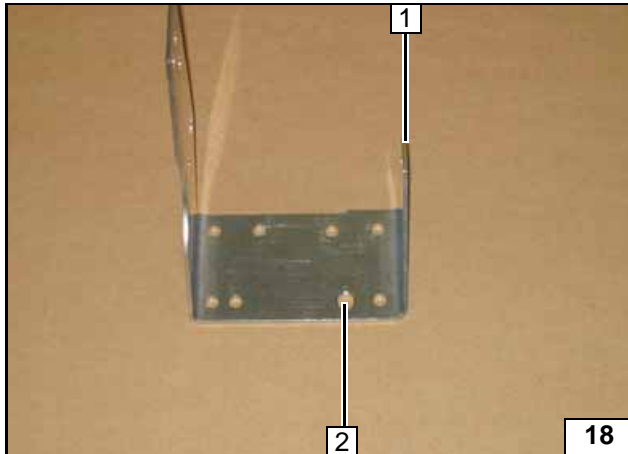
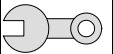

Preparing installation location

- 1 Bracket
- 2 Drill out hole to 8.5 mm dia.

Drilling bracket

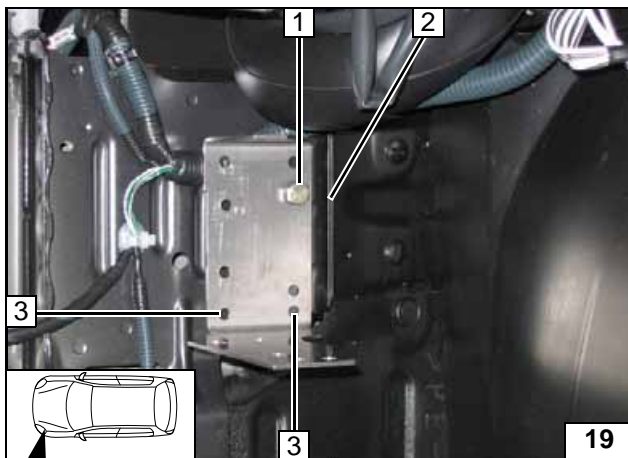

When installing bracket, align it parallel to original vehicle edge 2.

- 1 M8x40 bolt
- 3 Copy hole pattern, drill 7 mm hole [2x]



Copying hole pattern

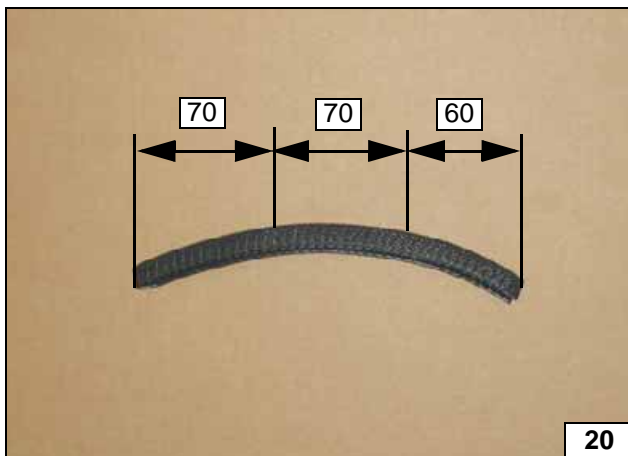

Cut edge protection to length as shown



Cutting edge protection to length

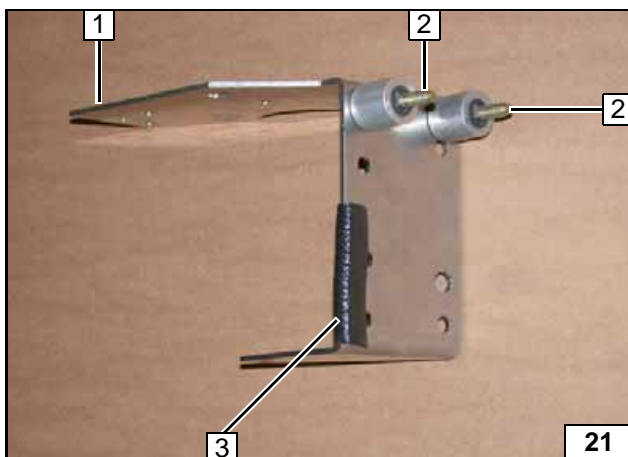

Preparing and installing bracket

- 1 Bracket
- 2 M6x35 bolt, 20 mm spacer, pin lock [2x each]
- 3 60 mm edge protection

Preparing bracket

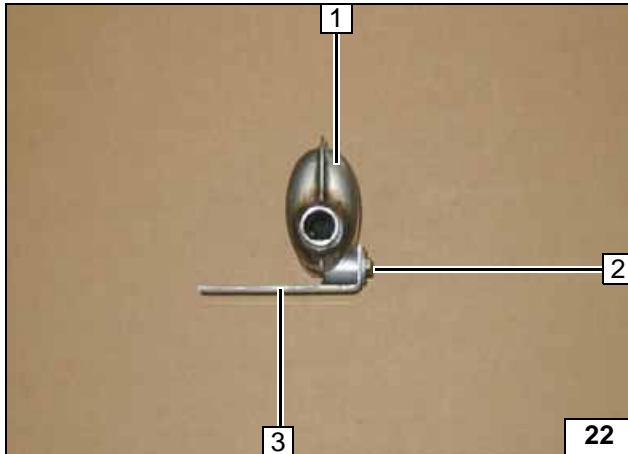
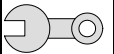

- 1 Exhaust muffler
- 2 M6x35 bolt, large diameter washer, 20 mm shim, flanged nut
- 3 Angle bracket

Preassembling exhaust muffler

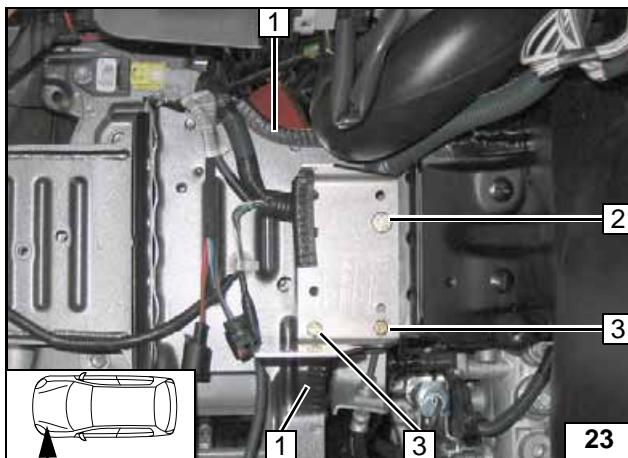

A 20 mm spacer must be positioned between bracket and vehicle at position 2

- 1 Edge protection 70 mm long [2x]
- 2 M8x40 bolt, spring lockwasher, existing threaded hole
- 3 M6x35 bolt, M6 flanged nut [2x each]

Installing bracket

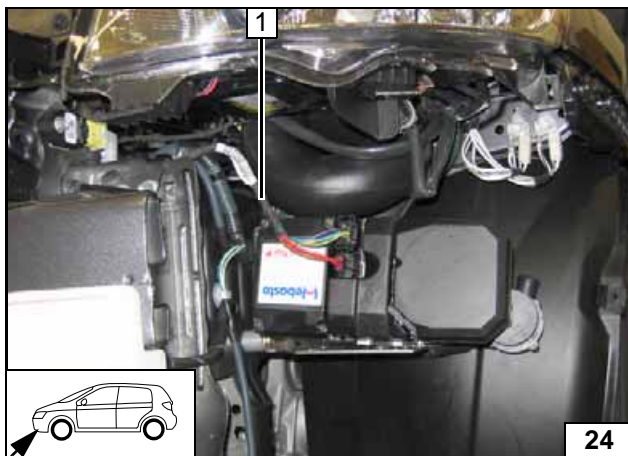

Installing heater

Wiring harness 1 must be connected before fastening heater.

Connecting wiring harness

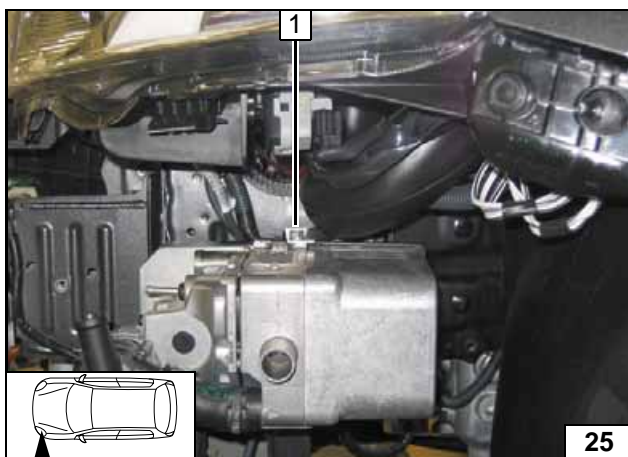

- 1 Loosely mount Eject screw

Installing heater

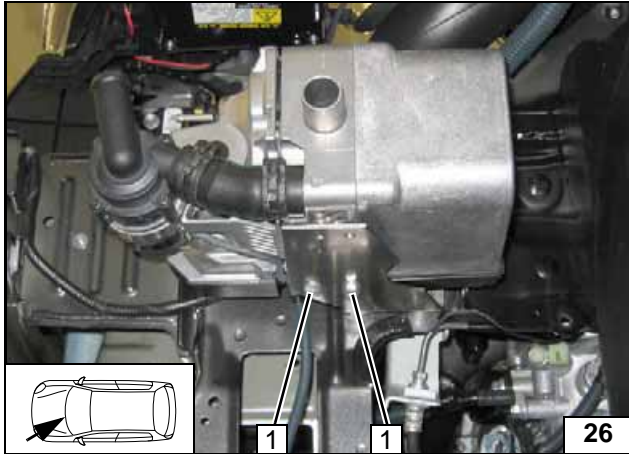
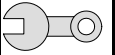

1 Loosely mount E-jot screw [2x]

Installing heater

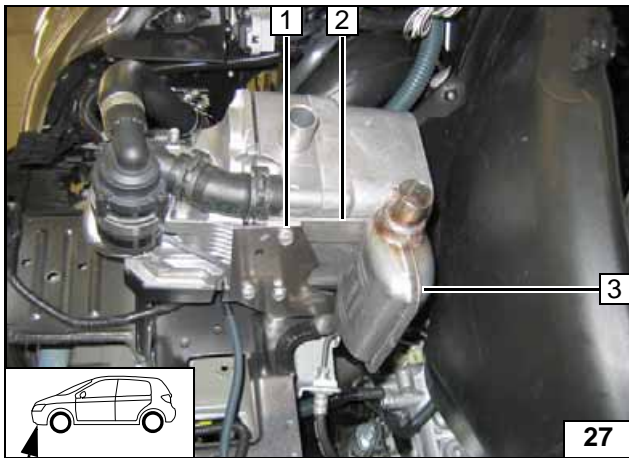

Position angle bracket 2 between heater and bracket. Tighten all E-jot screws.

- 1 E-jot screw
- 3 Preassembled exhaust muffler



Installing heater and exhaust muffler

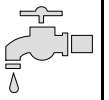



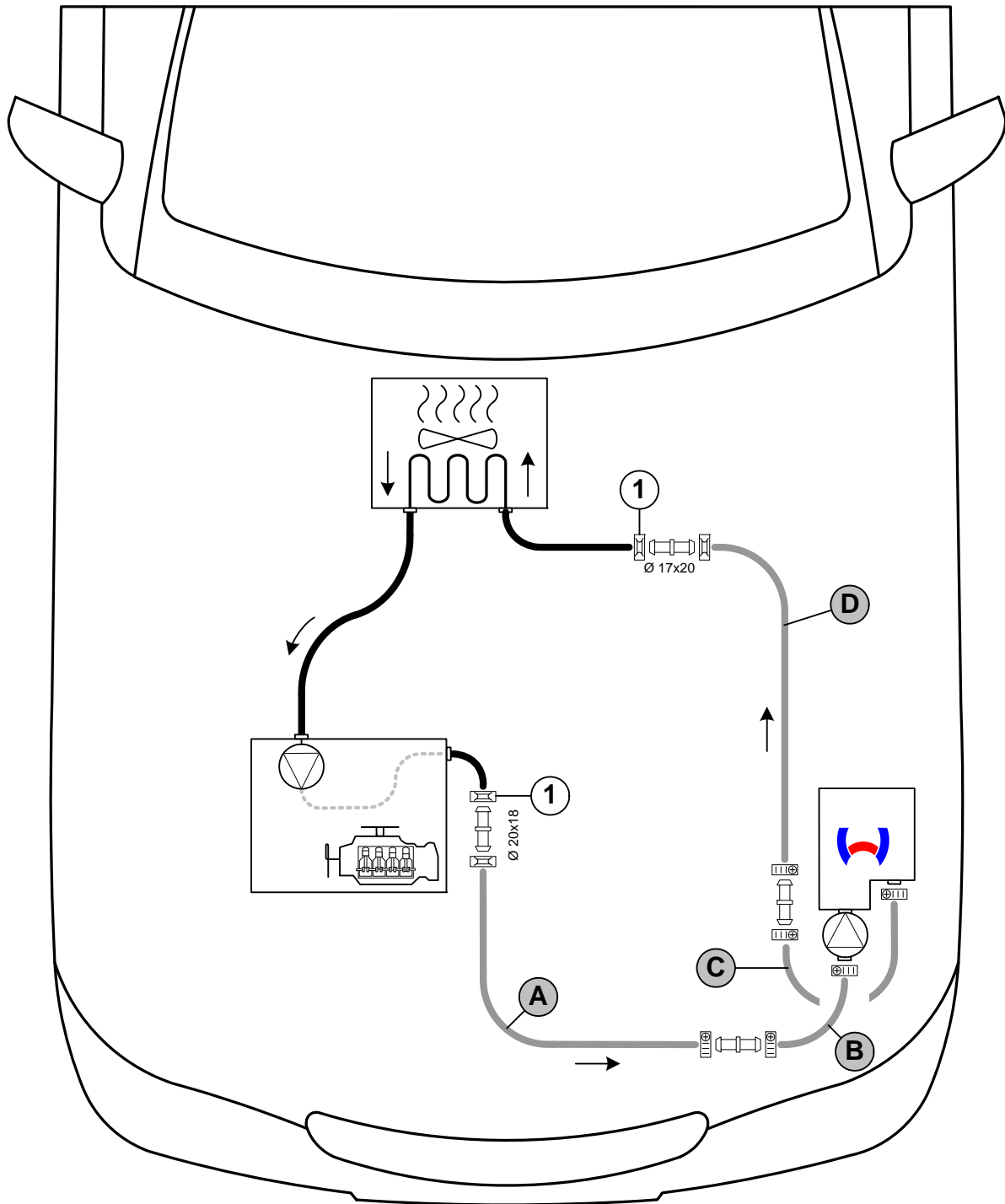

Coolant circuit 1.4 D

WARNING!

Any coolant running off should be collected using an appropriate container! Install hoses so that they are kink-free. Unless specified otherwise, always fasten using cable ties. Position clamps so that no other hose can be damaged! When installing the hoses, the heater must be filled with coolant. The connection should be "inline" based on the following diagram:



Hose routing diagram

All spring clips without a specific designation  = 27 mm dia. **1** = Original vehicle spring clip  .
 All connecting pipes without a specific designation  = dia. 20x20!
 All hose clamps without a specific designation  = 20-27 mm dia.



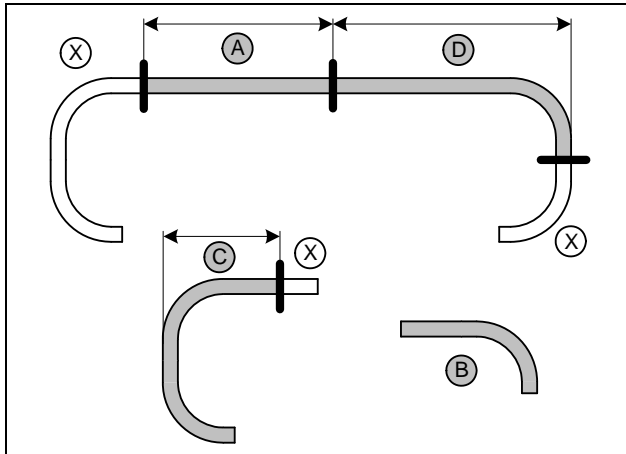
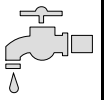

Discard section **X**.
C 20x20 90° moulded hose
C 20x20 180° moulded hose

up to MJ 2009

A = 850
C = 140
D = 950

from MJ 2010

A = 750
C = 140
D = 950



Cutting hoses to length

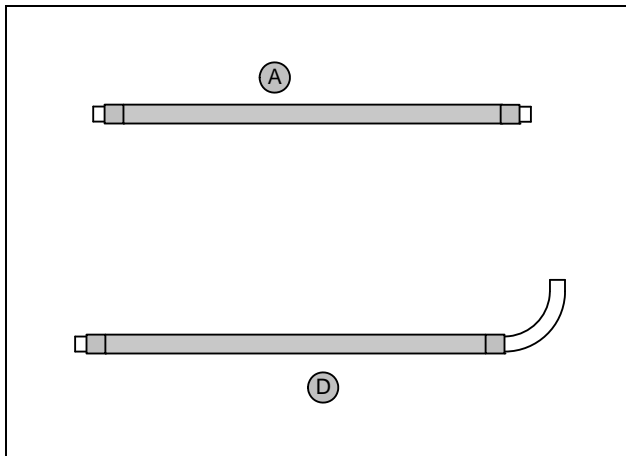

Push braided protection hoses onto hose **A** and **D** and cut to length.
 Cut heat shrink plastic tubing to length.

1 25 mm heat shrink plastic tubing [4x]



Preparing hoses

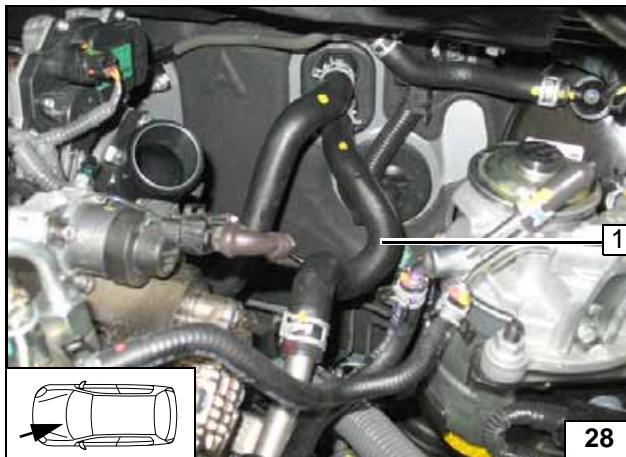

Remove hose at heat exchanger input **1**. The spring clips will be required later!



Cutting point

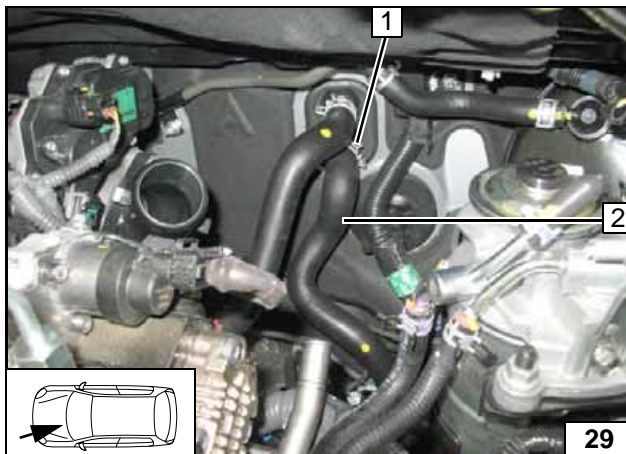

Install hose at heat exchanger input **1** laterally reversed

1 Original vehicle spring clip



Cutting point

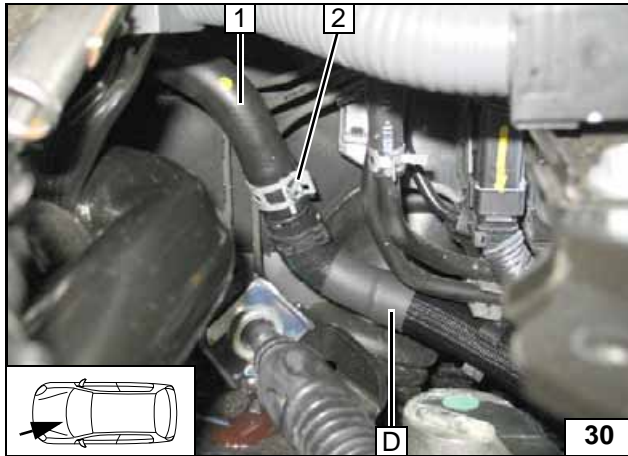

- 1 Hose on heat exchanger inlet
- 2 Original vehicle spring clip

Connect-
ing heat
exchanger
inlet

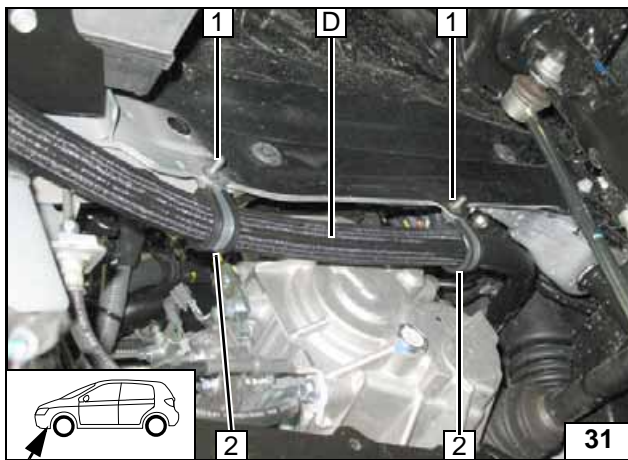

- 1 M6x20 bolt, rubber-coated p-clamp 2, pin lock, existing hole [2x each]

Install-
ing
hose E

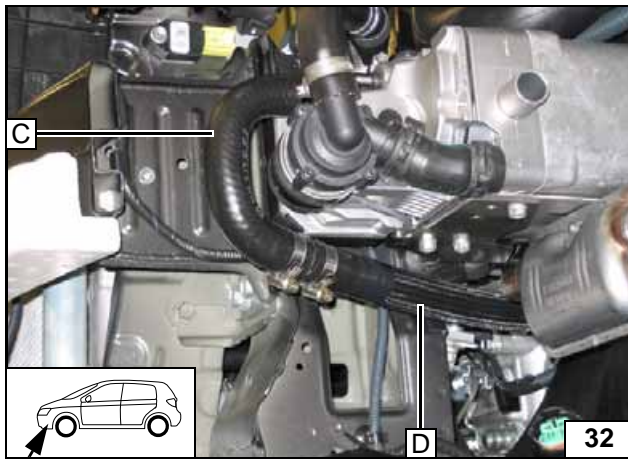

Install-
ing
hose D and
C

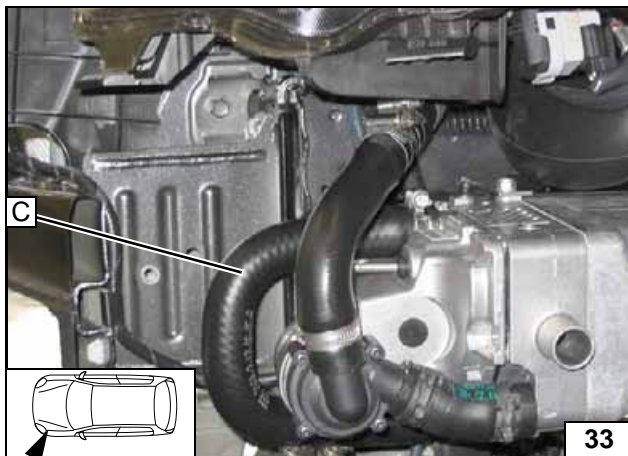

Connect-
ing heater
outlet

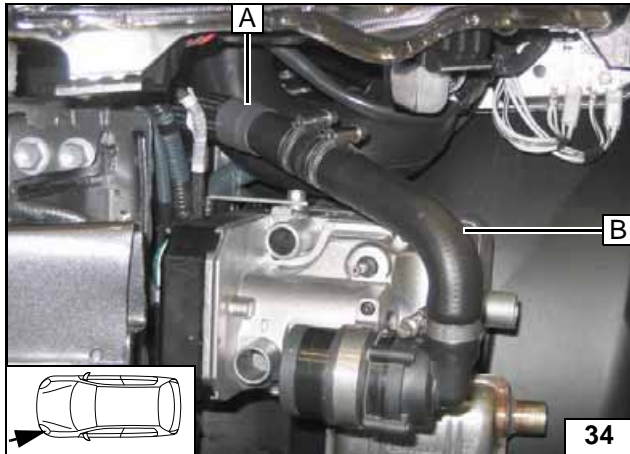

Connect-
ing heater
inlet

1 Cable tie

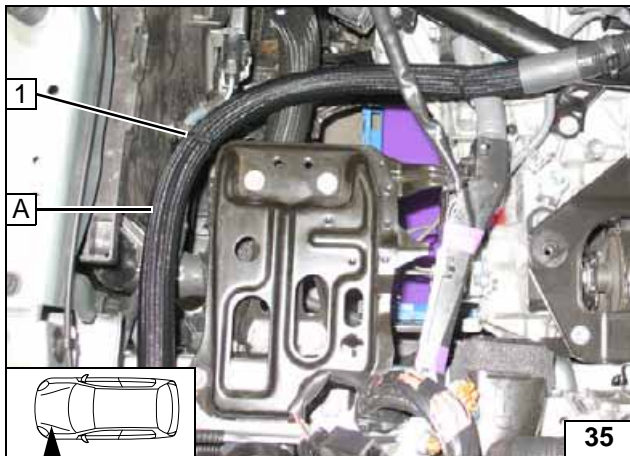

Routing in
engine
compart-
ment

Pull out hose of engine outlet 1 from pipe neck 2 and turn by approx. 180° at the front.



3 Original vehicle spring clip

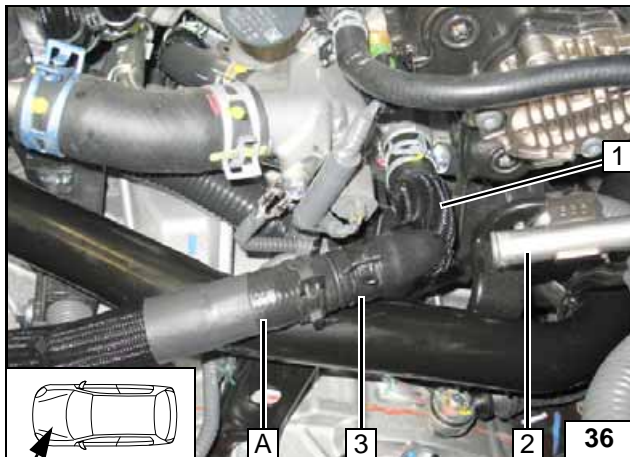

Connect-
ing engine
outlet

Ensure sufficient distance to neighbouring components.



1 Spacer bracket

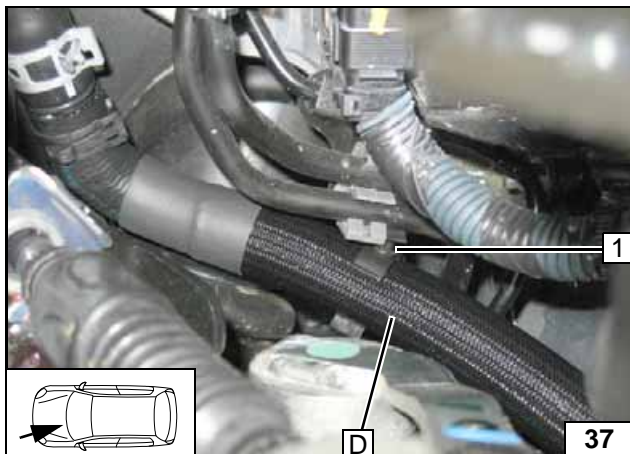

Installing
spacer
bracket

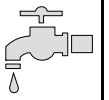



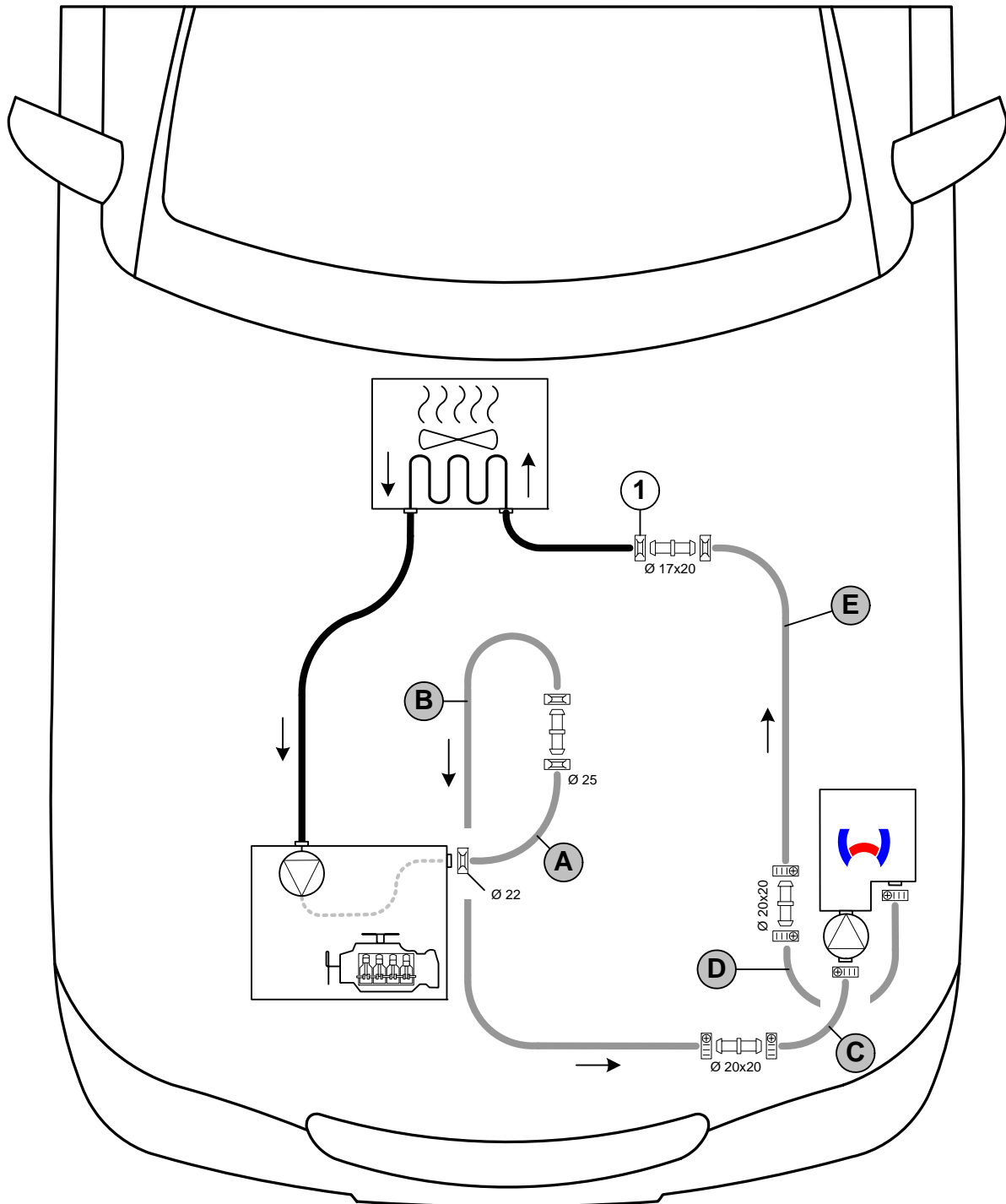

Coolant circuit 2.0 and 2.2 D

WARNING!

Any coolant running off should be collected using an appropriate container! Install hoses so that they are kink-free. Unless specified otherwise, always fasten using cable ties. Position clamps so that no other hose can be damaged! When installing the hoses, the heater must be filled with coolant. The connection should be "inline" based on the following diagram:



Hose routing diagram

All spring clips without a specific designation  = 27 mm dia. **1** = Original vehicle spring clip  .
 All connecting pipes without a specific designation  = dia. 18x20.
 All hose clamps without a specific designation  = 20-27 mm dia.



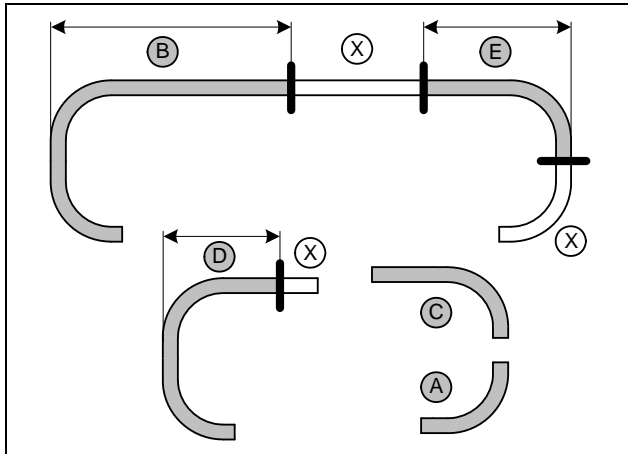

Discard section **X**.
A 15x18 90° molded hose provided
C 20x20 90° molded hose provided
D 20x20 180° molded hose provided

B = 970
D = 140
E = 630



Cutting coolant hoses to length

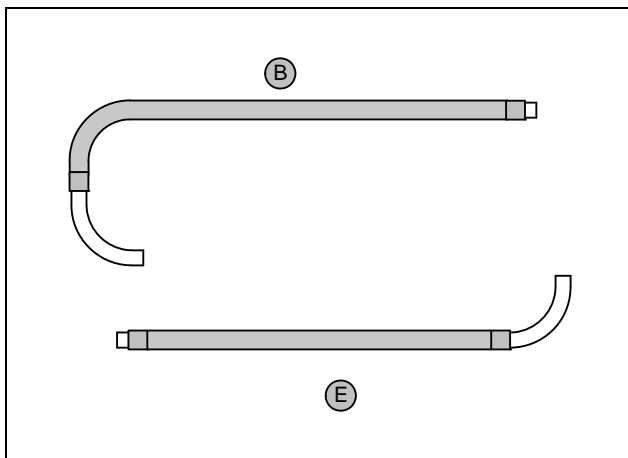

Push braided protection hose onto hose **B** and **E** and cut to length.
 Cut heat shrink plastic tubing to length.

1 25 mm heat shrink plastic tubing [4x]



Preparing coolant hoses

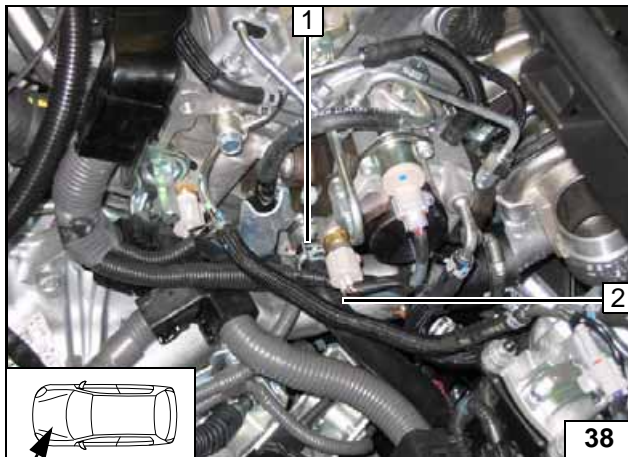

Pull off hose at heat exchanger input **2** from engine outlet. Spring clip **1** will be reused!



Cutting point

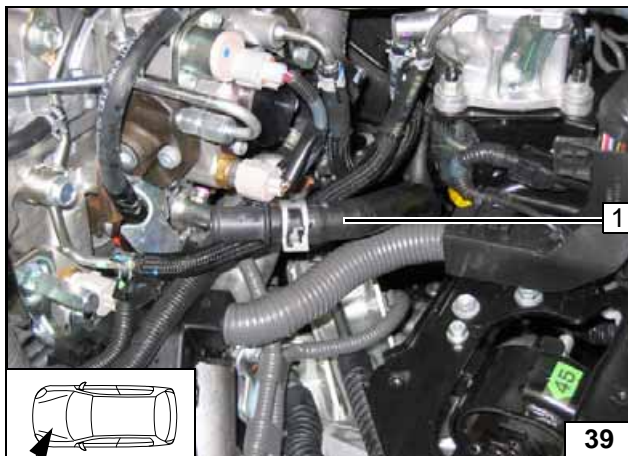

Preassemble hose of heat exchanger inlet **1** as shown and then route to firewall.



Preparing hose of heat exchanger inlet

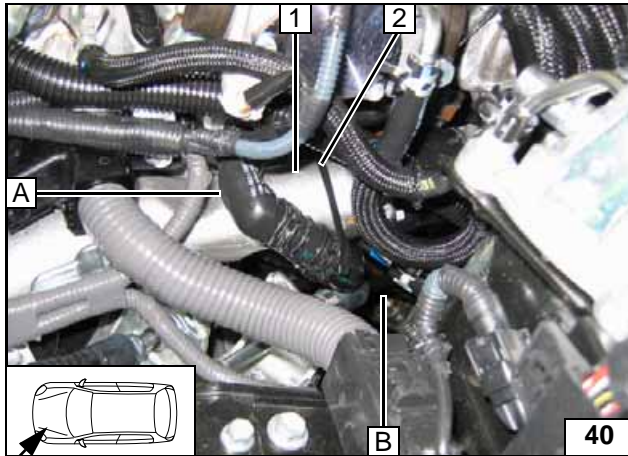
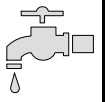

Route hose **B** between engine and charge-air tube **1** to radiator and connect to hose **A**.

2 Cable tie



Connect-
ing engine
outlet

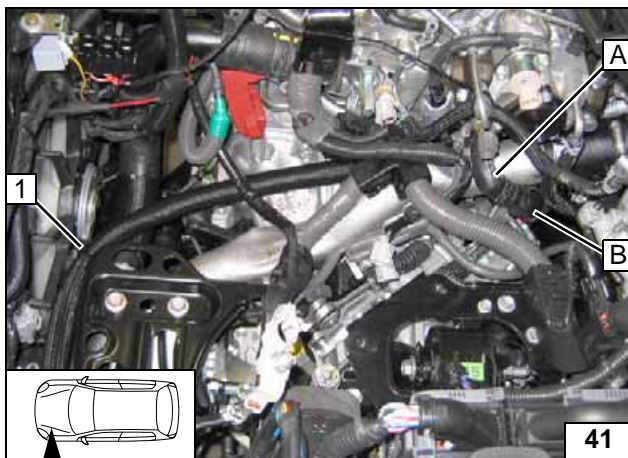

1 Cable tie

Routing in
engine
compart-
ment

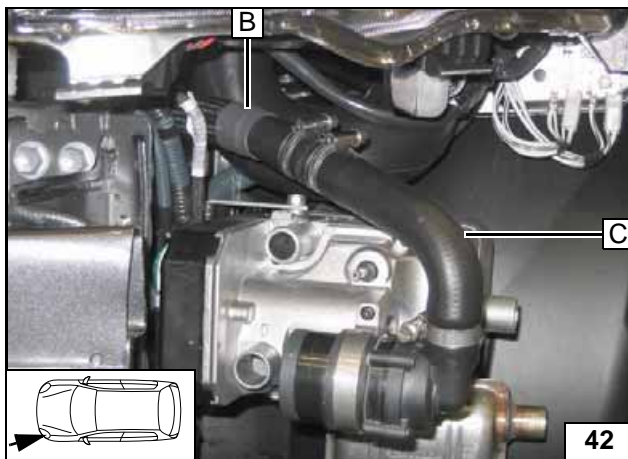

Connect-
ing heater
inlet

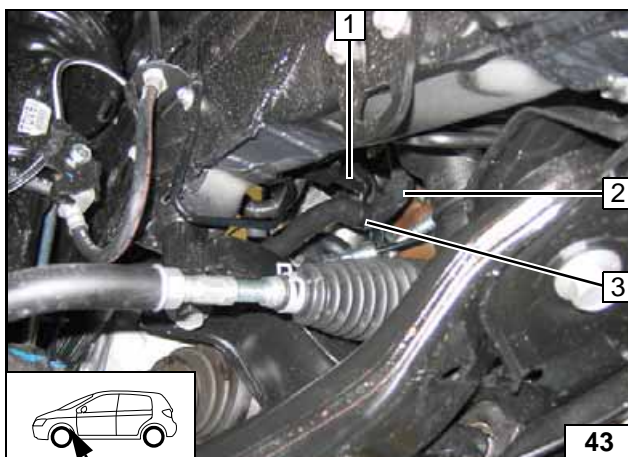

1 Original vehicle fuel line
2 Hose on heat exchanger inlet
3 Hose bracket

Fastening
hose to
heat ex-
changer in-
let

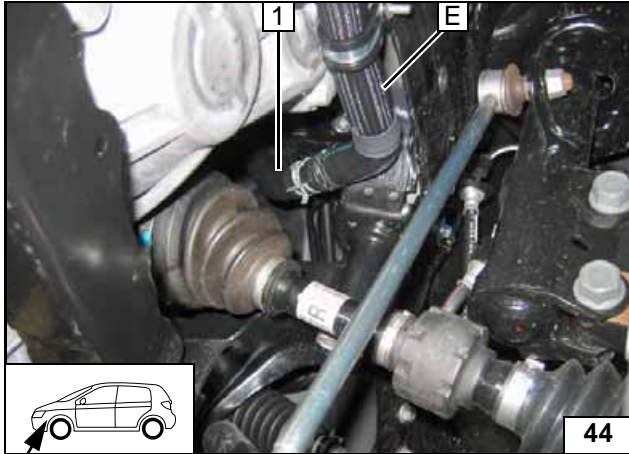

1 Hose on heat exchanger inlet

Connec-
tion to
hose E

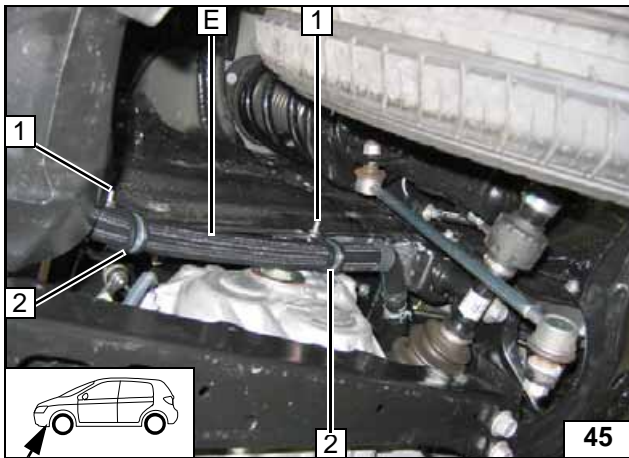

1 M6x20 bolt, rubber-coated p-clamp 2, pin lock, existing hole [2x each]

Installing
hose E

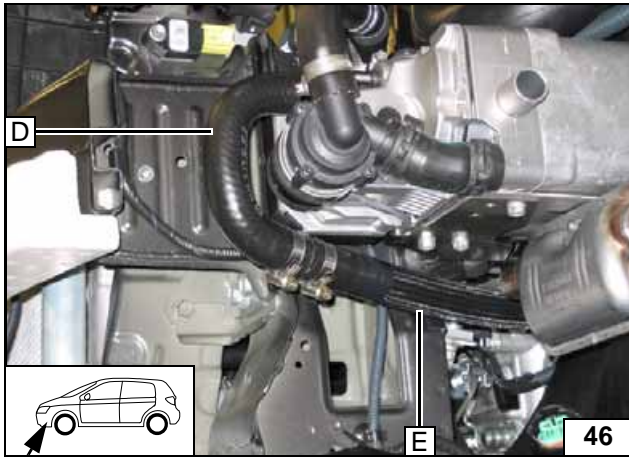

Installing
hose D and
E



Ensure sufficient distance to neighbouring components.



Connect-
ing heater
outlet



Fuel

CAUTION!

Open the vehicle's fuel tank cap, ventilate the tank and then re-close the tank lock.

Catch any fuel running off with an appropriate container.

Install fuel line and metering-pump wiring harness so that they are protected against stone impact. Unless specified otherwise, always fasten using cable ties. Mount the fuel line and wiring harness with rub protection on sharp edges.

WARNING!

The fuel line and wiring harness are routed to the metering pump in as shown in the wiring harness routing diagram.

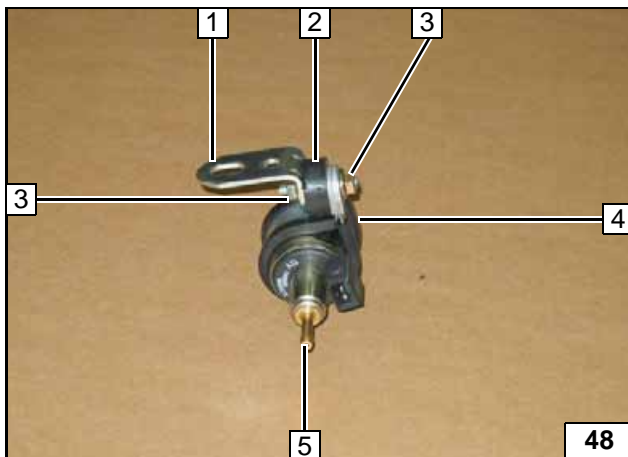

- 1 Angle bracket
- 2 Silent block
- 3 M6 flanged nut [2x]
- 4 Rubber-coated pipe clamp
- 5 Metering pump

Premounting metering pump

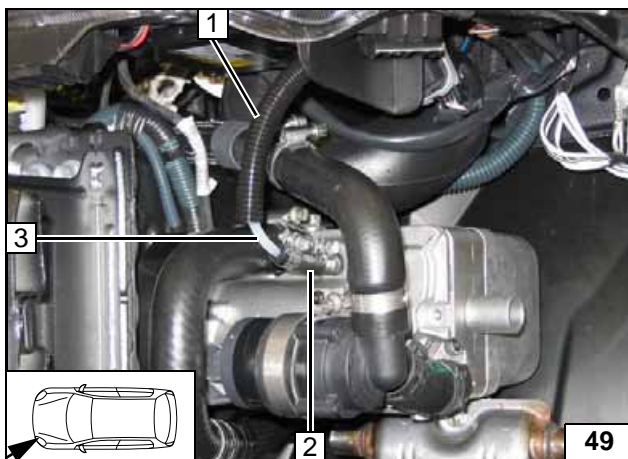

Connect fuel line 3 to heater and pull into 10 mm dia. corrugated tube 1.

- 2 Hose section, 10 mm dia. clamp [2x]



Connection to heater

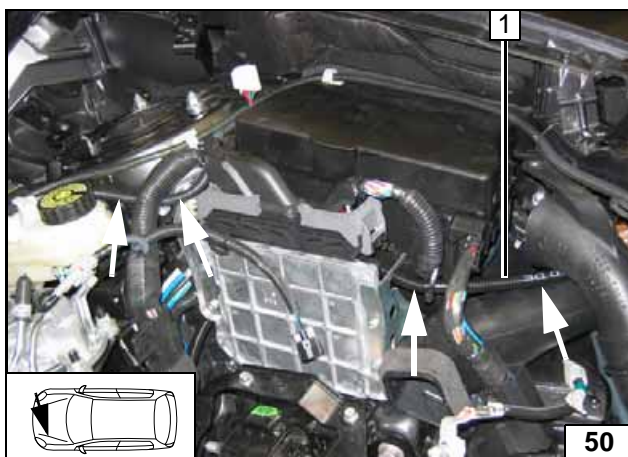

Route corrugated tube with fuel line 1 to firewall. Route wiring harness of metering pump and fuel line in second section of 10 mm dia. corrugated tube from firewall



Installing lines

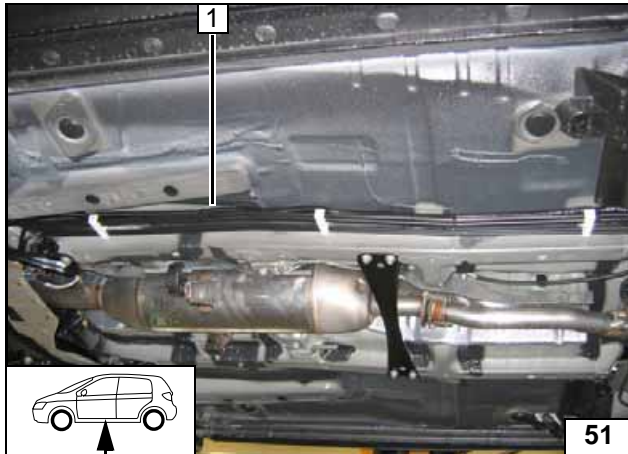

Route wiring harness of metering pump and fuel line in second section of 10 mm dia. corrugated tube **1** along original vehicle fuel lines to installation location of metering pump and fasten with cable tie.



Installing lines

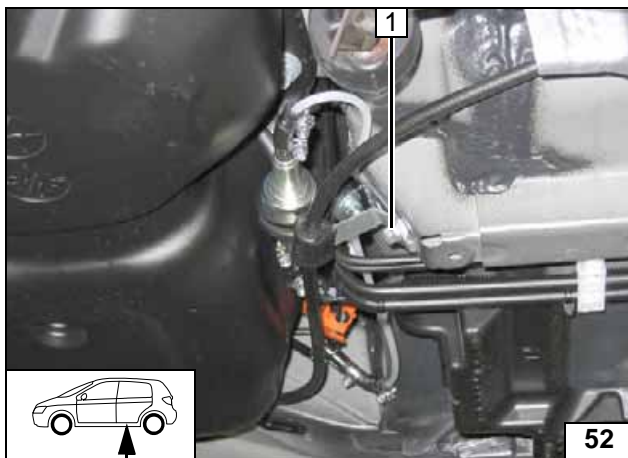

Installation location in front of vehicle fuel tank!



1 Original vehicle bolt

Installing metering pump

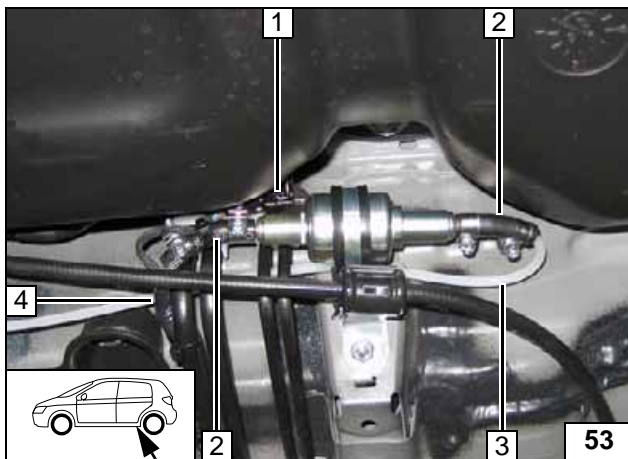

Check the position of the components; adjust if necessary. Check that they have free clearance.



Connecting metering pump

- 1** Wiring harness of metering pump, connector mounted
- 2** Hose section [2x], 10 mm dia. clamp [4x]
- 3** Fuel line
- 4** Corrugated tube with fuel line and wiring harness for metering pump

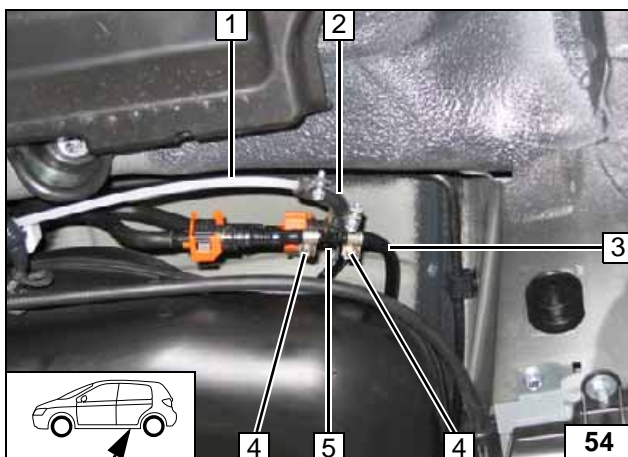

- 1** Fuel line
- 2** Hose section, 10 mm dia. hose clamp [2x]
- 3** Original vehicle fuel return line
- 4** 8 mm dia. hose clamp [2x]
- 5** 6x5x6 fuel standpipe

Mounting fuel standpipe

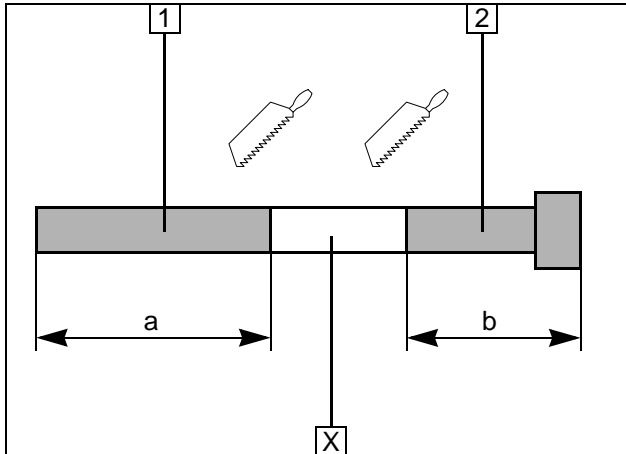
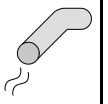

Exhaust gas

- 1 Exhaust pipe
a = 210
- 2 Exhaust end section
b = 260

Discard section X

Preparing exhaust pipe

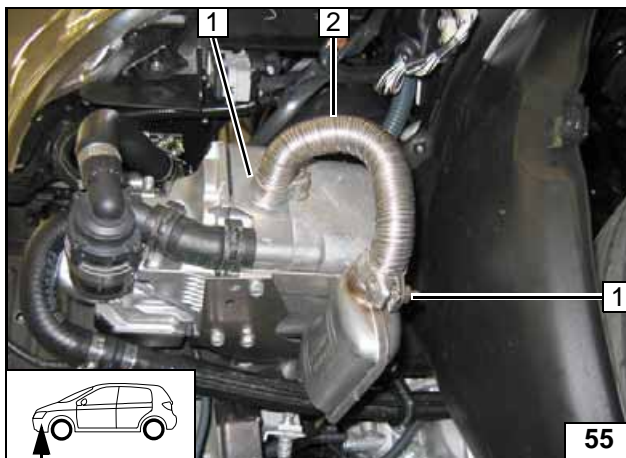

- 1 Hose clamp [2x]
- 2 Exhaust pipe

Installing exhaust pipe

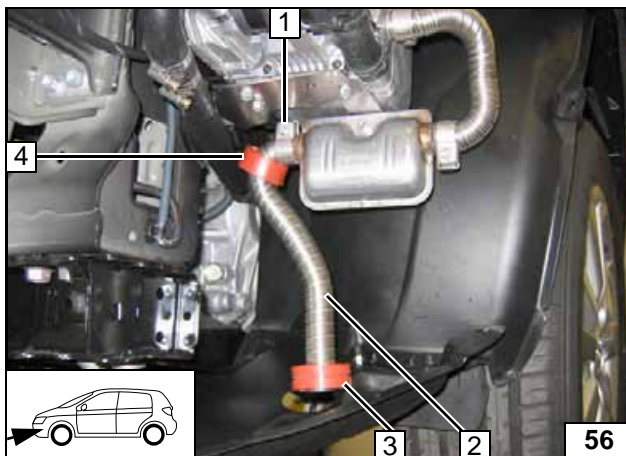

- 1 Hose clamp
- 2 Exhaust end section
- 3 Red (rt) rubber isolator with groove
- 4 Position red (rt) rubber isolator

Installing end section

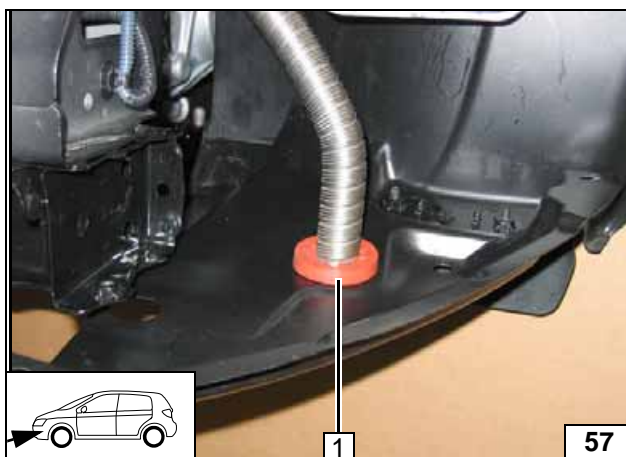

Drill out existing hole to 42 mm dia. 1 and mount exhaust end section with red (rt) rubber isolator with groove.



Installing exhaust end section

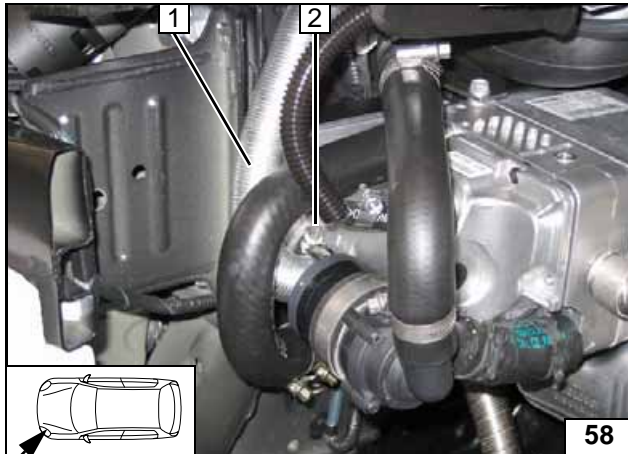
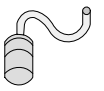

Combustion air

- 1 Combustion-air intake pipe
- 2 27 mm dia. hose clamp

Cutting combustion air pipe to length

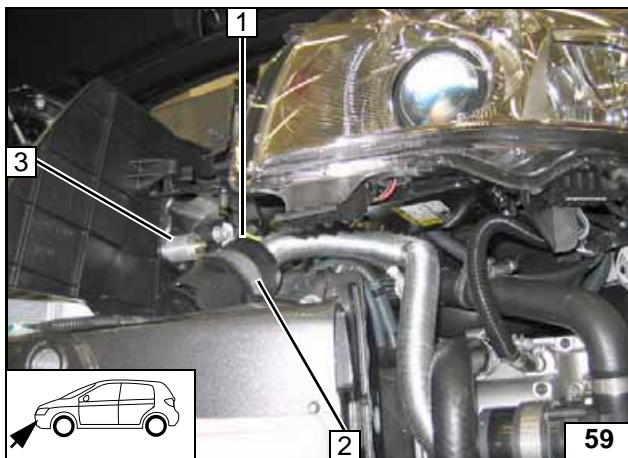

up to MY 2009

- 1 Muffler
- 2 51 mm dia. p-clamp
- 3 M5x35 bolt, large diameter washer, 15 mm shim, flanged nut



Installing muffler

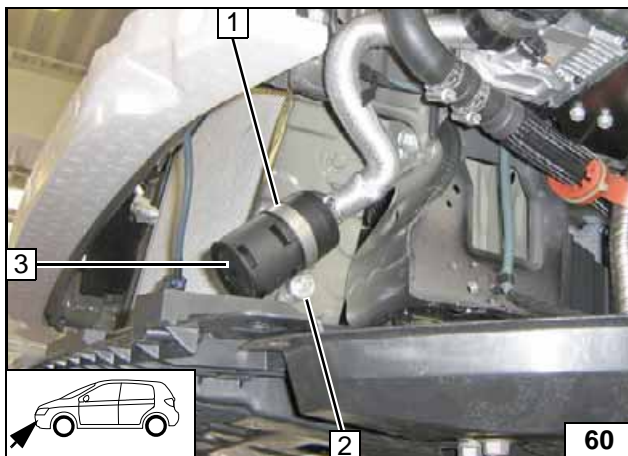

from MY 2010

Mount M6 rivet nut in existing hole at Position 2.

- 1 51 mm dia. p-clamp
- 2 M6x30 bolt, 15 mm shim
- 3 Muffler



Installing muffler

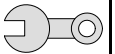

Final Work

WARNING!

Reassemble the disassembled components in reverse order.
 Check all hoses, clamps and all electrical connections for firm seating.
 Secure all loose cables using cable ties.
 Only use manufacturer-approved coolant.
 Spray the heater components with anti-corrosion wax (Tectyl 100K, Order No. 111329).

- Connect the battery
- Fill and bleed the coolant circuit according to the vehicle manufacturer's specifications.
- Adjust digital timer, try out Telestart
- Make settings on A/C control panel according to the "Operating Instructions for End Customer".
- Mount information label "Switch off parking heater before refueling" in area of filler neck.
- Check the proper operation of the parking heater, see the operating instructions/installation instructions.

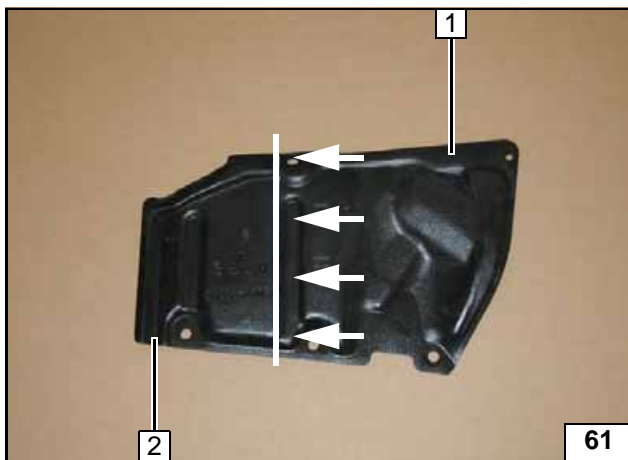

Shorten side wheel well trim 1 according to figure.

2 Discard section

Shortening side wheel well trim

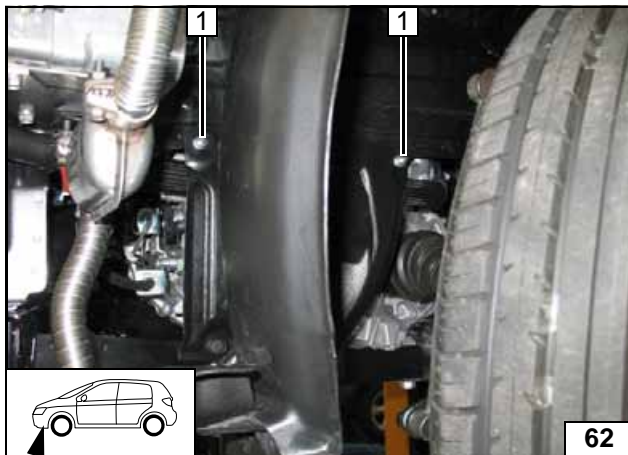

1 M6 flanged nut [2x]

Installing side wheel well trim



Webasto AG
 Postfach 80
 D-82131 Stockdorf / Germany
 National Hotline: 01805 93 22 78
 (14 Cent aus dem deutschen Festnetz)
 Hotfax: 0395 5592 353
 Hotmail: hotline@webasto.de
<http://www.webasto.de>

Operating Instructions for End Customer

Please remove page and add to the vehicle operating instructions.



Note:

We recommend matching the heating time to the driving time.

Heating time = driving time

Example:

For a driving time of approx. 20 min. (in one direction), we recommend not exceeding a switch-on time of 20 min.

If the summer/winter switch option has been installed, this must be switched in accordance with the time of year. The heater will then only switch on the vehicle fan to ventilate the vehicle interior in the position Winter  heat and in the position Summer .

Before parking the vehicle, make the following settings:



No display appears in A/C control panel during heating!

Order of setting:

1. Air outlet at windshield
2. Set fan to level "2"
3. Set temperature to "HI"

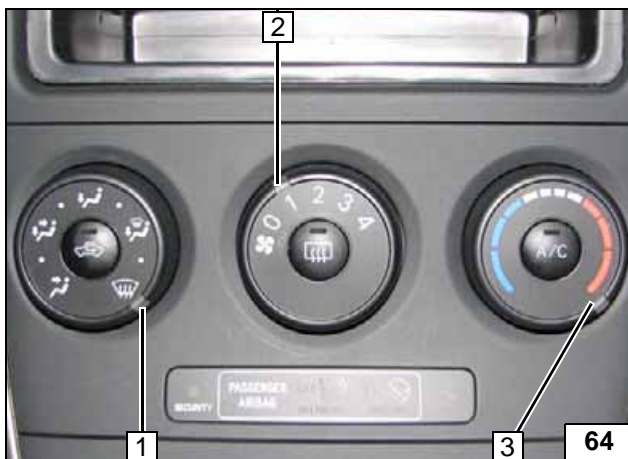

Order of setting:

1. Air outlet at windshield
2. Set fan to level "1"
3. Set temperature to "max."



Automatic air-conditioning

Manual air conditioning