

Water Heater



Thermo Top E Parking Heater

00 0003

Thermo Top C Parking Heater

00 0002

Thermo Top P Parking Heater

00 0104

Installation documentation

Mazda 2

Gasoline

from Model Year 2008

Left-hand drive vehicle



WARNING!

Hazard warning:

Incorrect installation or repair of Webasto heating systems may cause a fire or result in the emission of carbon monoxide, which can be fatal. Serious or fatal injuries can be caused as a result.



Specialist company training, technical documentation, specialised tools and equipment are required to install and repair Webasto heating and cooling systems.

Only original Webasto parts must be used. For this, also see the catalog of air and water heater accessories from Webasto.

NEVER attempt to install or repair Webasto heating or cooling systems if you have not successfully completed the company training and thereby acquired the required technical skills, or if you do not have access to the required technical documentation, tools and equipment needed to carry out correct installation and repairs.

ALWAYS follow all Webasto installation and repair instructions and observe all warnings.

The initial startup is to be executed with the Webasto Thermo Test Diagnosis.

Webasto does not accept any liability for defects and damage that are attributable to installation by untrained staff.

Table of contents

Validity	2	Preparing installation location	11
Heater/installation kit	3	Installing heater	12
Foreword	3	Exhaust gas	13
General instructions	3	Fuel	15
Special tools	3	Combustion air	18
Explanatory notes on document	4	Coolant circuit	19
Preliminary work	5	Final Work	22
Heater installation location	5	Template for Fuel Standpipe	23
Electrical system	6	Operating Instructions for End Customer	24
Fan controller for manual air conditioning	7		
Automatic air-conditioning fan controller	8		
Digital timer and optional summer/winter switch	9		
Remote option (Telestart)	9		

Validity

Manufacturer	Model	Type	EG-BE No./ABE
Mazda	2	DE	e13 * 2001/116 * 0254 * ...

Engine type	Engine model	Output in kW	Displacement in cm ³
ZJ	Gasoline	55	1349
ZJ	Gasoline	63	1349
ZY	Gasoline	76	1498

Vehicle and engine types, equipment variants and national specifications not listed in this installation documentation have not been tested. However, installation according to this installation documentation may be possible.

The installation location of a digital timer and summer/winter switch should be confirmed with the end customer before installation.

Heater/installation kit

Quantity	Description	Order No.:
1	Retail accessories <i>Thermo Top E / C / P</i>	See Mazda price list
1	Installation kit for Mazda 2 Gasoline	1313228C
	Mazda Order No.:	4100-78-759A
1	Heater control	See Mazda price list

Heater recommended for the respective vehicle class:

Vehicle	Heater
Compact car	Thermo Top E
Mid-size car, station wagon	Thermo Top C
Full-size car, van, offroader	Thermo Top P

The selection of the heater is based on the passenger compartment size of the vehicle and the level of comfort required by the customer!

**Foreword**

This installation document applies to the Mazda 2 Gasoline vehicles - for validity, see page 2 - from model year 2008 and later, assuming technical modifications to the vehicle do not affect installation, any liability claims excluded. Depending on the vehicle version and equipment, modifications may be necessary during installation with respect to this installation documentation.

However, the stipulations in this "installation documentation" and the "operating and maintenance instructions" for the *Thermo Top C/P/E* must always be observed.

The corresponding rules of technology and any information from the vehicle manufacturer should be observed during the installation work.

General instructions

Installation should be carried out according to the general, standard rules of technology. Unless specified otherwise, fasten hoses, lines and wiring harnesses to original vehicle lines and wiring harnesses using cable ties.

Sharp edges must be provided with rub protection (cut-open fuel hose)!

Spray unfinished body areas, e.g. drilled holes, with anti-corrosion wax (Tectyl 100K, Order No. 111329).

Special tools

- Torque wrench for 2.0 - 10 Nm
- Hose clamping pliers
- Metric thread-setter kit

Explanatory notes on document

To provide you with a quick overview of the individual working steps, you will find an identification mark on the outside top right corner of the page in question.

Mechanical system

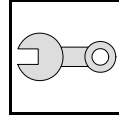

Electrical system

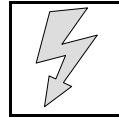

Coolant circuit

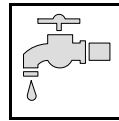

Fuel

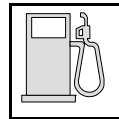

Exhaust gas

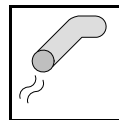

Combustion air

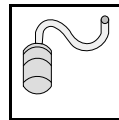

Special features are highlighted using the following symbols:



Specific risk of injury or fatal accidents.



Specific risk of damage to components.



Specific risk of fire or explosion.



Reference to general installation instructions of Webasto components or to the manufacturer's vehicle-specific documents.



Reference to a special technical feature.

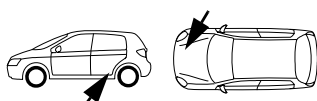

The arrow in the vehicle icon indicates the position on the vehicle and the viewing angle.

All dimensions are in mm!

Tightening torque of hose clamps = 2.0 + 0.5 Nm!

Tightening torque of Ejet screws, Ejet studs = 10 Nm!

Preliminary work

WARNING!

- Open the fuel tank cap and vent the fuel tank.
- Close the tank cap again.
- Disconnect the battery "earth" or "ground" connection.
- Depressurize the cooling system.
- Copy the factory number from the original type label to the duplicate type label.
- Remove years that do not apply from the duplicate label.
- Attach the duplicate label (type label) in the appropriate place.
- Completely remove the battery.
- Remove the air filter together with the intake hose
- Remove the override protection
- Remove the instrument panel trim on the driver's side.
- Expose the central electrical box on the driver's side.

Remove page 24 "Operating Instructions for End Customer" and attach to vehicle operating instructions.

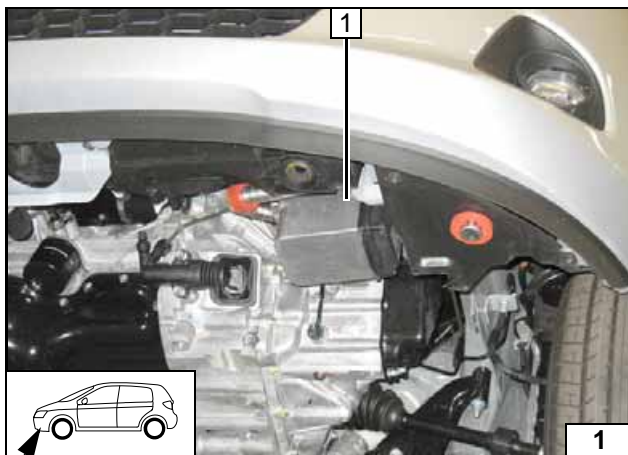

Heater installation location

1 Heater

Installation location



Electrical system

Preparing fuse holder, K3 relay

Cut away insulation mats (if present) at marking.

- 1 Discard section

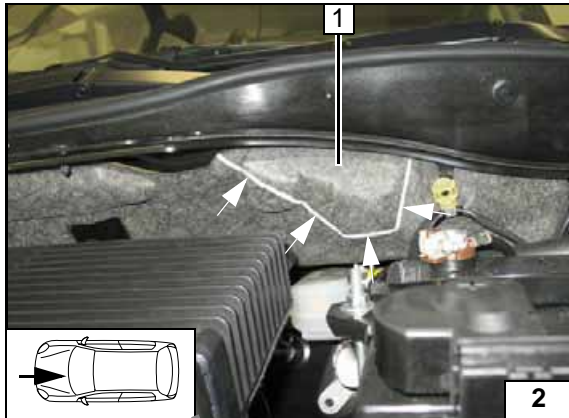

Fuse holder, K3 relay

- 1 4 mm dia. hole, 5.5x13 self-tapping screw, retaining plate of fuse holder on coolant reservoir
- 2 4 mm dia. hole, 5.5x13 self-tapping screw
- 3 K3 relay
- 4 Fuse holder

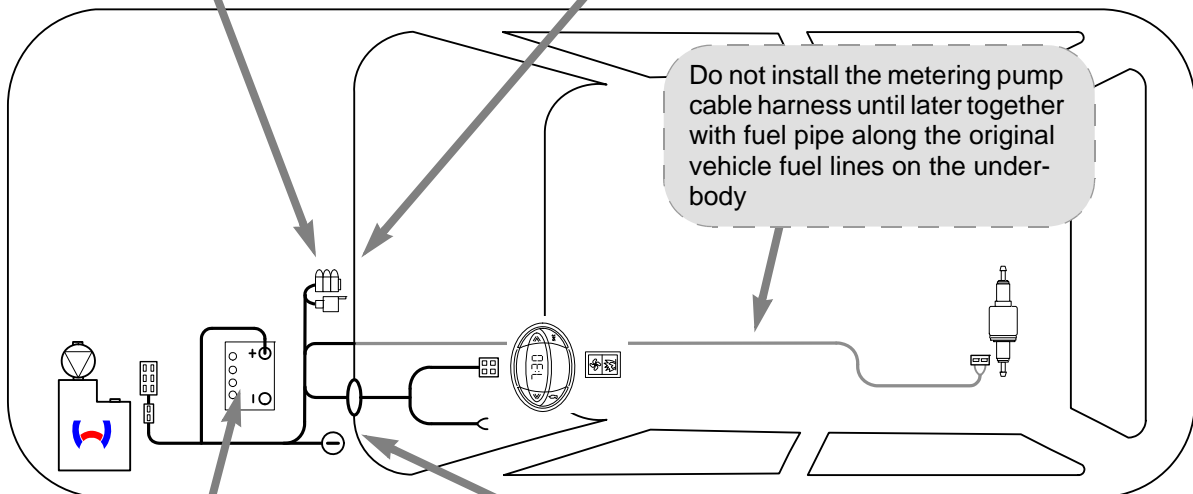
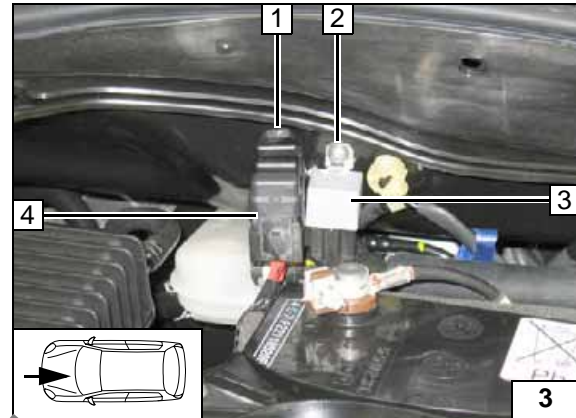

Wiring harness installation diagram



Positive wire

- 1 Positive wire on battery - positive distributor, tightening torque 8-13 Nm!

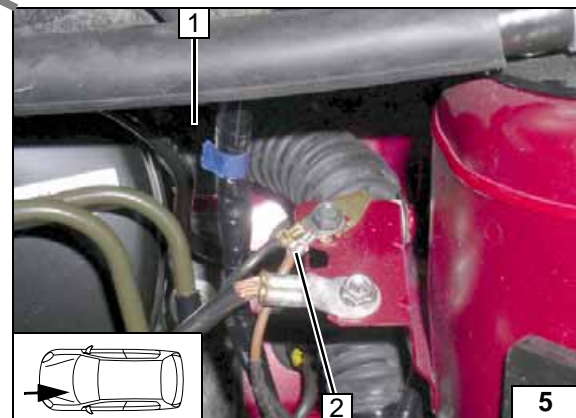

Wiring harness pass through, ground wire

- 1 Protective rubber plug
- 2 Ground wire on original vehicle ground point, tightening torque 8-13 Nm!



Fan controller for manual air conditioning

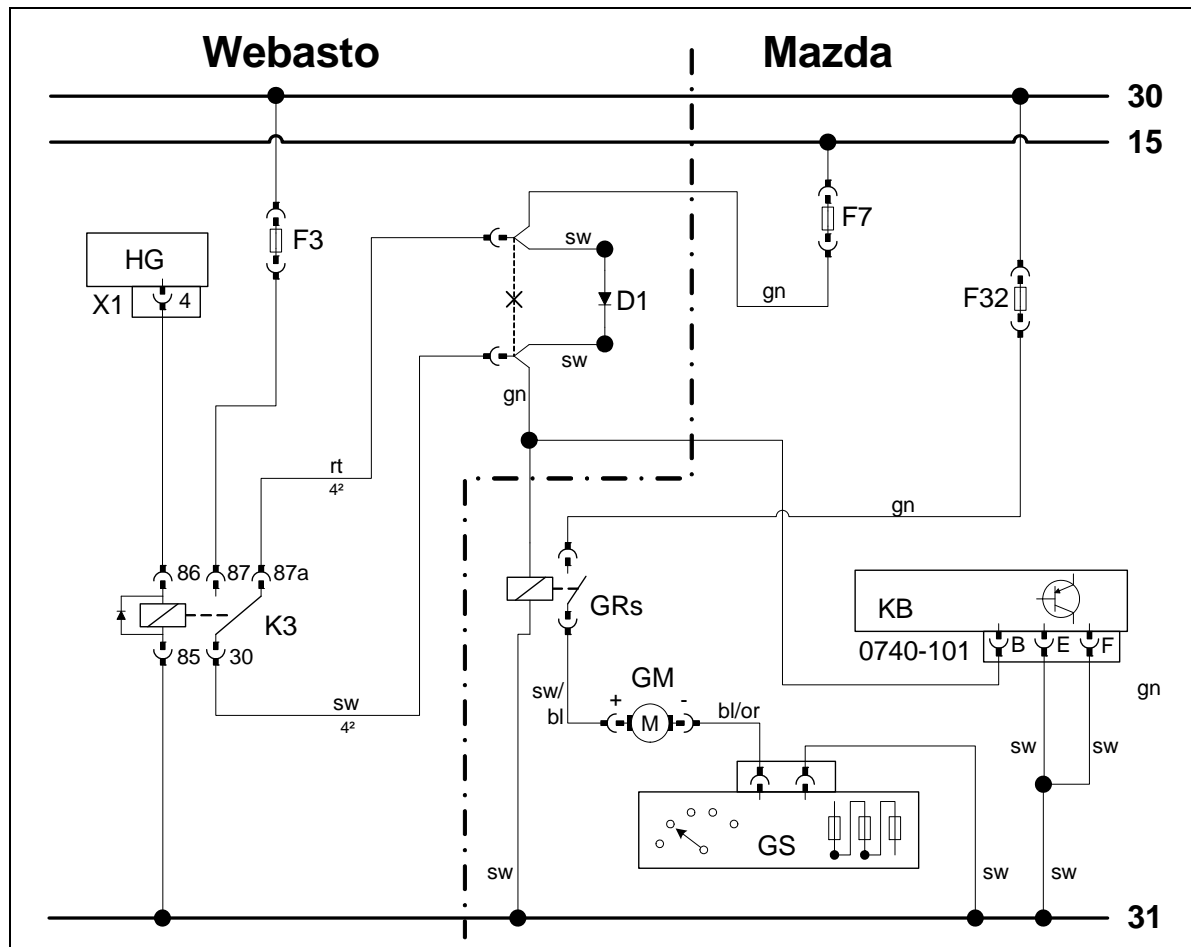

Wiring diagram

Webasto components		Vehicle components		Colours and symbols	
HG	Heater TT-C/E/P	GM	Fan motor	rt	red
X1	6-pin heater connector	GRs	Fan relay	or	orange
F3	Replace 25 A with 7.5A fuse.	GS	Fan switch/resistor group	sw	black
K3	Fan relay	KB	A/C control unit	bl	blue
D1	Diode 3A	F7	7.5 A A/C fuse	gn	green
		F32	30 A blower fuse		
				X	Cutting point
				Wiring colours may vary.	

Legends

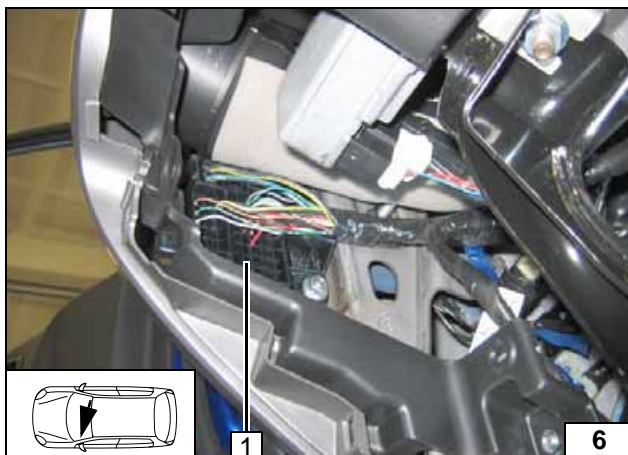

Connection on fuse box F02 1 of central electrical box.
Produce connections as shown in wiring diagram.



Installation location of central electrical box

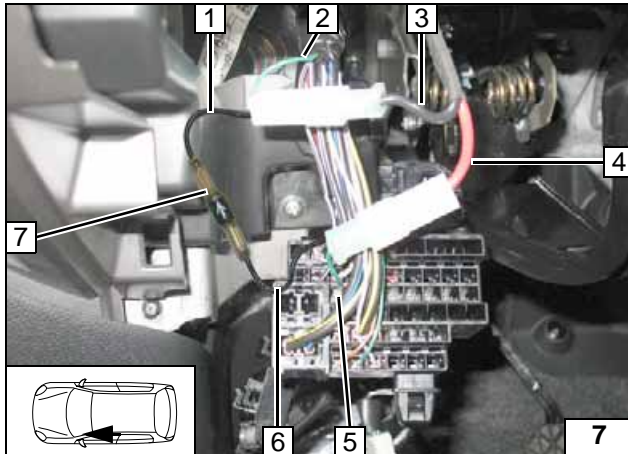

Pay attention to the through-flow direction of the diode 7.

- 1 Black (sw) wire on output of diode D1
- 2 Green (gn) wire of A/C control panel connector 0740-101, Pin B
- 3 Black (sw) wire from K3/30
- 4 Red (rt) wire from K3/87a
- 5 Green (gn) wire of fuse F7
- 6 Black (sw) wire on input of diode D1



Connecting central electrical box

Automatic air-conditioning fan controller

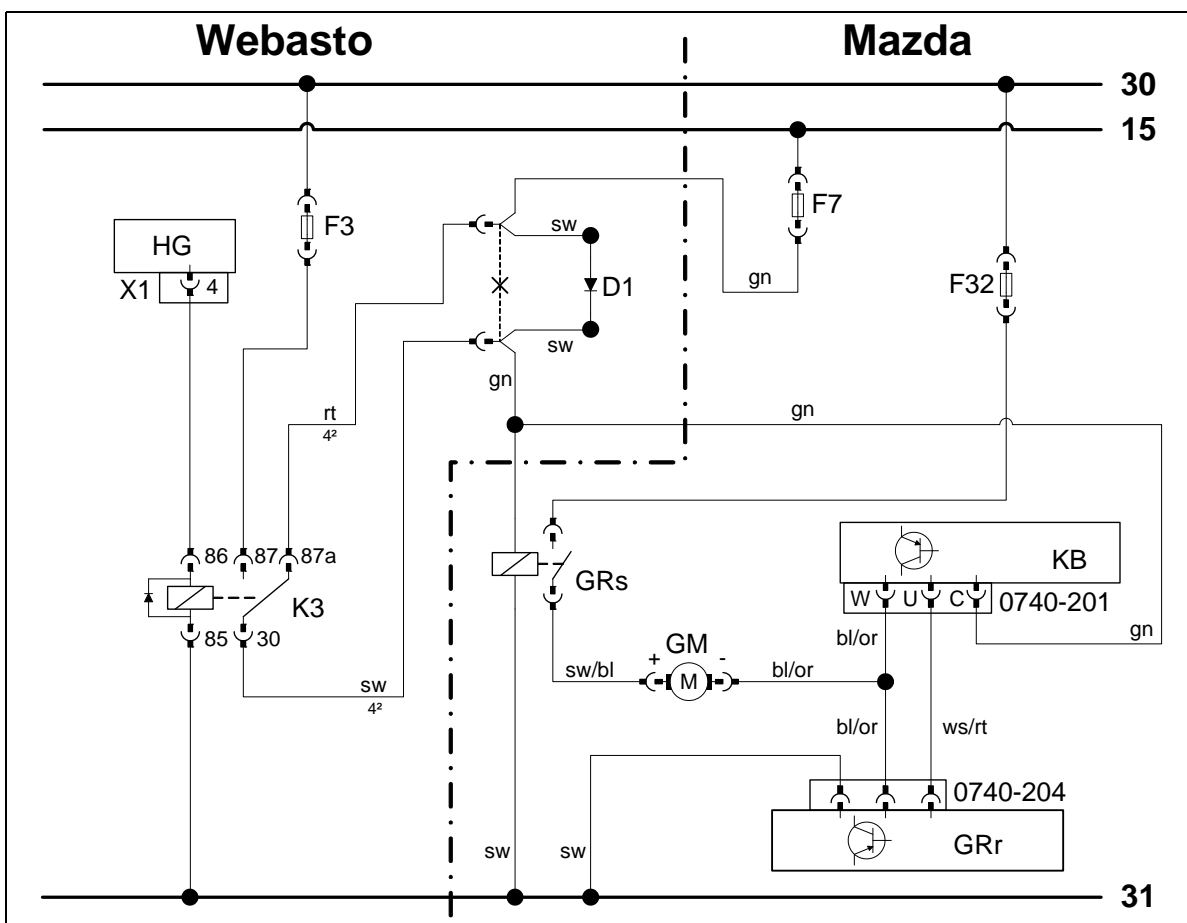

Wiring diagram

Webasto components		Vehicle components		Colours and symbols	
HG	Heater TT-C/E/P	GM	Fan motor	rt	red
X1	6-pin heater connector	GRs	Fan relay	ws	white
F3	Replace 25 A with 7.5A fuse.	GRr	Fan controller	sw	black
K3	Fan relay	KB	A/C control panel	bl	blue
D1	Diode 3A	F7	7.5 A A/C fuse	gn	green
		F32	30 A blower fuse	or	orange
				X	Cutting point
					Wiring colours may vary.

Legends

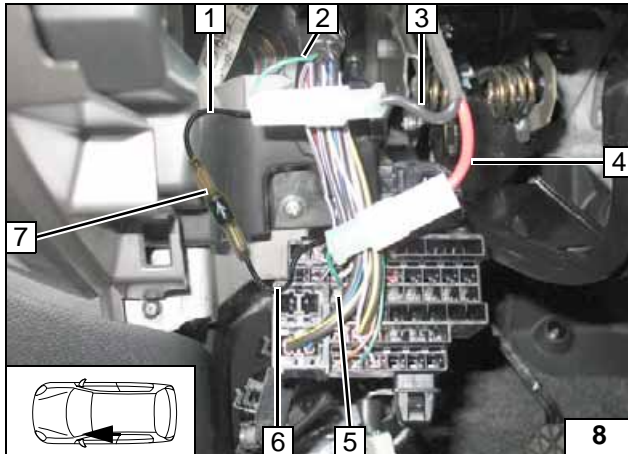
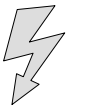

Pay attention to the through-flow direction of the diode 7.

- 1 Black (sw) wire on output of diode D1
- 2 Green (gn) wire of A/C control panel connector 0740-201, Pin C
- 3 Black (sw) wire from K3/30
- 4 Red (rt) wire from K3/87a
- 5 Green (gn) wire of fuse F7
- 6 Black (sw) wire on input of diode D1



Connecting central electrical box

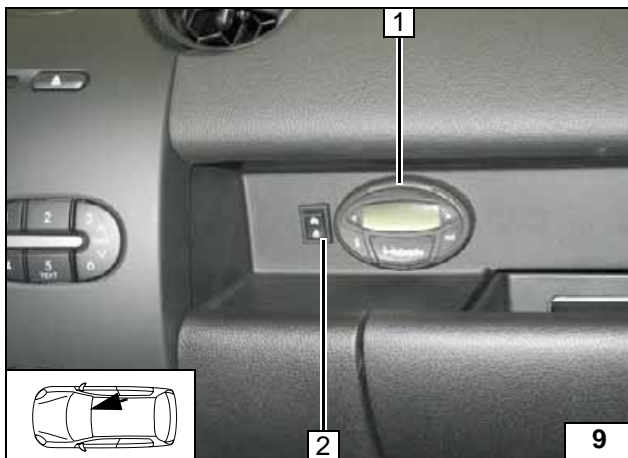

Digital timer and optional summer/winter switch

Up to model year 2009!

- 1 Digital timer
- 2 Summer/winter switch, drilled hole 12 mm dia.



Installing digital timer

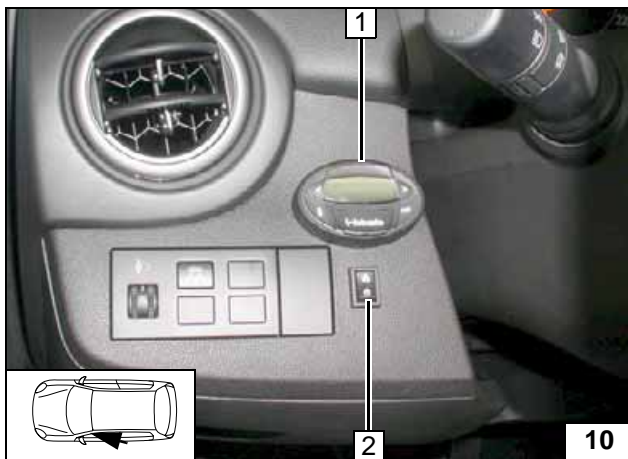

From model year 2010!

- 1 Digital timer
- 2 Summer/winter switch, drilled hole 12 mm dia.



Installing digital timer

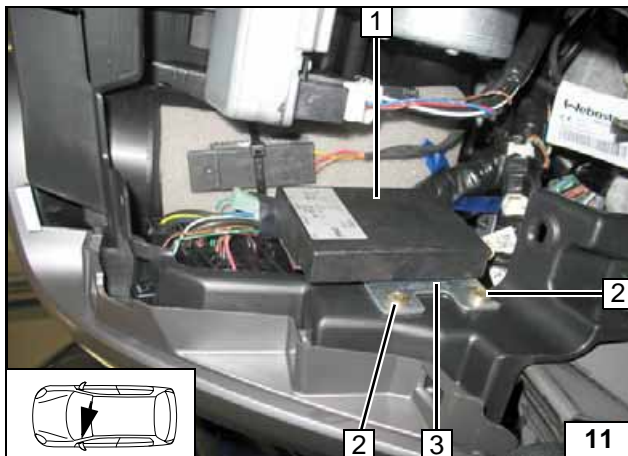

Remote option (Telestart)

Up to model year 2009!

- 1 Receiver
- 2 4 mm dia. hole, 5.5x9.5 self-tapping screw [2x each]
- 3 Bracket angled down by 90°



Installing receiver

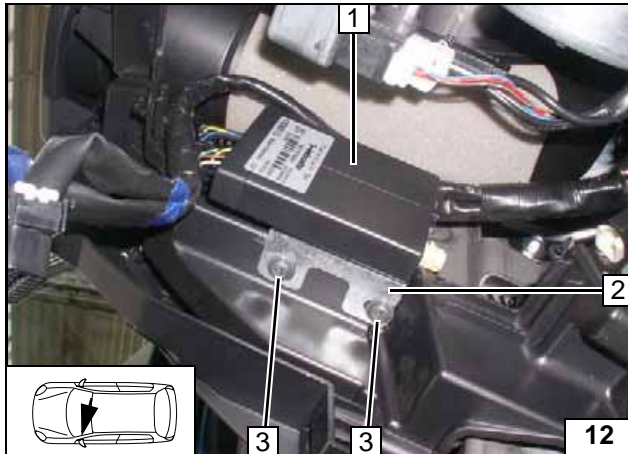

From model year 2010!

- 1 Receiver
- 2 Bracket angled down by 90°
- 3 4 mm dia. hole, 5.5x9.5 self-tapping screw [2x each]



Installing receiver

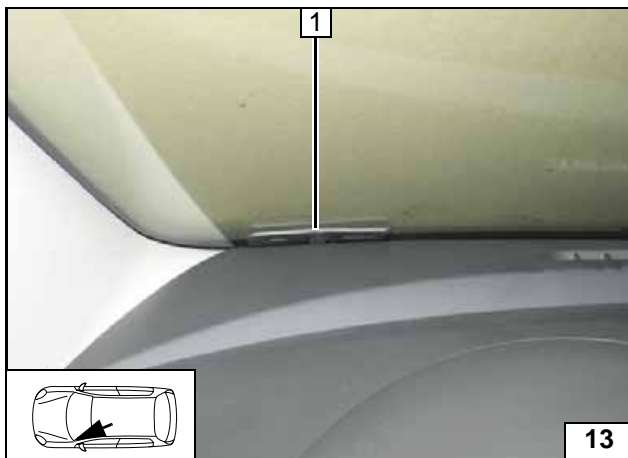

- 1 Antenna

Installing antenna

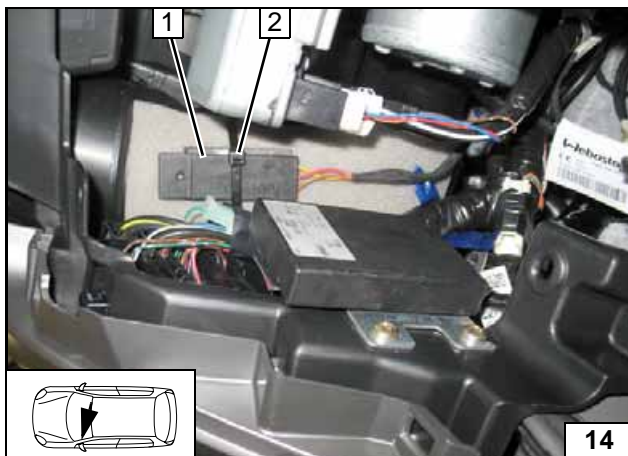

Temperature sensor T100 HTM

Figure shows model year 2009!

- 1 Temperature sensor
- 2 Cable tie



Installing temperature sensor

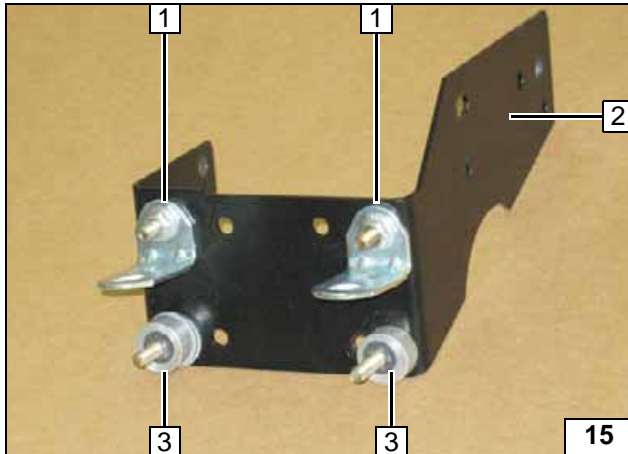
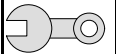

Preparing installation location

- 1 M6x20 bolt, angle bracket, flanged nut [2x each]
- 2 Bracket
- 3 M6x35 bolt, spring lockwasher, large diameter washer [2x], 10 mm shim, pin lock [2x each]

Preparing bracket

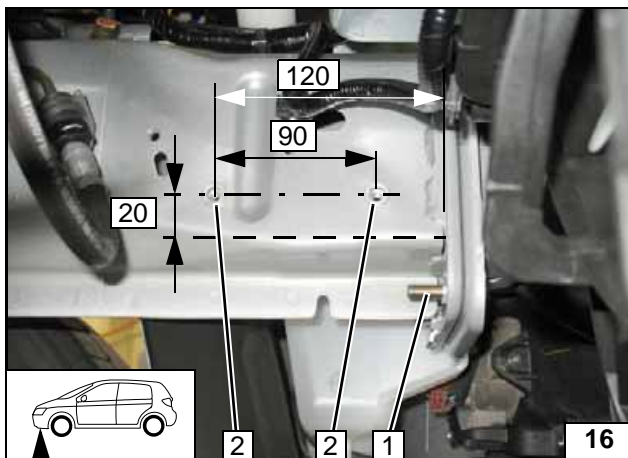

Replace original vehicle bolt with M8 bolt and large diameter washer at Position 1.

- 2 Drill 9.1 mm dia. hole; install rivet nut [2x each]



Installing rivet nut

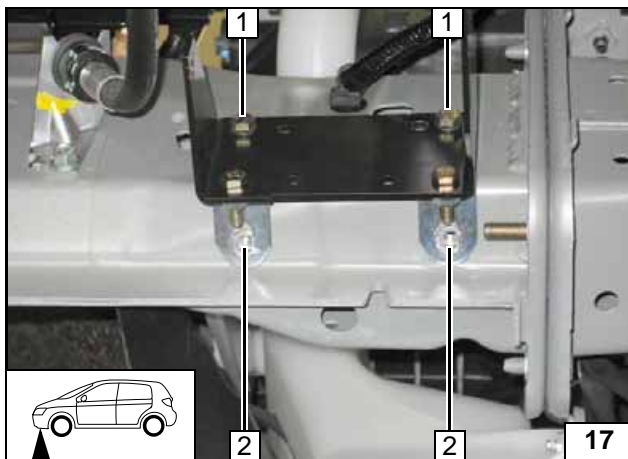

Loosely mount bracket with premounted M6x35 bolts 1 [2x] on rivet nuts.

- 2 Copy hole pattern [2x]



Copying hole pattern

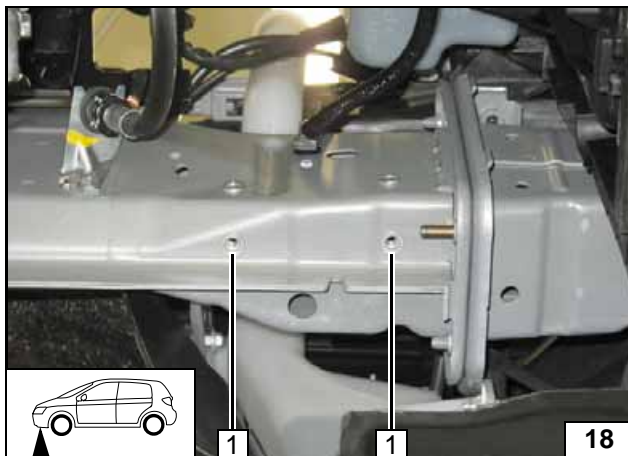

Remove bracket.

- 2 Drill 9.1 mm dia. hole; install rivet nut [2x each]



Installing rivet nut

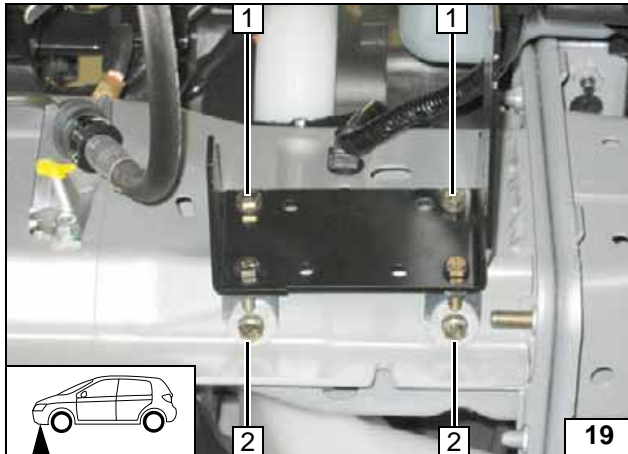
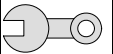

Mount bracket with premounted M6x35 bolts 1 [2x] on rivet nuts.

2 M6x20 bolt, spring lockwasher, large diameter washer [2x each] on rivet nuts



Installing bracket

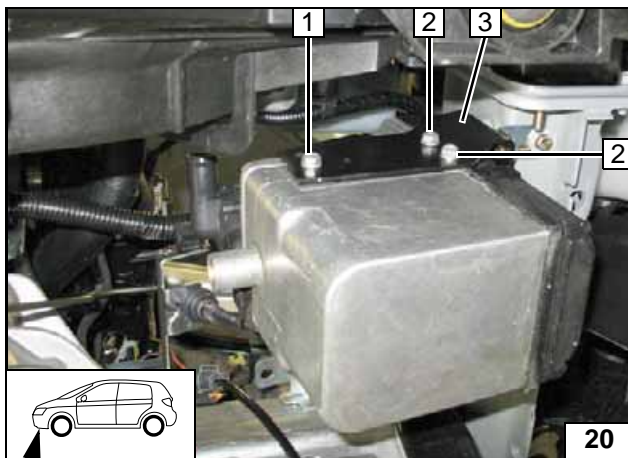

Installing heater

Insert two washers between heater and bracket 3 at Position 1.

1 E-jot screw, washer [2x]
2 E-jot screw [2x]



Installing heater

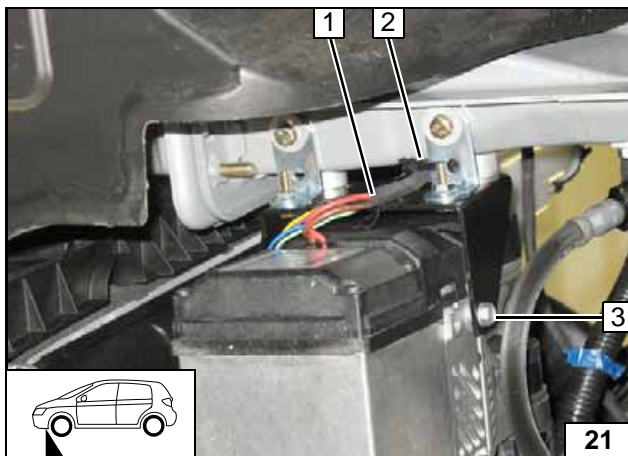

1 Wiring harness of heater
2 Cable tie
3 E-jot screw

Installing heater

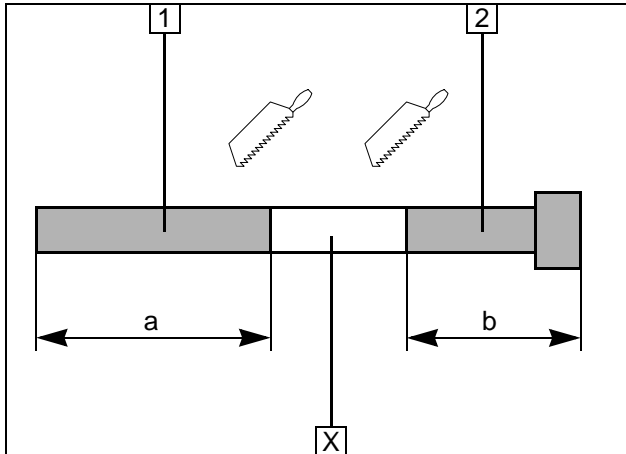
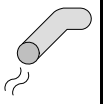

Exhaust gas

- 1 Exhaust pipe
a = 300
- 2 Exhaust end section
b = 170

Discard section X

Preparing exhaust pipe

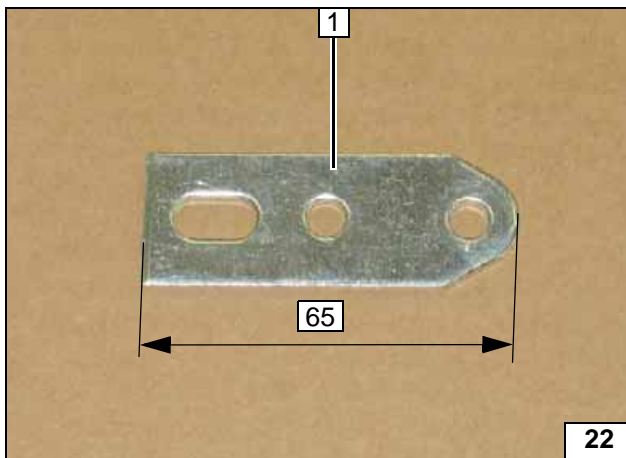

- 1 Cut perforated bracket to length

Preparing perforated bracket

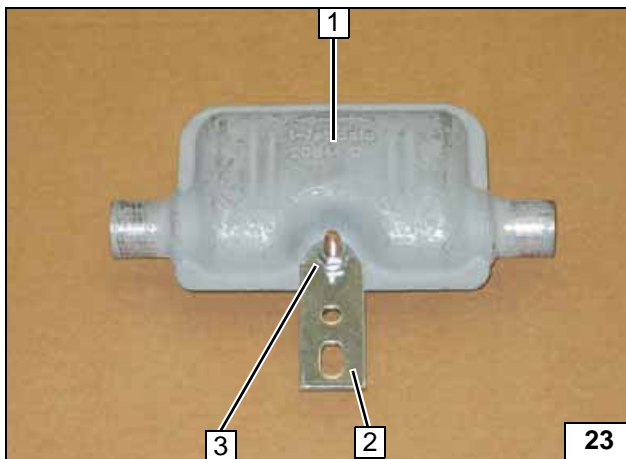

- 1 Muffler
- 2 Perforated bracket
- 3 M6x20 bolt, flanged nut

Preassembling muffler

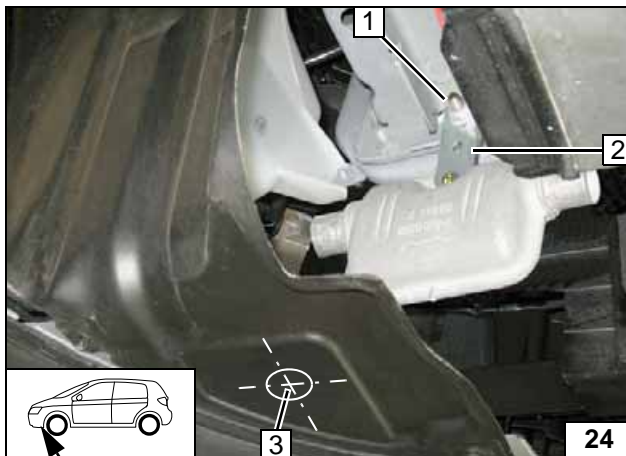

42 mm dia. hole at Position 3 in wheel well trim.

- 1 M8 flanged nut on prepared M8x30 bolt
- 2 Perforated bracket



Installing muffler

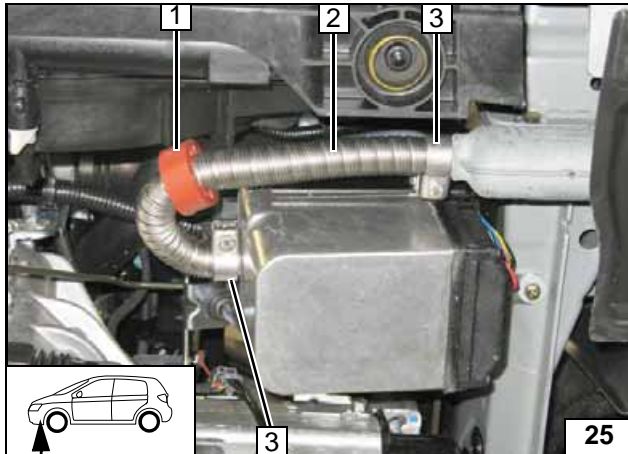

- 1 Red (rt) rubber isolator
- 2 Exhaust pipe
- 3 Hose clamp [2x]

Installing exhaust pipe

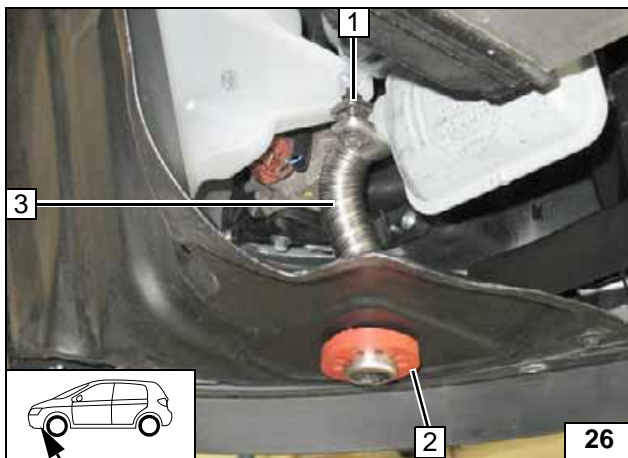

- 1 Hose clamp
- 2 Red (rt) rubber isolator with groove
- 3 Exhaust end section

Installing exhaust end section

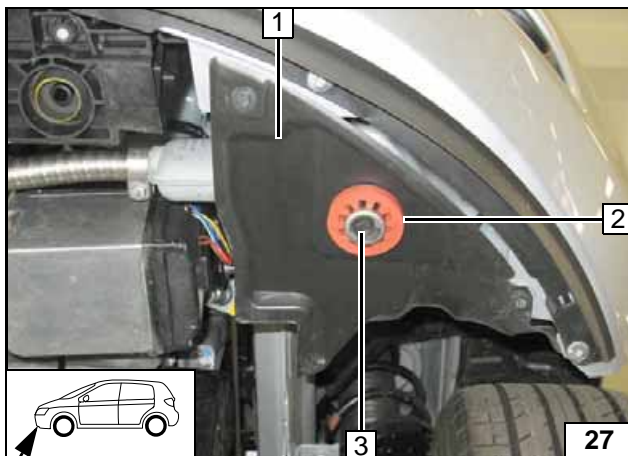

Align exhaust end section 3 flush on red rubber isolator 2.

- 1 Wheel well trim



Mounting rubber isolator



Fuel

CAUTION!

Open the vehicle's fuel tank cap, ventilate the tank and then re-close the tank lock.

Catch any fuel running off with an appropriate container.

Install fuel line and metering-pump wiring harness so that they are protected against stone impact. Unless specified otherwise, always fasten using cable ties. Mount the fuel line and wiring harness with rub protection on sharp edges.

WARNING!

The fuel line and wiring harness are routed to the metering pump in as shown in the wiring harness routing diagram.

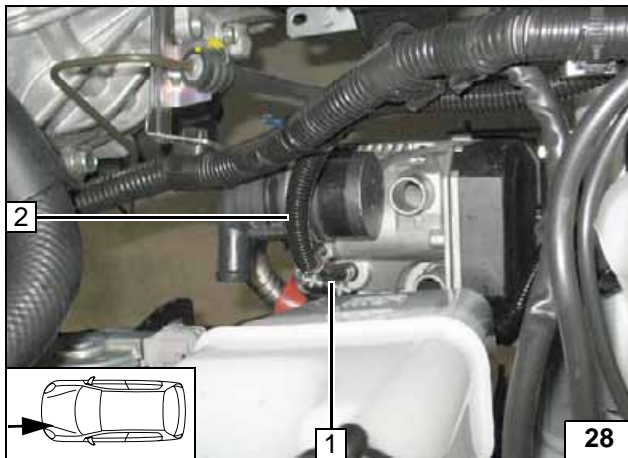

- 1 Hose section, 10 mm dia. clamp [2x]
- 2 Fuel line in corrugated tube

Connect-
ing heater



Fuel line and wiring harness of metering pump 1 in corrugated tube



Installing
lines

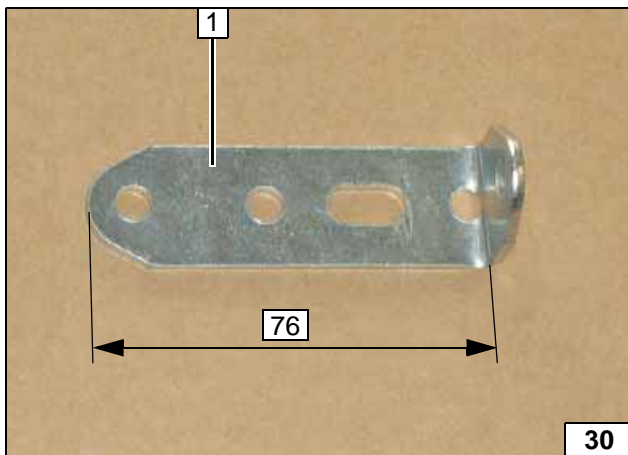

Bend perforated bracket 1 by 90°.

Preparing
perforated
bracket

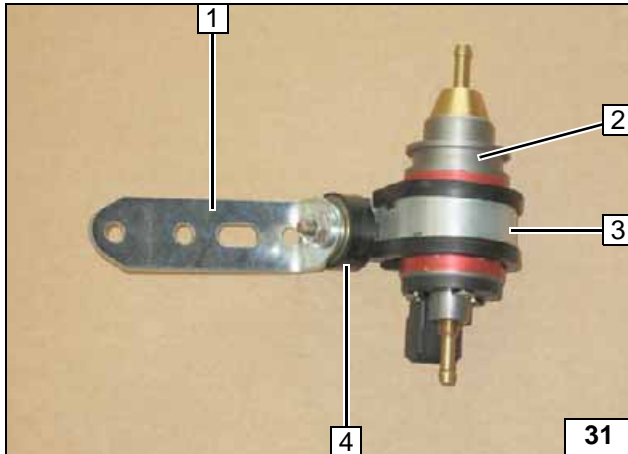

- 1 Perforated bracket
- 2 Metering pump
- 3 Rubber-coated pipe clamp
- 4 Silent block, flanged nut [2x]

Preparing metering pump

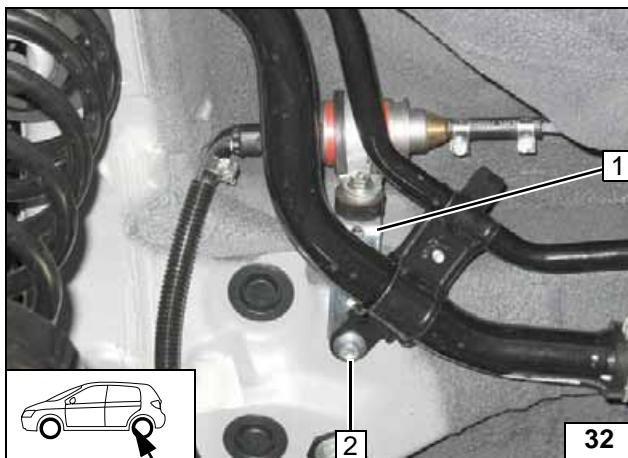

- 1 Perforated bracket
- 2 Original vehicle bolt



Installing metering pump

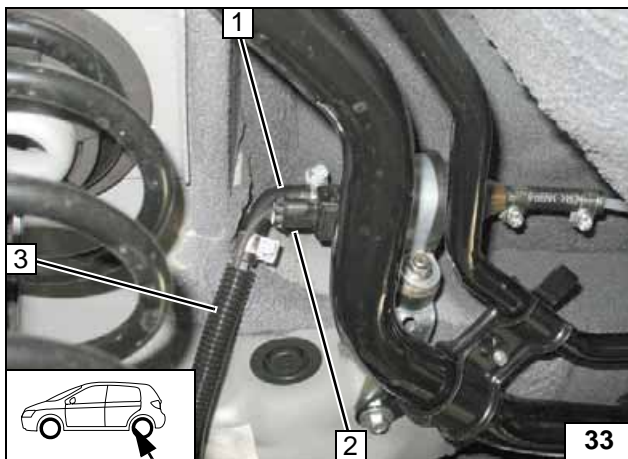

- 1 90° moulded hose, 10 mm dia. clamp [2x]
- 2 Wiring harness of metering pump, connector mounted
- 3 Fuel line in corrugated tube

Connecting metering pump

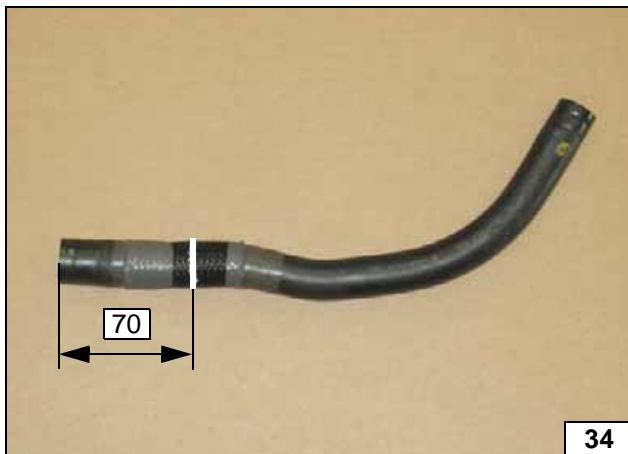

Remove fuel-tank vent line and braided protection and separate at marking.



Removing fuel

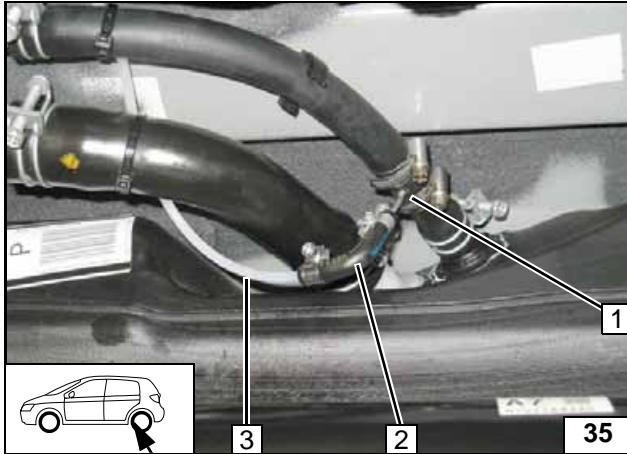
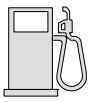

Install hose section of fuel-tank vent line. Shape fuel standpipe 1 according to template and cut to length. Align removal pipe of fuel standpipe to fuel tank bottom.

- 1 Fuel standpipe, 24-27 mm dia. clamp [2x]
- 2 90° moulded hose, 10 mm dia. clamp [2x]
- 3 Fuel line



Installing fuel standpipe

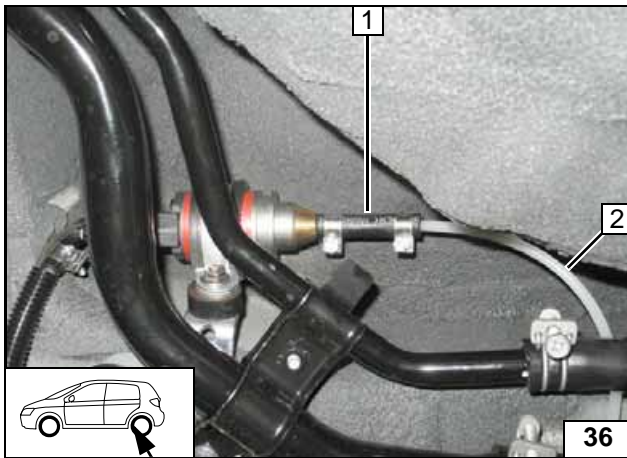

Check the position of the components; adjust if necessary. Check that they have free clearance.

- 1 Hose section, 10 mm dia. clamp [2x]
- 2 Fuel line



Connecting metering pump

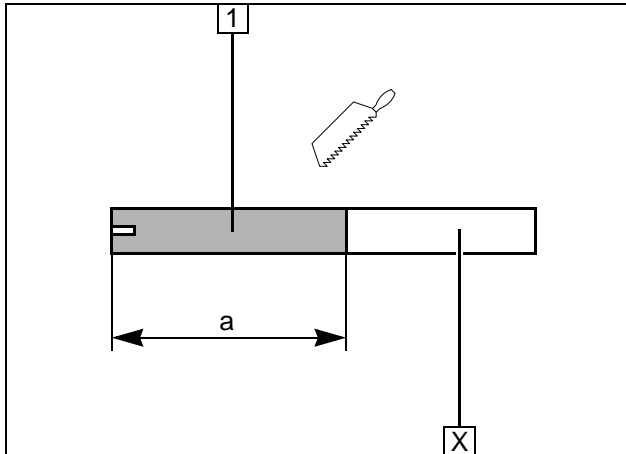
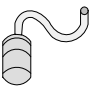

Combustion air

- 1 Combustion air pipe
a = 300

Discard section X

Cutting combustion air pipe to length

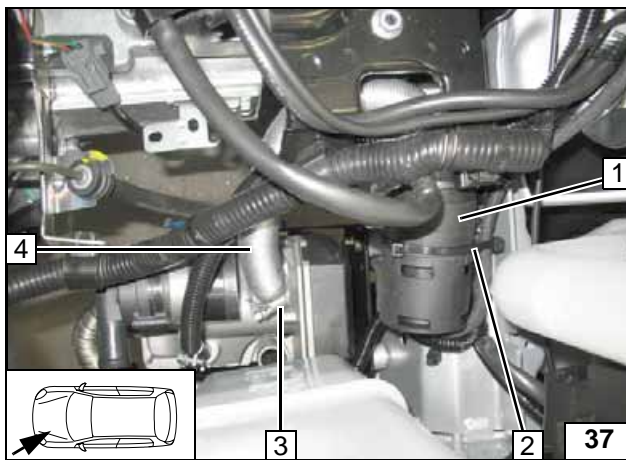

- 1 Muffler
- 2 Cable tie
- 3 27 mm dia. clamp
- 4 Combustion air pipe



Installing muffler

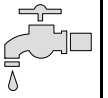

Coolant circuit

CAUTION!

Any coolant running off should be collected using an appropriate container! Route hoses kink-free! Unless specified otherwise, always fasten using cable ties. Position clamps so that no other hose can be damaged! When installing the hoses, the heater must be filled with coolant. The connection should be "inline" based on the following diagram:

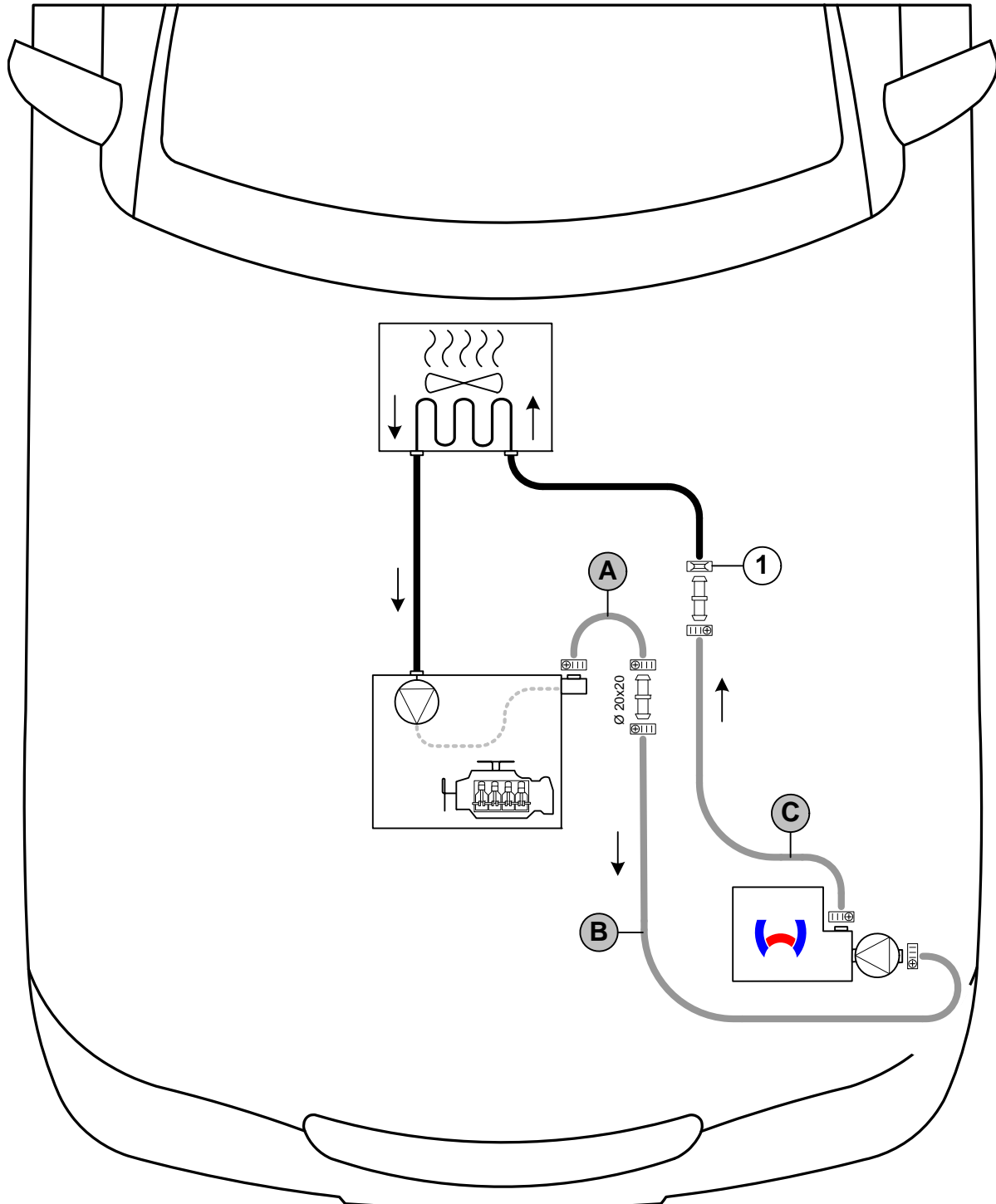

Hose routing diagram

Undesignated connecting pipe  = 18x20 mm dia.

All hose clamps  = 20-27 mm dia.

1 = Original vehicle spring clip .



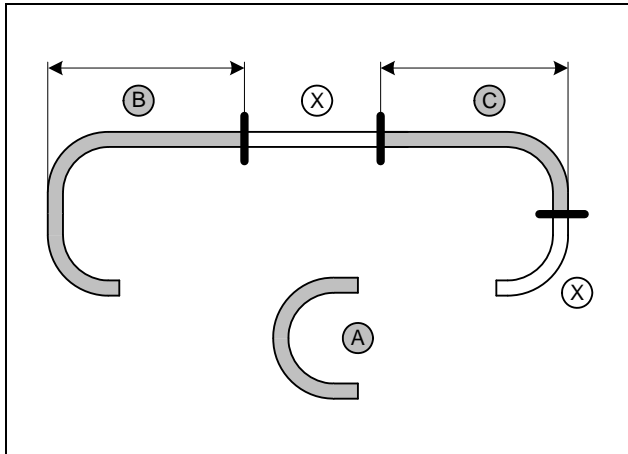
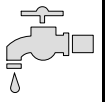

Hose **A** = 180° elbow
Discard section **X**.

B = 440
C = 550



Cutting hoses to length

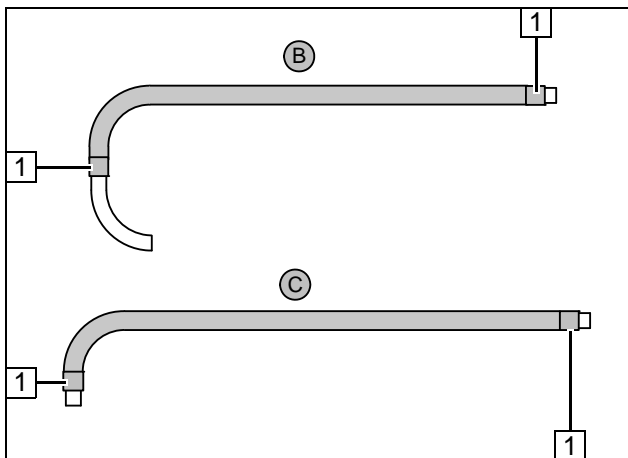

Cut braided protection hose in centre and slide onto hose **B** and **C**.
Cut heat shrink plastic tubing to length.

1 25 mm long heat shrink plastic tubing [4x]



Preparing hoses

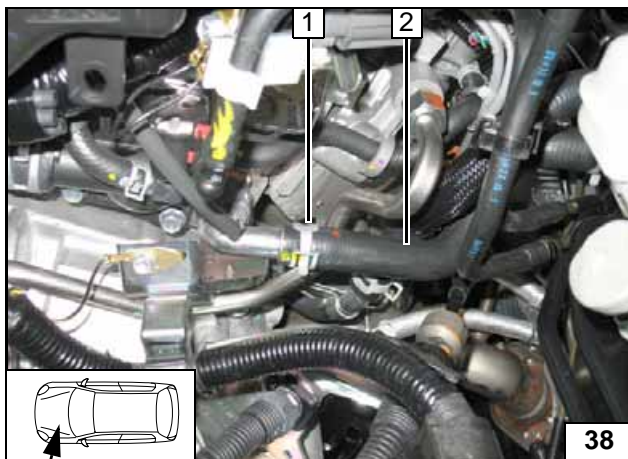

Disconnect hose to engine outlet/heat exchanger inlet **2** at connection piece of engine outlet. Spring clip **1** will be reused.



Cutting point

1 Cable tie

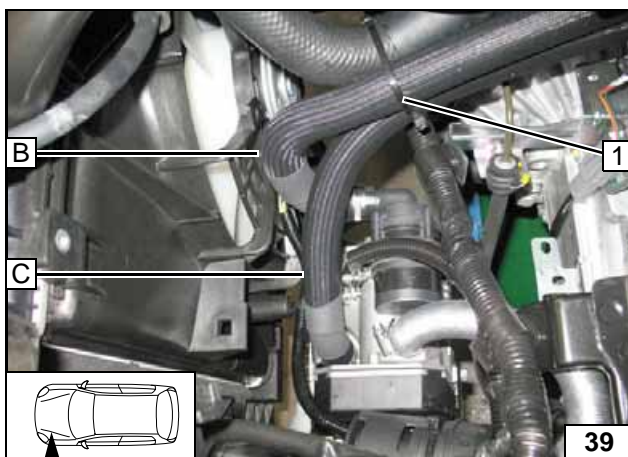

Connecting heater

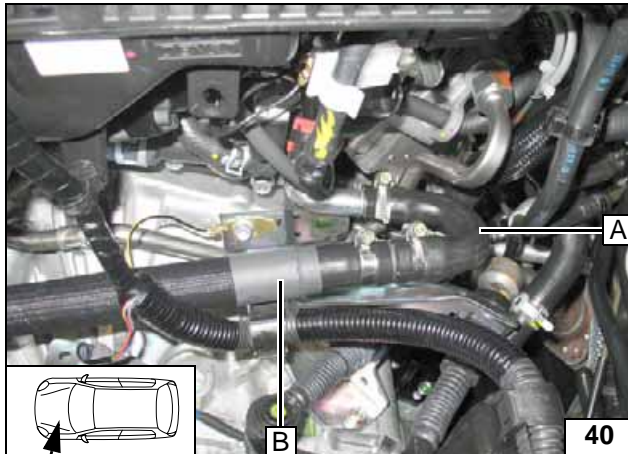

Connect-
ing engine
outlet

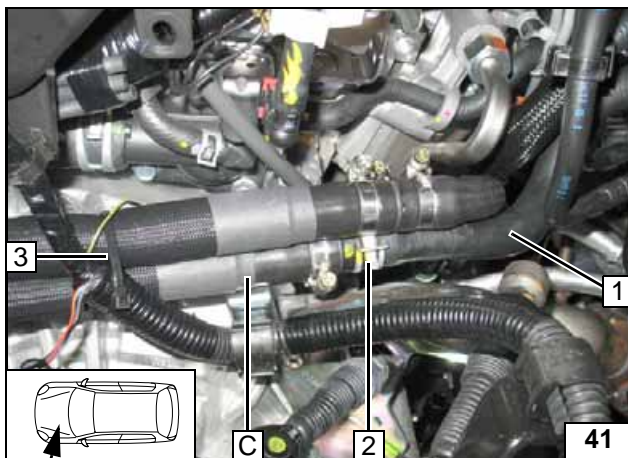

- 1 Hose on heat exchanger inlet
- 2 Original vehicle spring clip
- 3 Cable tie

Connect-
ing heat
exchanger
inlet

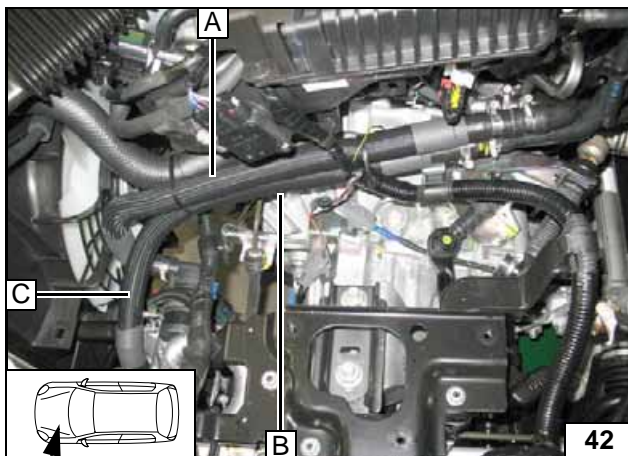

Ensure sufficient distance to neighbouring components.



Aligning
hoses

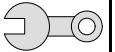

Final Work

WARNING!

Mount removed parts in reverse order. Check all hoses, clamps and all electrical connections for firm seating. Insulate and tie back all loose wires.

Only use manufacturer-approved coolant. Spray heater components with anti-corrosion wax (Tectyl 100K, Order No. 111329).

- **Connect the battery.**
- **Fill and bleed the coolant circuit according to the vehicle manufacturer's specifications.**
- **Adjust digital timer, learn telestart remote option**
- **Make settings on A/C control panel according to the "Operating Instructions for End Customer".**
- **Place the instruction label "Switch off parking heater before re-fuelling" in the area of the filling necks**
- **For initial startup and function test, see installation instructions**



Webasto AG
Postfach 80
D-82132 Stockdorf / Germany
National Hotline: 01805 93 22 78
(14 Cent aus dem deutschen Festnetz)
Hotfax: 0395 5592 353
Hotmail: hotline@webasto.de
<http://www.webasto.de>

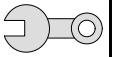

Template for Fuel Standpipe

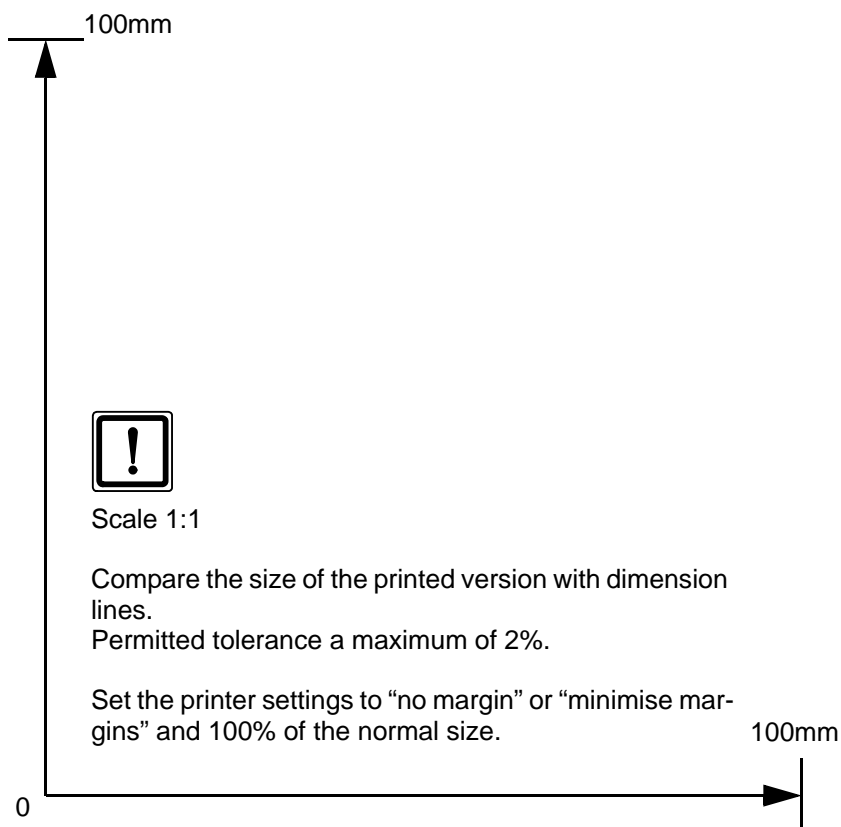
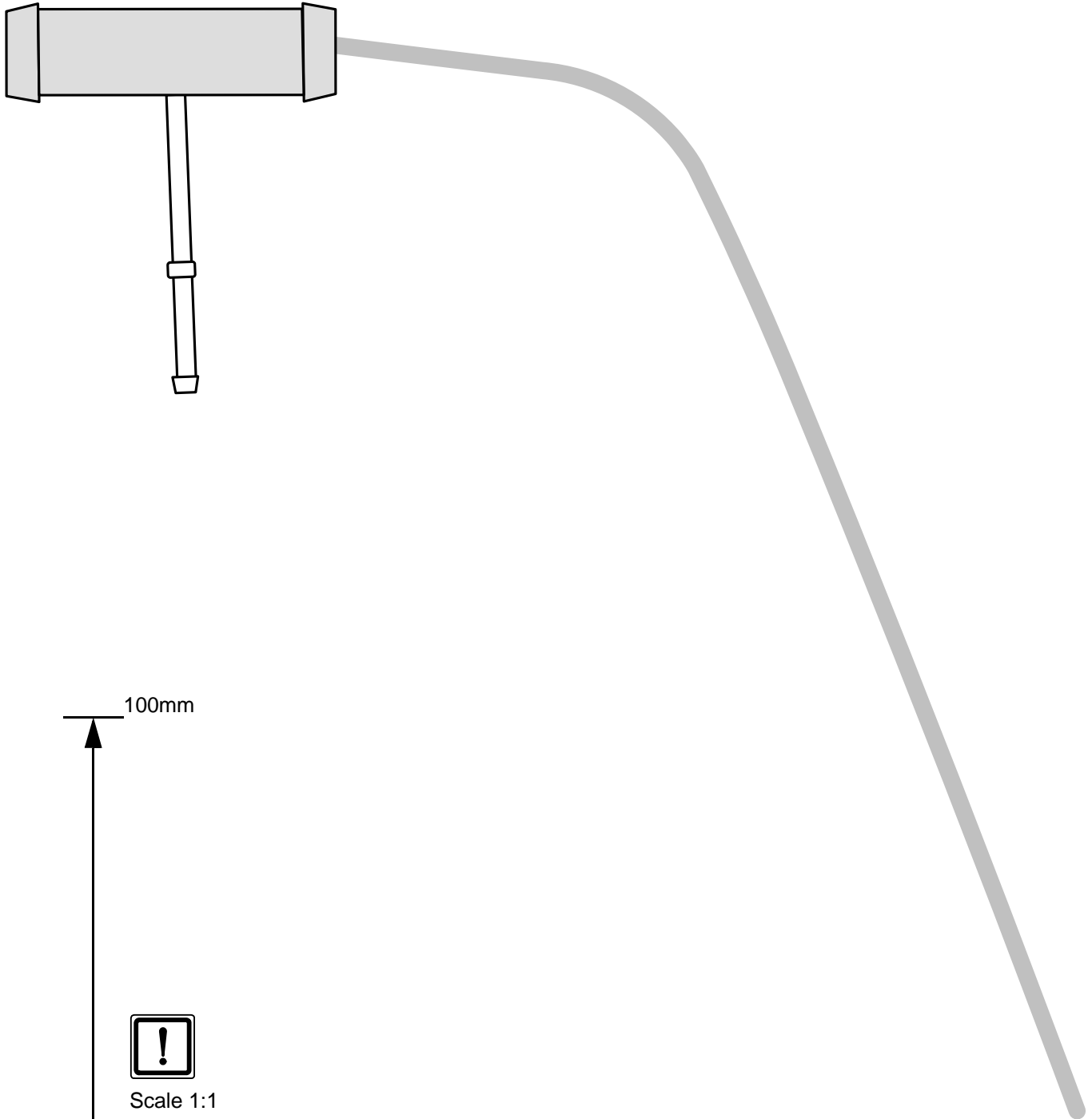

Scale 1:1

Compare the size of the printed version with dimension lines.
Permitted tolerance a maximum of 2%.

Set the printer settings to "no margin" or "minimise margins" and 100% of the normal size.

Operating Instructions for End Customer



Please remove page and add to the vehicle operating instructions.



Note:

We recommend matching the heating time to the driving time.

Heating time = driving time

Example:

For a driving time of approx. 20 min. (in one direction), we recommend not exceeding a switch-on time of 20 min.

If the summer/winter switch option has been installed, this must be switched in accordance with the time of year. The heater will then only switch on the vehicle fan to ventilate the vehicle interior in the position Winter  heat and in the position Summer .



Before parking the vehicle, make the following settings:

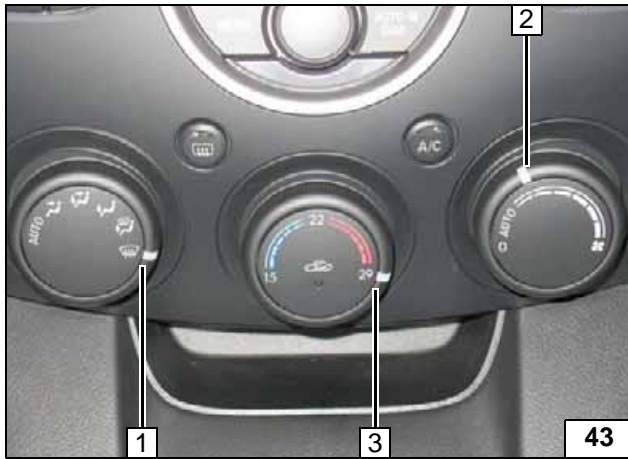

- 1 Air outlet to windshield
- 2 Set fan to level "1", or possibly "2"
- 3 Set temperature to "max."

**Automatic
air-conditioning**

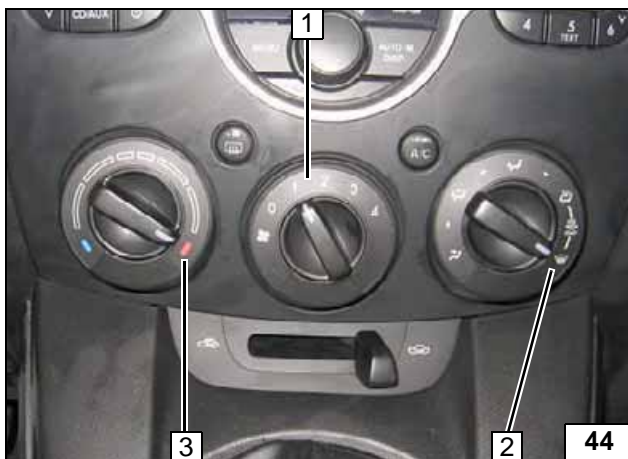

- 1 Set fan to level "1", or possibly "2"
- 2 Air outlet to windshield
- 3 Set temperature to "max."

**Manual air
conditioning**