

Water Heater



Thermo Top E Parking Heater

e1
00 0003

Thermo Top C Parking Heater

e1
00 0002

Thermo Top P Parking Heater

e1
00 0104

Installation documentation

Citroen C4 Picasso

Gasoline

from Model Year 2006

Left-hand drive vehicle

Electr. 6-gear transmission (EGS6)



WARNING!

Hazard warning:

Incorrect installation or repair of Webasto heating systems may cause a fire or result in the emission of carbon monoxide, which can be fatal. Serious or fatal injuries can be caused as a result.



Specialist company training, technical documentation, specialised tools and equipment are required to install and repair Webasto heating and cooling systems. Only original Webasto parts must be used. For this, also see the catalog of air and water heater accessories from Webasto.

NEVER attempt to install or repair Webasto heating or cooling systems if you have not successfully completed the company training and thereby acquired the required technical skills, or if you do not have access to the required technical documentation, tools and equipment needed to carry out correct installation and repairs.

ALWAYS follow all Webasto installation and repair instructions and observe all warnings.

Webasto does not accept any liability for defects and damage that are attributable to installation by untrained staff.

Table of Contents

Validity	2	Preparing heater	16
Heater/Installation Kit	3	Preparing installation location	17
Foreword	3	Installing heater	19
General Instructions	3	Coolant circuit	20
Special Tools	3	Fuel	24
Explanatory Notes on Document	4	Combustion air	27
Preliminary Work	5	Exhaust gas	28
Heater installation location	5	Final Work	29
Preparing electrical system	6	Template for Fuel Standpipe	30
Electrical system	7	Operating Instructions for End Customer	31
Fan controller for manual air conditioning	8		
Automatic air-conditioning fan controller	11		
Digital timer, optional Summer/winter switch option	15		
Remote option (Telestart)	15		

Validity

Manufacturer	Model	Type	EG-BE No./ABE
Citroen	C4 Picasso	U	e2 * 2001 / 116 * 0345 * ...

Engine type	Engine model	Output in kW	Displacement in cm ³
6FY	Gasoline	92	1749

Vehicle and engine types, equipment variants and national specifications not listed in these installation instructions have not been tested. However, installation according to these installation instructions may be possible.

The installation location of a digital timer and summer/winter switch should be confirmed with the end customer before installation.

Heater/Installation Kit

Quantity	Description	Order No.:
1	Retail accessories <i>Thermo Top E / C / P</i>	See price list
1	Installation Kit for Citroen C4 Picasso 2006 Gasoline EGS6	1311819E
1	Heater control	See price list

Heater recommended for the respective vehicle class:

Vehicle	Heater
Compact car	Thermo Top E
Mid-size car, station wagon	Thermo Top C
Full-size car, van, offroader	Thermo Top P

The selection of the heater is based on the passenger compartment size of the vehicle and the level of comfort required by the customer!



Foreword

These installation instructions apply to the vehicles Citroen C4 Picasso Gasoline - for validity, see page 2 - from model year 2006 and later, assuming technical modifications to the vehicle do not affect installation, any liability claims excluded. Depending on the vehicle version and equipment, modifications may be necessary during installation with respect to these installation instructions.

However, the stipulations in the "installation instructions" and "operating and maintenance instructions" for the *Thermo Top C/P/E* must always be observed.

The corresponding rules of technology and any information from the vehicle manufacturer should be observed during the installation work.

General Instructions

Installation should be carried out according to the general, standard rules of technology. Unless specified otherwise, fasten hoses, lines and wiring harnesses to original vehicle lines and wiring harnesses using cable ties.

Sharp edges must be provided with rub protection (cut-open fuel hose)!

Spray unfinished body areas, e.g. drilled holes, with anti-corrosion wax (Tectyl 100K, Order No. 111329). When using an IPCU, the settings specified in this document must be checked on the vehicle and adjusted if necessary, before installation.

Special Tools

- Torque wrench for 2.0 - 10 Nm
- Hose clamping pliers
- Metric thread-setter kit

Explanatory Notes on Document

To provide you with a quick overview of the individual working steps, you will find an identification mark on the outside top right corner of the page in question.

Mechanical system

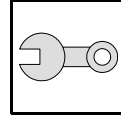

Electrical system

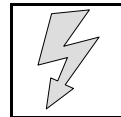

Coolant circuit

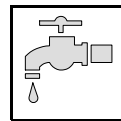

Fuel

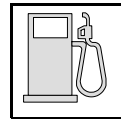

Exhaust gas

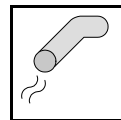

Combustion air

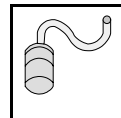

Special features are highlighted using the following symbols:



Specific risk of injury or fatal accidents.



Specific risk of damage to components.



Specific risk of fire or explosion.



Reference to general installation instructions of Webasto components or to the manufacturer's vehicle-specific documents.



Reference to a special technical feature.

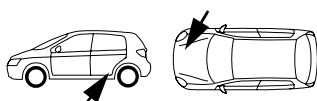

The arrow in the vehicle icon indicates the position on the vehicle and the viewing angle.

All dimensions are in mm!

Tightening torque of hose clamps = 2.0 + 0.5 Nm!

Tightening torque of Ejet screws, Ejet studs = 10 Nm!

Preliminary Work

WARNING!

- Disconnect the battery "earth" or "ground" connection.
- Depressurize the cooling system.
- Copy the factory number from the original type label to the duplicate type label.
- Remove years that do not apply from the duplicate label.
- Attach the duplicate label (type label) in the appropriate place.
- Open the fuel tank cap and vent the fuel tank.
- Close the tank cap again.
- Remove the engine cover (depending on the vehicle equipment, if installed)
- Remove the air cleaner box with the intake hose and resonator (depending on the vehicle equipment, if installed)
- Completely remove the battery and the battery carrier.
- Remove the exhaust system.
- Remove the fuel tank according to the manufacturer's specifications.
- Remove the bumper.
- Remove the underride protection
- Remove the lower instrument panel trim on the driver's and front passenger side
- Remove the glove compartment.

Remove page 31 "Operating Instructions for End Customer" and add to the vehicle operating instructions.

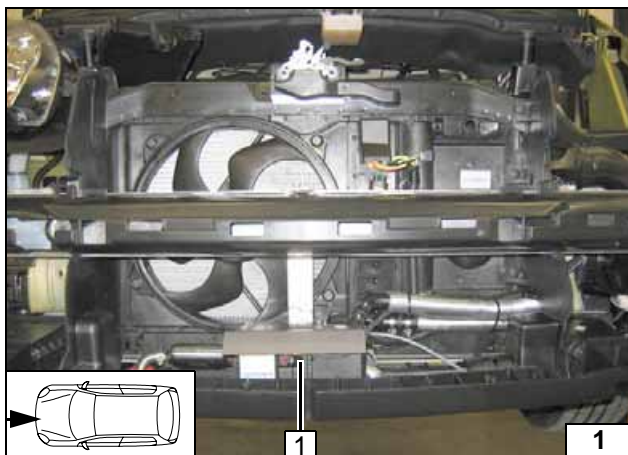

Heater installation location

1 Heater

Installation location

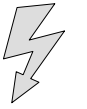

Preparing electrical system

Wires **6** to **9** only with automatic air-conditioning

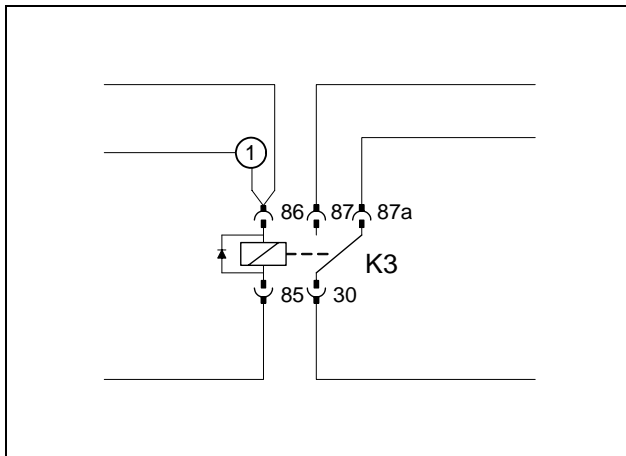
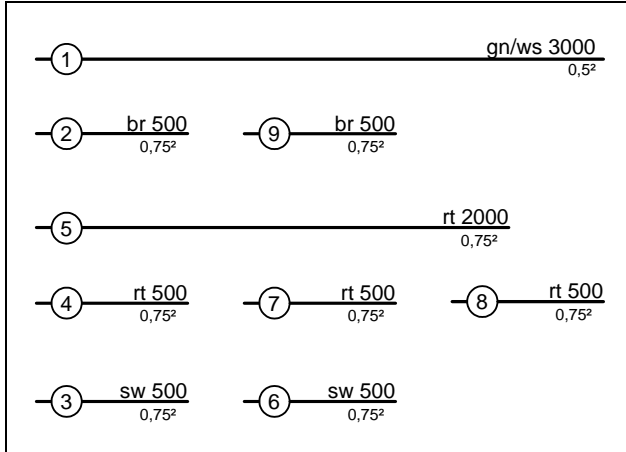

Produce connections as shown in wiring diagram. Pull wire section **1** into protective sleeving provided and route together with wiring harness of digital timer and fan controller into passenger compartment.

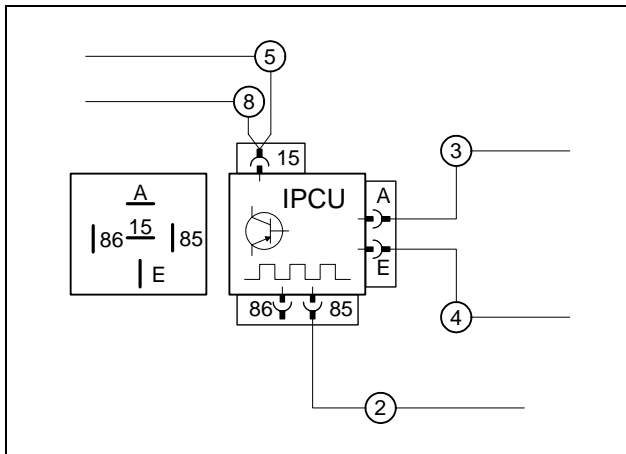

Connect wires to IPCU (IPCU view on contact side). Pull wire **5** into the protective sleeving provided and route to OBD socket outlet. Wire **8** only with automatic air-conditioning. The IPCU is pre-programmed with the following settings:

Duty cycle: 46% Frequency: 400 Hz
Voltage: 10 V Function: Low-side

The fan level corresponding to 2 - 3 on the vehicle and the current intake of the fan motor is to be checked in the function control; correct the settings if necessary

Automatic air-conditioning

Produce connections as shown in wiring diagram.

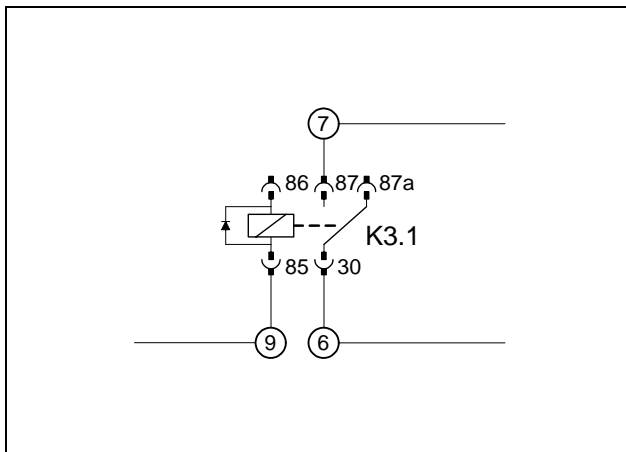

Cutting wires to length

Preparing K3 relay

Preassembling IPCU

Preparing additional relay K3.1



Electrical system

Positive wire

Before installing, crimp 8 mm dia. cable lug onto positive wire.

- 1 Red (rt) wire
- 2 Original vehicle positive support point

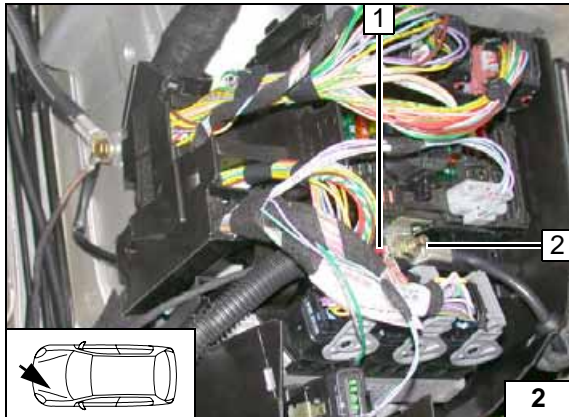

Wiring harness pass through

Route wiring harnesses (digital timer, fan controller and green/white (gn/ws wire in protective sleeving) on original vehicle wiring harness 1 to protective rubber plug 2 and route into passenger compartment.

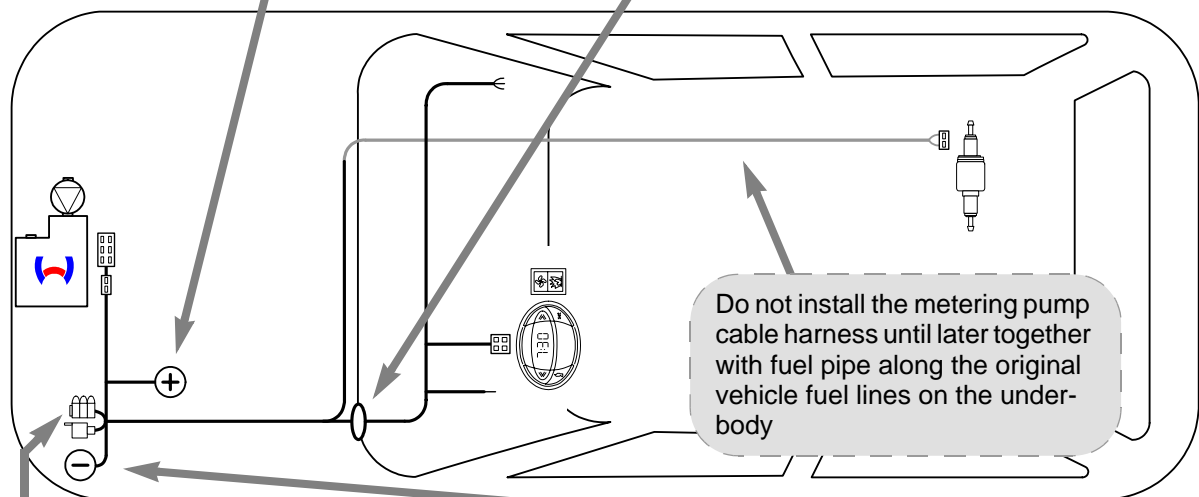
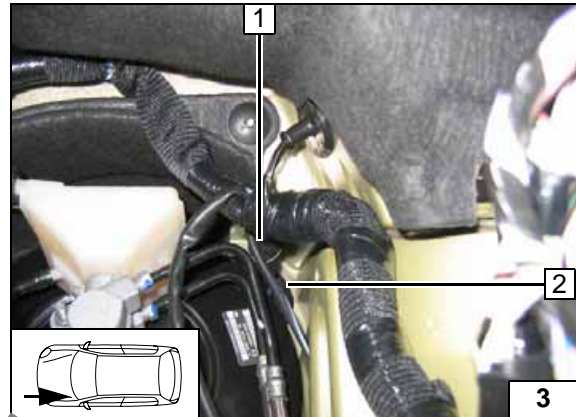

Wiring harness installation diagram

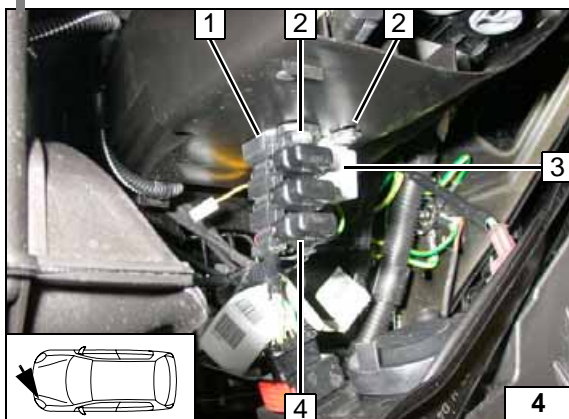

Fuse holder, K3 relay

- 1 Retaining plate for fuse holder
- 2 4 mm dia. hole, 5.5x13 self-tapping screw; plastic nut [2x each]
- 3 K3 relay
- 4 Fuse holder

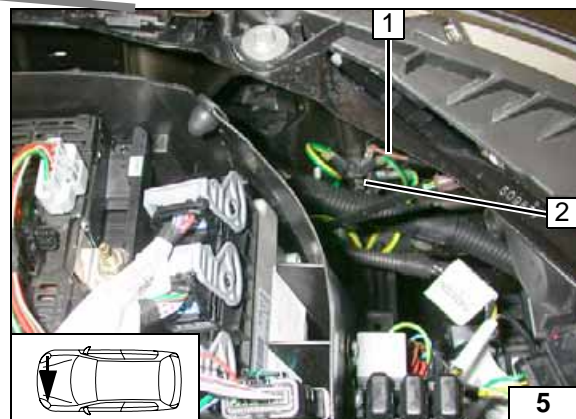

Ground wire

- 1 Brown (br) wire
- 2 Original vehicle ground support point



Fan controller for manual air conditioning

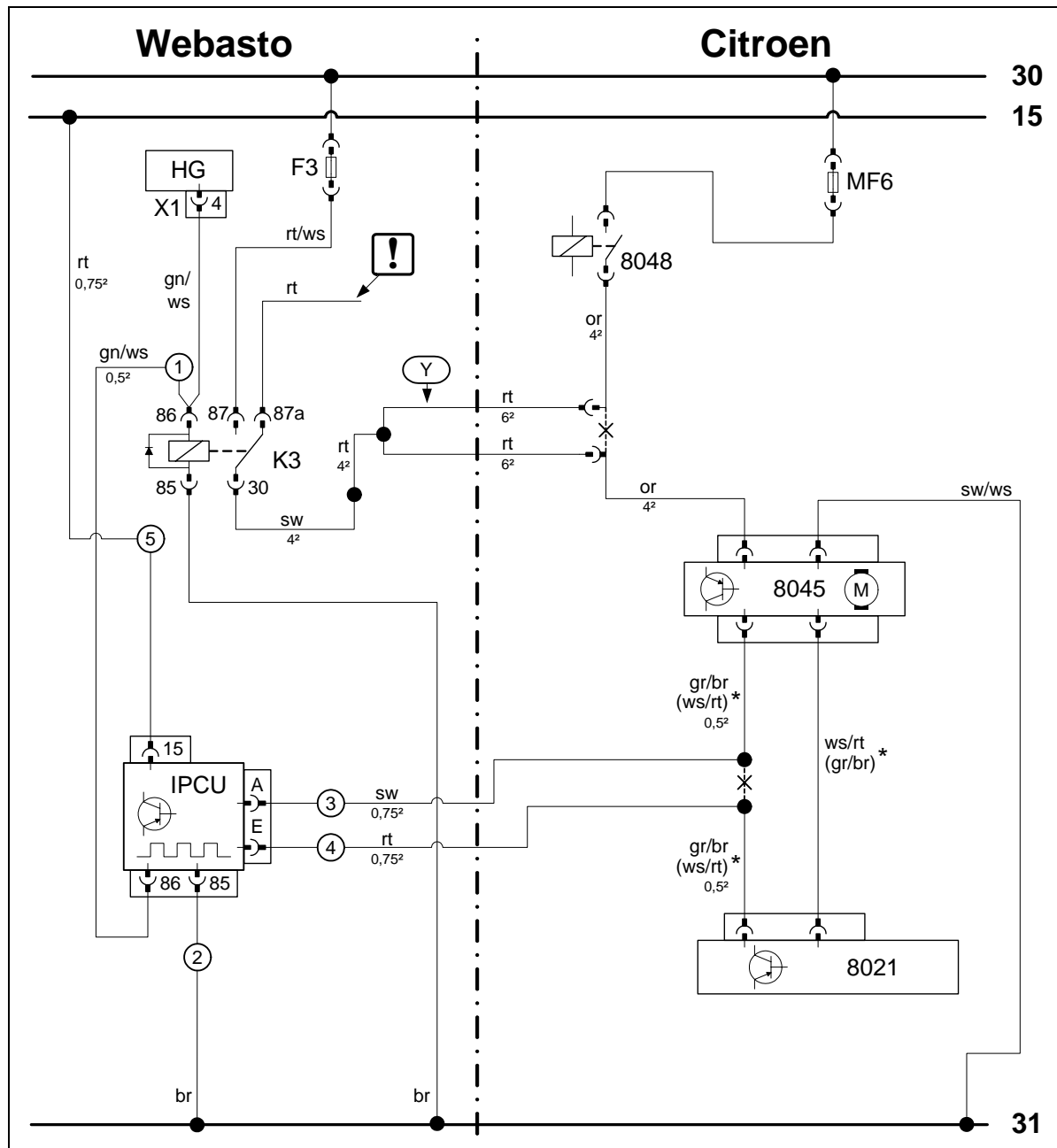

Wiring diagram

Webasto components		Vehicle components		Colours and symbols	
HG	TT-C/E/P heater	8021	Air-conditioning control unit	rt	red
X1	6-pin heater connector	8045	Fan module	ws	white
F3	25 A fuse	8048	Fan relay	sw	black
K3	Fan relay	MF6	Fuse	br	brown
IPCU	Pulse width modulator			gn	green
Y	Wiring adapter			bl	blue
				or	orange
				gr	gray
		*	The values specified in brackets are valid from Model Year 2010!	!	Press out wire end, insulate and tie back
				X	Cutting point
				Wiring colours may vary.	

Legends

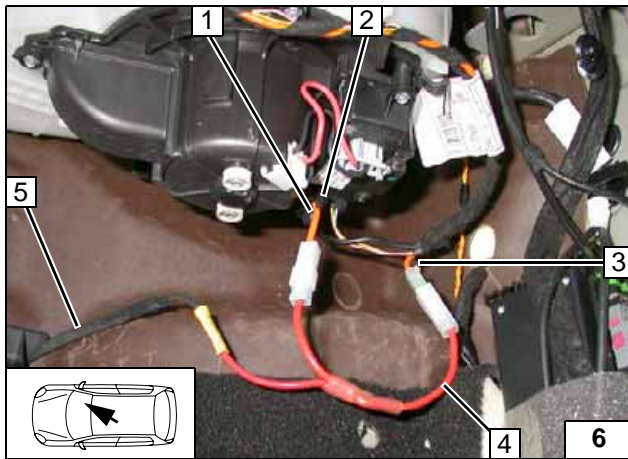
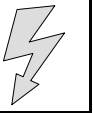

Produce connections as shown in wiring diagram.
The control takes place on connector 2 from fan module - connector, depending on the vehicle

- 1 wire or connector of fan controller
- 3 Wire or fan relay
- 4 Y-adapter
- 5 Black (sw) wire from K3/30



Connection to fan module

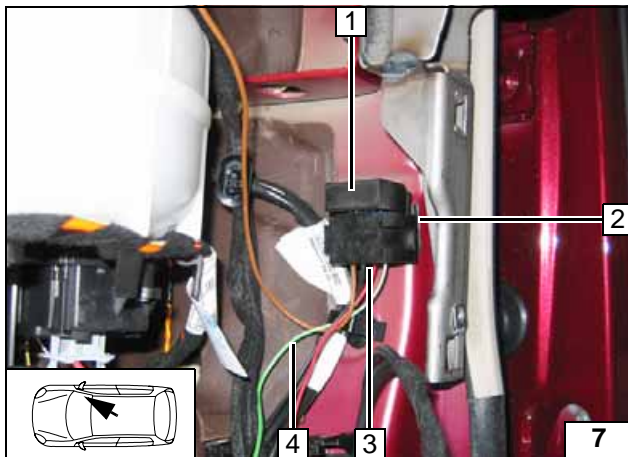

Before installing, connect green/white (gn/ws) wire 4 from K3/86 to base of IPCU 3 terminal 86.

- 1 IPCU
- 2 Double-sided adhesive tape



Installing base from IPCU

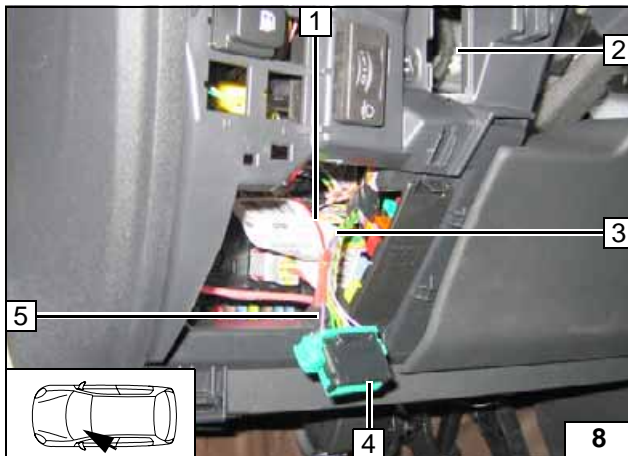

Control changeover of IPCU is carried out on 16-pin OBD socket outlet 4.
Produce connections as shown in wiring diagram.

- 1 Red (rt) wire IPCU/15
- 2 Socket of OBD socket outlet
- 3 Pink (pk) wire (terminal 15)
- 5 Pink (pk) wire of OBD socket outlet, Pin 1

Power supply of IPCU

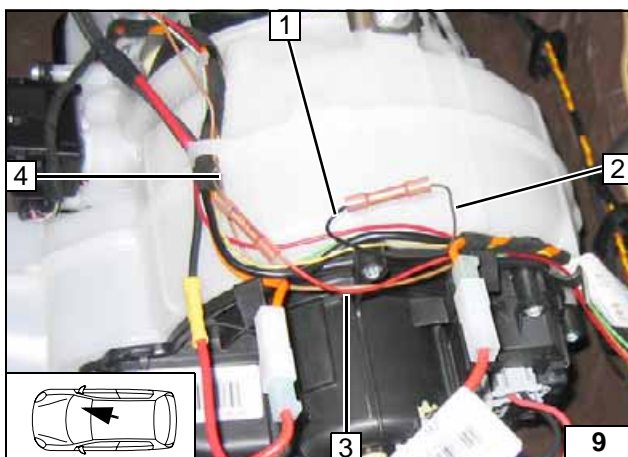

Model year up to 2009

Produce connections as shown in wiring diagram.
The control takes place before the fan controller connector.

- 1 Black (sw) wire of IPCU/A
- 2 Green/brown (gr/br) wire or connector of fan controller
- 3 Red (rt) wire of IPCU/E
- 4 Green/brown (gr/br) wire of connector of A/C control panel



Connecting fan controller

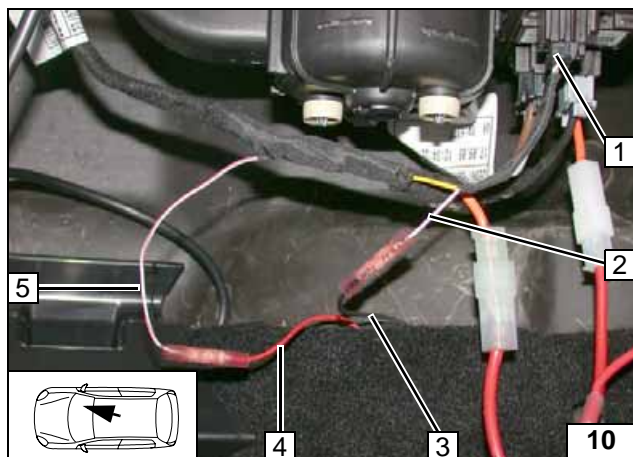

Model year from 2010

Produce connections as shown in wiring diagram.
The control takes place at connector 1 from fan controller.

- 2 White-red (ws/rt) wire of fan motor connector
- 3 Black (sw) wire of IPCU/A
- 4 Red (rt) wire of IPCU/E
- 5 White-red (ws/rt) wire of A/C control panel



**Connect-
ing fan
controller**



Automatic air-conditioning fan controller

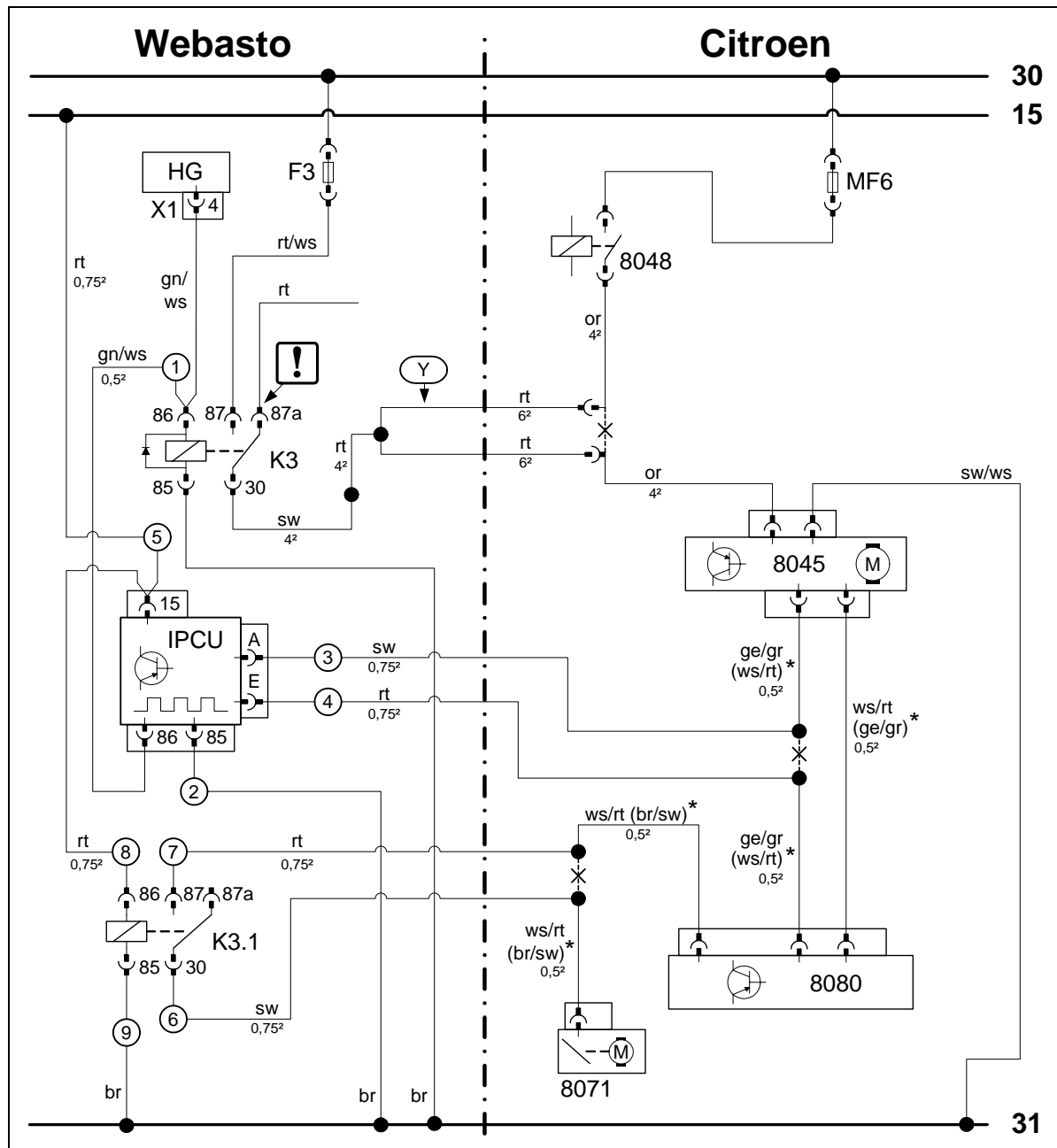

Wiring diagram

Webasto components		Vehicle components		Colours and symbols	
HG	TT-C/E/P heater	8080	Air-conditioning control unit	rt	red
X1	6-pin heater connector	8071	Air distribution	ws	white
F3	25 A fuse	8048	Fan relay	sw	black
K3	Fan relay	8045	Fan module	br	brown
IPCU	Pulse width modulator	MF6	Fuse	gn	green
Y	Wiring adapter			bl	blue
K3.1	Additional relay			ge	yellow
				gr	gray
				or	orange
		*	The values specified in brackets are valid from Model Year 2010!	!	Press out wire end, insulate and tie back
				X	Cutting point
					Wiring colours may vary.

Legends

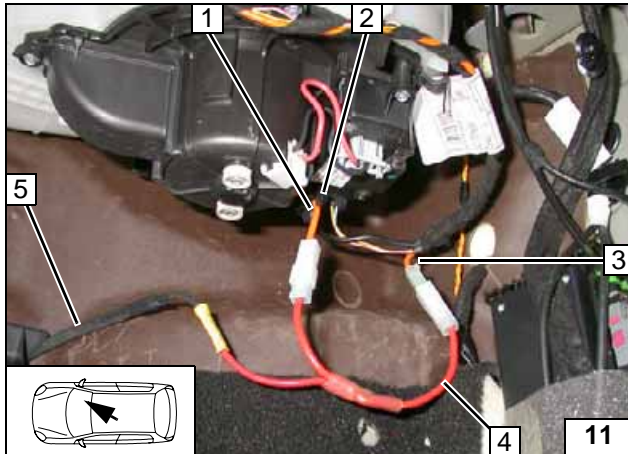

Model year up to 2009

Produce connections as shown in wiring diagram. The control takes place at connector 2 from fan controller.

- 1 wire or connector of fan controller
- 3 Wire or fan relay
- 4 Y-adapter
- 5 Black (sw) wire from K3/30



**Connec-
tion to fan
module**

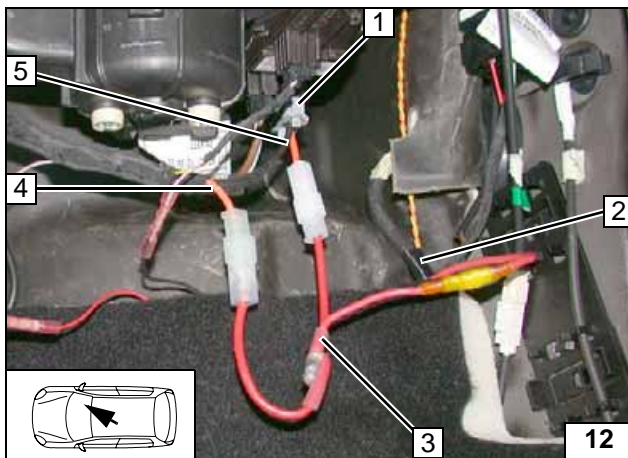

Model year from 2010

The fan motor is controlled on connector 1 from fan controller. Produce connections as shown in wiring diagram.

- 2 Black (sw) wire from K3/30
- 3 Y-adapter
- 4 Wire or fan relay
- 5 wire or connector of fan controller



**Connec-
tion to fan
controller**

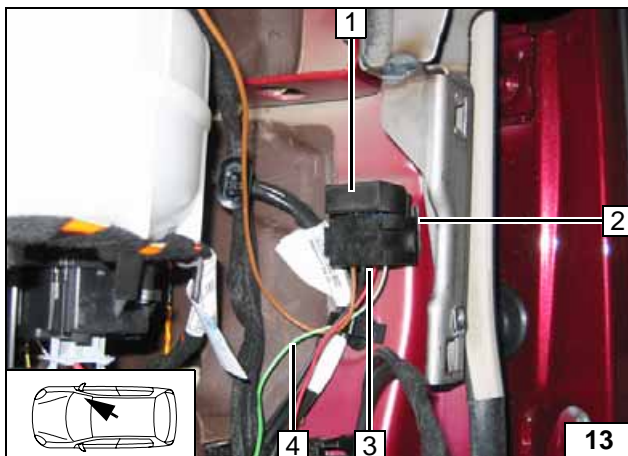

All vehicles

Before installing, connect green/white (gn/ws) wire 4 from K3/86 to base of IPCU 3 terminal 86.

- 1 IPCU
- 2 Double-sided adhesive tape



**Installing
base from
IPCU**

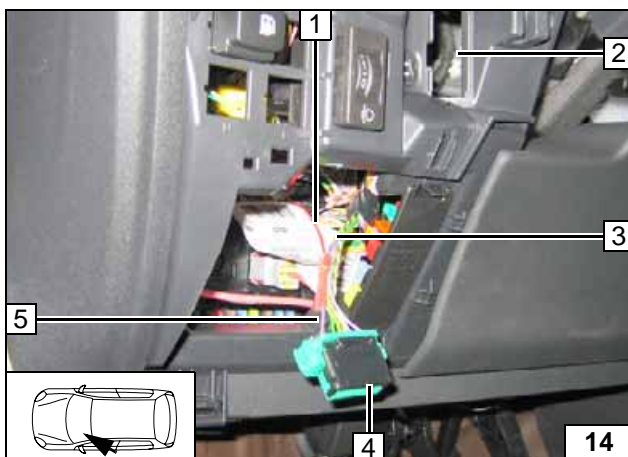

Control changeover of IPCU is carried out on 16-pin OBD socket outlet 4. Produce connections as shown in wiring diagram.

- 1 Red (rt) wire IPCU/15
- 2 Socket of OBD socket outlet
- 3 Pink (pk) wire (terminal 15)
- 5 Pink (pk) wire of OBD socket outlet, Pin 1

**Power sup-
ply of IPCU**

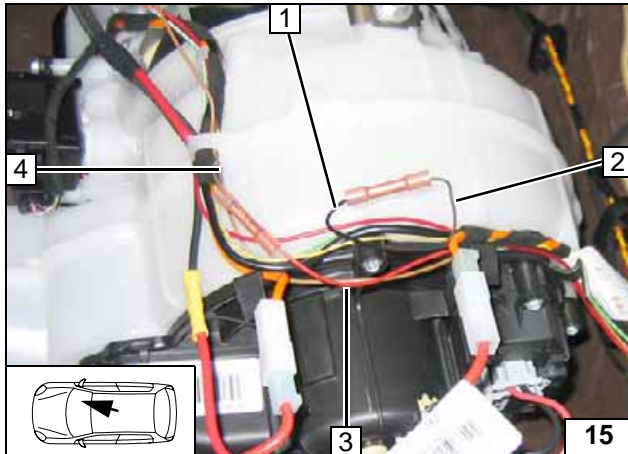
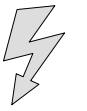

Model year up to 2009

Produce connections as shown in wiring diagram.
The control takes place before the fan controller connector.

- 1 Black (sw) wire of IPCU/A
- 2 Yellow/gray (ge/gr) wire on connector of fan controller
- 3 Red (rt) wire of IPCU/E
- 4 Yellow/gray (ge/gr) wire on connector of A/C control panel



**Connect-
ing fan
controller**

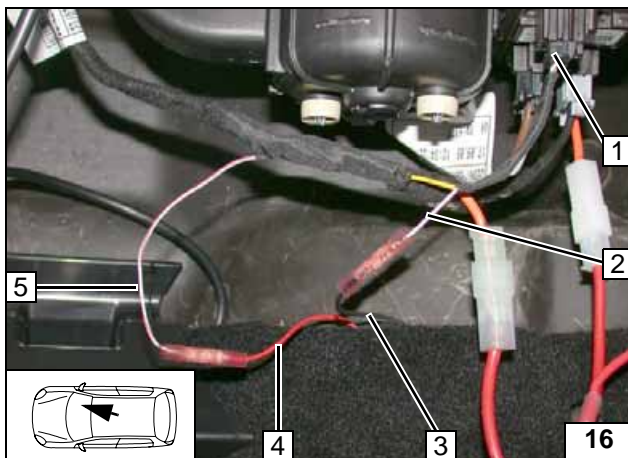

Model year from 2010

The control takes place at connector 1 from fan controller.
Produce connections as shown in wiring diagram.

- 2 White-red (ws/rt) wire of fan motor connector
- 3 Black (sw) wire of IPCU/A
- 4 Red (rt) wire of IPCU/E
- 5 White-red (ws/rt) wire of A/C control panel



**Connect-
ing fan
controller**

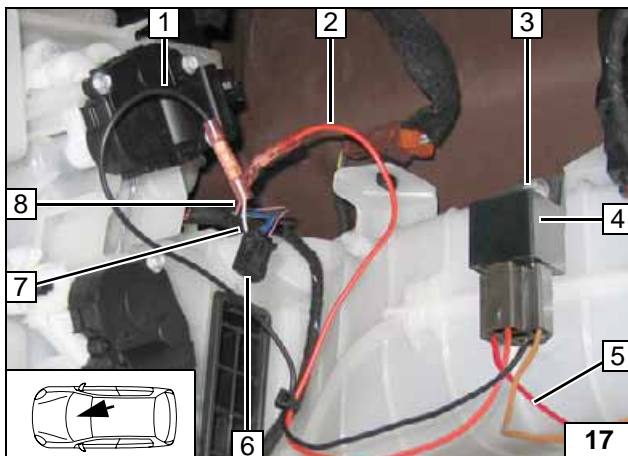

Model year up to 2009

Connect red (rt) wire 5 of IPCU/15 to K3.1/86 according to wiring diagram.
Control changeover of air distribution is carried out at connector 6 from flap motor.
Produce connections as shown in wiring diagram.

- 1 Black (sw) wire K3.1/30
- 2 Red (rt) wire to K3.1/87
- 3 Self-tapping screw on existing hole
- 4 K3.1 relay
- 7 White-red (ws/rt) wire of flap motor connector
- 8 White-red (ws/rt) wire of A/C control panel



**Installing
K3.1 relay,
connect-
ing air dis-
tribution**

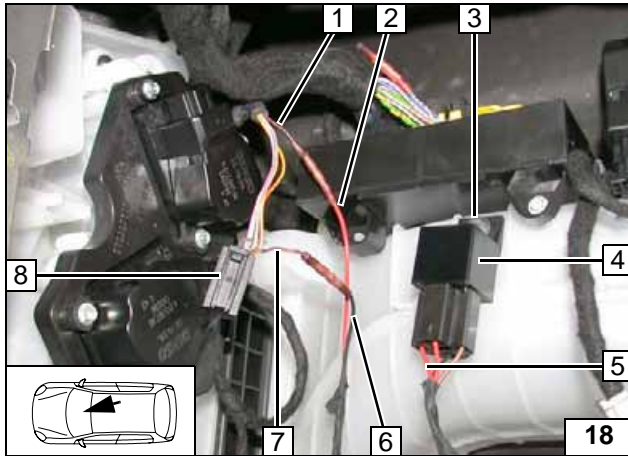
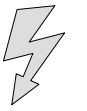

Model year from 2010

Connect red (rt) wire **5** of IPCU/15 to K3.1/86 according to wiring diagram. Control changeover of air distribution is carried out at connector **8** from flap motor. Produce connections as shown in wiring diagram.

- 1 Brown/black (br/sw) wire of A/C control panel connector
- 2 Red (rt) wire to K3.1/87
- 3 Self-tapping screw on existing hole
- 4 K3.1 relay
- 6 Black (sw) wire K3.1/30
- 7 Brown/black (br/sw) wire of A/C flap motor connector

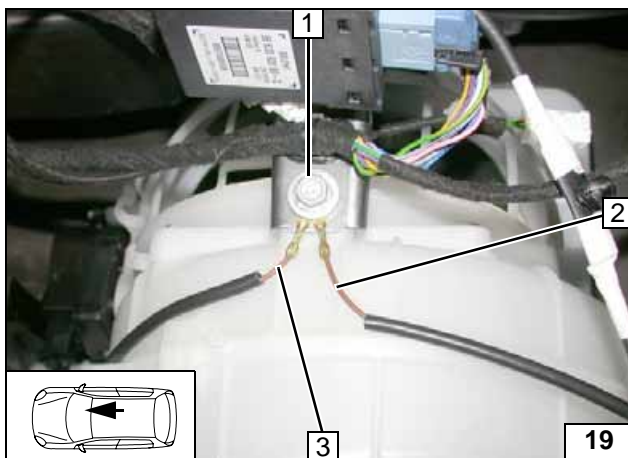

All vehicles

- 1 Original vehicle bolt
- 2 Brown (br) wire of IPCU/85, 6 mm dia cable lug
- 3 Brown (br) wire of K3.1/85, 6 mm dia cable lug



Installing K3.1 relay, connecting air distribution

Ground connection K3.1 and IPCU

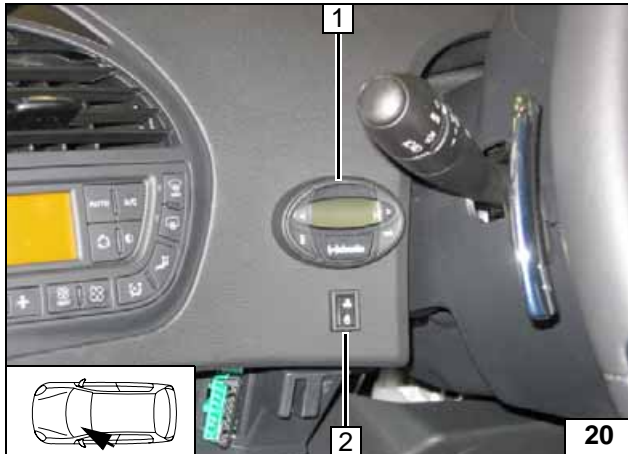
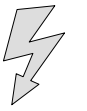

Digital timer, optional Summer/winter switch option

- 1 Digital timer
- 2 12 mm dia. hole, summer/winter switch



Installing digital timer

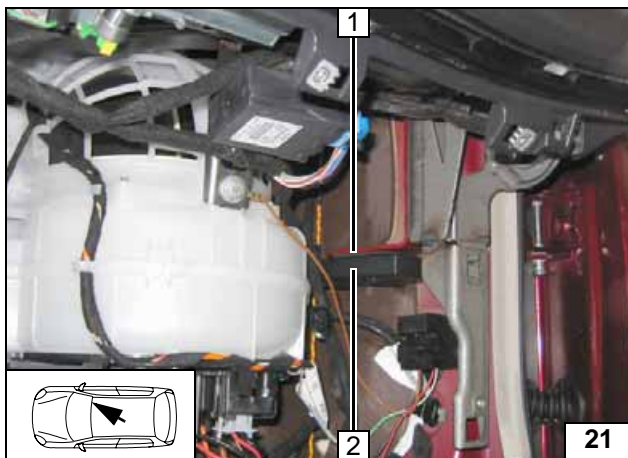

Remote option (Telestart)

- 1 Double-sided adhesive tape
- 2 Receiver



Installing receiver

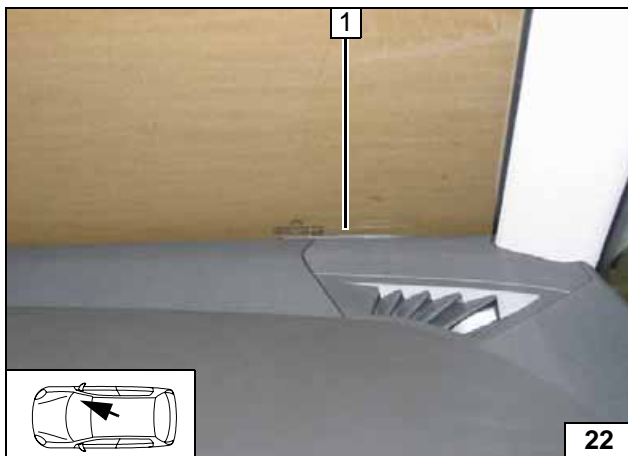

- 1 Antenna

Installing antenna

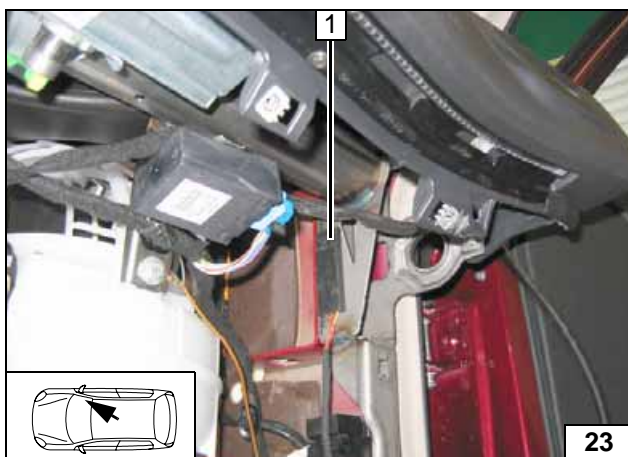

Temperature sensor only for T100 HTM

Fasten temperature sensor 1 with adhesive tape.



Installing temperature sensor

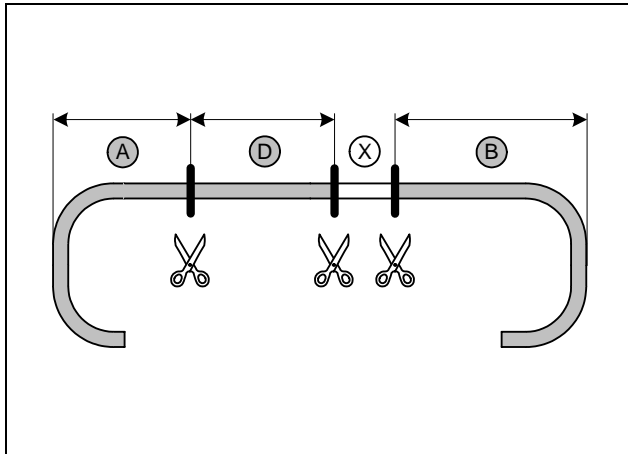
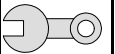

Preparing heater

Discard section X

- A = 330
- B = 630
- D = 350



Cutting hose 1 to length

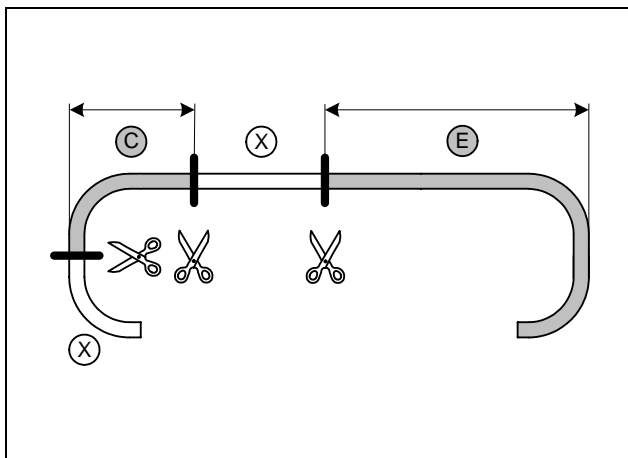

Discard section X

- C = 240
- E = 930



Cutting hose 2 to length

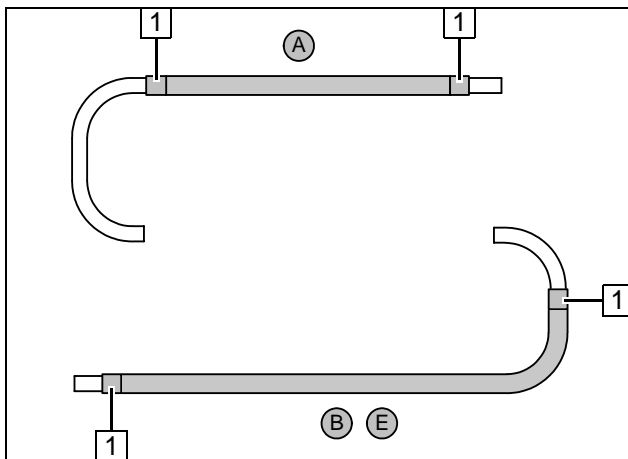

Push braided protection hoses onto hose **A**, **B** and **E** and cut to length.
Cut heat shrink plastic tubing to length and shrink on.

- 1 25 mm long heat shrink plastic tubing [6x]



Preparing hoses

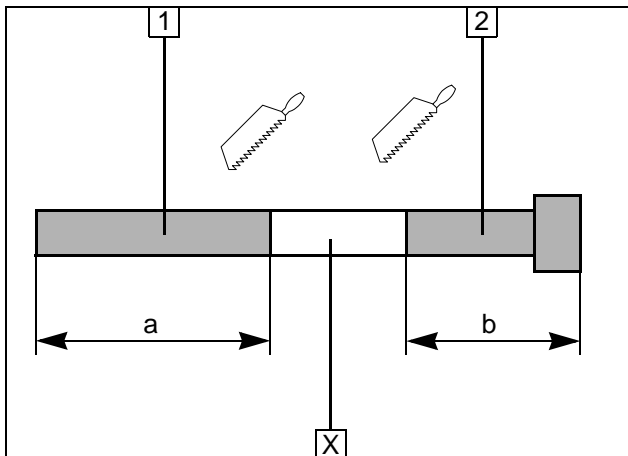

- 1 Exhaust pipe
a = 120
- 2 Exhaust end section
b = 110

Discard section X

Preparing exhaust pipe

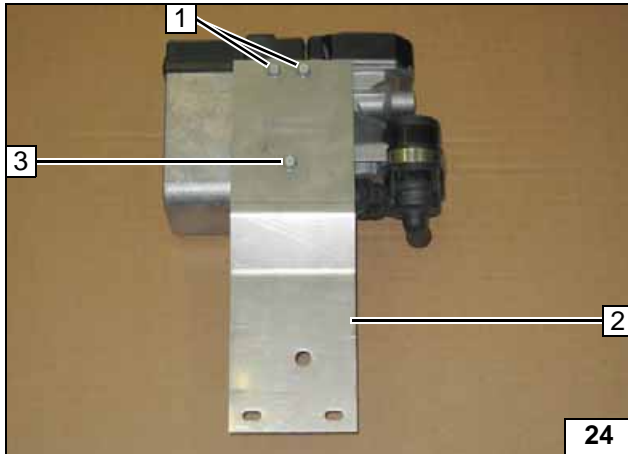
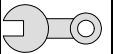

Insert two washers between bracket 2 and heater at position 3.

- 1 E-jot screw [2x]
- 3 E-jot screw, washer [2x]



Installing bracket

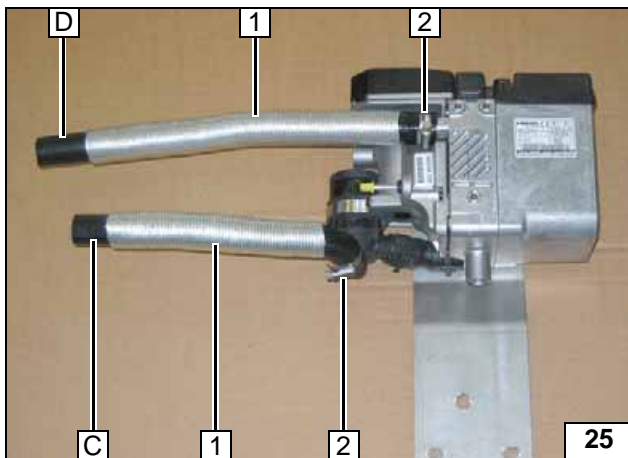

Slide heat protection hose 1 [2x] onto hose C and D and cut to length.

- 2 Hose clamp [2x]



Preamounting hoses

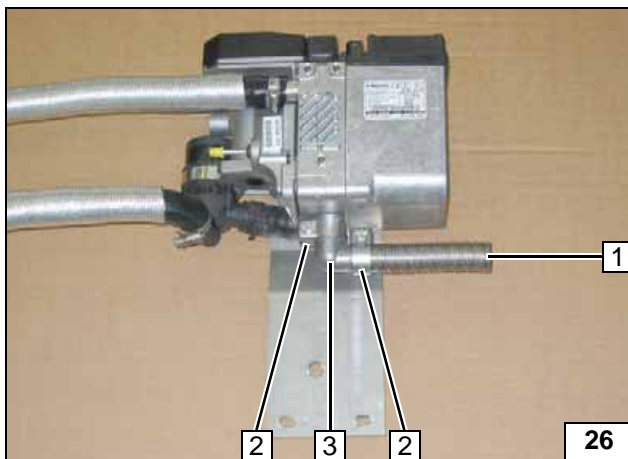

- 1 Exhaust pipe
- 2 Hose clamp [2x]
- 3 Exhaust manifold

Preassembling exhaust pipe

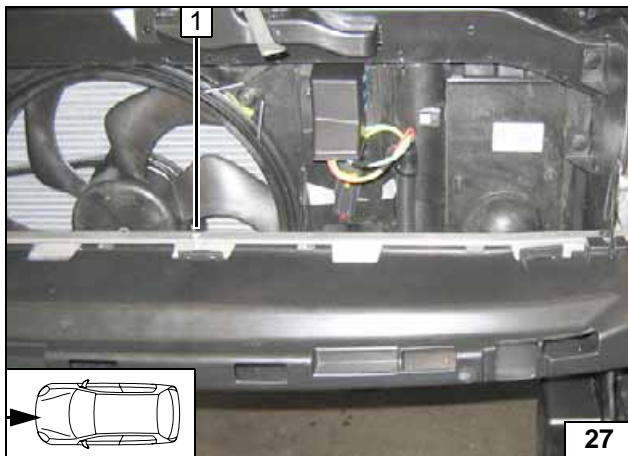

Preparing installation location

Hole at the centre of the bumper.

- 1 Drill 9.1 mm dia. hole; rivet nut



Mounting rivet nut

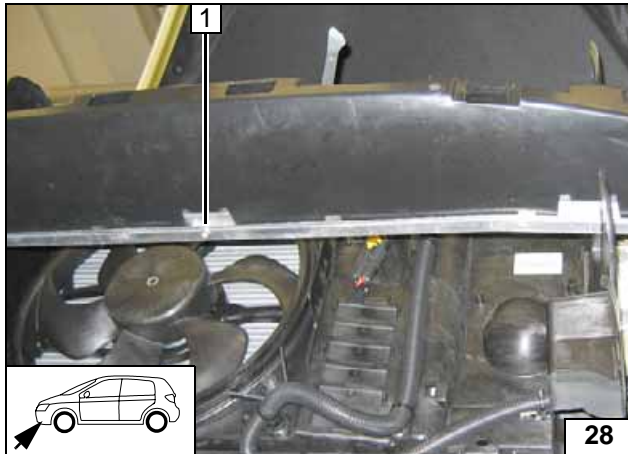
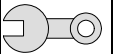

Hole at the centre of the bumper.

- 1 Drill 9.1 mm dia. hole; rivet nut



Mounting rivet nut

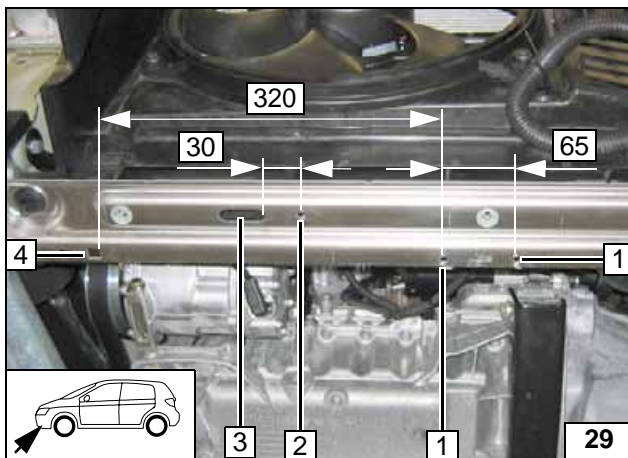

Rectangular recess at Position 4, recess for oblong hole at Position 3!

- 1 7 mm dia. hole [2x] (centered from bar)
- 2 7 mm dia. hole



Holes in the radiator cross member

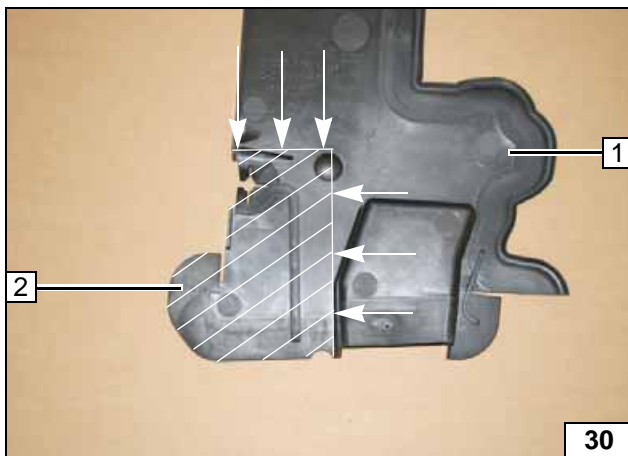

Cut away left partition wall 1 at markings.

- 2 Discard section



Cutting out partition wall

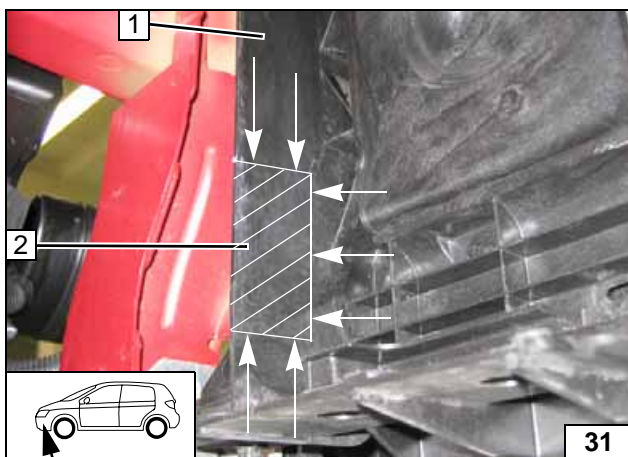

Cut away side section of radiator carrier 1 at markings.

- 2 Discard section



Cutting out radiator carrier

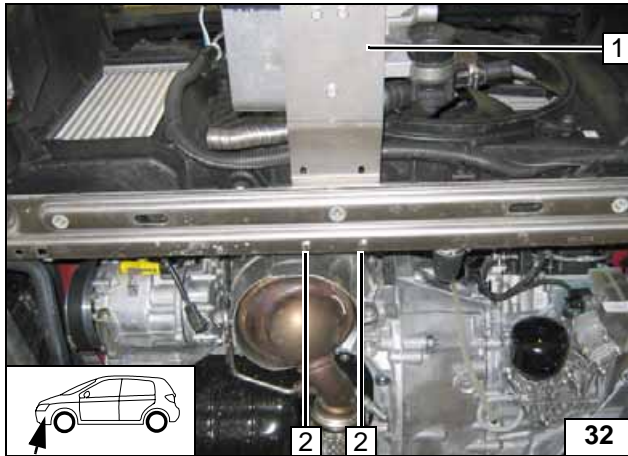
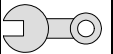

Installing heater

Install one shim 10 each at position 2 between bracket and radiator cross member.

- 1 Preassembled heater
- 2 M6x25 bolt, 10mm shim, flanged nut [2x each]



Installing heater

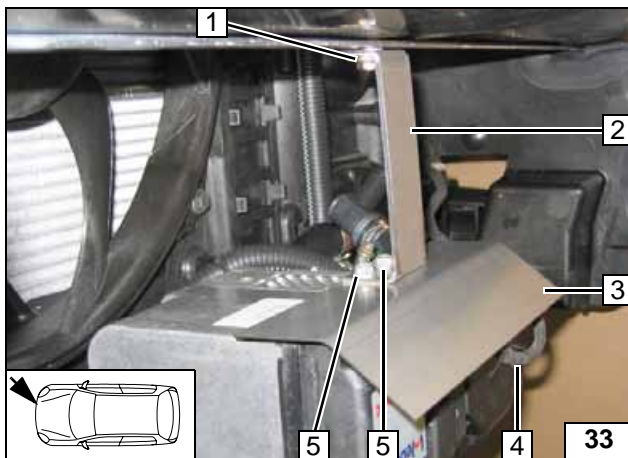

Before installing wind deflector plate 3, mount wiring harness of heater 4.

- 1 Loosely mount M6x20 bolt, spring lockwasher and large diameter washer
- 2 Strut
- 5 Loosely mount Eject screw [2x]



Installing strut

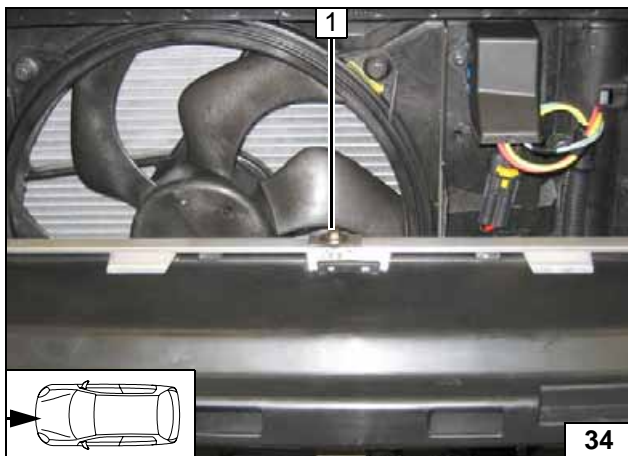

Tighten all connections following installation.

- 1 M6x20 bolt, spring lockwasher, large diameter washer



Installing strut

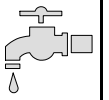



Coolant circuit

WARNING!

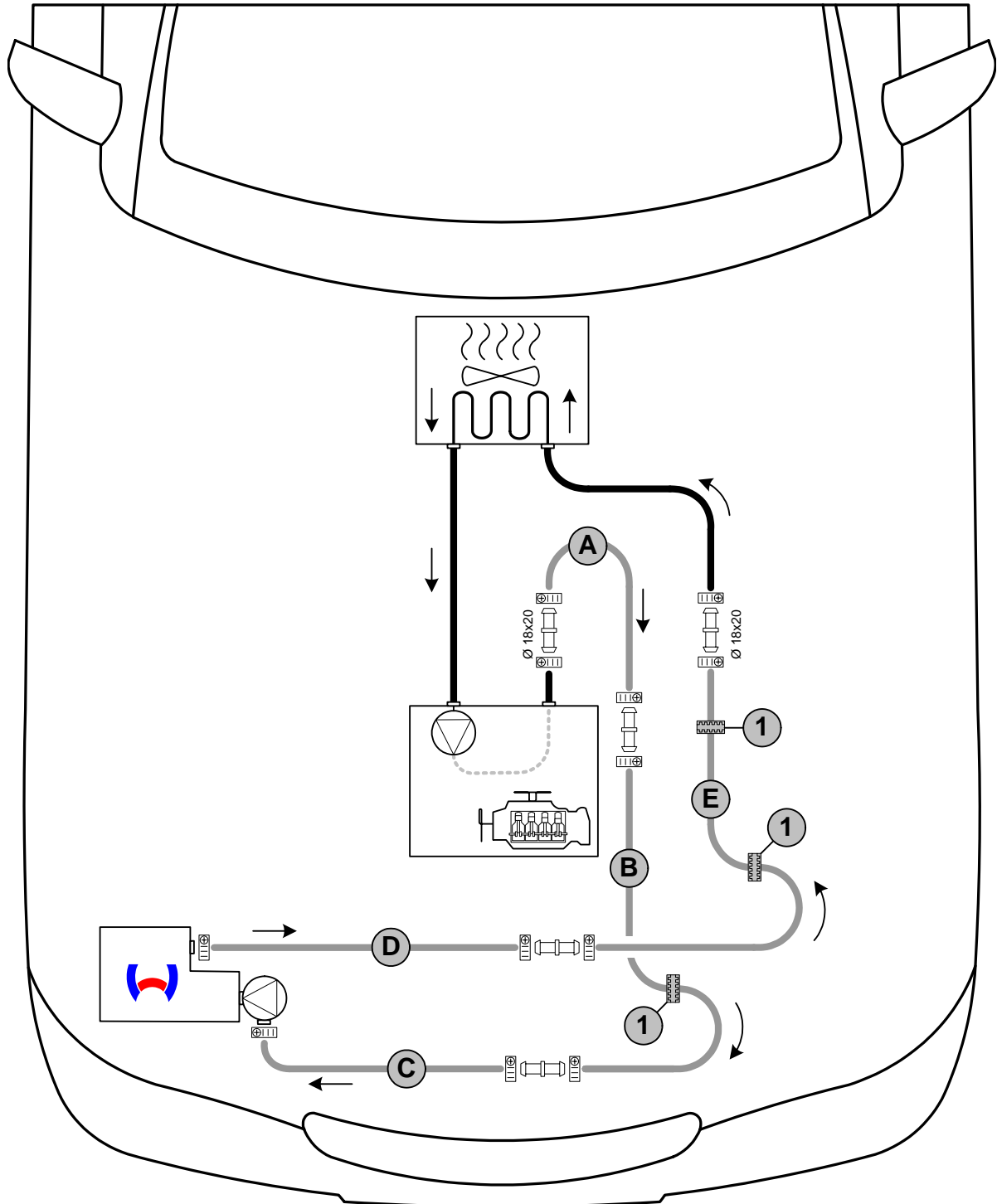
Any coolant running off should be collected using an appropriate container! Route coolant hoses kink-free! Unless specified otherwise, always fasten using cable ties. Position clamps so that no other hose can be damaged! When installing the hoses, the heater must be filled with coolant. The connection should be "inline" based on the following diagram:



Hose routing diagram

All hose clamps  = 20-27 mm dia.!
 All connecting pipes without a specific designation  = dia. 20x20.
 1 = Black (sw) rubber isolator .



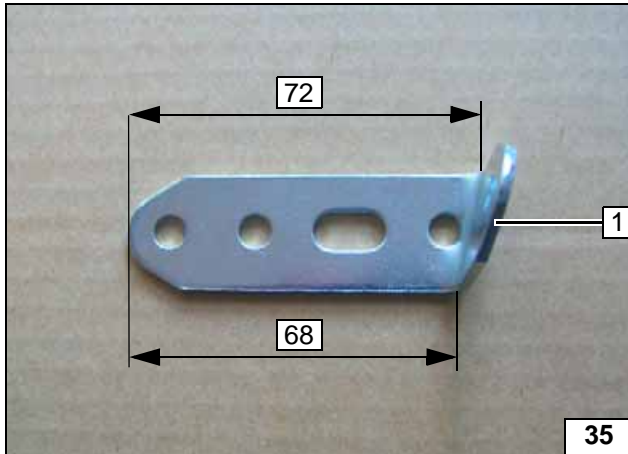

1 Angle down perforated bracket by approx. 80°.

Angling down perforated bracket

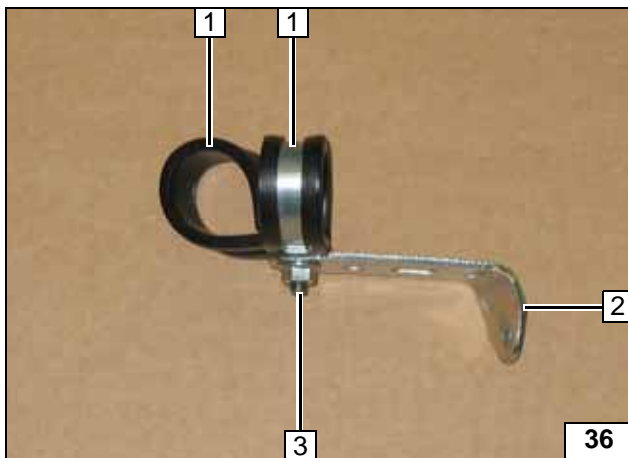

1 29 mm dia. rubber-coated p-clamp [2x]
2 Perforated bracket
3 M6x20 bolt, flanged nut

Installing pipe clamps

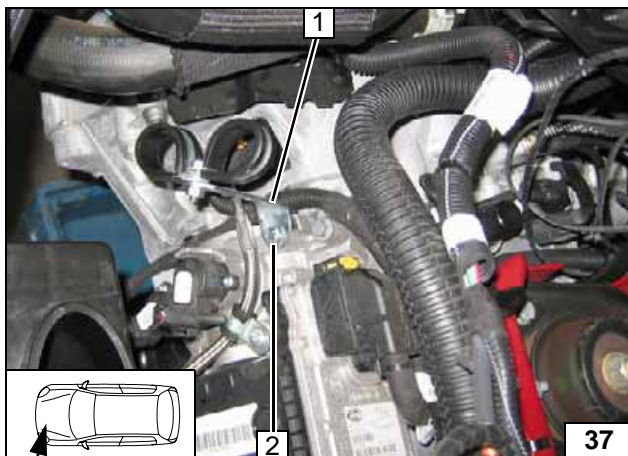

1 Perforated bracket on hole of transmission
2 M6x20 bolt, spring lockwasher

Installing perforated bracket

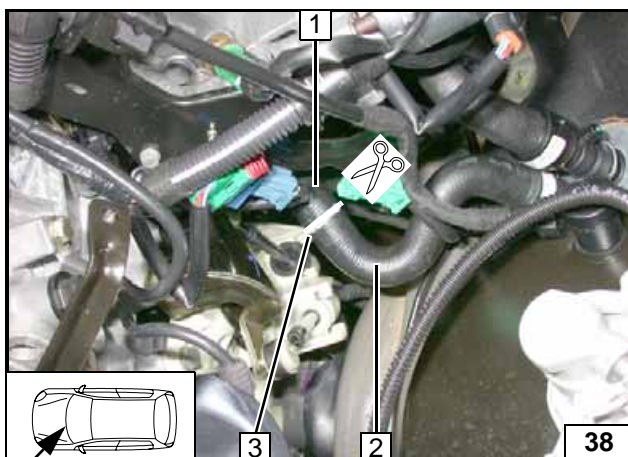

1 Engine-outlet hose section
2 Hose section of heat exchanger inlet
3 Cutting point

Cutting point

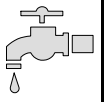

Before installation, push black (sw) rubber isolator **2** onto hose **E**.

- 1** Hose section of heat exchanger inlet
- 2** Black (sw) rubber isolator with cable tie on bracket of battery carrier



**Connect-
ing heat
exchanger
inlet**

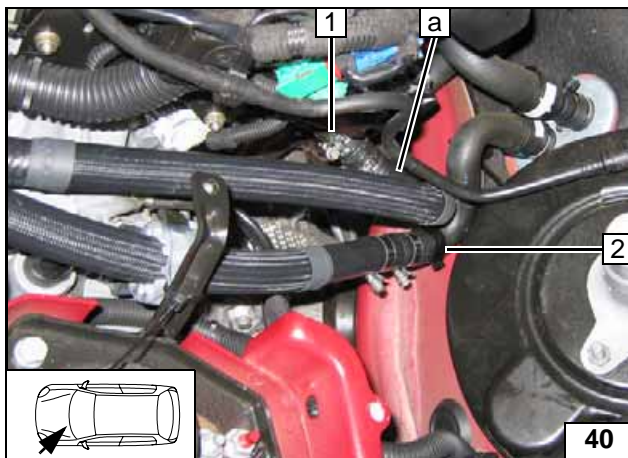

- 1** Hose of engine outlet
- 2** Spacer bracket

**Connect-
ing engine
outlet**

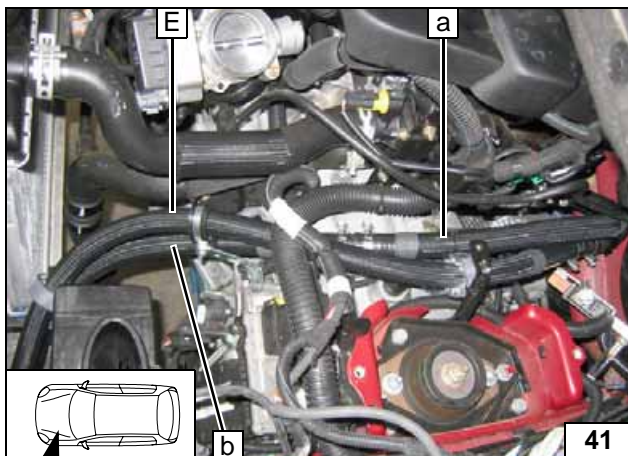

Route hose **B** and **E** through rubber-coated p-clamps. Only loosely preassemble hose **A** and **B** (hose clamps will be tightened later).



**Routing in
engine
compart-
ment**

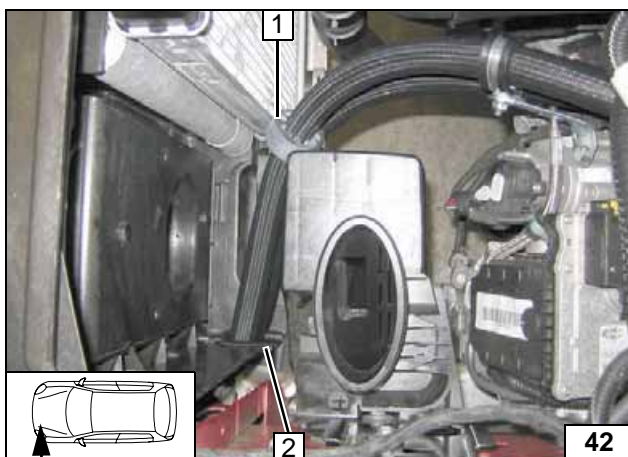

Before installation, slide black (sw) rubber isolator **1** [2x] onto hose **B** and **E**.

- 2** 100 mm edge protection



**Routing in
engine
compart-
ment**

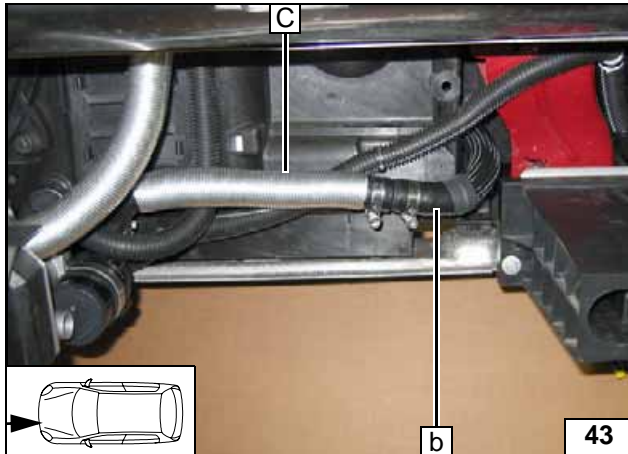
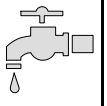

Align hoses and tighten hose clamps at connecting point of hose **A** and **B**.



**Connect-
ing heater
inlet**

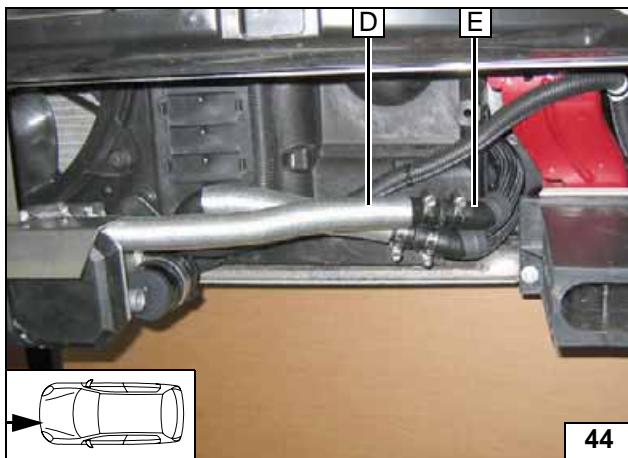

Check the position of the components; adjust if necessary. Check that they have free clearance.



**Connect-
ing heater
outlet**

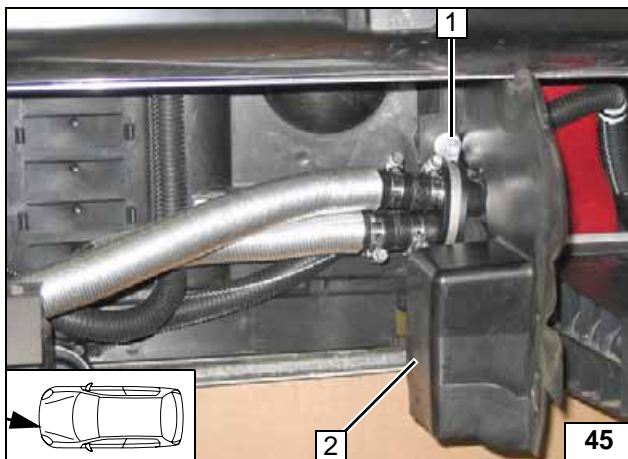

Fasten hose **B** and **E** with rubber-coated p-clamp together with partition wall **2**.



- 1** M6x40 bolt, 48 mm dia. rubber-coated p-clamp, 20 mm shim, flanged nut on original vehicle hole for clip

**Fastening
hoses**

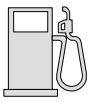

Fuel

CAUTION!

Open the vehicle's fuel tank cap, ventilate the tank and then re-close the tank lock.

Catch any fuel running off with an appropriate container.

Install fuel line and metering-pump wiring harness so that they are protected against stone impact. Unless specified otherwise, always fasten using cable ties. Mount the fuel line and wiring harness with rub protection on sharp edges.

WARNING!

The fuel line and wiring harness are routed to the metering pump in as shown in the wiring harness routing diagram.

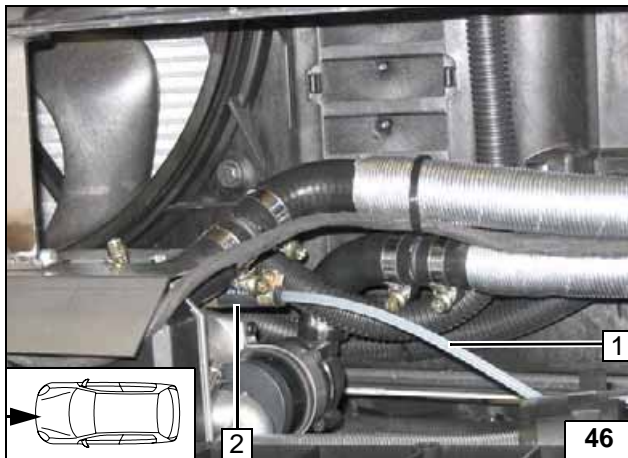

- 1 Fuel line
- 2 Hose section, 10 mm dia. clamp [2x]

Conne-
ction on
heater

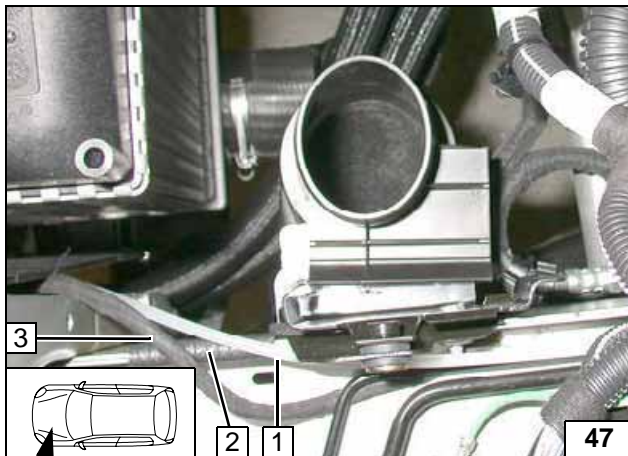

Route wiring harness of metering pump 3 and fuel line 1 on the side member to the firewall and further to the underbody.

- 2 70 mm edge protection



Installing
lines

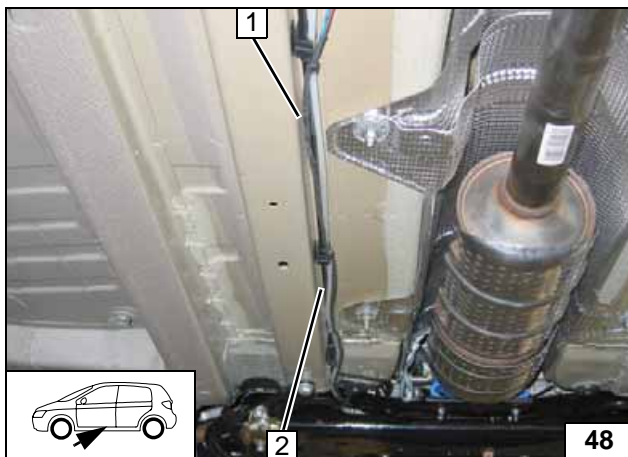

- 1 Metering pump wiring harness
- 2 Fuel line from heater

Installing
lines

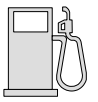

Remove fuel tank and fuel-tank sending unit 1 according to manufacturer's information.

- 2 Large diameter washer
- 3 Copy hole pattern, 6 mm dia. hole



Removing fuel

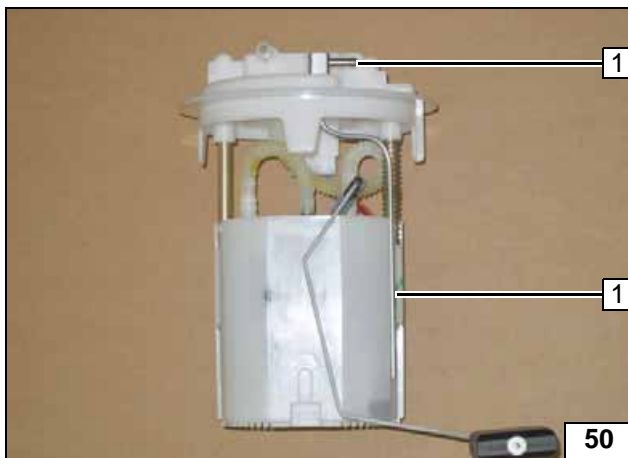

Shape fuel standpipe 1 according to template, cut to length and install.



Installing fuel standpipe

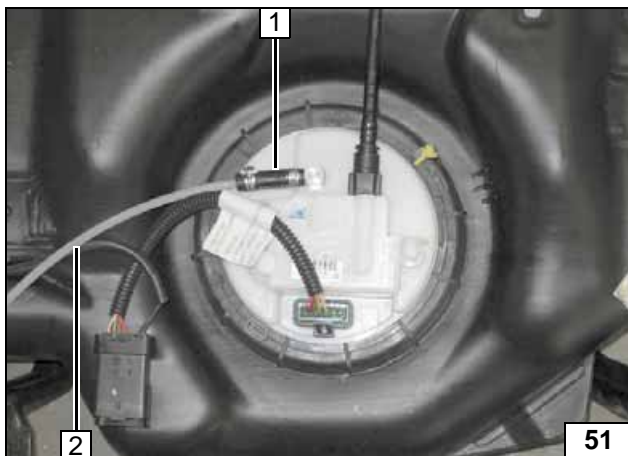

Install fuel-tank sending unit according to manufacturer's specifications.
Install fuel tank in accordance with manufacturer's specifications.

- 1 Hose section, 10 mm dia. Caillau clamp [2x]
- 2 Fuel line



Connecting fuel line

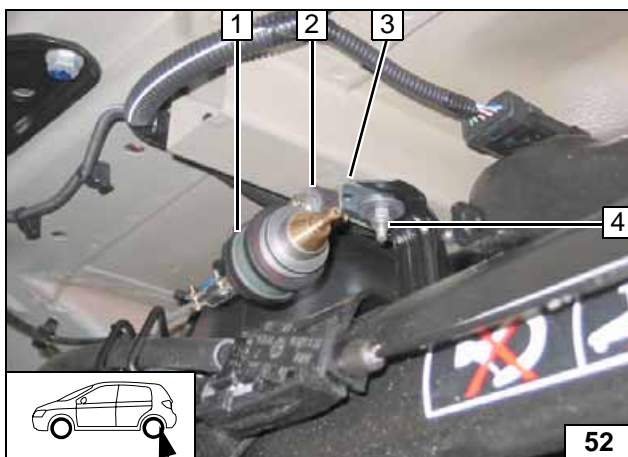

- 1 Rubber-coated pipe clamp
- 2 Silent block, flanged nut [2x]
- 3 Angle bracket
- 4 Original vehicle nut, washer



Installing metering pump

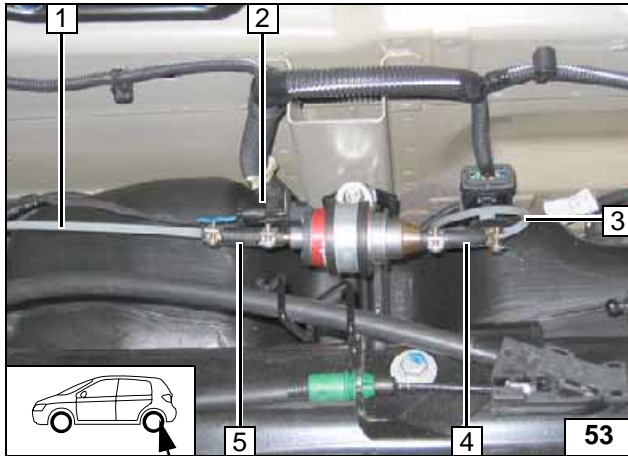
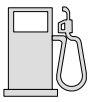

- 1 Fuel line from heater
- 2 Wiring harness of metering pump, connector mounted
- 3 Fuel line from fuel standpipe
- 4 Hose section, 10 mm dia. clamps [2x]
- 5 Hose section, 10 mm dia. clamps [2x]



**Connect-
ing meter-
ing pump**

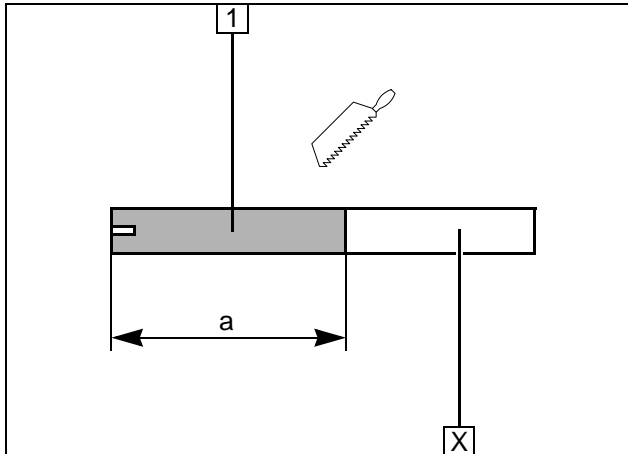
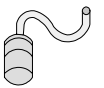

Combustion air

- 1 Combustion air pipe
a = 250

Discard section X

Cutting combustion air pipe to length

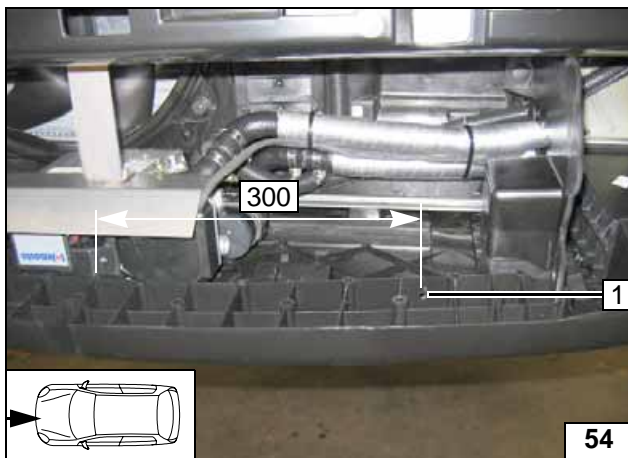

Drill 6.2 mm dia. hole 1 in centre of grid as shown in figure.



Hole for muffler

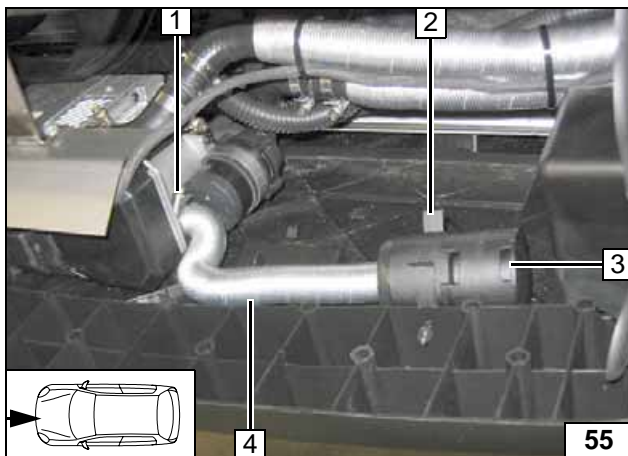

Ensure proper installation position of air intake muffler, see "Installation Instructions". Check the position of the components; adjust if necessary. Check that they have free clearance.

- 1 27 mm dia. hose clamp
- 2 Retaining clip in hole
- 3 Combustion-air intake muffler
- 4 Combustion-air intake pipe



Installing combustion air pipe

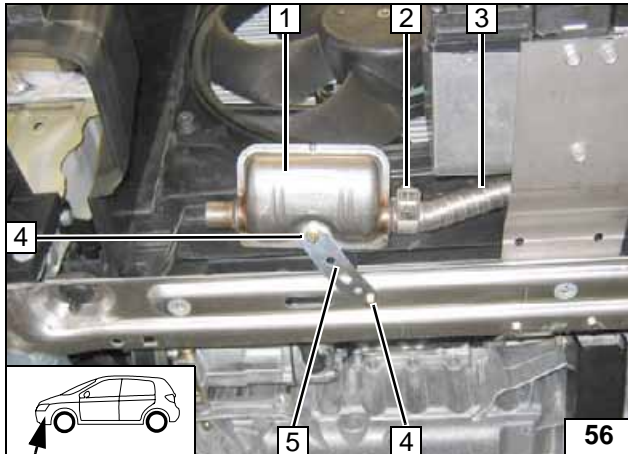
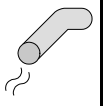

Exhaust gas

Following installation, align muffler upward approx. 30°.

- 1 Muffler
- 2 Hose clamp
- 3 Exhaust pipe
- 4 M6x20 bolt, flanged nut [2x each]
- 5 Perforated bracket

Installing exhaust system

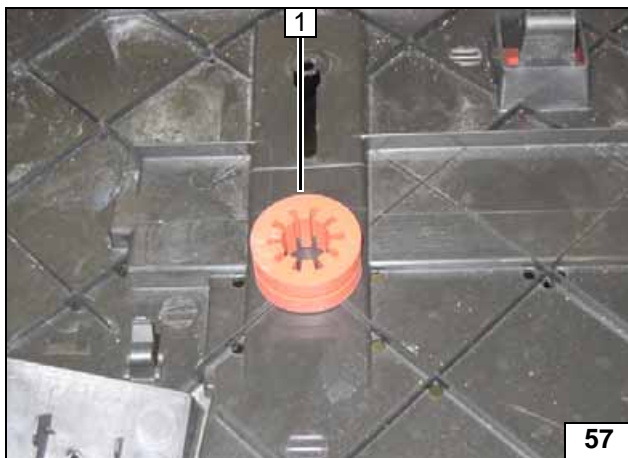

Lay on red (rt) rubber isolator at position 1, copy hole pattern and drill 106.68 cm dia. hole in underide protection.

Cutting out underide protection

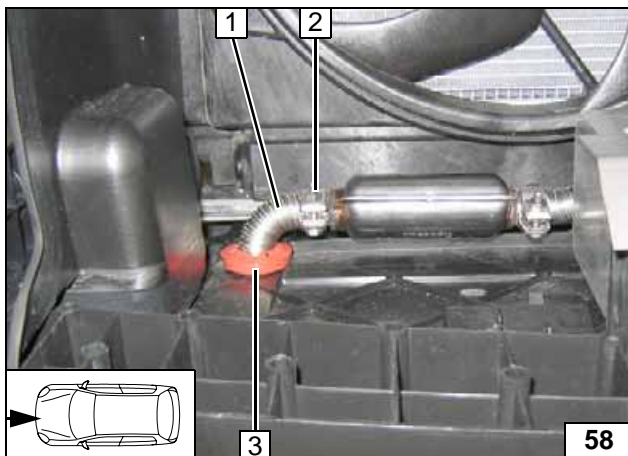

Insert rubber isolator 3 in 42 mm dia. hole. Check the position of the components; adjust if necessary. Check that they have free clearance.

- 1 Exhaust end section
- 2 Hose clamp

Installing exhaust end section



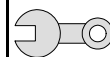

Final Work

WARNING!

Mount removed parts in reverse order.

Check all hoses, clamps and all electrical connections for firm seating.

Secure all loose cables using cable ties.

Only use manufacturer-approved coolant.

Spray heater components with anti-corrosion wax (Tectyl 100K, Order No. 111329).

- Connect the battery.
- Fill and bleed the coolant circuit according to the vehicle manufacturer's specifications.
- Set the digital timer.
- Make settings on A/C control panel according to the "Operating Instructions for End Customer".
- Check the proper operation of the parking heater, see the operating instructions/installation instructions.
- Attach instruction label "Switch off parking heater before refueling" in the area of the filling neck

Note:

Check current intake of fan motor during first startup and adjust to approx. 4.5 A; correct if necessary (Change duty cycle)!



Webasto AG
Postfach 80
D-82132 Stockdorf / Germany
National Hotline: 01805 93 22 78
(14 Cent aus dem deutschen Festnetz)
Hotfax: 0395 5592 353
Hotmail: technikcenter@webasto.com
<http://www.webasto.de>

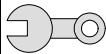

Template for Fuel Standpipe

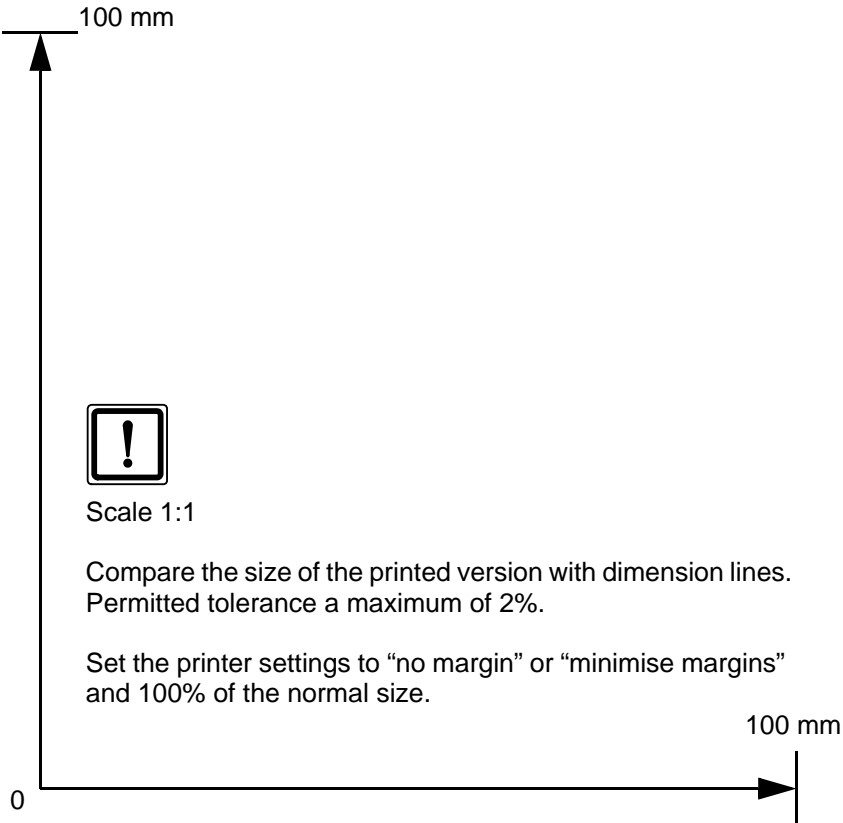
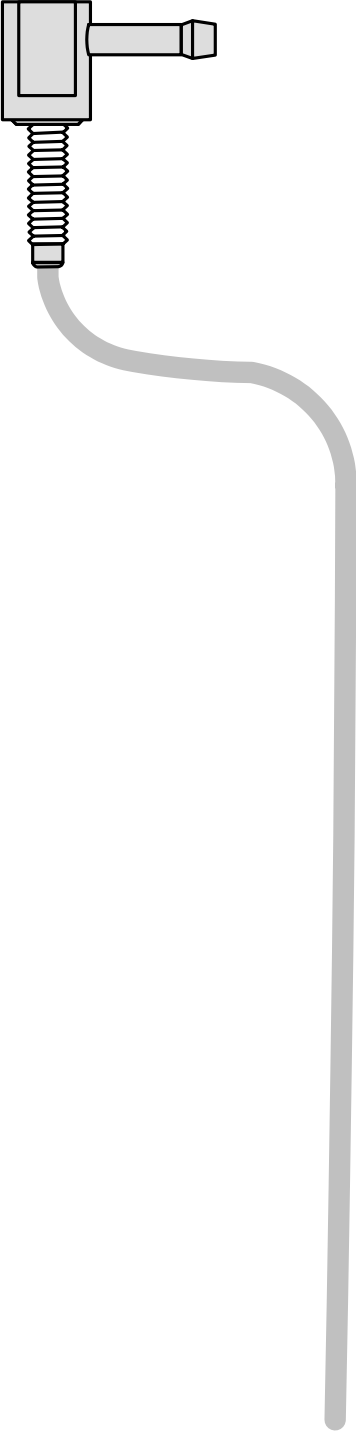

Operating Instructions for End Customer



Please remove page and add to the vehicle operating instructions.

Note:

We recommend matching the heating time to the driving time.

Heating time = driving time

Example:

For a driving time of approx. 20 min. (in one direction), we recommend not exceeding a switch-on time of 20 min.

If the summer/winter switch option has been installed, this must be switched in accordance with the time of year. The heater will then only switch on the vehicle fan to ventilate the vehicle interior in the position Winter heat and in the position Summer .



Before shutting off the engine, make the following settings:



1 Air outlet to windshield



1 Air outlet to windshield

Manual air conditioning

Automatic air-conditioning