

Water Heater



Thermo Top E Parking Heater

e1
00 0003

Thermo Top C Parking Heater

e1
00 0002

Installation documentation

VW Golf VI, Golf Plus, Golf Variant

1.6 and 2.0 TDI Common Rail

from Model Year 2008

Left-hand drive vehicle

Adaptation of the sensitivity of the passenger compartment monitoring not checked.



WARNING!

Hazard warning:

Incorrect installation or repair of Webasto heating systems may cause a fire or result in the emission of carbon monoxide, which can be fatal. Serious or fatal injuries can be caused as a result.



Specialist company training, technical documentation, specialised tools and equipment are required to install and repair Webasto heating and cooling systems. Only original Webasto parts must be used. For this, also see the catalog of air and water heater accessories from Webasto.

NEVER attempt to install or repair Webasto heating or cooling systems if you have not successfully completed the company training and thereby acquired the required technical skills, or if you do not have access to the required technical documentation, tools and equipment needed to carry out correct installation and repairs.

ALWAYS follow all Webasto installation and repair instructions and observe all warnings.

Webasto does not accept any liability for defects and damage that are attributable to installation by untrained staff.

Table of Contents

| | | | |
|--|----|---|----|
| Validity | 2 | Premounting heater | 14 |
| Heater/Installation Kit | 3 | Preparing exhaust system | 15 |
| Foreword | 3 | Preparing coolant circuit | 16 |
| General Instructions | 3 | Installing heater | 20 |
| Special Tools | 3 | Fuel | 21 |
| Explanatory Notes on Document | 4 | Coolant circuit 1.6 TDI | 24 |
| Preliminary Work | 5 | Coolant circuit 2.0 TDI | 27 |
| Heater installation location | 5 | Exhaust gas | 32 |
| Electrical system | 6 | Final Work | 33 |
| Fuse holder and K3 relay | 7 | Operating Instructions for End Customer | 34 |
| Climatic fan control | 8 | | |
| Climatronic fan control | 10 | | |
| Digital timer, summer/winter switch option | 12 | | |
| Remote option (Telestart) | 12 | | |

Validity

| Manufacturer | Model | Type | EG-BE No./ABE |
|--------------|--------------|------|------------------------------|
| VW | Golf VI | 1K | e1 * 2001/116 * 0242 * ... |
| VW | Golf Plus | 1KP | e1 * 2001/116 * 0304 * ... |
| VW | Golf Variant | 1KM | e1 * 2001 / 116 * 0328 * ... |

| Engine type | Engine model | Output in kW | Displacement in cm ³ |
|-------------|--------------|--------------|---------------------------------|
| CAYC | Diesel | 77 | 1598 |
| CBDC | Diesel | 81 | 1968 |
| CBAB | Diesel | 103 | 1968 |
| CBBB | Diesel | 125 | 1968 |

Vehicle and engine types, equipment variants and national specifications not listed in this installation documentation have not been tested. However, installation according to this installation documentation may be possible.

The installation location of a digital timer and summer/winter switch should be confirmed with the end customer before installation.

Heater/Installation Kit

| Quantity | Description | Order No.: |
|----------|---|----------------|
| 1 | Retail accessories Thermo Top E / C | See price list |
| 1 | Installation Kit for VW Golf VI 1.6 and 2.0 TDI Common Rail | 1314422C |
| 1 | Heater control | See price list |

Also required with Climatronic:

| Quantity | Description | Order No.: |
|----------|--------------------------|------------|
| 1 | IPCU Kit for Climatronic | 9013645A |

Heater recommended for the respective vehicle class:

| Vehicle | Heater |
|-----------------------------|--------------|
| Compact car | Thermo Top E |
| Mid-size car, station wagon | Thermo Top C |

The selection of the heater is based on the passenger compartment size of the vehicle and the level of comfort required by the customer.



Foreword

This installation documentation applies to the vehicles VW Golf VI, Golf Plus, Golf Variant 1.6 and 2.0 TDI Common Rail - for validity, see page 2 - from model year 2008 and later, assuming technical modifications to the vehicle do not affect installation, any liability claims excluded. Depending on the vehicle version and equipment, modifications may be necessary during installation with respect to this installation documentation.

However, the stipulations in the "installation documentation", the "operating instructions" and the "installation instructions" for the *Thermo Top C / E* must always be observed. The corresponding rules of technology and any information from the vehicle manufacturer should be observed during the installation work.

General Instructions

Installation should be carried out according to the general, standard rules of technology. Unless specified otherwise, fasten hoses, lines and wiring harnesses to original vehicle lines and wiring harnesses using cable ties.

Sharp edges should be fitted with rub protection (split-open plastic hose).

Spray unfinished body areas, e.g. drilled holes, with anti-corrosion wax (Tectyl 100K, Order No. 111329).

When installing an IPCU, check or adjust the corresponding settings before installation.

Special Tools

- Torque wrench for 2.0 - 10 Nm
- Hose clamping pliers

Explanatory Notes on Document

You will find an identification mark on the outside top right corner of the page in question to provide you with a quick overview of the individual working steps.

Mechanical system

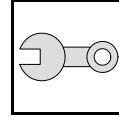

Electrical system

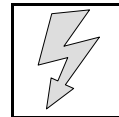

Coolant circuit

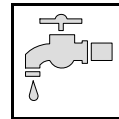

Fuel

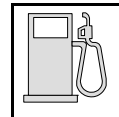

Exhaust gas

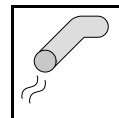

Combustion air

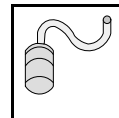

Special features are highlighted using the following symbols:



Specific risk of injury or fatal accidents.



Specific risk of damage to components.



Specific risk of fire or explosion.



Reference to general installation instructions of Webasto components or to the manufacturer's vehicle-specific documents.



Reference to a special technical feature.

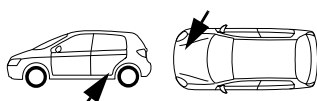

The arrow in the vehicle icon indicates the position on the vehicle and the viewing angle.

All dimensions are in mm!

Tightening torque of hose clamps = 2.0 + 0.5 Nm!

Tightening torque of Ejet screws, Ejet studs = 10 Nm!

Preliminary Work

WARNING!

- Open the fuel tank cap, ventilate the tank.
- Close the fuel tank cap again.
- Depressurise the cooling system.
- Copy the factory number from the original type label to the duplicate type label.
- Remove years that do not apply from the duplicate label.
- Attach the duplicate label (type label) in the appropriate place.
- Disconnect the battery "earth" or "ground" connection.
- Completely remove the battery with the battery carrier.
- Remove the engine cover.
- Detach the coolant reservoir cap.
- Remove the left front wheel.
- Remove the front section of the left front wheel well trim.
- Remove the left-hand front fog light or, on vehicles without front fog lights, the left-hand cover.
- Remove the underride protection
- Remove the right-hand underbody trim.
- Remove the rear bench seat.
- Open the right-hand tank-fitting service lid.
- Remove the footwell trim on the driver's side
- Remove the lower instrument panel trim on the driver's side
- Only vehicles with Climatronic: Remove the footwell trim on the front passenger side

Remove page 34 "Operating Instructions for End Customer" and add to the vehicle operating instructions.

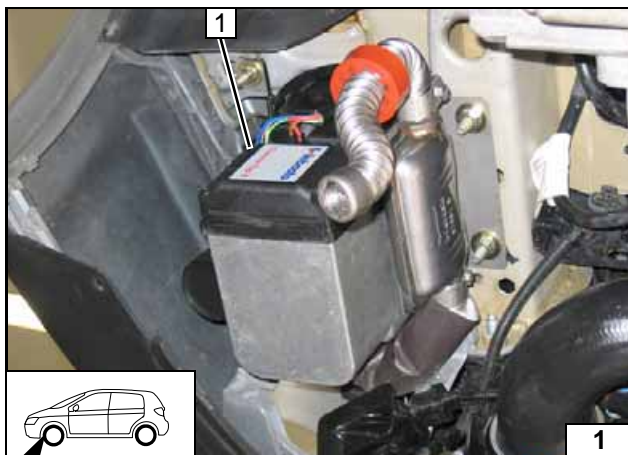

Heater installation location

1 Heater

Installation location



Electrical system

Wiring harness routing

Route excess lengths from wiring harness 1 in cable duct 2 below battery and secure with cable ties.

Wiring harness pass through

1 Original vehicle wiring harness pass through

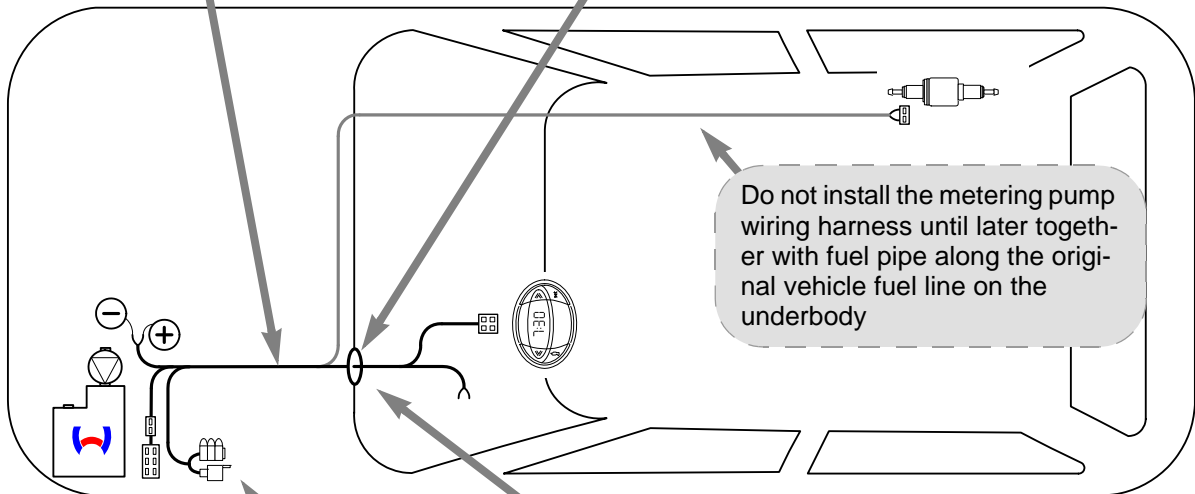
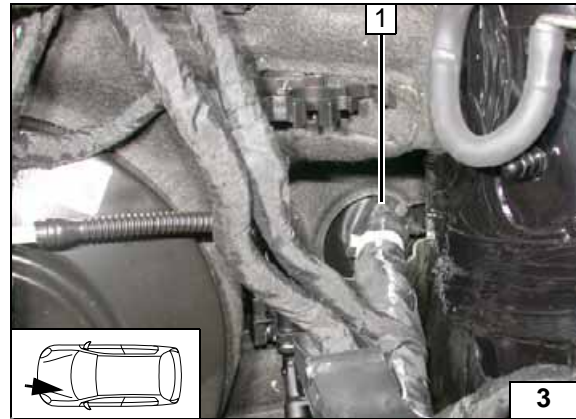
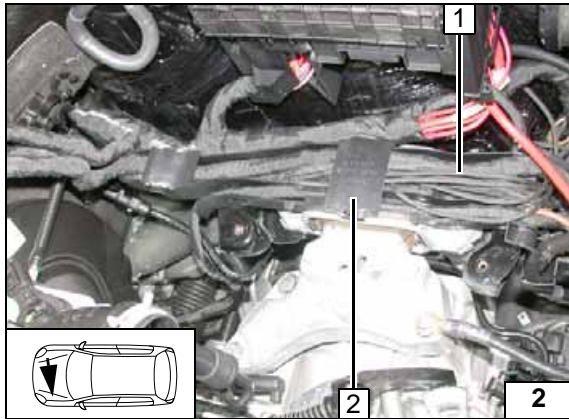

Wiring harness routing diagram

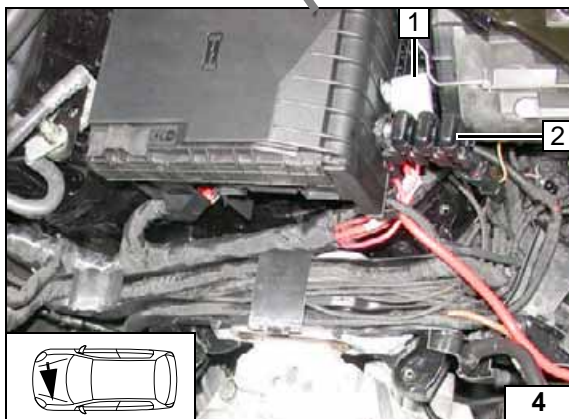

Fuse holder, K3 relay

Installation of K3 relay 1 and fuse carrier 2 on Page 7

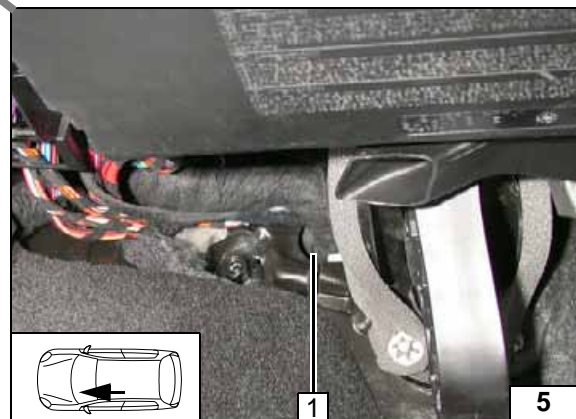

Wiring harness pass through

1 Original vehicle wiring harness pass through

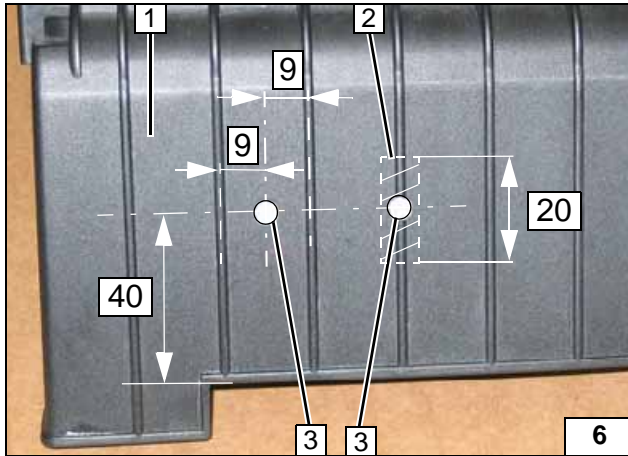
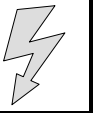

Fuse holder and K3 relay

Countersink holes **3** from behind for M5 countersunk head screws.

- 1** Cover of fuse/relay carrier in engine compartment
- 2** Cut away bar in shaded area
- 3** 5 mm dia. hole [2x]



Holes in cover

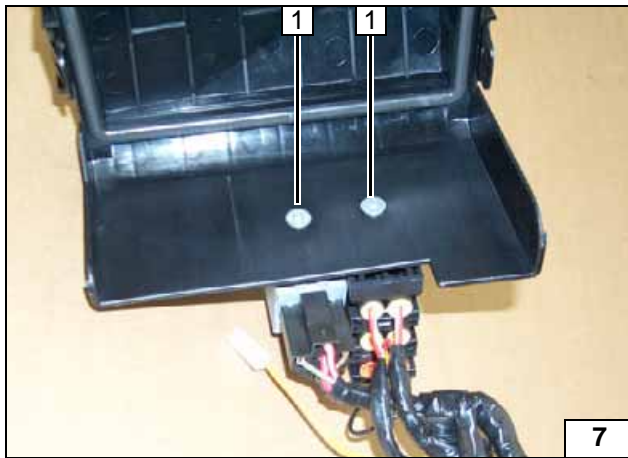

- 1** M5x12 countersunk head screw [2x]

Installing fuse holder and relay K3

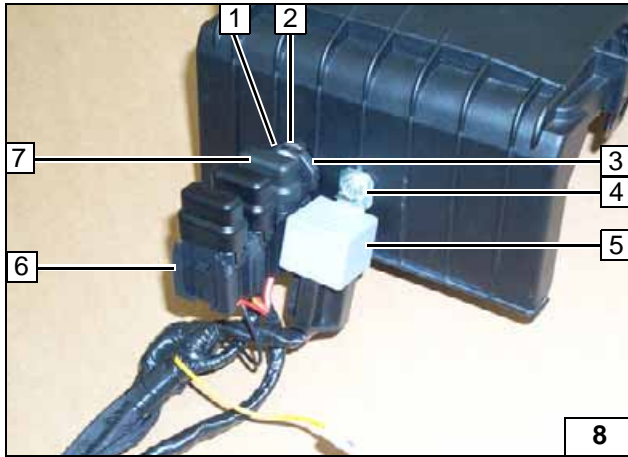

On vehicles with Climatronic, replace 25 A fuse F3 **7** with 3 A fuse provided.

- 1** M5 flanged nut
- 2** Large diameter washer (between cover and retaining plate)
- 3** Retaining plate
- 4** M5 flanged nut
- 5** Relay K3
- 6** Fuse holder



Installing fuse holder and relay K3

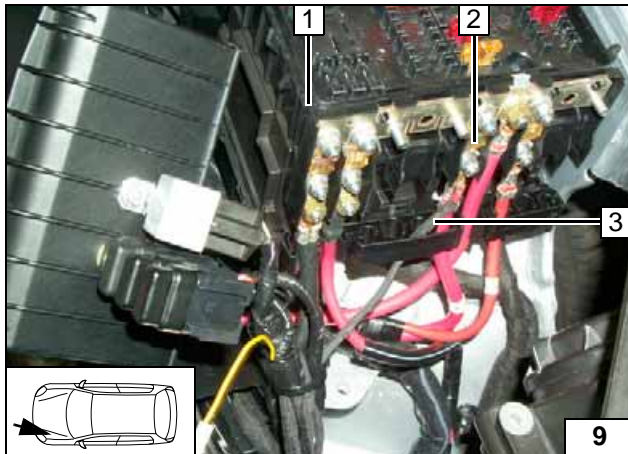

Route brown (br) earth wire to original vehicle earth support point below headlight and connect.

- 1** Fuse/relay carrier
- 2** Original main vehicle fuse
- 3** Red (rt) positive wire



Connecting positive and earth wire



Climatic fan control

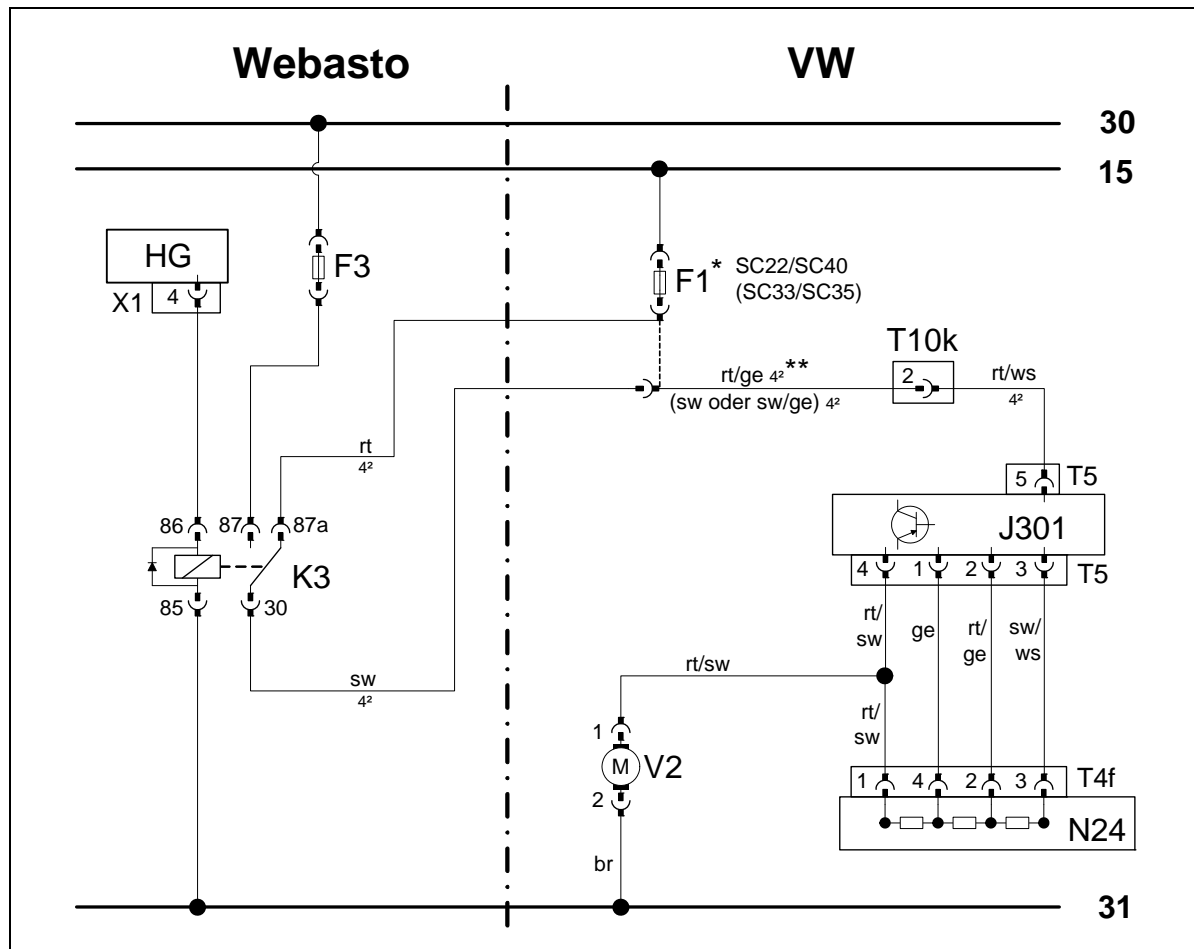

Climatic wiring diagram

| Webasto components | | Vehicle components | | Colours and symbols | |
|--------------------|------------------------|--------------------|--|--------------------------|--|
| HG | Heater TT-C/E | GM | Fan motor | rt | red |
| X1 | 6-pin heater connector | F1* | Fuse 40A (depending on respective fuse assignment) Golf VI = SC22 or SC40 Golf Plus = SC33 or SC35 | ge | yellow |
| F3 | 25 A fuse | | | sw | black |
| K3 | Fan relay | J301 | Control unit of air conditioning | ** | Wire depends on the respective vehicle equipment Golf VI = red/yellow (rt/ge) Golf Plus = black (sw) or black/yellow (sw/ge) |
| | | T5 | 5-pin connector J301 | X | Cutting point |
| | | N24 | Resistor group | Wiring colours may vary. | |
| | | T4f | 4-pin connector N24 | | |
| | | T10k | Connector | | |

Legend

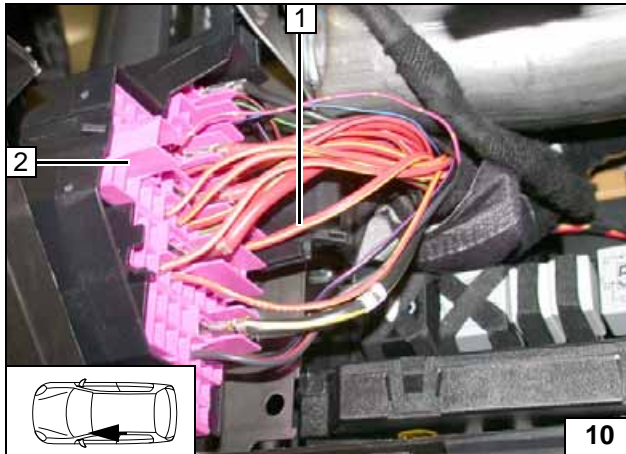
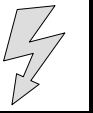

Golf and Golf Variant

Connection on fuse carrier **2** (instrument panel at upper left). Remove red/yellow (rt/ge) 4² wire **1** on fuse output of fan SC 22 or SC40 (depending on respective vehicle equipment).



Connection to fuse carrier

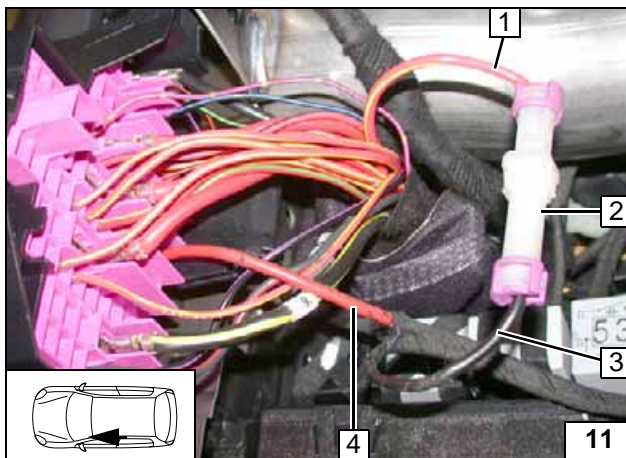

Red (rt) wire from K3/87a **4** with crimped-on standard power timer engaged in fuse output SC22 or SC40. Produce connections as shown in wiring diagram.



Connecting wires

- 1** Red/yellow (rt/ge) wire of fuse SC22 or SC40
- 2** AMP housing
- 3** Black (sw) wire to K3/30

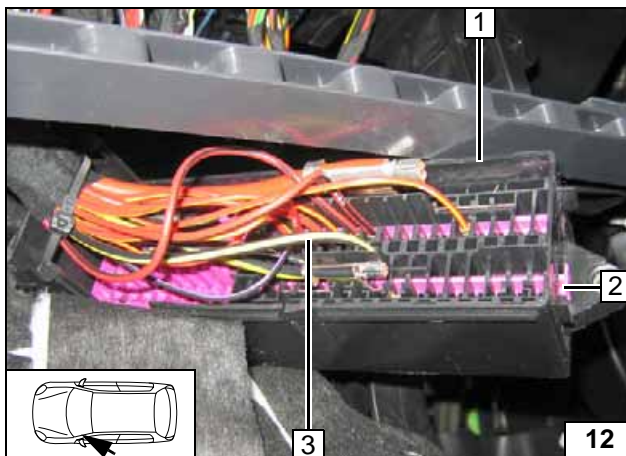

Golf Plus

Fuse socket dependent on vehicle equipment SC33 or SC 35; wire colour black (sw) or black/yellow (sw/ge)
Detach original vehicle fuse carrier **1** (instrument panel at lower left) and unlock contact lock **2**.
Uncrimp 4² black (sw) or black/yellow (sw/ge) wire **3** on fuse output SC33 or SC35



Uncrimping wire

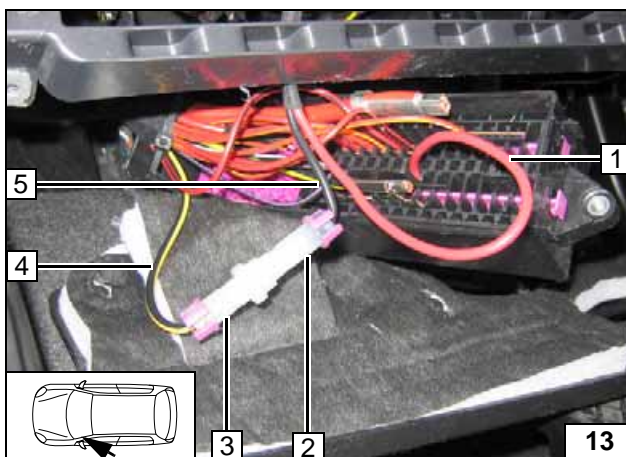

Produce connections as shown in wiring diagram.



Connecting wires

- 1** Red (rt) wire from K3/87a with crimped-on standard power timer engaged in fuse output SC33 or SC35
- 2** AMP housing
- 3** AMP housing
- 4** Black/yellow (sw/ge) wire with original standard power timer
- 5** Black (sw) wire K3/30 with crimped-on tab connector

Lock contact lock again.



Climatronic fan control

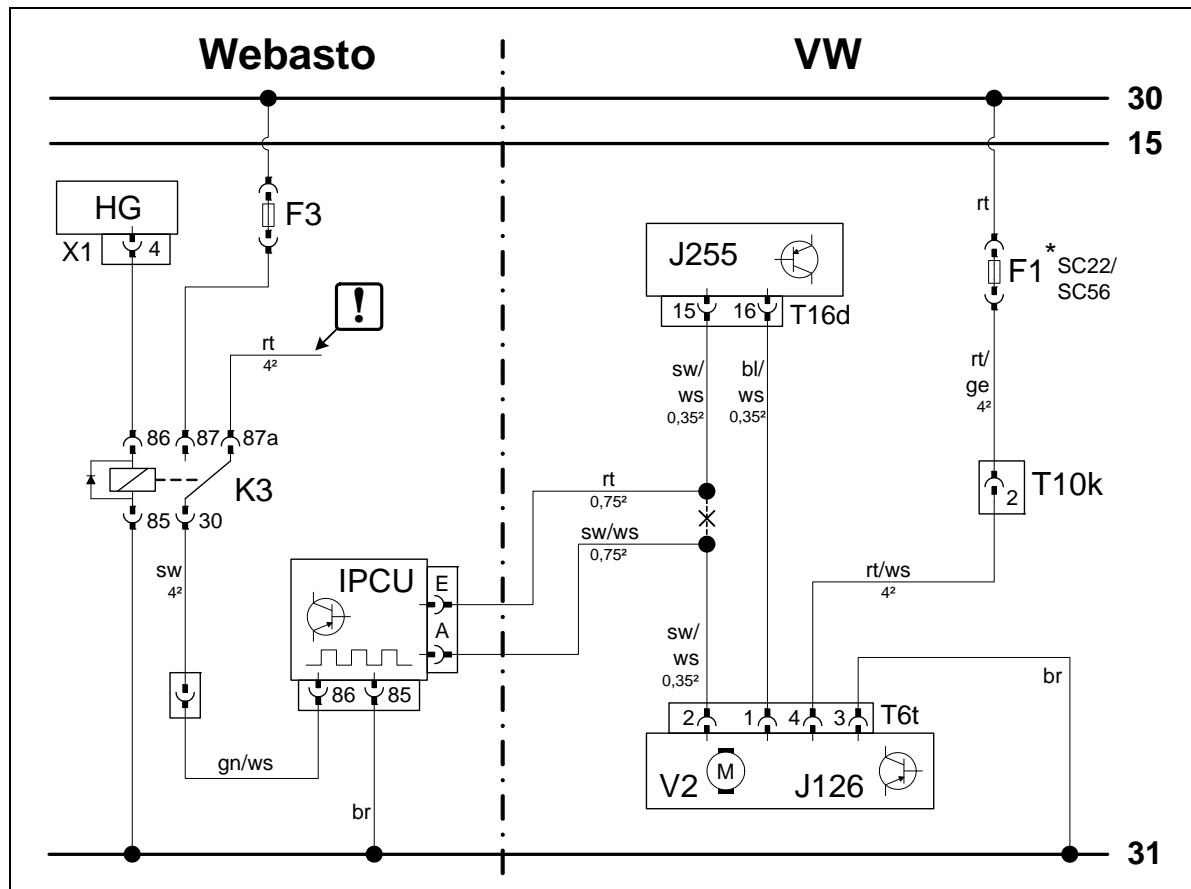

Climatronic wiring diagram

| Webasto components | | Vehicle components | | Colours and symbols | |
|--------------------------------|---------------------------------|--------------------|--|--------------------------|---------------------------------|
| HG | Heater TT-C/P/E | F1* | Fuse 40A (depending on respective fuse assignment) of SC22 or SC56 | rt | red |
| X1 | 6-pin heater connector | T10k | Plug connections | ws | white |
| K3 | Fan relay | J255 | Climatronic control unit | sw | black |
| F3 | Replace 25 A fuse with 3 A fuse | T16d | 16-pin connector J255 | br | brown |
| IPCU | Pulse width modulator | V2 | Fan motor | gn | green |
| IPCU adjustment values: | | T6t | 6-pin connector J126 | ge | yellow |
| Duty cycle: 30% | | | | bl | blue |
| Frequency: 400Hz | | | | ! | Insulate wire end and tie back. |
| Voltage: 8V | | | | X | Cutting point |
| Function: High side | | | | Wiring colours may vary. | |

Legend

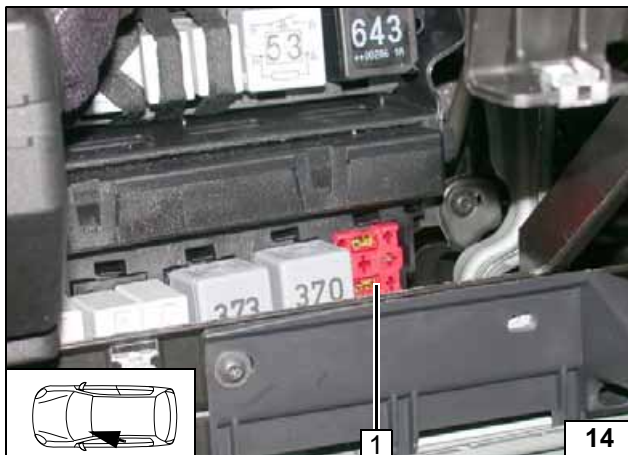

Golf and Golf Variant

Produce connections as shown in wiring diagram. Position of free sockets dependent on vehicle equipment.

1 IPCU socket



Installing IPCU socket

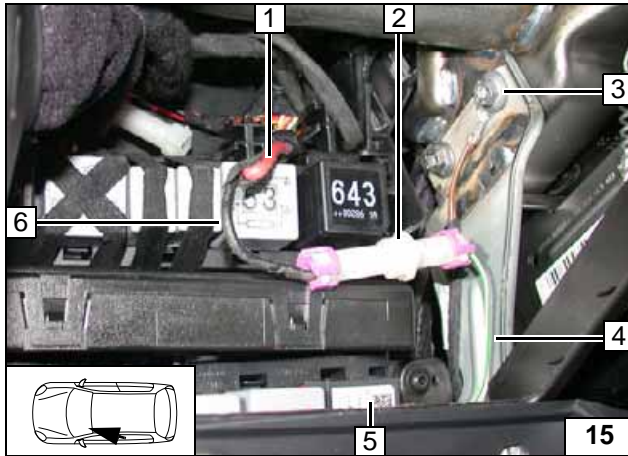
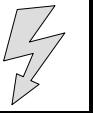

Insulate red (rt) wire K3/87a 1 and tie back. Produce connections as shown in wiring diagram.

- 2 AMP connector
- 3 Brown (br) wire of IPCU/85, original vehicle earth support point
- 4 Green/white (gn/ws) wire of IPCU/86
- 5 IPCU mounted
- 6 Black (sw) wire from K3/30



Connecting IPCU

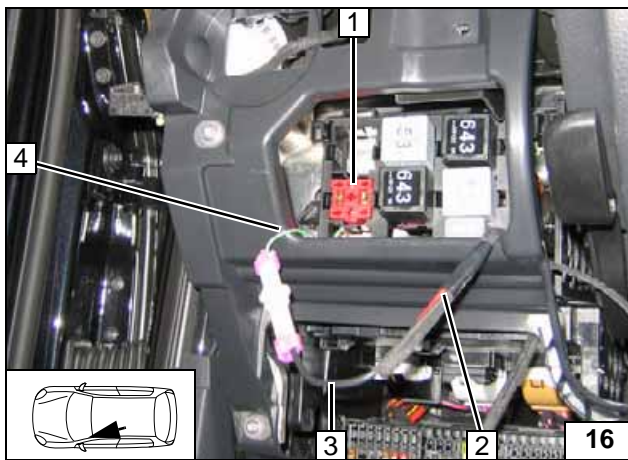

Golf Plus

Insulate red (rt) wire K3/87a 2 and tie back. Position of free sockets depends on respective vehicle equipment. Produce connections as shown in wiring diagram.

- 1 IPCU socket
- 3 Black (sw) wire from K3/30
- 4 Green/white (gn/ws) IPCU/86



Installing wiring harness of Climatronic

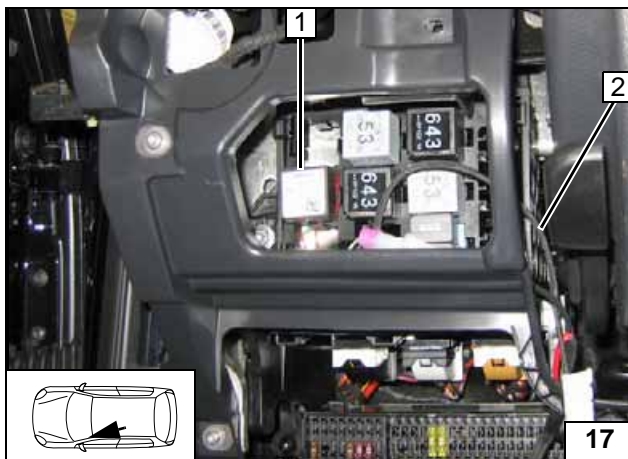

Brown (br) wire from IPCU/85 to original vehicle earth point.

- 1 IPCU mounted
- 2 Wiring harness of IPCU



Connecting wires

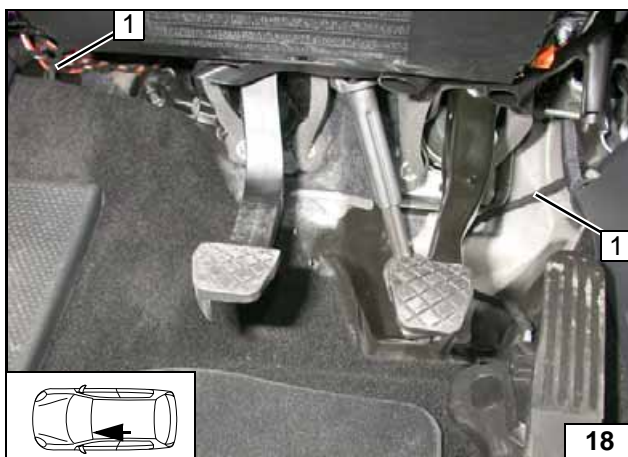

All vehicles

Route wiring harness of IPCU 1 to centre console.



Routing wiring harness from IPCU

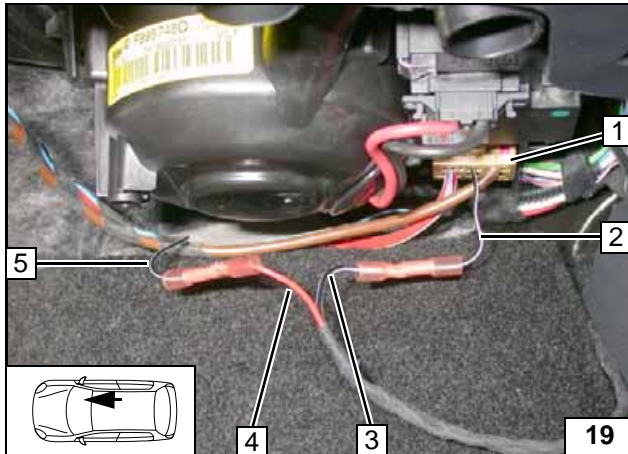
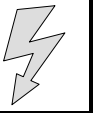

Route wiring harness of IPCU 1 to fan unit. Connection on connector of fan unit 1.

- 2 Black/white (sw/ws) wire of connector T6t/2
- 3 Black/white (sw/ws) wire of IPCU/A
- 4 Red (rt) wire of IPCU/E
- 5 Black/white (sw/ws) wire of A/C control panel



**Connect-
ing fan unit**

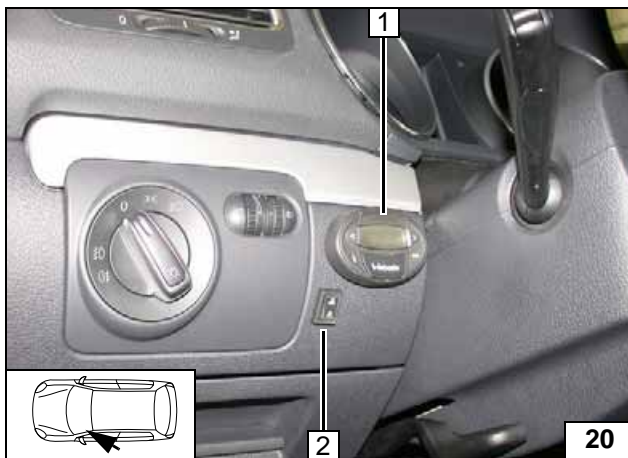

Digital timer, summer/winter switch option

Golf and Golf Variant

- 1 Digital timer
- 2 12 mm dia. hole; summer/winter switch



Digital timer

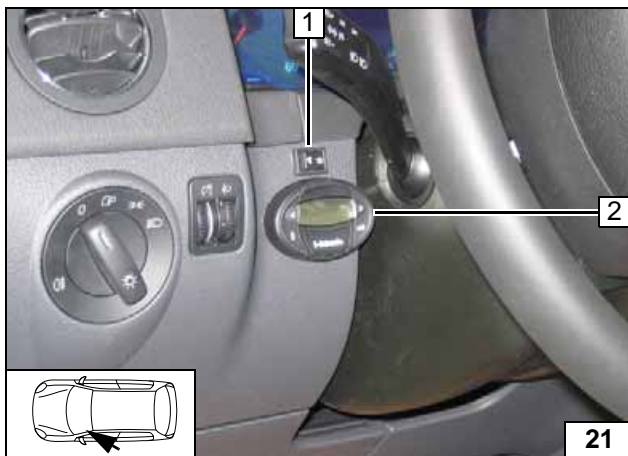

Golf Plus

- 1 Summer/winter switch
- 2 Digital timer



Digital timer

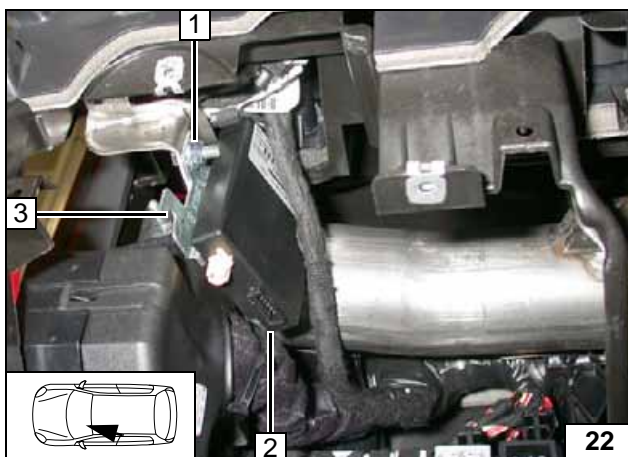

Remote option (Telestart)

Golf and Golf Variant

Drill out bracket 3 to 6.5 mm dia. at position 1.

- 1 Existing hole, M6x20 bolt, flanged nut
- 2 Receiver



Installing receiver

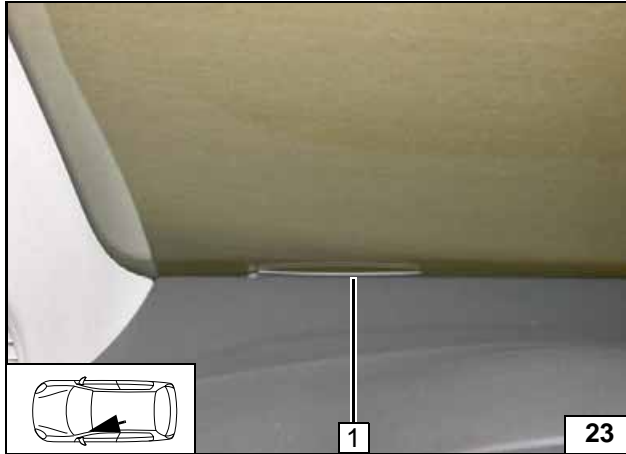
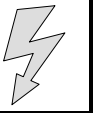

1 Antenna



Installing antenna

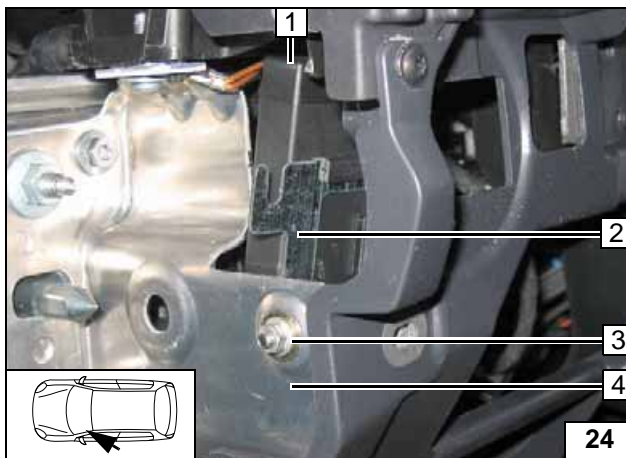

Golf Plus

Bend down lower tab of bracket by 90° and drill out hole to 6.5 mm dia. as shown.

- 1 Receiver
- 2 Bracket
- 3 M6 bolt, large diameter washer (between bracket instrument carrier), large diameter washer (from outside), flanged nut
- 4 Instrument carrier, existing hole



Installing receiver

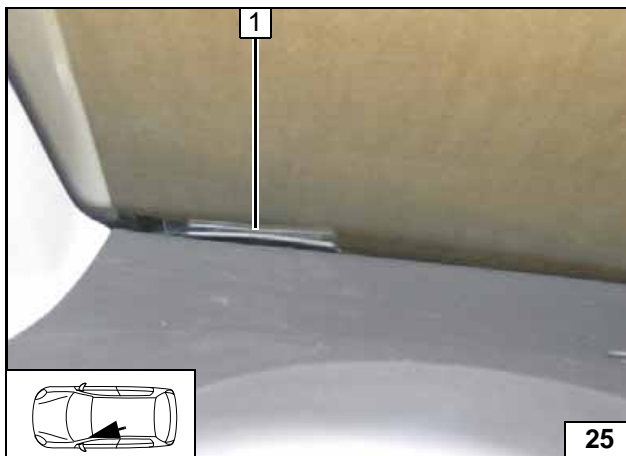

1 Antenna



Installing antenna

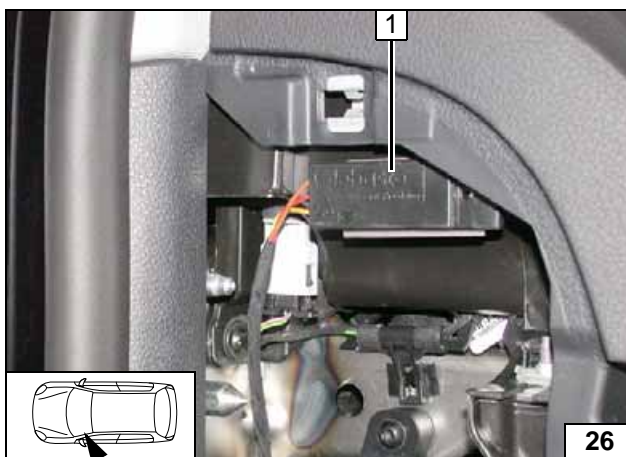

Temperature sensor T100 HTM

Figure shows Golf VI. Fasten temperature sensor 1 with double-sided adhesive tape.



Installing temperature sensor

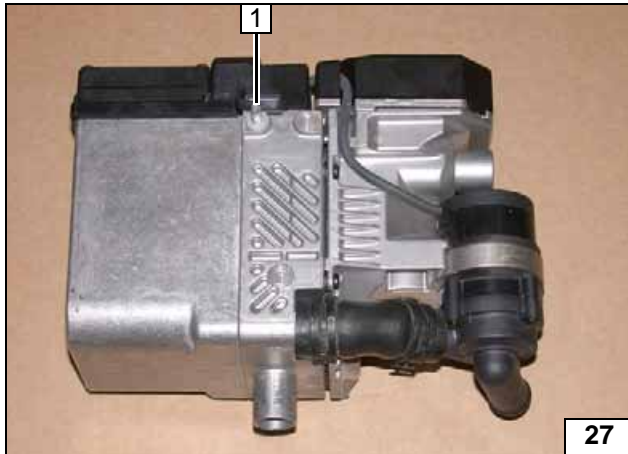
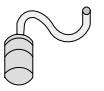

Premounting heater

- 1 Ejet stud

Premounting heater

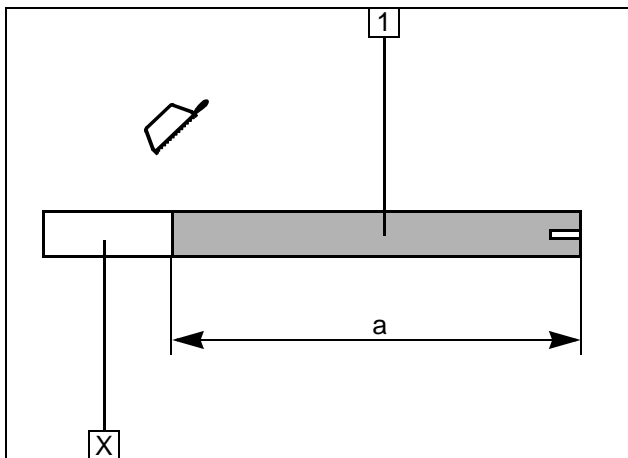

- 1 Combustion air pipe
a = 250

Discard section X

Cutting combustion air pipe to length

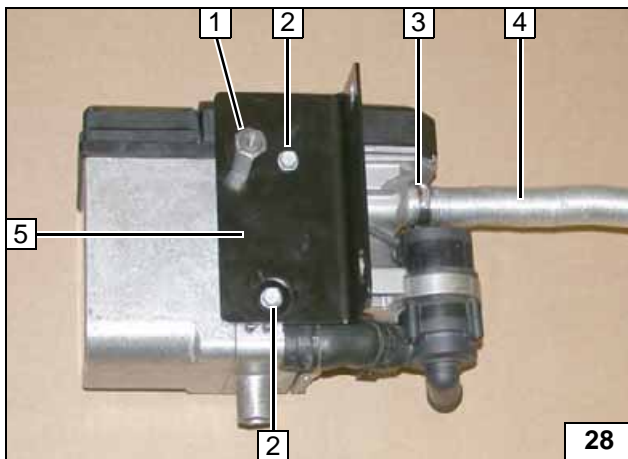

Insert one washer each between heater and bracket at positions 2.

- 1 M6x30 spacer nut
- 2 Ejet screw, washer [2x each]
- 3 27 mm dia. hose clamp
- 4 Combustion air pipe
- 5 Bracket



Premounting heater

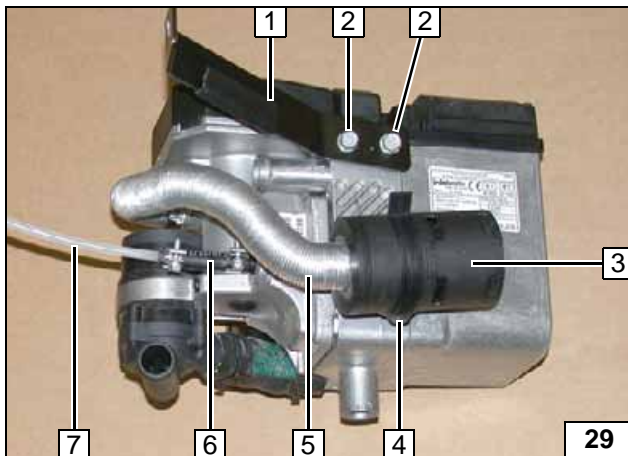

- 1 Strut
- 2 Ejet screw [2x]
- 3 Silencer
- 4 Retaining clip in hole
- 5 Combustion air pipe
- 6 Hose section, 10 mm dia. hose clamp [2x]
- 7 Fuel line

Premounting heater

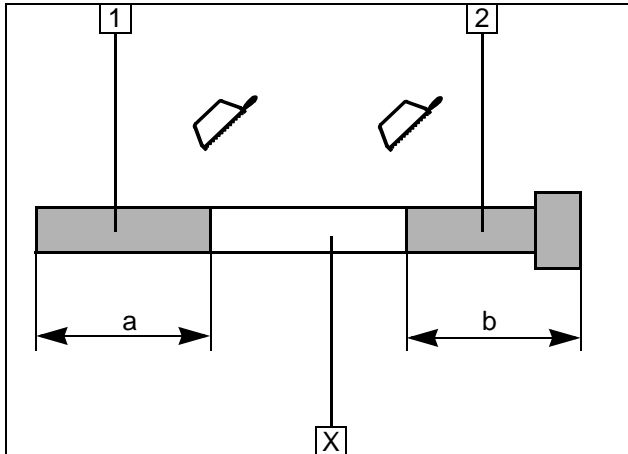
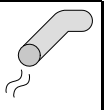

Preparing exhaust system

- 1 Exhaust pipe
a = 190
- 2 Exhaust end section
b = 240

Discard section X



**Cutting ex-
haust pipe
to size**

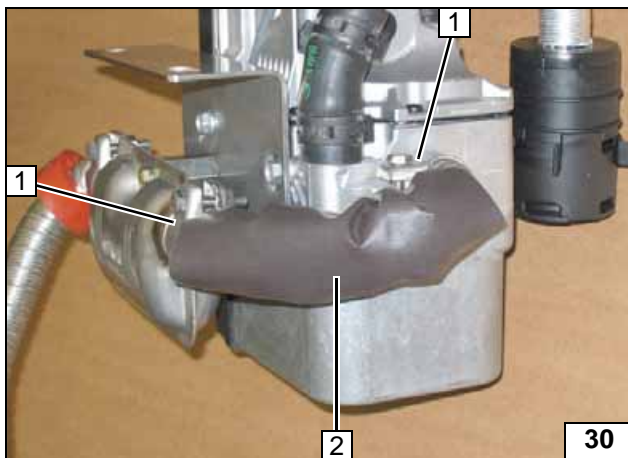

Slide insulation 2 onto exhaust pipe.

- 1 Hose clamp [2x]



**Premount-
ing ex-
haust pipe**

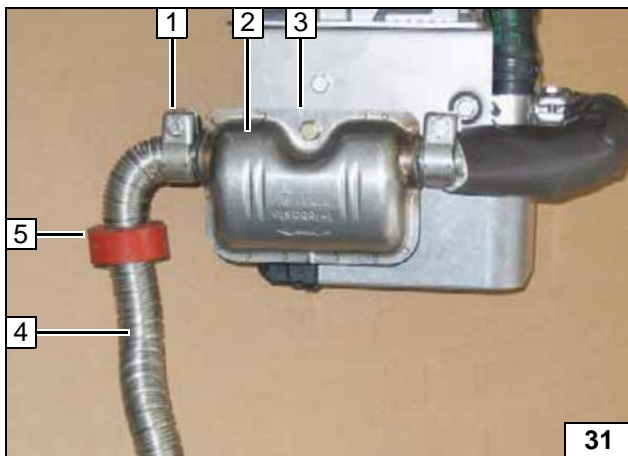

- 1 Hose clamp
- 2 Silencer
- 3 M6x16 bolt, spring lockwasher on spacer nut
- 4 Exhaust end section
- 5 Red (rt) protective rubber isolator

**Premount-
ing silenc-
er and
exhaust
end sec-
tion**



- 1 Exhaust end section

**Aligning
exhaust
end sec-
tion**

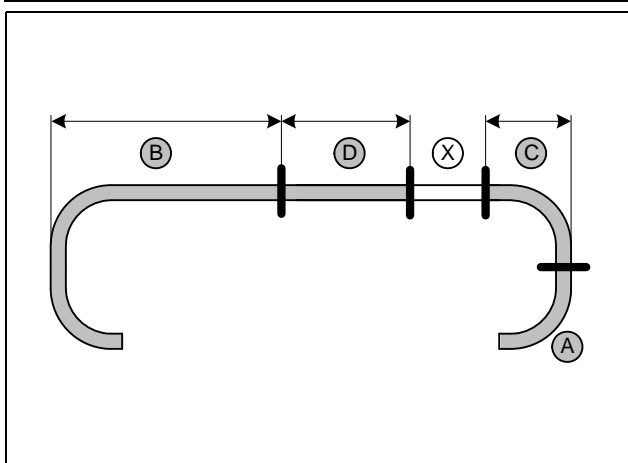
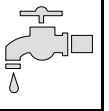

Preparing coolant circuit

1.6 TDI only

Discard section X

- B = 840
- C = 100
- D = 720

Cutting hoses to length

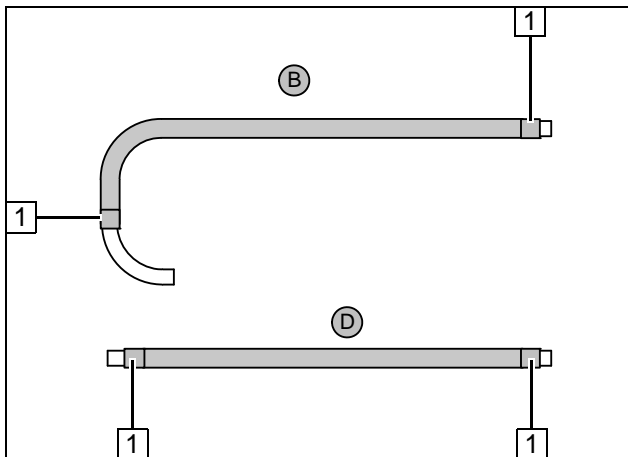

Push braided protection hoses onto hose A and C and cut to length.
Cut heat shrink plastic tubing to length.

- 1 25 mm long heat shrink plastic tubing [4x]

Preparing coolant hoses

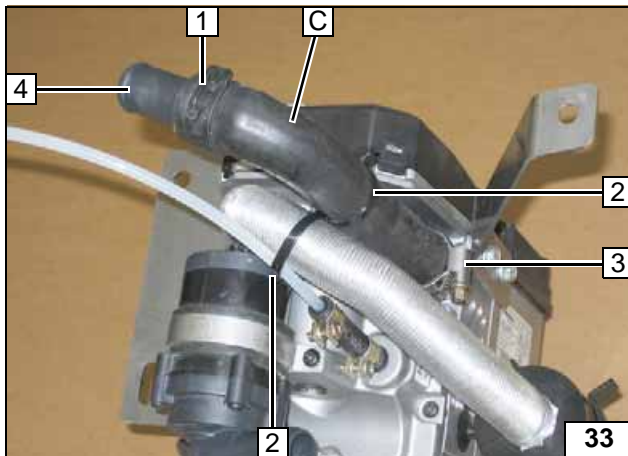

- 1 27 mm dia. spring clip
- 2 Cable tie [2x]
- 3 27 mm dia. hose clamp
- 4 20x20 connecting pipe

Installing hose C

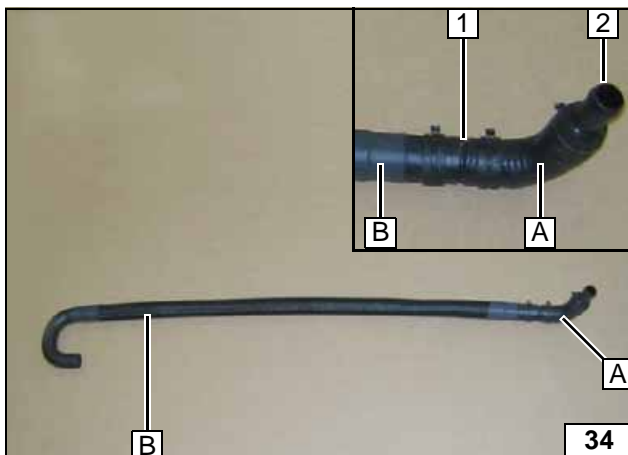

- 1 20x20 mm connecting pipe, 27 mm dia. spring clip [2x]
- 2 18x20 connecting pipe, 27mm dia. spring clip

Preparing hose A and B

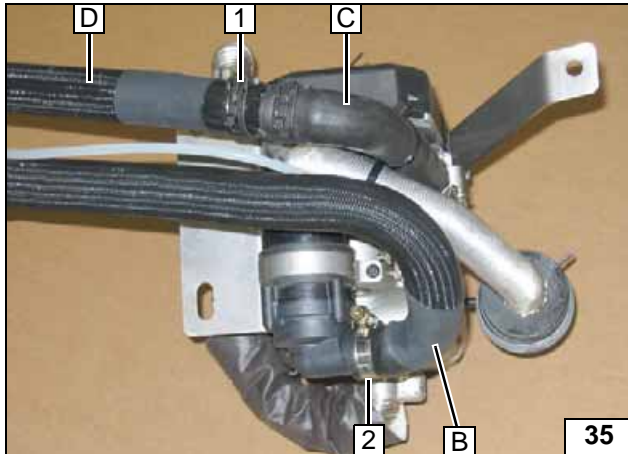
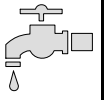

- 1 27 mm dia. spring clip
- 2 27 mm dia. hose clamp

Premounting hoses

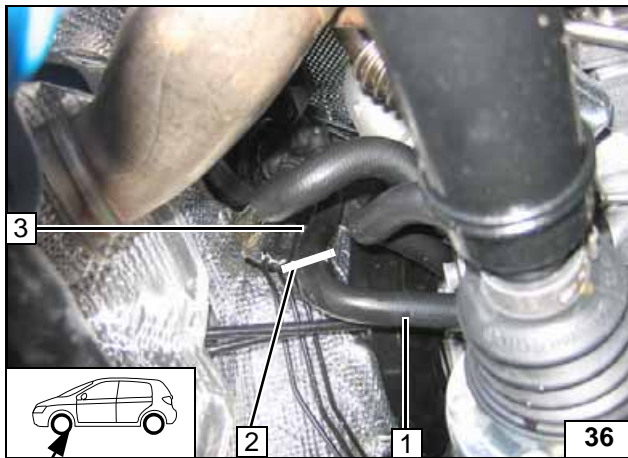

Remove hose from heat exchanger inlet 3.

- 1 Engine outlet
- 2 Cutting point

Cutting point



After pre-installing hose, re-install heat exchanger inlet in vehicle.

- 2 Black (sw) protective rubber profile.
- 3 25 mm dia. spring clip
- 4 18x20 connecting pipe

Premounting hose on heat exchanger inlet

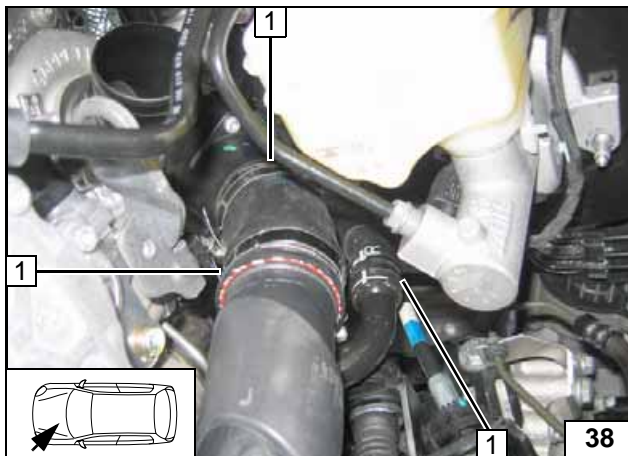

Align original vehicle hose clamps 1 [3x] as shown.

Aligning clamps

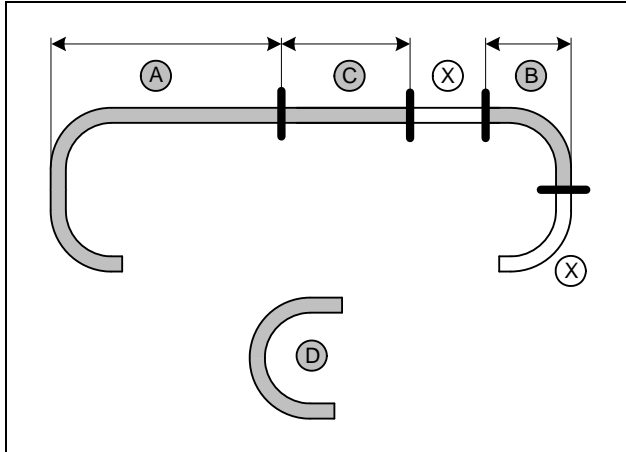
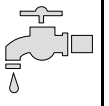

2,0 TDI only

Hose **D** = 180° elbow
Discard section **X**

A = 920
B = 100
C = 910



Cutting hoses to length

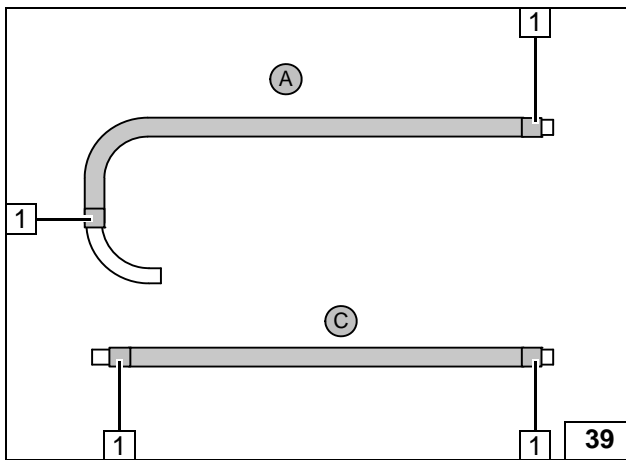

Push braided protection hoses onto hose **A** and **C** and cut to length.
Cut heat shrink plastic tubing to length.

1 25 mm long heat shrink plastic tubing [4x]



Preparing coolant hoses

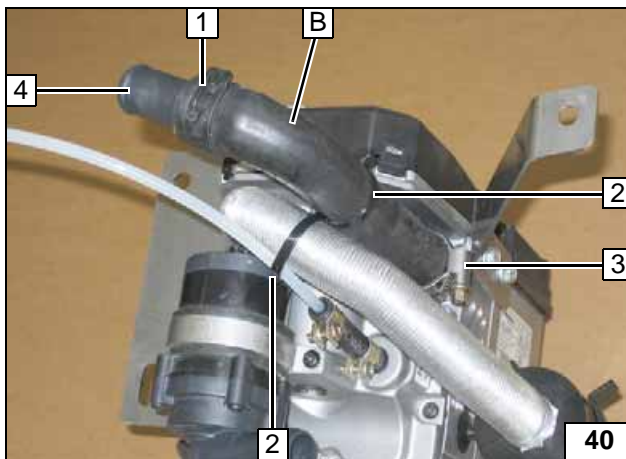

- 1** 27 mm dia. spring clip
- 2** Cable tie [2x]
- 3** 27 mm dia. hose clamp
- 4** 20x20 connecting pipe

Installing hose B

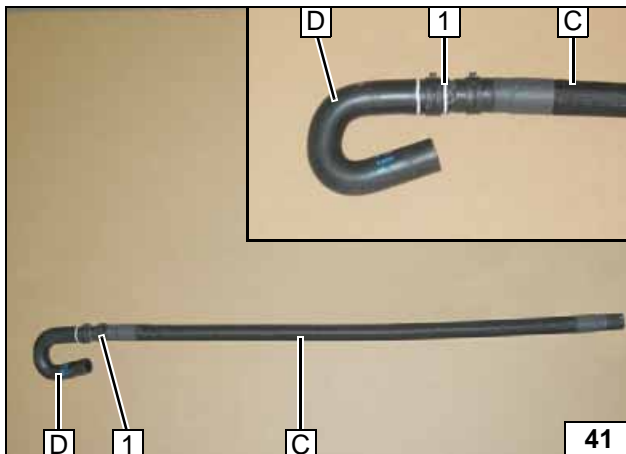

1 20x20 mm connecting pipe, 27 mm dia. spring clip [2x]

Preparing hose C and D

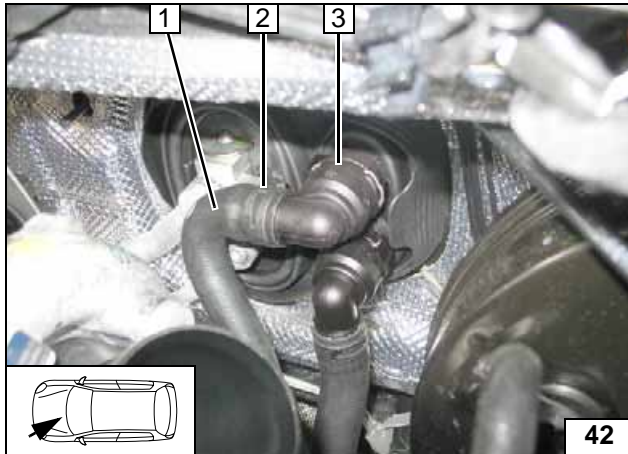
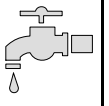

Pull hose off engine outlet 1. Spring clip 2 will be reused.
Remove coupling from heat exchanger inlet 3.



Cutting point

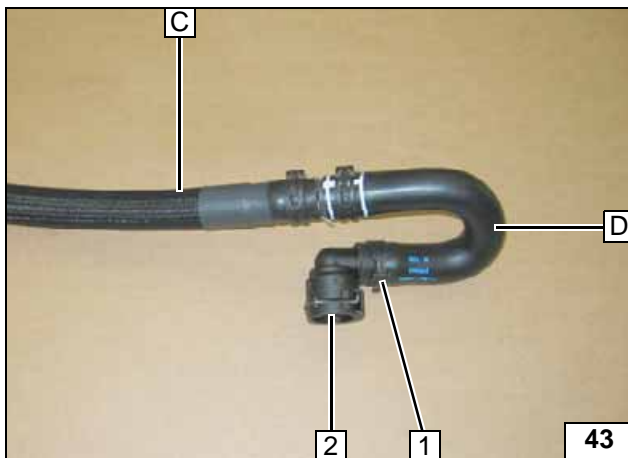

1 Original vehicle spring clip
2 Coupling of heat exchanger inlet

Premounting hose C and D

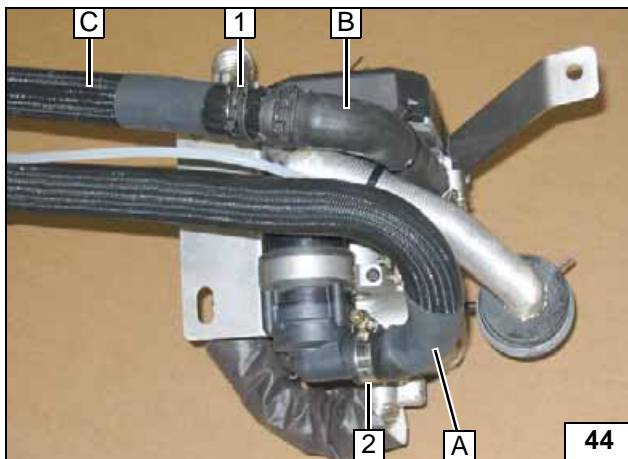

1 27 mm dia. spring clip
2 27 mm dia. hose clamp

Premounting hoses

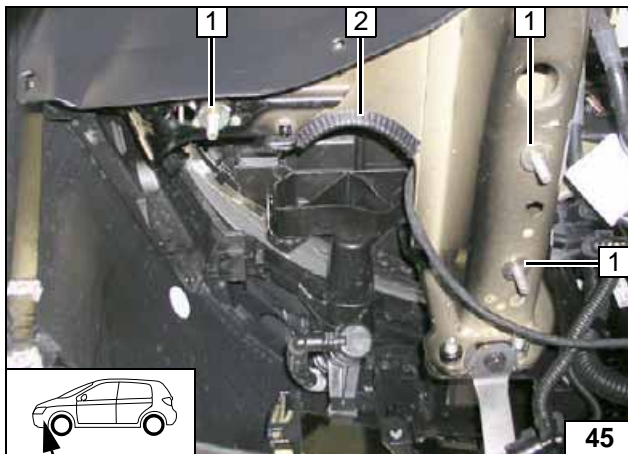

Preparing installation location

Prevent large diameter washer from falling by securing with putty etc.

1 Large diameter washer on original vehicle stud bolt [3x]
2 100 mm edge protection



Preparing installation location

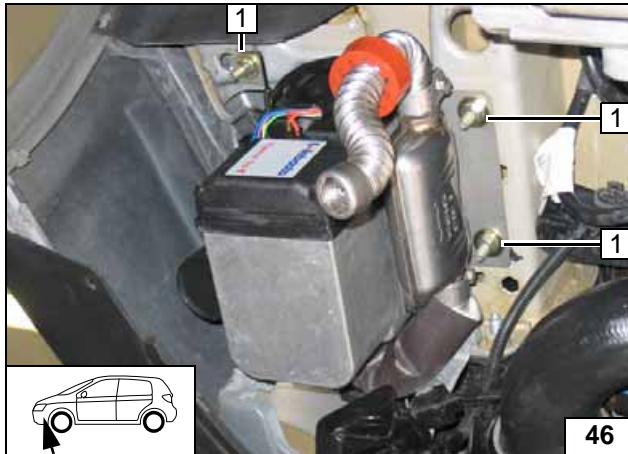
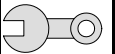

Installing heater

- 1 Large diameter washer, flanged nut M8 [3x]



Installing heater

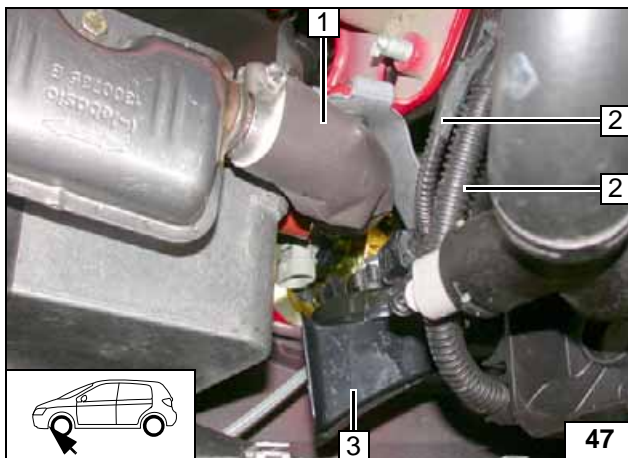

Ensure freedom of movement of exhaust system in relation to original vehicle components and lines.

- 1 Exhaust pipe
- 2 Original vehicle wiring harnesses (secured with cable ties)
- 3 Horn



Aligning exhaust system



Punch through perforation of heater cover at position 2. Mount clip cable tie and fasten wiring harness of heater 1.



Connecting wiring harness

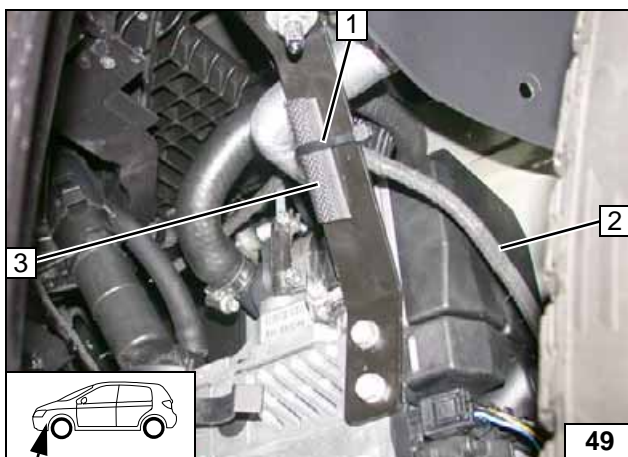

Combustion air silencer tied back for demonstration purposes.

- 1 Cable tie
- 2 Wiring harness of heater
- 3 50 mm edge protection



Fastening wiring harness

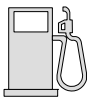

Fuel

CAUTION!

Open the vehicle's fuel tank cap, ventilate the tank and then re-close the tank lock.

Catch any fuel running off in an appropriate container.

Install fuel line and metering pump wiring harness so that they are protected against stone impact. Unless specified otherwise, always fasten using cable ties. Mount the fuel line and wiring harness with rub protection on sharp edges.

WARNING!

The fuel line and wiring harness are routed to the metering pump as shown in the wiring harness routing diagram.

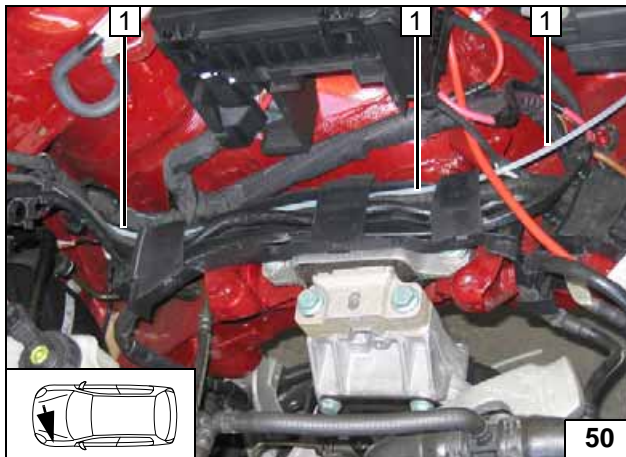

1 Fuel line

Installing fuel line

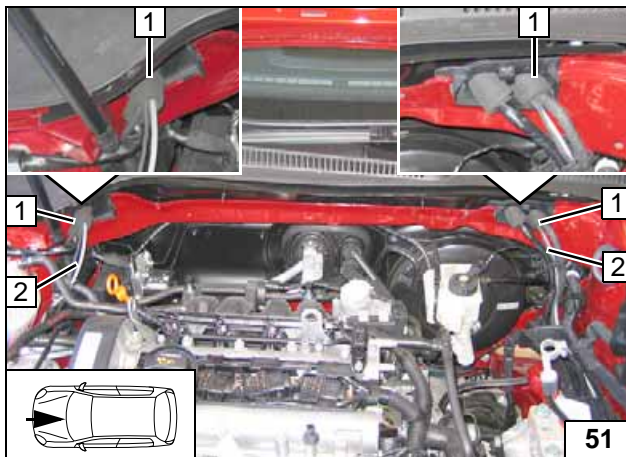

Route fuel line and wiring harness of metering pump **2** in coolant reservoir to right and fasten on original vehicle lines with cable ties. Pay particular attention to freedom of movement of wiper linkage. Route fuel line and wiring harness of metering pump to underbody in wiring duct.

1 Existing pass through [2x]



Installing lines

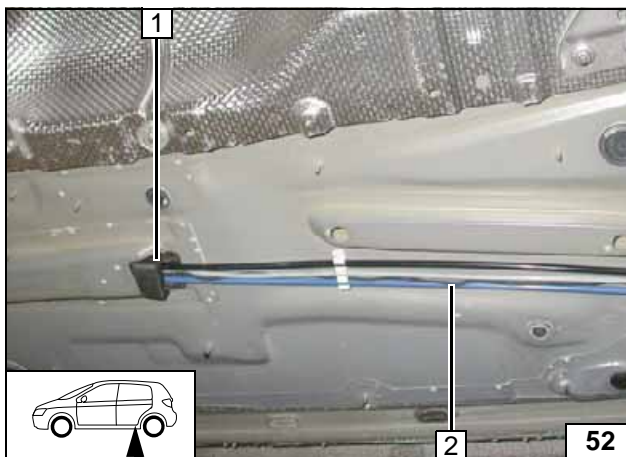

Route fuel line and wiring harness of metering pump along original vehicle fuel lines **2** to fuel tank.

1 Line duct



Installing lines

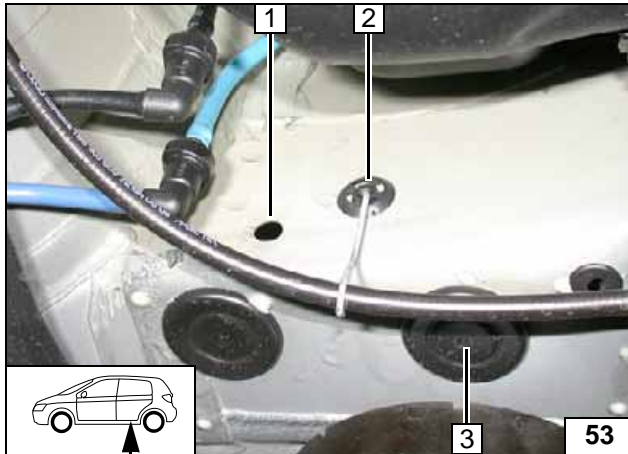

Remove sealing plug **3** for installation. Remove bracket of handbrake cable at position **2** and install at position **1**.



Offsetting bracket

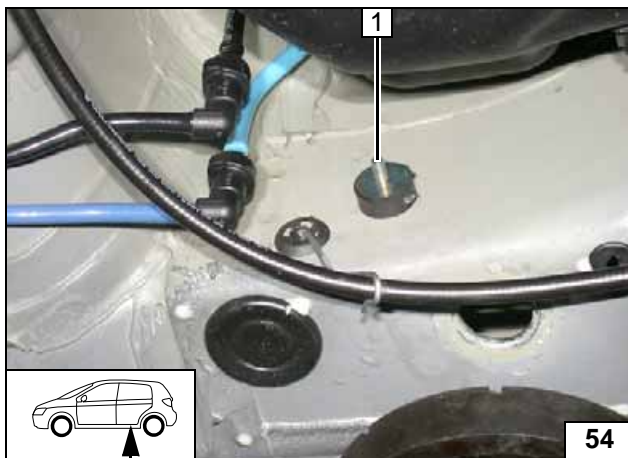

1 Silent block, large diameter washer, flanged nut

Installing silent block

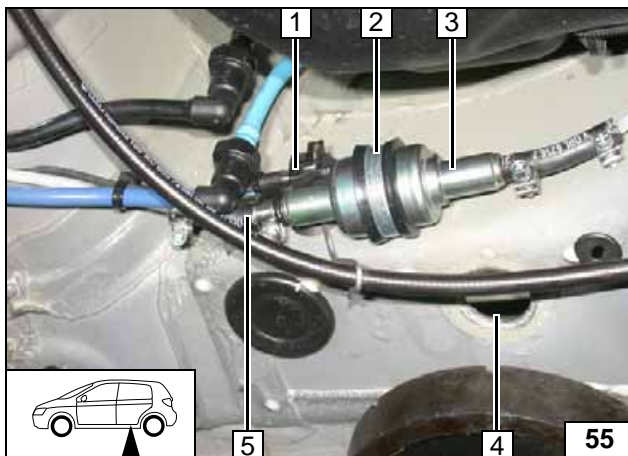

Following installation, remount sealing plug at position **4**.



- 1** Wiring harness of metering pump, connector mounted
- 2** Rubber-coated p-clamp, flanged nut, silent block
- 3** Metering pump
- 5** Fuel line, hose section, 10 mm dia. hose clamp [2x]

Installing metering pump

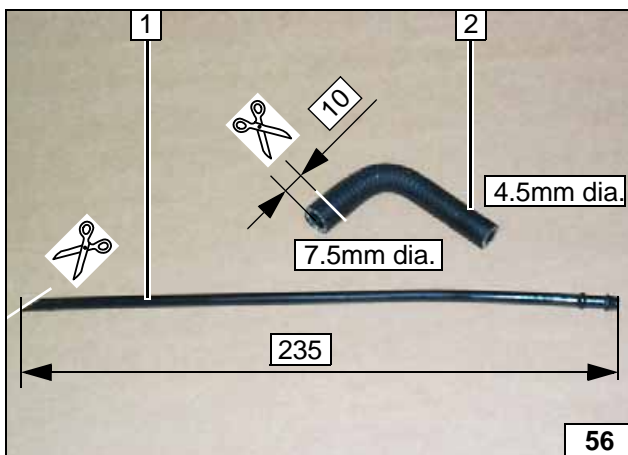

- 1** Standpipe
- 2** Moulded hose

Cutting standpipe and moulded hose to size

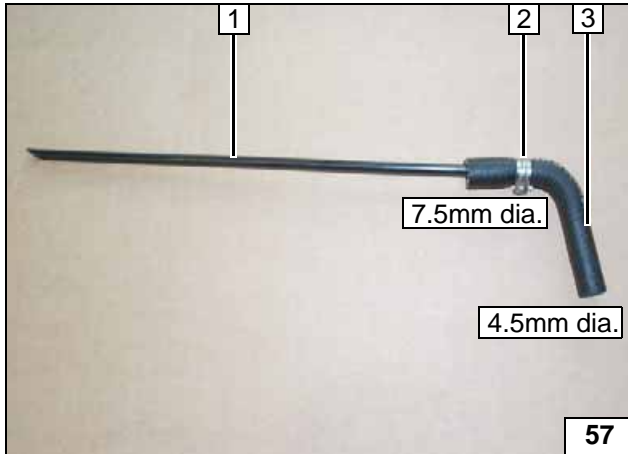

10 mm dia. Caillau clamp **2** in centre between beads on end of standpipe.

- 1 Standpipe
- 3 Moulded hose



Premounting standpipe and moulded hose

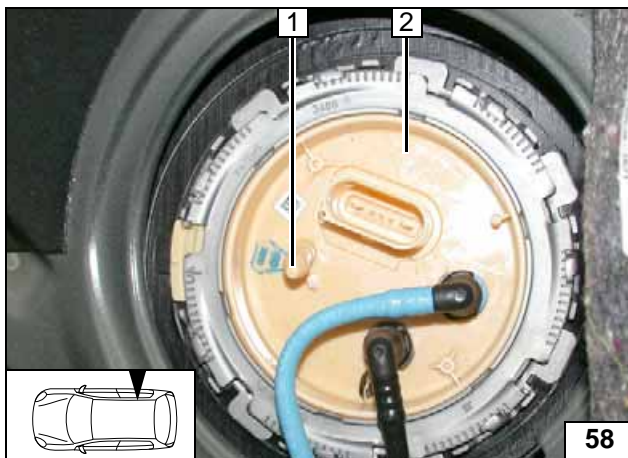

Cut 3 mm off blind plug **1**.

- 2 Fuel-tank sending unit



Cutting off blind plug

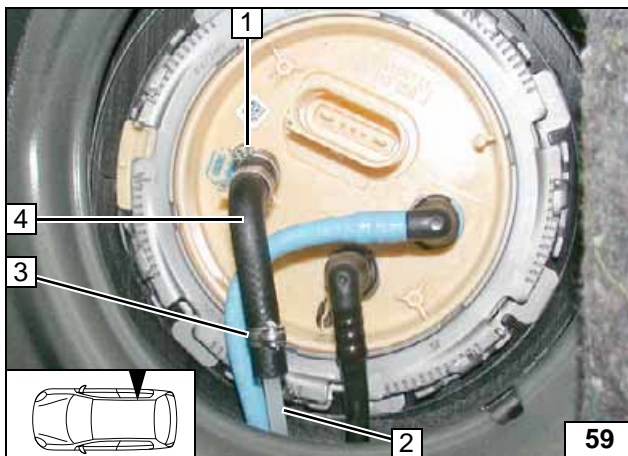

Ensure sufficient distance from adjacent components, especially from fuel gauge.

- 1 13.5mm dia. Caillau clamp
- 2 Fuel line
- 3 10 mm dia. Caillau clamp
- 4 Moulded hose with standpipe



Connecting fuel-tank sending unit

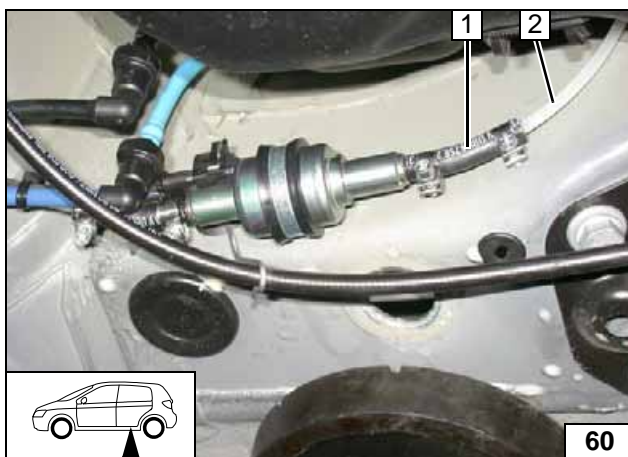

- 1 Hose section, 10mm dia. hose clamp [2x]
- 2 Fuel line

Connecting metering pump

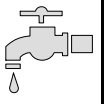

Coolant circuit 1.6 TDI





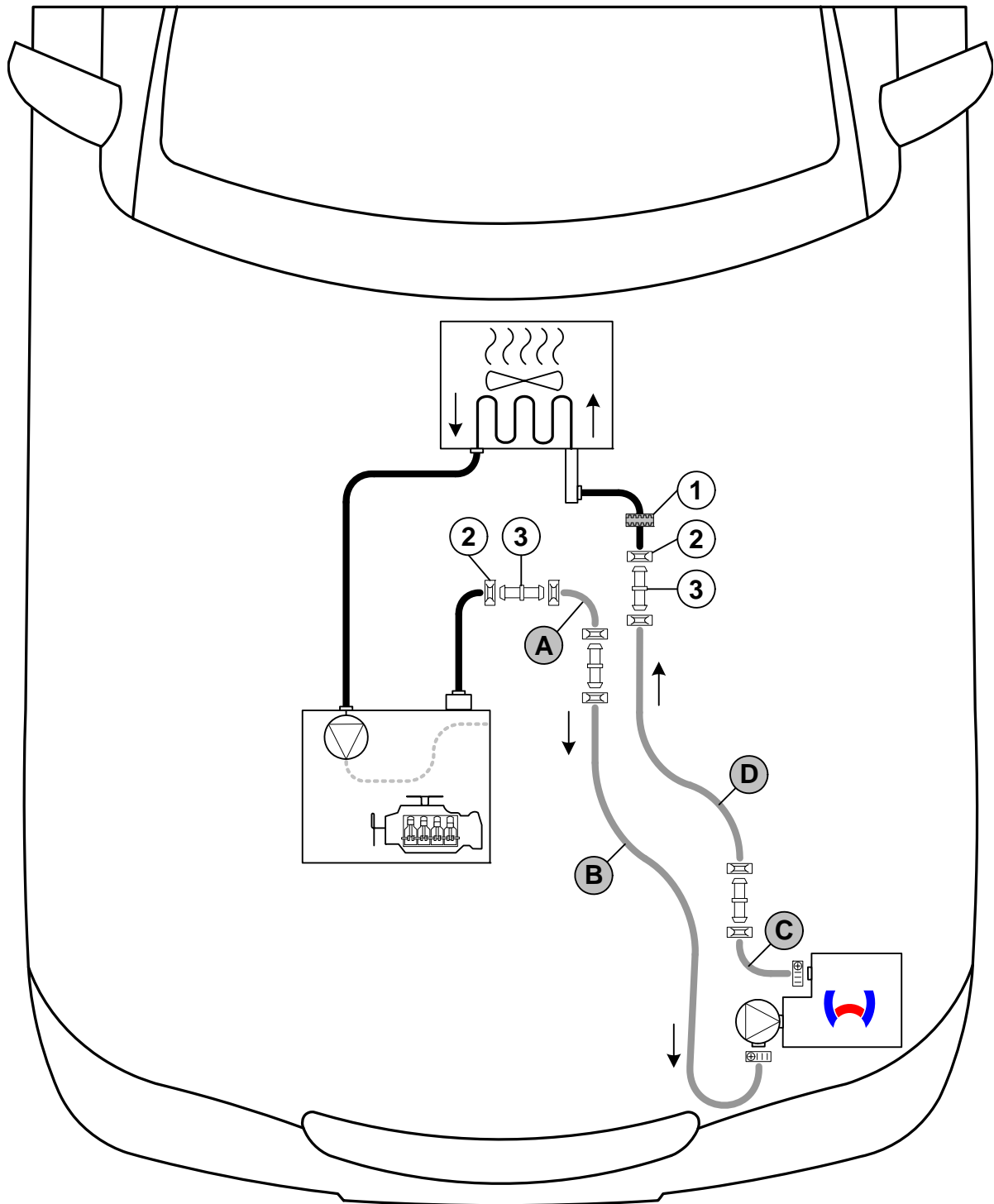

WARNING!

Any coolant running off should be collected in an appropriate container. Install hoses so that they are kink-free. Unless specified otherwise, always fasten using cable ties. Position clamps so that other hoses cannot be damaged. The heater must be filled with coolant when installing the hoses. The connection should be "inline" based on the following diagram:



Hose installation diagram

All spring clips without a specific designation  = 27mm dia. All connecting pipes without a specific designation  = 20x20mm dia. All hose clamps  = 20-27mm dia. **1** = Black (sw) protective rubber isolator. **2** = 25mm dia. spring clip . **3** = 18x20mm dia. connecting pipe .



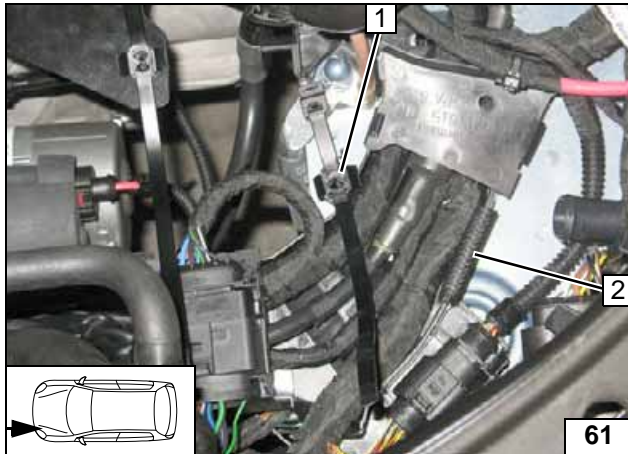

Drill 6mm hole at position 1. When drilling, watch lines located behind. Mount clip-type cable tie 1.

2 50 mm edge protection



Installing clip-type cable tie

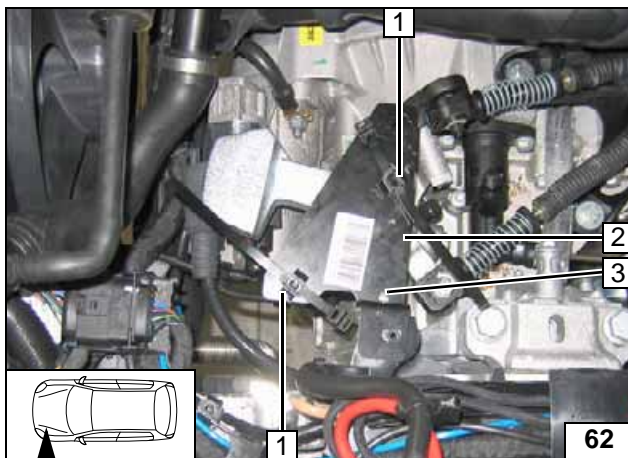

Insert clip-type cable tie 1 [2x] in holes of bracket for coolant hoses 2.

3 M6x20 bolt, flanged nut, existing hole



Installing bracket

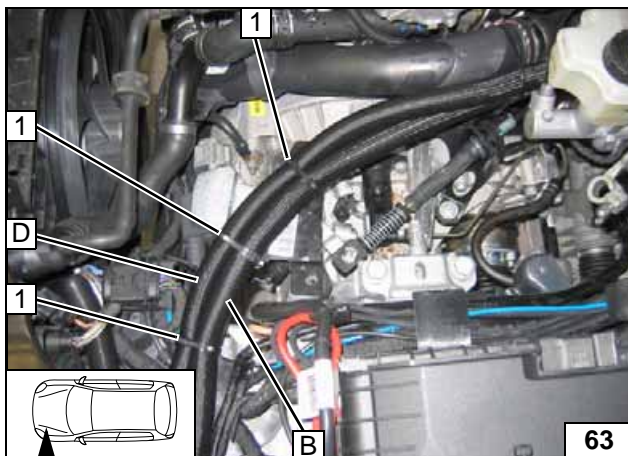

Close clip-type cable tie 1 [3x].



Routing in engine compartment

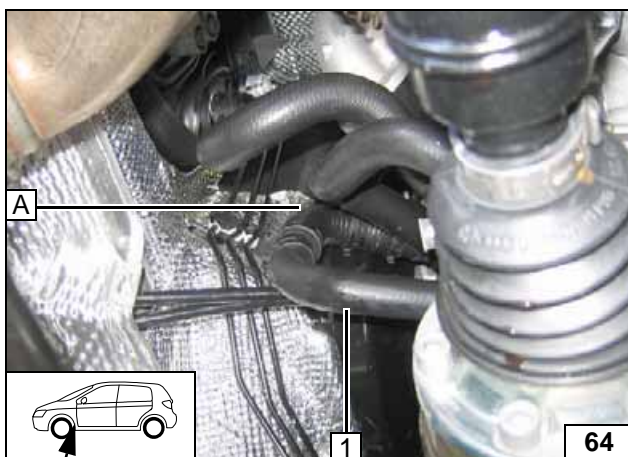

1 Hose of engine outlet

Connecting engine outlet

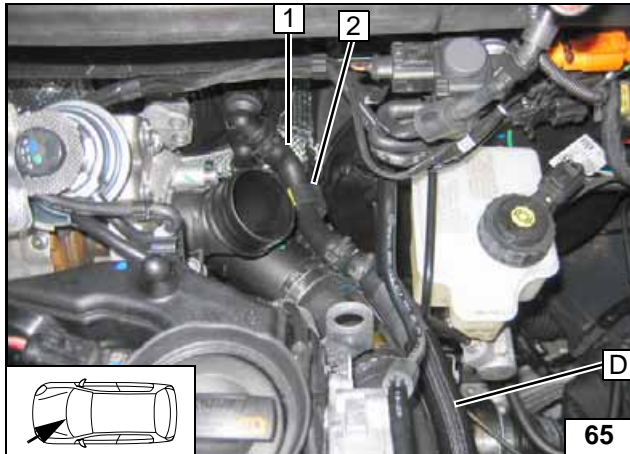

- 1 Hose on heat exchanger inlet
- 2 Position black (sw) rubber isolator

**Connect-
ing heat
exchanger
inlet**



Fix hose **B** and **D** with cable tie **1**.



**Aligning
hoses**

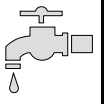

Coolant circuit 2.0 TDI





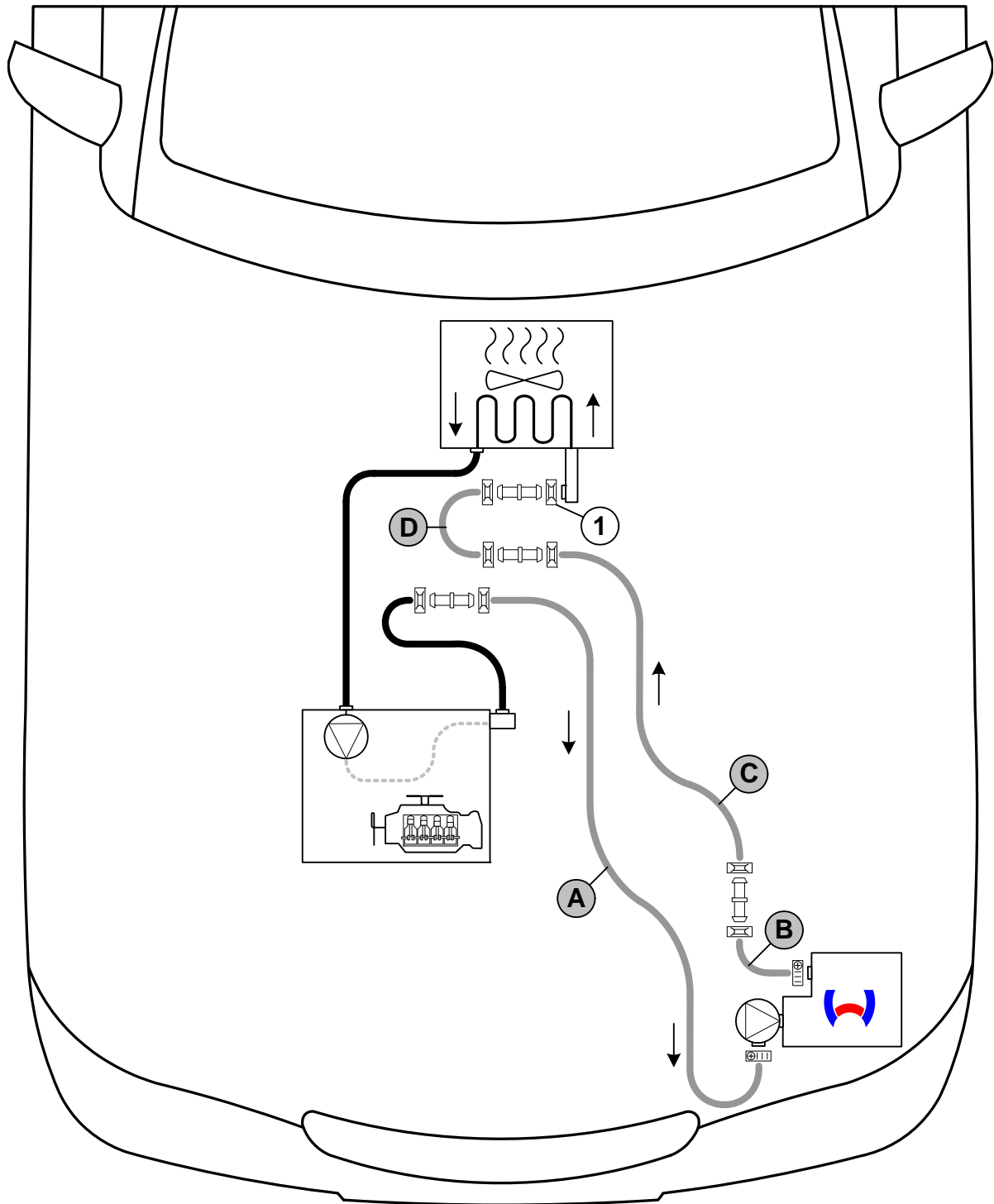

WARNING!

Any coolant running off should be collected in an appropriate container. Install hoses so that they are kink-free. Unless specified otherwise, always fasten using cable ties. Position clamps so that other hoses cannot be damaged. The heater must be filled with coolant when installing the hoses. The connection should be "inline" based on the following diagram:



Hose installation diagram

All spring clips  = 27 mm dia.. 1 = Original vehicle spring clip  .
 All connecting pipes  = dia. 20x20. All hose clamps  = 20-27 mm dia.



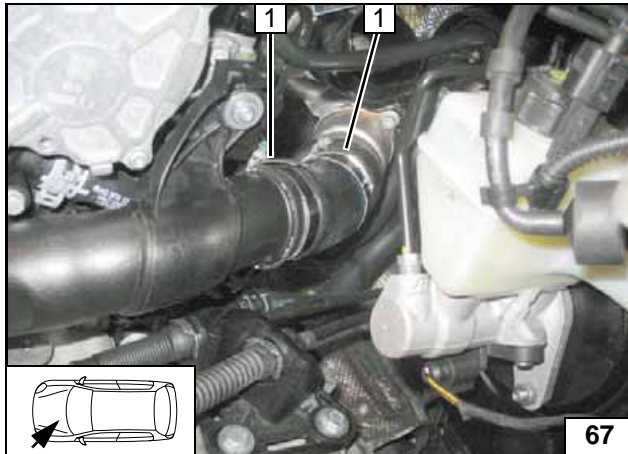
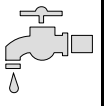

Align original vehicle hose clamps **1** [2x] as shown (turn to right).



Aligning clamps

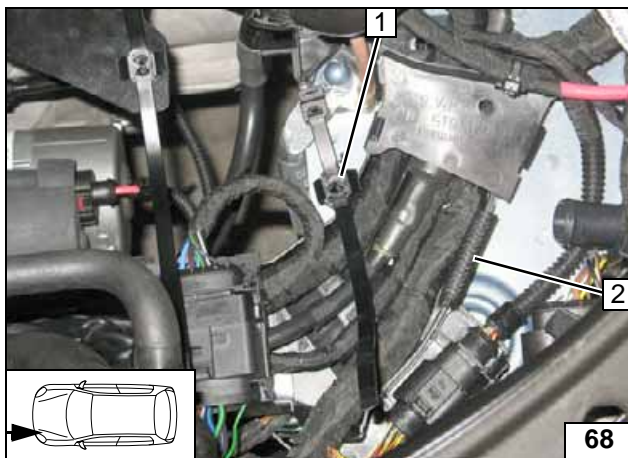

Drill 6mm hole at position **1**. When drilling, watch lines located behind. Mount clip-type cable tie **1**.



2 50 mm edge protection

Installing clip-type cable tie

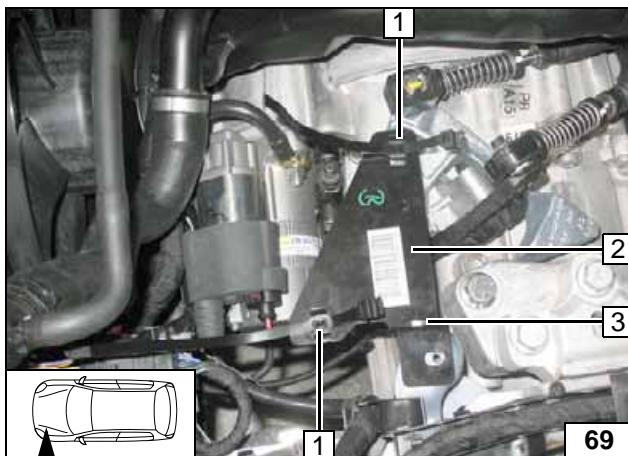

Insert clip-type cable tie **1** [2x] in holes of bracket for coolant hoses **2**.



3 M6x20 bolt, flanged nut, existing hole

Installing bracket

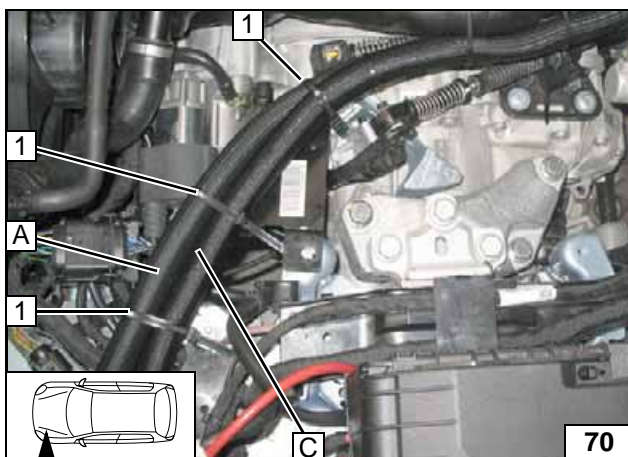

Close clip-type cable tie **1** [3x].



Routing in engine compartment

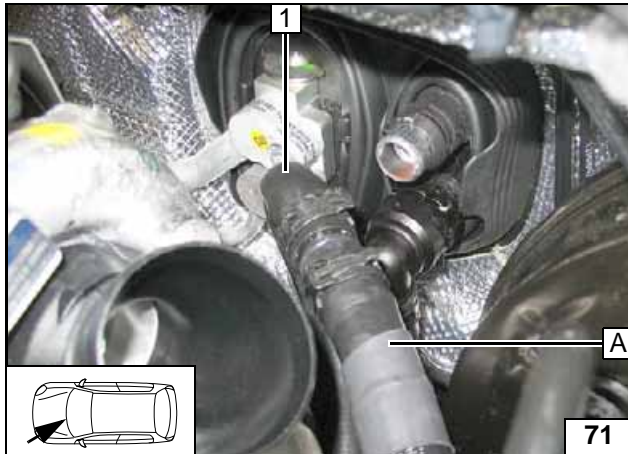
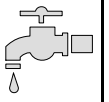

1 Hose of engine outlet

Connect-
ing engine
outlet

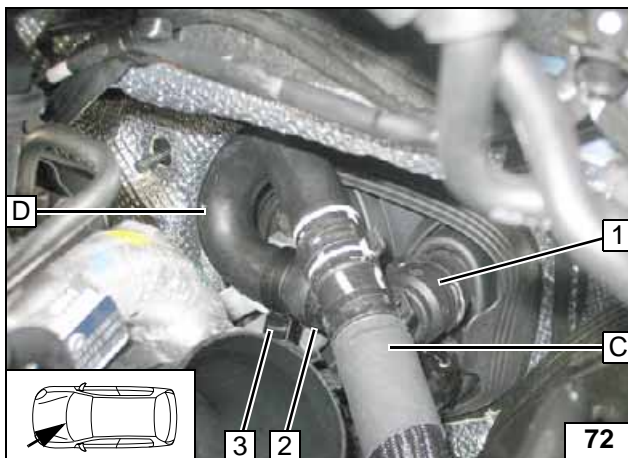

1 90° connection on heat exchanger inlet
2 Original vehicle spring clip
3 Spacer bracket

Connect-
ing heat
exchanger
inlet

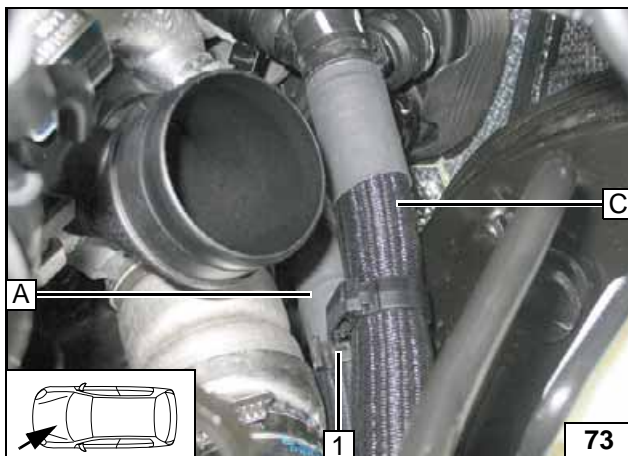

1 Lockable spacer bracket

Install-
ing
spacer
bracket

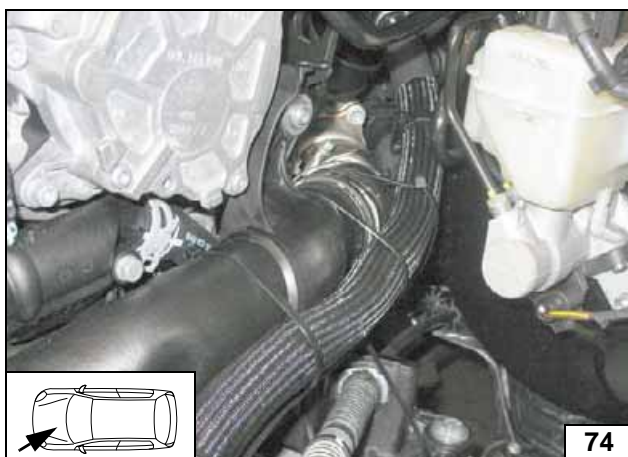

Fix hose **A** and **C** in place with cable tie.



Align-
ing
hoses

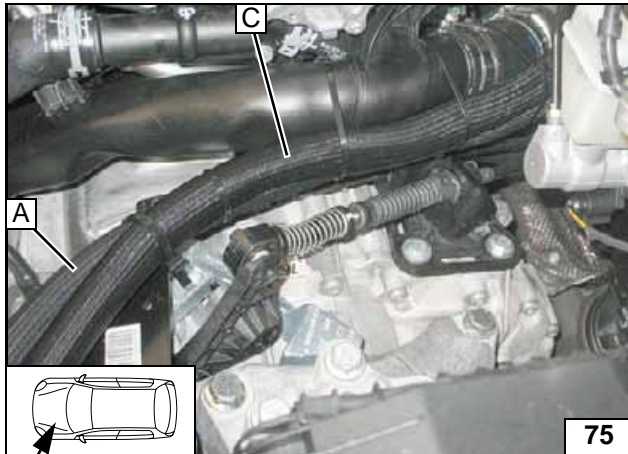
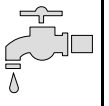

Fix hose **A** and **C** in place with cable tie. Ensure sufficient distance from neighbouring components.



Aligning hoses

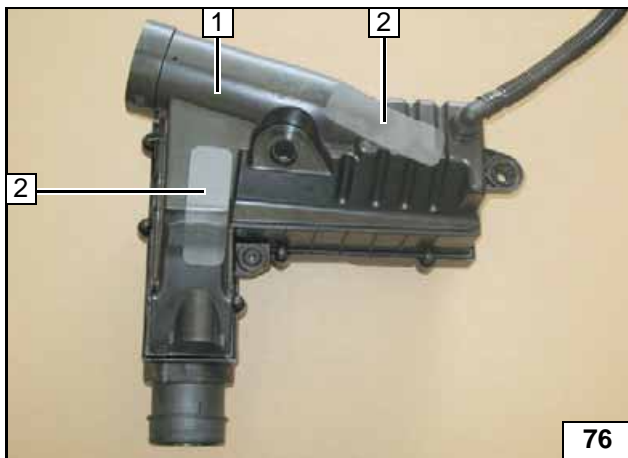

All vehicles

Position of drain pipe may vary. Glue rub protection **2** [2x] onto air filter box **1** as shown.



Preparing air filter box

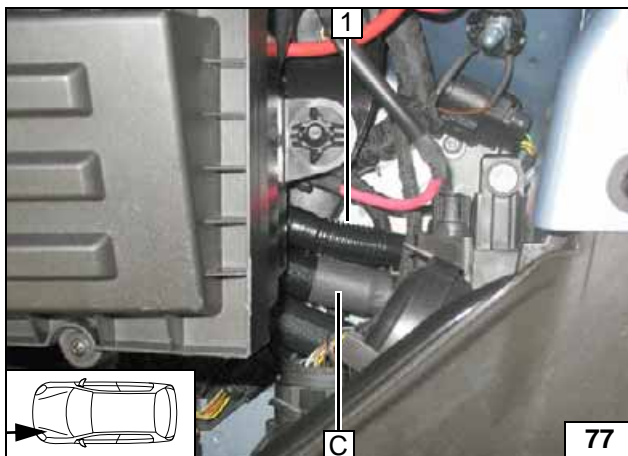

Version 1:

If drain pipe **1** is present as shown, then route parallel to coolant hose **C/D**.



Installing air cleaner housing

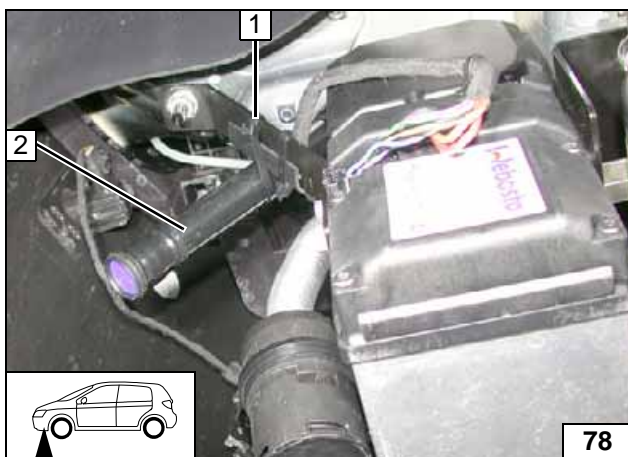

If drain pipe **2** is present as shown, then fasten on strut with cable tie **1**.



Fastening drain pipe on air filter box

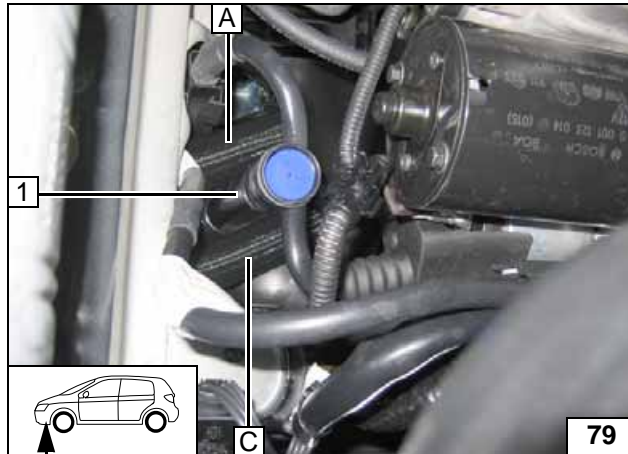
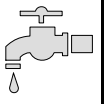

Version 2:

If drain pipe **1** is present as shown, route between coolant hoses **A/B** and **C/D**.



**Installing
air cleaner
housing**

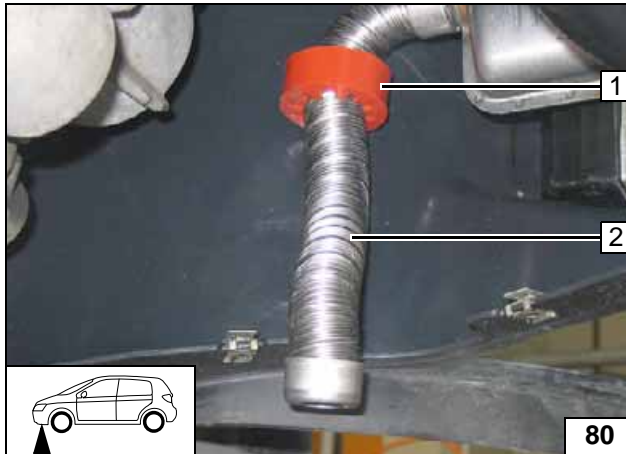
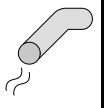

Exhaust gas

Align exhaust end section **2** and rubber isolator **1** as shown.
Ensure sufficient distance between exhaust end section and wheel well trim.



Installing wheel well trim

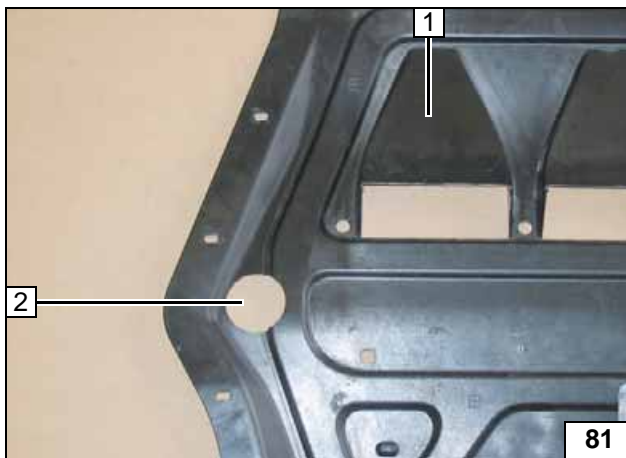

Remove insulation at position **2** if present.

- 1 Underride protection
- 2 42 mm dia. hole



Hole in underride protection

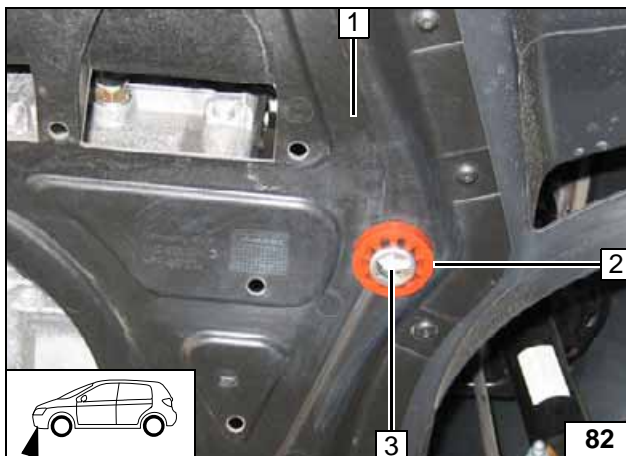

Align exhaust end section **3** flush on red rubber isolator **2**.

- 1 Underride protection



Inserting rubber isolator

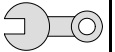

Final Work

WARNING!

Mount removed parts in reverse order. Check all hoses, clamps and all electrical connections for firm seating. Insulate and tie back all loose lines.

Only use manufacturer-approved coolant. Spray the heater components with anti-corrosion wax (Tectyl 100K, Order No. 111329).

- **Connect the battery**
- **Fill and bleed the coolant circuit according to the vehicle manufacturer's specifications.**
- **Set digital timer, teach telestart transmitter**
- **Make settings on A/C control panel according to the "Operating Instructions for End Customer".**
- **Place the "Switch off parking heater before refuelling" sticker near the filler neck.**
- **See installation instructions for initial start-up and function test**



Webasto AG
 Postfach 80
 D-82132 Stockdorf / Germany
 National Hotline: 01805 93 22 78
 (14 Cent aus dem deutschen Festnetz)
 Hotfax: 0395 5592 353
 Hotmail: hotline@webasto.de
<http://www.webasto.de>

Operating Instructions for End Customer

Please remove page and add to the vehicle operating instructions.



Note:

We recommend matching the heating time to the driving time.

Heating time = driving time

Example:

For a driving time of approx. 20 min. (in one direction), we recommend not exceeding a switch-on time of 20 min.

If the summer/winter switch option has been installed, this must be switched in accordance with the time of year. The heater will then heat in the position Winter  and in the position Summer  it will only switch on the vehicle fan to ventilate the vehicle interior.

Warning:

The passenger compartment monitoring must be deactivated for the duration of the heater operation.

Before parking the vehicle, make the following settings:

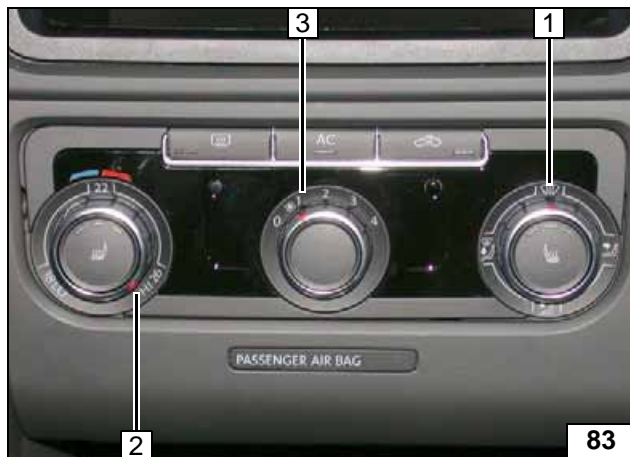

- 1 Air outlet to windscreen
- 2 Set temperature to "max."
- 3 Set fan to level "1", or possibly "2"



- 1 Air outlet to windscreen
- 2 Set temperature on both sides to "HI".

Climatic

Climatronic