

Water Heater



Thermo Top E Parking Heater

e1
00 0003

Thermo Top C Parking Heater

e1
00 0002

Installation documentation

Toyota IQ

Gasoline

from Model Year 2009

Left-hand drive vehicle

Gear box

Multi-drive transmission



WARNING!

Hazard warning:

Incorrect installation or repair of Webasto heating systems may cause a fire or result in the emission of carbon monoxide, which can be fatal. Serious or fatal injuries can be caused as a result.



Specialist company training, technical documentation, specialised tools and equipment are required to install and repair Webasto heating and cooling systems. Only original Webasto parts must be used. For this, also see the catalog of air and water heater accessories from Webasto.

NEVER attempt to install or repair Webasto heating or cooling systems if you have not successfully completed the company training and thereby acquired the required technical skills, or if you do not have access to the required technical documentation, tools and equipment needed to carry out correct installation and repairs.

ALWAYS follow all Webasto installation and repair instructions and observe all warnings.

Webasto does not accept any liability for defects and damage that are attributable to installation by untrained staff.

Table of Contents

Validity	2	Preparing heater	12
Heater/Installation Kit	3	Preparing installation location	12
Foreword	3	Installing bracket and heater	14
General Instructions	3	Fuel	15
Special Tools	3	Coolant circuit 1.0l	18
Explanatory Notes on Document	4	Coolant circuit 1.33l	19
Preliminary Work	5	Combustion air	26
Heater installation location	5	Exhaust gas	27
Preparing electrical system	6	Final Work	29
Electrical system	7	Template for Fuel Sender	30
Fan controller for manual air conditioning	8	Template for fuel standpipe	31
Automatic air-conditioning fan controller	9	Operating Instructions for End Customer	32
Remote option (Telestart)	11		

Validity

Manufacturer	Model	Type	EG-BE No./ABE
Toyota	IQ	AJ1	e6 * 2001/116 * 0119 * ...

Engine type	Engine model	Output in kW	Displacement in cm ³
1KR-FE	Gasoline	50	998
1NR-FE	Gasoline	72	1329

Vehicle and engine types, equipment variants and national specifications not listed in this installation documentation have not been tested. However, installation according to this installation documentation may be possible.

The installation location of a digital timer and summer/winter switch should be confirmed with the end customer before installation.

Heater/Installation Kit

Quantity	Description	Order No.:
1	Retail accessories with desired heater control	See price list
1	Installation Kit for Toyota IQ Gasoline	1314835B
1	Gasket of fuel-tank sending unit for Toyota IQ Gasoline	See Spare Parts Catalog for Toyota IQ

Heater recommended for the respective vehicle class:

Vehicle	Heater
Compact car	Thermo Top E
Mid-size car, station wagon	Thermo Top C

The selection of the heater is based on the passenger compartment size of the vehicle and the level of comfort required by the customer!



Foreword

This installation document applies to vehicles Toyota IQ Gasoline - for validity, see page 2 - from model year 2009 and later, assuming technical modifications to the vehicle do not affect installation, any liability claims excluded. Depending on the vehicle version and equipment, modifications may be necessary during installation with respect to this installation documentation.

However, where this is the case the stipulations in this "installation documentation" and "operating and maintenance instructions" for the *Thermo Top C* should be observed. The corresponding rules of technology and any information from the vehicle manufacturer should be observed during the installation work.

General Instructions

Installation should be carried out according to the general, standard rules of technology. Unless specified otherwise, fasten hoses, lines and wiring harnesses to original vehicle lines and wiring harnesses using cable ties.

Sharp edges should be fitted with edge protectors (split-open plastic hose).

Spray unfinished body areas, e.g. drilled holes, with anti-corrosion wax (Tectyl 100K, Order No. 111329).

Special Tools

- Torque wrench for 2.0 - 10 Nm
- Hose clamping pliers
- Metric thread-setter kit

Explanatory Notes on Document

To provide you with a quick overview of the individual working steps, you will find an identification mark on the outside top right corner of the page in question.

Mechanical system

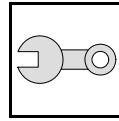

Electrical system

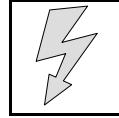

Coolant circuit

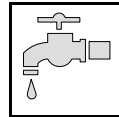

Fuel

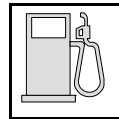

Exhaust gas

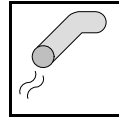

Combustion air

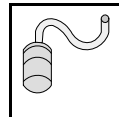

Software

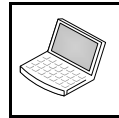

Special features are highlighted using the following symbols:



Specific risk of injury or fatal accidents.



Specific risk of damage to components.



Specific risk of fire or explosion.



Reference to general installation instructions of Webasto components or to the manufacturer's vehicle-specific documents.



Reference to a special technical feature.

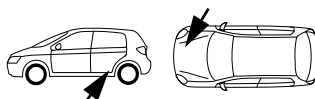

The arrow in the vehicle icon indicates the position on the vehicle and the viewing angle.

All dimensions are in mm!

Tightening torque of hose clamps = 2.0 + 0.5 Nm!

Tightening torque of Ejet screws, Ejet studs = 10 Nm!

Preliminary Work

WARNING!

- Open the fuel tank cap, ventilate the tank.
- Close the tank cap again.
- Disconnect the battery "earth" or "ground" connection.
- Depressurize the cooling system.
- Copy the factory number from the original type label to the duplicate type label.
- Remove years that do not apply from the duplicate label.
- Attach the duplicate label (type label) in the appropriate place.
- Remove the battery completely.
- Remove the battery carrier plate.
- Remove control unit (only for 1.33l)
- Remove the basic battery carrier.
- Remove the air filter together with the intake hose.
- Remove the left-hand underride protection.
- Remove the trim on the left before the fuel tank.
- Remove the fuel tank trim.
- Remove the fuel tank according to the manufacturer's specifications.
- Remove the fuel-tank sending unit according to the manufacturer's instructions (1st fuel-tank sending unit/pump unit in driving direction).
- Remove the entrance strip on the left.
- Remove the lower A-pillar trim in the footwell on the left.
- Remove the instrument panel trim below the steering wheel.
- Remove the trim of the handbrake lever/gearshift (only with automatic air-conditioning).
- Remove the lower trim/storage compartment (centre console) before the gearshift (only with automatic air-conditioning)
- Detach the lower trim of the centre console (only with automatic air-conditioning).

Remove page 32 "Operating Instructions for End Customer" and add to the vehicle operating instructions.



Heater installation location

1 Heater

Installation location

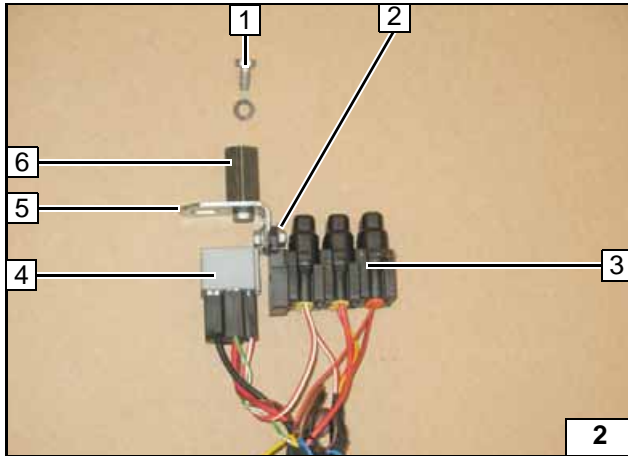

Preparing electrical system

- 1 M6x12 bolt, spring lockwasher
- 2 M5x16 bolt, washer, flanged nut
- 3 Fuse holder
- 4 Relay K3
- 5 Angle bracket
- 6 M6x30 spacer nut, spring lockwasher, M6x12 bolt



Premounting fuse holder and K3 relay



Electrical system

Fuse holder, K3 relay

- 1 M6x12 bolt, spring lockwasher, original vehicle hole
- 2 Fuse holder and K3 relay premounted

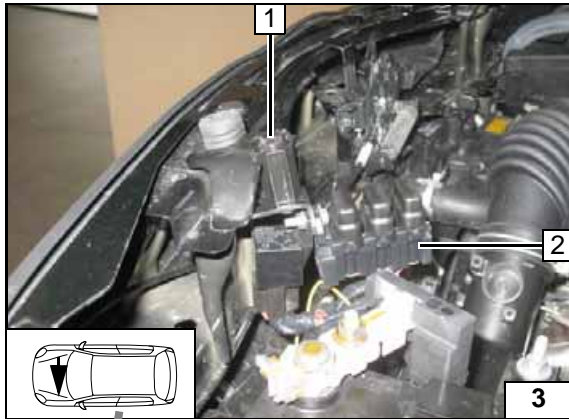

Digital timer

- 1 Digital timer

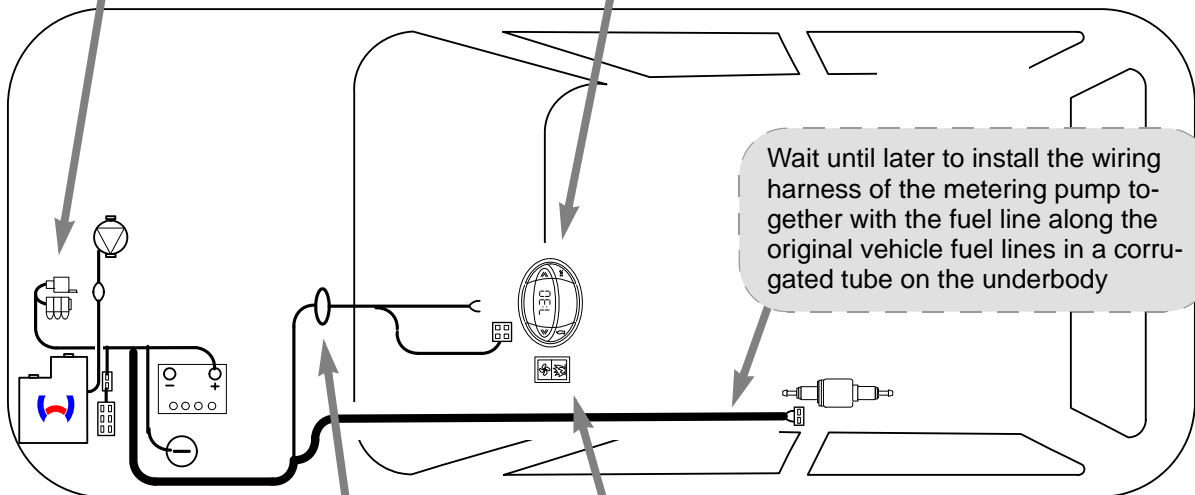

Wiring harness installation diagram

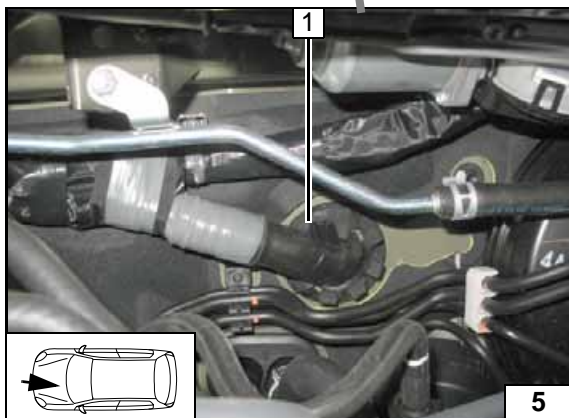

Wiring harness pass through

- 1 Protective rubber plug



Summer/winter switch option

- 1 Summer/winter switch, drilled hole 12 mm dia.



Fan controller for manual air conditioning

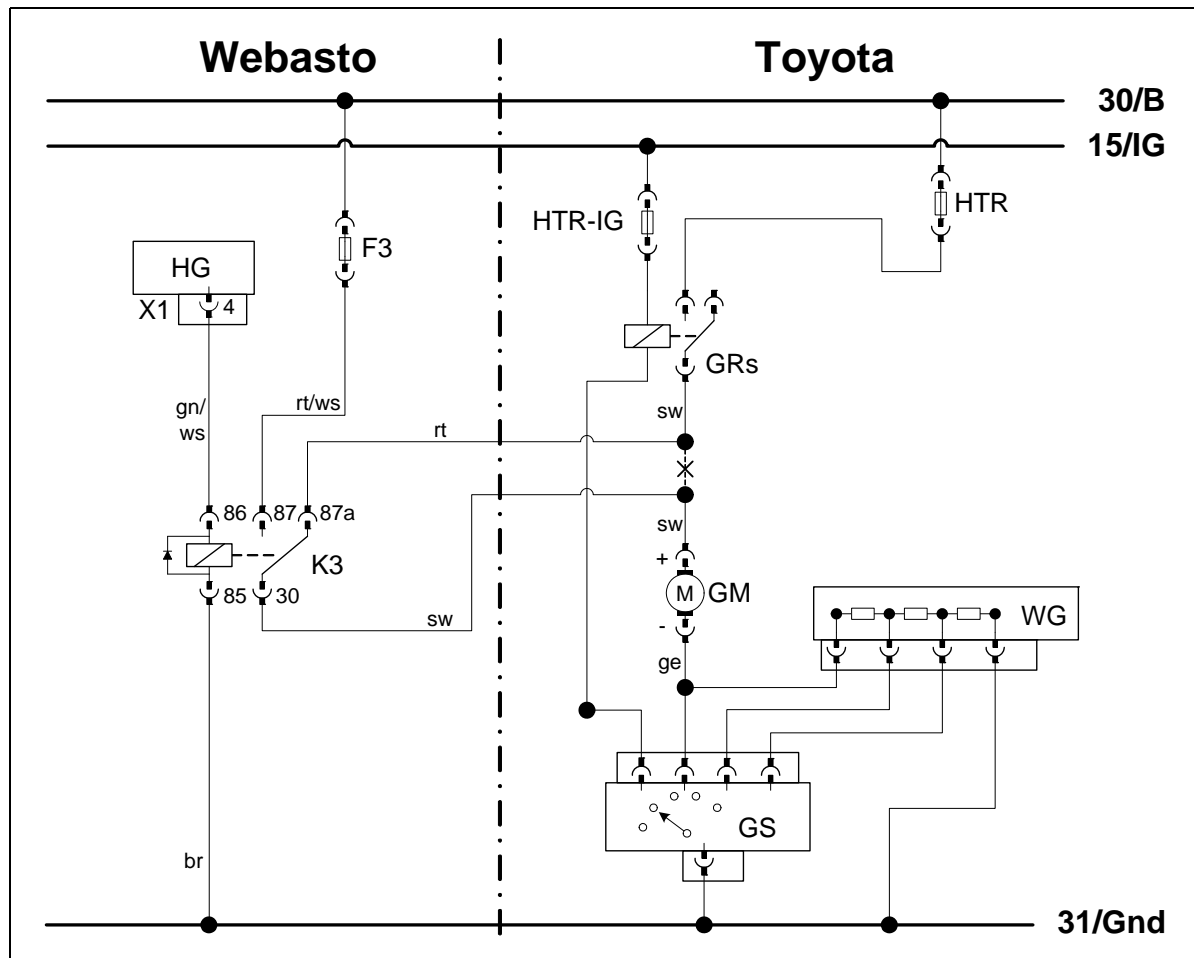

Wiring diagram

Webasto components		Vehicle components		Colours and symbols	
HG	Heater TT-C/E	GM	Fan motor	rt	red
X1	6-pin heater connector	GRs	HTR fan relay	ws	white
F3	25 A fuse	GS	Fan switch	sw	black
K3	Fan relay	WG	Resistor group	br	brown
		HTR	40 A fuse	gn	green
		HTR-IG	10 A fuse	ge	yellow
				X	Cutting point
				Wiring colours may vary.	

Legend

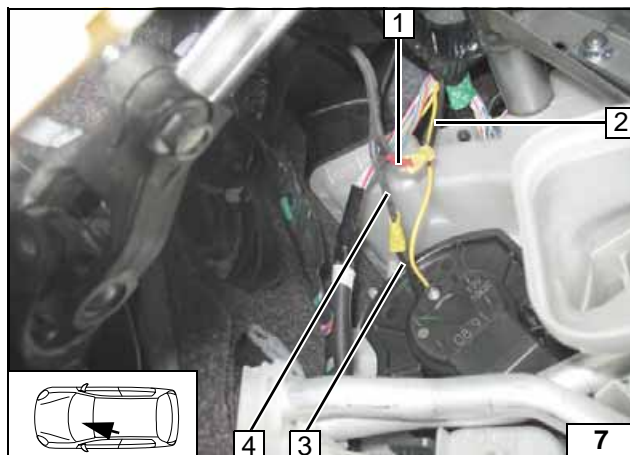

Connection to 2-pin connector 1 from the blower motor.
Produce connections as shown in wiring diagram.

- 1 Red (rt) wire of K3/87a
- 2 Black (sw) wire of HTR relay
- 3 Black (sw) wire of 2-pin connector
- 4 Black (sw) wire of K3/30



Connecting fan-motor



Automatic air-conditioning fan controller



Wiring diagram

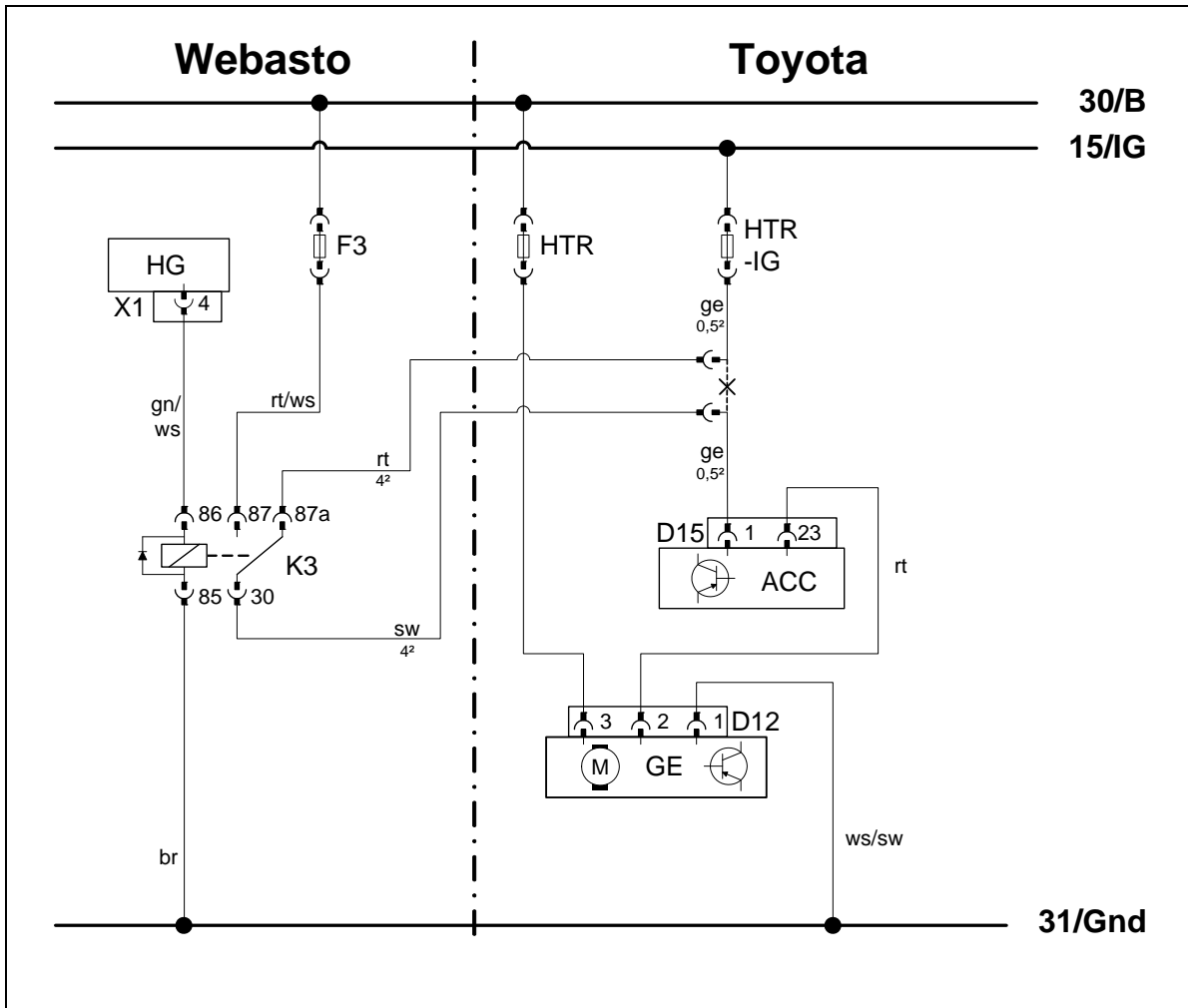

Webasto components		Vehicle components		Colours and symbols	
HG	Heater TT-C/E	GE	Fan unit	rt	red
X1	6-pin heater connector	E12	GE connector	ws	white
F3	Replace 25 A with 10 A fuse.	ACC	AC control	sw	black
K3	Fan relay	D15	40-pin ACC connector	br	brown
		HTR	40 A fuse	gn	green
		HTR-IG	10 A fuse	ge	yellow
				X	Cutting point
					Wiring colours may vary.

Legend

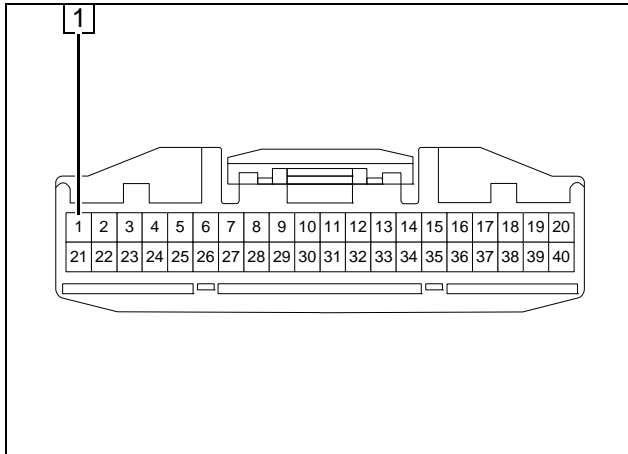

1 Connector D15 on contact side (Pin 1)



Connector D15

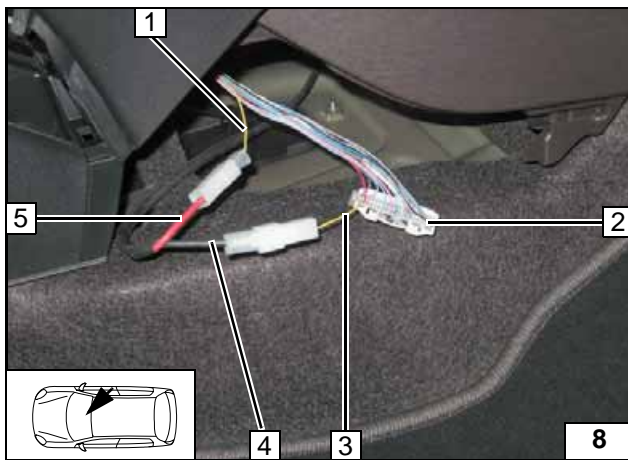

Connection to 40-pin connector 2 from ACC. Produce connections as shown in wiring diagram.



- 1 Yellow (ge) wire of Fuse HTR IG
- 3 Yellow (ge) connector D15
- 4 Black (sw) wire of K3/30
- 5 Red (rt) wire of K3/87a

Connecting A/C control panel

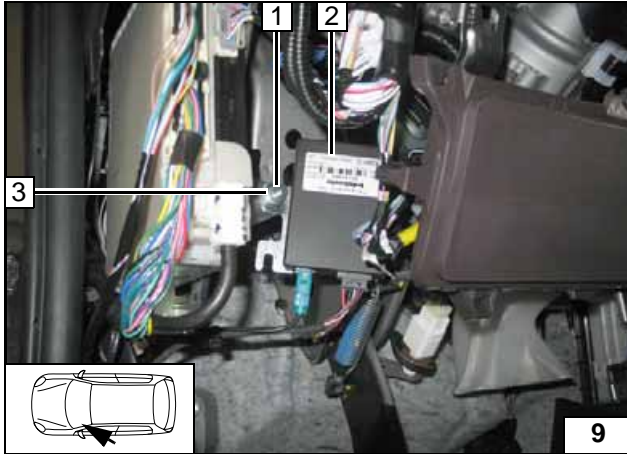

Remote option (Telestart)

- 1 Original vehicle bolt
- 2 Receiver
- 3 Bracket of receiver, hole drilled out to 6.5 mm dia.



Installing receiver

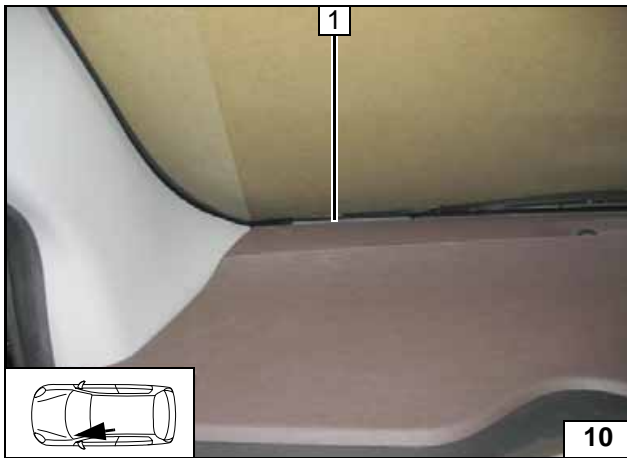

- 1 Antenna

Installing antenna

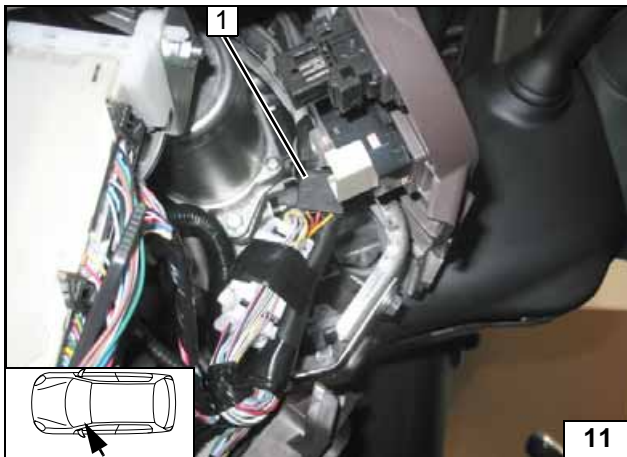

Temperature sensor HTM100

Fasten temperature sensor 1 to original vehicle wiring harness with cable tie.



Installing temperature sensor

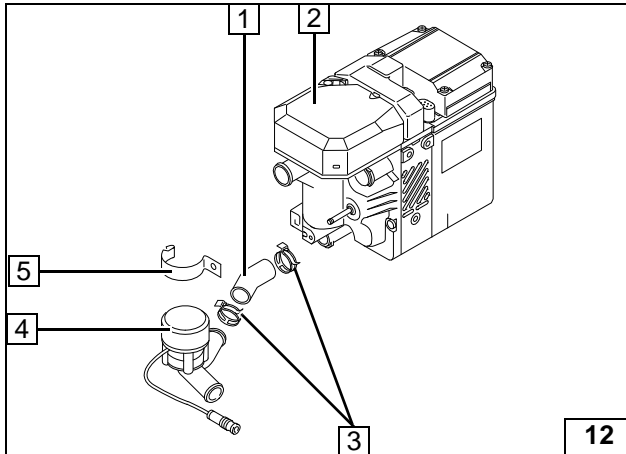
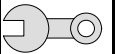

Preparing heater

- 1 Molded hose, discard
- 2 Heater
- 3 27 mm dia. spring clip [2x], will be reused
- 4 Circulating pump
- 5 Retaining clip, discard



Removing circulating pump

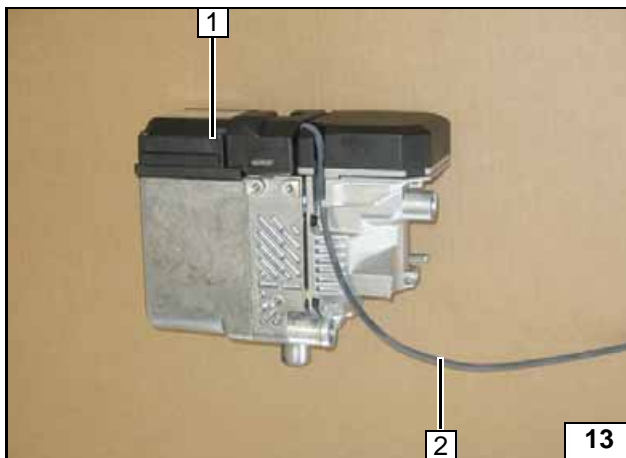

- 1 Heater
- 2 Adapter cable of circulating pump

Installing adapter cable for circulating pump

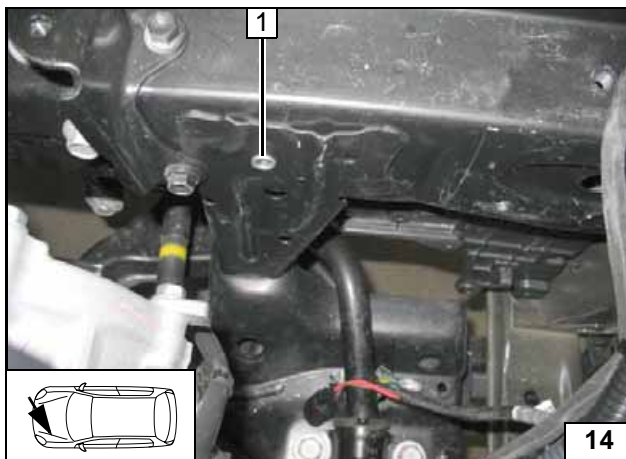

Preparing installation location

Mount M6 rivet nut in original vehicle hole 1!



Installing rivet nut

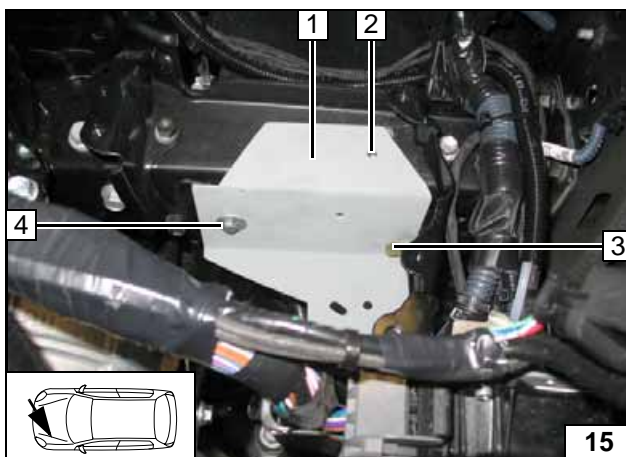

- 1 Bracket
- 2 Hole pattern, 9.1 mm dia. hole
- 3 M8x30 bolt, 5 mm shim
- 4 M6x30 bolt, washer, 5 mm shim



Copying hole pattern

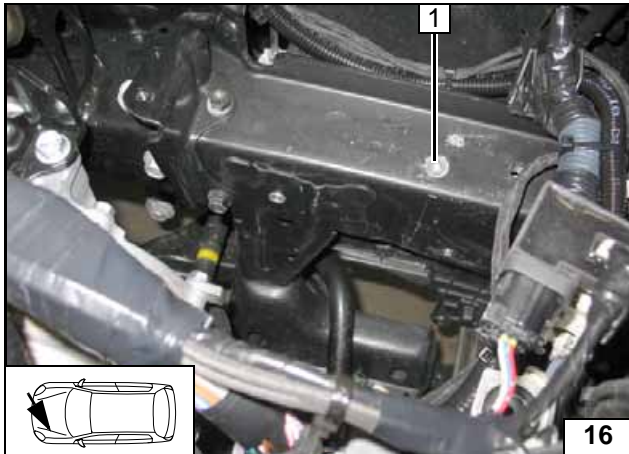
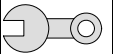

1 M6 rivet nut

Installing rivet nut

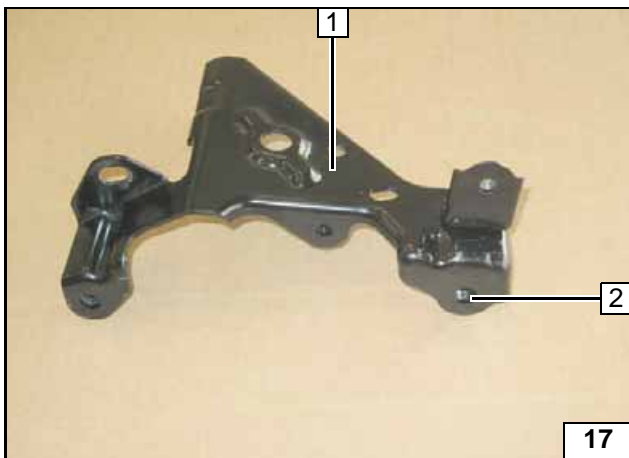

1 Basic battery carrier
2 Drill out thread (9.0 mm dia.)

Preparing basic battery carrier

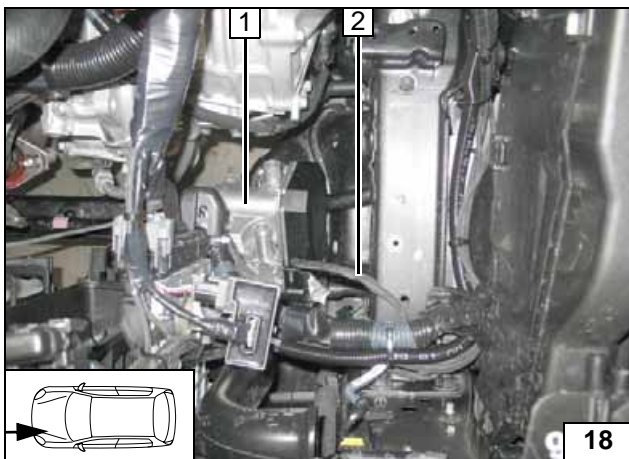

Set down heater 1 and connect wiring harness 2.

Preparing installation

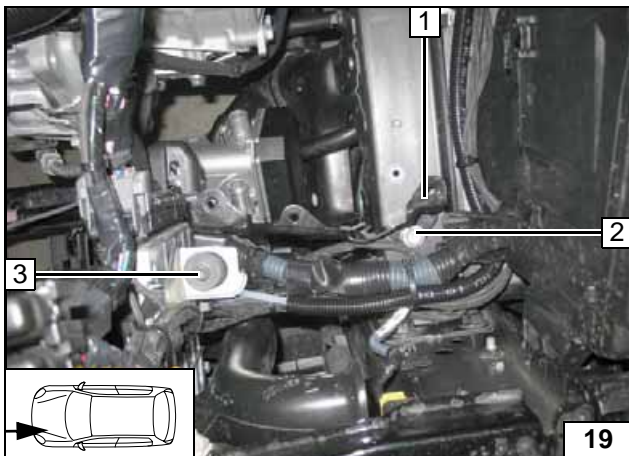

1 Basic battery carrier
2 Original M8 vehicle bolt
3 Original M6 bolt of vehicle

Installing basic battery carrier

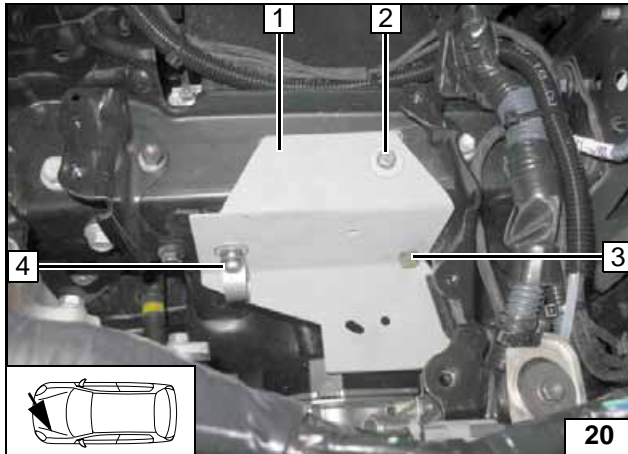
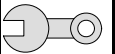

Installing bracket and heater

Screw fitting **4** is first installed loosely and then tightened later when combustion-air intake pipe is routed.

- 1** Bracket
- 2** M6x20 bolt, spring lockwasher, large diameter washer
- 3** M8x30 bolt, spring lockwasher, 5 mm shim
- 4** M6x30 bolt, spring lockwasher, p-clamp, large diameter washer, 5 mm shim

Installing bracket

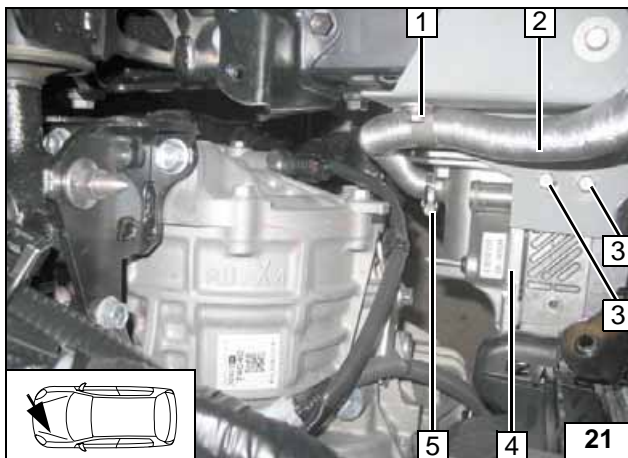

Ensure proper spacing between transmission and combustion air pipe **2**.
Tighten screw fitting **1**.

- 3** Ejoy screw [2x]
- 4** Heater
- 5** 27 mm dia. clamp

Installing heater and combustion air pipe





Fuel

CAUTION!

Open the vehicle's fuel tank cap, ventilate the tank and then re-close the tank lock.

Catch any fuel running off with an appropriate container.

Install fuel line and metering-pump wiring harness so that they are protected against stone impact. Unless specified otherwise, always fasten using cable ties. Mount the fuel line and wiring harness with rub protection on sharp edges.

WARNING!

The fuel line and wiring harness are routed to the metering pump in as shown in the wiring harness routing diagram.

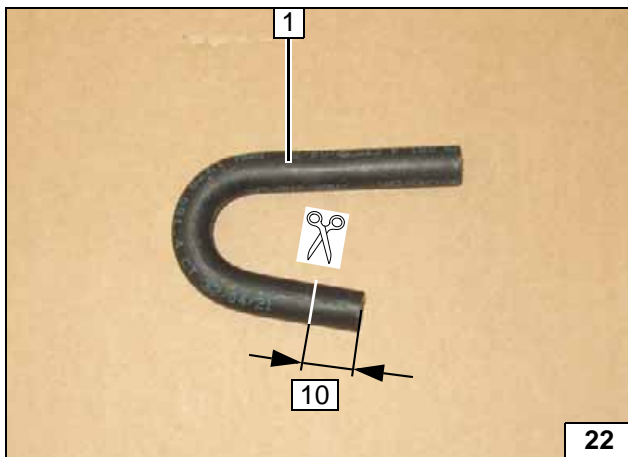

1 180° molded hose

Preparing connection of heater

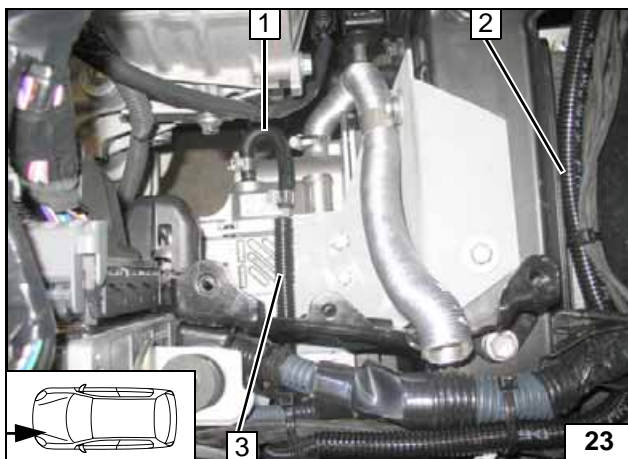

Check the position of the components; adjust if necessary. Check that they have free clearance.

- 1 Molded hose, 10 mm dia. clamp [2x]
- 2 Wiring harness of metering pump, fuel line in corrugated tube
- 3 Corrugated tube, fuel line



Preparing connection of heater

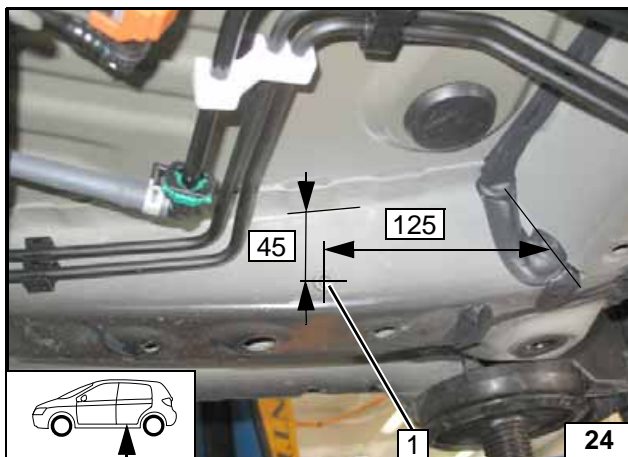

1 9.1 mm dia. hole; M6 rivet nut



Installation location of metering pump

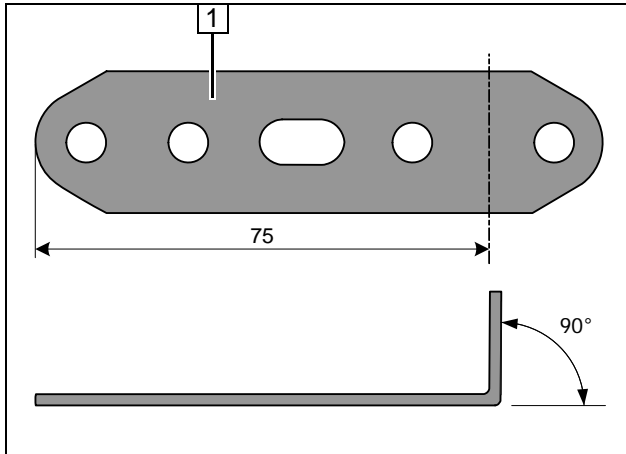

1 Perforated bracket

Bending perforated bracket



1 M6x20 bolt, spring lockwasher
2 Perforated bracket

Installing perforated bracket

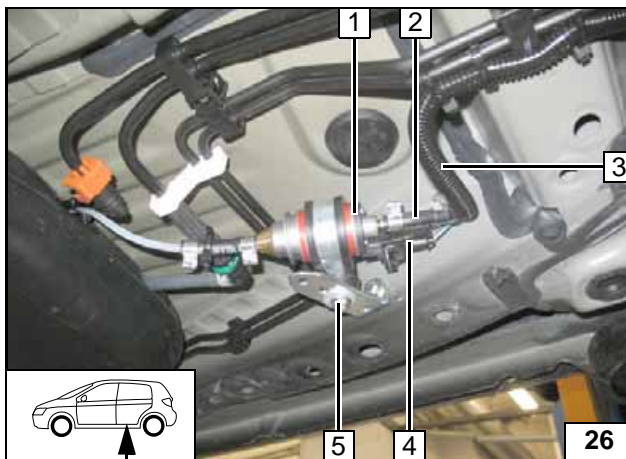

1 Metering pump, rubber-coated p-clamp, silent block, M6 flanged nut
2 Hose section, 10 mm dia. clamp [2x], fuel line
3 Corrugated tube, fuel line, wiring harness of metering pump
4 Metering pump wiring harness
5 Flanged nut, large diameter washer



Installing and connecting metering pump

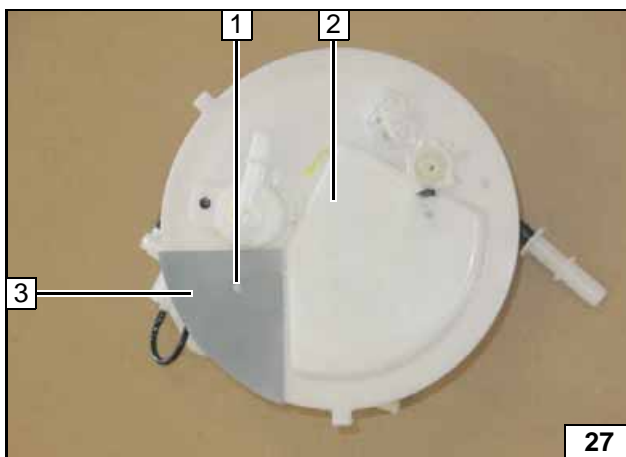

Remove the fuel tank according to the manufacturer's specifications. Remove fuel-tank sending unit 2 in accordance with manufacturer's specifications. Cut out template 3, lay on fuel-tank sending unit 2 and copy hole pattern 1. 6.0 mm dia. hole at position 1 Watch for chips when drilling.



Removing fuel

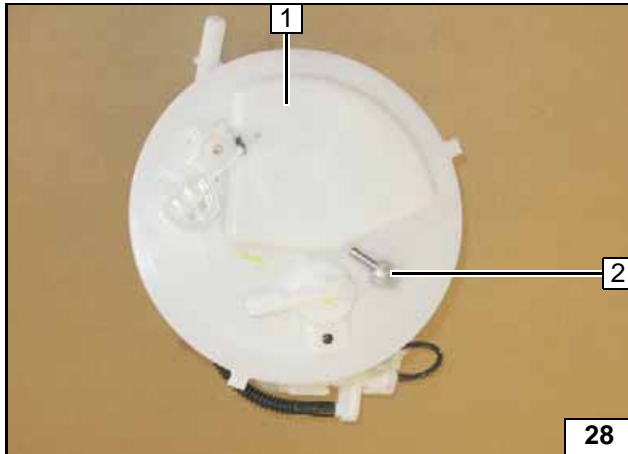

Shape fuel standpipe **2** according to template, cut to length and install.

1 Fuel-tank sending unit



Installing fuel standpipe

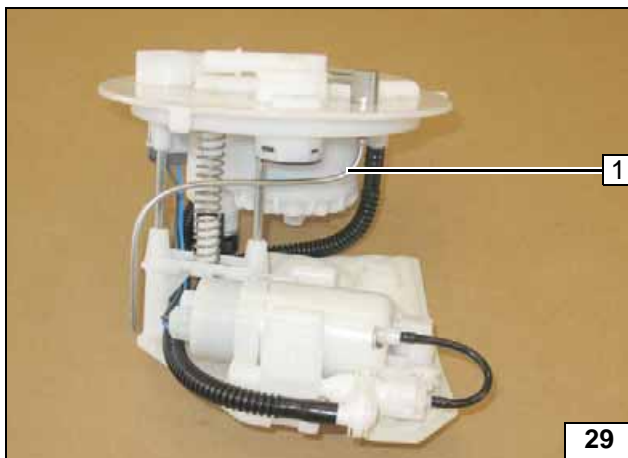

Shape fuel standpipe **1** according to template, cut to length and install.



Installing fuel standpipe

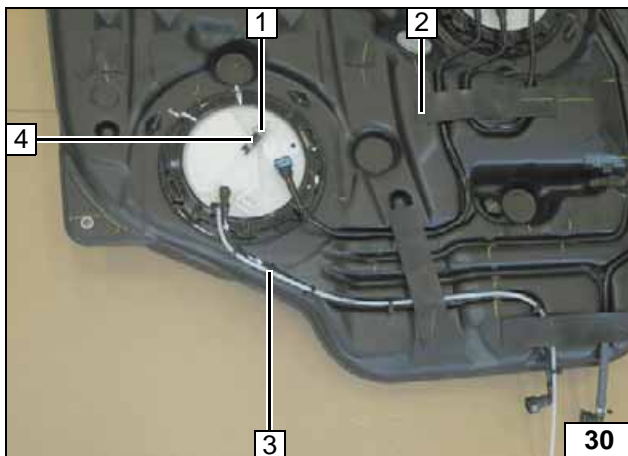

Install fuel-tank sending unit in accordance with manufacturer's instructions. Route fuel line **3** along original vehicle fuel line and secure with cable ties.

1 Fuel standpipe
2 fuel tank
4 Hose section, 10 mm dia. clamp [2x]



Connecting fuel line

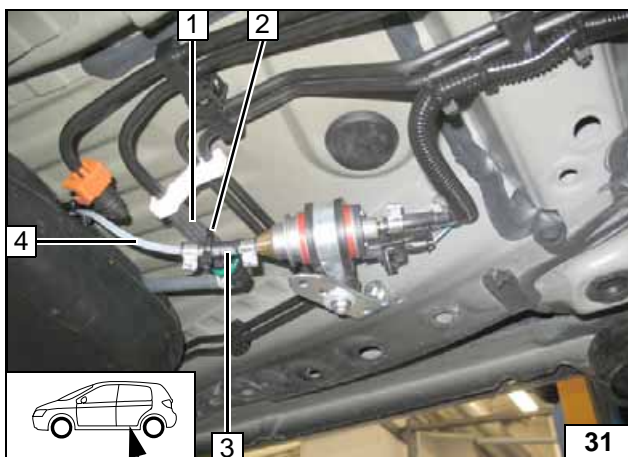

Install fuel tank in accordance with manufacturer's specifications.

Check the position of the components; adjust if necessary. Check that they have free clearance.

Cut open hose **1** (8x12/70 mm) and position on original vehicle fuel line.

2 Cable tie
3 Hose section, 10 mm dia. clamp [2x]
4 Fuel line



Connecting metering pump

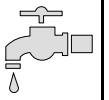



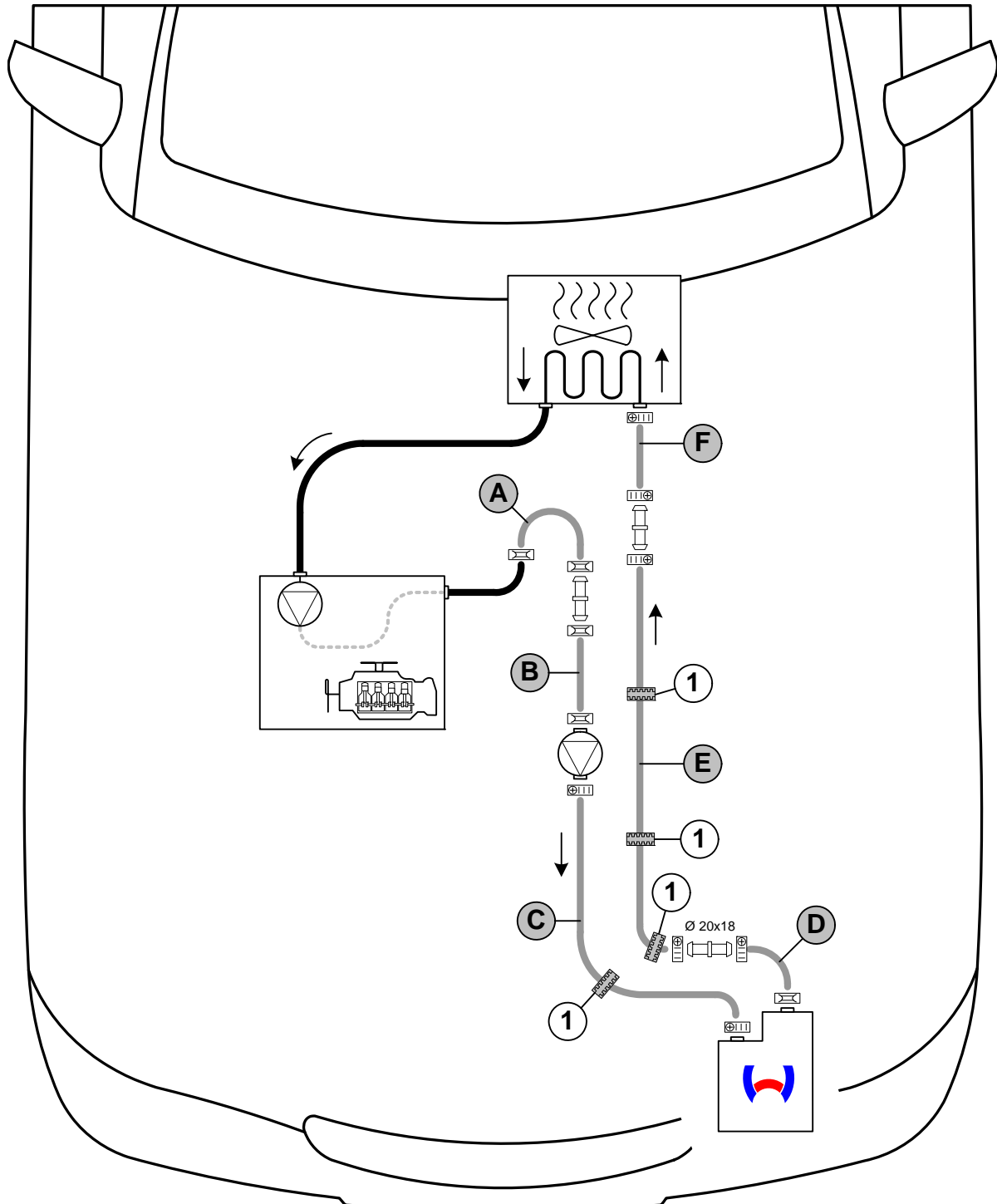

Coolant circuit 1.0l

WARNING!

Any coolant running off should be collected using an appropriate container! Install hoses so that they are kink-free. Unless specified otherwise, always fasten using cable ties. Position clamps so that no other hose can be damaged! When installing the hoses, the heater must be filled with coolant. The connection should be "inline" based on the following diagram:



Hose routing diagram

All spring clips  = 27 mm dia.! All connecting pipes without a specific designation  = dia. 20x20.
All hose clamps  = 16-27 mm dia. 1 = Black (sw) rubber isolator .



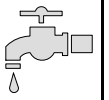



Coolant circuit 1.33l

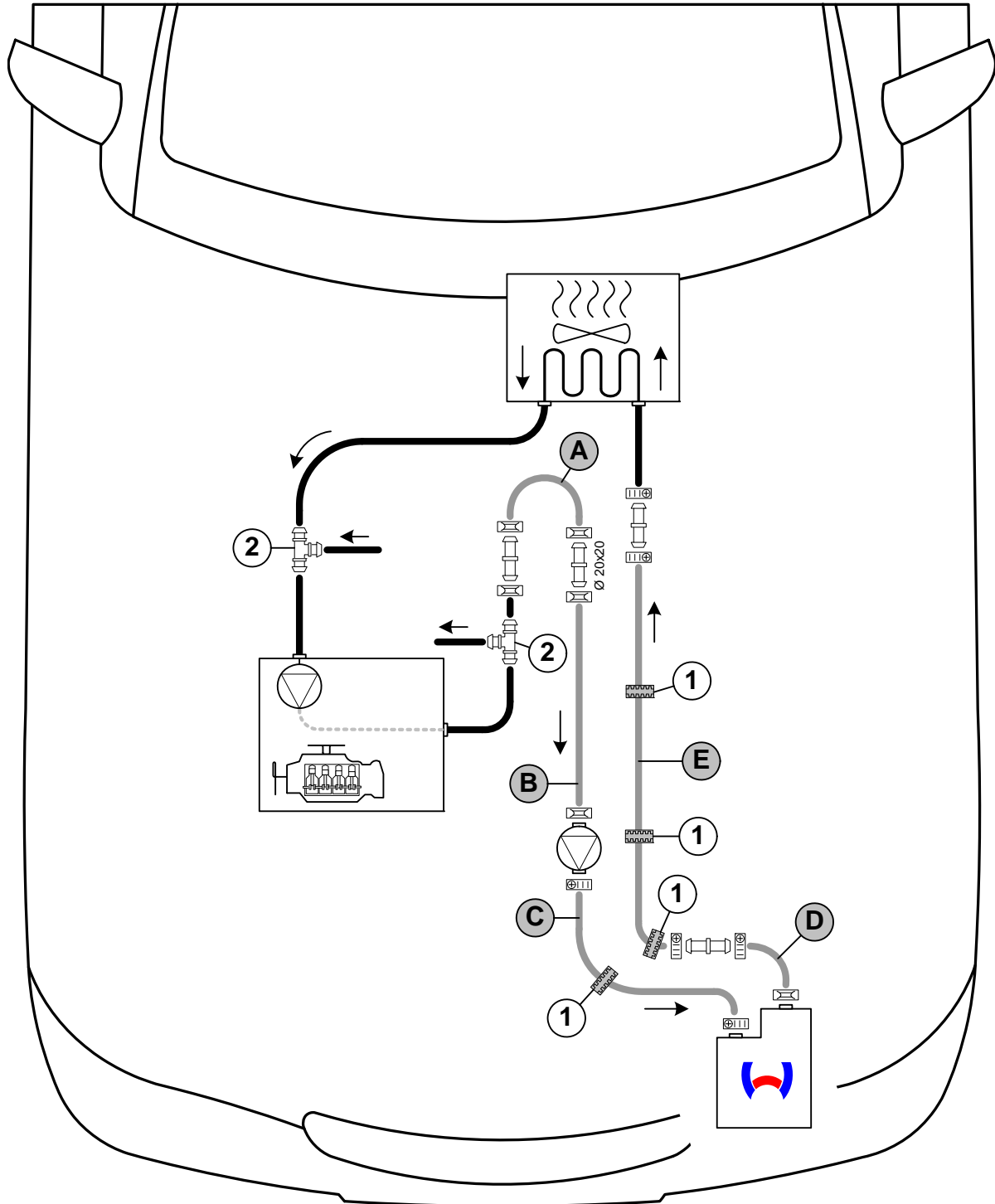

WARNING!

Any coolant running off should be collected using an appropriate container! Install hoses so that they are kink-free. Unless specified otherwise, always fasten using cable ties. Position clamps so that no other hose can be damaged! When installing the hoses, the heater must be filled with coolant. The connection should be "inline" based on the following diagram:



Hose routing diagram

All spring clips  = 27 mm dia.! All connecting pipes without a specific designation  = dia. 18x20.

All hose clamps  = 16-27 mm dia. **1** = Black (sw) rubber isolator  [4x]!.

2 = Original vehicle T-piece [2x]  (for multi-drive transmission only)!



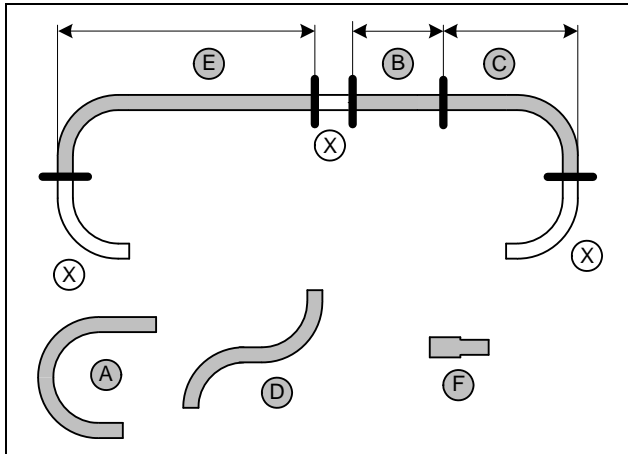
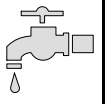

1.0l

Discard section **X**

- A = Moulded hose 180°
- D = Moulded hose
- F = 20x18 moulded hose

- B = 200
- C = 355
- E = 635

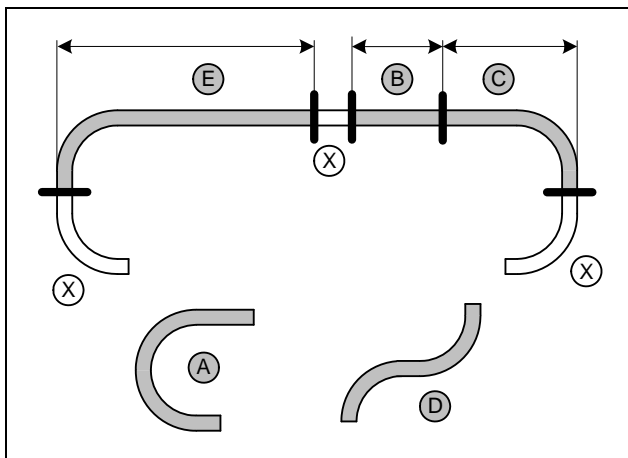

1.33l manual transmission

Discard section **X**

- A = Moulded hose 180°
- D = Moulded hose

- B = 200
- C = 355
- E = 520

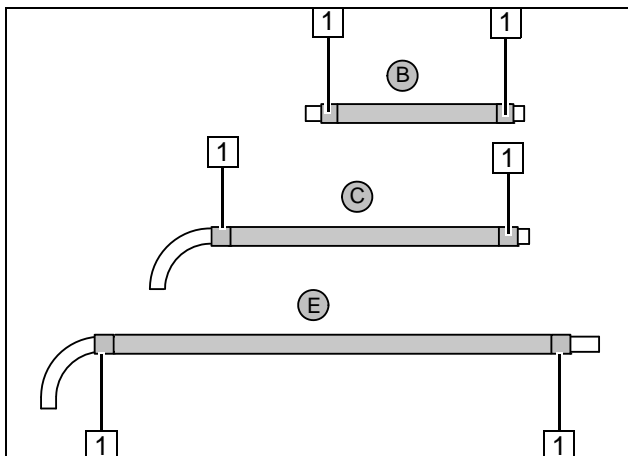

All vehicles

Slide braided protection hoses onto hose **B**, **C** and **E** and cut to length.

- 1 50 mm long heat shrink plastic tubing [6x]

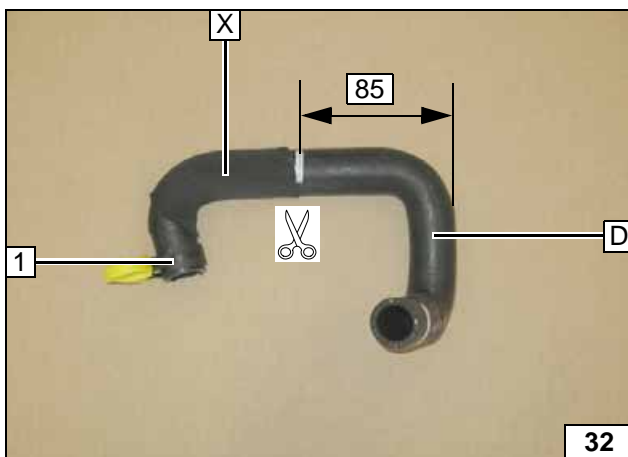

Discard section **X**.

- 1 Spring clip will be reused



Cutting coolant hoses to length



Cutting coolant hoses to length



1.33l Multi-drive transmission

The hose lengths **B** and **E** are to be adjusted appropriately during installation!



Preparing coolant hoses



Preparing moulded hose D

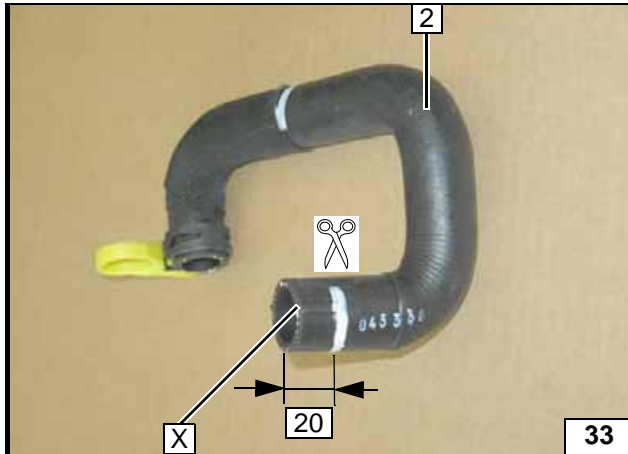

Discard section X



Preparing moulded hose D

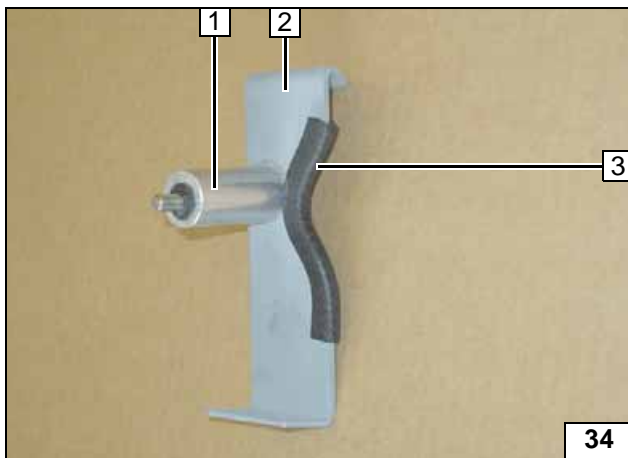

Cut edge protection section provided in half.

- 1 M6x60 bolt, 40 mm spacer, pin lock
- 2 Strut
- 3 Edge protection section



Preparing strut

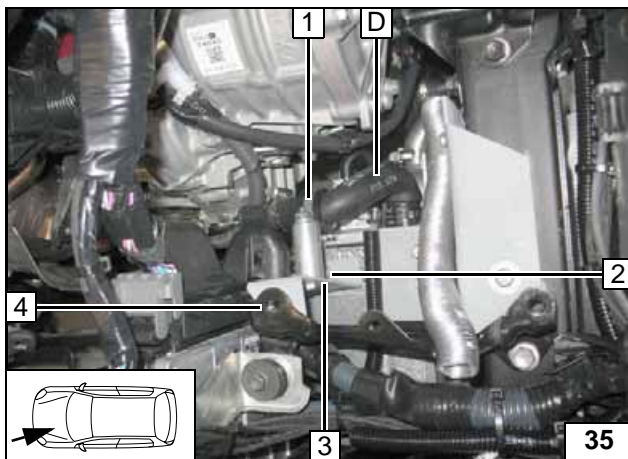
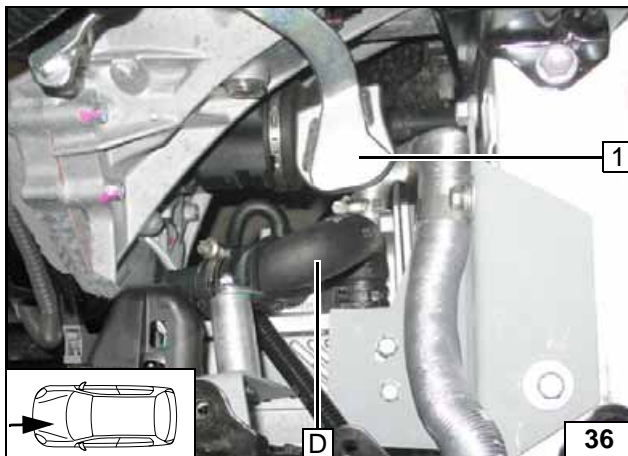

Figure shows multi-drive transmission
Align strut 3 relative to basic battery carrier 4.
Check the position of the components; adjust if necessary. Check that they have free clearance.

- 1 29 mm dia. rubber-coated p-clamp, flanged nut
- 2 Ejet screw
- 3 Strut



Connecting heater



Ensure sufficient spacing of hose D to shift mechanism 1 on manual transmission.



Connecting heater

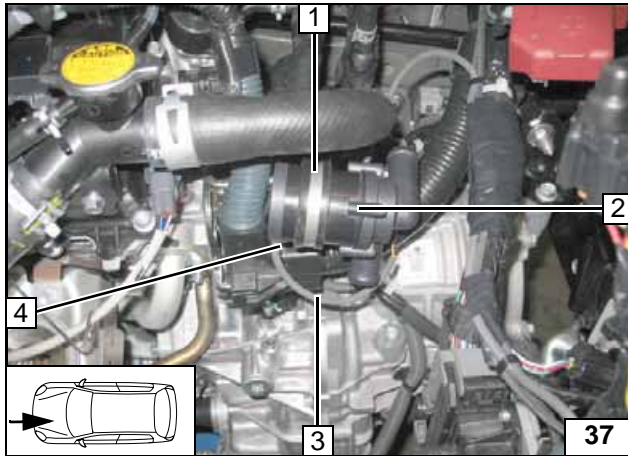

Connect cable of circulating pump 3 with same colours of adapter cable of circulating pump!
Remove original vehicle bolt 4.
Observe direction of flow.

- 1 48 mm dia. rubber-coated p-clamp, M6x40 bolt, spring lockwasher, 20 mm shim
- 2 Circulating pump



Installing circulating pump

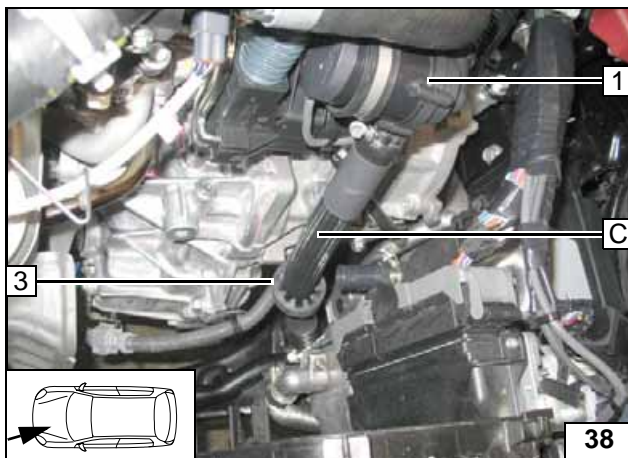

Align black (sw) rubber isolator 3.

- 1 Circulating pump



Connecting heater and circulating pump



1.0l

Remove original vehicle hose 1. Spring clip will not be reused!



Cutting point

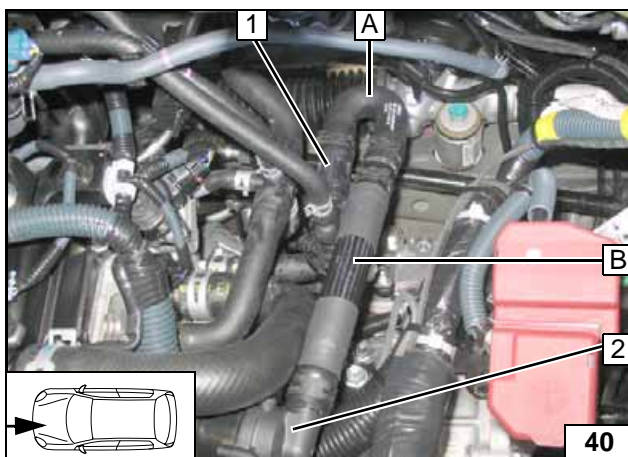

- 1 Connection piece for engine outlet
- 2 Circulating pump



Connecting engine outlet and circulating pump

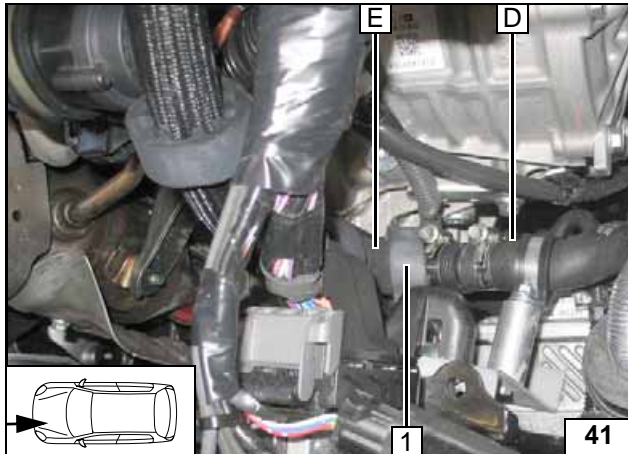
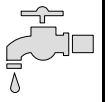

Aligning black (sw) rubber isolator 1.



Connect-
ing heater

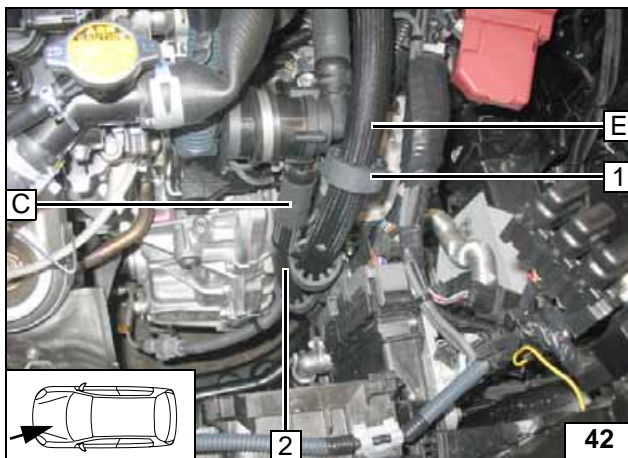

Align black (sw) rubber isolator1.

2 Black (sw) rubber isolator, cable tie on hose C



Routing in
engine
compart-
ment

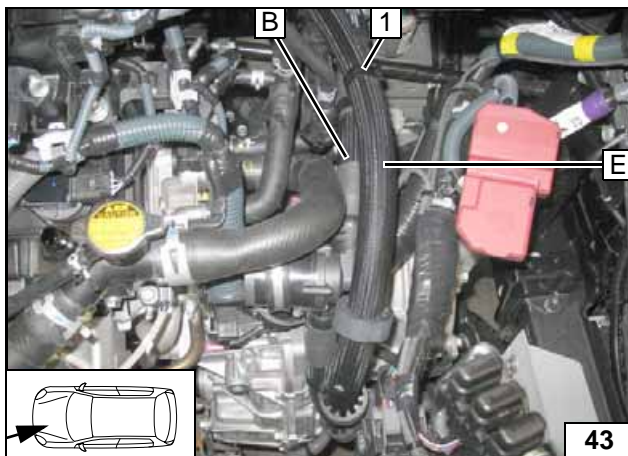

Position spacer bracket 1 between hose B and hose E!



Routing in
engine
compart-
ment

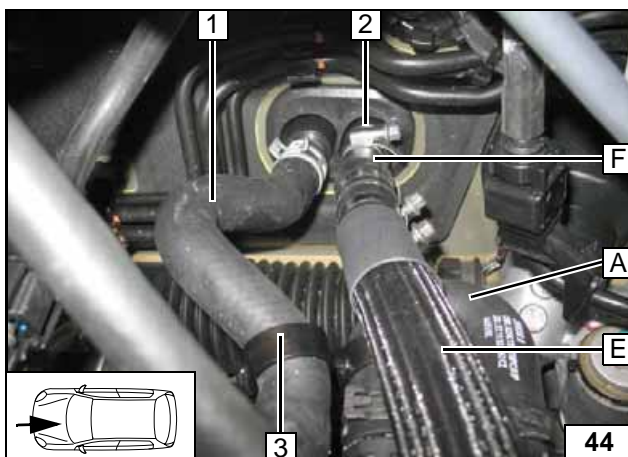

Position spacer bracket 3 between original vehicle hose 1 and hose A!

2 Connection piece of heat exchanger inlet



Connect-
ing heat
exchanger
inlet

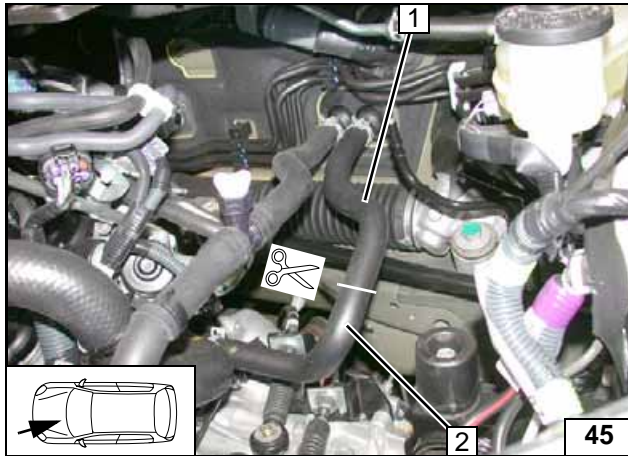

1.33l manual transmission

Cut the original vehicle hose of engine outlet / heat exchanger inlet at the marking.

- 1 Hose section of heat exchanger inlet
- 2 Engine-outlet hose section

Cutting point

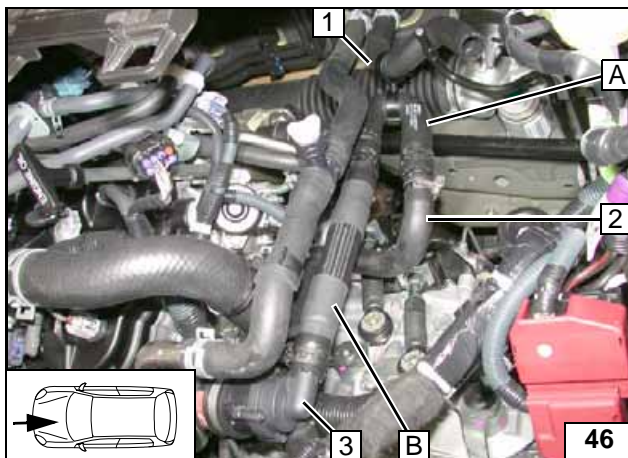

- 1 Spacer bracket
- 2 Hose of engine outlet
- 3 Circulating pump

**Connect-
ing engine
outlet and
circulating
pump**

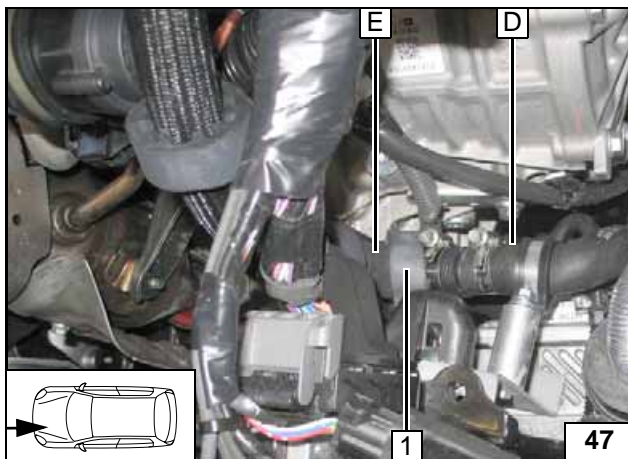

Aligning black (sw) rubber isolator 1.

**Connect-
ing heater**



Aligning black (sw) rubber isolator 1.

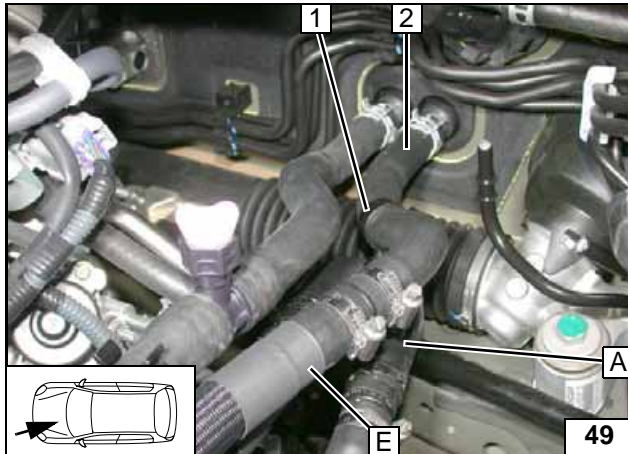
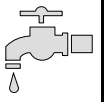

**Routing in
engine
compart-
ment**



Position spacer bracket **1** between hose of heat exchanger inlet **2** and hose **A**!

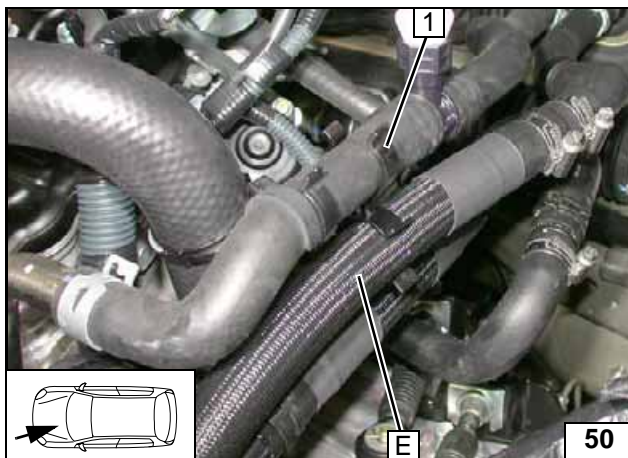

**Connect-
ing heat
exchanger
inlet**



Position spacer bracket **1** between original vehicle hose and hose **E**!



**Connect-
ing heat
exchanger
inlet**

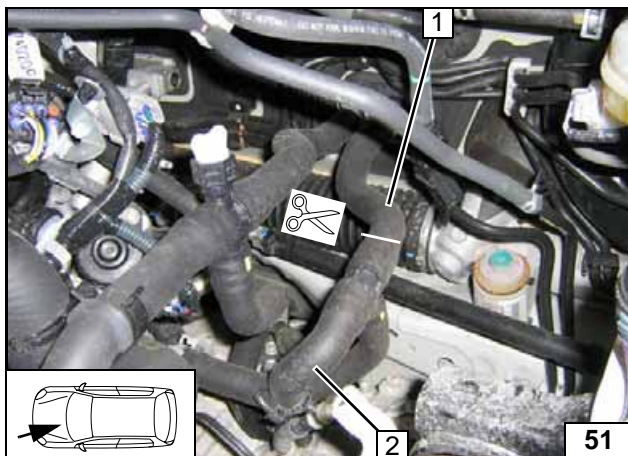

1.33l Multi-drive transmission

Cut the original vehicle hose of engine outlet / heat exchanger inlet at the marking behind the T-piece.

- 1** Hose section of heat exchanger inlet
- 2** Engine-outlet hose section



**Cutting
point**

The corresponding worksteps are more or less identical to those of the 1.33l manual transmission and they differ only in the vehicle-side installation of two T-pieces. The shortening of hose **E** and **B** must be adjusted accordingly.



Routing

All the hoses are routed and secured according to the general applicable rules of technology. Please ensure protection against sharp edges as well as sufficient distance from hot or moving components.

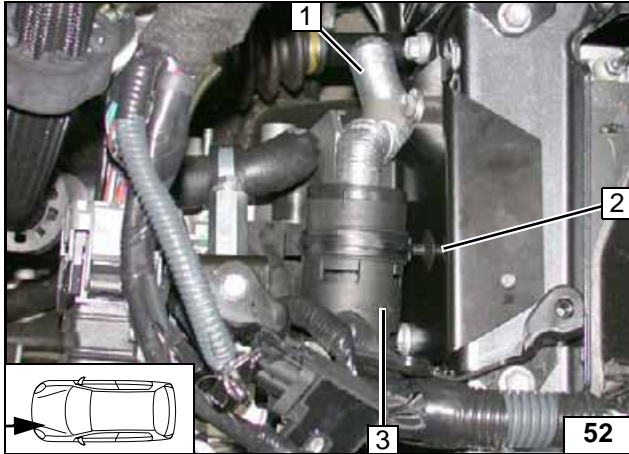
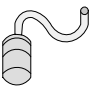

Combustion air

Reinstall after assembly of the control unit in 1.33!

- 1 Combustion air pipe
- 2 Retaining clip in 6.2 mm
- 3 Muffler



**Installing
muffler**

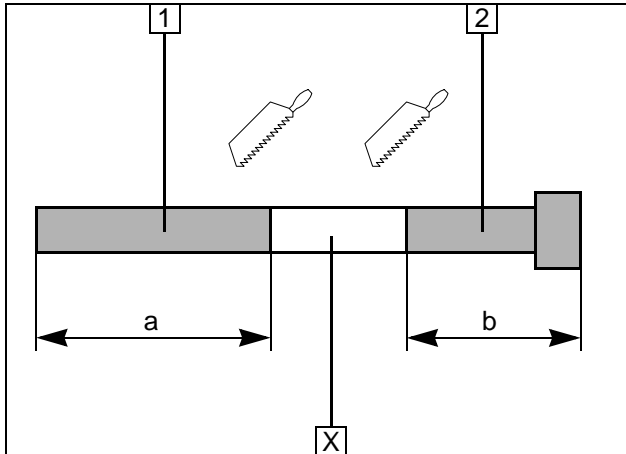
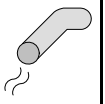

Exhaust gas

- 1 Exhaust pipe
a = 340
- 2 Exhaust end section
b = 200

Discard section X

Preparing exhaust pipe

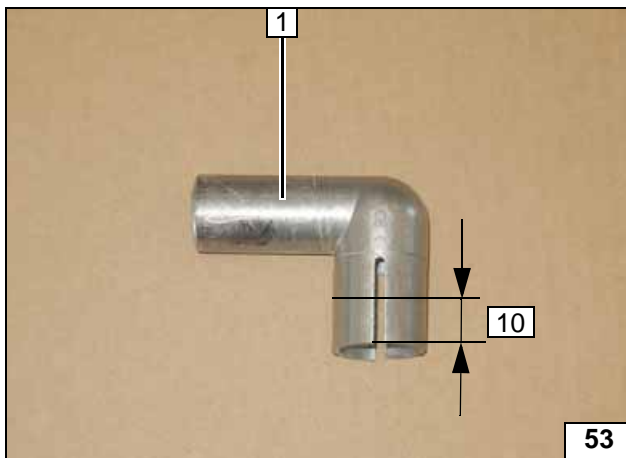

Shorten exhaust manifold 1.

Preparing exhaust manifold

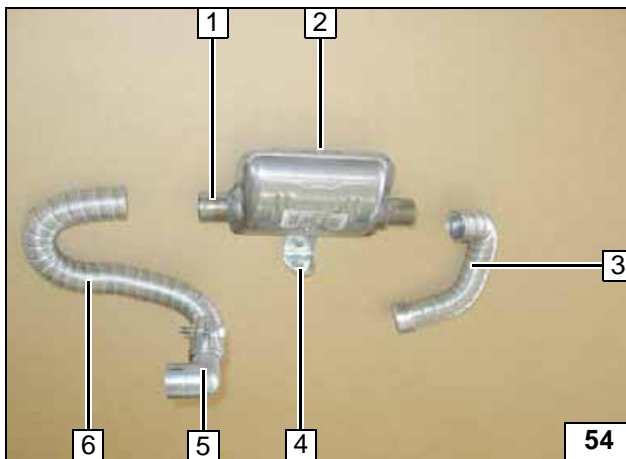

Close off condensed-water drain opening 2 in exhaust muffler 1.

- 3 Exhaust-pipe end section
- 4 Angle bracket, M6x20 bolt, flanged nut
- 5 Exhaust manifold
- 6 Exhaust pipe, hose clamp

Preparing exhaust pipe

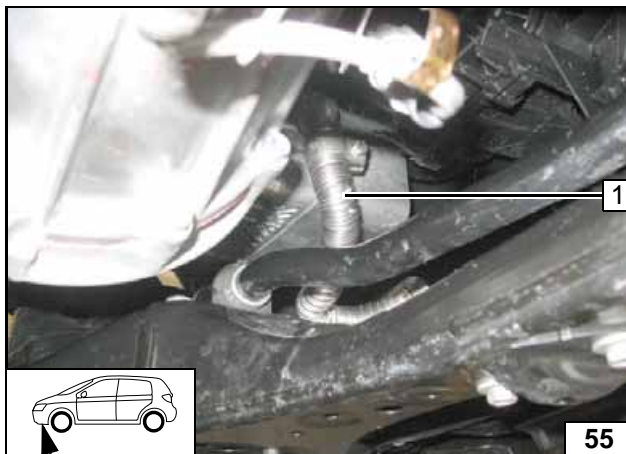

1 Exhaust pipe premounted, hose clamp

Installing exhaust pipe

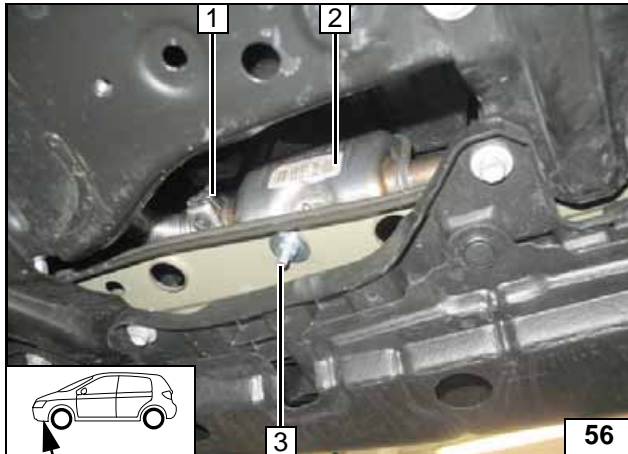
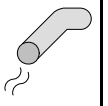

Ensure sufficient distance to neighbouring components.

- 1 Exhaust-pipe hose clamp
- 2 Exhaust muffler
- 3 M6x20 bolt, large diameter washer, angle bracket, flanged nut, original vehicle hole



Installing exhaust muffler

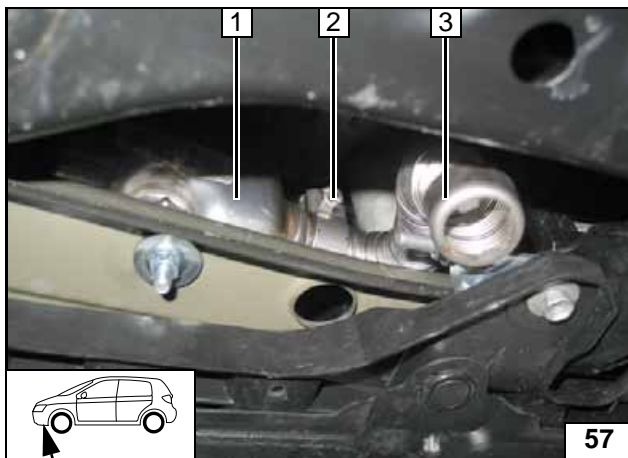

Ensure sufficient distance to neighbouring components.

- 1 Exhaust muffler
- 2 Hose clamp
- 3 Exhaust end section



Installing exhaust end section

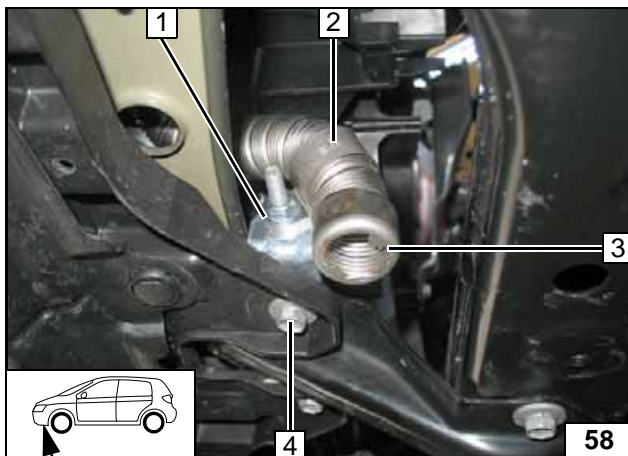

Ensure sufficient distance to neighbouring components.

- 1 Angle bracket
- 2 Pipe clamp, M6x20 bolt, flanged nut
- 3 Exhaust end section
- 4 Original vehicle bolt



Installing exhaust end section

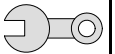

Final Work

WARNING!

Reassemble the disassembled components in reverse order.

Check all hoses, clamps and all electrical connections for firm seating.

Secure all loose cables using cable ties.

Only use manufacturer-approved coolant.

Spray the heater components with anti-corrosion wax (Tectyl 100K, Order No. 111329).

- Connect the battery
- Fill and bleed the coolant circuit according to the vehicle manufacturer's specifications.
- Set the digital timer.
- Make settings on A/C control panel according to the "Operating Instructions for End Customer".
- Check the proper operation of the parking heater, see the operating instructions/installation instructions.
- Mount information label "Switch off parking heater before refueling" in area of filler neck.

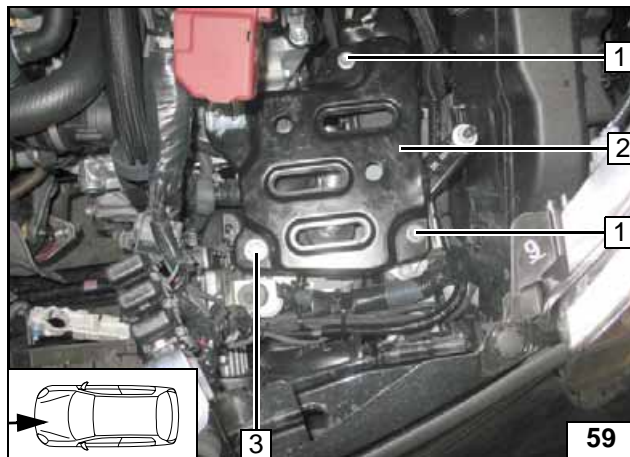

Install battery carrier plate **2** with M8x40 bolt, large diameter washer **3** and strut.

1 Original vehicle bolt [2x]

**Installing
battery car-
rier plate**

Webasto
Feel the drive

Webasto AG
Postfach 80
D-82131 Stockdorf / Germany
National Hotline: 01805 93 22 78
(14 Cent aus dem deutschen Festnetz)
Hotfax: 0395 5592 353
Hotmail: hotline@webasto.de
<http://www.webasto.de>

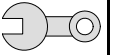

Template for Fuel Sender

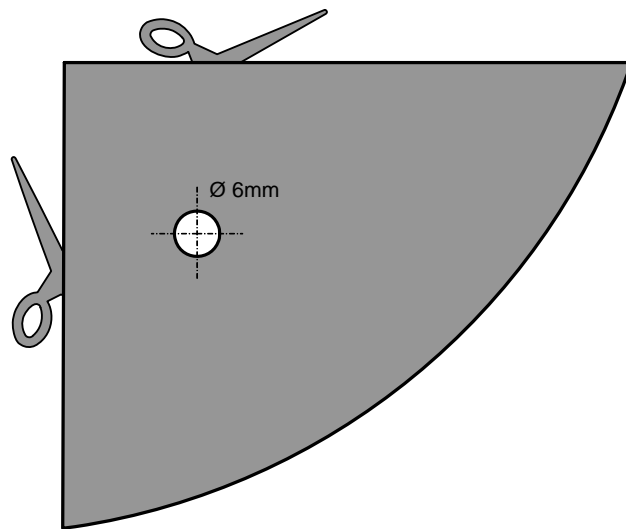

100 mm



Scale 1:1

Compare the size of the printed version with dimension lines.

Permitted tolerance a maximum of 2%.

Set the printer settings to "no margin" or "minimise margins" and 100% of the normal size.

100 mm

0

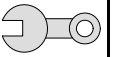

Template for fuel standpipe

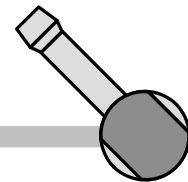
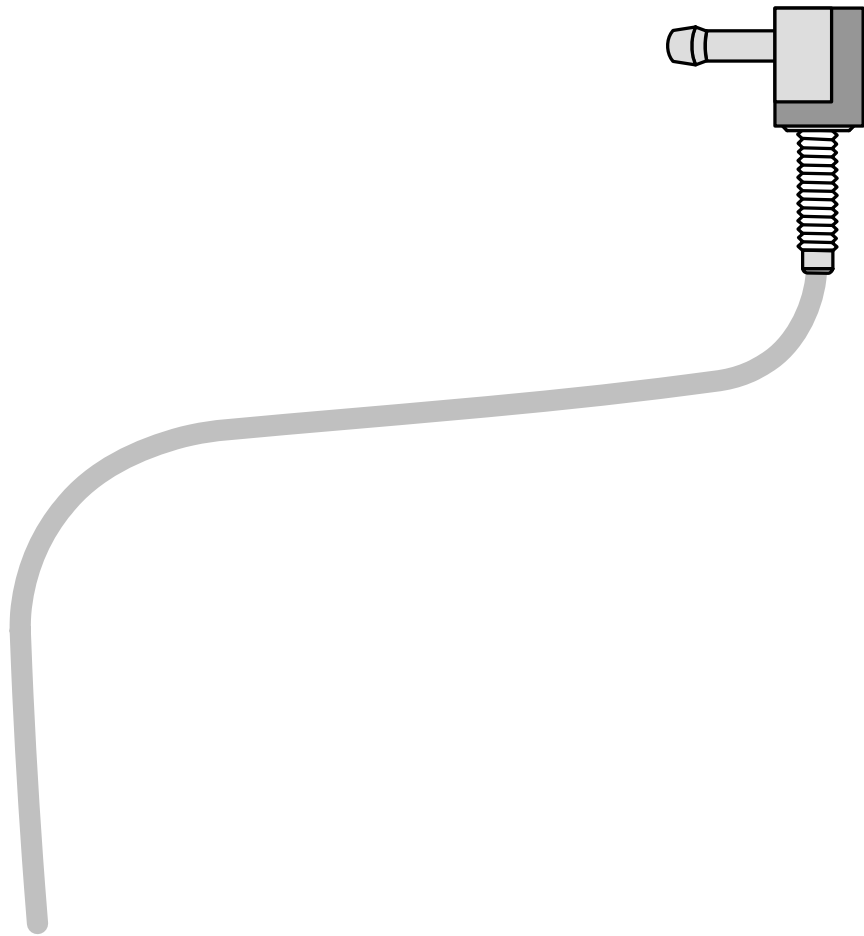

100 mm



Scale 1:1

Compare the size of the printed version with dimension lines.
Permitted tolerance a maximum of 2%.

Set the printer settings to "no margin" or "minimise margins" and 100% of the normal size.

100 mm

0

Operating Instructions for End Customer

Please remove page and add to the vehicle operating instructions.

Note:



We recommend matching the heating time to the driving time.

Heating time = driving time

Example:

For a driving time of approx. 20 min. (in one direction), we recommend not exceeding a switch-on time of 20 min.

On vehicles with passenger compartment monitoring, this must be deactivated during heating!

If the summer/winter switch option has been installed, this must be switched in accordance with the time of year. The heater will then only switch on the vehicle fan to ventilate the vehicle interior in the position Winter  heat and in the position Summer .

Before parking the vehicle, make the following settings:



Note:

The display of the A/C control panel is not active during heater operation!

- 1 Set temperature to "HI"
- 2 Set fan to level "1" or max. "2"
- 3 Air outlet to windshield



- 1 Set fan to level "1" or max. "2"
- 2 Air outlet to windshield
- 3 Set temperature to "max."



Automatic air-conditioning

Manual air-conditioning