

Water Heater Unit



Thermo Top C Additional Heater e1 00 0002

Installation documentation

Toyota Prius Hybrid

1.8 Gasoline

from Model Year 2010

Left-hand drive vehicle

Automatic air-conditioning



WARNING!

Hazard warning:

Incorrect installation or repair of Webasto heating systems may cause a fire or result in the emission of carbon monoxide, which can be fatal. Serious or fatal injuries can be caused as a result.



Specialist company training, technical documentation, specialized tools and equipment are required to install and repair Webasto heating and cooling systems. Only original Webasto parts must be used. For this, also see the catalog of air and water heater unit accessories from Webasto.

NEVER attempt to install or repair Webasto heating or cooling systems if you have not successfully completed the company training and thereby acquired the required technical skills, or if you do not have access to the required technical documentation, tools and equipment needed to carry out correct installation and repairs.

ALWAYS follow all Webasto installation and repair instructions and observe all warnings.

Webasto does not accept any liability for defects and damage that are attributable to installation by untrained staff.

Table of Contents

Validity	2	Preparing installation location	12
Heater Unit/Installation Kit	3	Installing heater unit	13
Foreword	3	Exhaust gas	14
General Instructions	3	Combustion air	16
Special Tools	3	Fuel	17
Explanatory Notes on Document	4	Coolant circuit	20
Preliminary Work	5	Final Work	23
Heater unit installation location	5	Template for fuel standpipe	24
Preparing electrical system	6	Operating Instructions for End Customer	25
Electrical system	7		
Fan controller	8		
Digital timer	11		
Remote option (Telestart)	11		

Validity

Manufacturer	Model	Type	EG-BE No./ABE
Toyota	Prius Hybrid	XW3 (A)	e11 * 2001 / 116 * 0264 * ...

Engine type	Engine model	Output in kW	Displacement in cm ³
2ZR-FXE	Gasoline	73	1798

Vehicle and engine types, equipment variants and national specifications not listed in this installation documentation have not been tested. However, installation according to this installation documentation may be possible.

The installation location of the digital timer should be confirmed with the end customer before installation.

Heater Unit/Installation Kit

Quantity	Description	Order No.:
1	Delivery scope Toyota Prius <i>Thermo Top C</i> (Undervoltage protection 11.0 V)	1315474A
1	Heater control	See price list

The following must be additionally ordered from Toyota:

The following components are installed in accordance with the special Toyota installation documentation.

Quantity	Description	Toyota Order No.:
1	Load status indicator	DENG5-56380-37
1	Charger XS3600 (optional)	DENG5-XS360-37

Foreword

This installation document applies to vehicles Toyota Prius Hybrid 1.8 Gasoline - for validity, see page 2 - from model year 2010 and later, assuming technical modifications to the vehicle do not affect installation, any liability claims excluded. Depending on the vehicle version and equipment, modifications may be necessary during installation with respect to this installation documentation.

However, where this is the case the stipulations in this "installation documentation" and "operating and maintenance instructions" for the *Thermo Top C* should be observed.

The corresponding rules of technology and any information from the vehicle manufacturer should be observed during the installation work.

General Instructions

Installation should be carried out according to the general, standard rules of technology. Unless specified otherwise, fasten hoses, lines and wiring harnesses to original vehicle lines and wiring harnesses using cable ties.

Sharp edges should be fitted with edge protectors (split-open plastic hose).

Spray unfinished body areas, e.g. drilled holes, with anti-corrosion wax (Tectyl 100K, Order No. 111329).

Special Tools

- Torque wrench for 2.0 - 10 Nm
- Hose clamping pliers
- Metric thread-setter kit

Explanatory Notes on Document

To provide you with a quick overview of the individual working steps, you will find an identification mark on the outside top right corner of the page in question.

Mechanical system

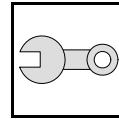

Electrical system

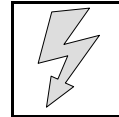

Coolant circuit

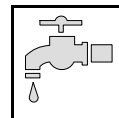

Fuel

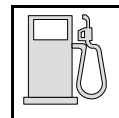

Exhaust gas

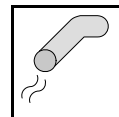

Combustion air

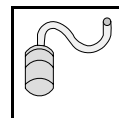

Software

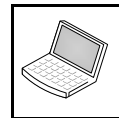

Special features are highlighted using the following symbols:



Specific risk of injury or fatal accidents.



Specific risk of damage to components.



Specific risk of fire or explosion.



Reference to general installation instructions of Webasto components or to the manufacturer's vehicle-specific documents.



Reference to a special technical feature.

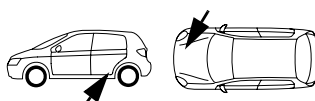

The arrow in the vehicle icon indicates the position on the vehicle and the viewing angle.

All dimensions are in mm!
Tightening torque of hose clamps = 2.0 + 0.5 Nm!
Tightening torque of Ejet screws, Ejet studs = 10 Nm!

Preliminary Work

WARNING!

- Open the fuel tank cap, ventilate the tank.
- Close the tank cap again.
- Disconnect the battery "earth" or "ground" connection.
- Depressurize the cooling system.
- Copy the factory number from the original type label to the duplicate type label.
- Remove years that do not apply from the duplicate label.
- Attach the duplicate label (type label) in the appropriate place.
- Remove the left-hand wheel well trim.
- Remove the bumper.
- Remove the rear bench seat
- Open the left fuel sender service lid.
- Remove the fuel-tank sending unit in accordance with the manufacturer's specifications
- Remove the underride protection of the engine
- Remove the trim at the underbody of the spare wheel
- Remove the trim at the underbody of fuel lines
- Remove the glove compartment
- Remove the center console trim in the driver's side footwell
- Remove the footwell trim on the driver's and front passenger side.

Remove page 25 "Operating Instructions for End Customer" and add to the vehicle operating instructions.



Heater unit installation location

1 Heater unit

Installation location

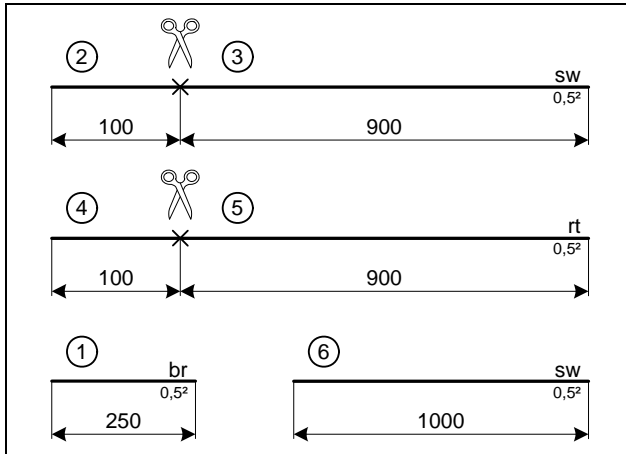

Preparing electrical system

Electrical system in the passenger compartment

Pull black wire section 6 into protection sleeving.

Cutting wires to length

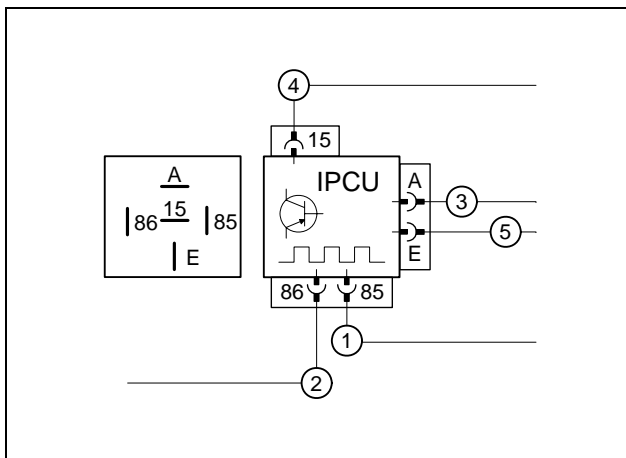

Connect wires to IPCU.

IPCUC view on the contact side

Pull black (sw) wire section 3 and red (rt) wire section 5 into protective sleeving.



Pre-mounting IPCU

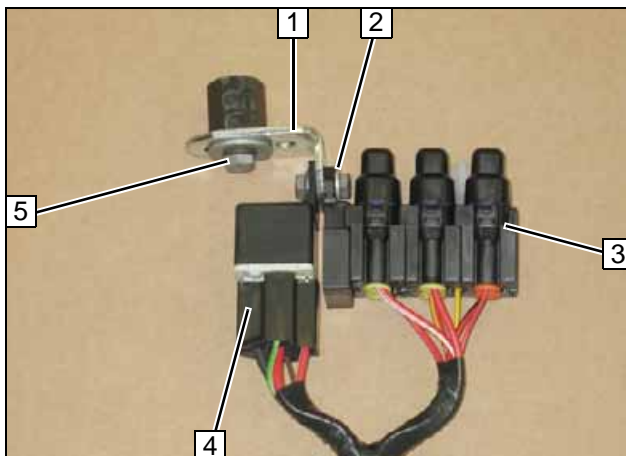

- 1 Angle bracket
- 2 M5x12 bolt, large diameter washer, retaining plate for fuse holder, flanged nut
- 3 Fuses F1-3 mounted
- 4 K3 relay
- 5 M6x12 bolt, spring lockwasher, large diameter washer, 20 spacer nut

Preassembling fuse holder



Electrical system

Positive wire

Crimp the tab receptacle at the positive wire 1 and insert it into the free socket B+/30.

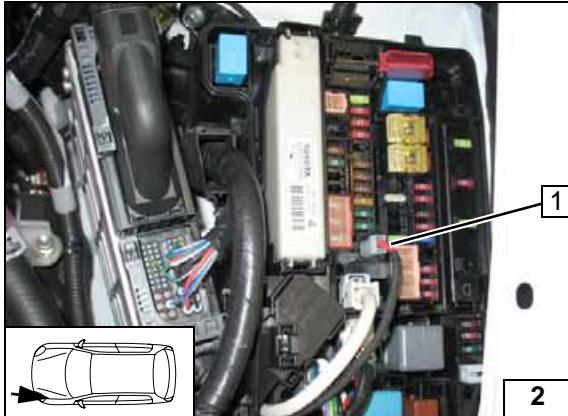

Wiring harness pass through

- 1 Protective rubber plug
- 2 Wiring harness of heater unit, heater control

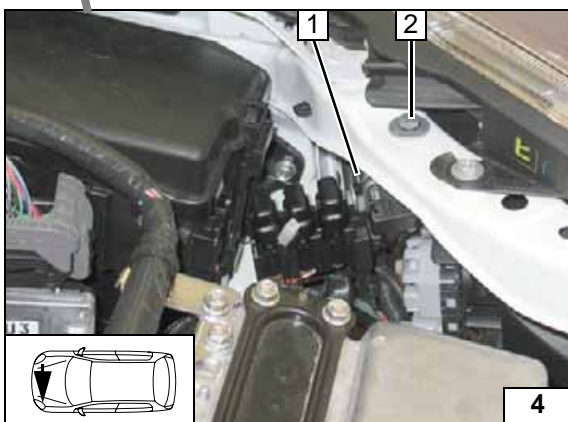
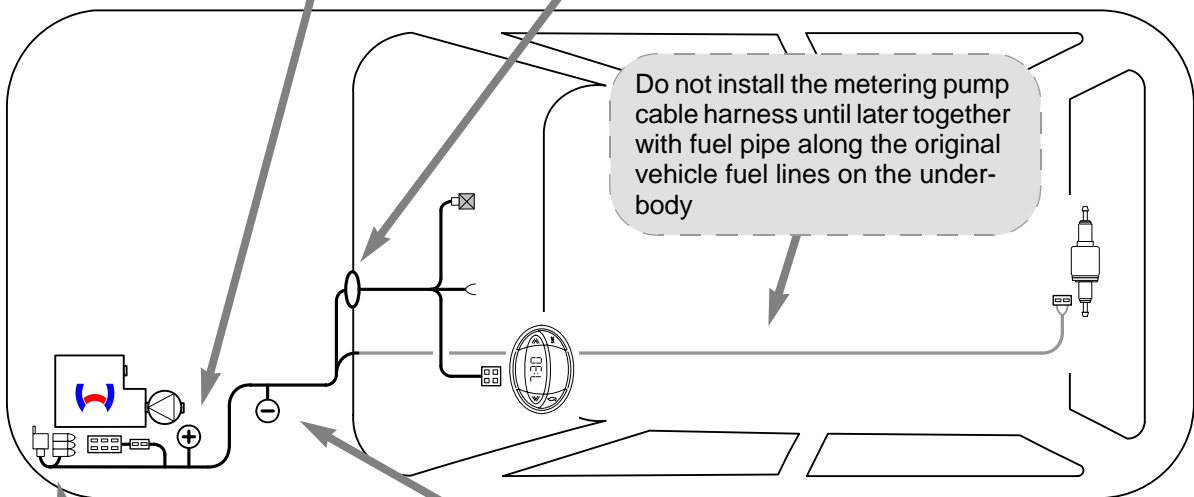
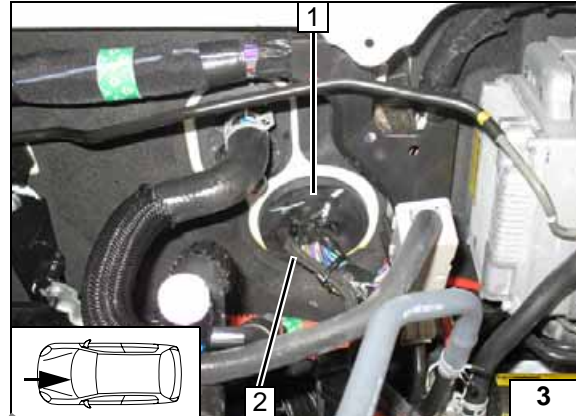

Fuse holder, K3 relay

- 1 Angle bracket
- 2 M6x12 bolt, spring lockwasher, large diameter washer, existing hole

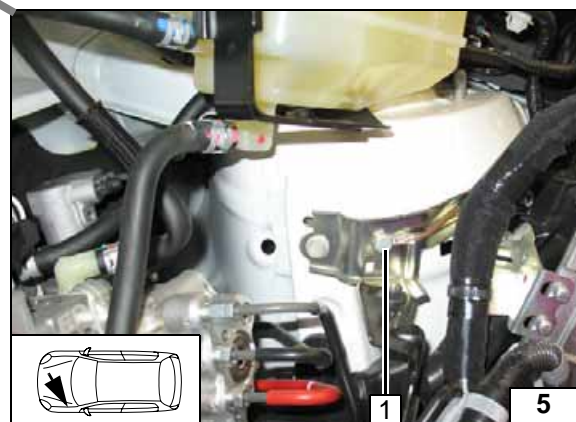

Ground wire

Ground wire 1 with M6x12 bolt on original vehicle ground support point



Wiring harness installation diagram



Fan controller

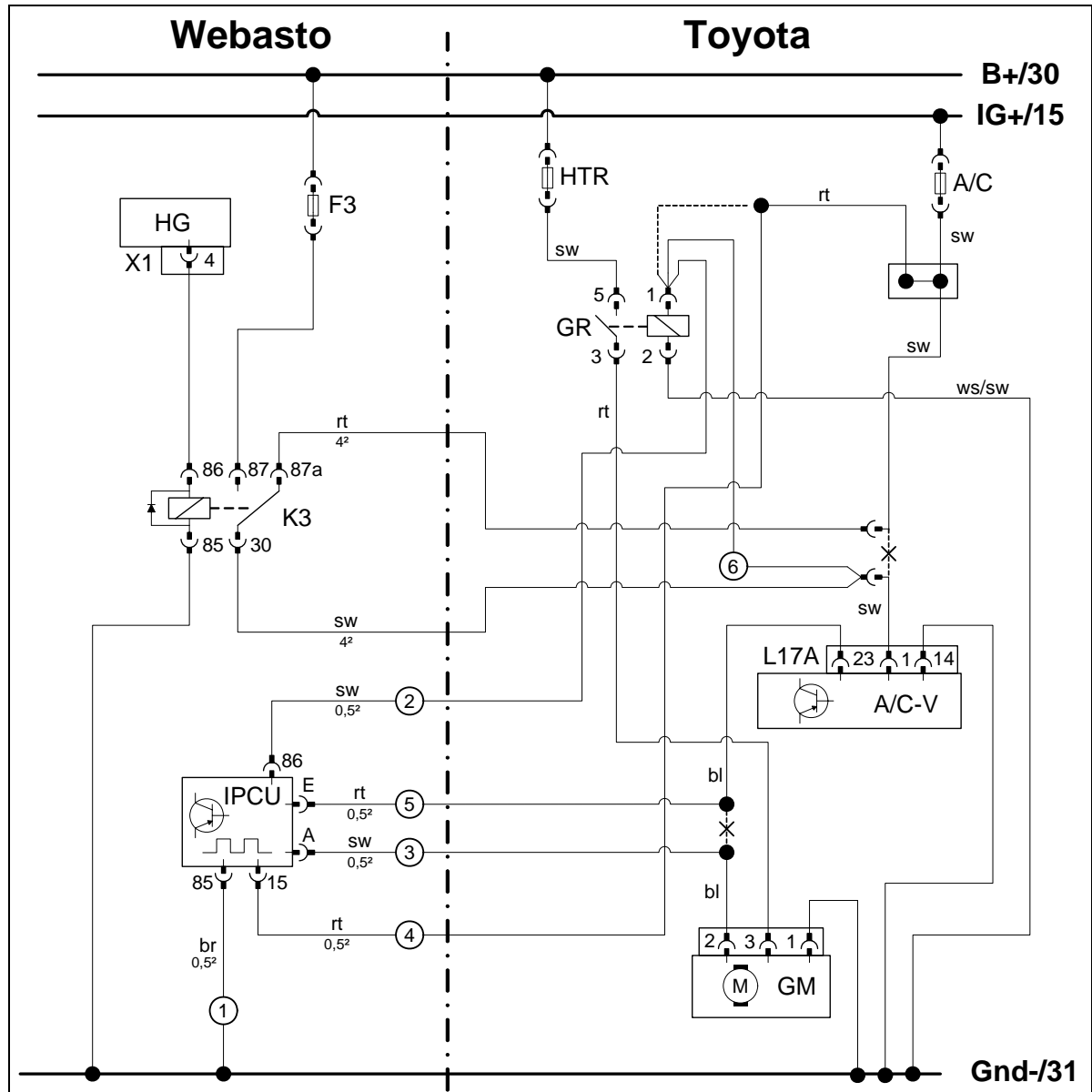

Wiring diagram

Webasto components		Vehicle components		Colors and symbols	
HG	Heater unit TT-C	HTR	50A fuse	rt	red
X1	6-pin heater unit connector	A/C	10 A fuse	sw	black
F3	10 A fuse	gr	Fan relay L104	ge	yellow
K3	Fan relay	A/C-V	A/C booster	gn	green
IPCU	Pulse width modulator	GM	Fan motor L33	bl	blue
				ws	white
				br	brown
IPCU adjustment values:					
Duty cycle: 60%					
Frequency: 400 Hz					
Voltage: 10 V					
Function: Low-side					
				X	Cutting point
Wiring colors may vary.					

Legend

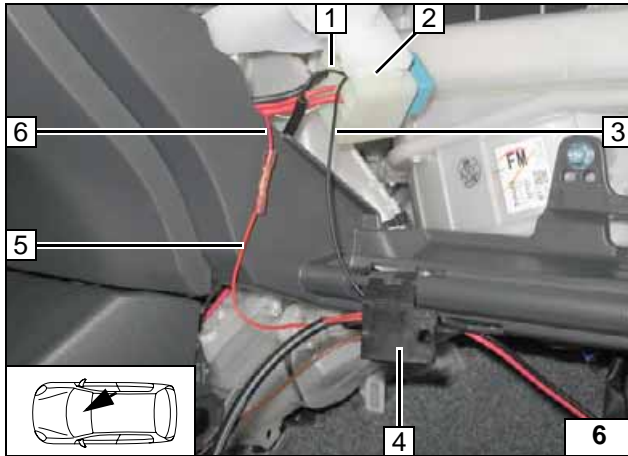
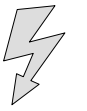

Connect to the fan relay. Pull red wire **6** from the base of fan relay **2** pin 2. Lay black wire **⑥ 1** of the A/C booster. Produce connections as shown in wiring diagram.

- 3** Black (sw) wire of IPCU/86
- 4** Base of IPCU
- 5** Red (rt) wire of IPCU/15



Con-nection for IPCU

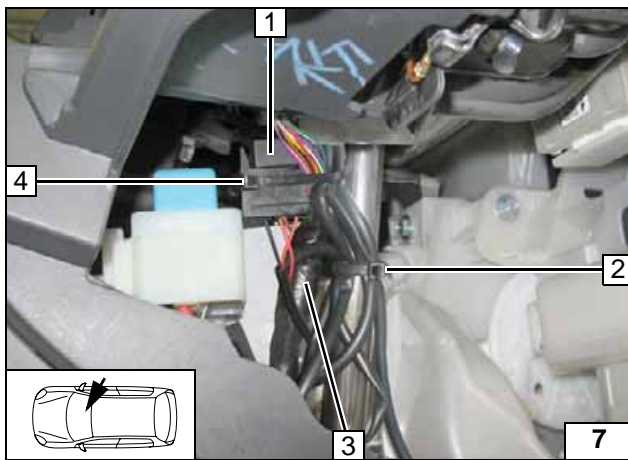

Fix IPCU **1** on the original vehicle wiring harness **3** with cable tie **2**.

- 2** Cable tie



Installing IPCU

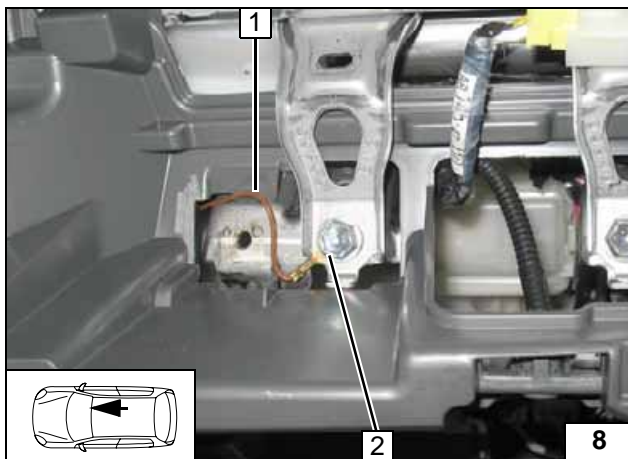

Produce connections as shown in wiring diagram.

- 1** Brown (br) IPCU/85, cable lug 8
- 2** Original vehicle bolt



Ground connection for IPCU

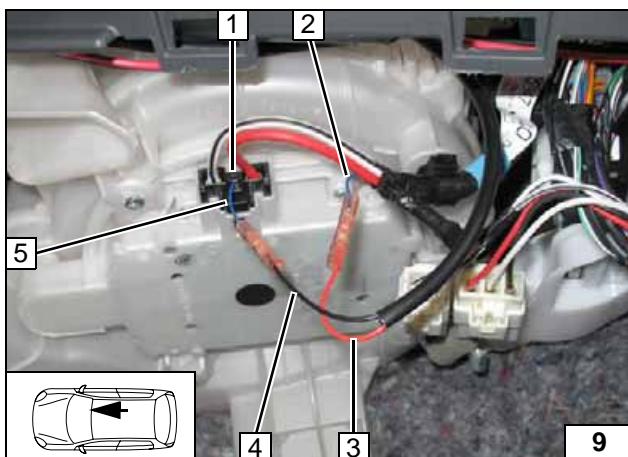

Connection to 3-pin connector **1** from the blower motor. Produce connections as shown in wiring diagram.

- 2** Blue (bl) wire of A/C booster
- 3** Red (rt) wire of IPCU/E
- 4** Black (sw) wire of IPCU/A
- 5** Blue (bl) wire fan motor connector pin 2



Con-necting fan-motor

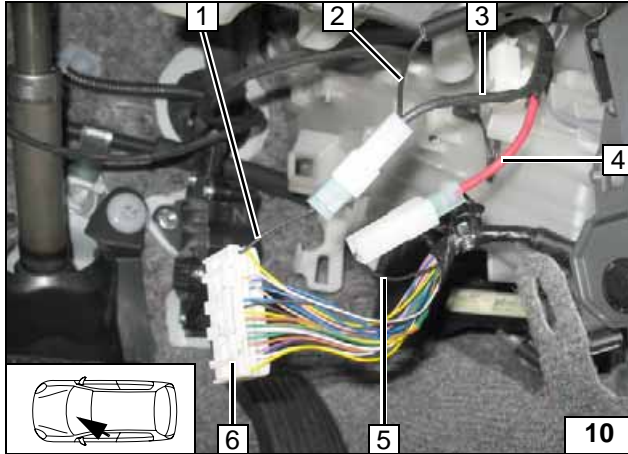
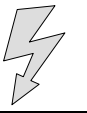

Connect to the 40-pin connector L17A 6 of the A/C booster.
Produce connections as shown in wiring diagram.

- 1 Black (sw) wire of 40-pin connector L17A pin 1
- 2 Black (sw) wire Ⓢ of fan relay pin 2
- 3 Black (sw) wire of K3/30
- 4 Red (rt) wire of K3/87a
- 5 Black (sw) wire of fuse A/C



Con-necting the A/C booster

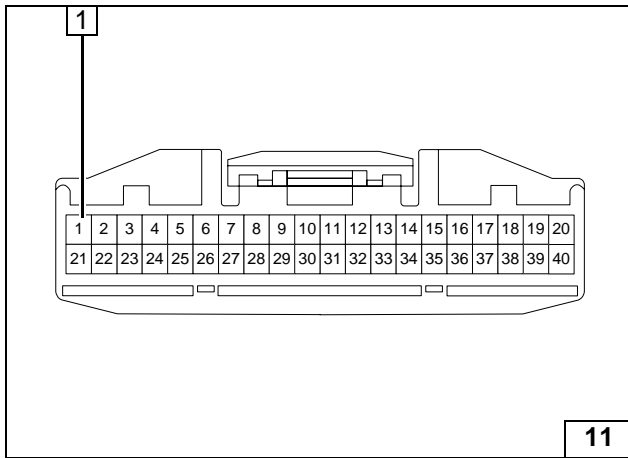

- 1 Connector L17A on contact side pin 1

Connector L17A

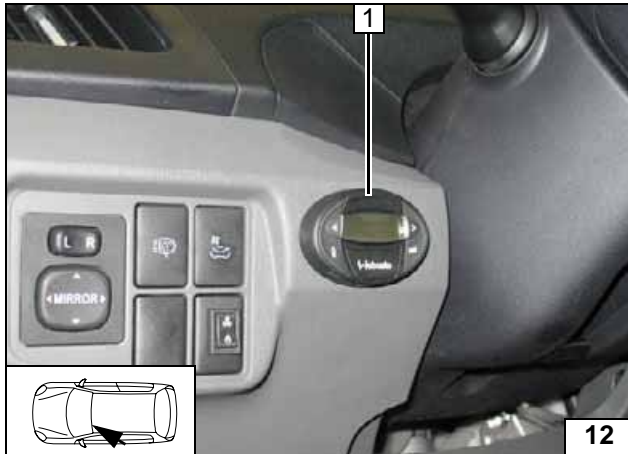

Digital timer

1 Digital timer



Installing digital timer

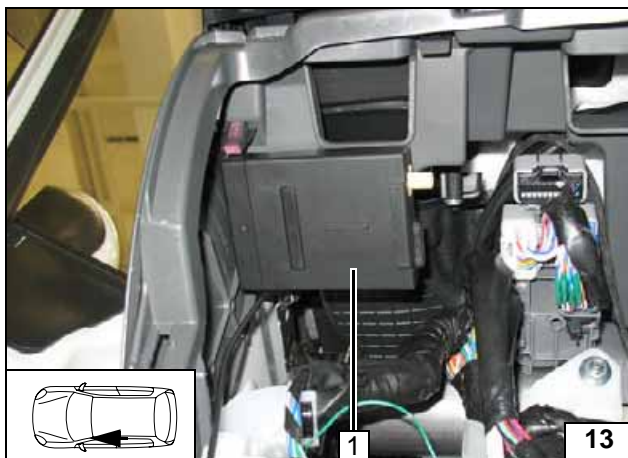

Remote option (Telestart)

Fasten receiver 1 with adhesive tape.



Installing receiver

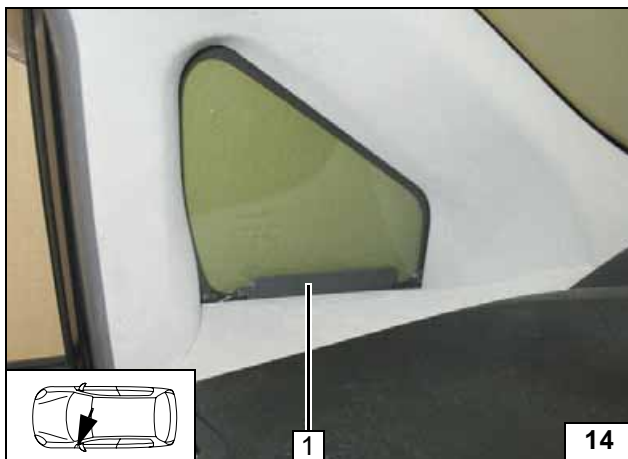

1 Antenna

Installing antenna

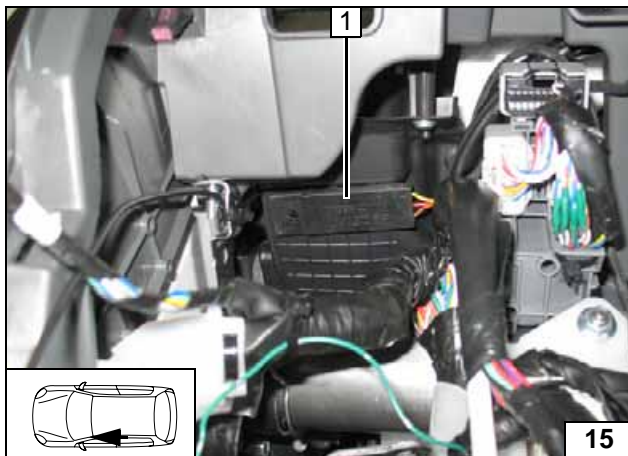

Temperature sensor HTM100

Fasten temperature sensor 1 with adhesive tape.



Installing temperature sensor

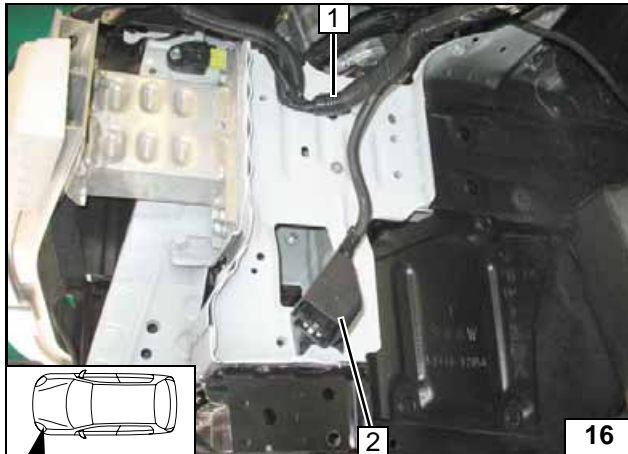
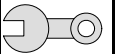

Preparing installation location

Unclip original vehicle wiring harness at position 1. Unclip the connector of front fog light / blinker 2.



Preparing installation location

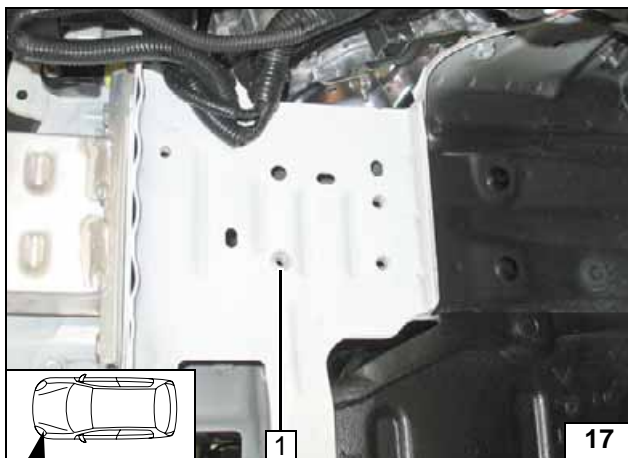

1 Rivet nut, existing hole

Installing rivet nut

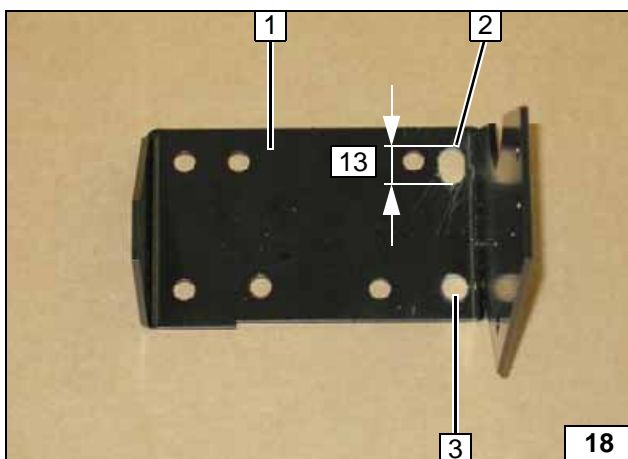

- 1 Bracket
- 2 Oblong hole 8.5x13
- 3 8.5 mm dia. hole

Preparing bracket

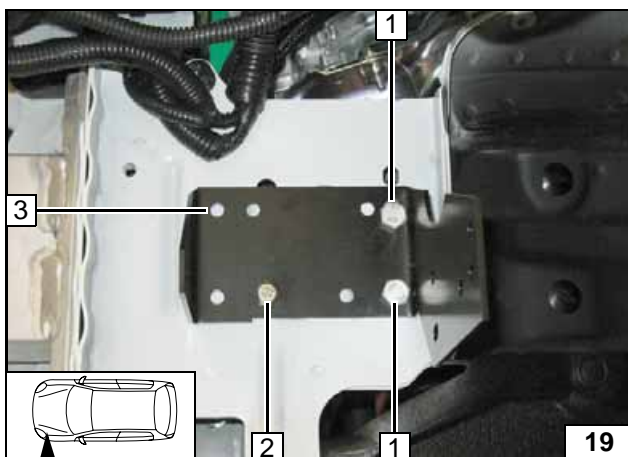

Loosely mount bracket

- 1 M8x20 bolt, existing threaded hole [2x]
- 2 M6x20 bolt
- 3 Copy hole pattern



Copying hole pattern

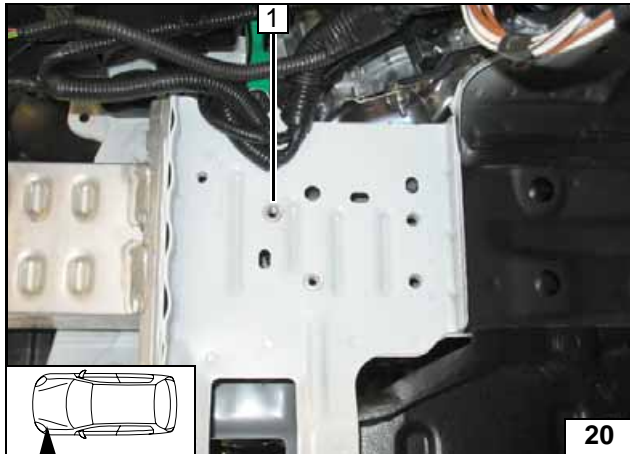
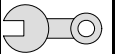

Remove the bracket.

- 1 9.1 mm dia. hole; rivet nut



Installing rivet nut

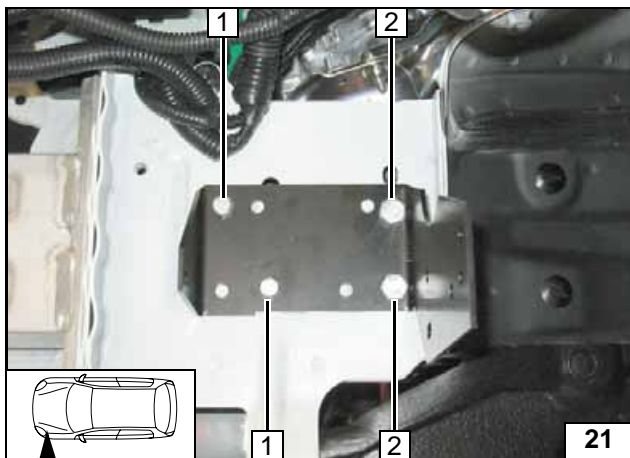

Insert one washer each between the bracket and the body at position 2.

- 1 M6x20 bolt, spring lockwasher [2x each]
- 2 M8x20 bolt, spring lockwasher, washer [2x each]



Copying hole pattern

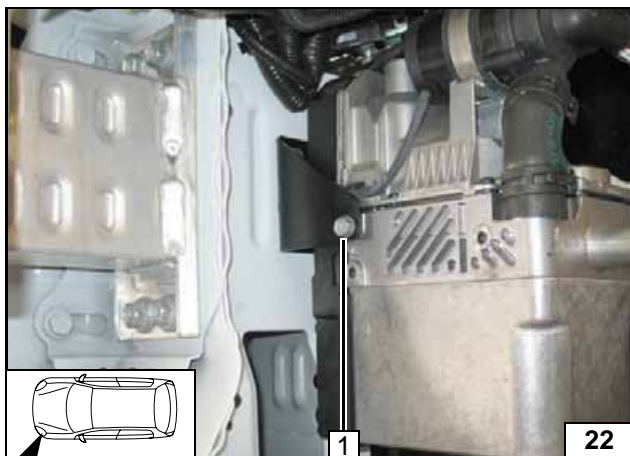

Installing heater unit

Connect wiring harness for heater unit before installation.

- 1 E-jot screw



Installing heater unit

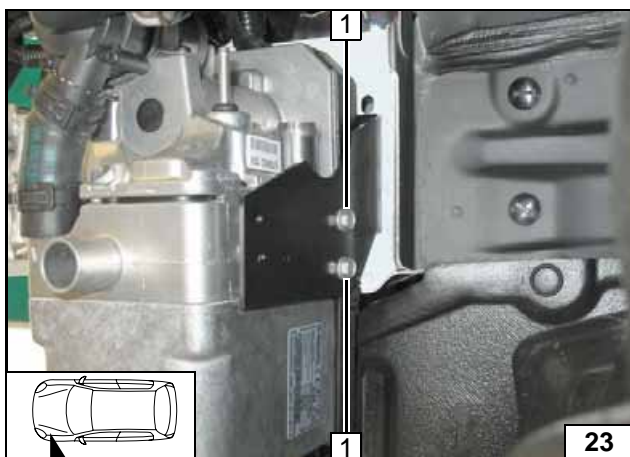

- 1 E-jot screw [2x]

Installing heater unit

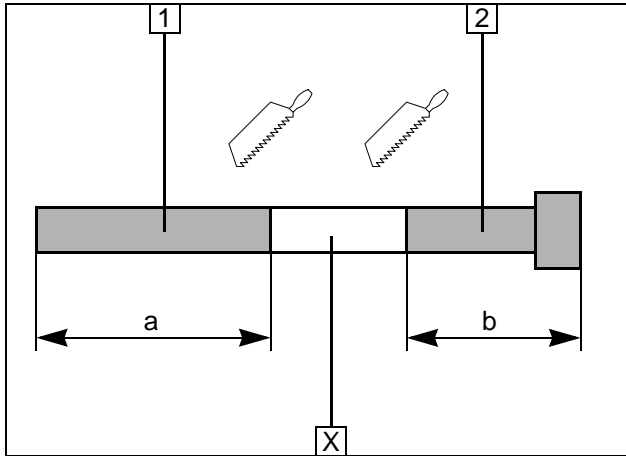
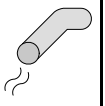

Exhaust gas

Discard section X.

- 1 Exhaust pipe
a = 350
- 2 Exhaust end section
b = 280



Preparing exhaust pipe

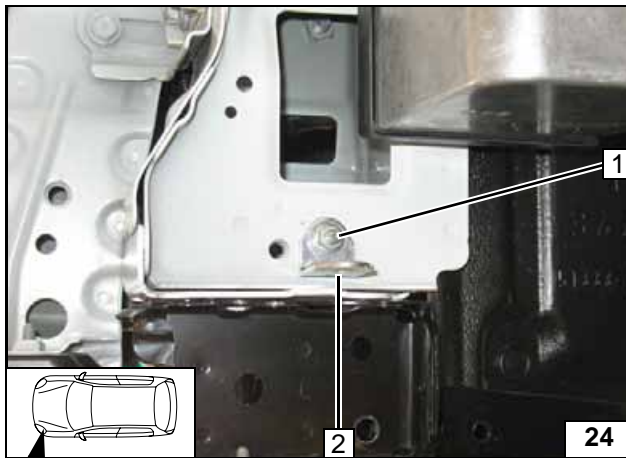

- 1 M6x20 bolt, large diameter washer, flanged nut, existing oblong hole
- 2 Angle bracket

Installing angle bracket

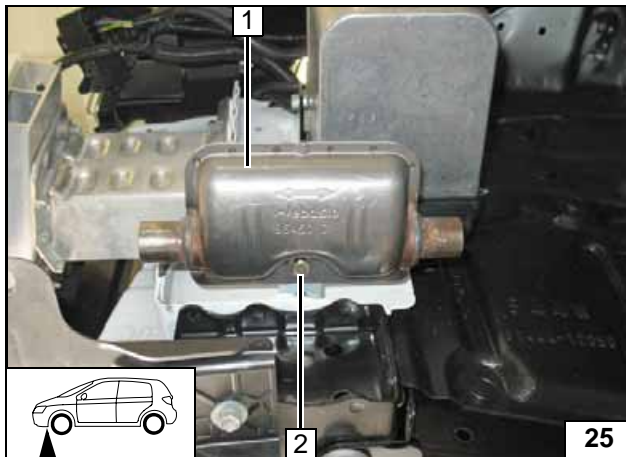

- 1 Muffler
- 2 M6x20 bolt, flanged nut

Installing muffler

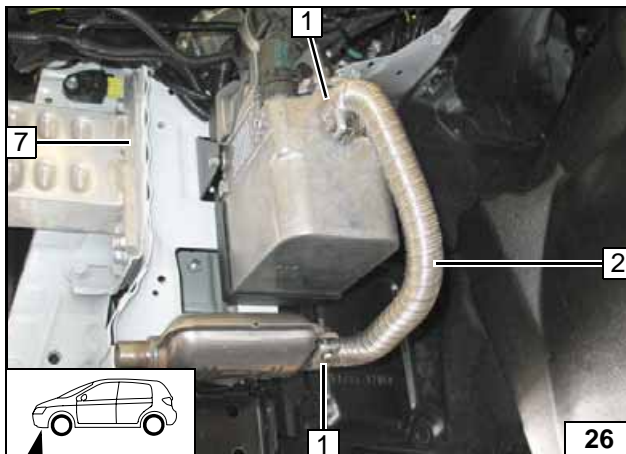

- 1 Hose clamp [2x]
- 2 Exhaust pipe

Installing exhaust pipe

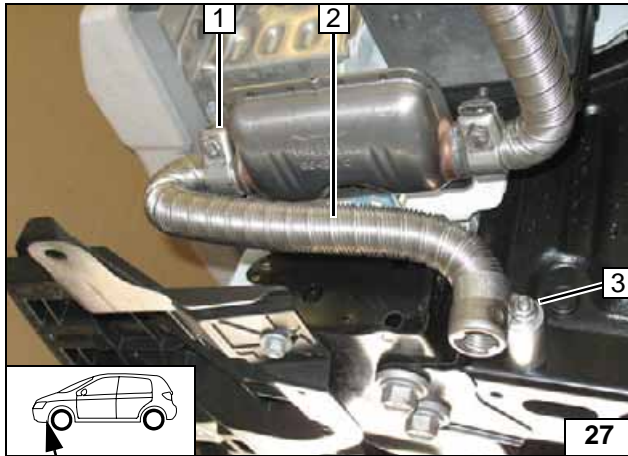
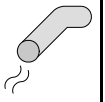

- 1 Hose clamp
- 2 Exhaust end section
- 3 M6x55 bolt, 40 mm shim, p-clamp, flanged nut, existing hole

Installing exhaust end section

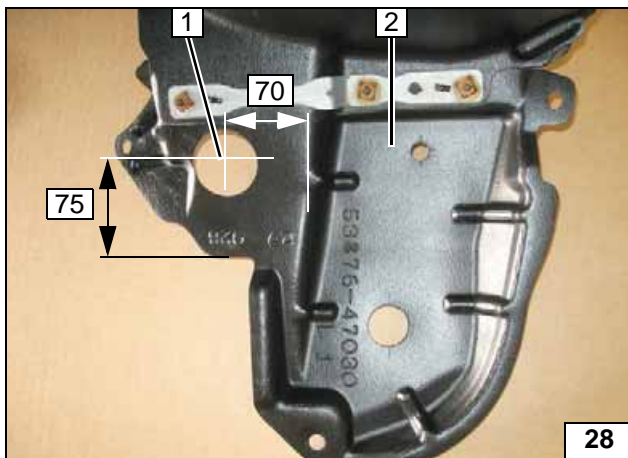

- 1 55 mm dia. hole
- 2 Wheel well trim

Cutting out wheel well trim

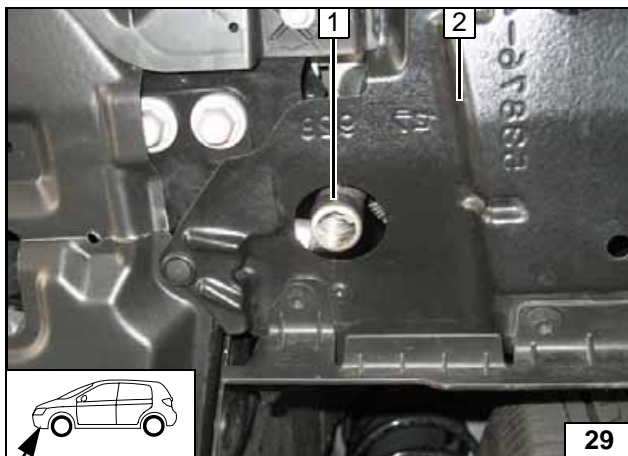

Mount wheel well trim 2. Align exhaust end section 1 at the center in the hole.



Aligning exhaust end section

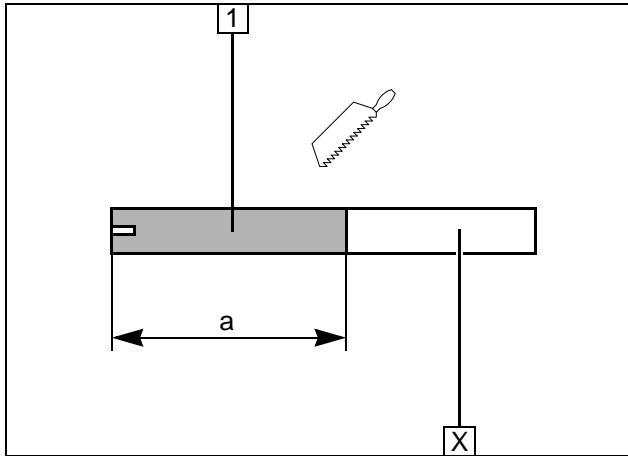
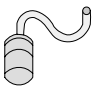

Combustion air

Discard section X.

- 1 Combustion air pipe
a = 140



Cutting combustion air pipe to length

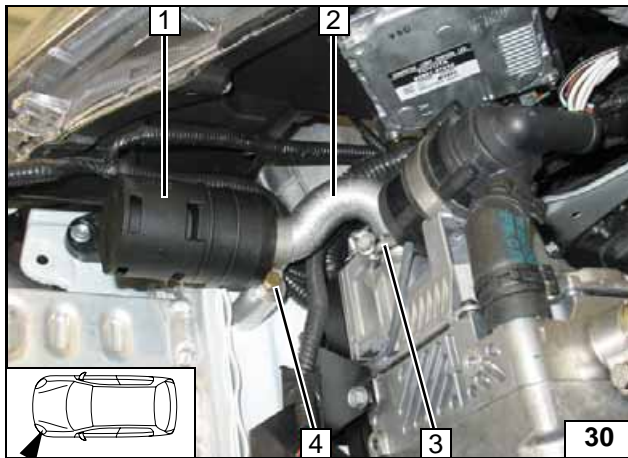

- 1 Muffler
- 2 Combustion air pipe
- 3 27 mm dia. clamp
- 4 M6x55 bolt, p-clamp, 40 mm shim, existing threaded hole



Installing muffler



Fuel

CAUTION!

Open the vehicle's fuel tank cap, ventilate the tank and then re-close the tank lock.

Catch any fuel running off with an appropriate container.

Install fuel line and metering-pump wiring harness so that they are protected against stone impact. Unless specified otherwise, always fasten using cable ties. Mount the fuel line and wiring harness with rub protection on sharp edges.

WARNING!

The fuel line and wiring harness are routed to the metering pump in as shown in the wiring harness routing diagram.

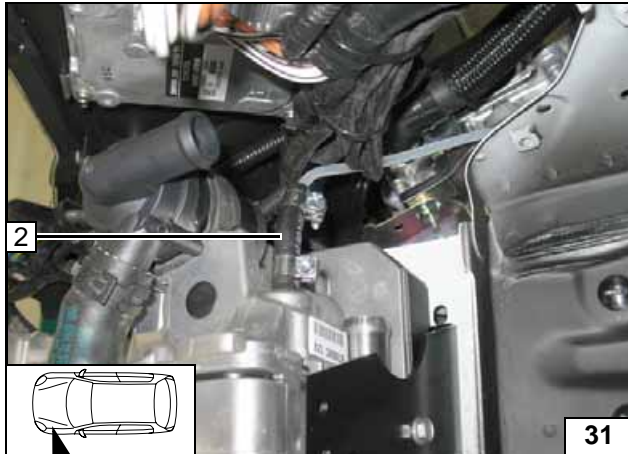

- 1 Fuel line
- 2 Hose section, 10 mm dia. clamp [2x]

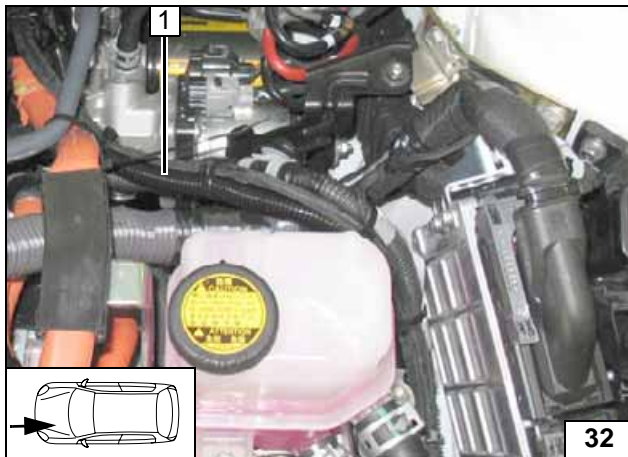

Route the fuel line in corrugated tube 1 to the firewall and further along the underbody.



Route fuel line and wiring harness of metering pump 1 along original vehicle fuel lines to installation location of metering pump.



Connect-
ing heater
unit



Install-
ing
lines



Install-
ing
lines

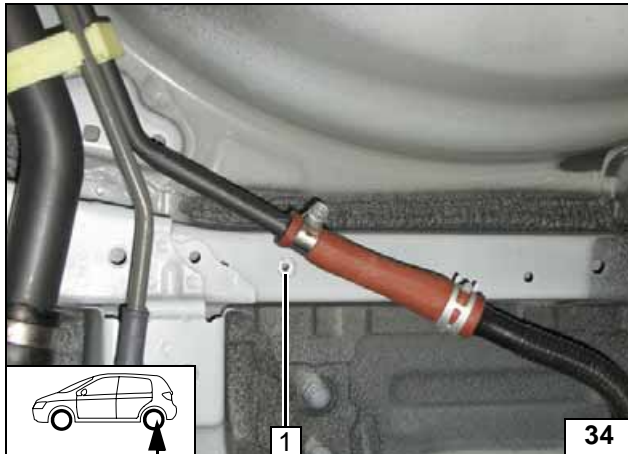

1 Rivet nut, existing hole

Installing rivet nut

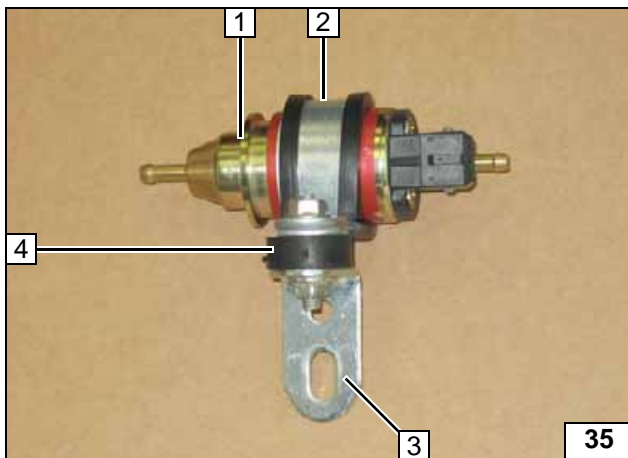

1 Metering pump
2 Rubber-coated pipe clamp
3 Angle bracket
4 Silent block, flanged nut [2x]

Pre-mounting metering pump

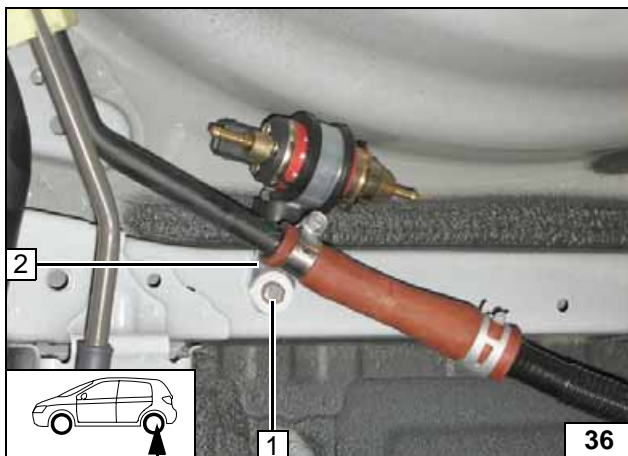

1 M6x20 bolt, spring lockwasher, large diameter washer
2 Angle bracket

Installing metering pump

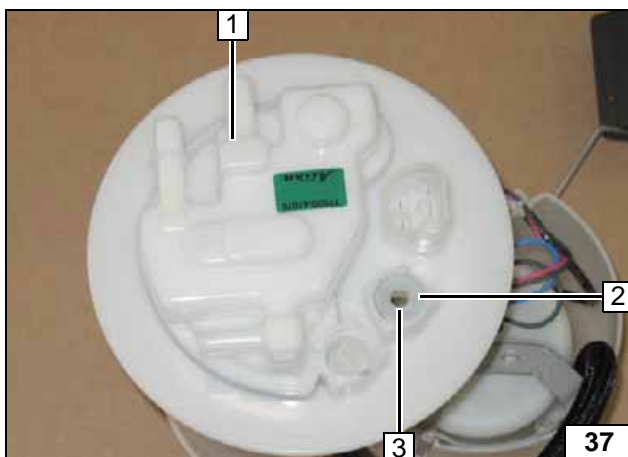

Remove fuel-tank sending unit 1 in accordance with manufacturer's specifications.

2 Washer dia. $d_a = 17.8$
3 Copy hole pattern, 6 mm dia. hole

Removing fuel



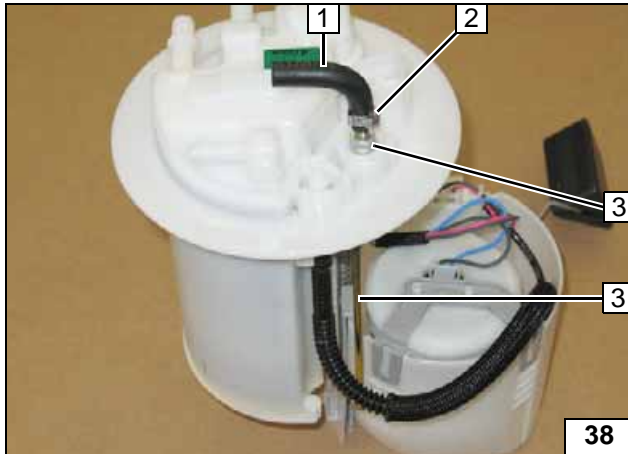

Shape fuel standpipe **3** according to template, cut to length, install and align.
Cut the 90° molded hose **1** at 3.5 dia. by 10 mm.

2 8 mm dia. Caillau clamp



Installing fuel standpipe

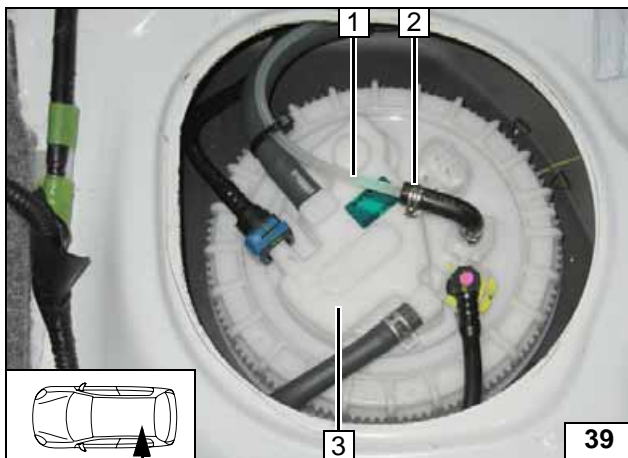

Install fuel-tank sending unit **3** in accordance with manufacturer's instructions.

1 Fuel line
2 10 mm dia. Caillau clamp



Connecting fuel line

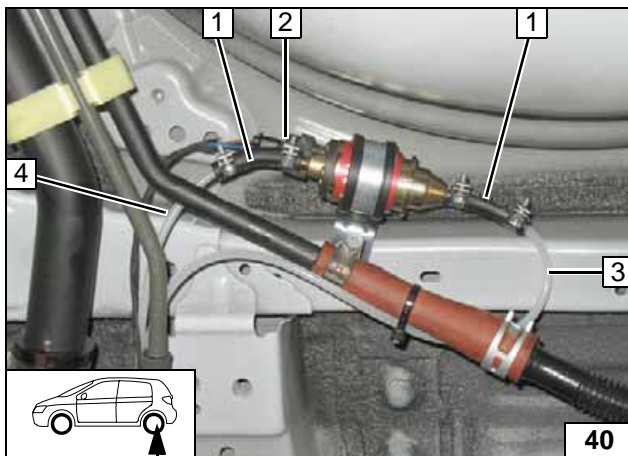

Check the position of the components; adjust if necessary. Check that they have free clearance.

1 Hose section [2x], 10 mm dia. clamp [4x]
2 Wiring harness of metering pump, connector mounted
3 Fuel line of fuel standpipe
4 Fuel line of heater unit



Connecting metering pump

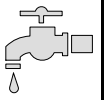



Coolant circuit

WARNING!

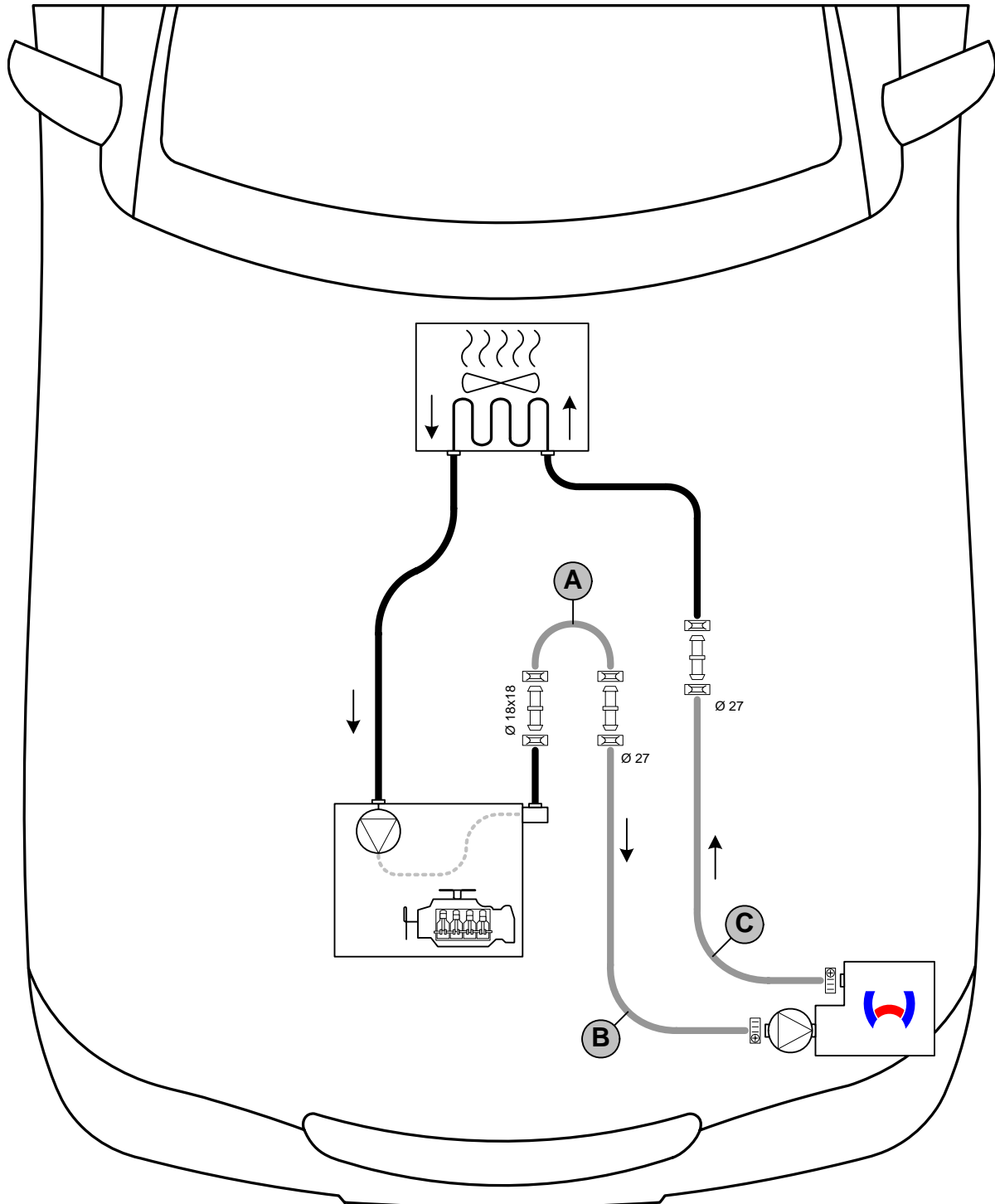
Any coolant running off should be collected using an appropriate container! Install hoses so that they are kink-free. Unless specified otherwise, always fasten using cable ties. Position clamps so that no other hose can be damaged! When installing the hoses, the heater unit must be filled with coolant. The connection should be "inline" based on the following diagram:



Hose routing diagram

All spring clips without a specific designation  = 25 mm dia.
 All hose clamps without a specific designation  = 20-27 mm dia.
 All connecting pipes without a specific designation  = dia. 18x20.



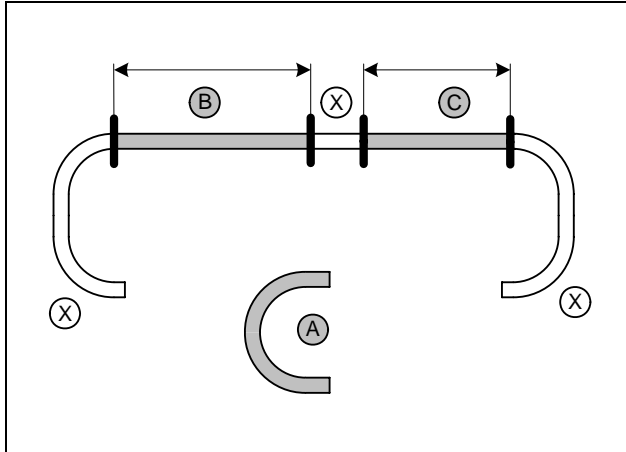
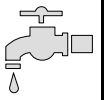

Discard section **X**.
Hose **A** = 180° molded hose, 18x18

B = 930
C = 930



Cutting coolant hoses to length

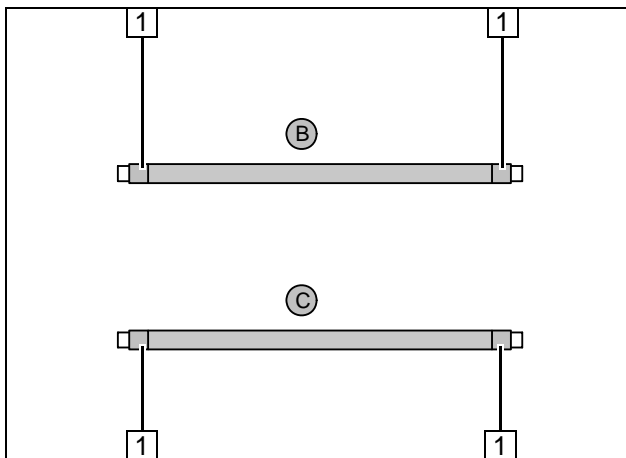

Push braided protection hose onto hose **B** and **C** and cut to length.
Cut heat shrink plastic tubing to length.

1 50 mm long heat shrink plastic tubing [4x]



Preparing coolant hoses

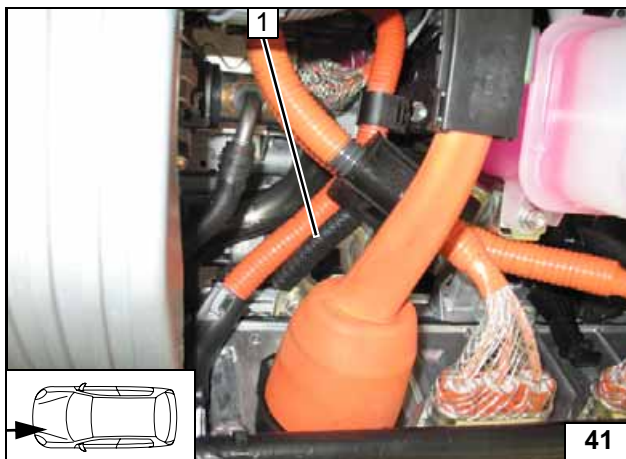

1 50 mm edge protection

Inserting edge protection

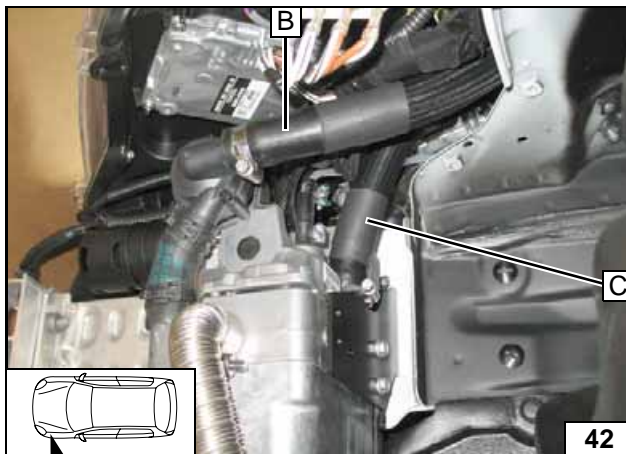

Connecting heater unit

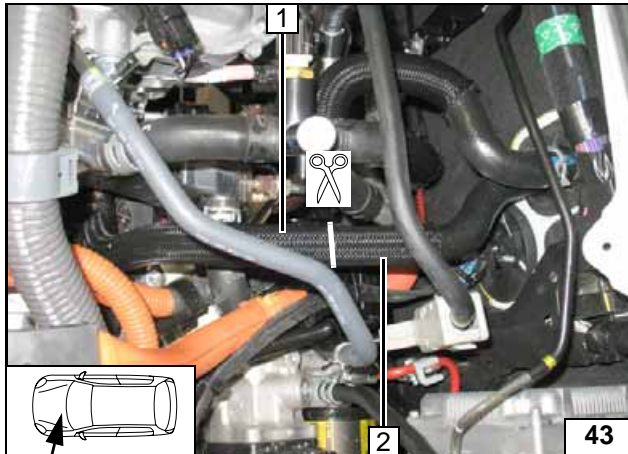

- 1 Engine-outlet hose section
- 2 Hose section of heat exchanger inlet

Cutting point

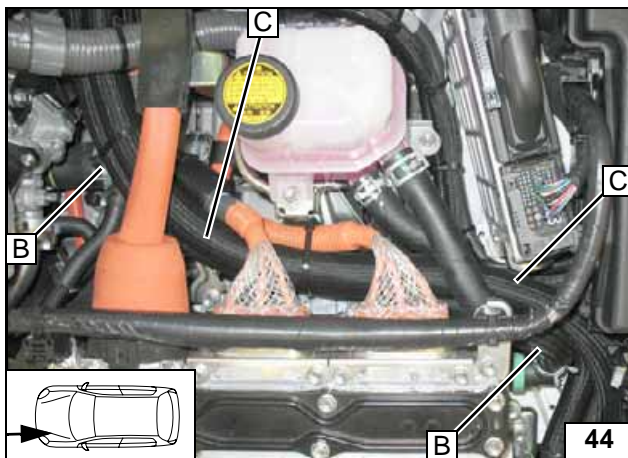

Routing in engine compartment

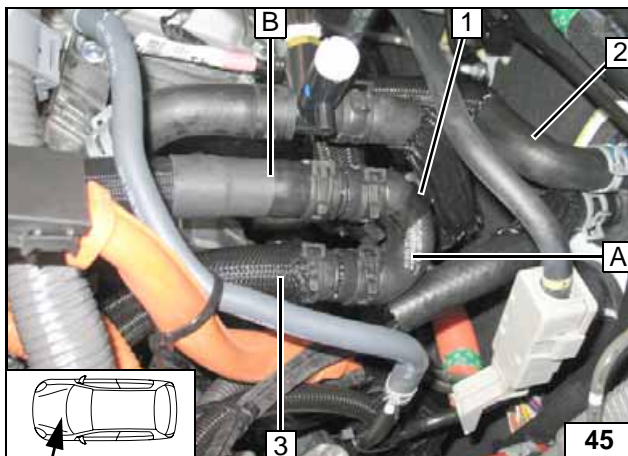

Mount spacer bracket 1 between hose A and the hose of heat exchanger outlet 2.

- 3 Hose of engine outlet



Connecting engine outlet

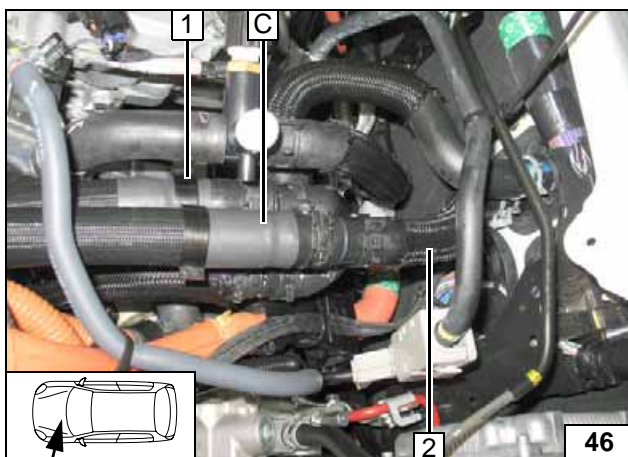

Ensure sufficient distance to neighboring components.

- 1 Spacer bracket
- 2 Hose on heat exchanger inlet



Connecting heat exchanger inlet

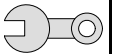

Final Work

WARNING!

Reassemble the disassembled components in reverse order.
 Check all hoses, clamps and all electrical connections for firm seating.
 Secure all loose cables using cable ties.
 Only use manufacturer-approved coolant.
 Spray the heater unit components with anti-corrosion wax (Tectyl 100K, Order No. 111329).

- Connect the battery
- Fill and bleed the coolant circuit according to the vehicle manufacturer's specifications.
- Set the digital timer.
- Make settings on A/C control panel according to the "Operating Instructions for End Customer".
- Check the proper operation of the additional heater, see the operating instructions/installation instructions.
- Mount information label "Switch off additional heater before refueling" in area of filler neck.

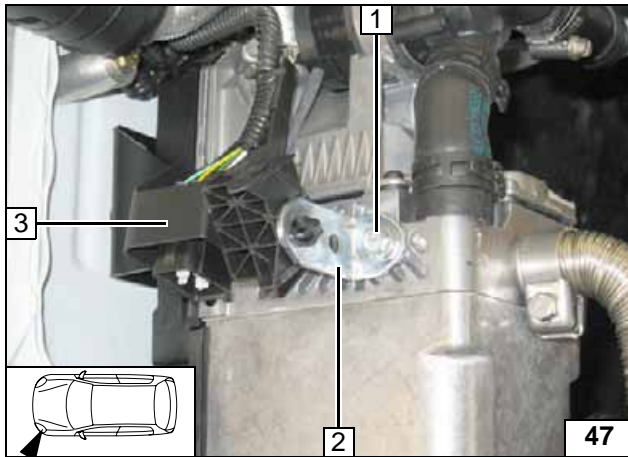

Insert the connectors of front fog light / blinker **3** into the oblong hole of angle bracket **2**.

1 E-jot screw

Installing connector



Webasto AG
 PO Box 80
 D-82131 Stockdorf / Germany
 National Hotline: 01805 93 22 78
 (14 cents from German landline network)
 Hotfax: 0395 5592 353
 Hotmail: hotline@webasto.de
<http://www.webasto.de>

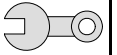

Template for fuel standpipe

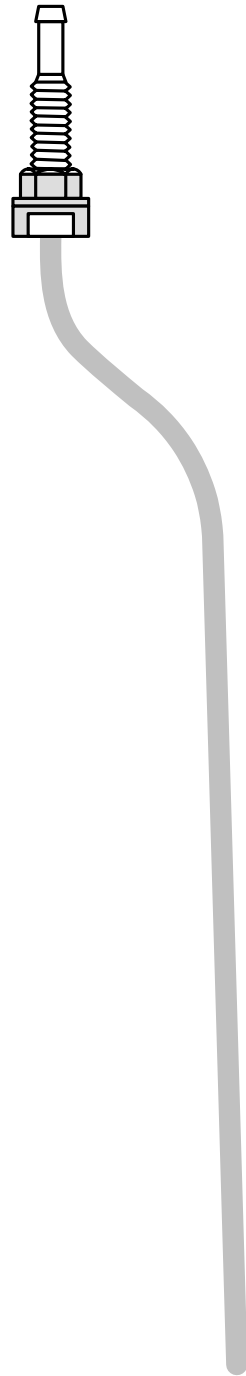

100 mm



Scale 1:1

Compare the size of the printed version with dimension lines.
Permitted tolerance a maximum of 2%.

Set the printer settings to "no margin" or "minimize margins" and 100% of the normal size.

100 mm

0

Operating Instructions for End Customer



Please remove page and add to the vehicle operating instructions.

Note:

We recommend matching the heating time to the driving time.

Heating time = driving time

Example:

For a driving time of approx. 20 min. (in one direction), we recommend not exceeding a switch-on time of 20 min.

For vehicles with a passenger compartment monitoring unit, deactivate it in addition to vehicle settings for the heating cycle.



Please refer to the operating manual of the vehicle for instructions regarding deactivation.

Note:

For information regarding load status indicator (Toyota No.: DENG5-56380-37) and optional charger XS3600 (Toyota No. DENG5-XS360-37), please refer to the separate Toyota instructions.



Before parking the vehicle, make the following settings:



- 1 Set temperature to "max."
- 2 Air outlet to windshield

**Automatic
air-condi-
tioning**