

# Water Heater



**Thermo Top E Parking Heater**

e1  
00 0003

**Thermo Top C Parking Heater**

e1  
00 0002

## Installation documentation

### Kia cee`d

Petrol

from model year 2010

Left-hand drive vehicle

Manual transmission



#### **WARNING!**

Hazard warning:

Incorrect installation or repair of Webasto heating systems may cause a fire or result in the emission of carbon monoxide, which can be fatal. Serious or fatal injuries can be caused as a result.



Specialist company training, technical documentation, specialised tools and equipment are required to install and repair Webasto heating and cooling systems. Only original Webasto parts must be used. For this, also see the catalog of air and water heater accessories from Webasto.

**NEVER attempt to install or repair Webasto heating or cooling systems if you have not successfully completed the company training and thereby acquired the required technical skills, or if you do not have access to the required technical documentation, tools and equipment needed to carry out correct installation and repairs.**

ALWAYS follow all Webasto installation and repair instructions and observe all warnings.

**The initial startup is to be executed with the Webasto Thermo Test Diagnosis.**

Webasto does not accept any liability for defects and damage that are attributable to installation by untrained staff.

## Table of Contents

|  |    |   |    |
|--|----|---|----|
| Validity                                   | 2  | Preparing heater                            | 12 |
| Heater/Installation Kit                    | 3  | Preparing installation location             | 13 |
| Foreword                                   | 3  | Installing heater                           | 14 |
| General Instructions                       | 3  | Combustion air                              | 16 |
| Special Tools                              | 3  | Coolant circuit                             | 17 |
| Explanatory notes on document              | 4  | Fuel  | 23 |
| Preliminary work                           | 5  | Exhaust gas                                 | 27 |
| Heater installation location               | 5  | Final Work                                  | 29 |
| Electrical system                          | 6  | Template for fuel standpipe                 | 30 |
| Fan controller for manual air conditioning | 7  | Operating Instructions for the End Customer | 31 |
| Automatic air-conditioning fan controller  | 9  |   |    |
| Remote option (Telestart)                  | 11 |   |    |

## Validity

| Manufacturer | Model | Type | EG-BE No. / ABE        |
|--------------|-------|------|------------------------|
| Kia          | cee`d | ED   | e4 * 2001/116 * 0121 * |

| Engine type | Engine model | Output in kW | Displacement in cm <sup>3</sup> |
|-------------|--------------|--------------|---------------------------------|
| G4FA        | Petrol       | 66           | 1396                            |
| G4FA        | Petrol       | 80           | 1396                            |
| G4FC        | Petrol       | 92           | 1591                            |

Vehicle and engine types, equipment variants and national specifications not listed in this installation documentation have not been tested. However, installation according to this installation documentation may be possible.

The installation location of the digital timer is to be coordinated with the end customer before installation.

**Heater/Installation Kit**

| Quantity | Designation                                | Order No.:     |
|----------|--|----------------|
| 1        | Retail accessories <i>Thermo Top E / C</i> | See Price list |
| 1        | Heater control                             | See Price list |
| 1        | Installation kit for Kia cee`d 2010 petrol | 1312333F       |

**Heater recommended for the respective vehicle class:**

| Vehicle                  | Heater       |
|--------------------------|--------------|
| Compact car              | Thermo Top E |
| Mid-size car, estate car | Thermo Top C |

The selection of the heater is based on the passenger compartment size of the vehicle and the level of comfort required by the customer.

**Foreword**

This installation documentation applies to Kia cee`d Petrol vehicles - for validity, see page 2 - from model year 2010 and later, assuming technical modifications to the vehicle do not affect installation, any liability claims excluded. Depending on the vehicle version and equipment, modifications may be necessary during installation with respect to this installation documentation.

However, the stipulations in the "installation documentation", the "operating instructions" and "installation instructions" for the *Thermo Top C/E* must always be observed.

The corresponding rules of technology and any information from the vehicle manufacturer should be observed during the installation work.

**General Instructions**

Installation should be carried out according to the general, standard rules of technology. Unless specified otherwise, fasten hoses, lines and wiring harnesses to original vehicle lines and wiring harnesses using cable ties.

Sharp edges should be fitted with rub protection (split-open fuel hose).

Spray unfinished body areas, e.g. drilled holes, with anti-corrosion wax (Tectyl 100K, Order No. 111329).

**Special Tools**

- Torque wrench for 2.0 - 10 Nm
- Hose clamping pliers
- Metric thread-setter kit

**Explanatory notes on document**

To provide you with a quick overview of the individual working steps, you will find an identification mark on the outside top right corner of the page in question.

**Mechanical system**

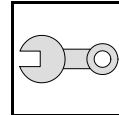

**Electrical system**

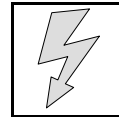

**Coolant circuit**

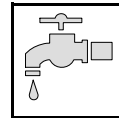

**Fuel**

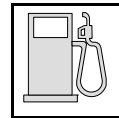

**Exhaust gas**

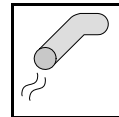

**Combustion air**

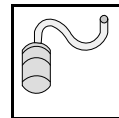

Special features are highlighted using the following symbols:



Specific risk of injury or fatal accidents.



Specific risk of damage to components.



Specific risk of fire or explosion.



Reference to general installation instructions of Webasto components or to the manufacturer's vehicle-specific documents.



Reference to a special technical feature.



The arrow in the vehicle icon indicates the position on the vehicle and the viewing angle.

**All dimensions are in mm!**  
**Tightening torque of hose clamps = 2.0 + 0.5 Nm!**  
**Tightening torque of Ejet screws, Ejet studs = 10 Nm!**

## Preliminary work

### WARNING!

- Open the fuel tank cap and vent the fuel tank.
- Close the fuel tank cap again.
- Disconnect the battery "earth" or "ground" connection.
- Depressurise the cooling system.
- Copy the factory number from the original type label to the duplicate type label.
- Remove years that do not apply from the duplicate label.
- Attach the duplicate label (type label) in the appropriate place.
- Remove the door sill trim on the front passenger's side.
- Remove the A-pillar trim in the front passenger's side footwell.
- Remove the lower instrument panel trim on the driver's side.
- Fold up the rear bench seat.
- Open the tank-fitting service lid.
- Remove the air filter together with the intake hoses.
- Detach the trim of the cable pass through on the firewall.
- Detach the wheel well trim on the right and left.
- Remove the bumper.
- Remove the rear left tank trim.

Remove page 31 "Operating Instructions for the End Customer" and add to the vehicle operating instructions.



### Heater installation location

1 Heater

Installation location



**Electrical system**

**Wiring harness pass through**

- 1 Cover
- 2 Protective rubber plug



**Digital timer**

- 1 Digital timer

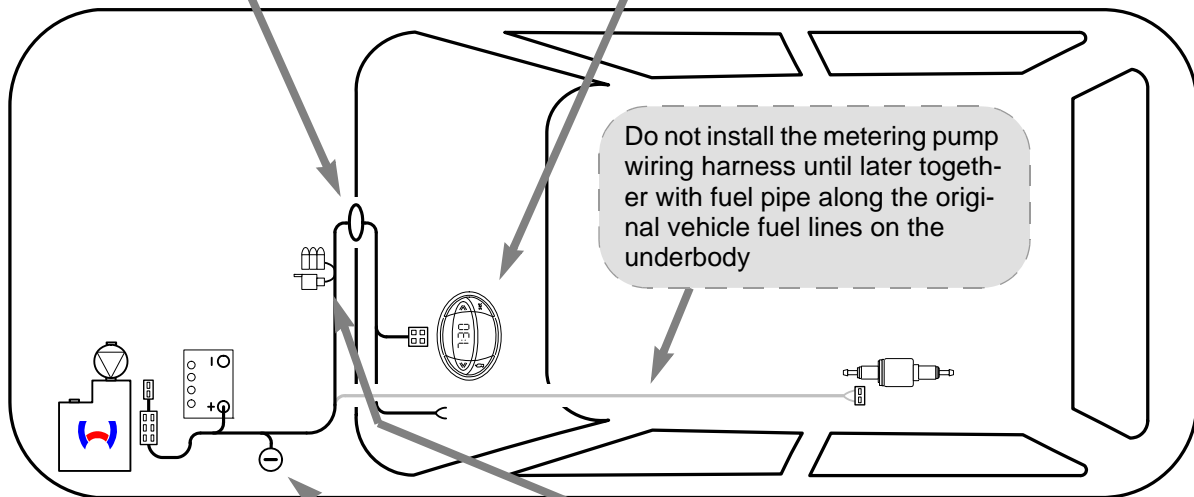
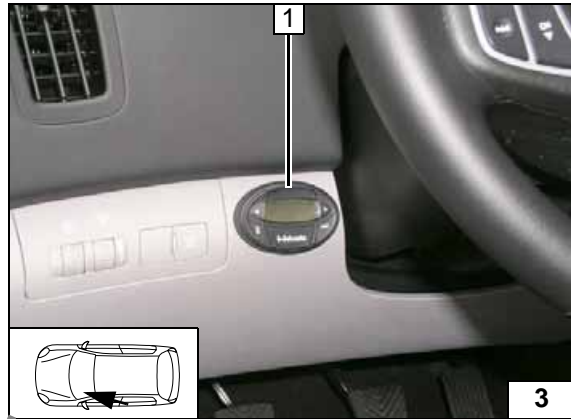

**Wiring harness routing diagram**

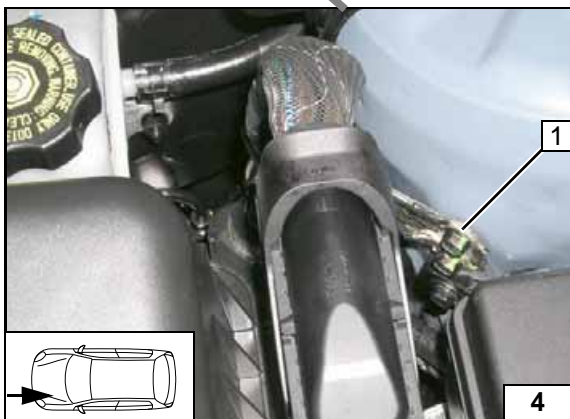

**Earth connection**

- 1 Earth point on strut tower

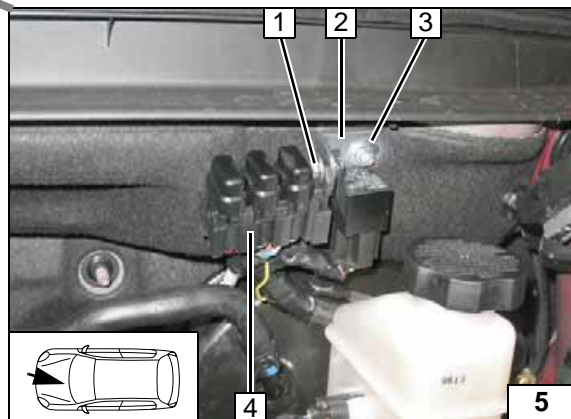

**Fuse holder, K3 relay**

Remove plastic nut at position 3.

- 1 M5x16 bolt, washer, retaining plate for fuse holder, K3 relay, flanged nut
- 2 Angle bracket
- 3 Flanged nut, original vehicle stud bolt
- 4 Replace F3 25A fuse with 10A fuse, F1-3 fuses mounted.



Fan controller for manual air conditioning

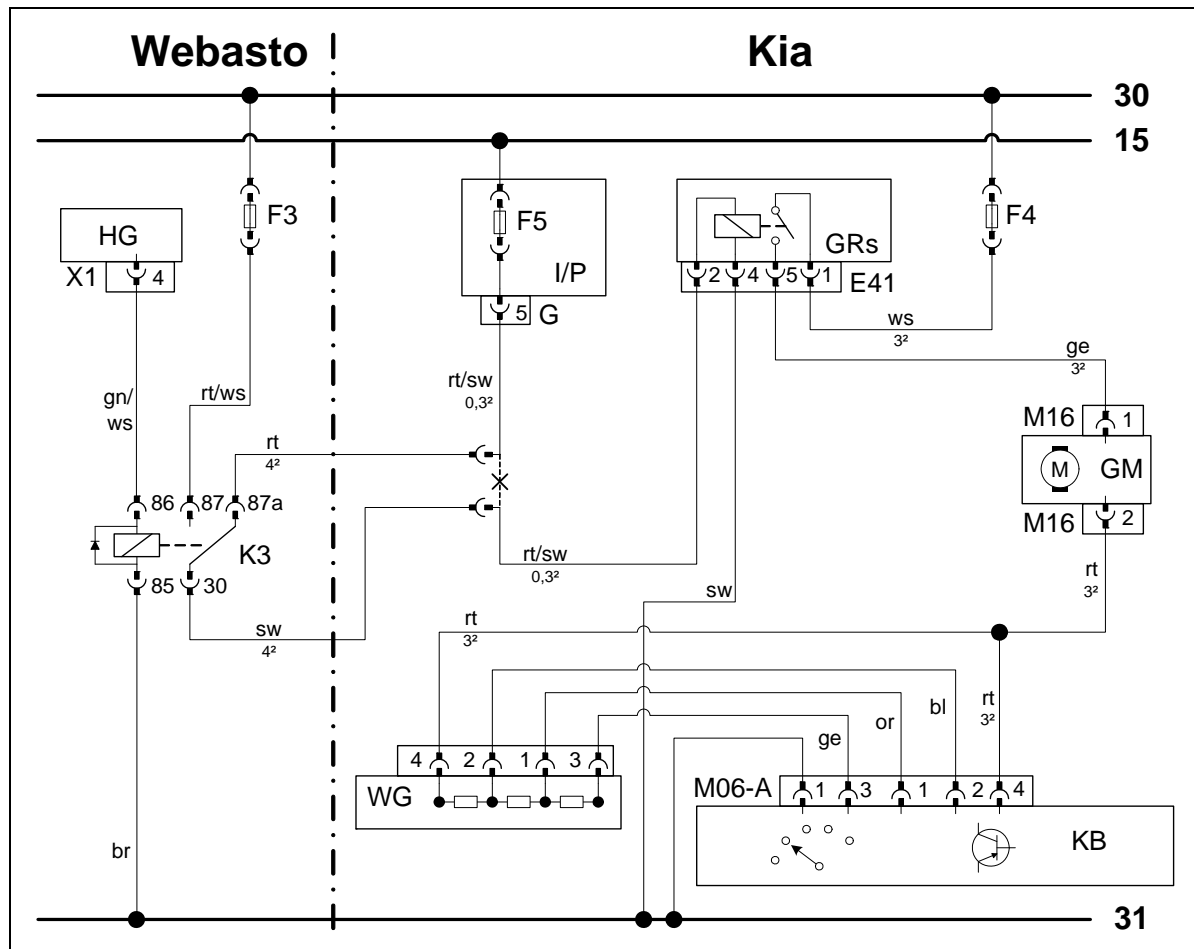

Wiring diagram

| Webasto components |                              | Vehicle components |                                     | Colours and symbols      |               |
|--------------------|------------------------------|--------------------|-------------------------------------|--------------------------|---------------|
| HG                 | TT-C/E Heater                | GM                 | Fan motor                           | rt                       | red           |
| X1                 | 6-pin heater connector       | M16                | Connector GM                        | ws                       | white         |
| F3                 | Replace 25 A with 10 A fuse. | KB                 | A/C control panel / Fan switch      | sw                       | black         |
| K3                 | Fan relay                    | M06-A              | 6-pin connector KB                  | br                       | brown         |
|                    |                              | GRs                | Fan relay                           | gn                       | green         |
|                    |                              | E41                | 5-pin connector GRs                 | bl                       | blue          |
|                    |                              | F4                 | Fuse blower 40A                     | ge                       | yellow        |
|                    |                              | F5                 | Fuse A/CON 10 A                     | or                       | orange        |
|                    |                              | I/P                | Branching box Passenger compartment |                          |               |
|                    |                              | G                  | 21- pin I/P connector               |                          |               |
|                    |                              | GRs                | Fan relay                           | X                        | Cutting point |
|                    |                              | E41                | 5-pin connector GRs                 | Wiring colours may vary. |               |

Legend

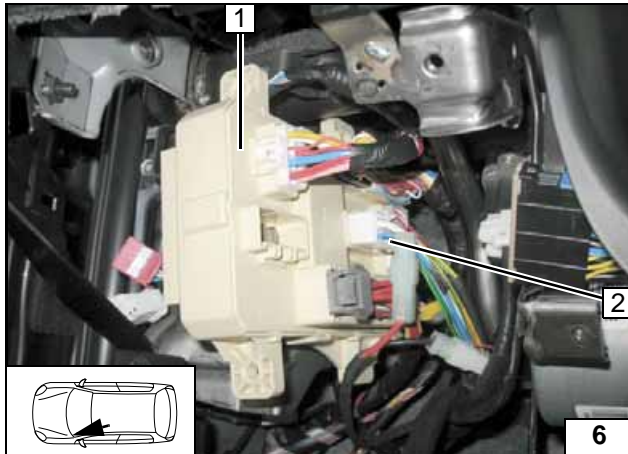
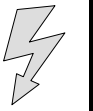

Connection to branching box of passenger compartment. Central electrical box 1 released for better display. Pull out I/P-G connector 2



Connect-  
ing fan re-  
lay

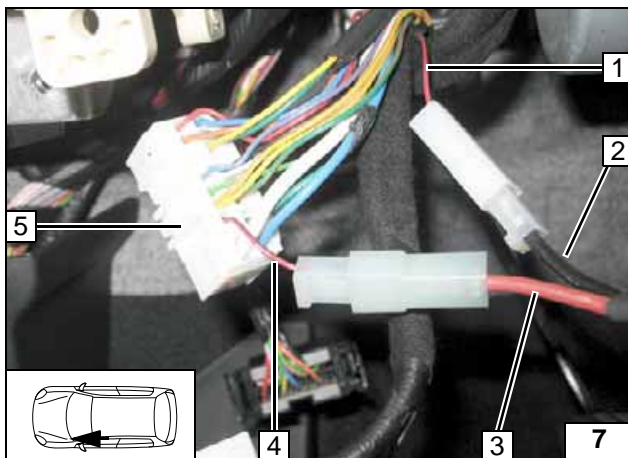

Produce connections as shown in wiring diagram.

- 1 Red/black (rt/sw) wire from fan relay
- 2 Black (sw) wire from K3/30
- 3 Red (rt) wire from K3/87a
- 4 Red/black (rt/sw) wire connector I/P-G, Pin 5
- 5 I/P-G connector



Connect-  
ing fan re-  
lay

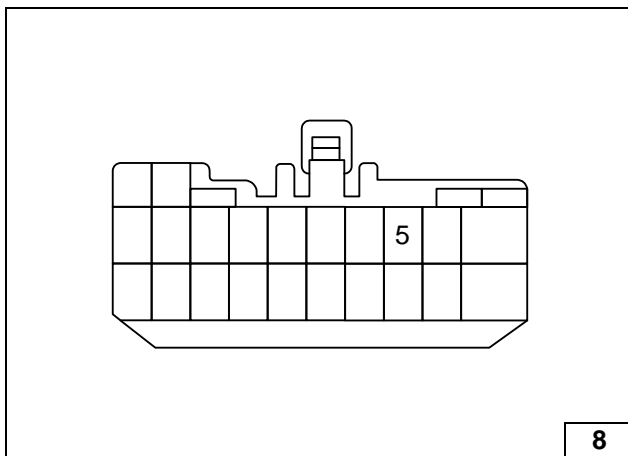

Pull out I/P-D connector on contact side



Connector  
I/P-G





Automatic air-conditioning fan controller

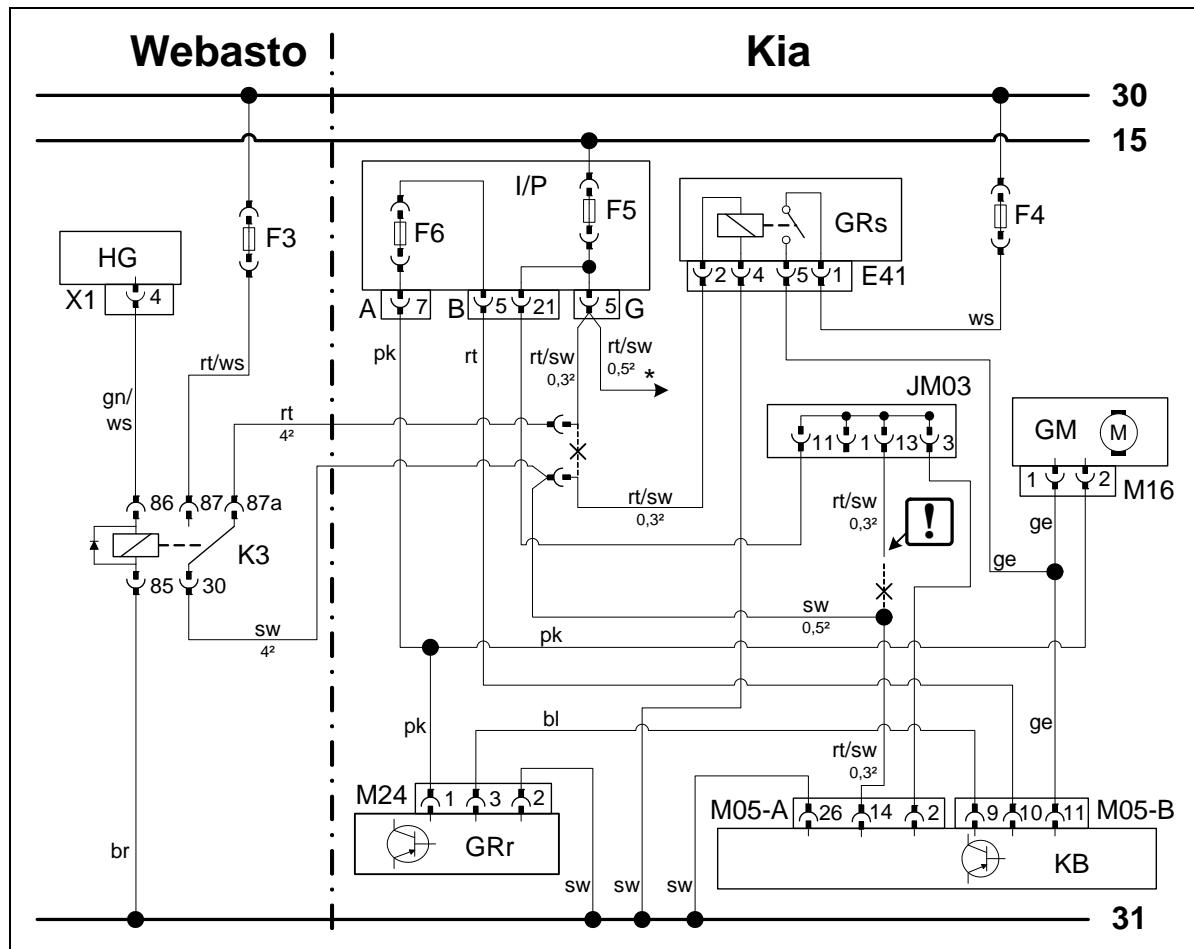

Wiring diagram

| Webasto components |                               | Vehicle components |                        | Colours and symbols |                                |
|--------------------|-------------------------------|--------------------|------------------------|---------------------|--------------------------------|
| HG                 | TT-C/E Heater                 | GM                 | Fan motor              | rt                  | red                            |
| X1                 | 6-pin heater connector        | M16                | Connector GM           | ws                  | white                          |
| F3                 | 25 A replaced with 10 A fuse. | KB                 | A/C control panel      | sw                  | black                          |
| K3                 | Fan relay                     | M05-A              | 26-pin connector KB    | or                  | orange                         |
|                    |                               | M05-B              | 22-pin connector KB    | gn                  | green                          |
|                    |                               | F4                 | Fuse, 40A              | bl                  | blue                           |
|                    |                               | F5                 | Fuse, 10A              | ge                  | yellow                         |
|                    |                               | F6                 | Fuse, 10A              | pk                  | pink                           |
|                    |                               | GRs                | Fan relay              |                     |                                |
|                    |                               | E41                | 5-pin connector GRs    | *                   | Control Wire PTC Heater Relay  |
|                    |                               | JM03               | Connector              | !                   | Insulate wire end and tie back |
|                    |                               | GRr                | Fan controller         | X                   | Cutting point                  |
|                    |                               | M24                | 3-pin connector, GRr   |                     |                                |
|                    |                               | I/P                | Central electrical box |                     |                                |
|                    |                               | G                  | 22-pin I/P connector   |                     | Wiring colours may vary.       |

Legend

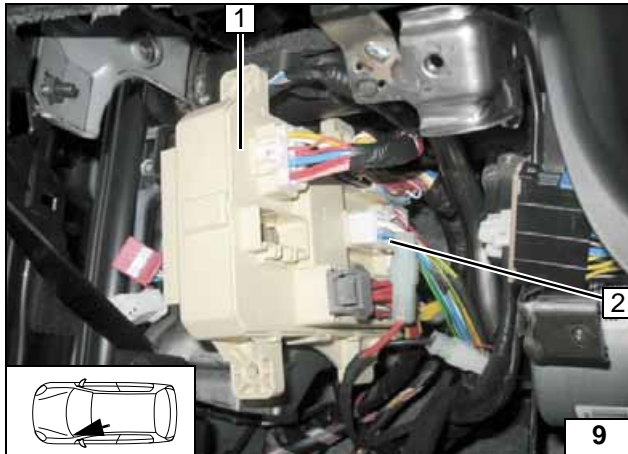
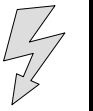

Central electrical box **1** released for better display. Pull out I/P-G connector **2**.



Connect-  
ing I/P cen-  
tral  
electrical  
box

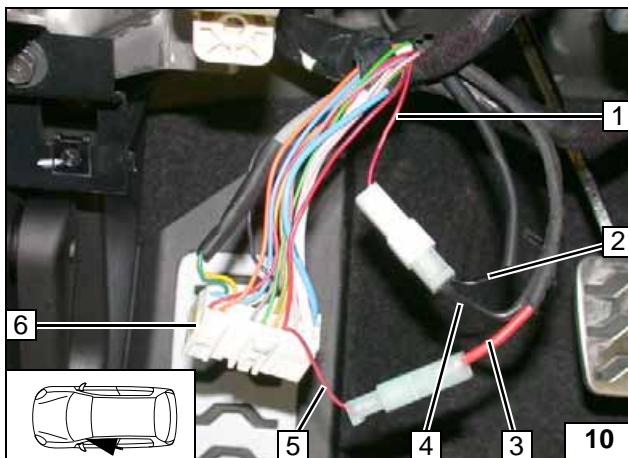

Connection with I/P-G connector **6** from central electrical box. Pull out I/P-G connector. Measure out red/black wire **5** from fan relay in the engine compartment, if necessary. Produce connections as shown in wiring diagram.



Connect-  
ing I/P cen-  
tral  
electrical  
box

- 1** Red/black (rt/sw) wire from fan relay
- 2** Black (sw) additional 0.5<sup>2</sup> wire from A/C control panel
- 3** Red (rt) wire from K3/87a
- 4** Black (sw) wire from K3/30
- 5** Red/black (rt/sw) wire connector I/P-G, Pin 5

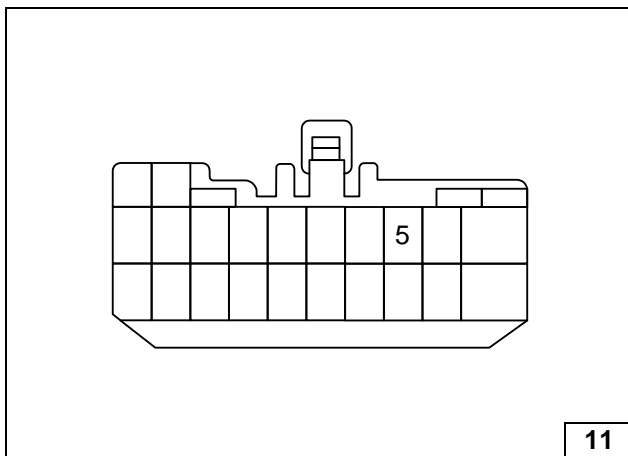

Pull out I/P-D connector on contact side



Connector  
I/P-G

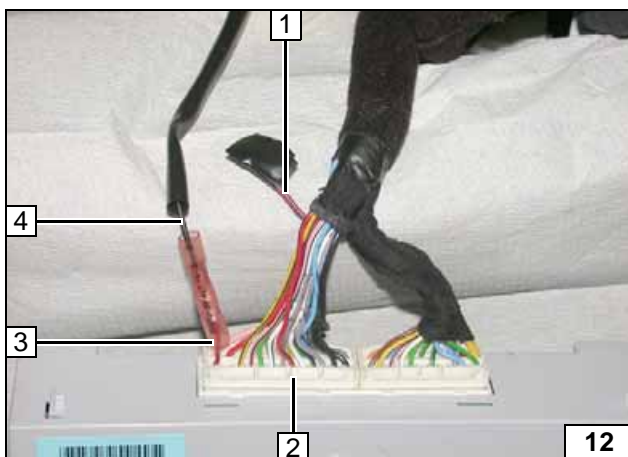

Connection on M05-A connector **2** A/C control panel. Insulate and tie back red/black (rt/sw) wire **1** from JM03 PIN 13 connector. Produce connections as shown in wiring diagram.



Connect-  
ing A/C  
control  
panel

- 3** Red/black (rt/sw) wire from M05-A connector PIN 14
- 4** Black (sw) additional 0.5<sup>2</sup> wire from K3/30

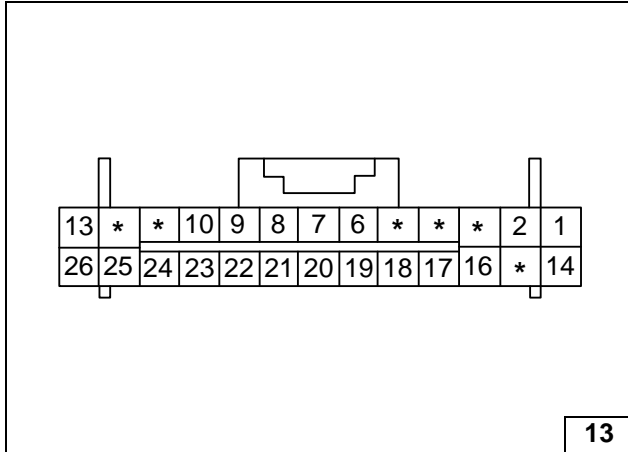

M05-A connector on contact side



Connector M05-A

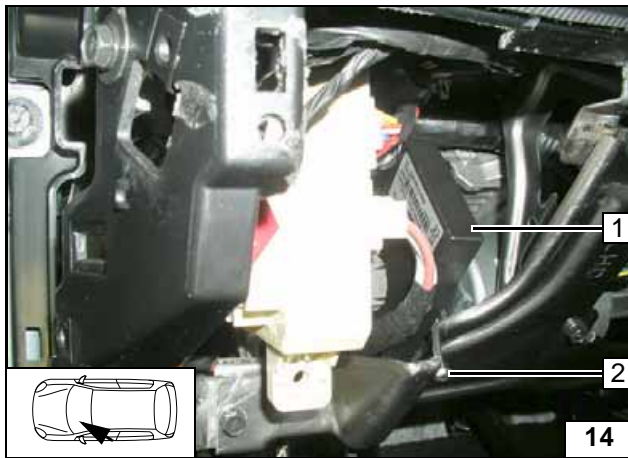

**Remote option (Telestart)**

- 1 Receiver, bracket angled down
- 2 5.5 mm dia. hole, M5x16 bolt, flanged nut



Mounting receiver

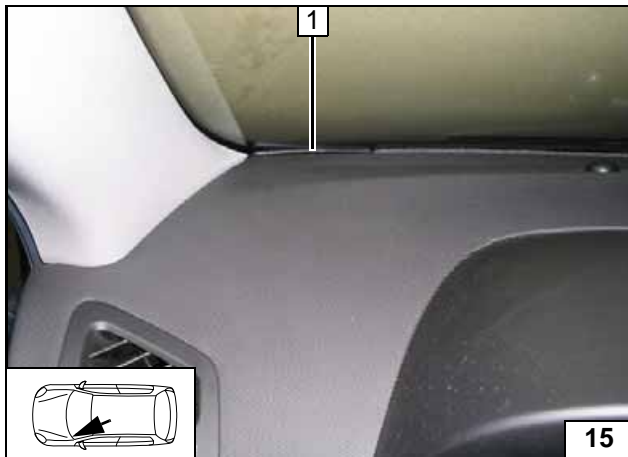

- 1 Antenna

Mounting antenna

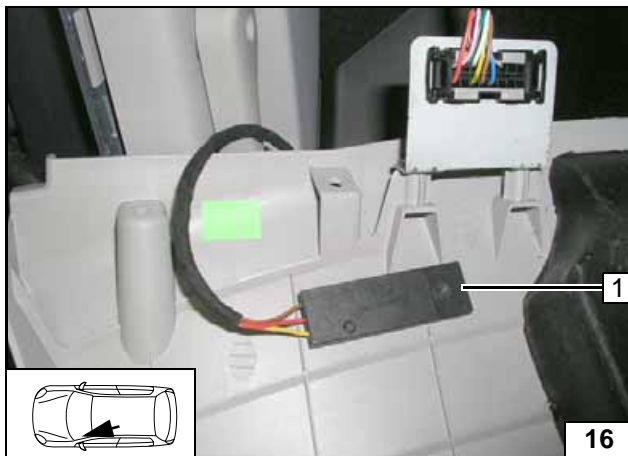

**Temperature sensor only for T100 HTM**

- 1 Temperature sensor, fasten with suitable means

Mounting temperature sensor

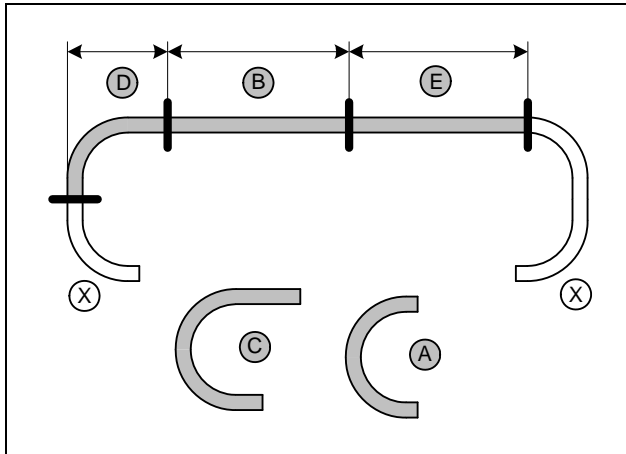
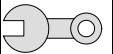

### Preparing heater

Discard section **X**  
**A** = 180°, 18x18mm dia. moulded hose  
**C** = 180°, 20x20mm dia. moulded hose

**B** = 1020  
**D** = 130  
**E** = 1050



**Cutting hoses to length**

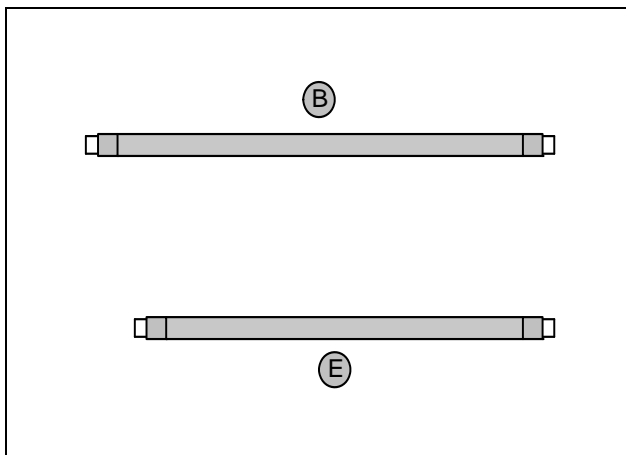

Push braided protection hose onto hose **B** and **E** and cut to length.  
 Cut heat shrink plastic tubing to length.

**1** 25mm heat shrink plastic tubing [4x]



**Preparing hoses**

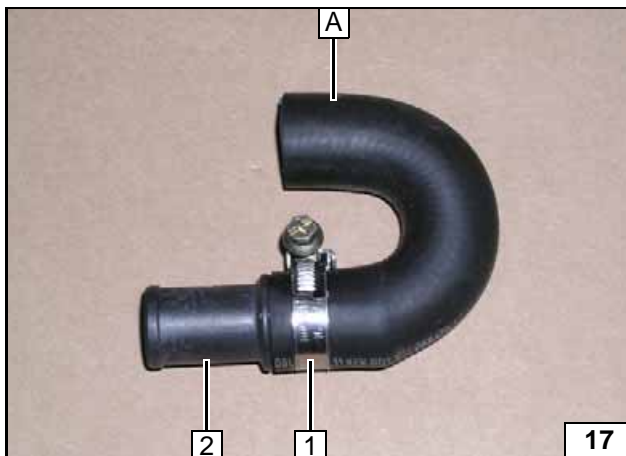

**1** 27 mm dia. clamp  
**2** 18x20 mm dia. connecting pipe

**Preparing hose A**

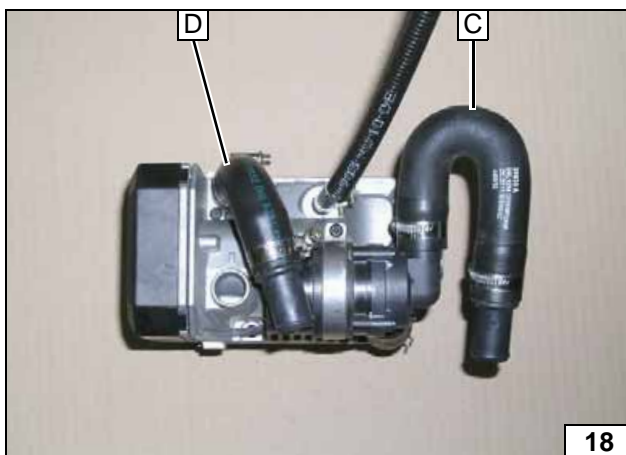

**D** Hose section, 20x20 mm dia. connecting pipe, 27 mm dia. clamp [2x]  
**C** 180°, 20x20mm dia. moulded hose, 20x20 mm dia. connecting pipe, 27 mm dia. clamp [2x]

**Premounting coolant hoses on heater**

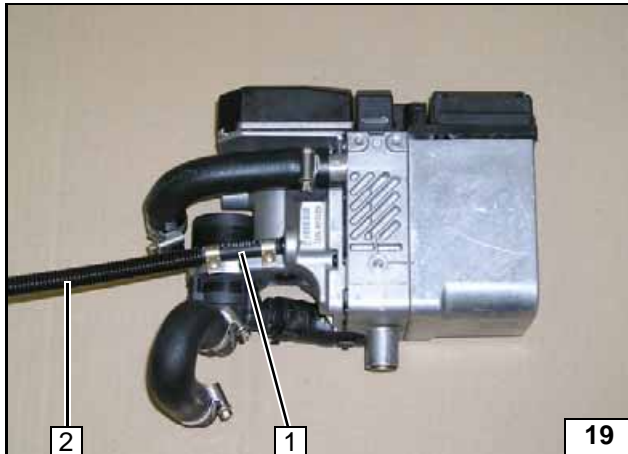
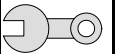

- 1 Hose section, 10 mm dia. clamp [2x]
- 2 Fuel line in corrugated hose

Premounting fuel hose on heater

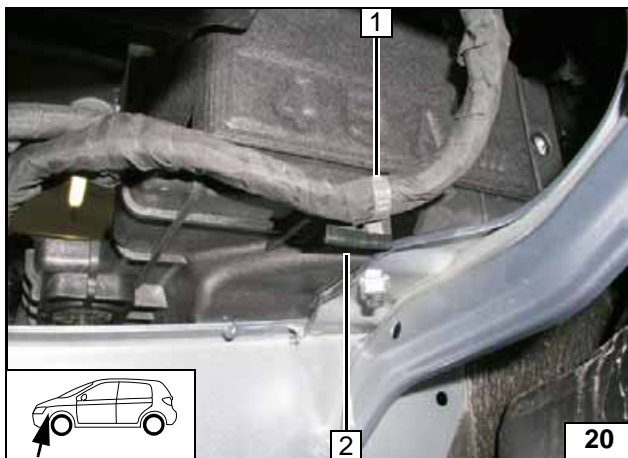

**Preparing installation location**

- 1 Original vehicle retaining clip released
- 2 Insert 30 mm edge protection

Moving wiring harness

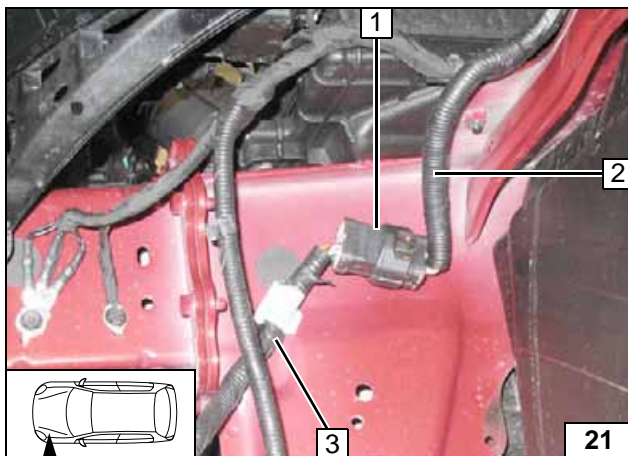

Detach connector 1 and retaining clip 3 . Tie back original vehicle wiring harness 2 with cable tie.



Moving wiring harness

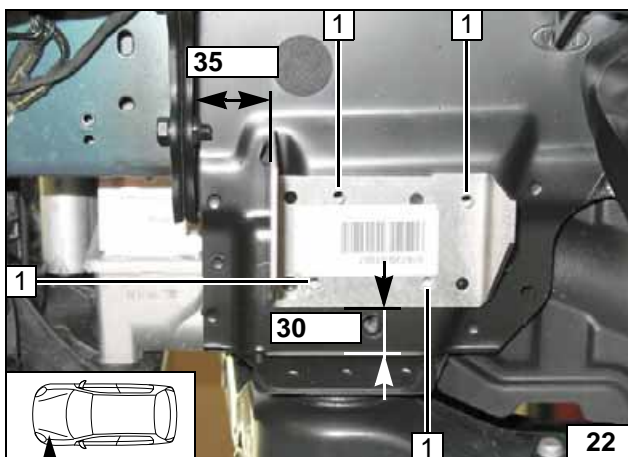

Align bracket 2, copy hole pattern 1 [4x]



Copying hole pattern

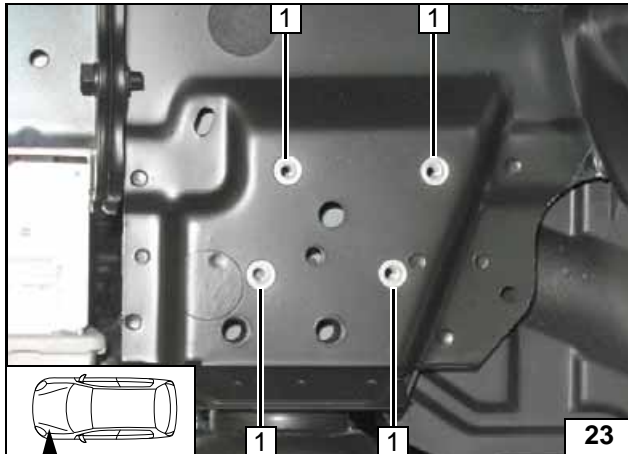
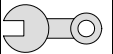

1 9.1 mm dia. hole; rivet nuts [4x each]

Installing rivet nuts

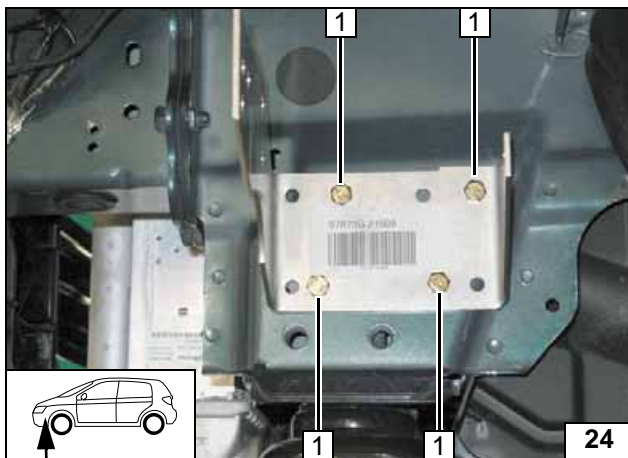

1 M6x25 bolt, spring lockwasher [4x each]

Installing bracket

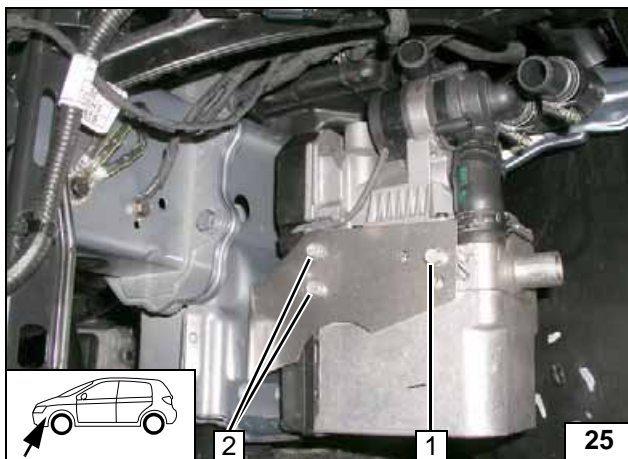

**Installing heater**

Insert two washers between heater and bracket at position 1.

- 1 E-jot screw, washer [2x]
- 2 E-jot screw [2x]



Mounting heater

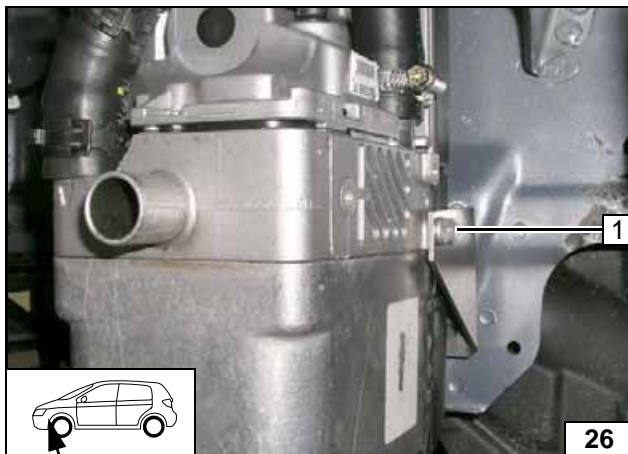

1 E-jot screw

Mounting heater

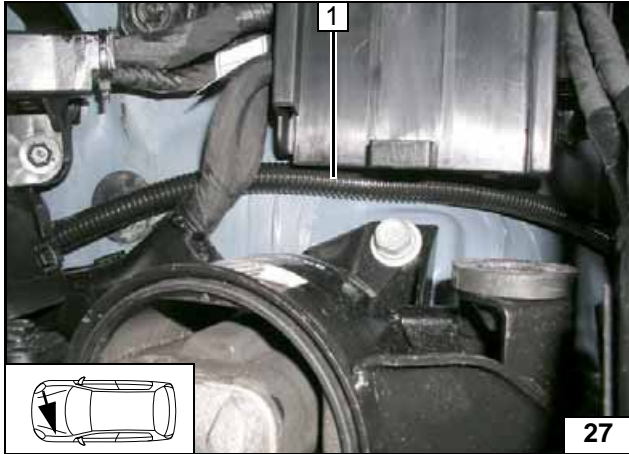
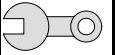

Route fuel line and wiring harness of metering pump in corrugated tube 1 to firewall and along original vehicle fuel lines to underbody.



**Routing fuel line and wiring harness**

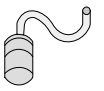

**Combustion air**

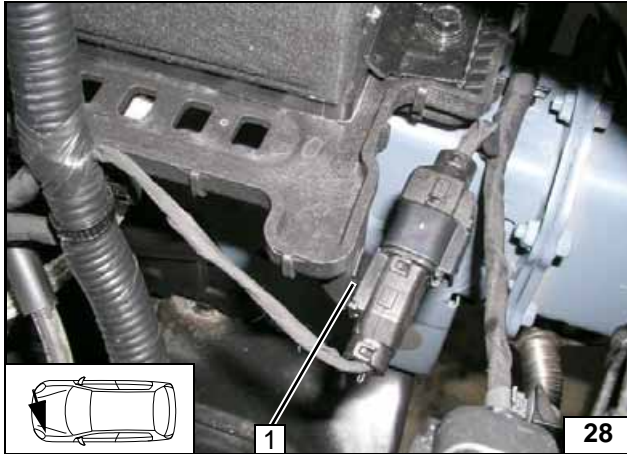

- 1 Retaining clip

Releasing retaining clip of connector

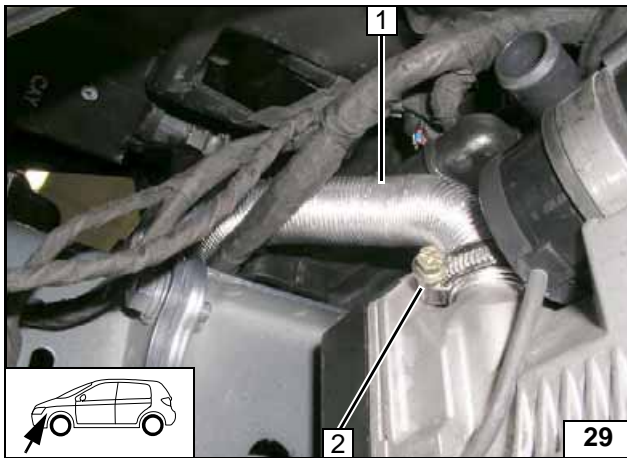

- 1 Combustion-air intake pipe
- 2 27 mm dia. hose clamp



Installing intake pipe

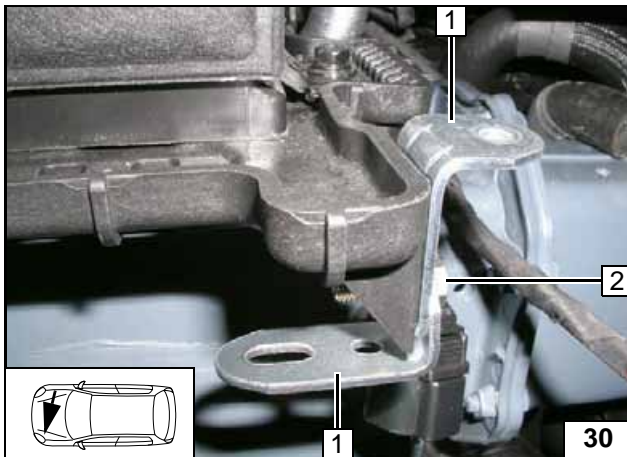

- 1 Angle bracket [2x]
- 2 M6x20 bolt, flanged nut

Installing angle bracket

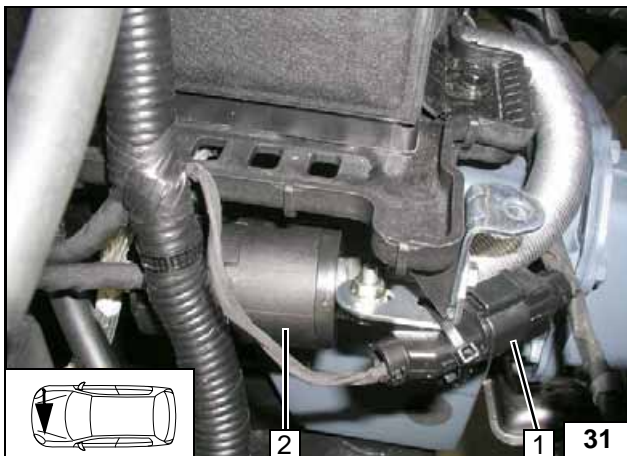

- 1 Original vehicle connector, cable tie on angle bracket
- 2 Combustion-air intake silencer, 25 mm dia. p-clamp, M6x20 bolt, flanged nut on angle bracket



Mounting silencer



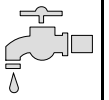

### Coolant circuit



**WARNING!**

Any coolant running off should be collected in a suitable container. Install hoses so that they are kink-free. Unless specified otherwise, always fasten using cable ties. Position clamps so that other hoses cannot be damaged. The heater must be filled with coolant when installing the hoses. The connection should be "inline" based on the following diagram:

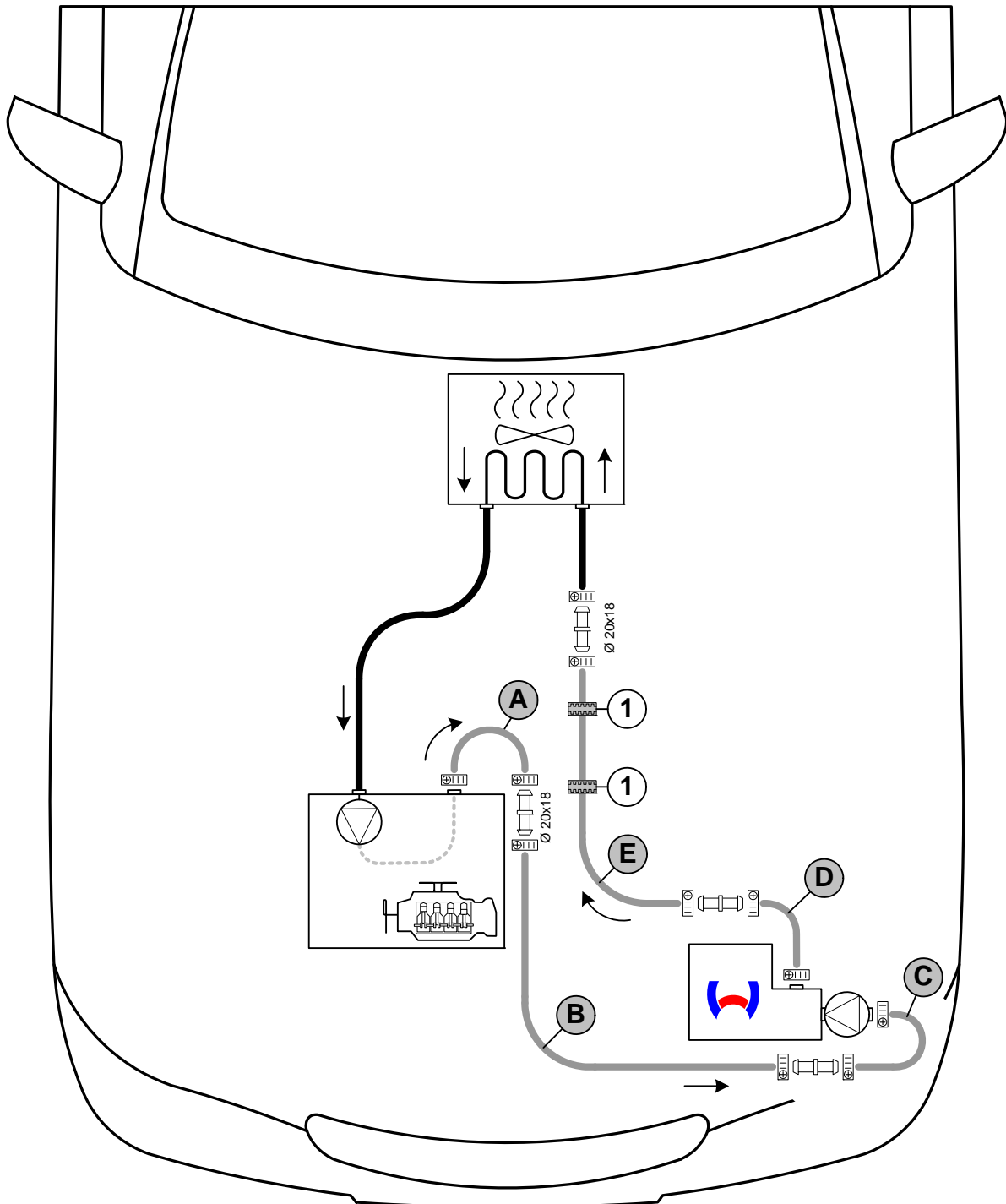

Hose installation diagram



All hose clamps  = 20-27 mm dia. All connecting pipes without a specific designation  = 20x20 mm.  
**1** = Black (sw) rubber isolator  [2x]!



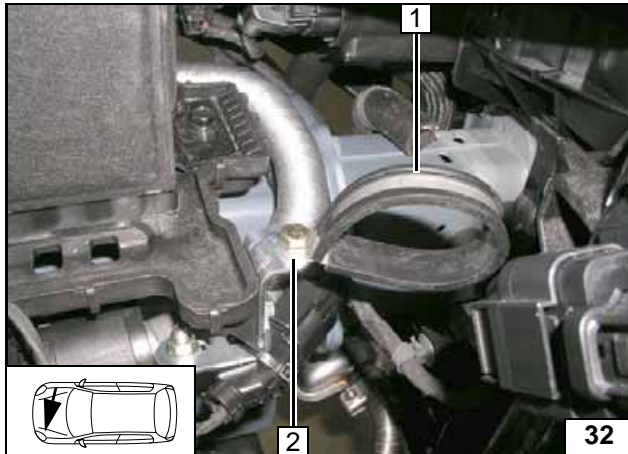

- 1 Rubber-coated pipe clamp, 48 mm dia.
- 2 M6x20 bolt, flanged nut

Installing p-clamp

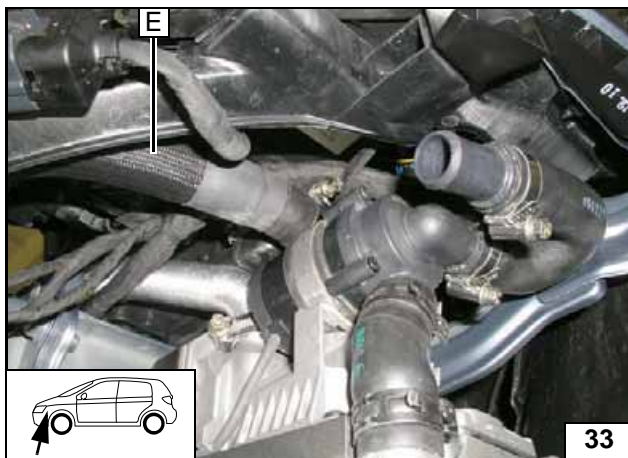

Connect-  
ing heater  
outlet

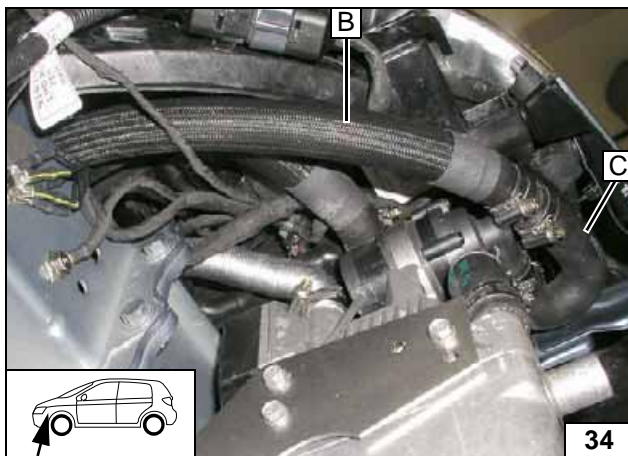

Connect-  
ing heater  
inlet

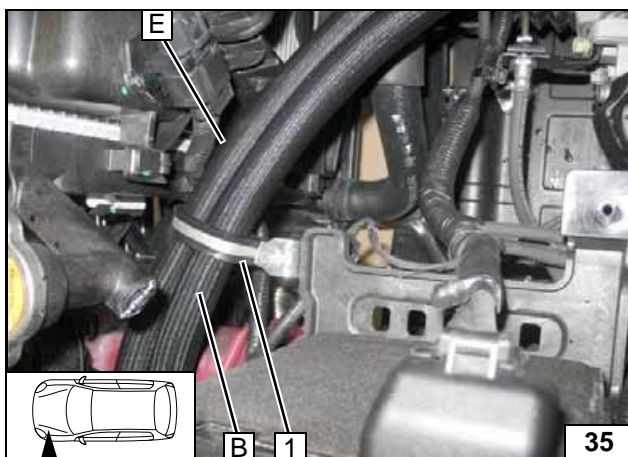

66 KW

Route hose **B** and **E** through rubber-coated p-clamp 1.



Routing in  
engine  
compart-  
ment

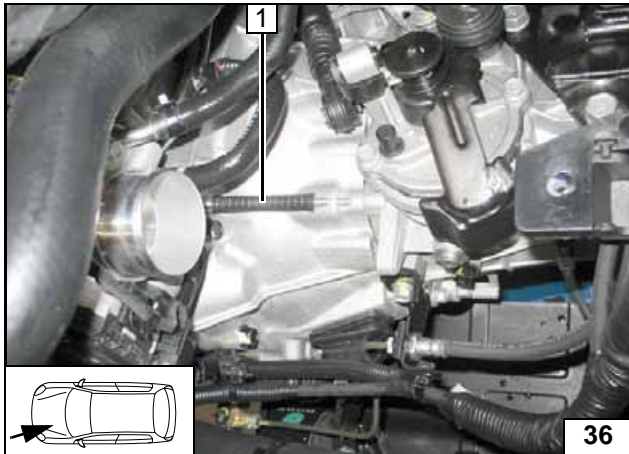
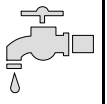

Mount 50mm edge protection 1 on transmission.



Inserting edge protection

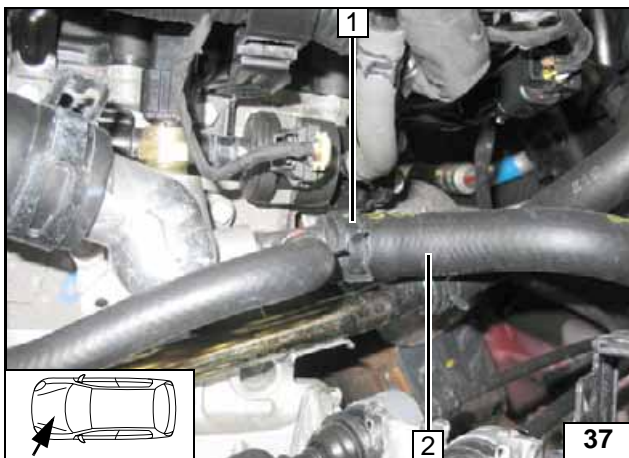

Pull original vehicle hose 2 off connection piece of engine outlet. Spring clip 1 will not be reused.



Cutting point

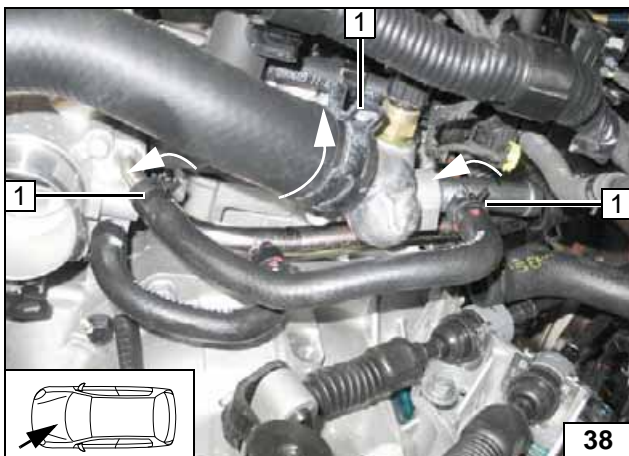

Twist original vehicle clamps 1 [3x].



Aligning clamps

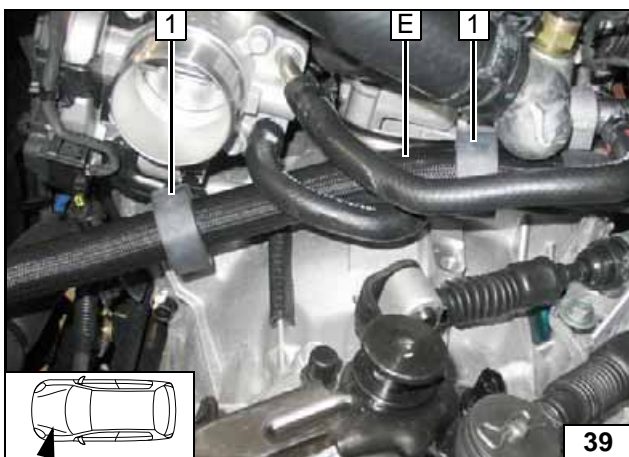

Slide rubber isolator 1 [2x] on to hose E and align as shown



Aligning rubber isolator

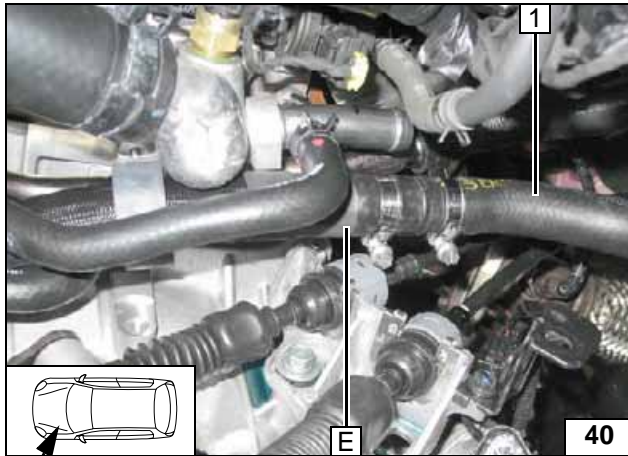

1 Hose on heat exchanger inlet

Connect-  
ing heat  
exchanger  
inlet

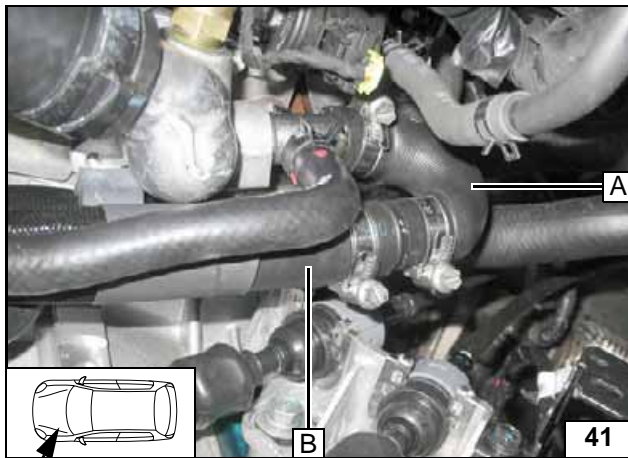

Connect-  
ing engine  
outlet

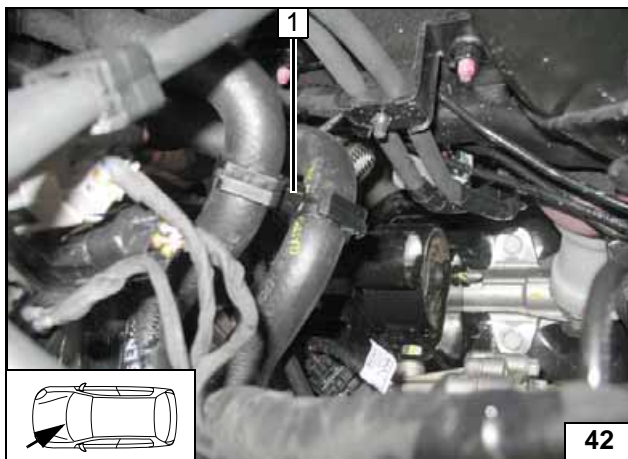

Align hoses.  
Ensure sufficient distance to adjacent compo-  
nents, correct if necessary.

1 Spacer bracket

Install-  
ing  
spacer  
bracket

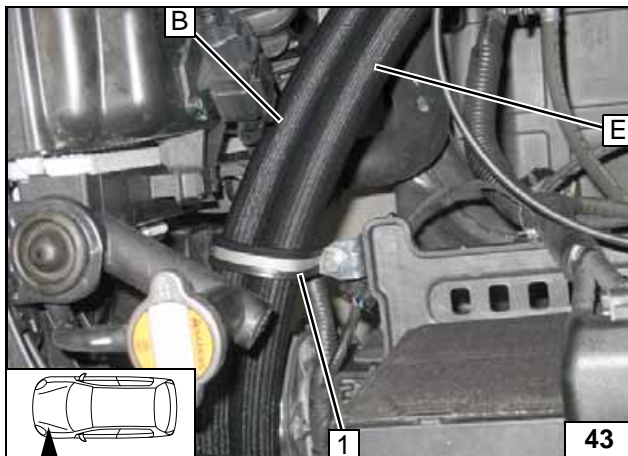

80 and 92 KW

Route hose **B** and **E** through rubber-coated  
p-clamp **1**.

Routing in  
engine  
compart-  
ment

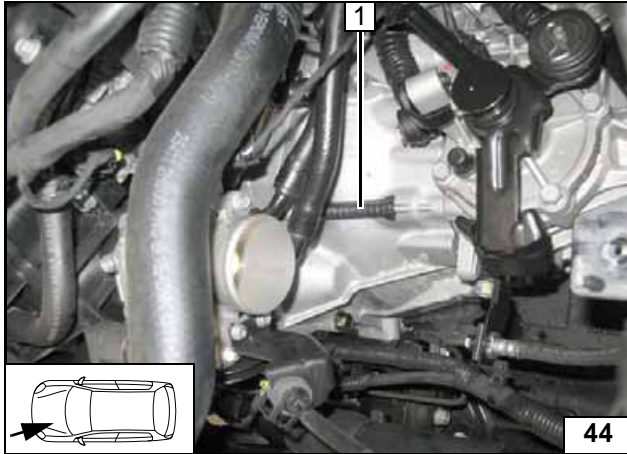
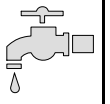

Mount 50mm edge protection 1 on transmission.



Inserting edge protection

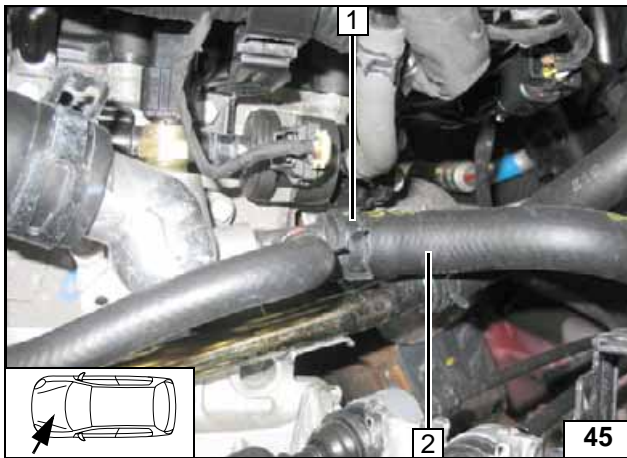

Pull original vehicle hose 2 off connection piece of engine outlet. Spring clip 1 will not be reused.



Cutting point

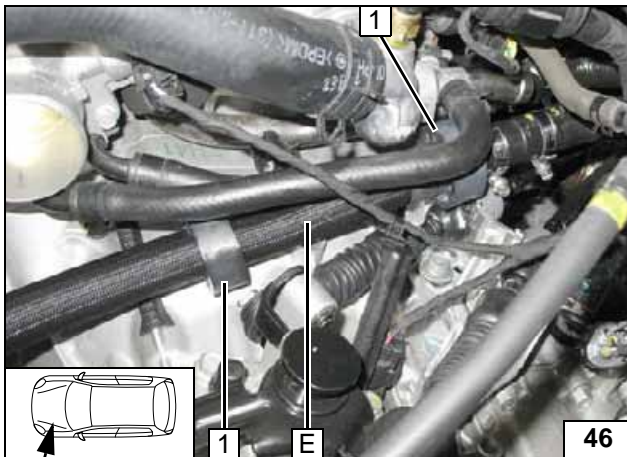

Slide rubber isolator 1 [2x] on to hose E and align as shown



Aligning rubber isolator

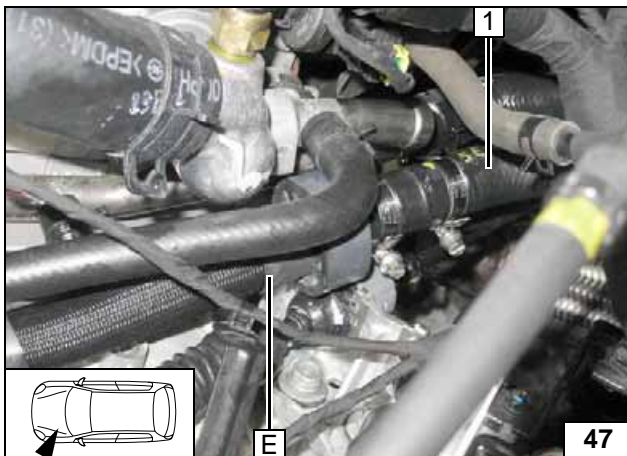

1 Hose on heat exchanger inlet

Connecting heat exchanger inlet

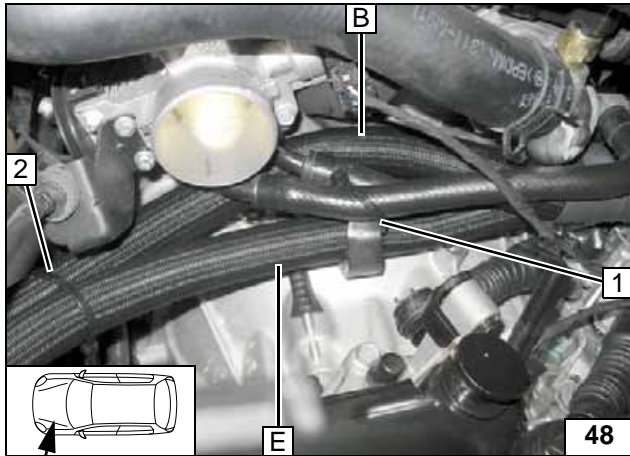

Fix rubber isolator with cable tie 1 on original vehicle wire.

2 Cable tie



Routing in engine compartment

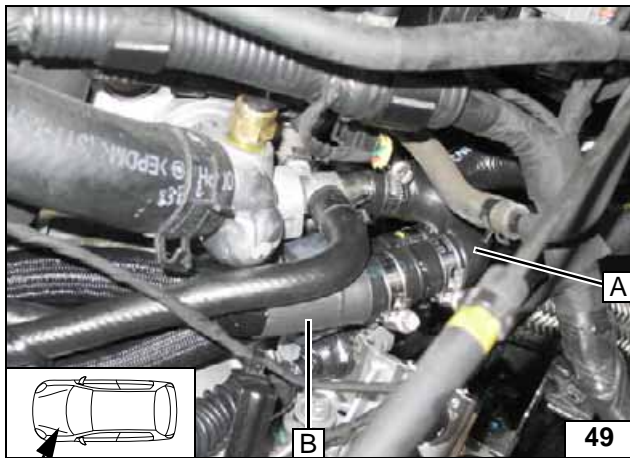

Connecting engine outlet

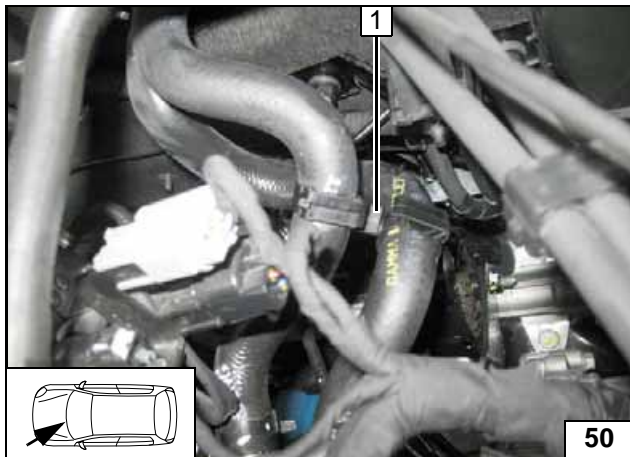

Align hoses. Ensure sufficient distance to adjacent components, correct if necessary.

1 Spacer bracket



Installing spacer bracket



**Fuel**

**CAUTION!**

Open the vehicle's fuel tank cap, ventilate the tank and then re-close the tank lock.

Catch any fuel running off in a suitable container.

Install fuel line and metering pump wiring harness so that they are protected against stone impact. Unless specified otherwise, always fasten using cable ties. Mount the fuel line and wiring harness with rub protection on sharp edges.

**WARNING!**

The fuel line and wiring harness are routed to the metering pump as shown in the wiring harness routing diagram.

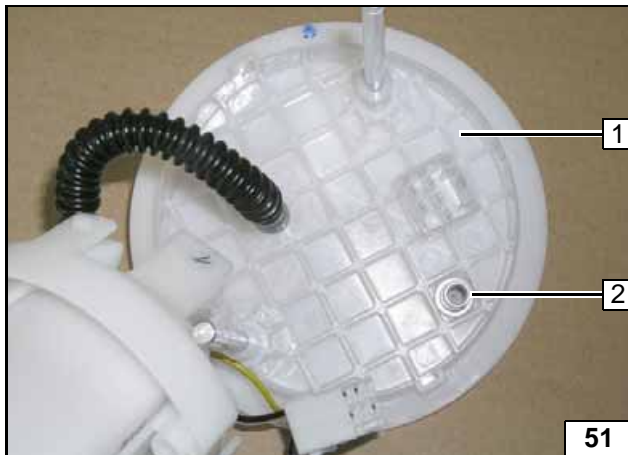

Remove and dismantle fuel-tank sending unit according to manufacturer's instructions. Mount rivet nut **2** for centring in centre of cover segment **1** and pre-drill 5 mm dia.

Copying hole pattern



**1** Drill out 6 mm dia. hole

Drilling hole in fuel-tank sending unit

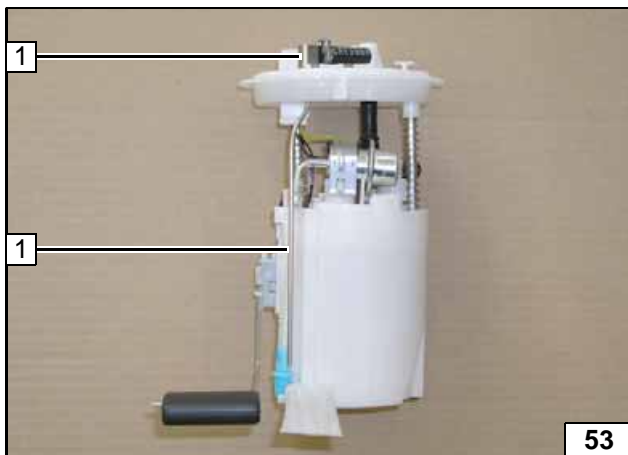

Mould fuel standpipe **1** according to template, cut to length and install. Insert 4x 6 mm dia. washers between cover of fuel-tank sending unit and nut of fuel standpipe to adjust height.



Installing fuel standpipe

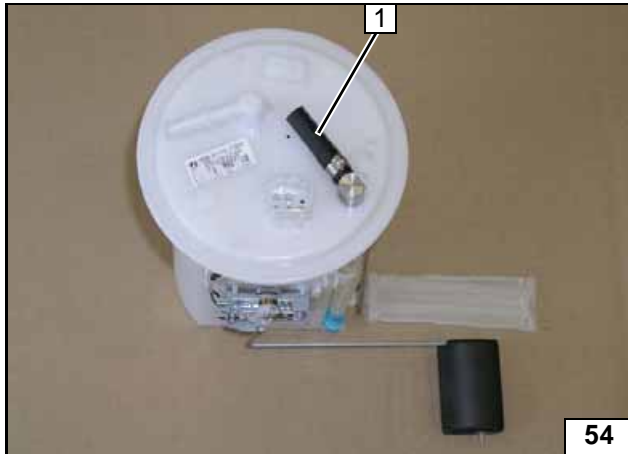

1 Hose section, 10 mm dia. Caillau clamp



Aligning fuel stand-pipe



Cut out mounting flange 1 in area of marking



Laying on mounting flange

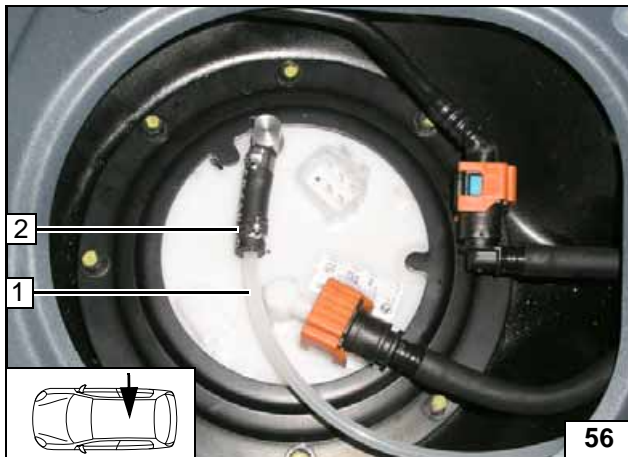

Install fuel-tank sending unit in accordance with manufacturer's instructions.

- 1 Fuel line
- 2 Hose section, 10 mm dia. Caillau clamp



Connect-ing fuel line



- 1 Angle bracket, M6x20 bolt, large diameter washer, flanged nut, existing hole
- 2 Fuel line of fuel standpipe

Installing angle bracket



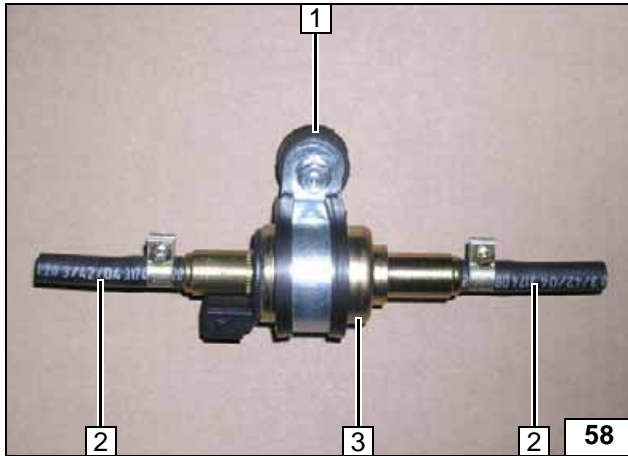

- 1 Silent block, rubber-coated p-clamp, flanged nut
- 2 Hose section, 10 mm dia. clamp [2x each]
- 3 Metering pump

Premounting metering pump

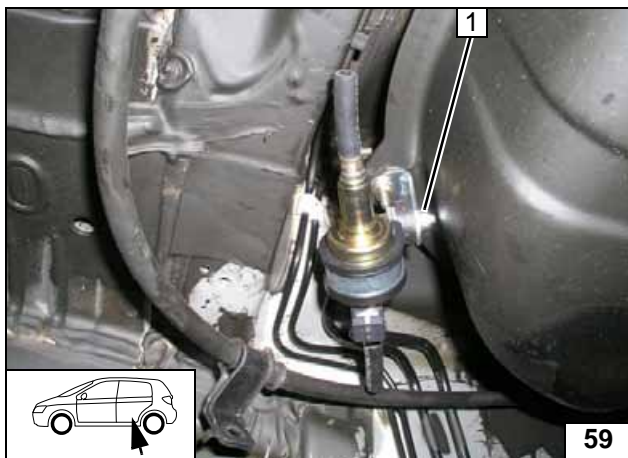

- 1 Flanged nut



Mounting metering pump



Check the position of the components; adjust if necessary. Check that they have freedom of movement.

- 1 Hose section (rub protection), cable tie [2x]
- 2 Fuel line of fuel standpipe
- 3 10 mm dia. clamp



Connecting fuel line

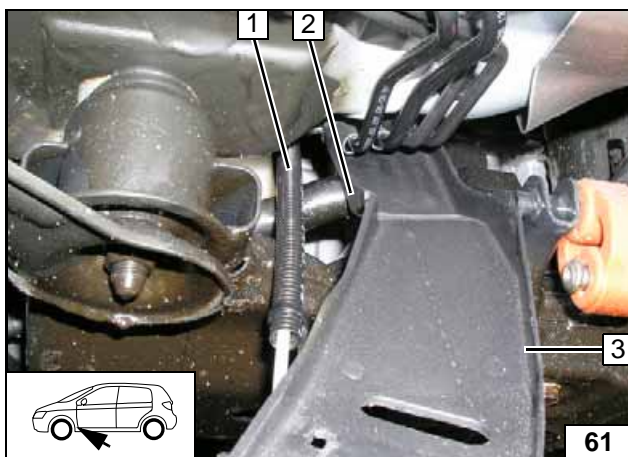

Detach line duct 3 and fold down, cut out edge at Pos. 2 for corrugated tube.

- 1 Fuel line of heater in corrugated tube



Cutting out line duct

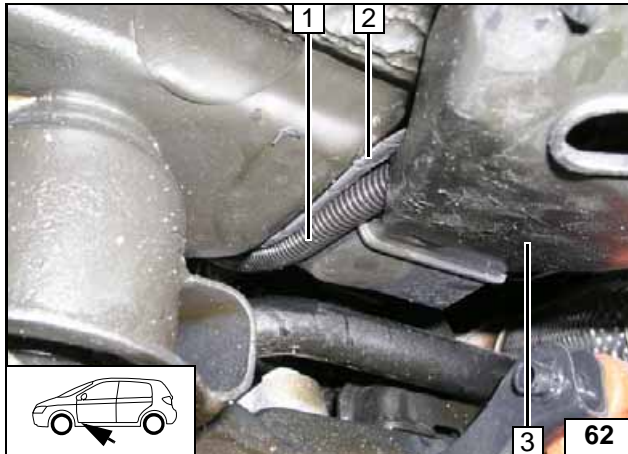

- 1 Fuel line in corrugated tube
- 2 Metering pump wiring harness
- 3 Line duct

**Routing lines into cover**

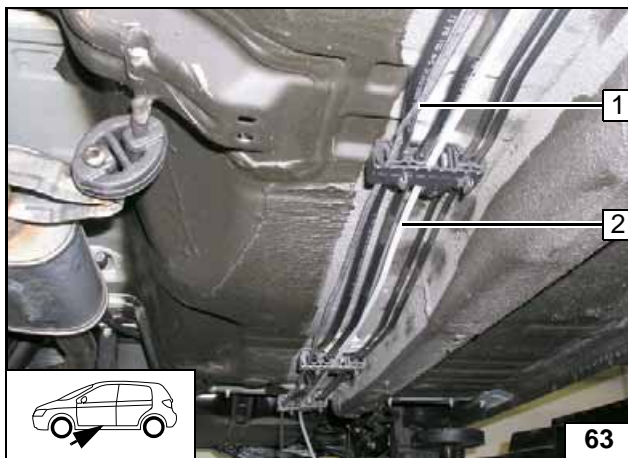

- 1 Metering pump wiring harness
- 2 Fuel line

**Installing lines on underbody**

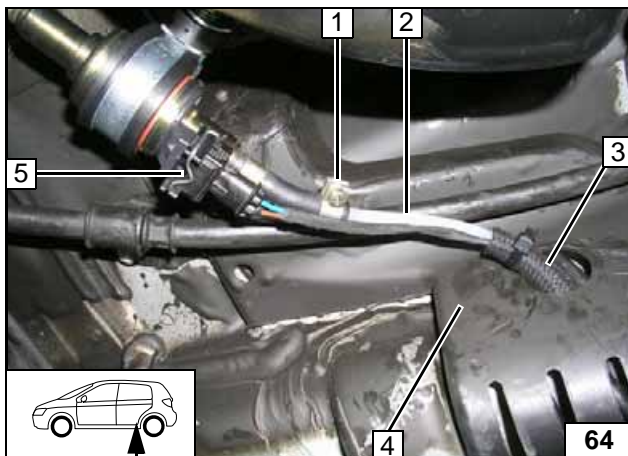

Check the position of the components; adjust if necessary. Check that they have freedom of movement.

- 1 10 mm dia. clamp
- 2 Fuel line of heater
- 3 Hose section (rub protection), cable tie [2x]
- 4 Installed line duct
- 5 Wiring harness of metering pump, connector mounted



**Connecting metering pump**

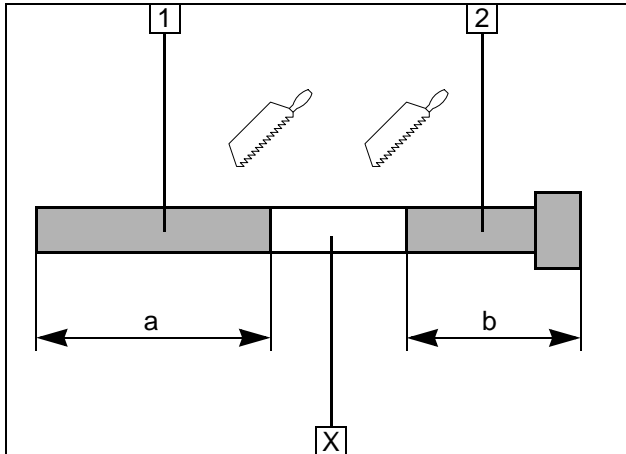
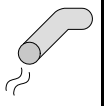

**Exhaust gas**

- 1 Exhaust pipe  
a = 340
- 2 Exhaust end section  
b = 190

Discard section X

**Preparing exhaust pipe**

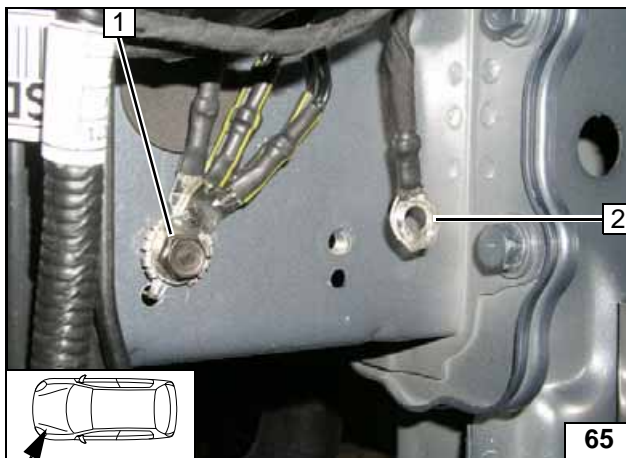

Detach earth cable 2 (bolt will be reused) and fasten to adjacent earth point 1.



**Moving earth wire**

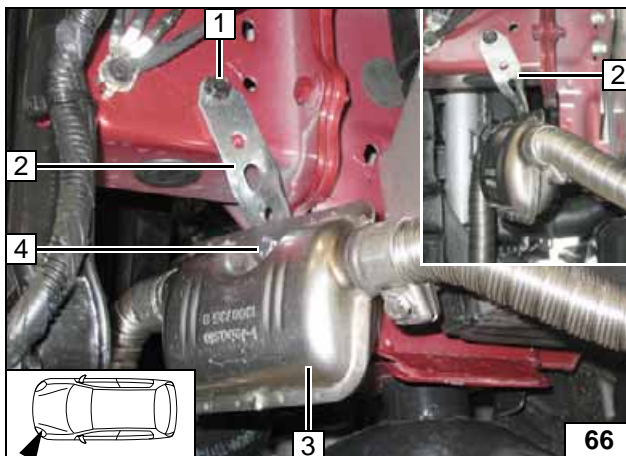

Twist perforated bracket 2 at the centre along the longitudinal axis by approx. 70°. Align exhaust silencer 3 correct, if necessary.

- 1 Original vehicle bolt
- 4 M6x20 bolt, flanged nut



**Mounting silencer**

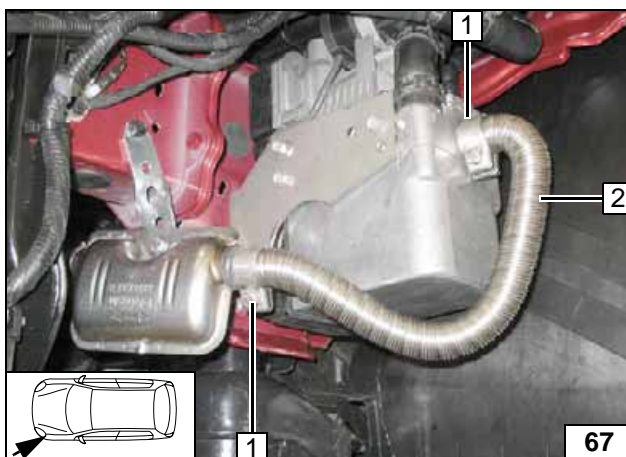

- 1 Hose clamp [2x]
- 2 Exhaust pipe

**Installing exhaust pipe**

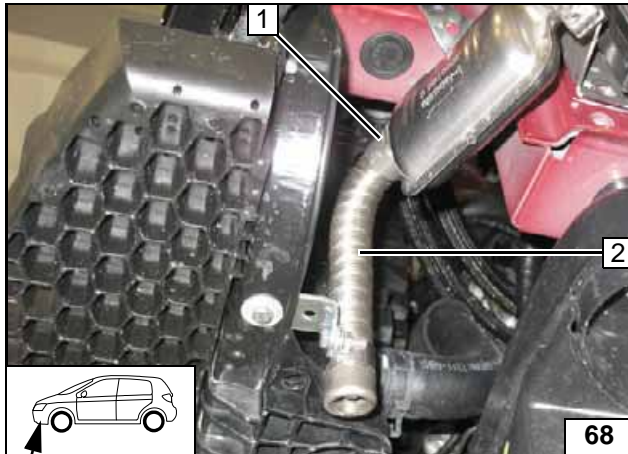
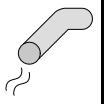

- 1 Hose clamp
- 2 Exhaust end section

**Installing  
exhaust  
end section**

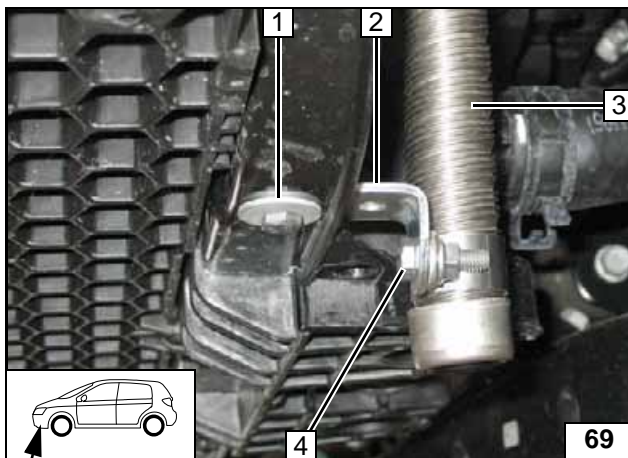

Check the position of the components; adjust if necessary. Check that they have freedom of movement.

- 1 M6x20 bolt, large diameter washer, flanged nut, existing hole
- 2 Angle bracket
- 3 Exhaust end section
- 4 M6x20 bolt, pipe clamp, flanged nut



**Fastening  
exhaust  
end section**

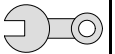

## Final Work

### WARNING!

Reassemble the components in reverse order. Check all hoses, clamps and all electrical connections for firm seating. Insulate all loose lines and tie back.

Only use manufacturer-approved coolant. Spray the heater components with anti-corrosion wax (Tectyl 100K, Order No. 111329).

- Connect the battery
- Fill and bleed the coolant circuit according to the vehicle manufacturer's specifications.
- Set the digital timer, teach telestart transmitter
- Make settings on A/C control panel according to the "Operating Instructions for End Customer".
- Place signboard "Switch off parking heater before refuelling" in the area of the filler neck
- See installation instructions for initial start-up and function test

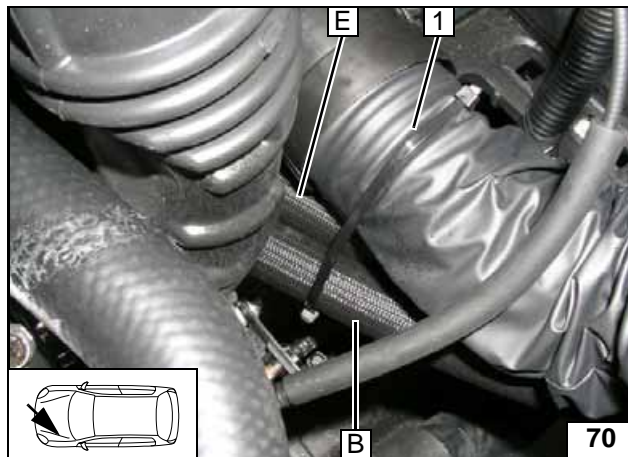

1 Cable tie

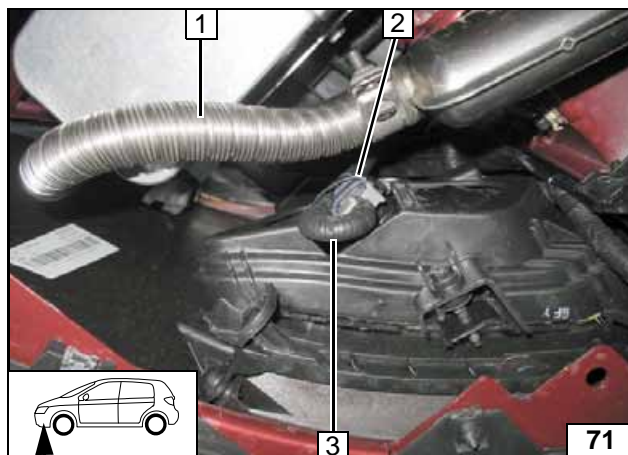

Secure wiring harness of fog light 3 with cable tie 2. Ensure sufficient distance to exhaust pipe 1.

Fastening hoses



Tying back wiring harness

**Webasto**  
Feel the drive

Webasto AG  
Postfach 80  
D-82132 Stockdorf / Germany  
National Hotline: 01805 93 22 78  
(14 Cent aus dem deutschen Festnetz)  
Hotfax: 0395 5592 353  
Hotmail: hotline@webasto.de  
<http://www.webasto.de>

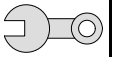

### Template for fuel standpipe

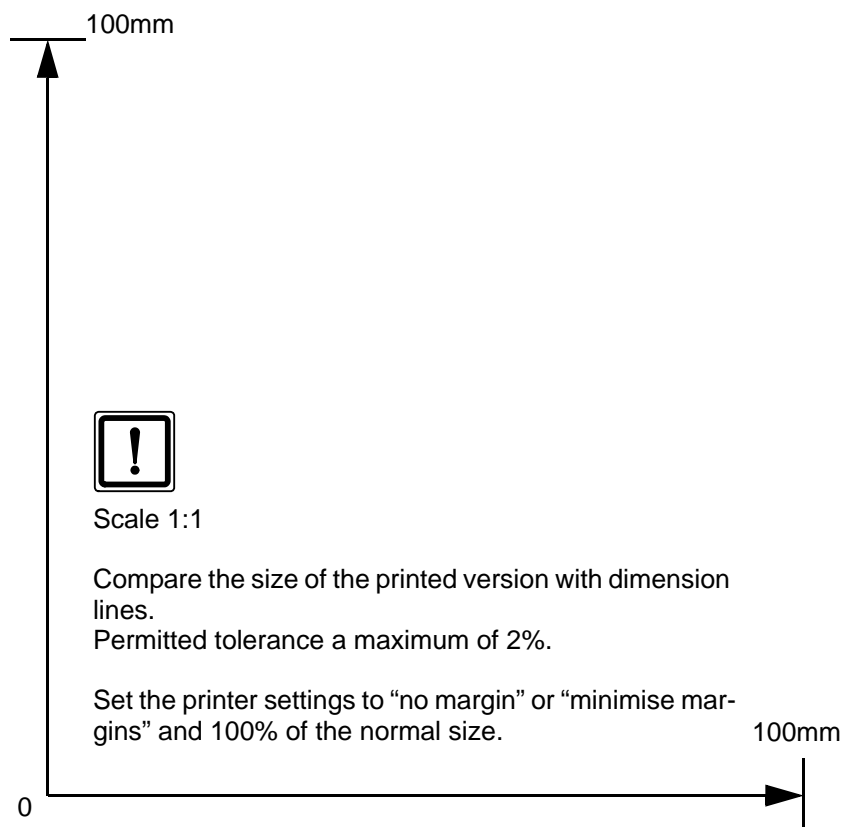

## Operating Instructions for the End Customer

Please remove page and add to the vehicle operating instructions.

### Note:

We recommend matching the heating time to the driving time.

Heating time = driving time

### Example:

For a driving time of approx. 20 min. (in one direction), we recommend not exceeding a switch-on time of 20 min.

The passenger compartment monitoring is to be disabled for vehicles with burglar alarm. For instructions on deactivation, please refer to the operating instructions of the vehicle.

Before parking the vehicle, make the following settings:

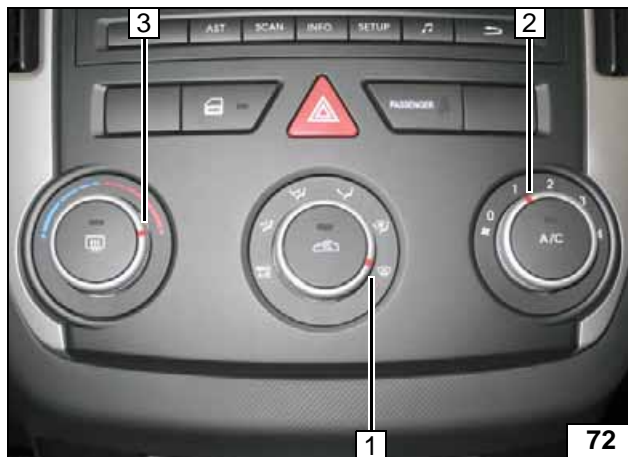

- 1 Air outlet to windscreen
- 2 Set fan to level "1", or possibly "2"
- 3 Set temperature to "max."



- 1 Air outlet faces "upward"
- 2 Set fan to level "1", or possibly "2"
- 3 Set temperature to "HI"

Manual air conditioning

Automatic air-conditioning