

# Water Heater

**Thermo Top Evo 5+ Parking Heater**  00 0258

## Installation Documentation Ford S-MAX / Galaxy / Mondeo (CD 34\*)

### Validity

Manufacturer	Model	Type	EG-BE-No. / ABE
Ford (D)	S-MAX	WA 6	e13 * 2001/116 * 0185 * ...
Ford (D)	Galaxy	WA 6	e13 * 2001/116 * 0185 * ...
Ford (D)	Mondeo	BA 7	e13 * 2001/116 * 0249 * ...

### S-MAX:

Motorisation	Fuel	Transmission type	Output in kW	Displacement in cm <sup>3</sup>	Engine code
1.6	Petrol	SG / AT	118	1596	JTWA
2.0	Petrol	SG / AT	107	1999	TBWA / TBWB
2.5	Petrol	SG / AT	162	2521	HUWA

### Galaxy:

Motorisation	Fuel	Transmission type	Output in kW	Displacement in cm <sup>3</sup>	Engine code
1.6	Petrol	SG / AT	118	1596	JTWA
2.0	Petrol	SG / AT	107	1999	TBWA / TBWB

### Mondeo:

Motorisation	Fuel	Transmission type	Output in kW	Displacement in cm <sup>3</sup>	Engine code
1.6	Petrol	SG / AT	88	1596	KGBA
1.6	Petrol	SG / AT	118	1596	JTBB
2.0	Petrol	SG / AT	107	1999	AOBA / AOBC
2.0	Petrol	SG / AT	149	1999	TNBA
2.0	Petrol	SG / AT	176	1999	PBBA
2.3	Petrol	SG / AT	118	2261	SEBA
2.5	Petrol	SG / AT	162	2521	HUBA

SG = manual transmission  
AT = automatic transmission

**Ford S-MAX / Galaxy from 2006 Model**

**Ford Mondeo (CD 34\*) from 2007 Model**

**Left-hand drive vehicle**

## Ford S-MAX / Galaxy / Mondeo (CD 34\*)

<b>Verified equipment variants:</b>	Automatic air-conditioning Front fog light Headlight washer system
<b>Not verified:</b>	Passenger compartment monitoring Start-Stop-System
<b>Total installation time:</b>	approx. 11.5 hours for S-Max and Galaxy approx. 9.5 hours for Mondeo

# Ford S-MAX / Galaxy / Mondeo (CD 34\*)

## Table of Contents

Validity	1	Preparing Heater	21
Necessary Components	3	Installing Heater	22
Installation Overview	3	Installing Exhaust System	22
Information on Total Installation Time	3	Fuel	24
Information on Operating and Installation Instructions	4	Coolant Circuit	29
Information on Validity	5	Final Work	33
Technical Information	5	Operating Instructions for End Customer	34
Explanatory Notes on Document	5		
Preliminary Work	6		
Heater Installation Location	6		
Preparing Electrical System	7		
Electrical System	8		
Control of Automatic Air-Conditioning Version A	9		
Control of Automatic Air-Conditioning Version B	12		
Control of Automatic Air-Conditioning Version C	15		
Digital Timer	18		
Remote Option (Telestart)	19		

## Necessary Components

- Delivery scope *Thermo Top Evo 5+* Ford (CD 34\*) Petrol: **1316398A**
- Heater control in accordance with price list and upon consultation with end customer
- In case of Telestart, indicator lamp in accordance with price list and in consultation with end customer

### Note:

To facilitate the installation, the vehicle should only be delivered with a quarter-full fuel tank.

## Installation Overview

### Legend:

1. Heater
2. Engine compartment fuse holder
3. Passenger compartment fuse holder
4. Circulating pump
5. Digital timer
6. Metering pump

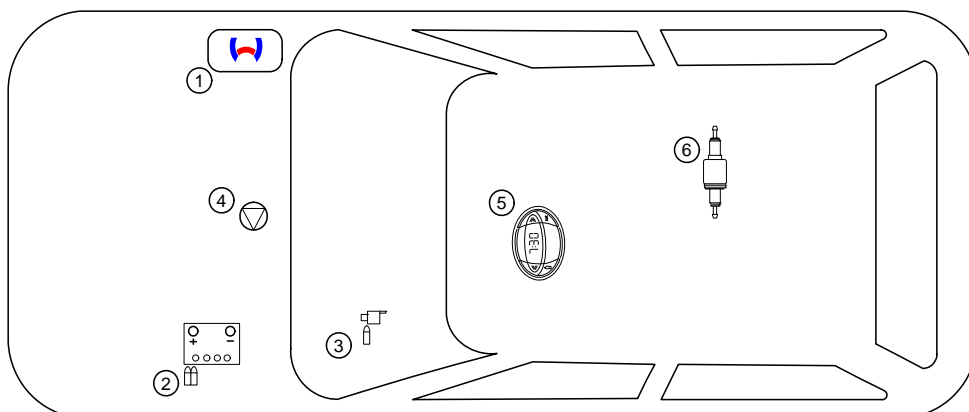

## Information on Total Installation Time

The total installation time includes the time needed for mounting and demounting of the vehicle-specific components, the heater specific installation time and all other times required for the system integration and initial start-up of the heater.

The total installation time may vary for vehicle equipment other than provided.

## Information on Operating and Installation Instructions

### 1 Important Information (not complete)

#### 1.1 Installation and Repair



The improper installation or repair of Webasto heating and cooling systems can cause fire or the leakage of deadly carbon monoxide, leading to serious injury or death.



To install and repair Webasto heating and cooling systems you need to have completed a special company training course and have the appropriate technical documentation, special tools and special equipment.



Installation and repair may ONLY be carried out by persons trained and certified in a Webasto training course. NEVER try to install or repair Webasto heating or cooling systems if you have not completed a Webasto training course, you do not have the necessary technical skills and you do not have the technical documentation, tools and equipment available to ensure that you can complete the installation and repair work properly.

Only use genuine Webasto parts. See the Webasto air and water heaters accessories catalogue for this purpose.

#### 1.2 Operation

To ensure safe operation, we recommend having the heater checked every two years by an authorised Webasto dealer, especially when used over a long period and/or under extreme environmental conditions.

Do not operate the heater in closed rooms due to the danger of poisoning and suffocation.

Always switch off the heater before refuelling.

The heater may only be used with the prescribed fuel Diesel (DIN EN 590) or petrol (DIN EN 227).

The heater may not be cleaned with a high-pressure cleaner.

#### 1.3 Please note

ALWAYS follow all Webasto installation and operating instructions and observe all warnings.

To become familiar with and understand all functions and properties of the heater, the operating instructions must be read carefully and observed at all times.

For proper, safe installation and repair work, the installation instructions with all warnings and safety information must be carefully read and observed at all times. Please always contact a workshop authorised by Webasto for all installation and repair work.

#### Important

**Webasto shall assume no liability for defects, damage and injuries resulting from a failure to observe the installation, repair and operating instructions of the information contained in them.**

**This liability exclusion particularly applies to improper installations and repairs, installations and repairs by untrained persons or in the case of a failure to use genuine spare parts.**

**The liability due to culpable disregard to life, limb or health and due to damage or injuries caused by a wilful or reckless breach of duty remain unaffected, as does the obligatory product liability.**

**Installation should be carried out according to the general, standard rules of technology. Unless specified otherwise, fasten hoses, lines and wiring harnesses to original vehicle lines and wiring harnesses using cable ties. Insulate loose wire ends and tie back. Connectors on electronic components must audibly snap into place during assembly.**

**Sharp edges should be fitted with rub protection. Spray unfinished body areas, e.g. drilled holes, with anti-corrosion wax (Tectyl 100K, Order No. 111329).**

**Observe the instructions and guidelines of the respective vehicle manufacturer for demounting and mounting vehicle specific components!**

**The initial startup is to be executed with the Webasto Thermo Test Diagnosis.**

**When installing an IPCU, the corresponding settings must be checked or adjusted before the installation.**

### 2 Statutory regulations governing installation

Guidelines	Thermo Top Evo
Heating Directive ECE R122	E1 00 0258
EMC Directive ECE R10	E1 03 5627

#### Note

The regulations of these guidelines are binding in the scope of the Directive 70/156/EEC and/or 2007/46/EC (for new vehicle models from 29/04/2009) and should also be observed in countries in which there are no special regulations.

#### Important

Failure to follow the installation instructions will result in the invalidation of the type approval for the heater and therefore invalidation of the general **homologation of the vehicle**.

#### Note

For vehicles with an EU permit, no entry in accordance with § 19 Sub-Section 4 of Annex VIII b to the Road Traffic Act is required.

### 2.1 Excerpt from the directive 2001/56/EC Appendix VII for the installation of the heater

Beginning of excerpt.

#### ANNEX VII

#### REQUIREMENTS FOR COMBUSTION HEATERS AND THEIR INSTALLATION

##### 1. GENERAL REQUIREMENTS

1.7.1. A clearly visible tell-tale in the operator's field of view shall inform when the combustion heater is switched on or off.

##### 2. VEHICLE INSTALLATION REQUIREMENTS

###### 2.1. Scope

2.1.1. Subject to paragraph 2.1.2. combustion heaters shall be installed according to the requirements of this Annex.

2.1.2. Vehicles of category O having liquid fuel heaters are deemed to comply with the requirements of this Annex.

###### 2.2. Positioning of heater

2.2.1. Body sections and any other components in the vicinity of the heater must be protected from excessive heat and the possibility of fuel or oil contamination.

2.2.2. The combustion heater shall not constitute a risk of fire, even in the case of overheating. This requirement shall be deemed to be fulfilled if the installation ensures an adequate distance to all parts and suitable ventilation, by the use of fire resistant materials or by the use of heat shields.

2.2.3. In the case of M2 and M3 vehicles, the heater must not be positioned in the passenger compartment. However, an installation in an effectively sealed envelope which also complies with the conditions in paragraph 2.2.2 may be used.

2.2.4. The label referred to in paragraph 1.4 or a duplicate, must be positioned so that it can be easily read when the heater is installed in the vehicle.

2.2.5. Every reasonable precaution should be taken in positioning the heater to minimise the risk of injury and damage to personal property.

###### 2.3. Fuel supply

2.3.1. The fuel filler must not be situated in the passenger compartment and must be provided with an effective cap to prevent fuel spillage.

2.3.2. In the case of liquid fuel heaters, where a supply separate to that of the vehicle is provided, the type of fuel and its filler point must be clearly labelled.

2.3.3. A notice, indicating that the heater must be shut down before refuelling, must be affixed to the fuelling point. In addition a suitable instruction must be included in the manufacturer's operating manual.

###### 2.4. Exhaust system

2.4.1. The exhaust outlet must be located so as to prevent emissions from entering the vehicle through ventilators, heated air inlets or opening windows.

###### 2.5. Combustion air inlet

2.5.1. The air for the combustion chamber of the heater must not be drawn from the passenger compartment of the vehicle.

2.5.2. The air inlet must be so positioned or guarded that blocking by rubbish or luggage is unlikely.

###### 2.6. Heating air inlet

2.6.1. The heating air supply may be fresh or recirculated air and must be drawn from a clean area not likely to be contaminated by exhaust fumes emitted either by the propulsion engine, the combustion heater or any other vehicle source.

2.6.2. The inlet duct must be protected by mesh or other suitable means.

###### 2.7. Heating air outlet

2.7.1. Any ducting used to route the hot air through the vehicle must be so positioned or protected that no injury or damage could be caused if it were to be touched.

2.7.2. The air outlet must be so positioned or guarded that blocking by rubbish or luggage is unlikely.

End of excerpt.

In multilingual versions the German language is binding.

# Ford S-MAX / Galaxy / Mondeo (CD 34\*)

## Information on Validity

This installation documentation applies to Ford S-Max / Galaxy Petrol vehicles from model year 2006 and later as well as Ford Mondeo (CD 34\*) petrol vehicles from model year 2007 and later - for validity, see page 1 - assuming technical modifications to the vehicle do not affect installation, any liability claims excluded. Depending on the vehicle version and equipment, modifications may be necessary during installation with respect to this installation documentation.

Vehicle and engine types, equipment variants and specifications not listed in this installation documentation have not been tested. However, installation according to this installation documentation may be possible.

## Technical Information

### Special Tools

- Hose clamp pliers for self-clamping hose clamps
- Hose clamp pliers for Clic hose clamps of type W
- Automatic wire stripper 0.2 - 6mm<sup>2</sup>
- Crimping pliers for cable lug / tab connector 0.5 - 6mm<sup>2</sup>
- Torque wrench for 2.0 - 10 Nm
- Hose clamping pliers
- Metric thread-setter kit
- Webasto Thermo Test diagnosis with current software

### Dimensions

- All dimensions are in mm

### Tightening torque values

- Tightening torque values of 5x13 heater bolts and 5x11 heater stud bolts = 8Nm.
- Tightening torque values of 5x15 retaining plate of water connection piece bolts = 7Nm.
- Tighten other bolt connections in accordance with manufacturer's instructions or in accordance with state-of-the-art- technology.

## Explanatory Notes on Document

You will find an identification mark on the outside top right corner of the page in question to provide you with a quick overview of the individual working steps.

Special features are highlighted using the following symbols:

### Mechanical system



### Electrical system



### Coolant circuit

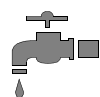

### Combustion air

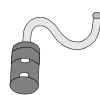

### Fuel

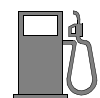

### Exhaust gas



### Software



### Specific risk of injury or fatal accidents



### Specific risk of damage to components



### Specific risk of fire and explosion



### Reference to general installation instructions of the Webasto components or to the manufacturer's vehicle-specific documents.



### Reference to a special technical feature



### The arrow in the vehicle icon indicates the position on the vehicle and the viewing angle

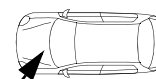
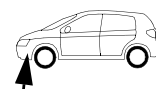

# Ford S-MAX / Galaxy / Mondeo (CD 34\*)

## Preliminary Work

### Vehicle

- Open the fuel tank cap.
- Ventilate the fuel tank.
- Close the fuel tank cap again.
- Disconnect the battery.
- Depressurise the cooling system.
- Mount the information sign on the cover of the diagnosis connection.
- Remove the engine design cover.
- Remove the battery and the battery carrier.
- Remove the air filter box.
- Remove the windscreen wipers (S-MAX and Galaxy only).
- Remove the coolant reservoir cap (S-MAX and Galaxy only).
- Remove the coolant reservoir trim in the engine compartment (S-MAX and Galaxy only).
- Remove the bracket of the coolant hoses (S-MAX and Galaxy only).
- Remove the right front wheel.
- Remove the wheel well trim on the right.
- Remove the lower engine cover (if present).
- Remove the cover of the fuel line under the vehicle.
- Remove the tank according to the manufacturer's instructions.
- Remove the fuel-tank sending unit in accordance with manufacturer's instructions.
- Remove the switch or trim strip above the A/C control panel/radio or A/C/navigation control unit [clipped in] (S-MAX and Galaxy only).
- Remove the cover of the centre console/shift lever cover.
- Remove the A/C control panel/radio or A/C/navigation control unit.
- Remove the glove compartment.
- Remove the cover of the A-pillar trim on the right (S-MAX and Galaxy only).
- Remove the lower instrument panel trim on the front passenger's side (Mondeo only).
- Detach the fuse box [SJB] and fold it down.

### Heater

- Remove years that do not apply from the type and duplicate label.
- Attach the duplicate label (type label) at the appropriate place in the engine compartment.

### Note

A fault may have been stored in the fault memory "Heating, ventilation and air-conditioning" by the operation of the parking heater. This must be deleted in accordance with the manufacturer's instructions during the vehicle inspection.

The installation location of the digital timer and push button are shown in the example and should be coordinated with the customer prior to installation.

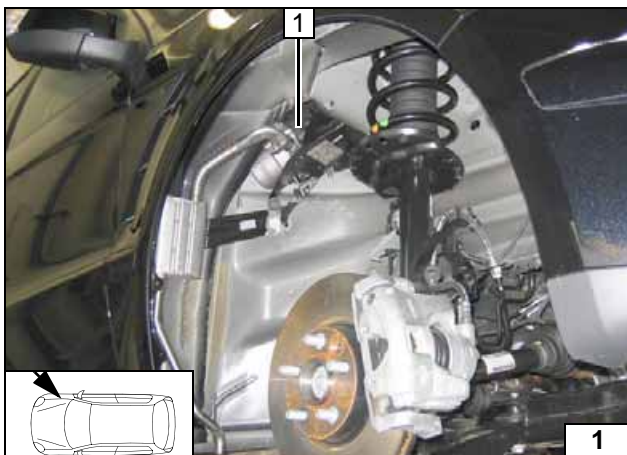

### Heater Installation Location

- 1 Heater

Installation  
location

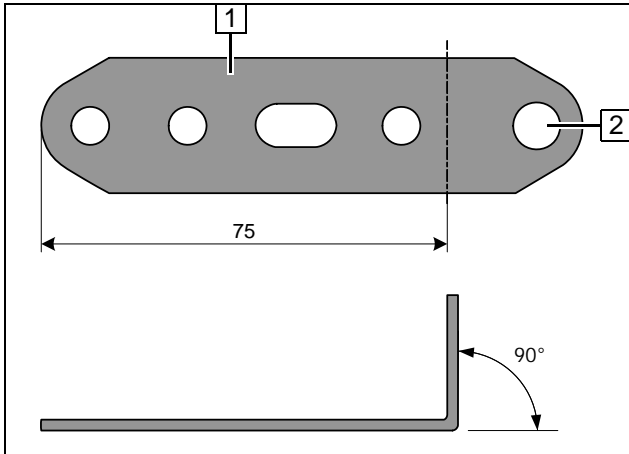

### Preparing Electrical System

Drill out hole at position 2 to 8.5 mm dia.

- 1 Perforated bracket



Angling down perforated bracket

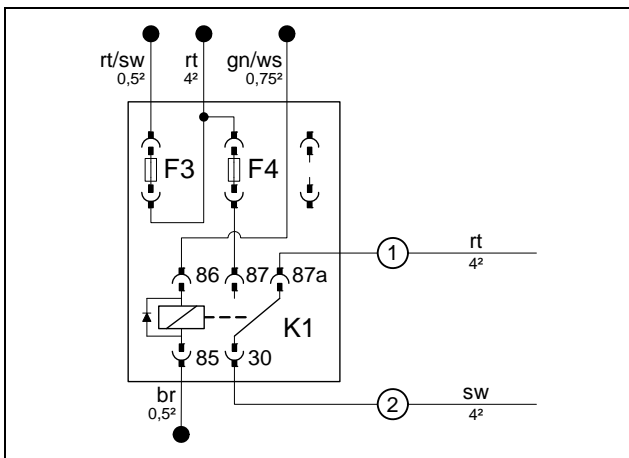

Wire sections retain their numbering in the entire document.

Insert 30A F4 into the fuse carrier.  
Insert red (rt) wire ① into K1/87a and black (sw) wire ② into K1/30.



Preparing K1 relay and fuse F4

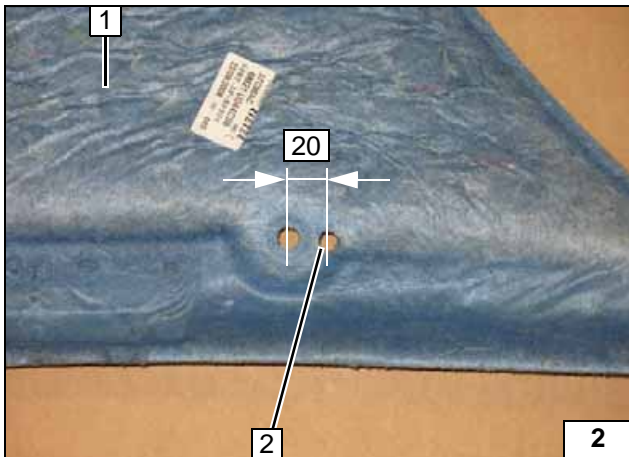

Punch 9mm dia. hole at position 2.

- 1 Trim of footwell on the driver's side



Hole in trim



## Electrical System

### Wiring harness pass through

- 1 Protective rubber plug

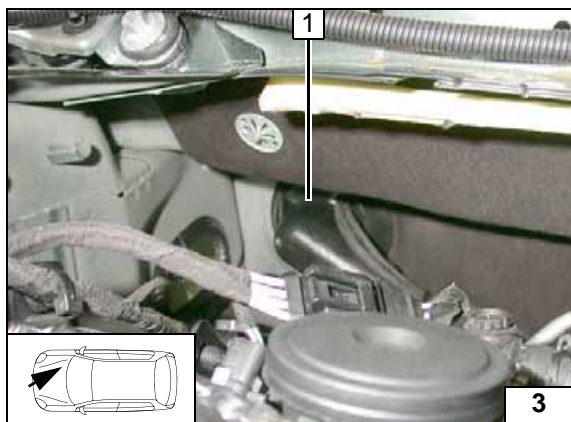

### Routing in engine compartment

- 1 Wiring harness of heater

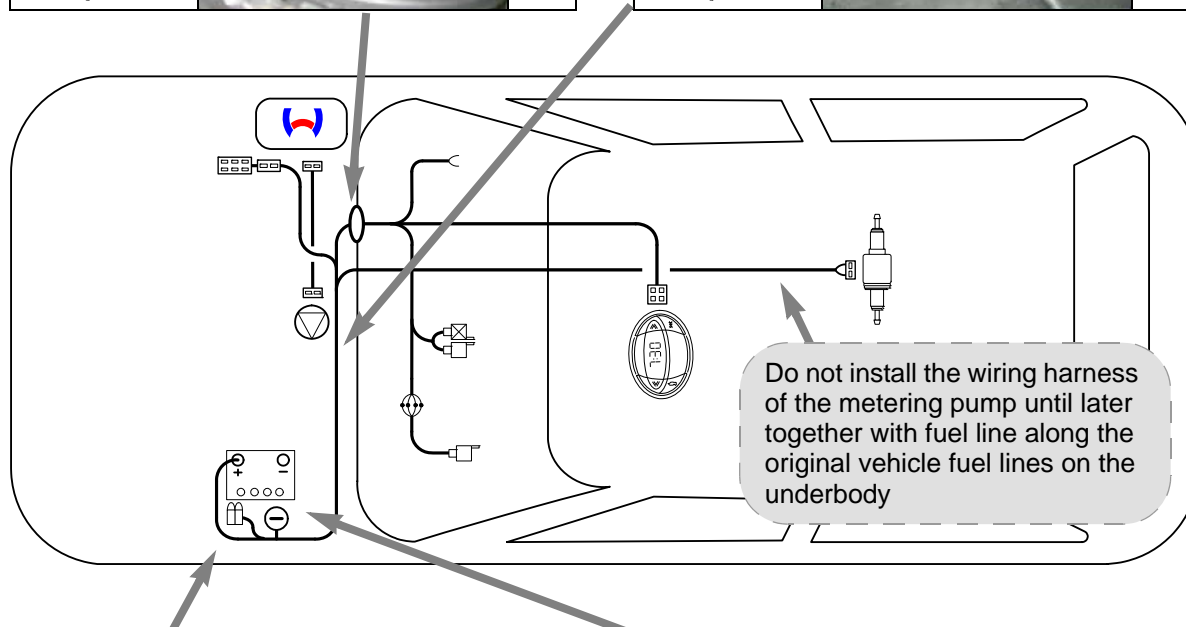
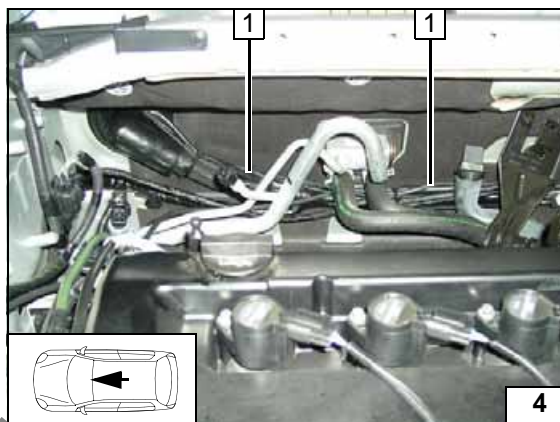
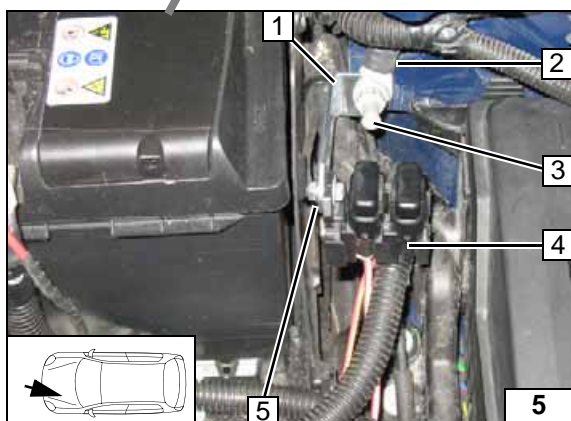
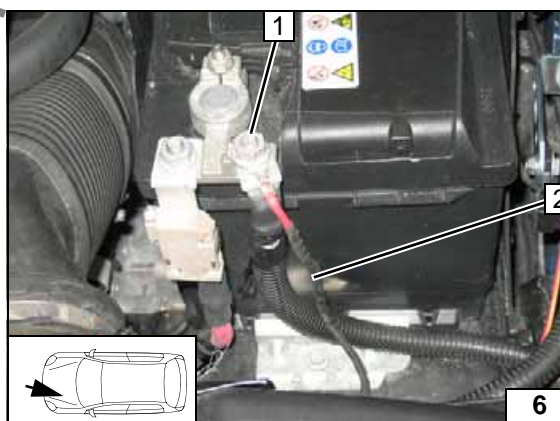

Diagram of wiring harness routing



Fuse holder of engine compartment, earth wire

- 1 Perforated bracket
- 2 Earth wire, 8mm dia. cable lug
- 3 Original vehicle earth point
- 4 Fuses F1-2
- 5 M5x12 bolt, large diameter washer, retaining plate of fuse holder, flanged nut



Positive wire

- 1 Connection of positive battery terminal
- 2 Positive wire, 8mm dia. cable lug





Control of Automatic Air-Conditioning Version A

Vehicle equipment if violet/green (vi/gn) wire is present on radio connector A, PIN 16.



Wiring diagram

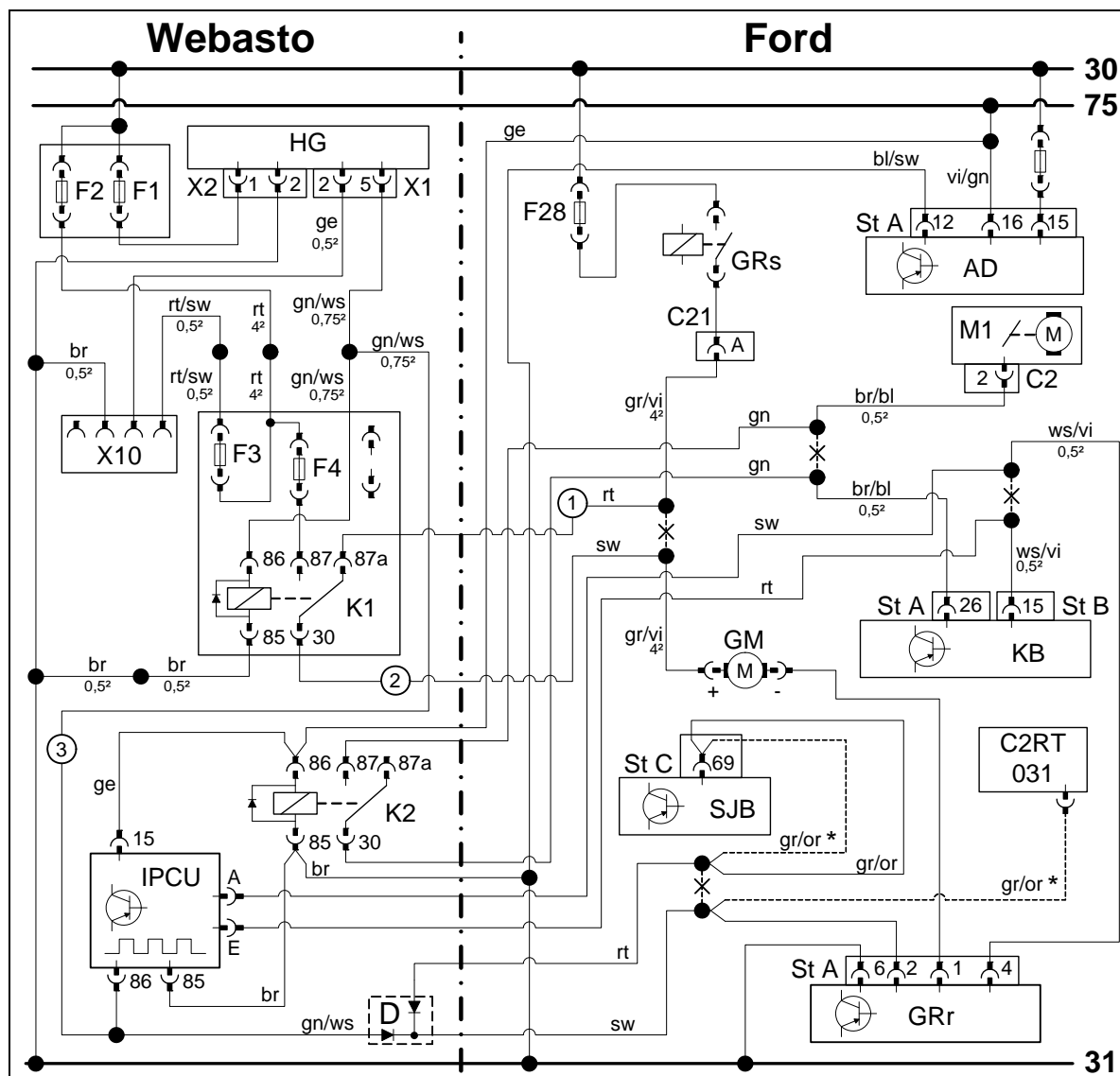

Webasto components		Vehicle components		Colours and symbols	
HG	Heater TT-Evo	F28	Fan fuse	rt	red
X1	6-pin heater connector	GRs	Fan relay	ws	white
X2	2-pin heater connector	AD	Radio	sw	black
K1	Fan relay	C21	Black connector	br	brown
K2	Additional relay	M1	Positioning motor of air flap	gn	green
F1	20A fuse	C2	M1 connector	bl	blue
F2	30A fuse	GM	Fan motor	ge	yellow
F3	1A fuse	KB	A/C control panel	vi	violet
F4	30A fuse	C2RT	Receiver WFS	gr	grey
X10	4-pin connector of heater control	SJB	Smart Junction Box		
IPCUC	Pulse width modulator	GRr	Fan controller		
<b>IPCUC adjustment values</b>		ST...	Plug connections		
Voltage: 10 V		*	depending on equipment	D	Diodes integrated in wiring harness
Frequency: 400 Hz				X	Cutting point
Duty cycle: 37 %					Wiring colours may vary.
Function: Low side					

Legend

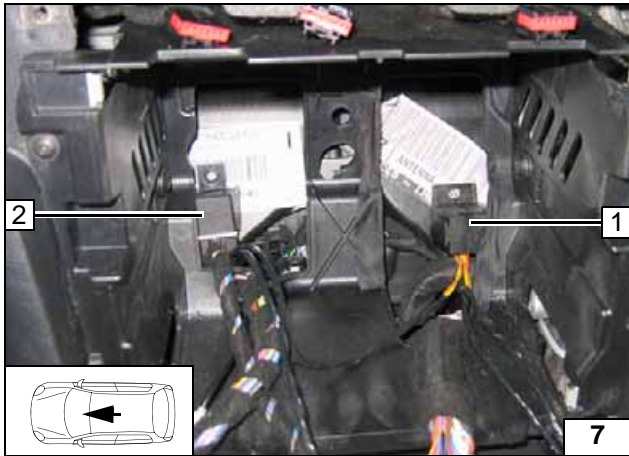

Fasten socket of K2 relay **2** and socket of IPCU **1** with double-sided adhesive tape as shown.  
Watch space requirement of A/C control unit or radio and their wiring harnesses.



**Installation of IPCU and K2 relay**

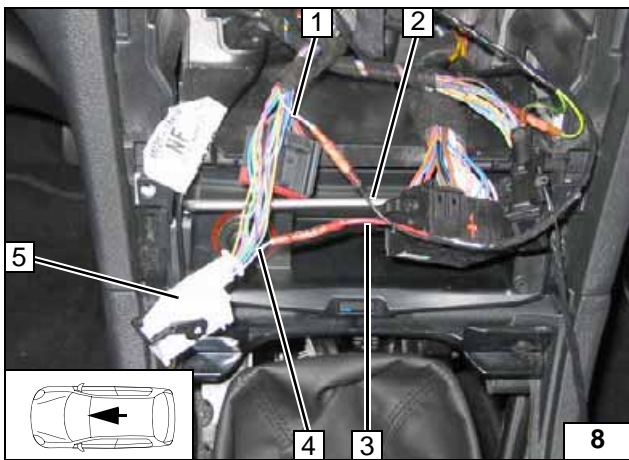

Connection on white (ws) connector B **5** from A/C control panel, Pin 15.  
Produce connections as shown in wiring diagram.



**Connection of A/C control panel / IPCU**

- 1 White/violet (ws/vi) wire of fan controller
- 2 Black (sw) wire of IPCU/A
- 3 Red (rt) wire of IPCU/E
- 4 White/violet (ws/vi) wire from connector of A/C control panel

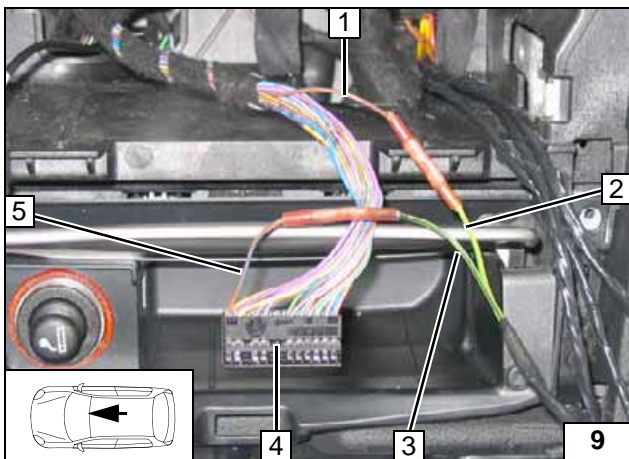

Connection on black (sw) connector A **4** of A/C control panel, Pin 26.  
Produce connections as shown in wiring diagram.



**Connection of A/C control panel / K2 relay**

- 1 Brown/blue (br/bl) wire of flap positioning motor
- 2 Green (gn) wire of K2/87
- 3 Green (gn) wire of K2/30
- 5 Brown/blue (br/bl) wire of A/C control panel connector

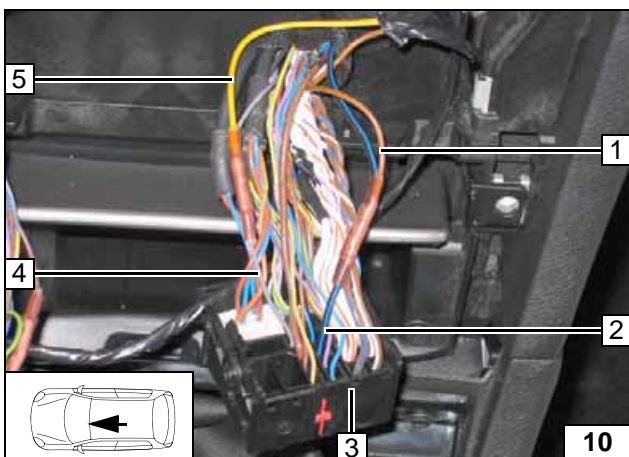

Connection on radio plug **3**, Pin 16.  
Produce connections as shown in wiring diagram.



**Connecting K2 relay to radio**

- 1 Brown (br) wire of K2/85
- 2 Black/blue (sw/bl) wire (earth)
- 4 Violet/green (vi/gn) wire (Terminal 75)
- 5 Yellow (ge) wire of K2/86

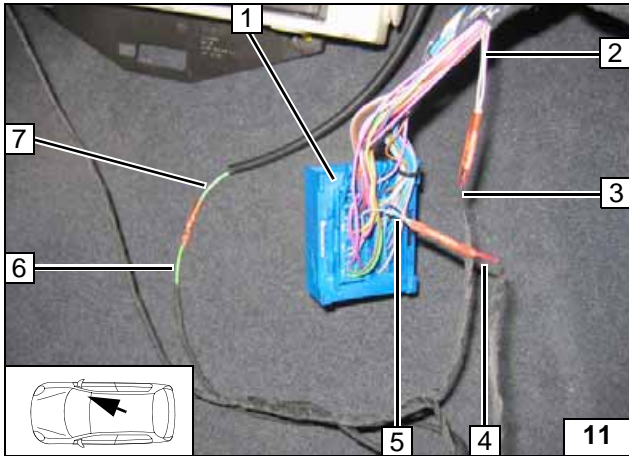
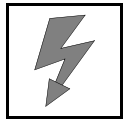

Connection on blue (bl) connector SJB 1, Pin 69. Produce connections as shown in wiring diagram. Depending on vehicle equipment, two cables may be present on Pin 69. Route green/white (gn/ws) additional wire ③ 7 to the left side of the vehicle.



**Connec-  
tion of SJB  
connector**

- 2 Grey/orange (gr/or) wire to fan controller (see wiring diagram)
- 3 Black (sw) wire of diode group
- 4 Red (rt) wire of diode group
- 5 Grey/orange (gr/or) wire to SJB connector (see wiring diagram)
- 6 Green/white (gn/ws) wire of IPCU wiring harness

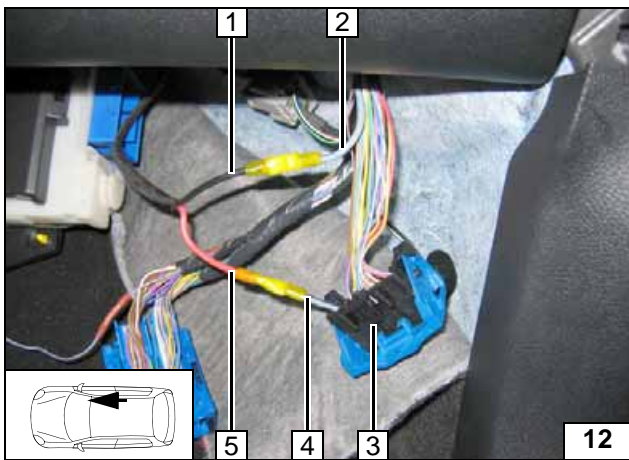

Connection to black (sw) connector C21 3 Pin A. Produce connections as shown in wiring diagram.



**Connect-  
ing fan mo-  
tor**

- 1 Black (sw) wire ② of K1/30
- 2 Grey/violet (gr/vi) wire of fan motor
- 4 Grey/violet (gr/vi) wire of connector C21
- 5 Red (rt) wire ① of K1/87a

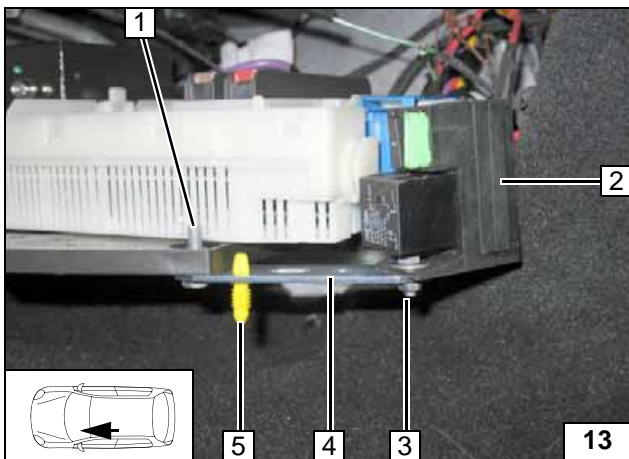

Remove plastic stud bolt at position 1 and insert it into perforated bracket 4 at position 5.



**Mounting  
fuse holder  
of passen-  
ger com-  
partment**

- 1 M6x20 bolt, flanged nut, existing hole
- 2 Fuse holder of passenger compartment
- 3 M5x12 bolt, large diameter washer, flanged nut

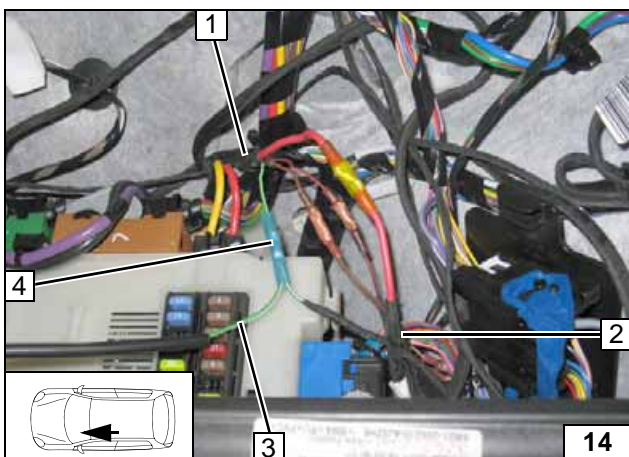

Connect wiring harnesses of the engine compartment fuse holder 1 and the passenger compartment fuse holder 2 in accordance with the wiring diagram and using same-colour wires. Separate red (rt) connector at position 4. Connect green/white (gn/ws) additional wire ③ 3 with blue (bl) connector at position 4 to green/white (gn/ws) wire.



**Connect-  
ing wiring  
harnesses**

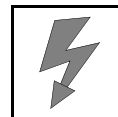

Control of Automatic Air-Conditioning Version B

Vehicle equipment if violet/green (vi/gn) wire is not present on radio connector A, PIN 16.



Wiring diagram

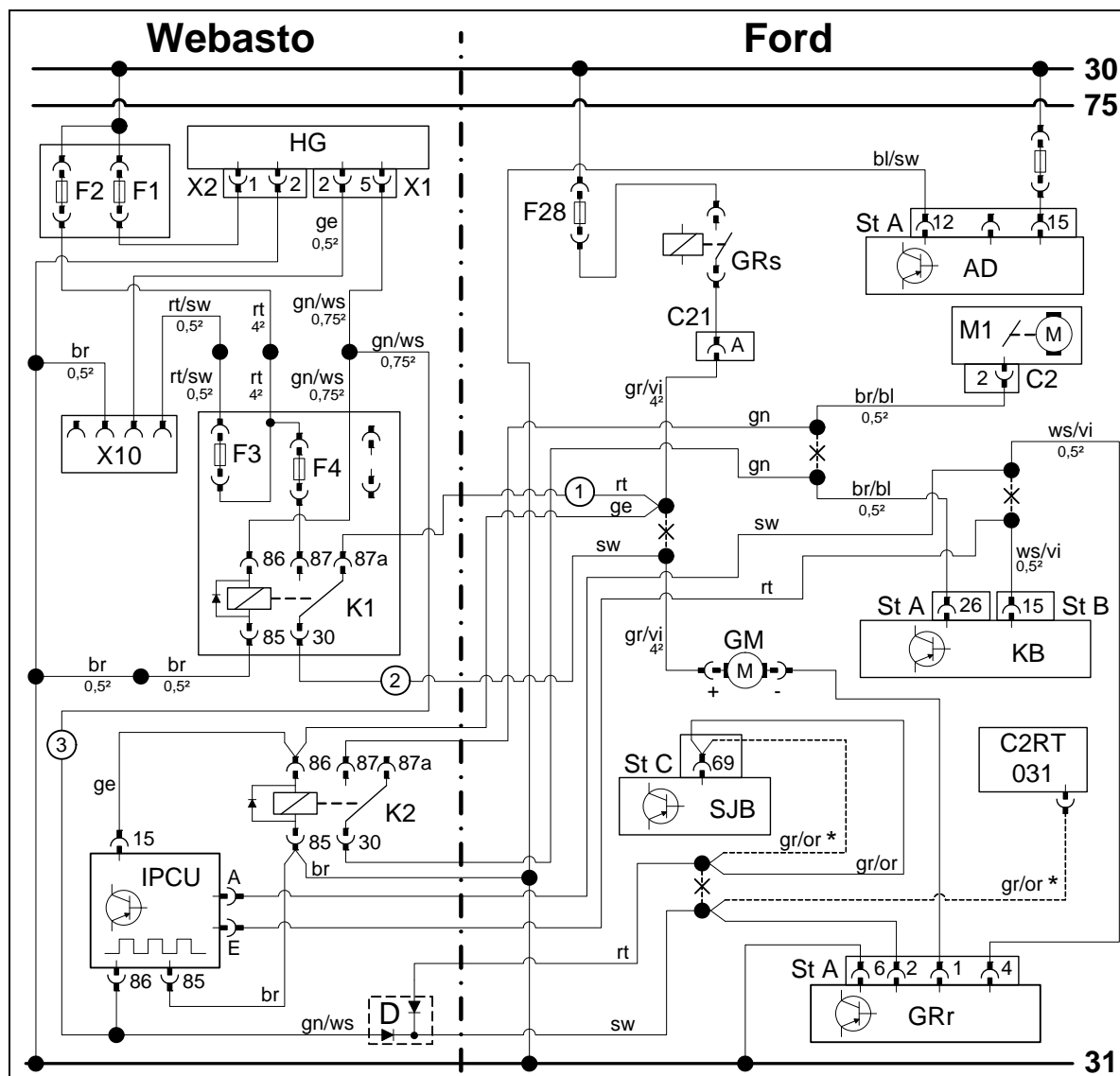

Webasto components		Vehicle components		Colours and symbols	
HG	Heater TT-Evo	F28	Fan fuse	rt	red
X1	6-pin heater connector	GRs	Fan relay	ws	white
X2	2-pin heater connector	AD	Radio	sw	black
K1	Fan relay	C21	Black connector	br	brown
K2	Additional relay	M1	Positioning motor of air flap	gn	green
F1	20A fuse	C2	M1 connector	bl	blue
F2	30A fuse	GM	Fan motor	ge	yellow
F3	1A fuse	KB	A/C control panel	vi	violet
F4	30A fuse	C2RT 031	Receiver WFS	gr	grey
X10	4-pin connector of heater control	SJB	Smart Junction Box		
IPCUC	Pulse width modulator	GRr	Fan controller		
<b>IPCUC adjustment values</b>		ST...	Plug connections		
Voltage: 10 V		*	depending on equipment	D	Diodes integrated in wiring harness
Frequency: 400 Hz				X	Cutting point
Duty cycle: 37 %					Wiring colours may vary.
Function: Low side					

Legend

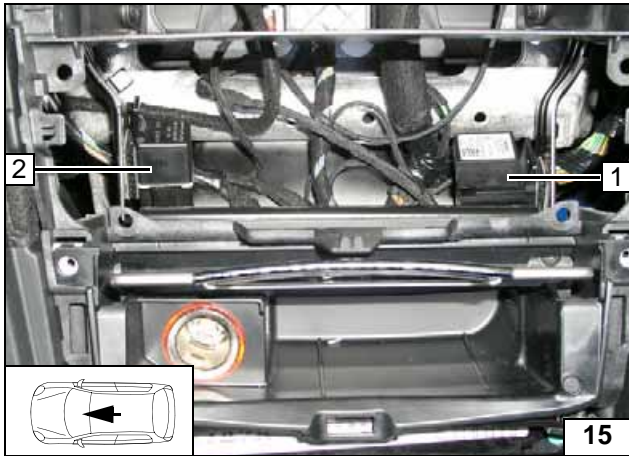

Fasten socket of K2 relay **2** and socket of IPCU **1** with double-sided adhesive tape as shown.  
Watch space requirement of A/C control unit or radio and their wiring harnesses.



**Installation of IPCU and K2 relay**

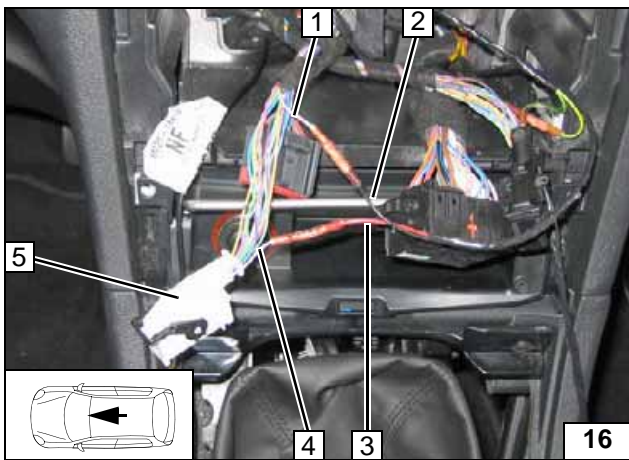

Connection on white (ws) connector B **5** from A/C control panel, Pin 15.  
Produce connections as shown in wiring diagram.



**Connection of A/C control panel / IPCU**

- 1** White/violet (ws/vi) wire of fan controller
- 2** Black (sw) wire of IPCU/A
- 3** Red (rt) wire of IPCU/E
- 4** White/violet (ws/vi) wire from connector of A/C control panel

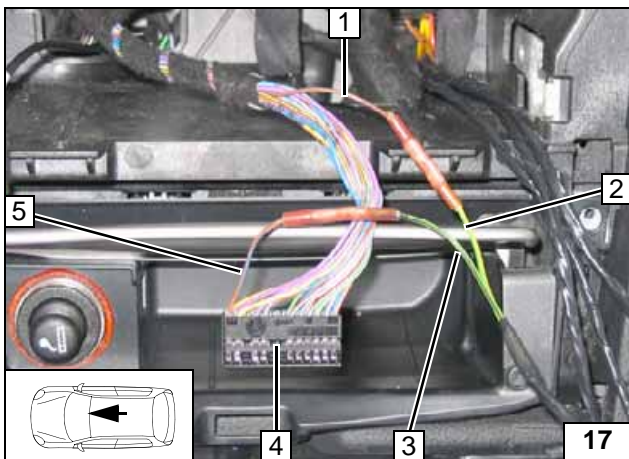

Connection on black (sw) connector A **4** of A/C control panel, Pin 26.  
Produce connections as shown in wiring diagram.



**Connection of A/C control panel / K2 relay**

- 1** Brown/blue (br/bl) wire of flap positioning motor
- 2** Green (gn) wire of K2/87
- 3** Green (gn) wire of K2/30
- 5** Brown/blue (br/bl) wire of A/C control panel connector

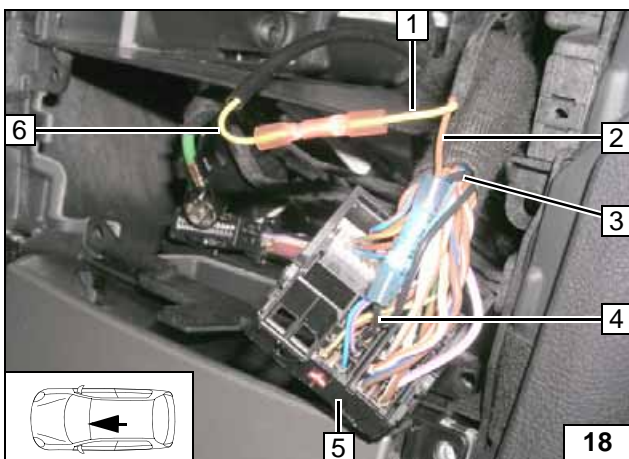

Connection on radio plug **5**.  
Produce connections as shown in wiring diagram.  
Connect yellow (ge) wire **1** from K2/86 to yellow (ge) wire **6** and route in protective sleeving into footwell on front passenger's side.



**Connection of K3.1/85 on radio**

- 2** Brown (br) wire of K2/85
- 3** Black/blue (sw/bl) wire (earth)
- 4** Black/blue (sw/bl) wire (earth) from connector Pin 12

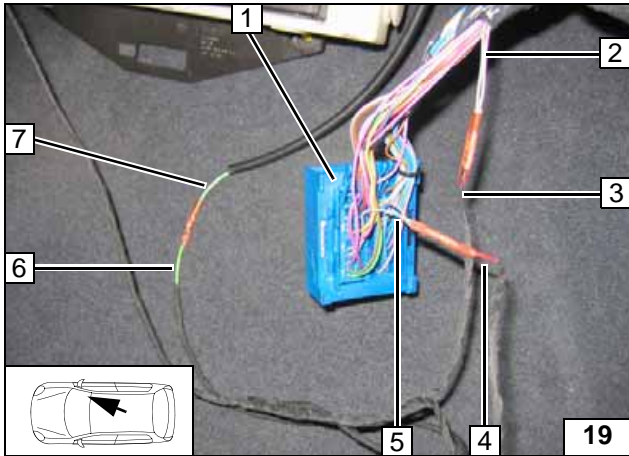

Connection on blue (bl) connector SJB 1, Pin 69. Produce connections as shown in wiring diagram. Depending on vehicle equipment, two cables may be present on Pin 69. Route green/white (gn/ws) additional wire ③ 7 to the left side of the vehicle.



**Connec-  
tion of SJB  
connector**

- 2 Grey/orange (gr/or) wire to fan controller (see wiring diagram)
- 3 Black (sw) wire of diode group
- 4 Red (rt) wire of diode group
- 5 Grey/orange (gr/or) wire to SJB connector (see wiring diagram)
- 6 Green/white (gn/ws) wire of IPCU wiring harness

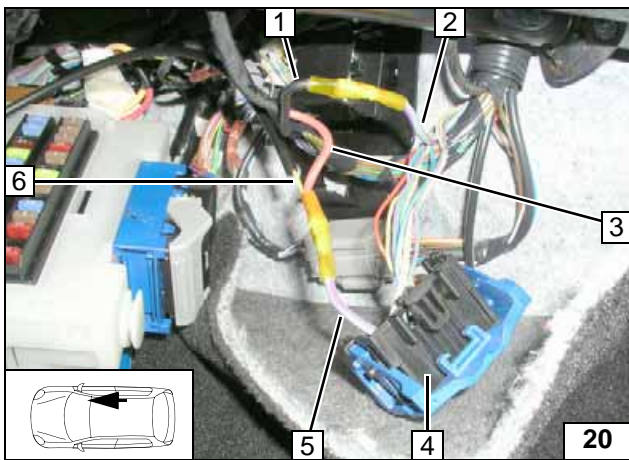

Connection to black (sw) connector C21 4 Pin A. Produce connections as shown in wiring diagram.



**Connect-  
ing fan mo-  
tor**

- 1 Black (sw) wire ② of K1/30
- 2 Grey/violet (gr/vi) wire of fan motor
- 3 Red (rt) wire ① of K1/87a
- 5 Grey/violet (gr/vi) wire of connector C21
- 6 Yellow (ge) wire of K2/86 relay

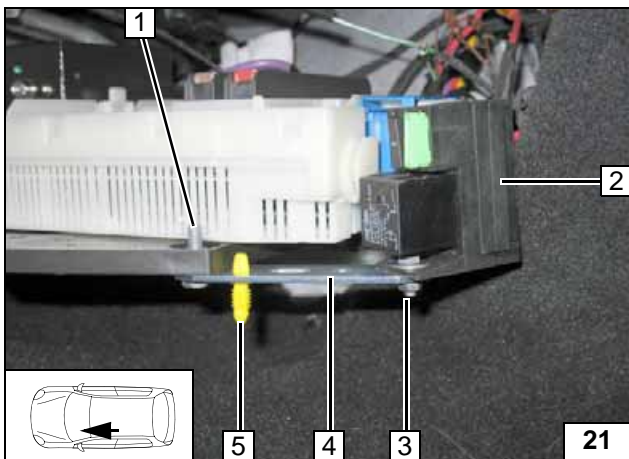

Remove plastic stud bolt at position 1 and insert it into perforated bracket 4 at position 5.



**Mounting  
fuse holder  
of passen-  
ger com-  
partment**

- 1 M6x20 bolt, flanged nut, existing hole
- 2 Fuse holder of passenger compartment
- 3 M5x12 bolt, large diameter washer, flanged nut

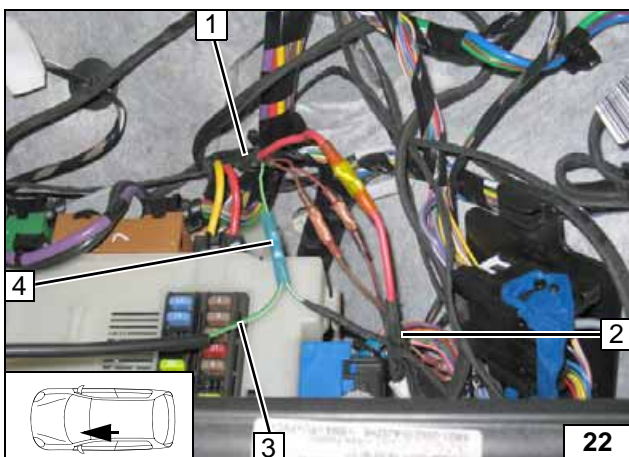

Connect wiring harnesses of the engine compartment fuse holder 1 and the passenger compartment fuse holder 2 in accordance with the wiring diagram and using same-colour wires. Separate red (rt) connector at position 4. Connect green/white (gn/ws) additional wire ③ 3 with blue (bl) connector at position 4 to green/white (gn/ws) wire.



**Connect-  
ing wiring  
harnesses**



Control of Automatic Air-Conditioning Version C

Starting with model year 2010.



Wiring diagram

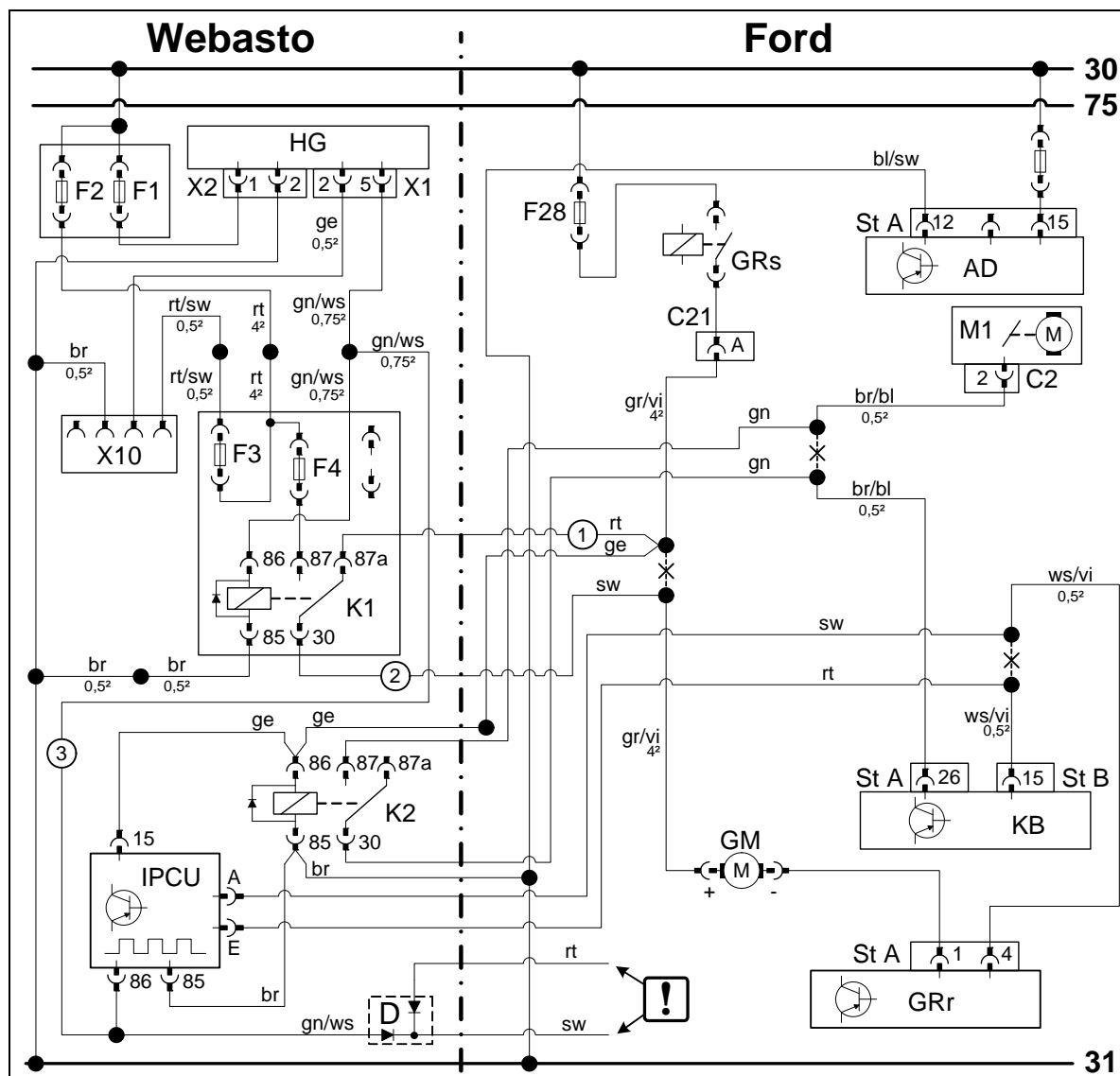

Webasto components		Vehicle components		Colours and symbols	
HG	Heater TT-Evo	F28	Fan fuse	rt	red
X1	6-pin heater connector	GRs	Fan relay	ws	white
X2	2-pin heater connector	AD	Radio	sw	black
K1	Fan relay	C21	Black connector	br	brown
K2	Additional relay	M1	Positioning motor of air flap	gn	green
F1	20A fuse	C2	M1 connector	bl	blue
F2	30A fuse	KB	A/C control panel	ge	yellow
F3	1A fuse	GM	Fan motor	vi	violet
F4	30A fuse	GRr	Fan controller	gr	grey
X10	4-pin connector of heater control	ST...	Plug connections		
IPCU	Pulse width modulator				Insulate wire ends and tie back
<b>IPCU adjustment values</b>				D	Diodes integrated in wiring harness
Voltage: 10 V				X	Cutting point
Frequency: 400 Hz					
Duty cycle: 37 %					
Function: Low side					Wiring colours may vary.

Legend

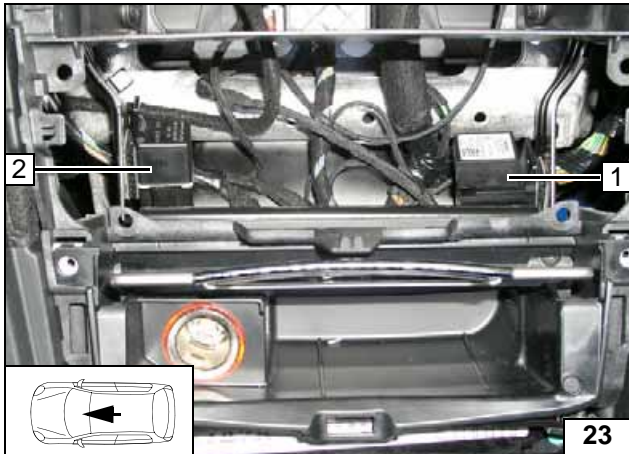

Fasten socket of K2 relay **2** and socket of IPCU **1** with double-sided adhesive tape as shown.

Watch space requirement of A/C control unit or radio and their wiring harnesses. Route green/white (gn/ws) wire of IPCU (IPCU/86) wiring harness to the left side of the vehicle. Insulate red (rt) and black (sw) wires and tie them back.



**Installation of IPCU and K2 relay**

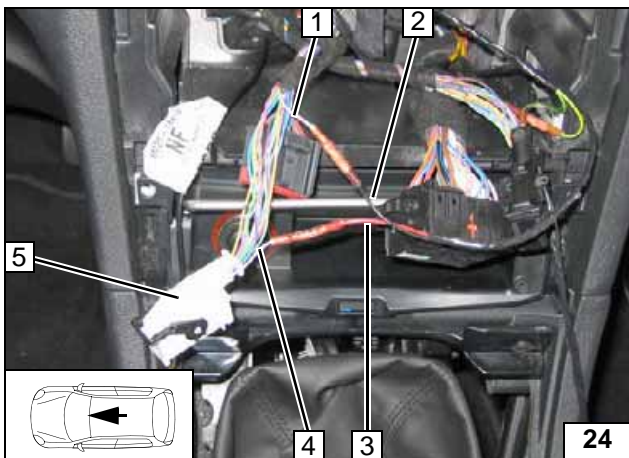

Connection on white (ws) connector B **5** from A/C control panel, Pin 15.

Produce connections as shown in wiring diagram.

- 1** White/violet (ws/vi) wire of fan controller
- 2** Black (sw) wire of IPCU/A
- 3** Red (rt) wire of IPCU/E
- 4** White/violet (ws/vi) wire from connector of A/C control panel



**Connection of A/C control panel / IPCU**

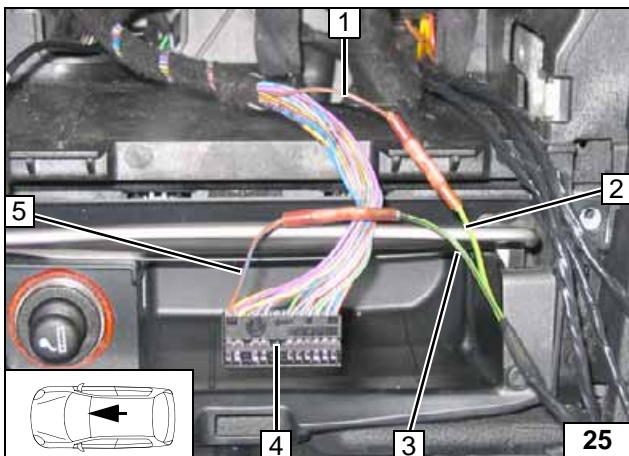

Connection on black (sw) connector A **4** of A/C control panel, Pin 26.

Produce connections as shown in wiring diagram.

- 1** Brown/blue (br/bl) wire of flap positioning motor
- 2** Green (gn) wire of K2/87
- 3** Green (gn) wire of K2/30
- 5** Brown/blue (br/bl) wire of A/C control panel connector



**Connection of A/C control panel / K2 relay**

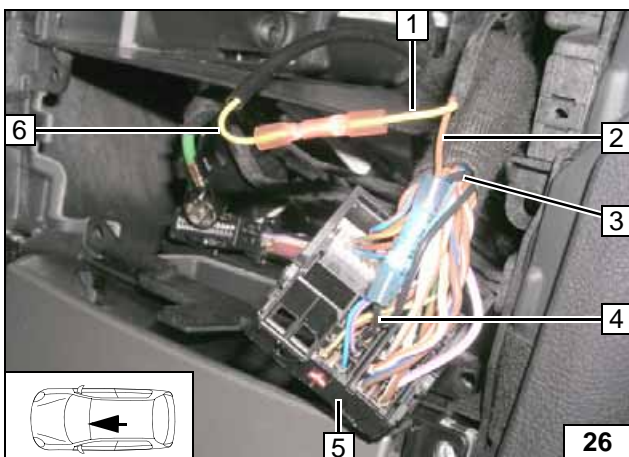

Connection on radio plug **5**.

Produce connections as shown in wiring diagram.

Connect yellow (ge) wire **1** from K2/86 to yellow (ge) wire **6** and route in protective sleeving into footwell on front passenger's side.

- 2** Brown (br) wire of K2/85
- 3** Black/blue (sw/bl) wire (earth)
- 4** Black/blue (sw/bl) wire (earth) from connector Pin 12



**Connection of K3.1/85 on radio**



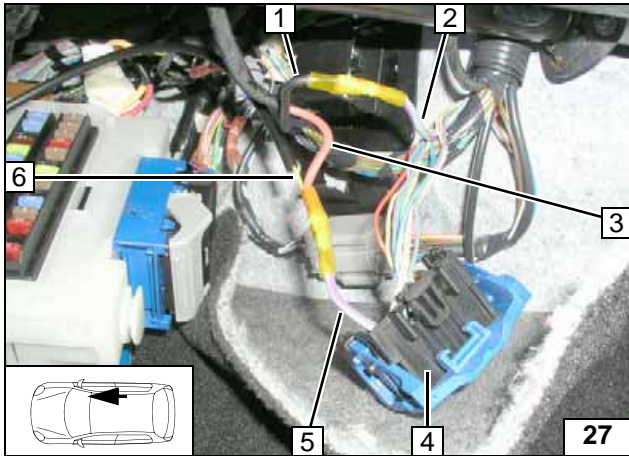

Connection to black (sw) connector C21 4 Pin A. Produce connections as shown in wiring diagram.

- 1 Black (sw) wire ② of K1/30
- 2 Grey/violet (gr/vi) wire of fan motor
- 3 Red (rt) wire ① of K1/87a
- 5 Grey/violet (gr/vi) wire of connector C21
- 6 Yellow (ge) wire of K2/86 relay



**Connect-  
ing fan mo-  
tor**

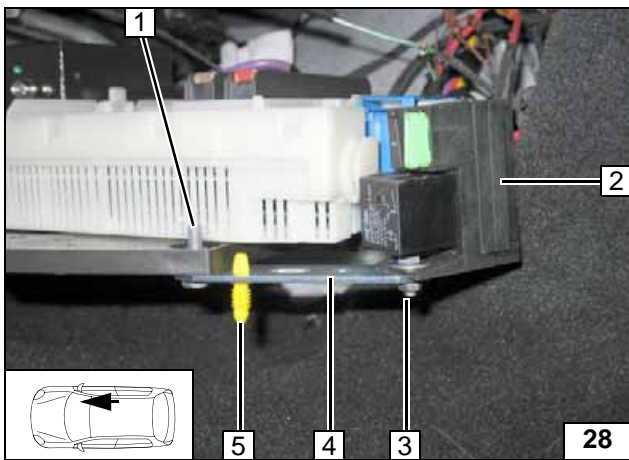

Remove plastic stud bolt at position 1 and insert it into perforated bracket 4 at position 5.

- 1 M6x20 bolt, flanged nut, existing hole
- 2 Fuse holder of passenger compartment
- 3 M5x12 bolt, large diameter washer, flanged nut



**Mounting  
fuse holder  
of passen-  
ger com-  
partment**

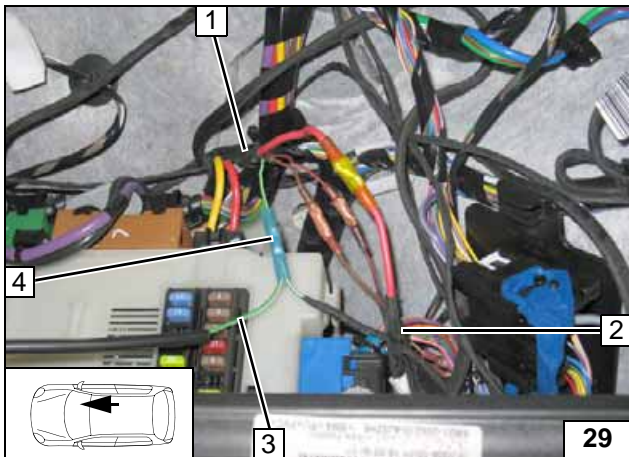

Connect wiring harnesses of the engine compartment fuse holder 1 and the passenger compartment fuse holder 2 in accordance with the wiring diagram and using same-colour wires. Separate red (rt) connector at position 4. Connect green/white (gn/ws) additional wire ③ 3 with blue (bl) connector at position 4 to green/white (gn/ws) wire.



**Connect-  
ing wiring  
harnesses**



**Digital Timer**

**Version A**  
**S-MAX / Galaxy up to MY 2009**

1 Digital timer

**Installing digital timer**

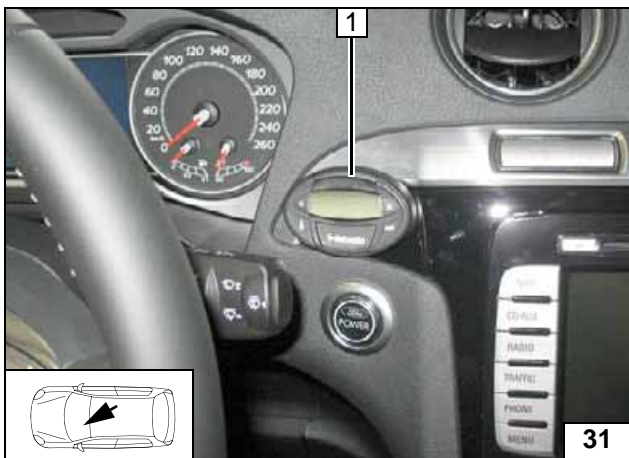

**Version A**  
**S-MAX / Galaxy starting with MY 2010**

1 Digital timer

**Installing digital timer**

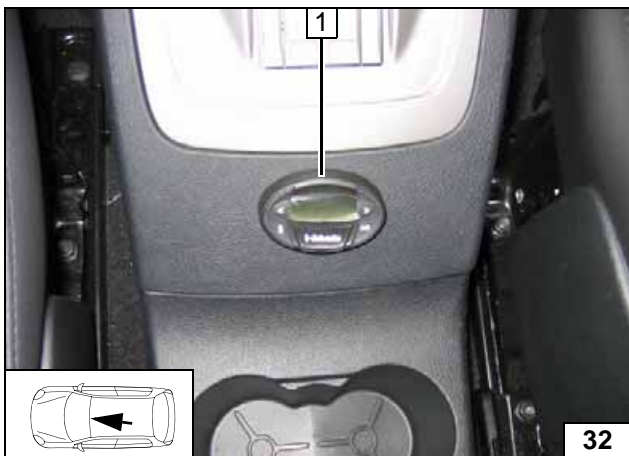

**S-MAX / Galaxy Version B**

1 Digital timer

**Installing digital timer**

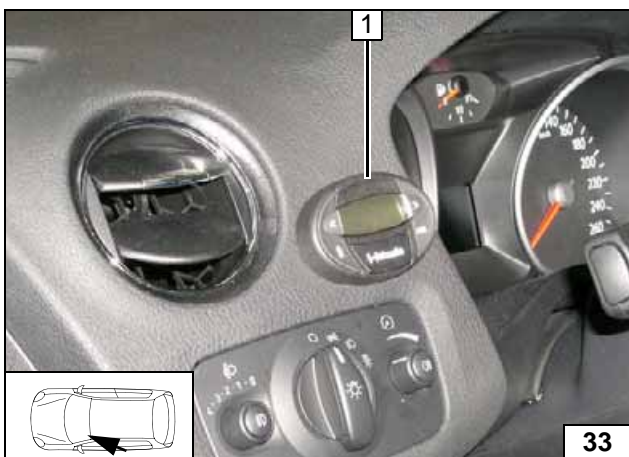

**Mondeo**

1 Digital timer

**Installing digital timer**

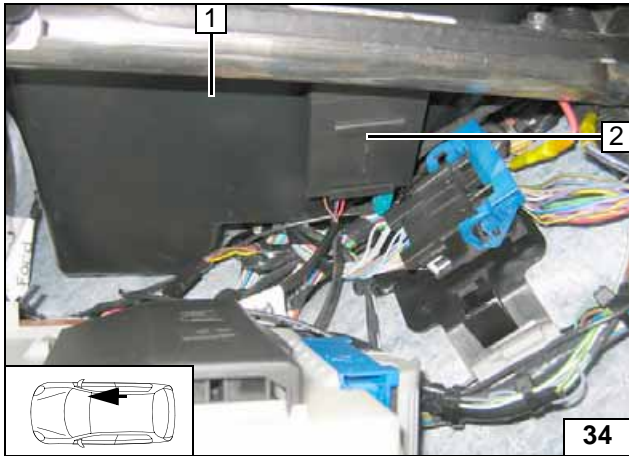

**Remote Option (Telestart)**

**S-MAX / Galaxy**

Fasten receiver 2 with adhesive tape.

- 1 Underside of glove compartment



**Mounting receiver**

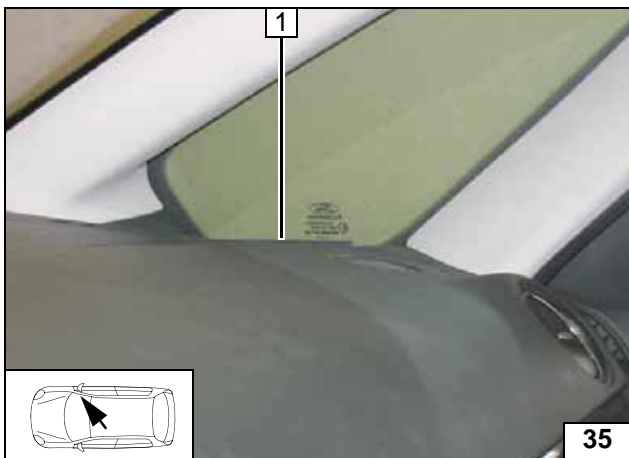

- 1 Antenna



**Mounting antenna**

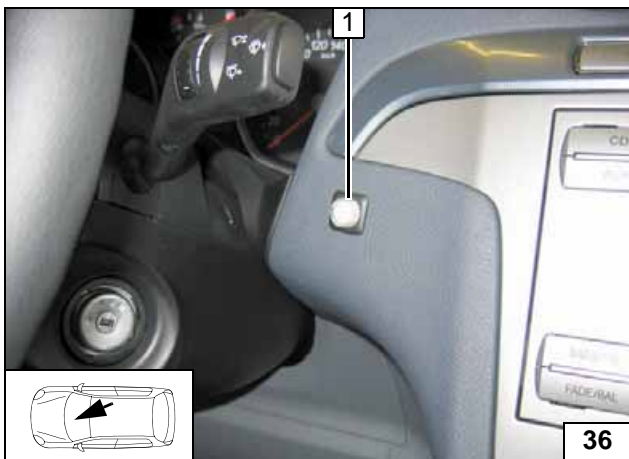
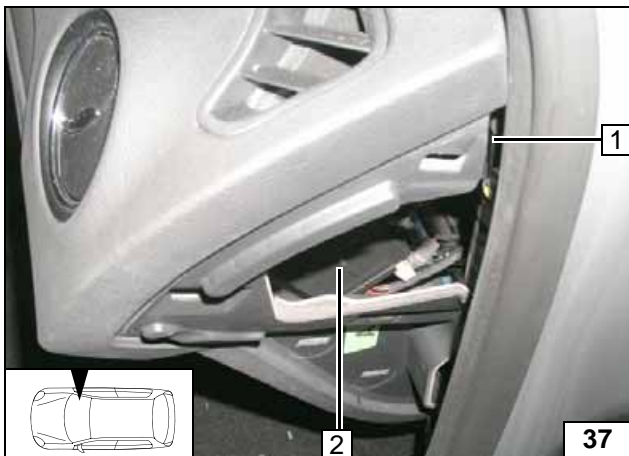

Image shows vehicle up to MY 2009!

- 1 Push button



**Mounting push button**



**Mondeo**

Fasten receiver 2 with adhesive tape.

- 1 Temperature sensor T100 HTM



**Mounting receiver**

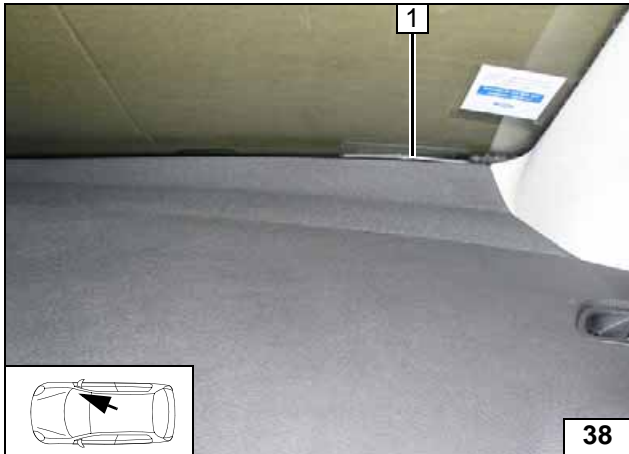

**Note:**

For vehicles with windscreen heating, do not glue the antenna in the area of the window heating.

- 1 Antenna



**Mounting antenna**

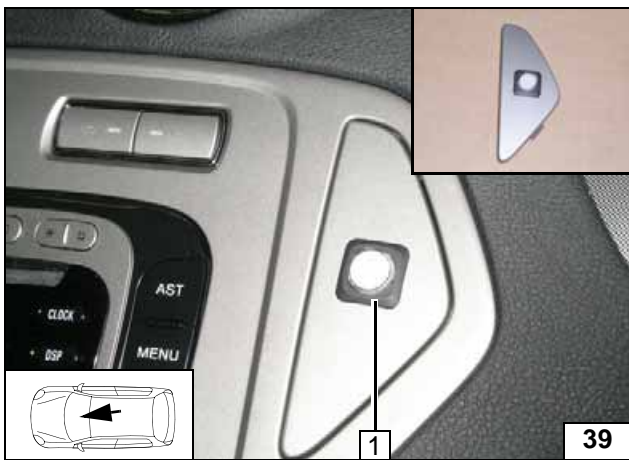

- 1 Push button



**Mounting push button**

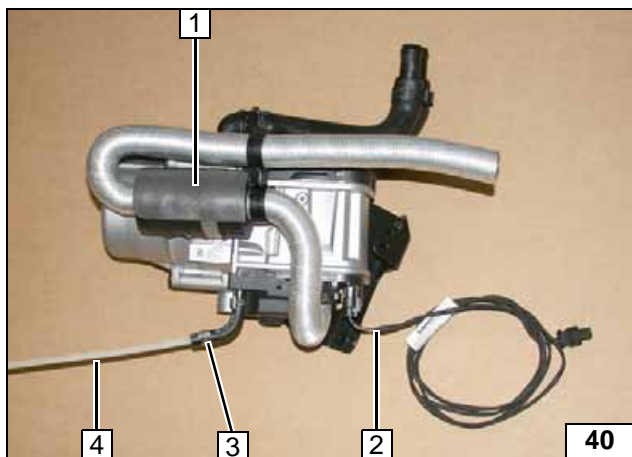

### Preparing Heater

Glue insulation protection strips 1 onto the combustion air silencer.

- 2 Install wiring harness of circulating pump
- 3 10 mm dia. clamp
- 4 Fuel line



**Preparing heater installation**

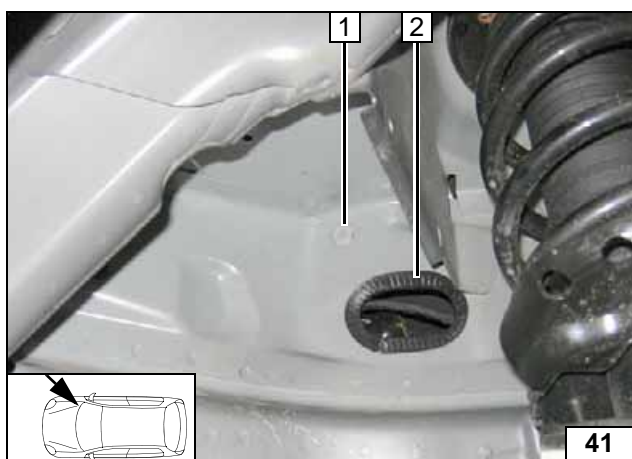

Insert cable grommet 1 and edge protection section 2.



**Preparing installation location**

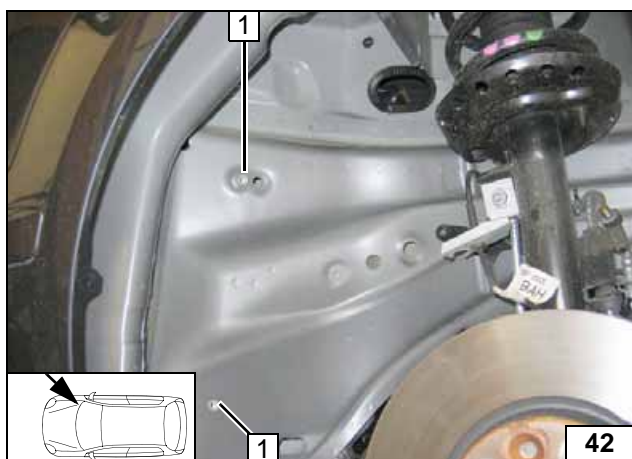

- 1 Rivet nut, existing hole [2x each]

**Installing rivet nuts**



Remove water drain 1 from wheel arch.



**Preparing installation location**

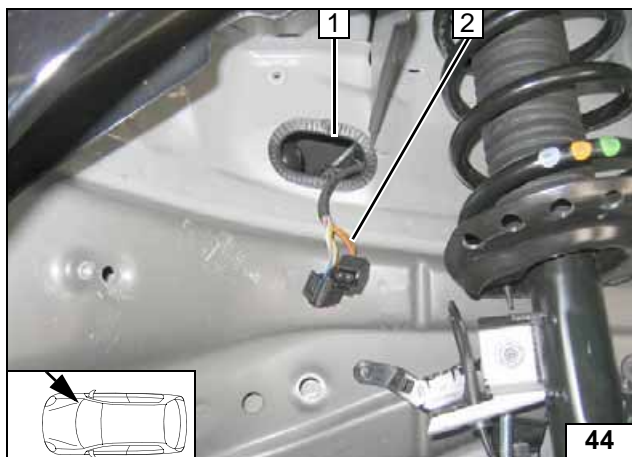

- 1 Pass through
- 2 Wiring harness of heater

Installing wiring harness of heater

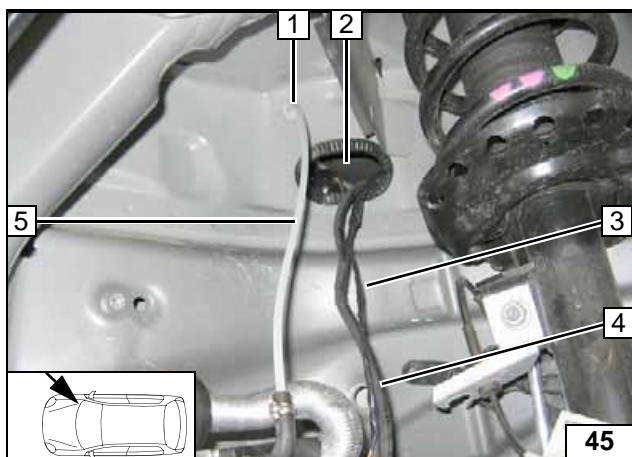

### Installing Heater

Route fuel line 5 through grommet 1 into engine compartment. Route wiring harness of circulating pump 3 through pass through 2 into engine compartment. Mount wiring harness of heater 4 on heater.



Mounting heater

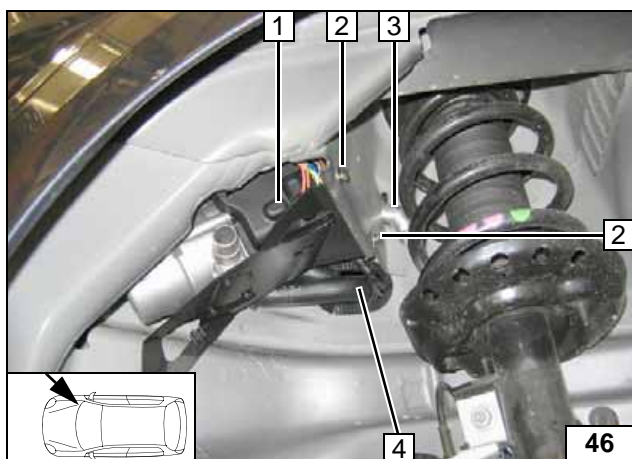

Loosely mount heater 1 as shown. Mind the combustion air silencer when inserting the installation.

- 2 M6x20 bolt [2x], spring lockwasher [2x], large diameter washer [2x]
- 3 Combustion air pipe
- 4 Water hoses [2x]



Loosely mounting heater

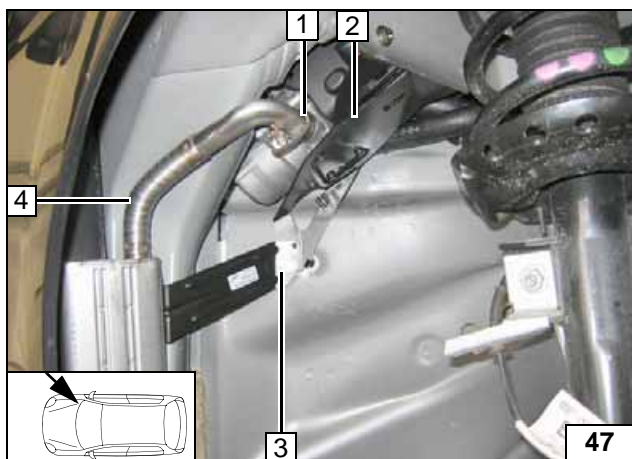

### Installing Exhaust System

Install exhaust system 4 on heater 2 as shown. Ensure sufficient distance from neighbouring components.

- 1 Hose clamp
- 3 M6x20 bolt, spring lockwasher, washer



Mounting exhaust system

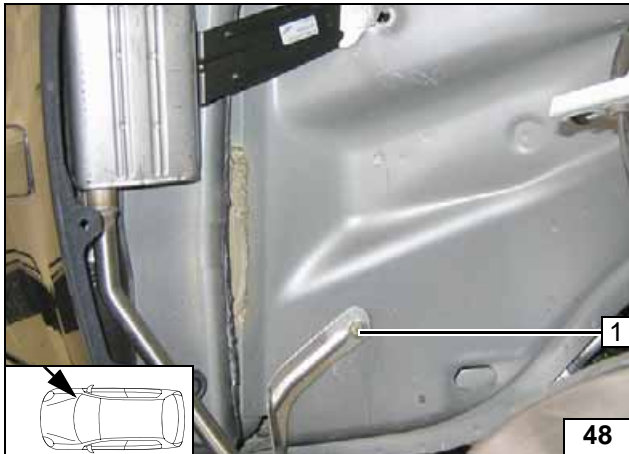

1 M6x20 bolt, spring lockwasher, washer

**Mounting  
exhaust  
system**

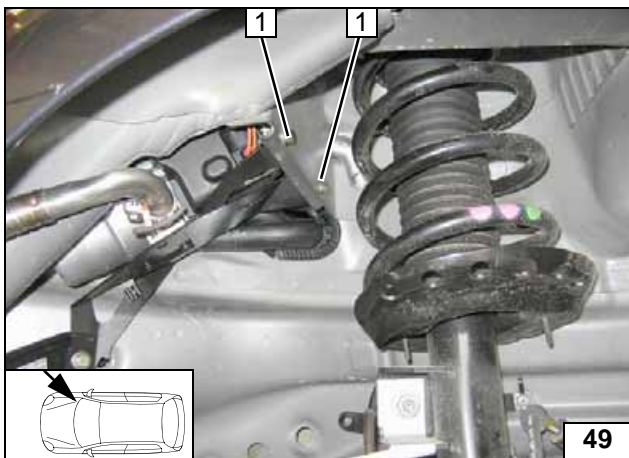

Tighten M6x20 bolt 1 [2x].



**Mounting  
heater**

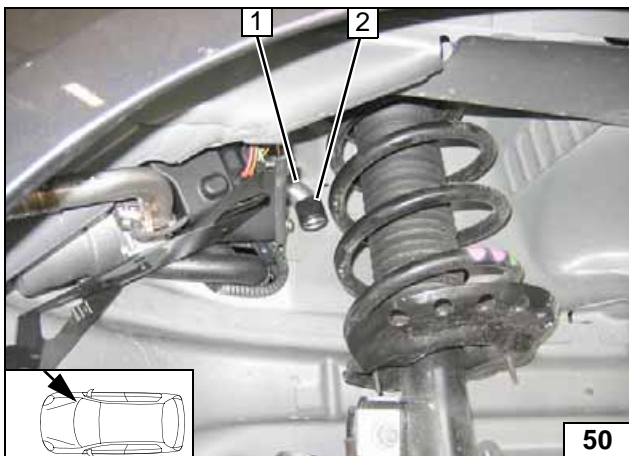

Screw protective cap 2 onto combustion air pipe 1.



**Mounting  
protective  
cap**

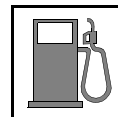

**Fuel**

**CAUTION!**

Open the vehicle's fuel tank cap, ventilate the tank and then re-close the tank lock.

Any fuel running off should be collected in an appropriate container.

Install fuel line and metering pump wiring harness so that they are protected against stone impact. Unless specified otherwise, always fasten using cable ties.

Mount the fuel line and wiring harness with rub protection on sharp edges.

**WARNING!**

The fuel line and wiring harness are routed to the metering pump as shown in the wiring harness routing diagram.

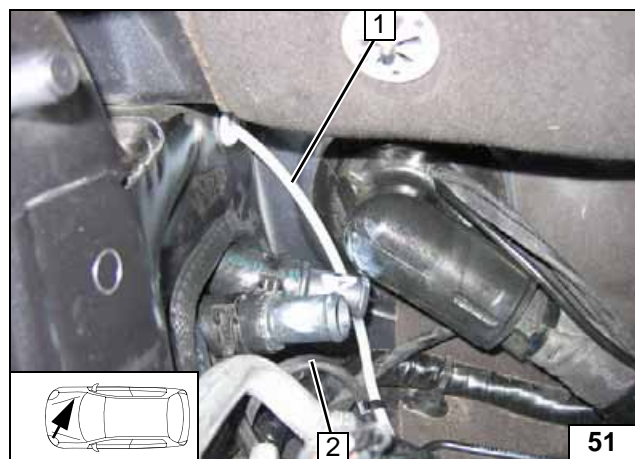

Route fuel line 1 and metering pump wiring harness 2 to underbody and secure on original vehicle lines with cable ties.

Routing lines

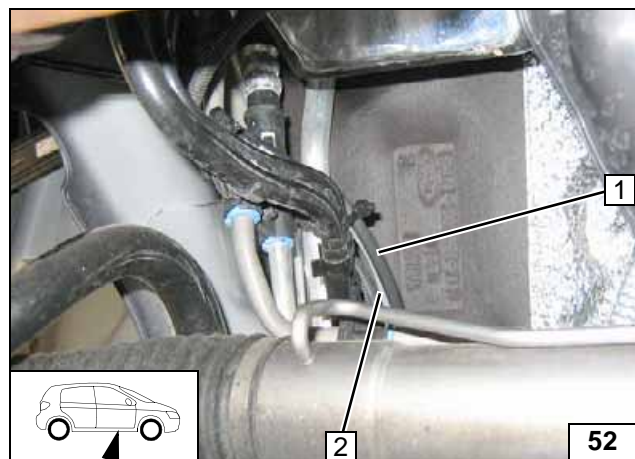

Route fuel line 2 and metering pump wiring harness 1 to underbody and secure on original vehicle lines with cable ties.

Routing lines

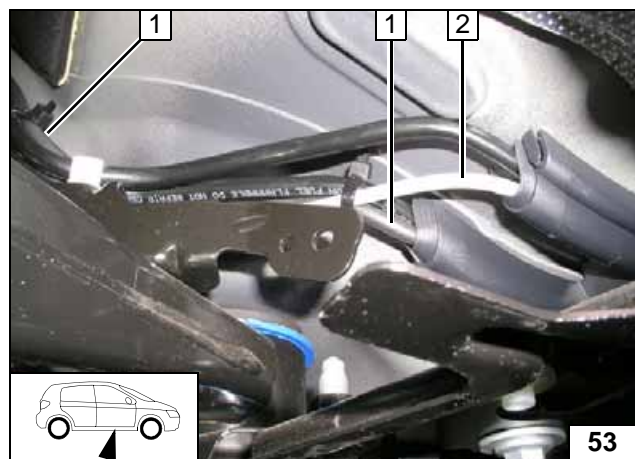

Secure lines with cable ties.

- 1 Metering pump wiring harness
- 2 Fuel line

Routing lines



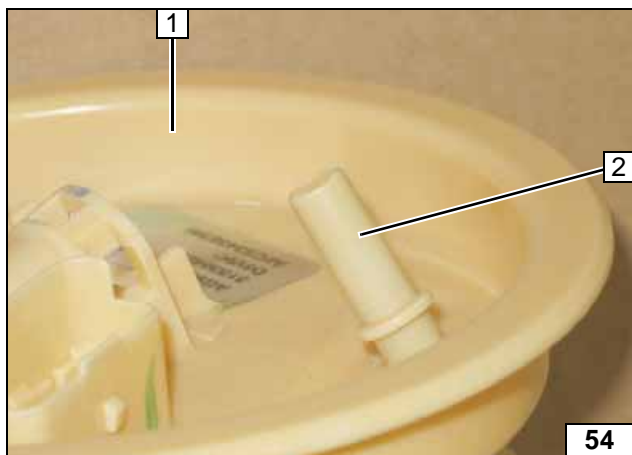

Figures concerning fuel extraction show Mondeo vehicle from model year 2011 onwards. Working steps apply to all vehicles!

Remove fuel tank according to manufacturer's instructions. Remove and dismantle fuel-tank sending unit **1** according to manufacturer's instructions. Cut off the tip of connection piece **2** and countersink gently.



**Fuel extraction**

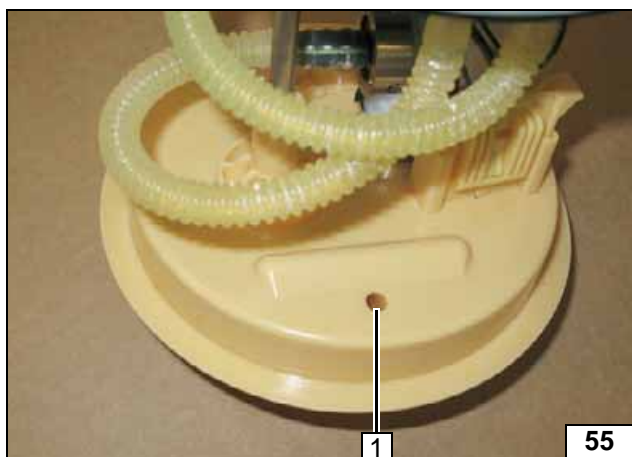

**1** Drill out 5.1 mm dia. hole



**Fuel extraction**

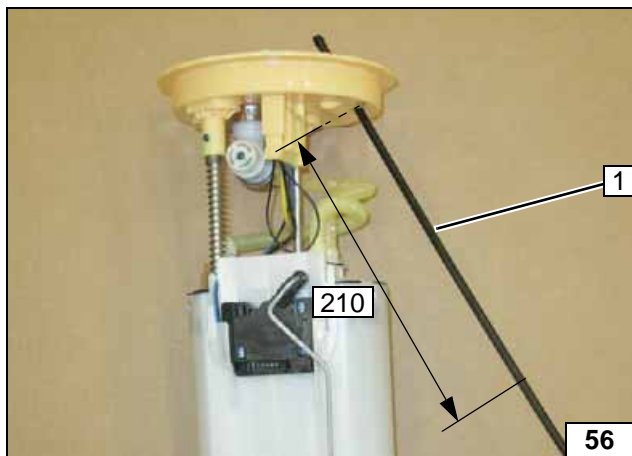

Insert standpipe **1** into the connection piece and cut it to length obliquely at the end (measured from standpipe passage).



**Cutting fuel standpipe to length**

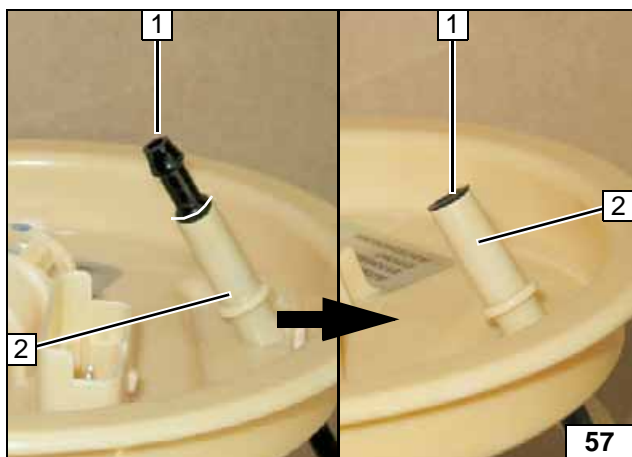

Cut standpipe **1** to length at centre in the bulge as shown.

**2** Connection pieces



**Cutting fuel standpipe to length**

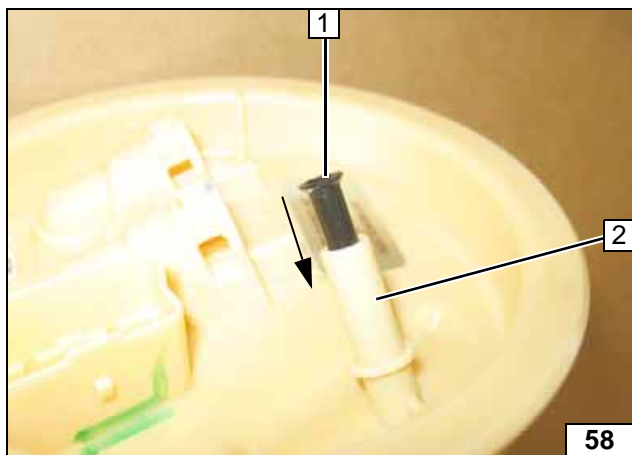
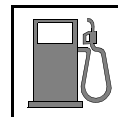

Glue standpipe 1 into the connection piece with suitable contact adhesive.



- 2 Connection pieces

Pasting/gluing fuel stand-pipe

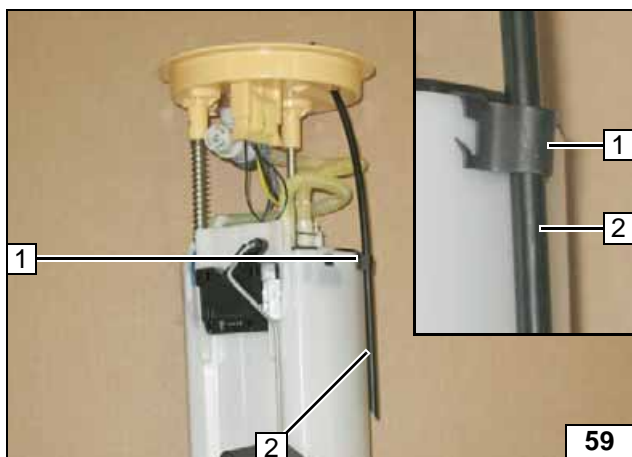

- 1 Installing retaining clamp
- 2 Standpipe

Fixing of fuel stand-pipe

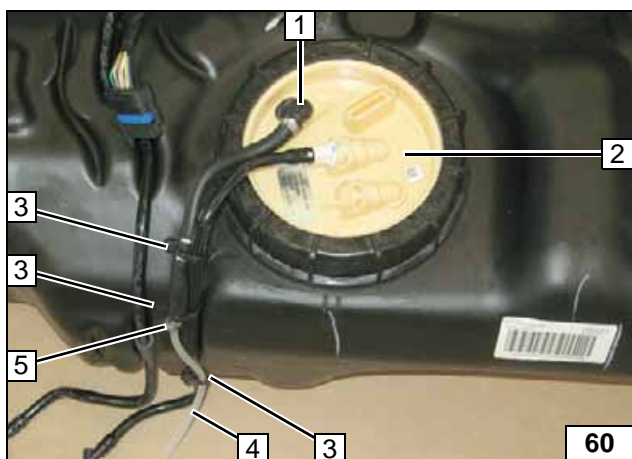

Install fuel-tank sending unit 2 in fuel tank according to manufacturer's instructions. Only mount hose coupling 1 on connection piece after the glue has hardened. Mount fuel tank according to manufacturer's instructions.



- 3 Cable tie [3x]
- 4 500 mm fuel line
- 5 10 mm dia. clamp

Fuel extraction

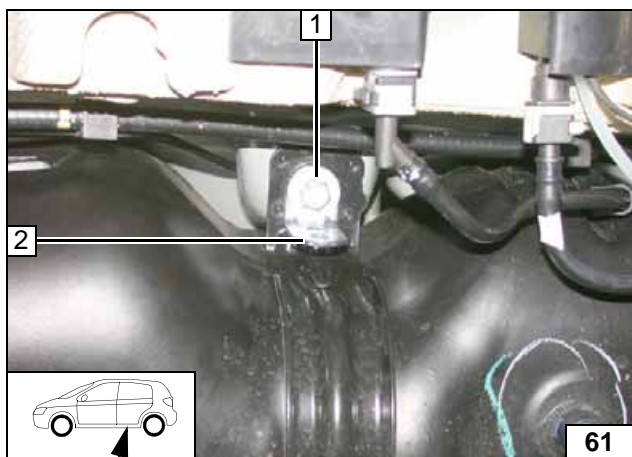

All vehicles

- 1 M6x20 bolt, large diameter washer, flanged nut, existing hole
- 2 Angle bracket

Mounting angle bracket

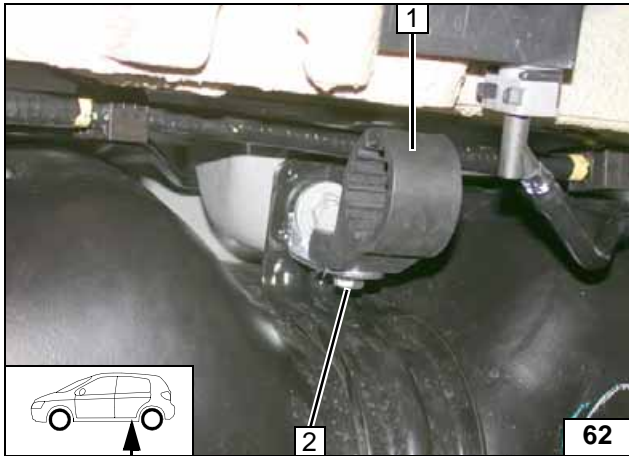

- 1 Mounting of metering pump
- 2 M6x25 bolt, support bracket, large diameter washer, flanged nut

**Installing metering pump mounting**

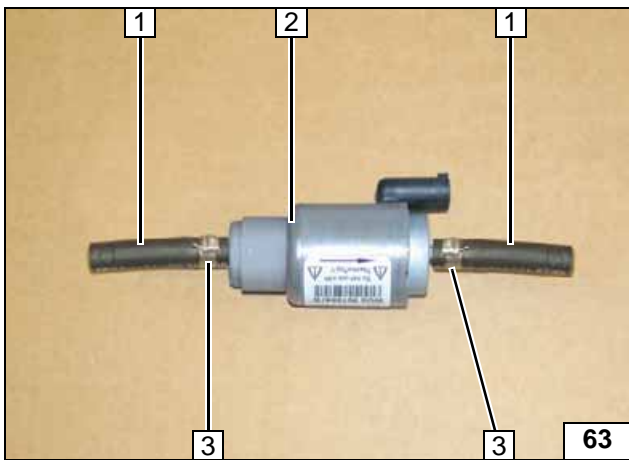

- 1 Hose section [2x]
- 2 Metering pump
- 3 10 mm dia. clamp [2x]

**Premounting metering pump**

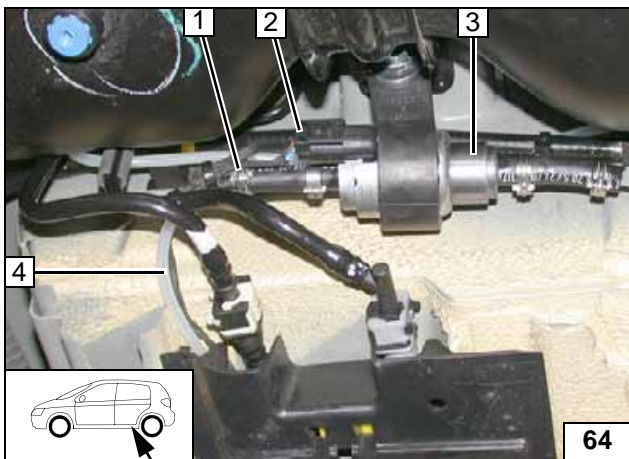

- 1 10 mm dia. clamp
- 2 Wiring harness of metering pump, connector mounted
- 3 Metering pump
- 4 Fuel line from heater



**Connecting metering pump**

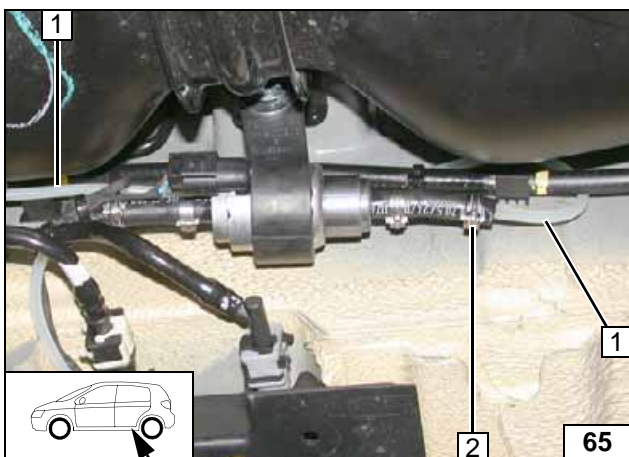

- 1 Fuel line from fuel standpipe
- 2 10 mm dia. clamp [2x]



**Connecting metering pump**

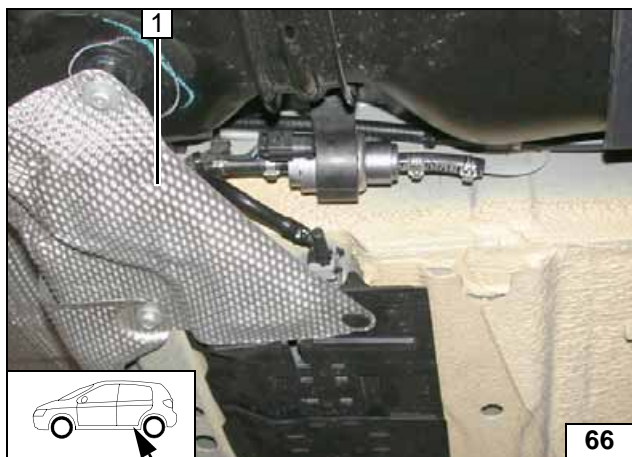
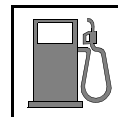

Check the position of the components; adjust if necessary. Check that they have freedom of movement.

1 Cover



Installing cover





## Coolant Circuit

### WARNING!

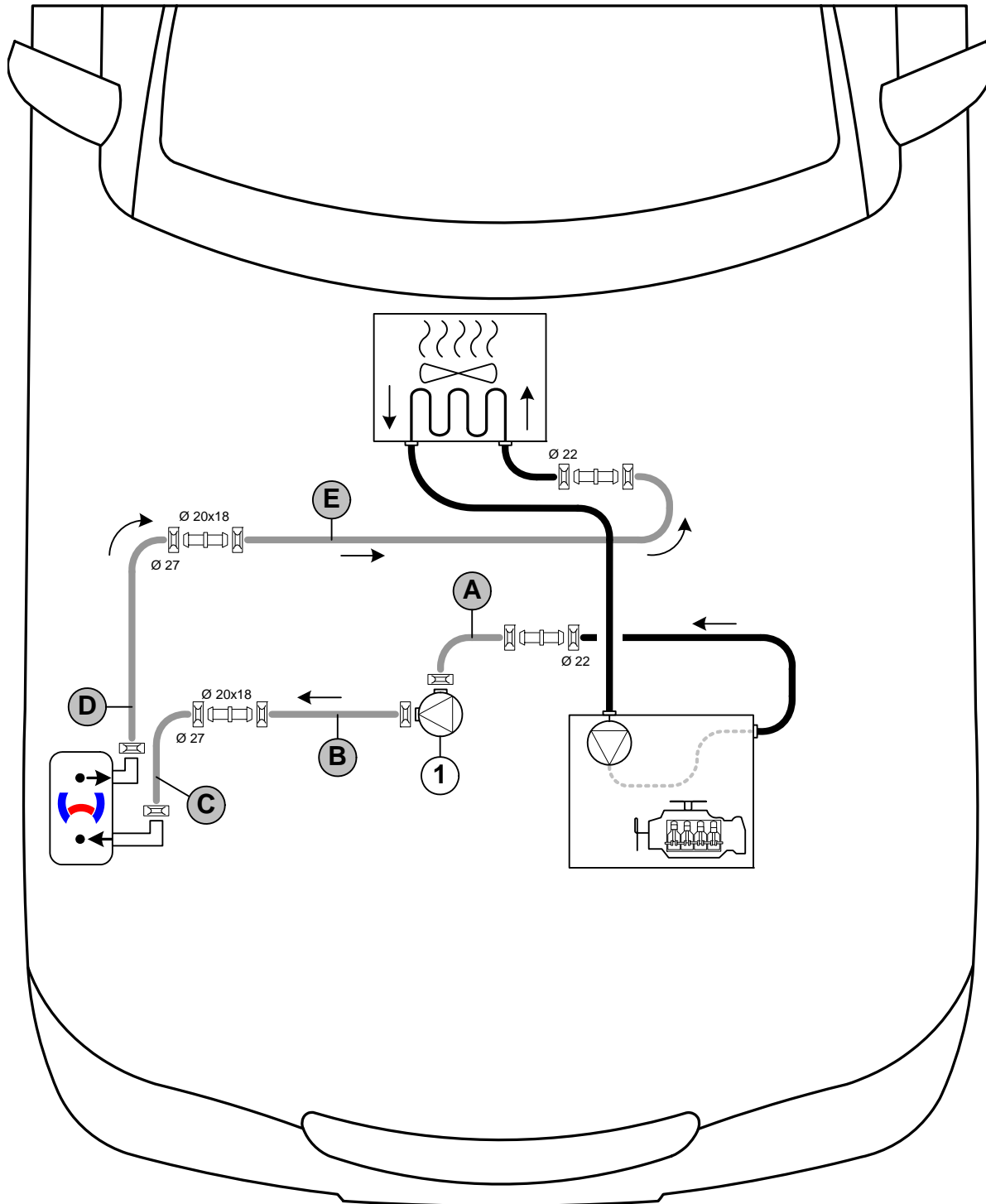
Any coolant running off should be collected in an appropriate container. Route hoses kink-free. Unless specified otherwise, always fasten using cable ties. Position clamps so that other hoses cannot be damaged. When installing the hoses, the heater must be filled with coolant. The connection should be "inline" based on the following diagram:



Hose routing diagram

All spring clips without a specific designation  = 25 mm dia.  
 1= Circulating pump  
 All non-designated connecting pipes  = 15x18mm dia.!



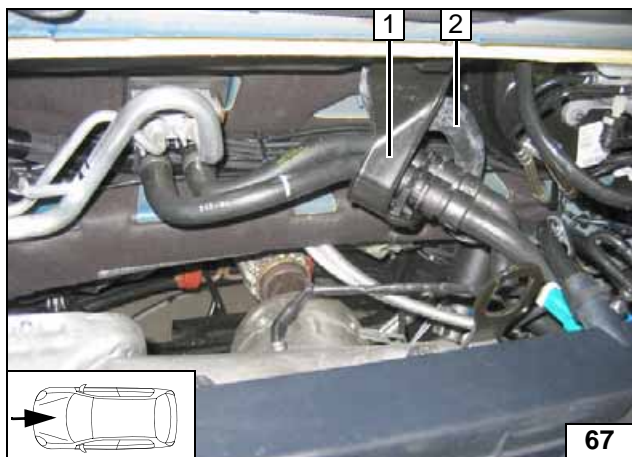

Remove hose bracket 1; will be reused (on S-MAX and Galaxy) or loosen it (on Mondeo). Unclip water drain hose 2; will be reused.



**Preliminary work**

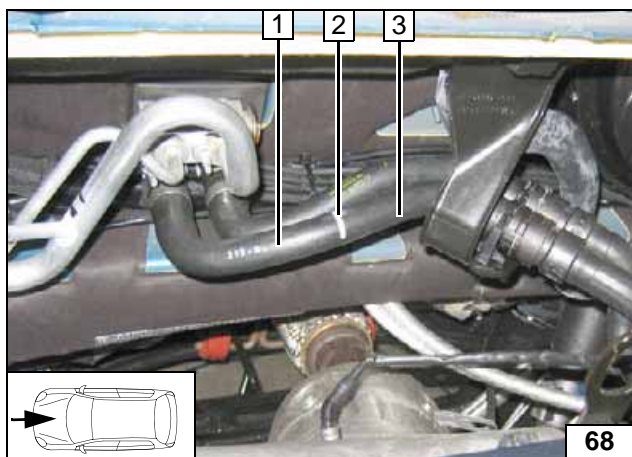

- 1 Hose section of heat exchanger inlet
- 2 Cutting point
- 3 Engine outlet hose section

**Cutting point**

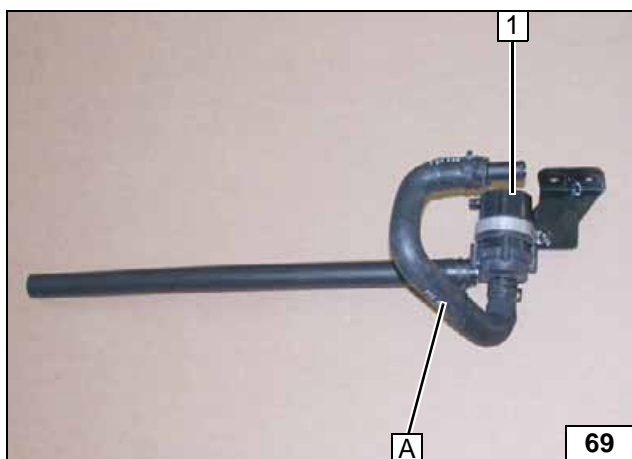

Hose A = 18mm dia. moulded hose

- 1 Premounted circulating pump assembly



**Mounting Hose A**

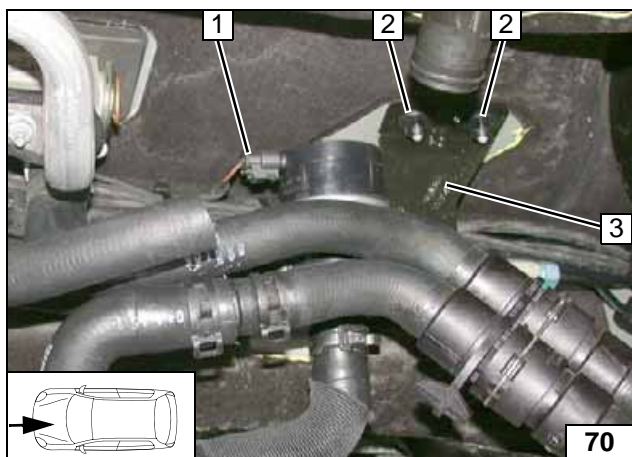

Mount wiring harness of circulating pump 1.

- 2 Original vehicle stud bolt, plastic nut [2x each]
- 3 Bracket of circulating pump



**Mounting circulating pump assembly**

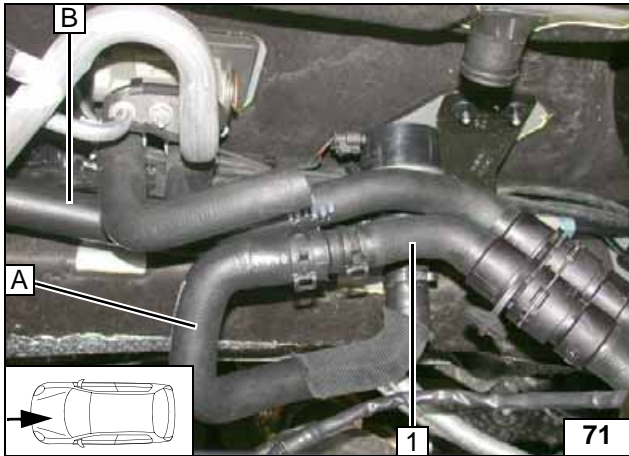

1 Engine outlet hose section

Connect-  
ing engine  
outlet

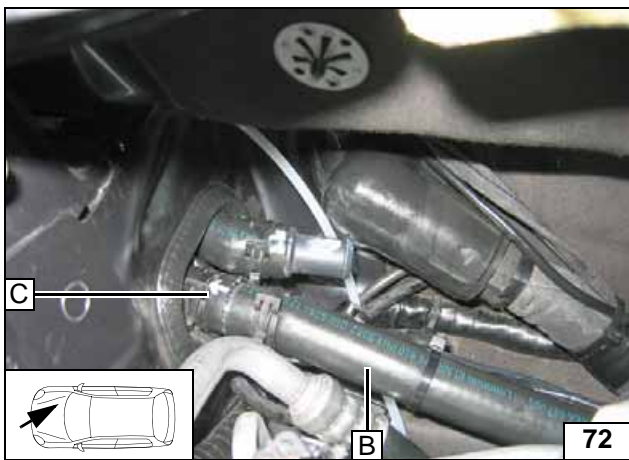

Connec-  
tion on  
heater inlet

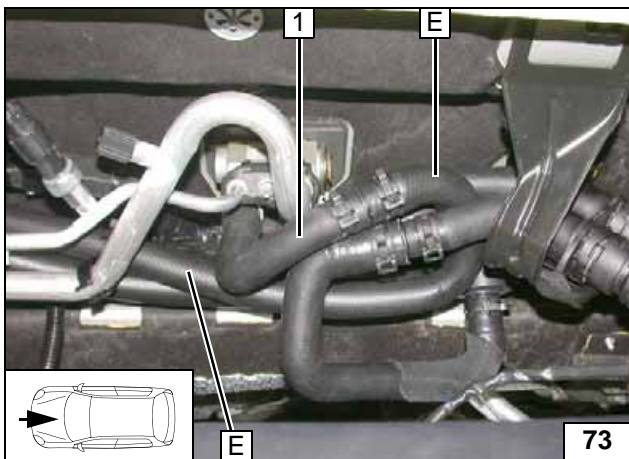

Hose E = 180°, 18mm dia. moulded hose

1 Hose section of heat exchanger inlet



Connec-  
tion heat  
exchanger  
inlet

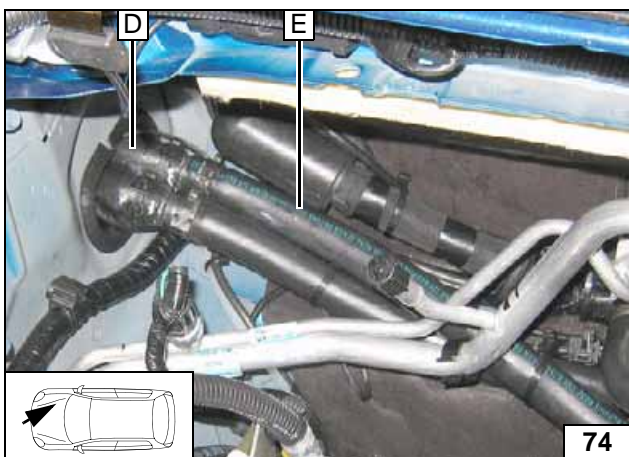

Connec-  
tion on  
heater out-  
let

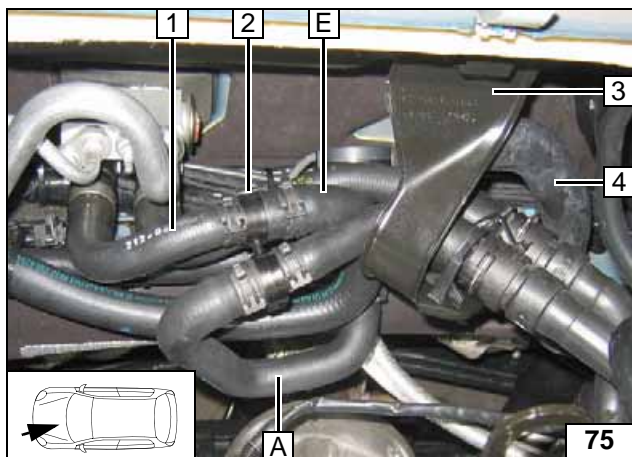

Ensure sufficient distance from neighbouring components.



- 1 Hose section of heat exchanger inlet
- 2 Hose bracket
- 3 Hose bracket
- 4 Water drain hose

**Installing  
hose  
bracket  
and water  
drain**





## Final Work

### WARNING!

Mount removed parts in reverse order. Check all hoses, clamps and all electrical connections for firm seating. Insulate and tie back all loose wires.

Only use manufacturer-approved coolant. Spray heater components with anti-corrosion wax (Tectyl 100K, Order No. 111329).



- Connect the battery.
- Fill and bleed the coolant circuit according to the vehicle manufacturer's specifications.
- Adjust digital timer, teach Telestart transmitter.
- Make settings on A/C control panel according to the "Operating Instructions for End Customer".
- Place the "Switch off parking heater before refuelling" signboard in the area of the filler neck.
- See installation instructions for initial startup and function check.
- Decode the radio according to the manufacturer's instructions

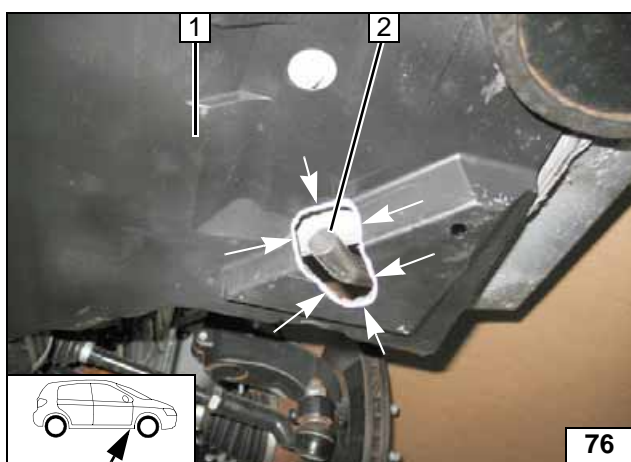

Cut out at marking in lower trim **1** (if installed) in area of exhaust outlet **2**.



**Cutting out  
underride  
protection**

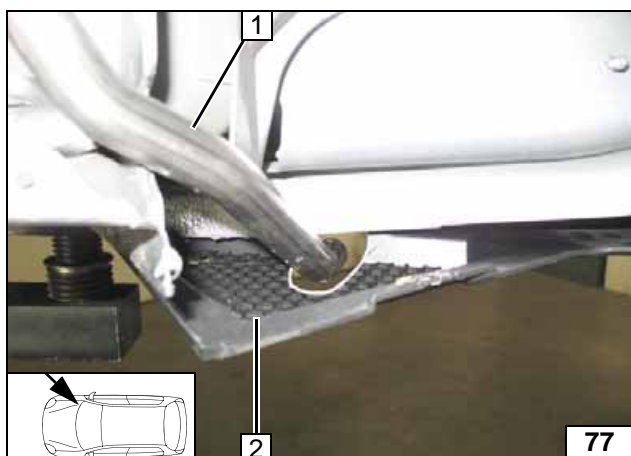

Ensure sufficient distance from neighbouring components.

- 1 Exhaust end section
- 2 Lower trim



**Exhaust  
end section**

Webasto Thermo & Comfort SE  
Postfach 1410  
82199 Gilching  
Germany  
Internet: [www.webasto.com](http://www.webasto.com)  
Technical Extranet:  
<http://dealers.webasto.com>

## Operating Instructions for End Customer

Please remove this page in case of automatic air-conditioning and add it to the vehicle operating instructions.

### Note:

We recommend matching the heating time to the driving time.

Heating time = driving time

### Example:

For a driving time of approx. 20 min. (in one direction), we recommend not exceeding a switch-on time of 20 min.

Passenger compartment monitoring, if installed, must be deactivated in addition to the vehicle settings for the heating operation.

Instructions for deactivation can be taken from the operating instructions manual of the vehicle.

Before parking the vehicle, make the following settings:

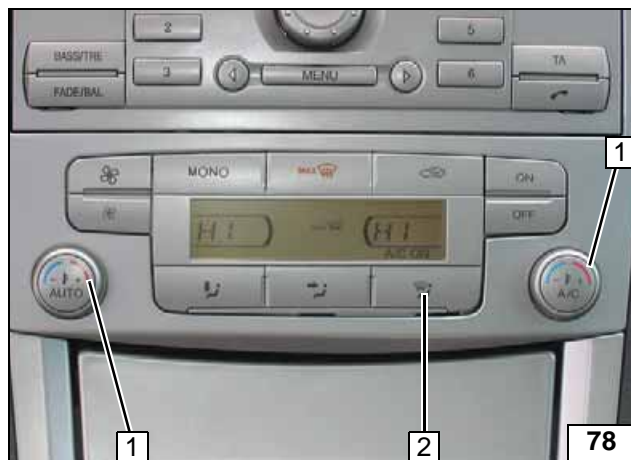

Fan speed is preset in parking heating mode!

- 1 Set temperature to "HI" on both sides
- 2 Air outlet to windscreen



Fan speed is preset in parking heating mode!

- 1 Set temperature to "HI" on both sides
- 2 Air outlet to windscreen

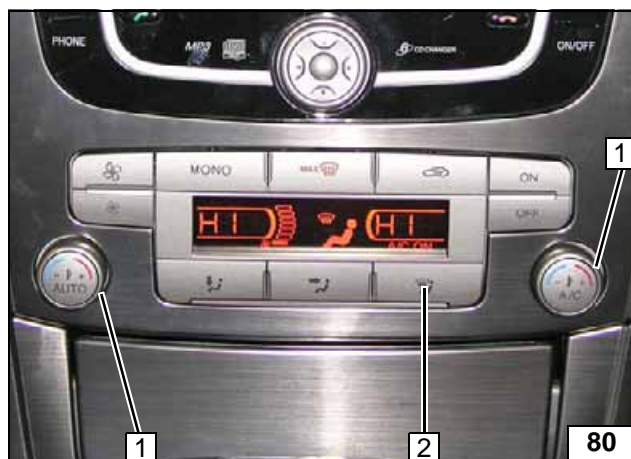

Fan speed is preset in parking heating mode!

- 1 Set temperature to "HI" on both sides
- 2 Air outlet to windscreen



Up to model year 2009 without touch screen



Up to model year 2009 with touch screen



Starting with 2010



Fan speed is preset in parking heating mode!



- 1 Set temperature to "HI" on both sides
- 2 Air outlet to windscreen

Starting with model year 2011 without touch screen



Fan speed is preset in parking heating mode!



- 1 Air outlet to windscreen
- 2 Set temperature to "HI" on both sides

Starting with model year 2011 with touch screen

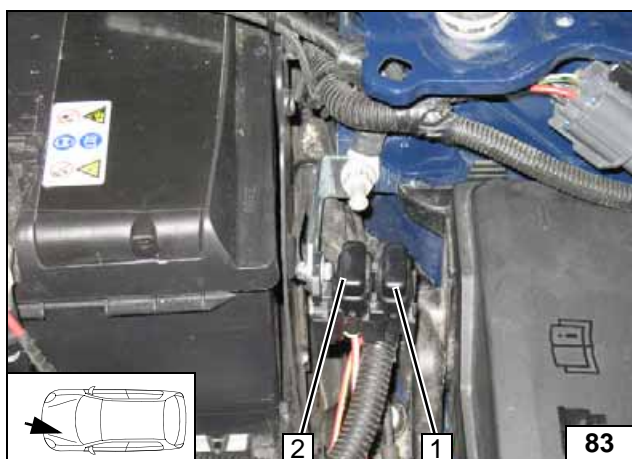

All vehicles

- 1 20A fuse F1 of heater
- 2 30A main fuse F2 of passenger compartment

Fuses of engine compartment

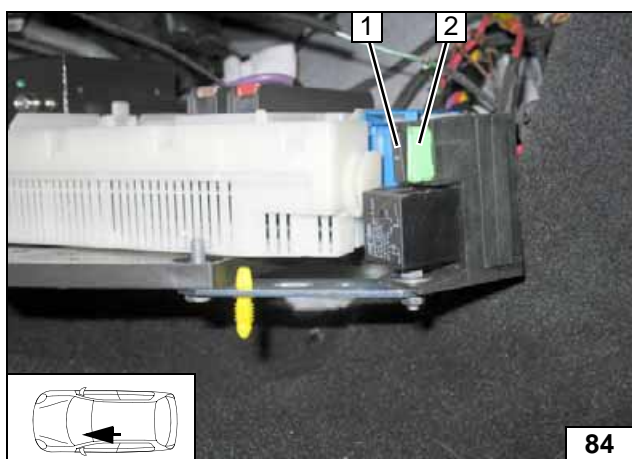

- 1 1A fuse F3 of heater control
- 2 30A fan fuse F4

Fuses of passenger compartment