

Water Heater



Thermo Top E Parking Heater

e1
00 0003

Thermo Top C Parking Heater

e1
00 0002

Installation documentation

Skoda Octavia

1.6 and 2.0 TDI Common Rail
from Model Year 2009
Left-hand drive vehicle
Manual transmission



WARNING!

Hazard warning:

Incorrect installation or repair of Webasto heating systems may cause a fire or result in the emission of carbon monoxide, which can be fatal. Serious or fatal injuries can be caused as a result.



Specialist company training, technical documentation, specialised tools and equipment are required to install and repair Webasto heating and cooling systems. Only original Webasto parts must be used. For this, also see the catalog of air and water heater accessories from Webasto.

NEVER attempt to install or repair Webasto heating or cooling systems if you have not successfully completed the company training and thereby acquired the required technical skills, or if you do not have access to the required technical documentation, tools and equipment needed to carry out correct installation and repairs.

ALWAYS follow all Webasto installation and repair instructions and observe all warnings.

The initial startup is to be executed with the Webasto Thermo Test Diagnosis.

Webasto does not accept any liability for defects and damage that are attributable to installation by untrained staff.

Table of Contents

Validity	2	Digital timer	12
Heater / Installation Kit	3	Remote option Telestart	12
Foreword	3	Premounting heater	13
General Instructions	3	Preparing exhaust	14
Special Tools	3	Preparing coolant circuit	15
Explanatory Notes on Document	4	Installing heater	19
Preliminary Work	5	Fuel	21
Heater installation location	5	1.6 TDI coolant circuit	24
Electrical system	6	2.0 TDI coolant circuit	27
Fuse holder and K3 relay	7	Exhaust gas	32
Climatic fan controller	8	Final Work	33
Climatronic fan controller	9	Operating Instructions for End Customer	34

Validity

Manufacturer	Model	Type	EG-BE No./ABE
Skoda	Octavia	1Z	e1 * 2001 / 116 * 0230 * ...

Engine type	Engine model	Output in kW	Displacement in cm ³
CAYC	Diesel	77	1598
CFHC	Diesel	103	1968
CEGA	Diesel	125	1968

Vehicle and engine types, equipment variants and national specifications not listed in these installation instructions have not been tested. However, installation according to this installation documentation may be possible.

The installation location of a digital timer and summer/winter switch should be confirmed with the end customer before installation.

Heater / Installation Kit

Quantity	Description	Order No.:
1	Retail accessories Thermo Top E / C / P	See price list
1	Installation Kit for Skoda 1.6 and 2.0 TDI Common Rail manual transmission	1316417A
1	Heater control	See price list

Also required with Climatronic

Quantity	Description	Order No.:
1	IPCU Kit for Climatronic	9013645A

Heater recommended for the respective vehicle class:

Vehicle	Heater
Compact car	Thermo Top E
Mid-size car, estate car	Thermo Top C

The selection of the heater is based on the passenger compartment size of the vehicle and the level of comfort required by the customer!



Foreword

This installation documentation applies to Skoda Octavia 1.6 and 2.0 TDI Common Rail vehicles - for validity, see page 2 - from model year 2009 and later, assuming technical modifications to the vehicle do not affect installation, any liability claims excluded. Depending on the vehicle version and equipment, modifications may be necessary during installation with respect to this installation documentation.

However, the stipulations in this "installation documentation", the "operating instructions" and the "installation instructions" for the *Thermo Top C/E* must always be observed.

The corresponding rules of technology and any information from the vehicle manufacturer should be observed during the installation work.

General Instructions

Installation should be carried out according to the general, standard rules of technology. Unless specified otherwise, fasten hoses, lines and wiring harnesses to original vehicle lines and wiring harnesses using cable ties.

Sharp edges should be fitted with rub protection (split-open plastic hose).

Spray unfinished body areas, e.g. drilled holes, with anti-corrosion wax (Tectyl 100K, Order No. 111329).

Special Tools

- Torque wrench for 2.0 - 10 Nm
- Hose clamping pliers

Explanatory Notes on Document

To provide you with a quick overview of the individual working steps, you will find an identification mark on the outside top right corner of the page in question.

Mechanical system

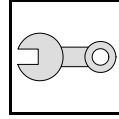

Electrical system

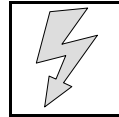

Coolant circuit

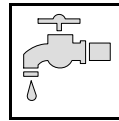

Fuel

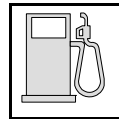

Exhaust gas

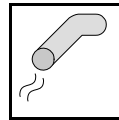

Combustion air

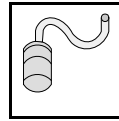

Special features are highlighted using the following symbols:



Specific risk of injury or fatal accidents.



Specific risk of damage to components.



Specific risk of fire or explosion.



Reference to general installation instructions of Webasto components or to the manufacturer's vehicle-specific documents.



Reference to a special technical feature.

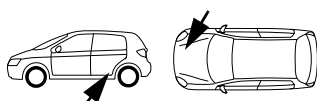

The arrow in the vehicle icon indicates the position on the vehicle and the viewing angle.

All dimensions are in mm!

Tightening torque of hose clamps = 2.0 + 0.5 Nm!

Tightening torque of Ejoy screws, Ejoy studs = 10 Nm!

Preliminary Work

Warning!

- Open the fuel tank cap, ventilate the tank.
- Close the fuel tank cap again.
- Depressurise the cooling system.
- Copy the factory number from the original type label to the duplicate type label.
- Remove years that do not apply from the duplicate label.
- Attach the duplicate label (type label) in the appropriate place.
- Disconnect the battery "earth" or "ground" connection.
- Remove battery with battery carrier coupling
- Remove the engine cover.
- Detach coolant reservoir cap
- Remove the left front wheel
- Remove the front section of the left front wheel well trim
- Remove the left-hand front fog light or, on vehicles without front fog lights, the left-hand cover
- Remove the underride protection
- Remove the right-hand underbody trim
- Remove the rear bench seat
- Open the right-hand tank-fitting service lid
- Remove the footwell trim on the driver's side
- Remove the lower instrument panel trim on the driver's side
- Only vehicles with Climatronic: Remove the footwell trim on the front passenger side

Remove page 34 "Operating Instructions for End Customer" and add to the vehicle operating instructions.

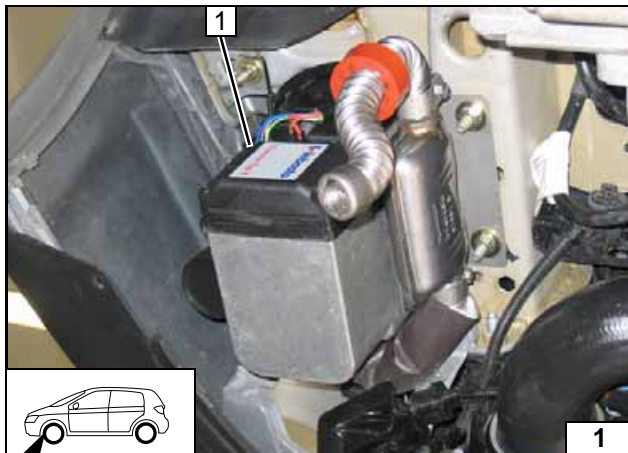

Heater installation location

1 Heater

Installation location



Electrical system

Wiring harness routing

Route excess lengths from wiring harness of heater 1 in cable duct below battery and secure with cable ties.

Wiring harness pass through in engine compartment

- 1 Original vehicle wiring harness pass through
- 2 Wiring harnesses for fan controller and heater control

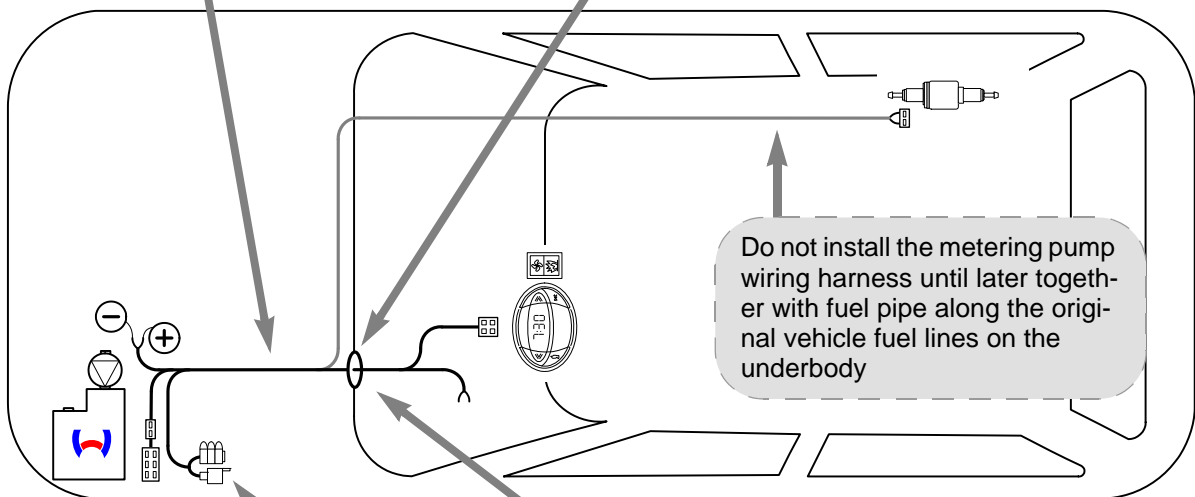
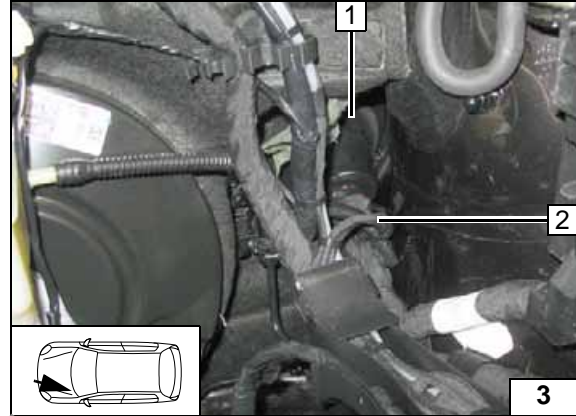
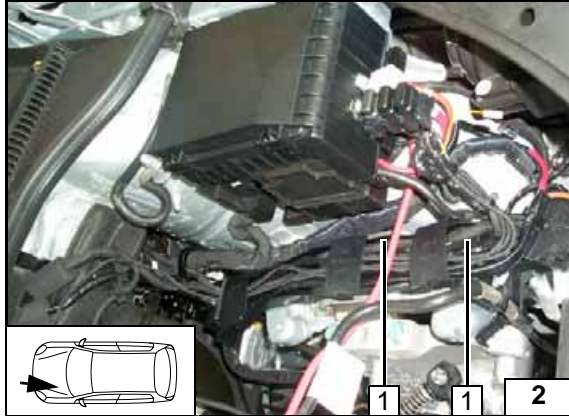

Wiring harness routing diagram

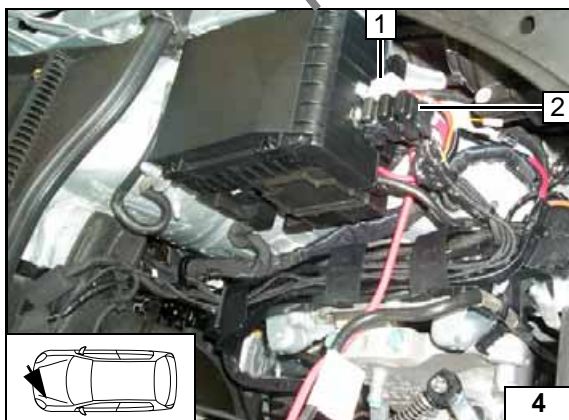

Fuse holder, K3 relay

Description of installation for K3 relay 1 and fuse carrier 2 on Page 7

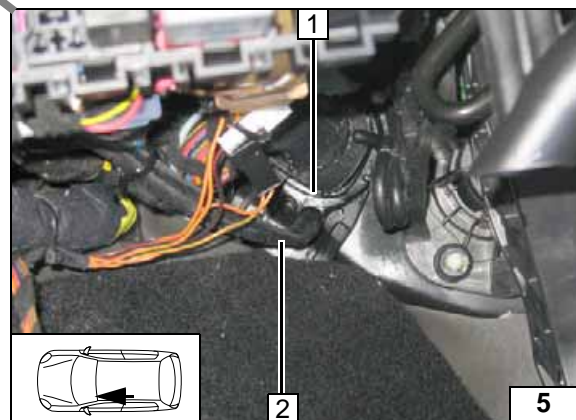

Wiring harness pass through of passenger compartment

- 1 Original vehicle wiring harness pass through
- 2 Wiring harnesses for fan controller and heater control

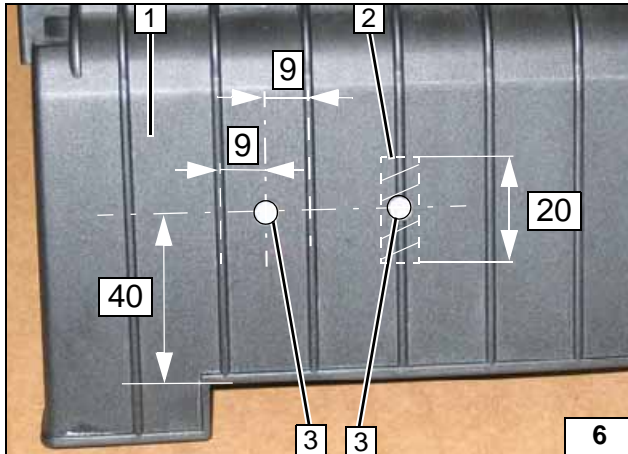

Fuse holder and K3 relay

Countersink holes **3** from behind for M5 countersunk head screws.

- 1** Cover of fuse/relay carrier in engine compartment
- 2** Cut away bar in shaded area
- 3** 5.0 mm dia. hole [2x]



Holes in the cover

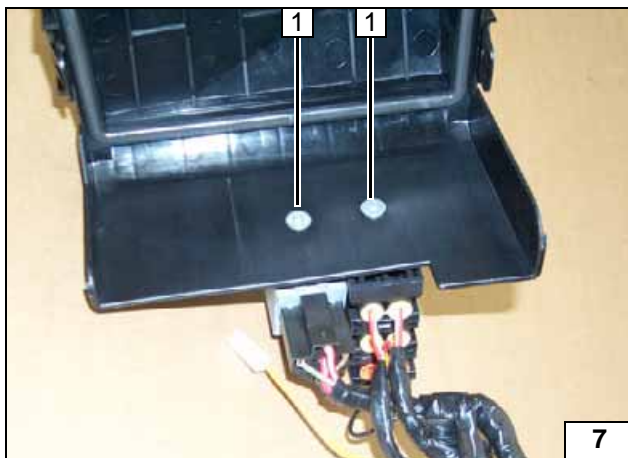

- 1** M5x12 countersunk head screw [2x]

Installing fuse holder and K3 relay

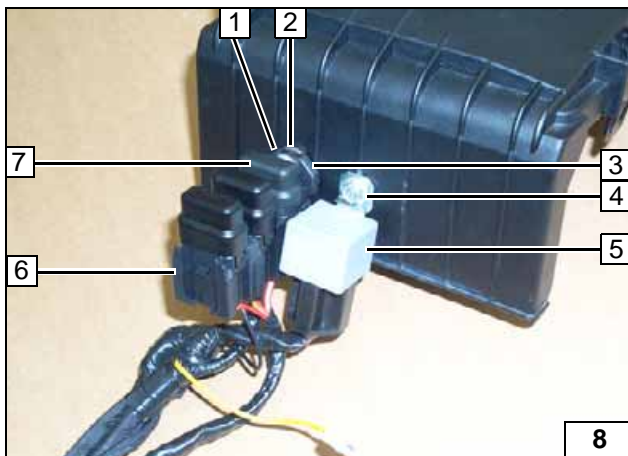

On vehicles with Climatronic, replace 25 A fuse F3 **7** with provided 3A fuse.

- 1** M5 flanged nut
- 2** Large diameter washer (between cover and retaining plate)
- 3** Retaining plate
- 4** M5 flanged nut
- 5** K3 relay
- 6** Fuse holder



Installing fuse holder and K3 relay

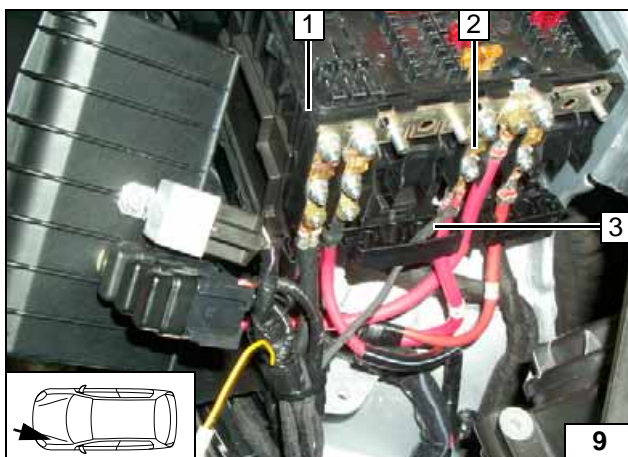

Route brown (br) earth wire to original vehicle earth support point below headlight and connect.

- 1** Fuse/relay carrier
- 2** Original main vehicle fuse
- 3** Red (rt) positive wire



Connecting positive and earth wire



Climatic fan controller

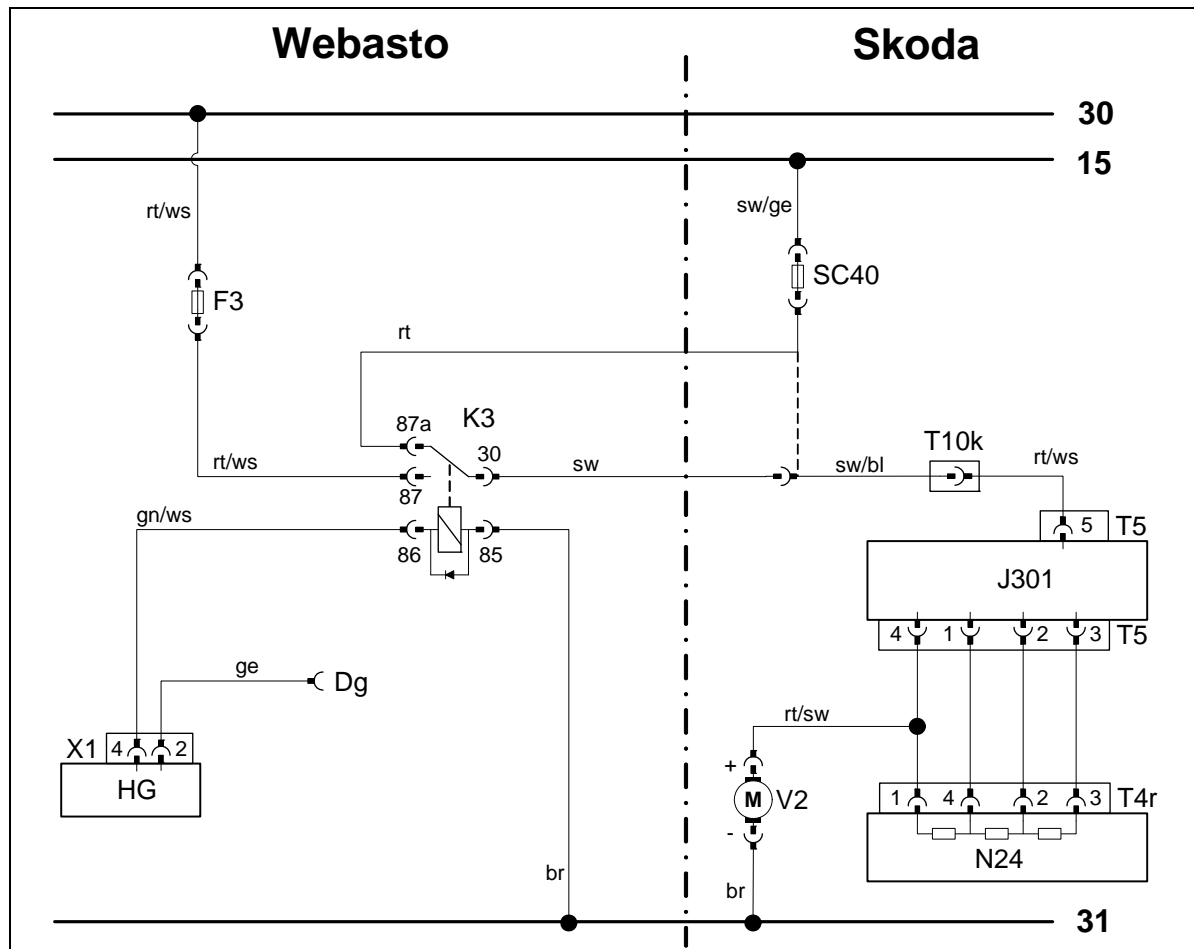

Climatic wiring diagram

Webasto components		Vehicle components		Colours and symbols	
HG	Heater TT-C/E	SC40	40 A fan fuse	rt	red
X1	6-pin heater connector	J301	Control unit of air conditioning	ws	white
F3	25 A fuse F3	N24	Resistor group	sw	black
K3	Fan relay	V2	Fan motor	br	brown
Dg	Diagnosis connection			gn	green
				ge	yellow
				bl	blue
Wiring colours may vary.					

Legend

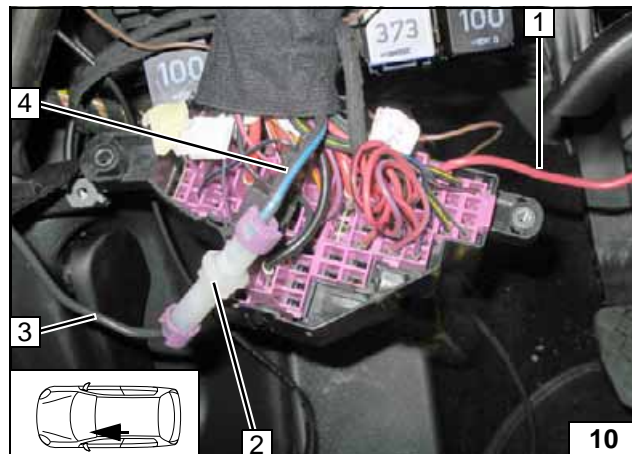

Connection on original vehicle fuse carrier (instrument panel at upper left). Detach black/blue (sw/bl) 4² wire 4 on fuse output SC40. Produce connection as shown in wiring diagram.

- 1 Red (rt) wire of K3/87a engaged in fuse output SC40
- 2 AMP housing
- 3 Black (sw) wire to K3/30



Fan controller



Climatronic fan controller

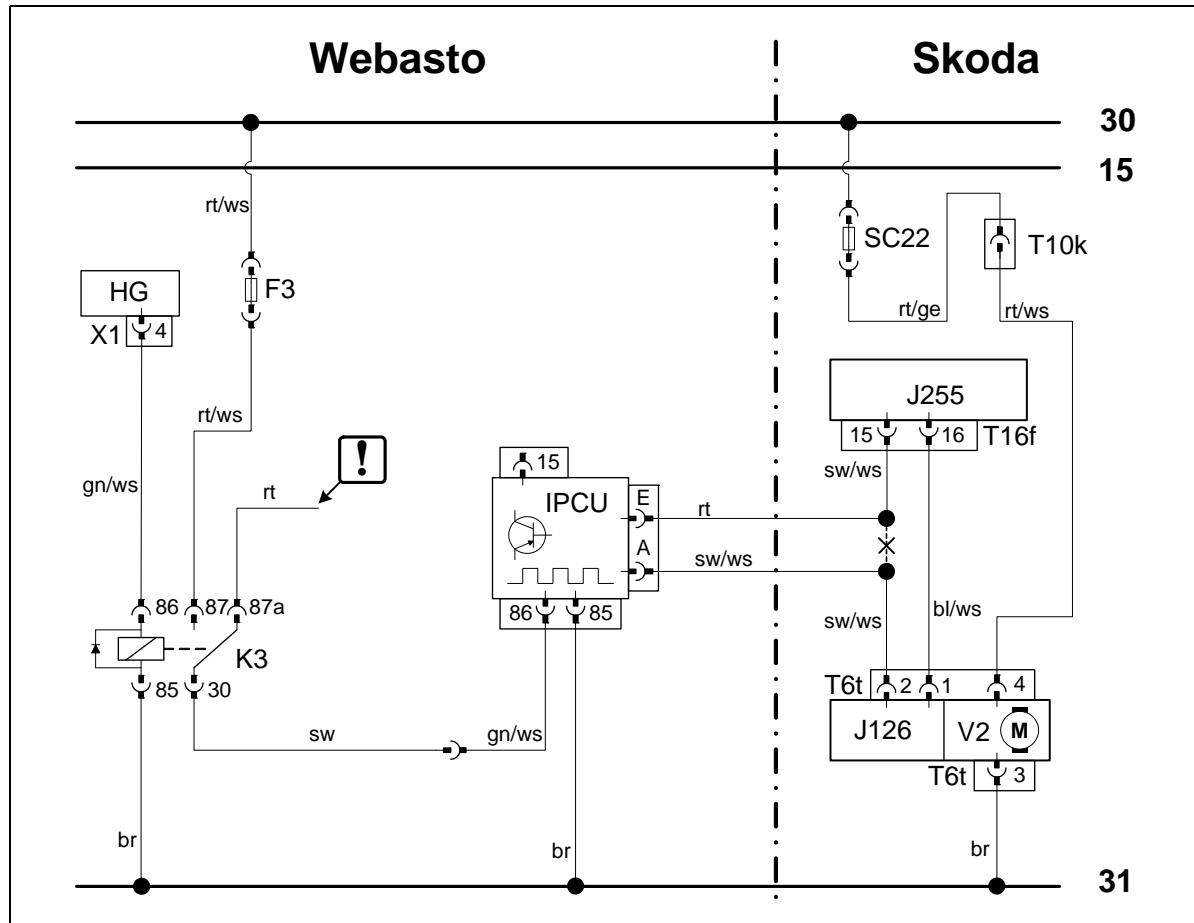

Climatronic wiring diagram

Webasto components		Vehicle components		Colours and symbols	
HG	Heater TT-C/E	SC22	40 A fan-fuse	rt	red
X1	6-pin heater connector	J255	Climatronic control unit	ws	white
F3	Replace 25 A fuse F3 with 5A fuse.	V2	Fan motor	sw	black
K3	Fan relay	J126	Fan control unit	br	brown
IPCU	Pulse width modulator			gn	green
				ge	yellow
				bl	blue
				X	Cutting point
					Insulate wire end and tie back
				Wiring colours may vary.	

Legend

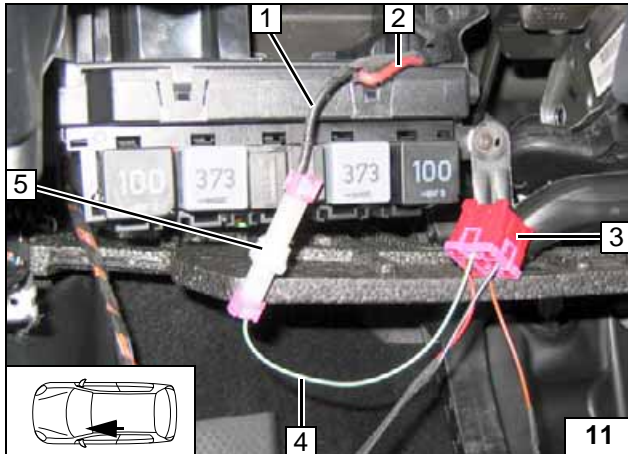
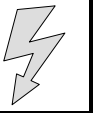

Produce connections as shown in wiring diagram. Insulate red (rt) wire 2 from K3/87a and tie back.

- 1 Black (sw) wire to K3/30
- 3 Socket of IPCU module
- 4 Green/white (gn/ws) wire of IPCU/86
- 5 AMP connector



Preparing IPCU

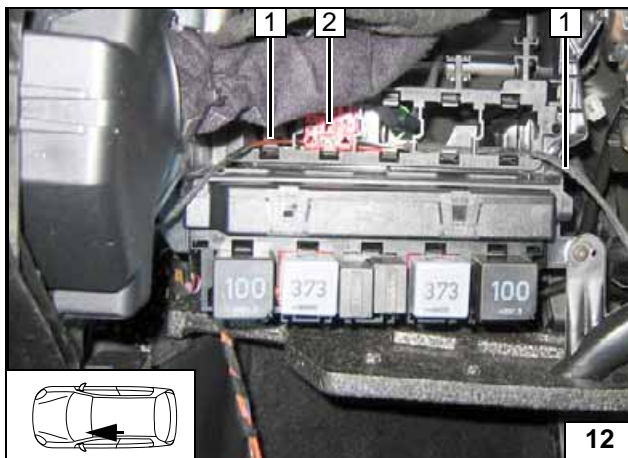

Position of free socket dependent on vehicle equipment.

- 1 Brown (br) wire of IPCU/85
- 2 Socket for IPCU module mounted
- 3 IPCU wiring harness



Preparing IPCU

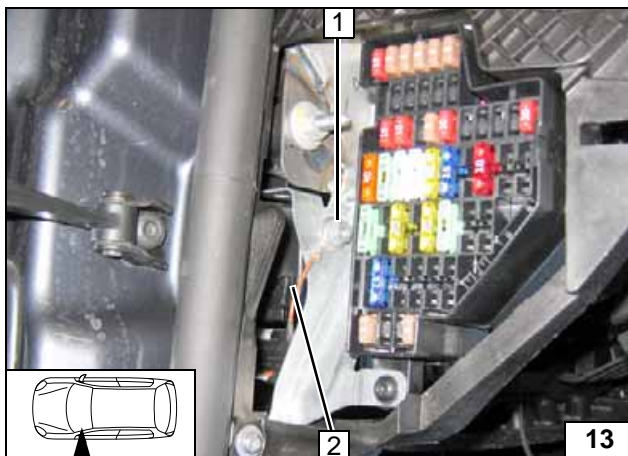

- 1 Original vehicle bolt
- 2 Brown (br) wire of IPCU/85

Earth connection of IPCU

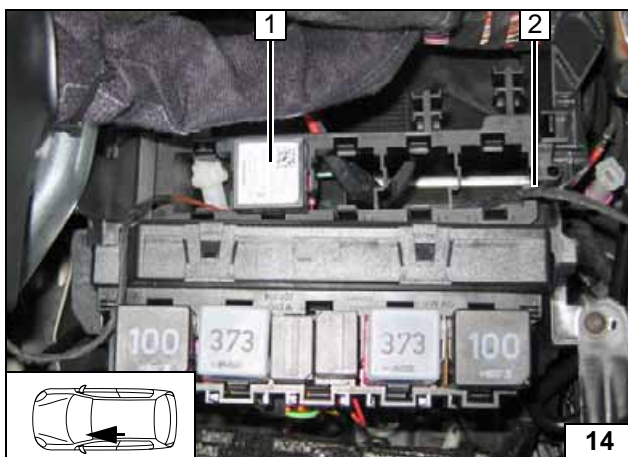

Route wiring harness from IPCU module 2 along air duct to centre console.

- 1 Connect IPCU



Routing wiring harness

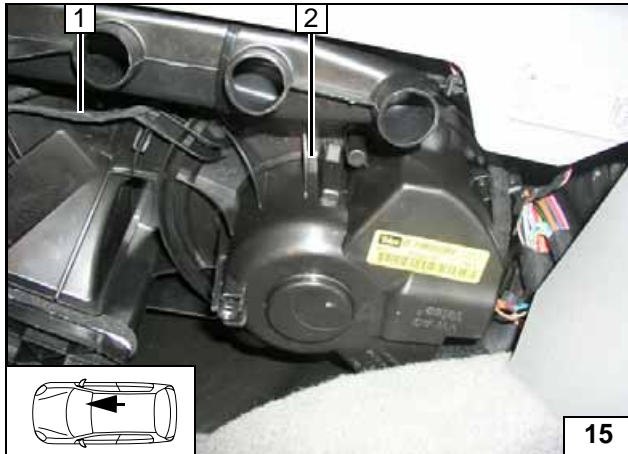
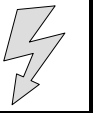

Route wiring harness from IPCU module along original vehicle wires to fan unit.

- 1 IPCU wiring harness
- 2 Fan unit



Detaching fan unit

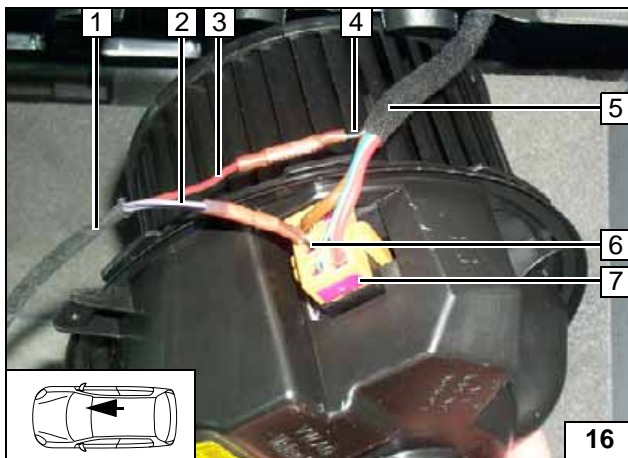

Disconnect fan unit. Produce connections as shown in wiring diagram.

- 1 IPCU wiring harness
- 2 Black/white (sw/ws) wire of IPCU/A
- 3 Red (rt) wire of IPCU/E
- 4 Black/white (sw/ws) wire of Climatronic control unit
- 5 Original vehicle wiring harness
- 6 Black/white (sw/ws) wire of connector T6t/2
- 7 Connector T6t



**Connec-
tion to fan unit**

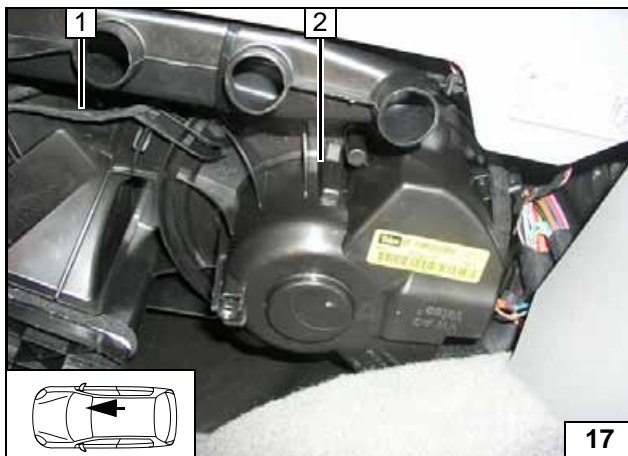

Reinstall fan unit 2.

- 1 IPCU wiring harness



Installing fan unit



Digital timer

- 1 Summer/winter switch
- 2 Digital timer



Installing digital timer

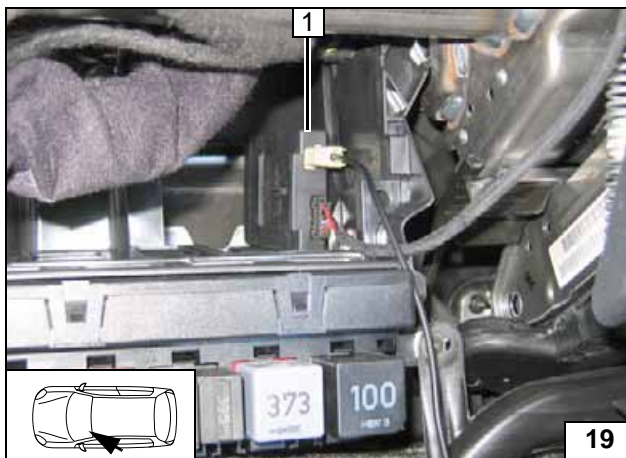

Remote option Telestart

Fasten receiver 1 with adhesive tape.



Installing receiver

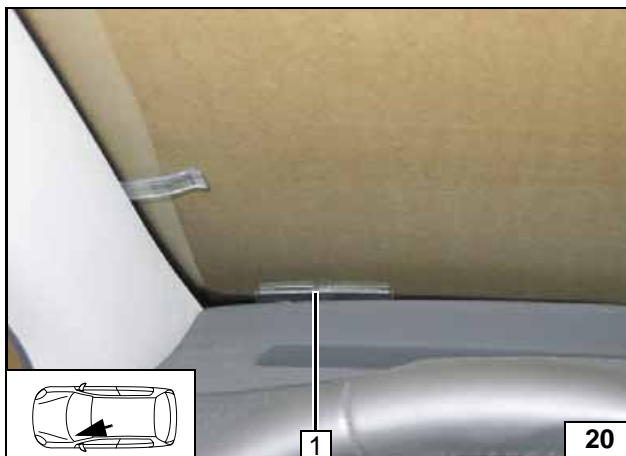

- 1 Antenna

Gluing on antenna



Temperature sensor HTM100

Fasten temperature sensor 1 with adhesive tape.



Installing temperature sensor

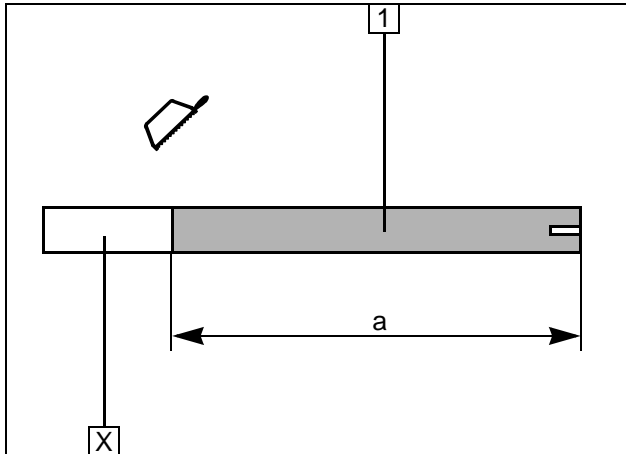
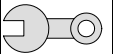

Premounting heater

- 1 Combustion air pipe
a = 250

Discard section X

Cutting combustion air pipe to length

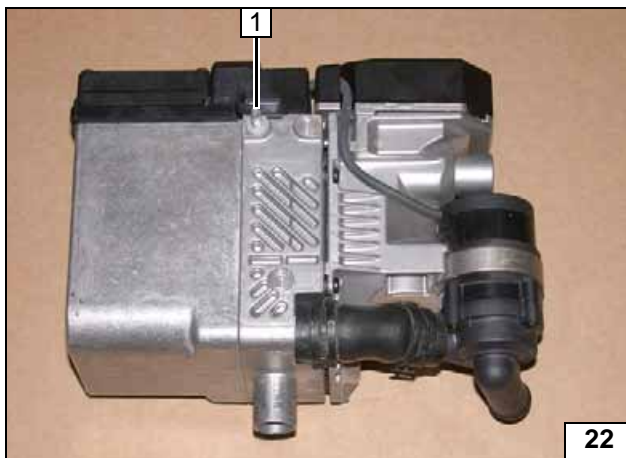

- 1 E-jot stud

Premounting heater

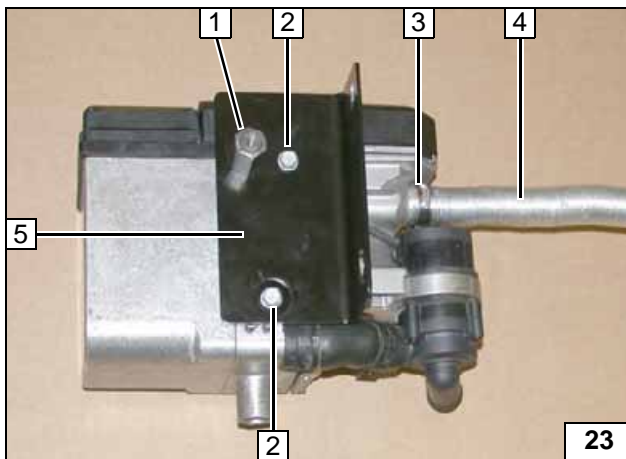

Insert one washer each between heater and bracket at positions 2

- 1 M6x30 spacer nut
- 2 E-jot screw, washer [2x each]
- 3 27 mm dia. hose clamp
- 4 Combustion air pipe
- 5 Bracket



Premounting heater

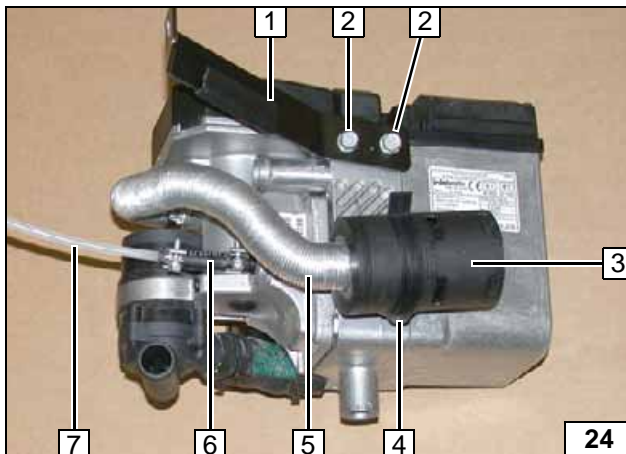

- 1 Strut
- 2 E-jot screw [2x]
- 3 Silencer
- 4 Retaining clip in hole
- 5 Combustion air pipe
- 6 Hose section, 10 mm dia. hose clamp [2x]
- 7 Fuel line

Premounting heater

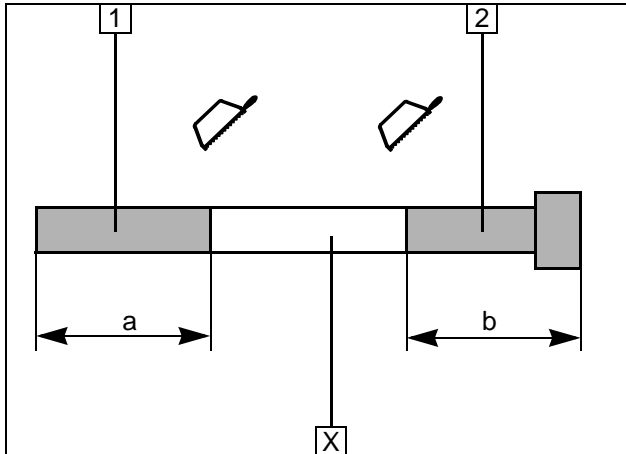
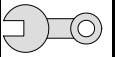

Preparing exhaust

- 1 Exhaust pipe
a = 190
- 2 Exhaust end section
b = 240

Discard section X



**Cutting ex-
haust pipe
to length**

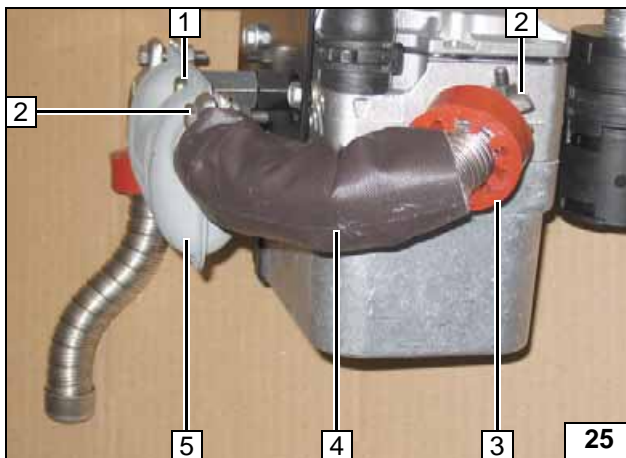

- 1 M6x16 bolt, spring lockwasher
- 2 Hose clamp [2x]
- 3 Red (rt) rubber isolator, without groove
- 4 Exhaust pipe with insulation
- 5 Silencer

**Premount-
ing ex-
haust
system**

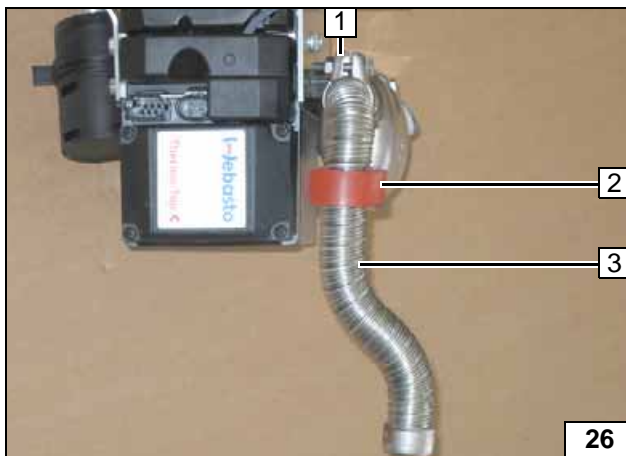

- 1 Hose clamp
- 2 Red (rt) rubber isolator, without groove
- 3 Exhaust end section

**Premount-
ing ex-
haust
system**

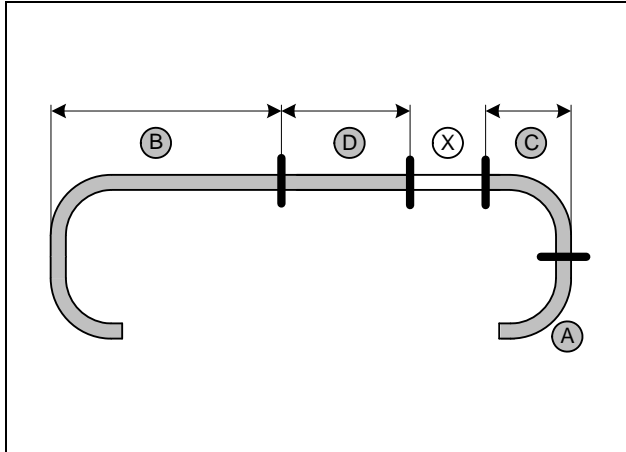
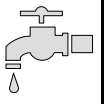

Preparing coolant circuit

1.6 TDI

Discard section X

- B = 840
- C = 100
- D = 720

Cutting hoses to length

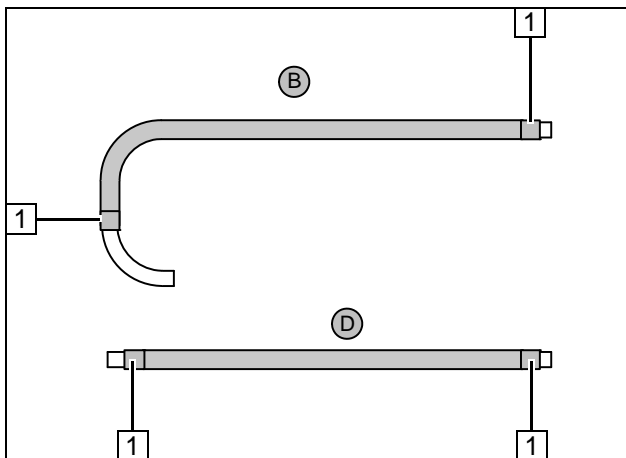

Push braided protection hoses onto hose A and C and cut to length.
Cut heat shrink plastic tubing to length.

- 1 25 mm long heat shrink plastic tubing [4x]

Preparing coolant hoses

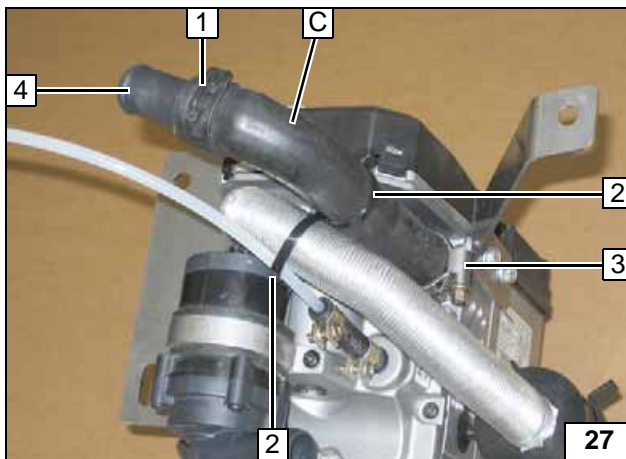

- 1 27 mm dia. spring clip
- 2 Cable tie [2x]
- 3 27 mm dia. hose clamp
- 4 20x20 connecting pipe

Installing Hose C

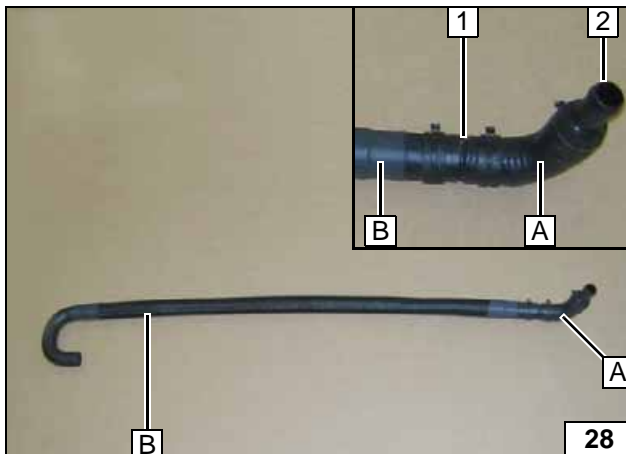

- 1 20x20 mm connecting pipe, 27 mm dia. spring clip [2x]
- 2 18x20 connecting pipe, 27 mm dia. spring clip

Preparing hose A and B.

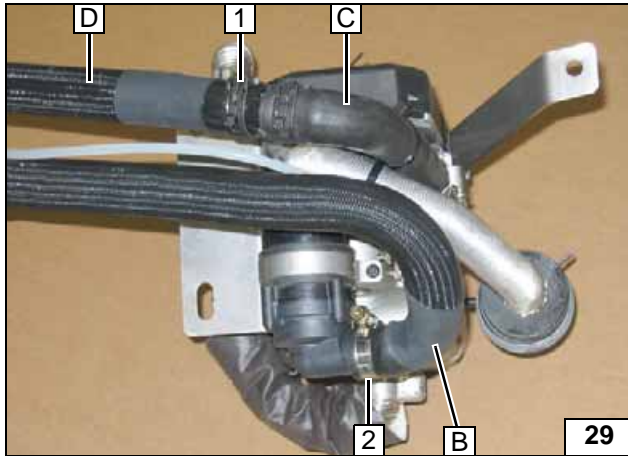
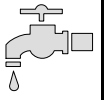

- 1 27 mm dia. spring clip
- 2 27 mm dia. hose clamp

Premounting hoses

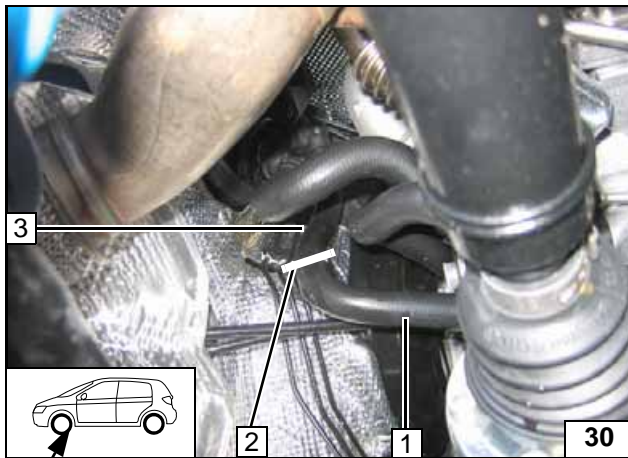

Remove hose on heat exchanger inlet 3.

- 1 Engine outlet
- 2 Cutting point



Cutting point



After preinstalling hose, reinstall heat exchanger inlet on vehicle.

- 1 Original vehicle coupling for heat exchanger
- 2 Black (sw) rubber profile
- 3 25 mm dia. spring clip
- 4 18x20 connecting pipe



Premounting hose on heat exchanger inlet

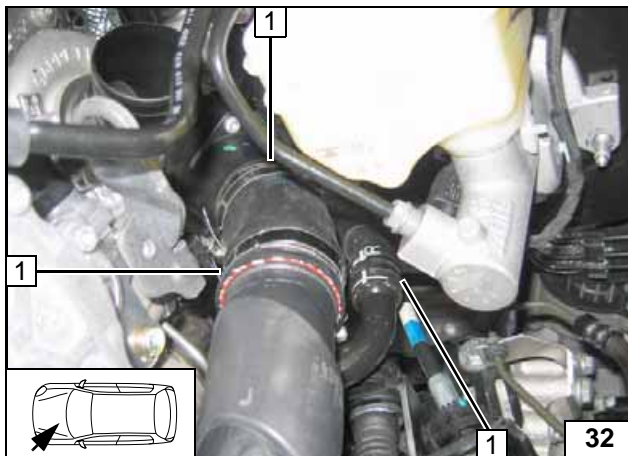

Align original vehicle hose clips 1 [3x] as shown.



Aligning clips

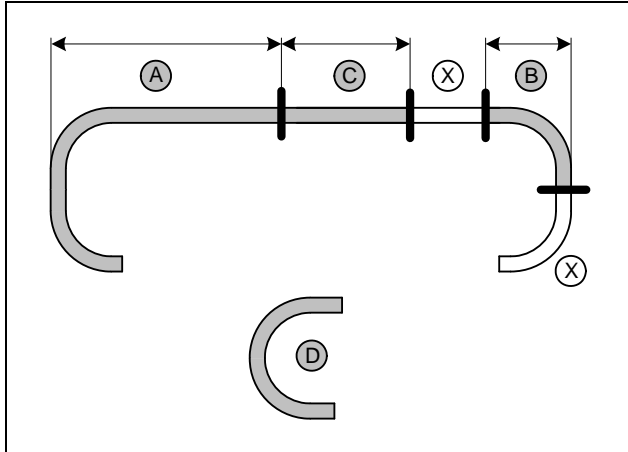
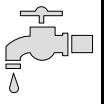

2.0 TDI

Hose **D** = 180° elbow
Discard section **X**

A = 920
B = 100
C = 910



Cutting hoses to length

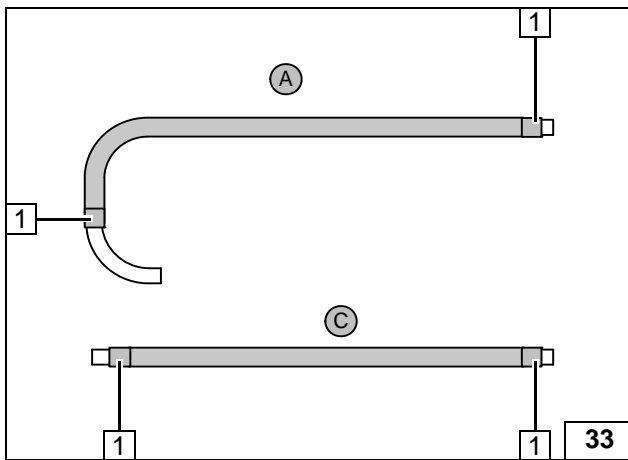

Push braided protection hoses onto hose **A** and **C** and cut to length.
Cut heat shrink plastic tubing to length.

1 25 mm long heat shrink plastic tubing [4x]



Preparing coolant hoses

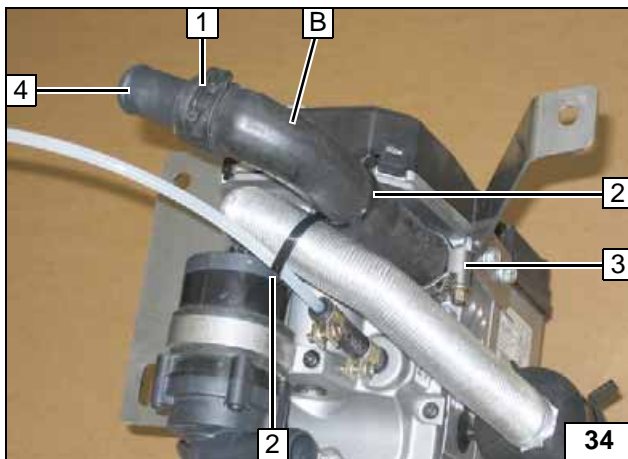

- 1** 27 mm dia. spring clip
- 2** Cable tie [2x]
- 3** 27 mm dia. hose clamp
- 4** 20x20 connecting pipe

Installing Hose B

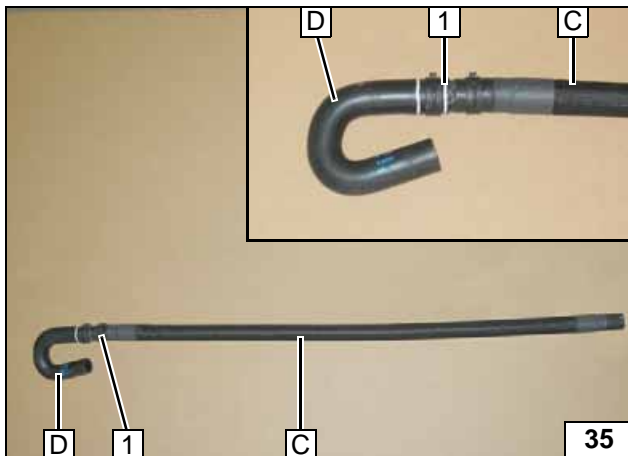

1 20x20 mm connecting pipe, 27 mm dia. spring clip [2x]

Preparing Hose C and D

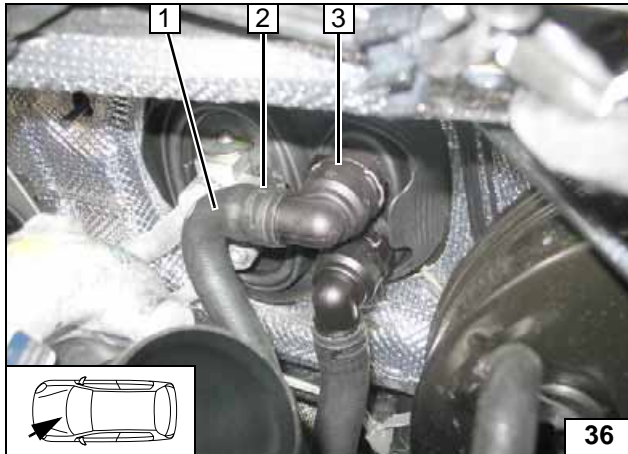
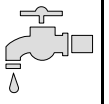

Pull out hose from engine outlet 1. Spring clip 2 will be reused.
Remove coupling of heat exchanger inlet 3.



Cutting point

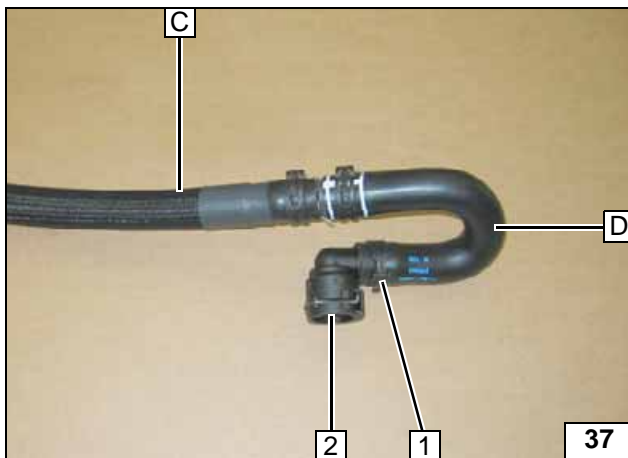

1 Original vehicle spring clip
2 Coupling of heat exchanger inlet

Premounting Hose C and D

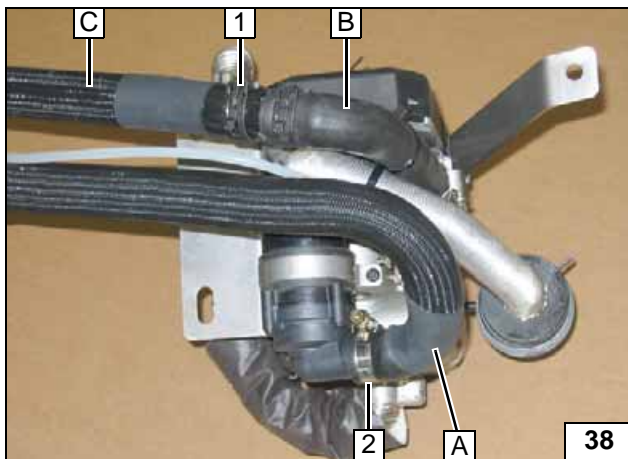

1 27 mm dia. spring clip
2 27 mm dia. hose clamp

Premounting hoses

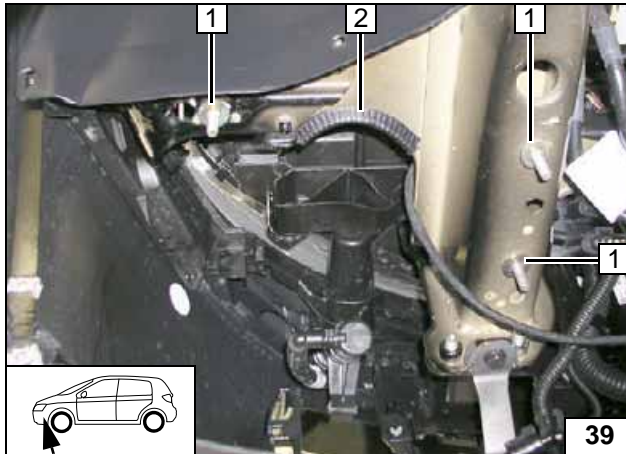
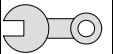

Preparing installation location

Secure large diameter washer against falling with putty etc.

- 1 Large diameter washer on original vehicle stud bolt [3x]
- 2 100 mm edge protection



Preparing installation location

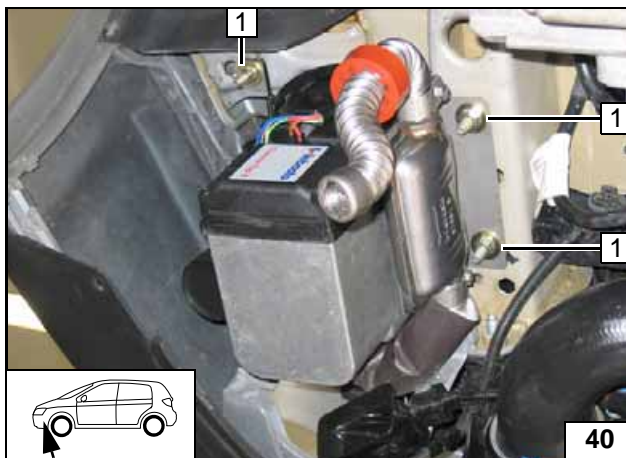

Installing heater

- 1 Large diameter washer, flanged nut M8 [3x]



Installing heater

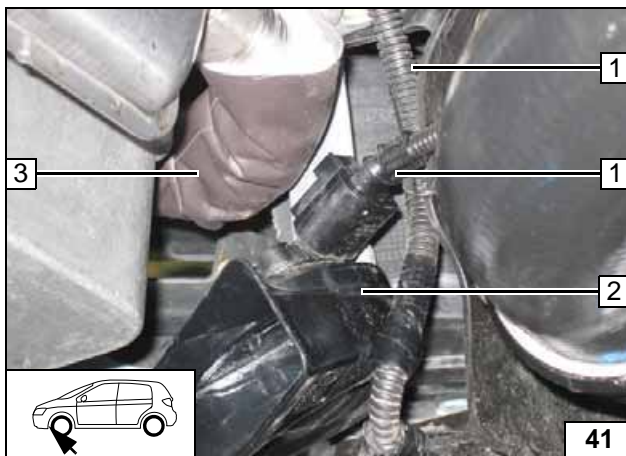

Ensure freedom of movement of exhaust system relative to original vehicle component and lines.

- 1 Original vehicle wiring harnesses (secured with cable ties)
- 2 Horn
- 3 Exhaust pipe



Aligning exhaust system

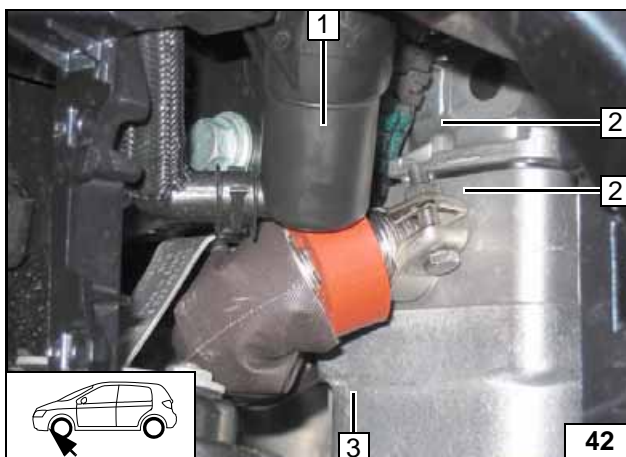

Ensure freedom of movement of exhaust system relative to original vehicle component and lines.

- 1 Exhaust pipe
- 2 Original vehicle wiring harnesses (secured with cable ties)
- 3 Horn



Aligning exhaust system

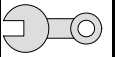

Punch through perforation of heater cover at Position 2. Insert clip-type cable tie and fasten wiring harness of heater 1.



Mounting wiring harness

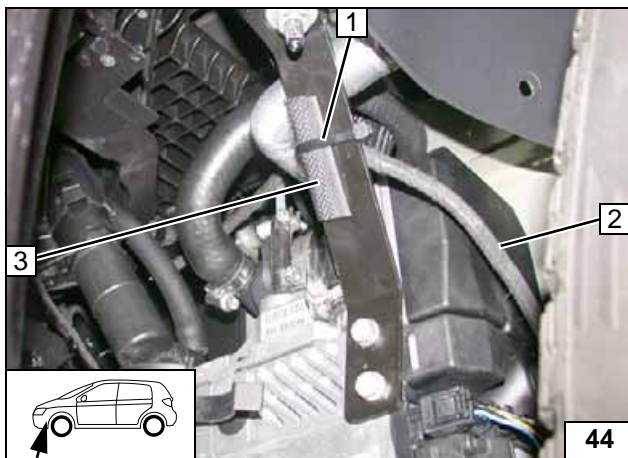

Combustion air silencer tied away for demonstration purposes.

- 1 Cable tie
- 2 Wiring harness of heater
- 3 50 mm edge protection



Fastening wiring harness



Fuel

CAUTION!

Open the vehicle's fuel tank cap, ventilate the tank and then re-close the tank lock.

Catch any fuel running off with an appropriate container.

Install fuel line and metering-pump wiring harness so that they are protected against stone impact. Unless specified otherwise, always fasten using cable ties. Mount the fuel line and wiring harness with rub protection on sharp edges.

WARNING!

The fuel line and wiring harness are routed to the metering pump in as shown in the wiring harness routing diagram.

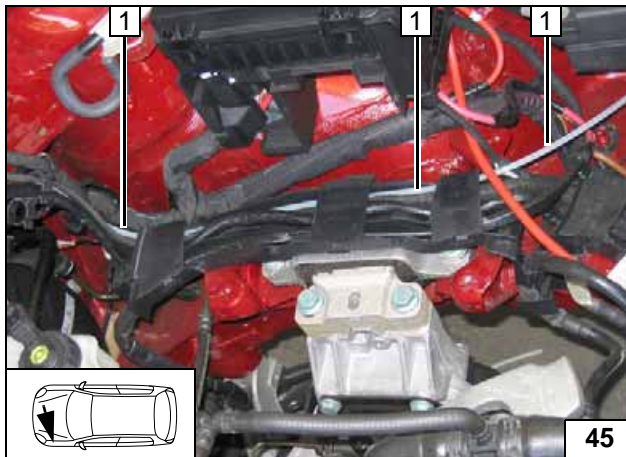

1 Fuel line

Installing fuel line

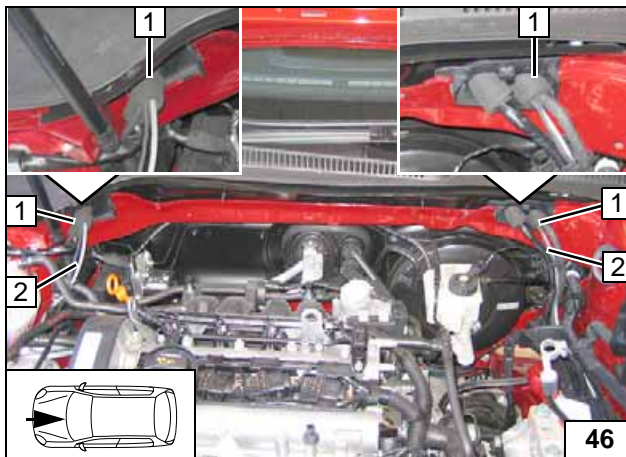

Route fuel line and wiring harness of metering pump **2** in coolant reservoir to right and fasten on original vehicle lines with cable ties. Pay particular attention to freedom of movement of wiper linkage. Route fuel line and wiring harness of metering pump to underbody in wiring duct.

1 Existing pass through [2x]



Installing lines

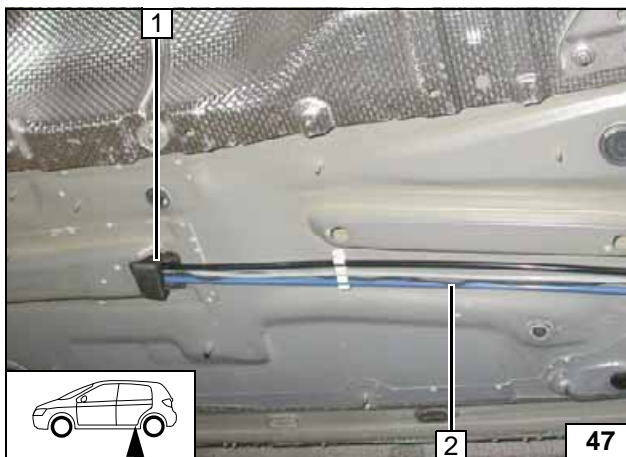

Route fuel line and wiring harness of metering pump along original vehicle fuel lines **2** to fuel tank.

1 Line duct



Installing lines

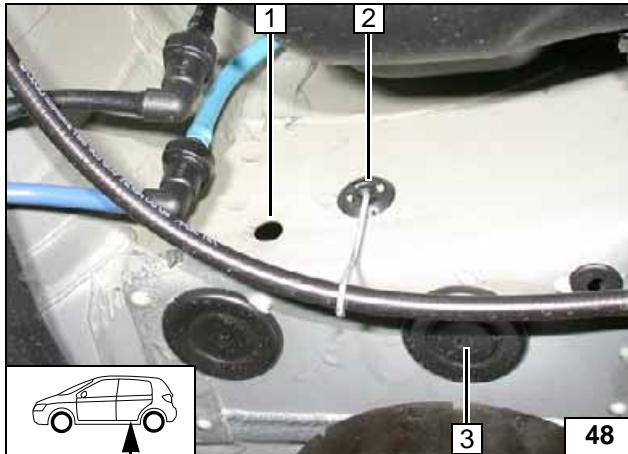

Remove sealing plug **3** for installation. Remove bracket of handbrake cable at Position **2** and install at Position **1**.



Moving bracket

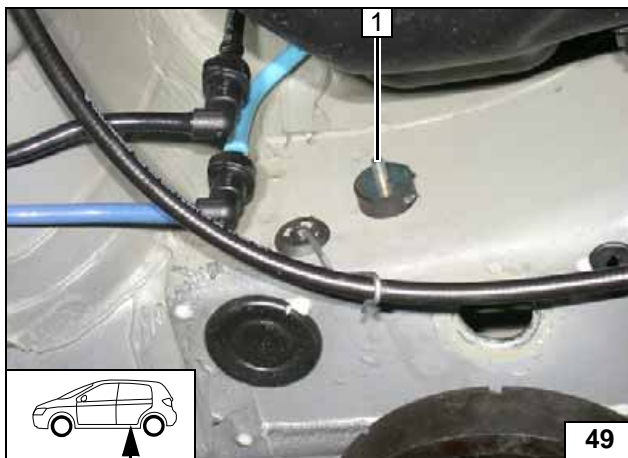

1 Silent block, large diameter washer, flanged nut

Installing silent block

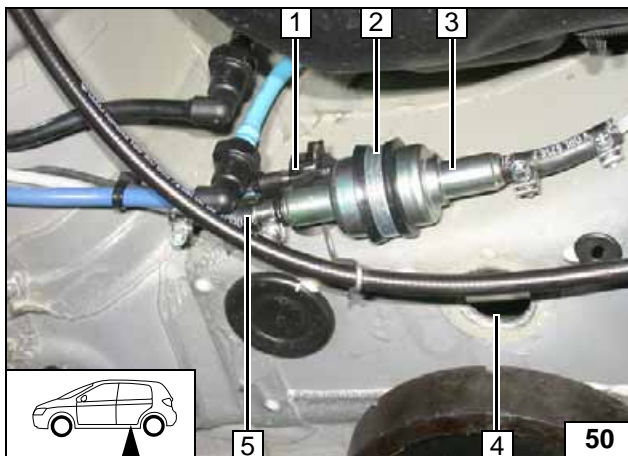

After installation, re-insert sealing plug at Position **4**.



- 1** Wiring harness of metering pump, connector mounted
- 2** Rubber-coated p-clamp, flanged nut, silent block
- 3** Metering pump
- 5** Fuel line, hose section, 10 mm dia. hose clamp [2x]

Installing metering pump

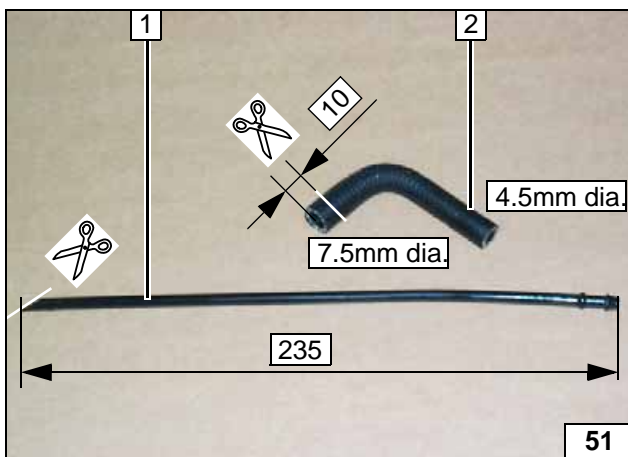

- 1** Standpipe
- 2** Moulded hose

Cutting standpipe and moulded hose to length

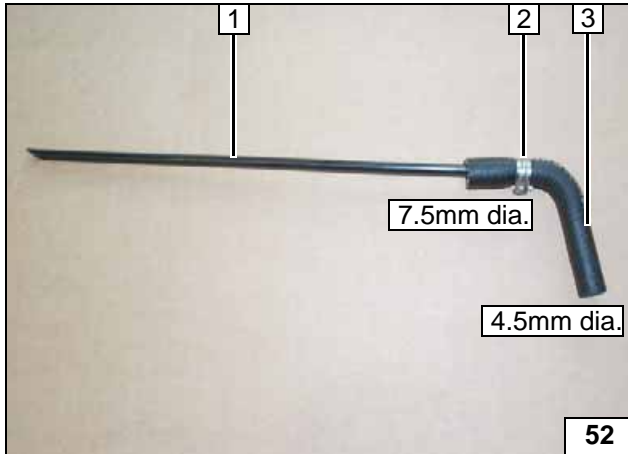
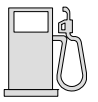

10 mm dia. Caillau clamp **2** in centre between beads on end of standpipe.

- 1 Standpipe
- 3 Moulded hose



Premounting standpipe and moulded hose

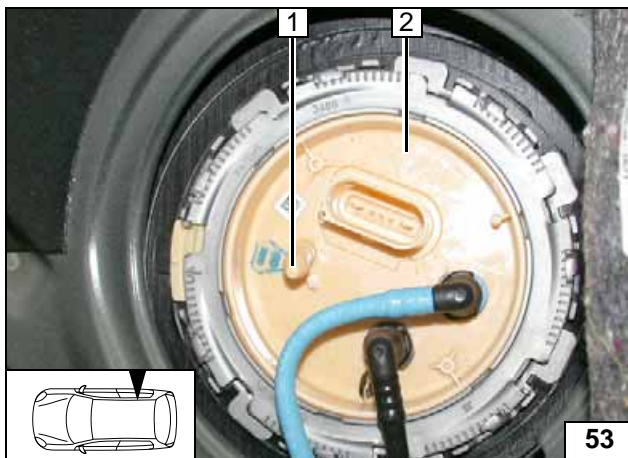

Cut 3 mm off blind plug **1**.

- 2 Fuel-tank sending unit



Cutting off blind plug

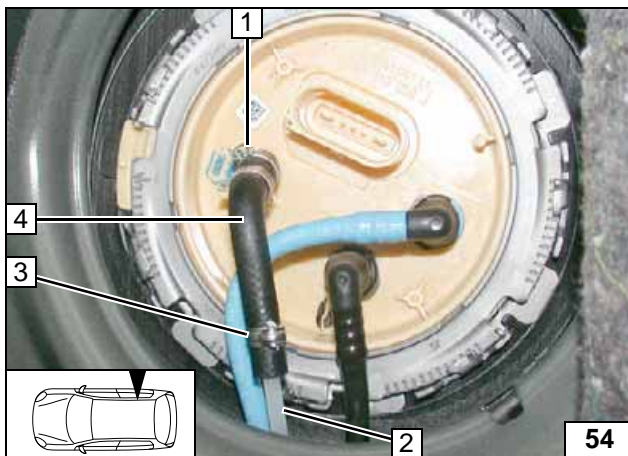

Ensure sufficient distance to adjacent components, especially to fuel gauge.

- 1 13.5 mm dia. Caillau clamp
- 2 Fuel line
- 3 10 mm dia. Caillau clamp
- 4 Moulded hose with standpipe



Connection to fuel-tank sending unit

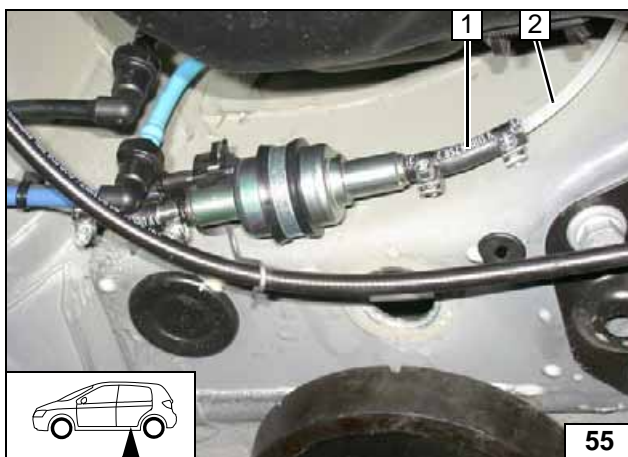

- 1 Hose section, 10 mm dia. hose clamp [2x]
- 2 Fuel line

Connecting metering pump

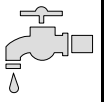

1.6 TDI coolant circuit





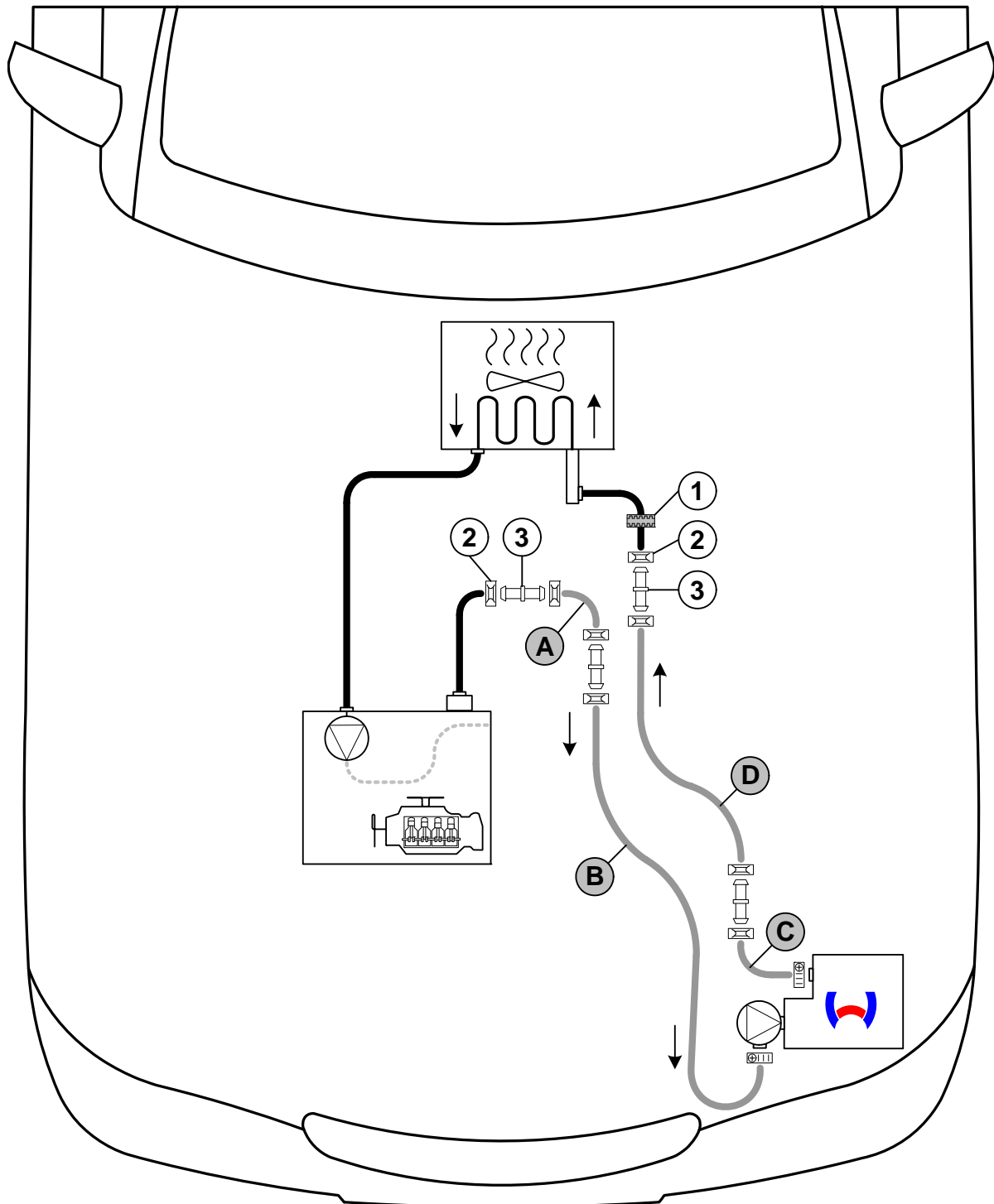

WARNING!

Any coolant running off should be collected using an appropriate container. Install hoses so that they are kink-free. Unless specified otherwise, always fasten using cable ties. Position clamps so that no other hose can be damaged! When installing the hoses, the heater must be filled with coolant. The connection should be "inline" based on the following diagram:



Hose routing diagram

All spring clips without a specific designation  = 27 mm dia. All connecting pipes without a specific designation  = dia. 20x20 mm. All hose clamps  = 20-27 mm dia.! **1** = Black (sw) rubber isolator. **2** = 25 mm dia. spring clip  **3** = Connecting pipe  = 18x20 mm dia.



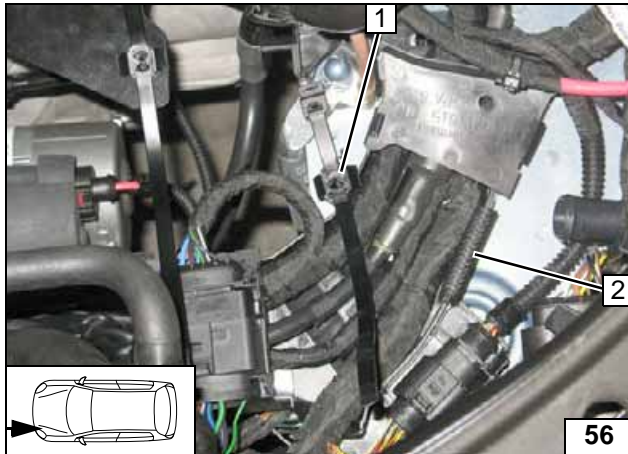

6 mm dia. hole at Position 1. When drilling holes, watch lines located behind them. Installing clip-type cable tie 1.

2 50 mm edge protection



Installing clip-type cable tie

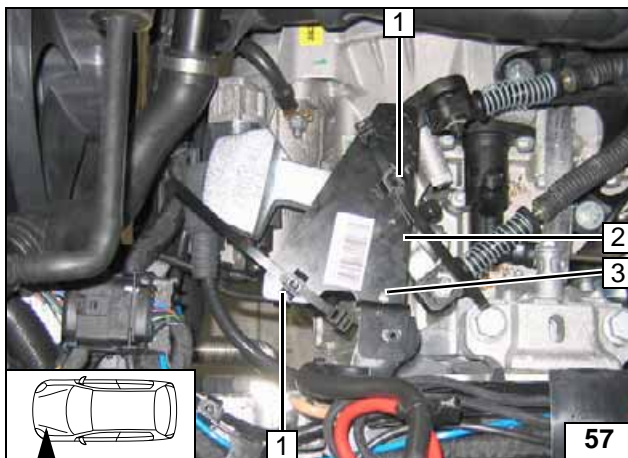

Insert clip-type cable tie 1 [2x] in holes of bracket for coolant hoses 2.

3 M6x20 bolt, flanged nut, existing hole



Installing bracket

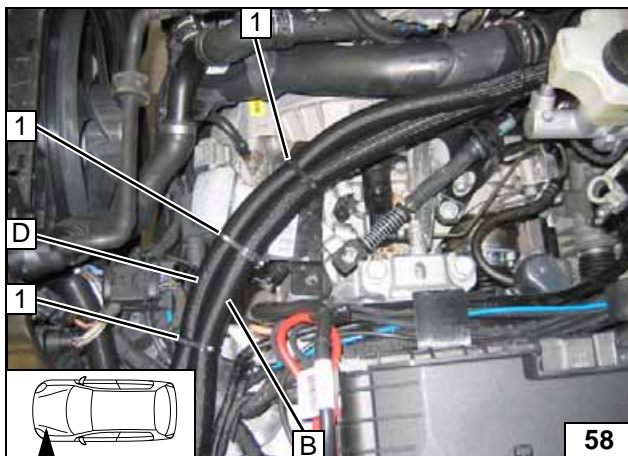

Close clip-type cable tie 1 [3x].



Routing in engine compartment

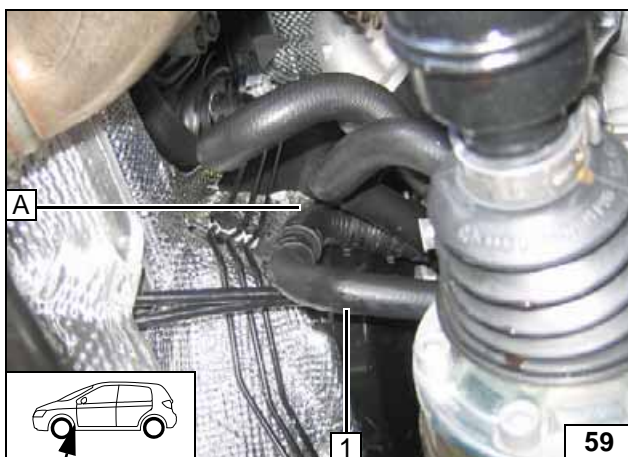

1 Hose of engine outlet

Connecting engine outlet

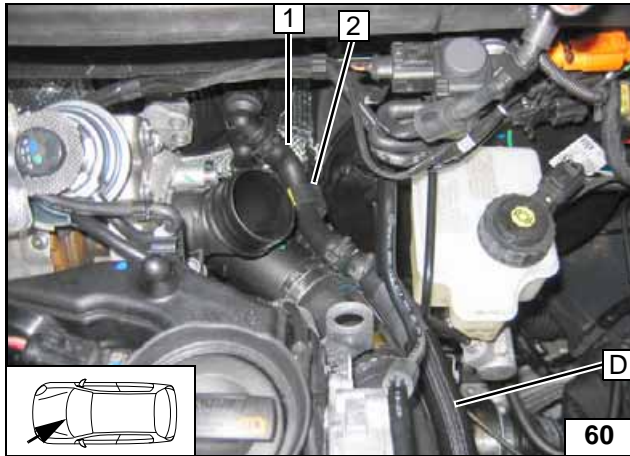

- 1 Hose on heat exchanger inlet
- 2 Position black (sw) rubber isolator

**Connect-
ing heat
exchanger
inlet**



Fix Hose **B** and **D** with cable tie **1** to original vehicle hose.



**Aligning
hoses**

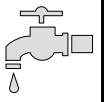

2.0 TDI coolant circuit





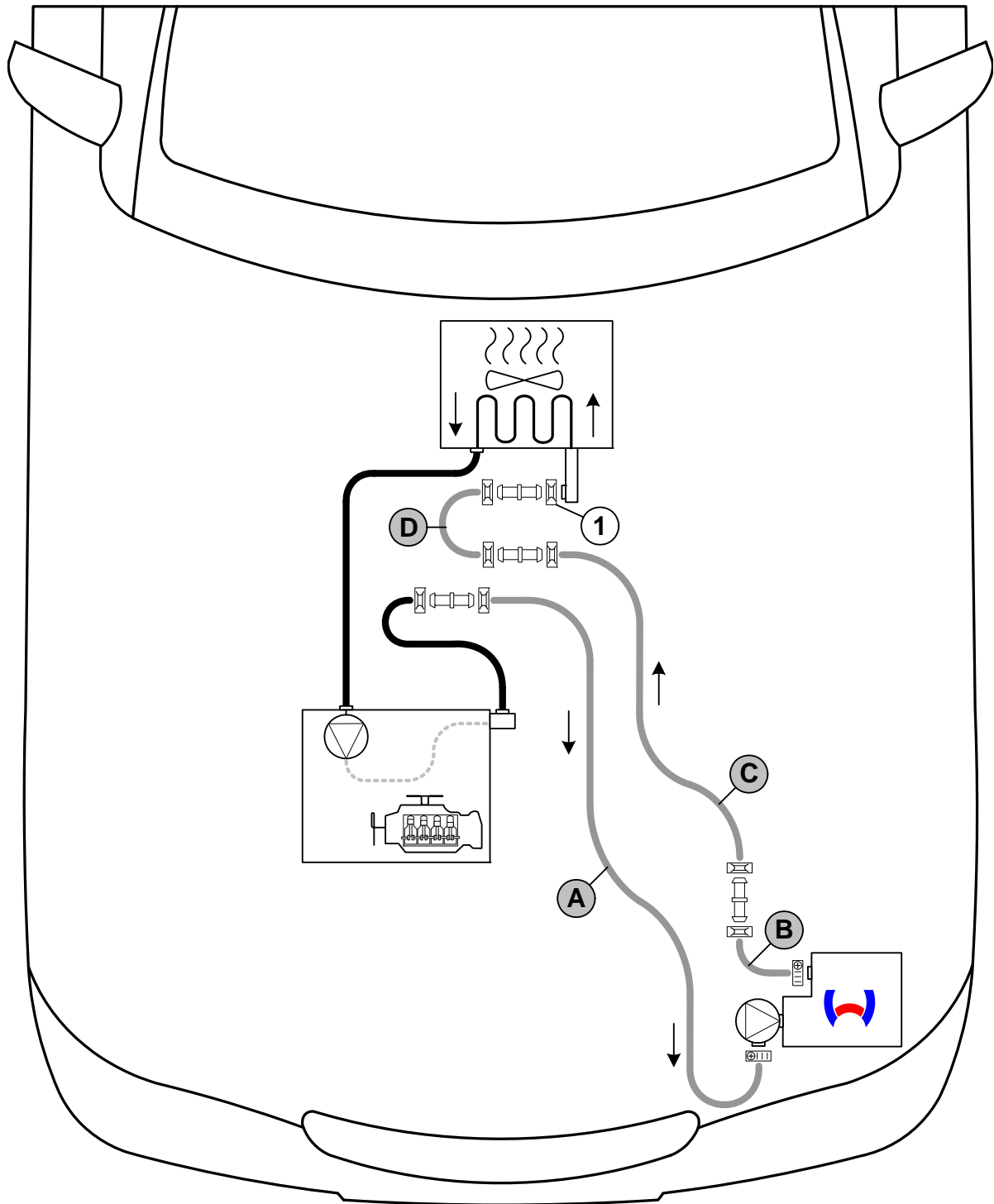

WARNING!

Any coolant running off should be collected using an appropriate container. Install hoses so that they are kink-free. Unless specified otherwise, always fasten using cable ties. Position clamps so that no other hose can be damaged! When installing the hoses, the heater must be filled with coolant. The connection should be "inline" based on the following diagram:



Hose routing diagram

All spring clips  = 27mm dia. 1 = Original vehicle spring clip .

All connecting pipes  = 20x20 mm dia. All hose clamps  = 20-27 mm dia.!



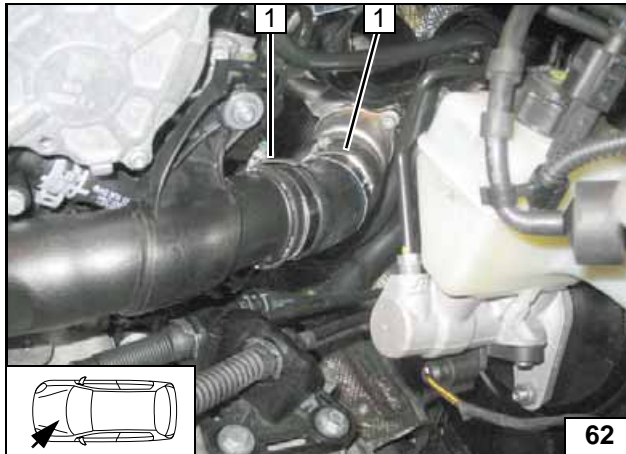
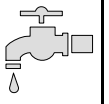

Align original vehicle hose clips **1** [2x] as shown (turn to left).



Aligning clips

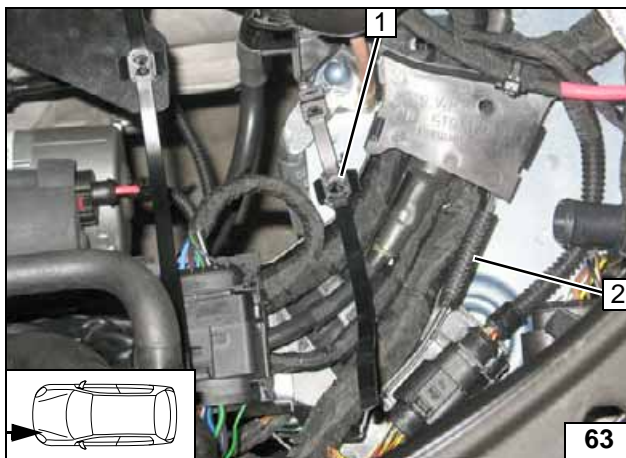

6 mm dia. hole at Position **1**. When drilling holes, watch lines located behind them. Installing clip-type cable tie **1**.

2 50 mm edge protection



Installing clip-type cable tie

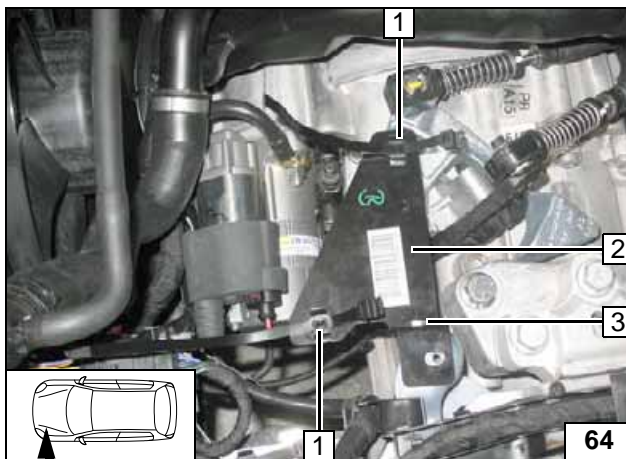

Insert clip-type cable tie **1** [2x] in holes of bracket for coolant hoses **2**.

3 M6x20 bolt, flanged nut, existing hole



Installing bracket

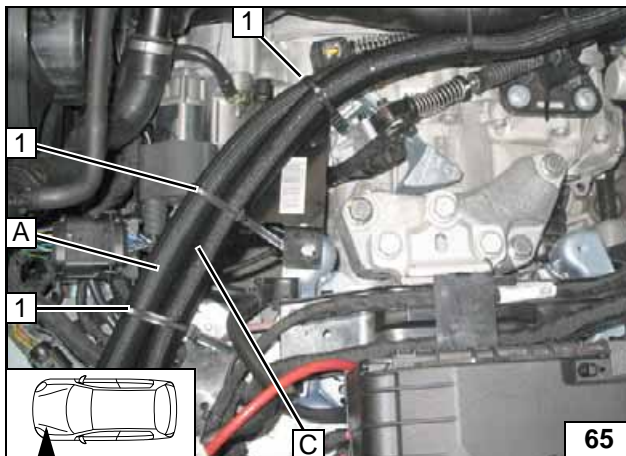

Close clip-type cable tie **1** [3x].



Routing in engine compartment

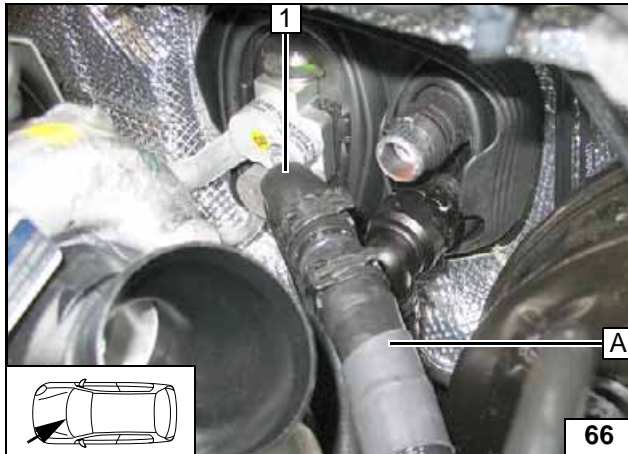
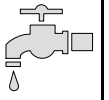

1 Hose of engine outlet

Connect-
ing engine
outlet

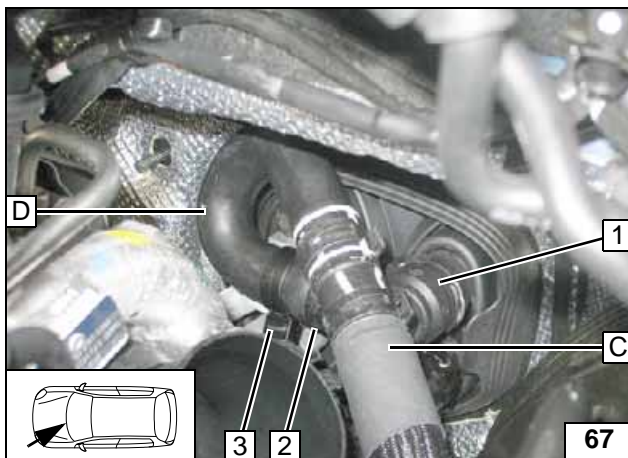

1 90° connection of heat exchanger inlet
2 Original vehicle spring clip
3 Spacer bracket

Connect-
ing heat
exchanger
inlet

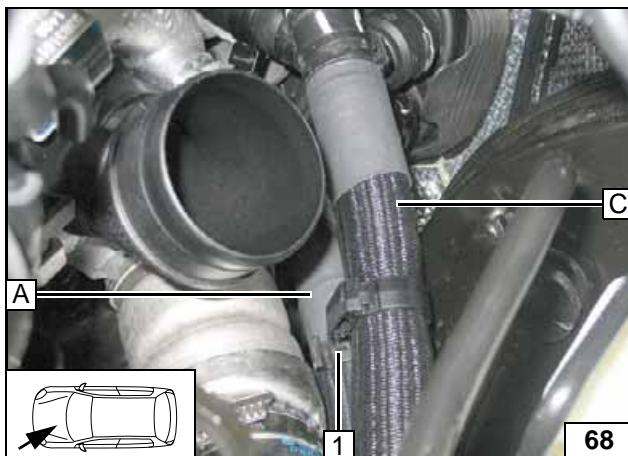

1 Lockable spacer bracket

Install-
ing
spacer
bracket

Fix Hose **A** and **C** with cable tie.

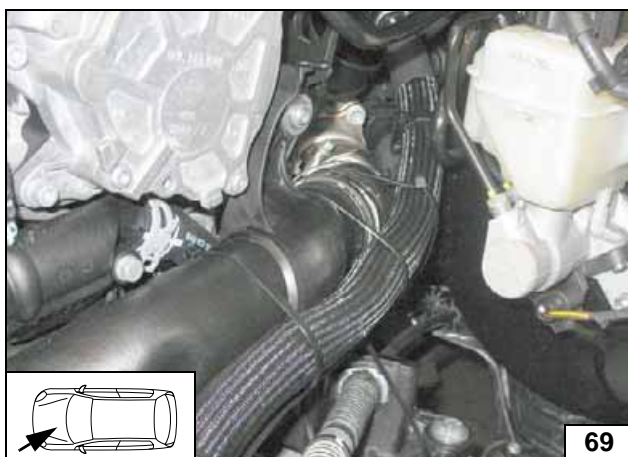

Align-
ing
hoses

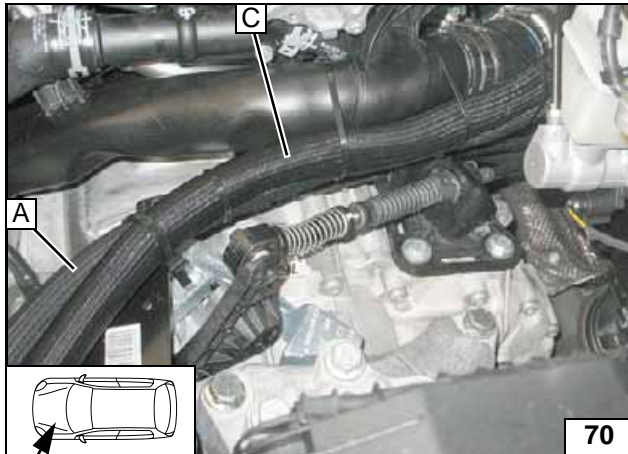
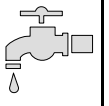

Fix Hose **A** and **C** with cable tie. Ensure sufficient distance to neighbouring components.



Aligning hoses

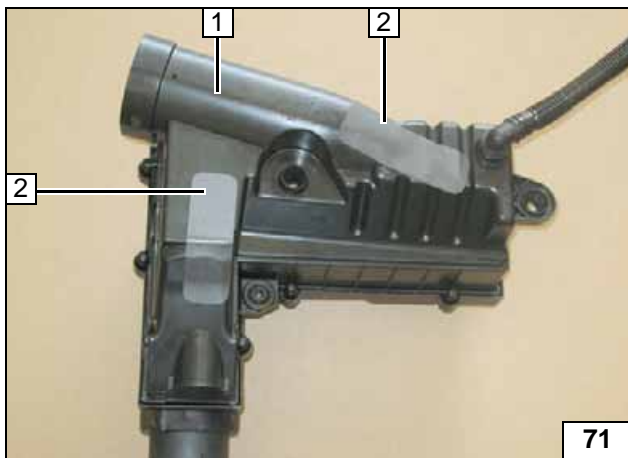

All vehicles

The position of the drain pipe may vary. Glue rub protection **2** [2x] as shown on air filter box **1**.



Preparing air filter box

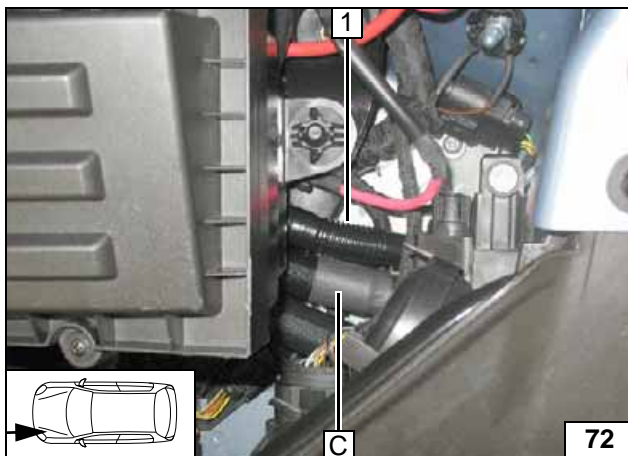

Version 1:

If drain pipe **1** exists as shown, route it parallel to the coolant hose **C/D**.



Installing air cleaner housing

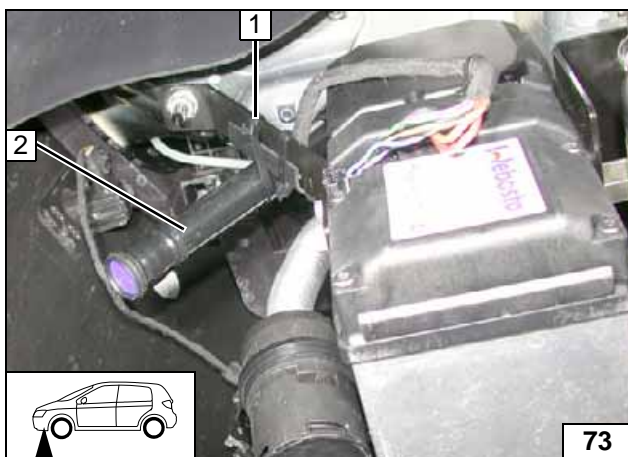

If drain pipe **2** exists as shown, fasten with cable tie **1** to strut.



Fastening drain pipe of air filter box

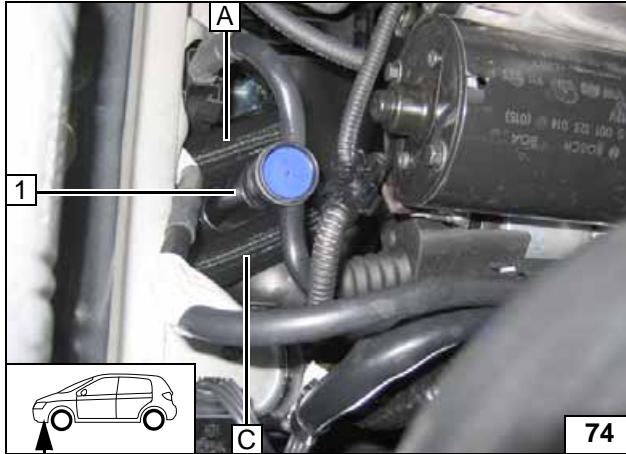
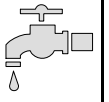

Version 2:

If drain pipe **1** exists as shown, route it between the coolant hoses **A/B** and **C/D**.



**Installing
air cleaner
housing**

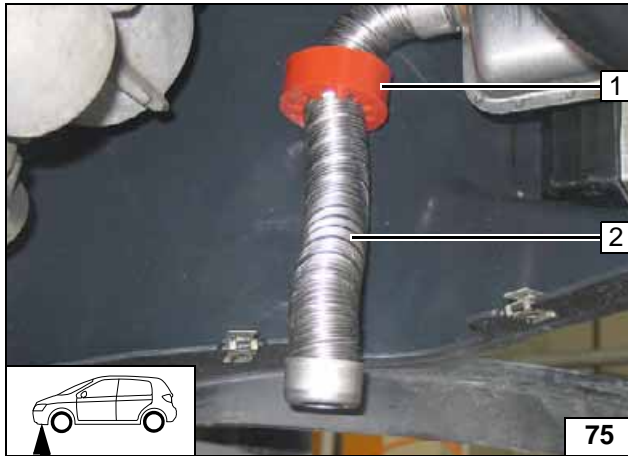
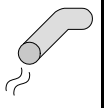

Exhaust gas

Align exhaust end section **2** and rubber isolator **1** as shown.
Ensure sufficient distance of exhaust end section from wheel well trim.



Installing wheel well trim

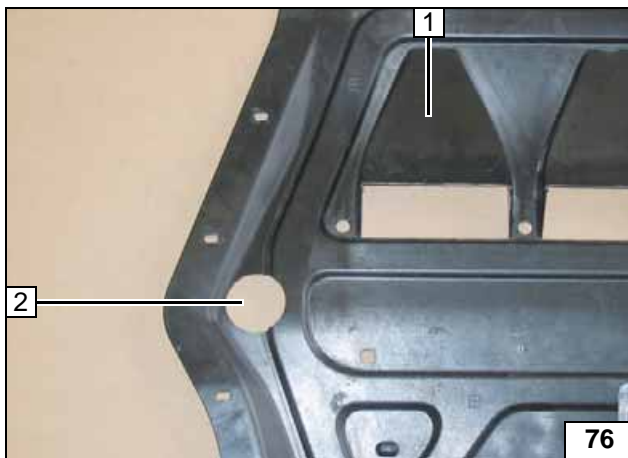

If insulation exists, remove it at Position **2**.

- 1 Underride protection
- 2 42 mm dia. hole



Hole in underride protection

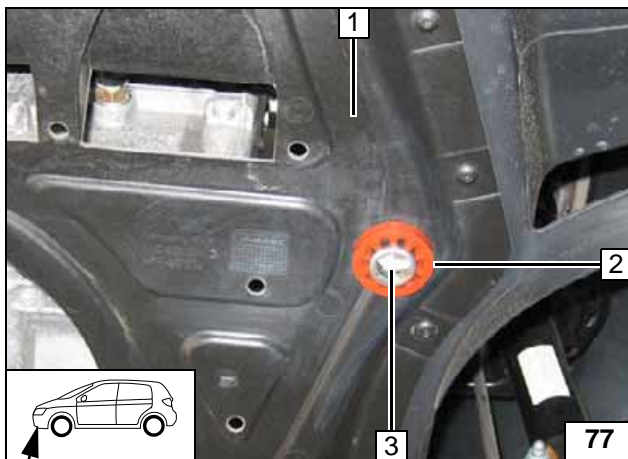

Align exhaust end section **3** flush on red (rt) rubber isolator **2**.

- 1 Underride protection



Mounting rubber isolator

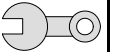

Final Work

WARNING!

Reassemble the disassembled components in reverse order. Check all hoses, clamps and all electrical connections for firm seating. Insulate all loose wires and tie back.

Only use manufacturer-approved coolant. Spray the heater components with anti-corrosion wax (Tectyl 100K, Order No. 111329).

- **Connect the battery**
- **Fill and bleed the coolant circuit according to the vehicle manufacturer's specifications.**
- **Adjust digital timer, teach Telestart**
- **Make settings on A/C control panel according to the "Operating Instructions for End Customer".**
- **Place instruction signboard "Switch off parking heater before refuelling" in the area of the filler neck**
- **For initial start-up and function test, refer to installation instructions**



Webasto AG
Postfach 80
D-82132 Stockdorf / Germany
National Hotline: 01805 93 22 78
(14 Cent aus dem deutschen Festnetz)
Hotfax: 0395 5592 353
Hotmail: hotline@webasto.de
<http://www.webasto.de>

Operating Instructions for End Customer

Please remove page and add to the vehicle operating instructions.



Note:

We recommend matching the heating time to the driving time.

Heating time = driving time

Example:

For a driving time of approx. 20 min. (in one direction), we recommend not exceeding a switch-on time of 20 min.

If the summer/winter switch option has been installed, this must be switched in accordance with the time of year. The heater will then heat in the position Winter  and in the position Summer  it will only switch on the vehicle fan to ventilate the vehicle interior.

For vehicles with passenger compartment monitoring , this is to be deactivated in addition to the vehicle settings of the heating operation .

For information on deactivation, please see the vehicle owner's manual.

Before parking the vehicle, make the following settings:

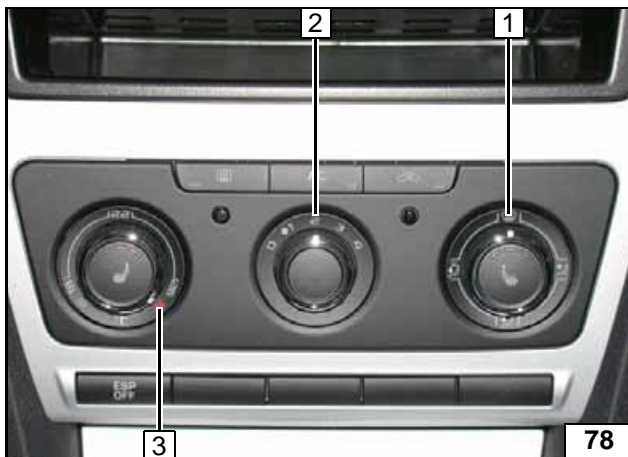

- 1 Direct air outlet toward windscreen
- 2 Set fan to level "1", or possibly "2"
- 3 Set temperature to "max."

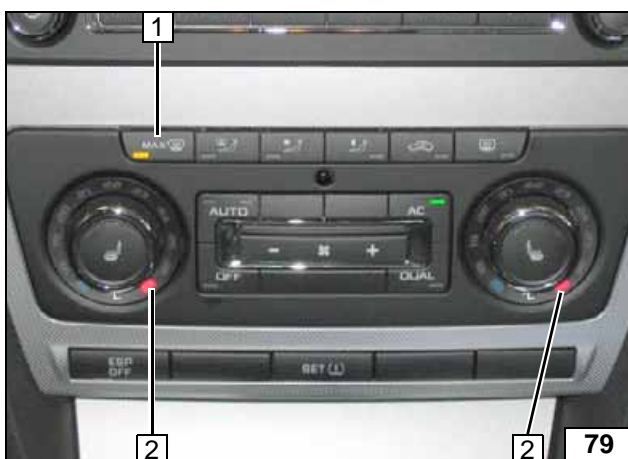

- 1 Direct air outlet toward windscreen
- 2 Set temperature on both sides to "HI".



Climatic

Climatronic