

Water Heater

Thermo Top Evo Parking Heater



Installation Documentation Citroen C5 / Peugeot 407

Validity

Manufacturer	Model	Type	EG-BE No. / ABE
Citroen	C5	R....	e1 * 2001/116 * 0347 * ...
Citroen	C5	R....	e1 * 2001/116 * 0360 * ...

Manufacturer	Model	Type	EG-BE No. / ABE
Peugeot	407	6	e2 * 2001/116 * 0292 * ...
Peugeot	407	6	e2 * 2001/116 * 0296 * ...
Peugeot	407 Coupe	6	e2 * 2001/116 * 0328 * ...
Peugeot	407	6	e2 * 2001/116 * 0346 * ...
Peugeot	407	6	e2 * 2001/116 * 0369 * ...

Motorisation	Fuel	Transmission type	Output in kW	Displacement in cm ³	Engine code
1.6	Petrol	SG	115	1598	5FV
1.8	Petrol	SG	92	1749	6FY
2.0	Petrol	SG	103	1997	RFJ
1.6 HDI	Diesel	SG	80	1560	9 HZ
2.0 HDI	Diesel	SG / AG	100	1997	RHR
2.0 HDI	Diesel	SG	103	1997	RHF
2.0 HDI	Diesel	SG	120	1997	RHH
2.2 HDI	Diesel	SG / AG	125	2179	4HT
2.2 HDI	Diesel	AG	150	2179	4HL

SG = Manual transmission

AG = automatic transmission

From Model Year 2008

Left-hand drive vehicle

Verified equipment variants:

Automatic air-conditioning

Front fog lights

Front fog lightsHeadlight washer system

Not verified:

Passenger compartment monitoring

Alarm system

Manual air-conditioning

Cruise control

Total installation time:

approx. 8.5 hours

Citroen C5 / Peugeot 407

Table of Contents

Validity	1	Preparing Installation Location	13
Necessary Components	2	Installing Heater	13
Installation Overview	2	Coolant Circuit 1.8 / 2.0 B and 1.6 D	14
Information on Total Installation Time	2	Coolant Circuit 2.0 D RHR / RHF	19
Information on Operating and Installation Instructions	3	Coolant Circuit 2.0 D RHH	22
Information on Validity	4	Coolant Circuit 1.6 B and 2.2 D	25
Technical Information	4	Fuel	30
Explanatory Notes on Document	4	Final Work	34
Preliminary Work	5	Template for Petrol Fuel Standpipe	35
Heater Installation Location	5	Template for Diesel Fuel Standpipe	36
Preparing Electrical System	6	Operating Instructions for End Customer	37
Electrical System	8		
Fan Controller	9		
Digital Timer Option	11		
Remote option (Telestart)	11		

Necessary Components

- Delivery scope of Citroen C5 / Peugeot 407 2008 Petrol: **1316396B** or
- Delivery scope of Citroen C5 / Peugeot 407 2008 Diesel: **1316397B**
- Heater control in accordance with price list and upon consultation with end customer
- In case of Telestart, indicator lamp in accordance with price list and in consultation with end customer

Installation Overview

Legend:

1. Heater
2. Fuse holder of engine compartment
3. Fuse holder of passenger compartment
4. Circulating pump
5. Digital Timer
6. Metering pump

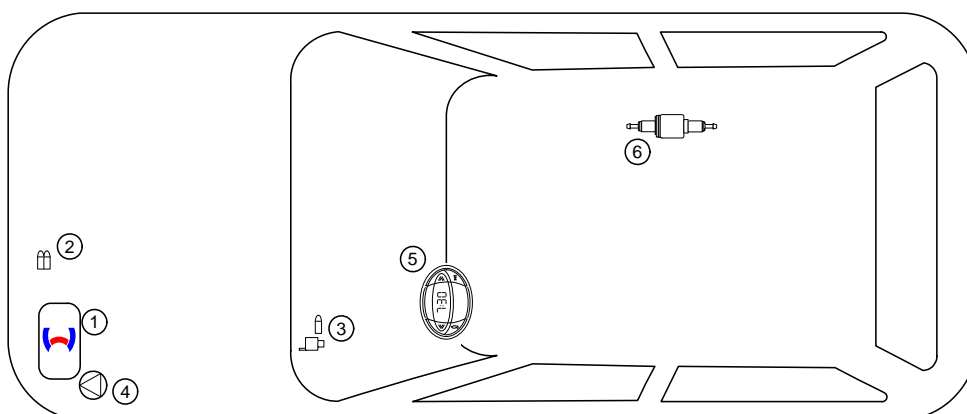

Information on Total Installation Time

The total installation time includes the time needed for mounting and demounting of the vehicle-specific components, the heater specific installation time and all other times required for the system integration and initial start-up of the heater.

The total installation time may vary for vehicle equipment other than provided.

Information on Operating and Installation Instructions

1 Important notes (not complete)

1.1 Installation and repair



The improper installation or repairing of Webasto heating and cooling systems can cause fire or the leakage of deadly carbon monoxide, leading to serious injury or death.



To install and repair Webasto heating and cooling systems you need to have completed a special company training course and have the appropriate technical documentation, special tools and special equipment.



Installation and repair may ONLY be carried out by persons trained and certified in a Webasto training course. NEVER try to install or repair Webasto heating or cooling systems if you have not completed a Webasto training course, you do not have the necessary technical skills and you do not have the technical documentation, tools and equipment available to ensure that you can complete the installation and repair work properly.

Only use genuine Webasto parts. See the Webasto air and water heaters accessories catalogue for this purpose.

1.2 Operation

To ensure safe operation, we recommend having the heater checked every two years by an authorised Webasto dealer, especially when used over a long period and/or under extreme environmental conditions.

Do not operate the heater in closed rooms due to the danger of poisoning and suffocation.

Always switch off the heater before refuelling.

The heater may only be used with the prescribed fuel Diesel (DIN EN 590) or petrol (DIN EN 227).

The heater may not be cleaned with a high-pressure cleaner.

1.3 Please note

ALWAYS follow all Webasto installation and operating instructions and observe all warnings.

To become familiar with and understand all functions and properties of the heater, the operating instructions must be read carefully and observed at all times.

For proper, safe installation and repair work, the installation instructions with all warnings and safety information must be carefully read and observed at all times. Please always contact a workshop authorised by Webasto for all installation and repair work.

Important

Webasto shall assume no liability for defects, damage and injuries resulting from a failure to observe the installation, repair and operating instructions of the information contained in them.

This liability exclusion particularly applies to improper installations and repairs, installations and repairs by untrained persons or in the case of a failure to use genuine spare parts.

The liability due to culpable disregard to life, limb or health and due to damage or injuries caused by a wilful or reckless breach of duty remain unaffected, as does the obligatory product liability.

Installation should be carried out according to the general, standard rules of technology. Unless specified otherwise, fasten hoses, wires and wiring harnesses to original vehicle lines and wiring harnesses using cable ties. Insulate loose wires and tie back. Connectors on electronic components have to audibly click into place during installation.

Sharp edges should be fitted with rub protection. Spray unfinished body areas, e.g. drilled holes, with anti-corrosion wax (Tectyl 100K, Order No. 111329).

Observe the instructions and guidelines of the respective vehicle manufacturer for demounting and mounting vehicle specific components!

The initial startup is to be executed with the Webasto Thermo Test Diagnosis.

When installing an IPCU, the corresponding settings must be checked or adjusted before the installation.

2 Statutory regulations governing installation

Guidelines	Thermo Top Evo
Heating Directive ECE R122	E1 00 0258
EMC Directive ECE R10	E1 03 5627

Note

The regulations of these guidelines are binding in the scope of the Directive 70/156/EEC and/or 2007/46/EC (for new vehicle models from 29/04/2009) and should also be observed in countries in which there are no special regulations.

Important

Failure to follow the installation instructions will result in the invalidation of the type approval for the heater and therefore invalidation of the general **homologation of the vehicle**.

Note

For vehicles with an EU permit, no entry in accordance with § 19 Sub-Section 4 of Annex VIII b to the Road Traffic Act is required.

2.1 Excerpt from the directive 2001/56/EC Appendix VII for the installation of the heater

Beginning of excerpt.

ANNEX VII

REQUIREMENTS FOR COMBUSTION HEATERS AND THEIR INSTALLATION

1. GENERAL REQUIREMENTS

1.7.1. A clearly visible tell-tale in the operator's field of view shall inform when the combustion heater is switched on or off.

2. VEHICLE INSTALLATION REQUIREMENTS

2.1. Scope

2.1.1. Subject to paragraph 2.1.2. combustion heaters shall be installed according to the requirements of this Annex.

2.1.2. Vehicles of category O having liquid fuel heaters are deemed to comply with the requirements of this Annex.

2.2. Positioning of heater

2.2.1. Body sections and any other components in the vicinity of the heater must be protected from excessive heat and the possibility of fuel or oil contamination.

2.2.2. The combustion heater shall not constitute a risk of fire, even in the case of overheating. This requirement shall be deemed to be fulfilled if the installation ensures an adequate distance to all parts and suitable ventilation, by the use of fire resistant materials or by the use of heat shields.

2.2.3. In the case of M2 and M3 vehicles, the heater must not be positioned in the passenger compartment. However, an installation in an effectively sealed envelope which also complies with the conditions in paragraph 2.2.2 may be used.

2.2.4. The label referred to in paragraph 1.4 or a duplicate, must be positioned so that it can be easily read when the heater is installed in the vehicle.

2.2.5. Every reasonable precaution should be taken in positioning the heater to minimise the risk of injury and damage to personal property.

2.3. Fuel supply

2.3.1. The fuel filler must not be situated in the passenger compartment and must be provided with an effective cap to prevent fuel spillage

2.3.2. In the case of liquid fuel heaters, where a supply separate to that of the vehicle is provided, the type of fuel and its filler point must be clearly labelled

2.3.3. A notice, indicating that the heater must be shut down before refuelling, must be affixed to the fuelling point. In addition a suitable instruction must be included in the manufacturer's operating manual.

2.4. Exhaust system

2.4.1. The exhaust outlet must be located so as to prevent emissions from entering the vehicle through ventilators, heated air inlets or opening windows.

2.5. Combustion air inlet

2.5.1. The air for the combustion chamber of the heater must not be drawn from the passenger compartment of the vehicle.

2.5.2. The air inlet must be so positioned or guarded that blocking by rubbish or luggage is unlikely.

2.6. Heating air inlet

2.6.1. The heating air supply may be fresh or recirculated air and must be drawn from a clean area not likely to be contaminated by exhaust fumes emitted either by the propulsion engine, the combustion heater or any other vehicle source.

2.6.2. The inlet duct must be protected by mesh or other suitable means.

2.7. Heating air outlet

2.7.1. Any ducting used to route the hot air through the vehicle must be so positioned or protected that no injury or damage could be caused if it were to be touched.

2.7.2. The air outlet must be so positioned or guarded that blocking by rubbish or luggage is unlikely.

End of excerpt.

In multilingual versions the German language is binding.

Citroen C5 / Peugeot 407

Information on Validity

This installation documentation applies to Citroen C5 / Peugeot 407 Petrol and diesel vehicles - for validity, see page 1 - from model year 2008 and later, assuming technical modifications to the vehicle do not affect installation, any liability claims excluded. Depending on the vehicle version and equipment, modifications may be necessary during installation with respect to these "installation instructions".

Vehicle and engine types, equipment variants and other specifications not listed in this installation documentation have not been tested. However, installation according to this installation documentation may be possible.

Technical Information

Special Tools

- Hose clamp pliers for auto-tightening hose clamps
- Hose clamp pliers for Clic hose clamps of type W
- Automatic wire stripper 0.2 - 6mm²
- Crimping pliers for cable lug / tab connector 0.5 - 6mm²
- Torque wrench for 2.0 - 10 Nm
- Hose clamping pliers
- Metric thread-setter kit
- Webasto Thermo Test Diagnosis with current software

Dimensions

- All dimensions in mm.

Tightening torque values

- Tightening torque values of 5x13 heater bolts = 8Nm.
- Tightening torque values of 5x15 retaining plate of water connection piece bolts = 7Nm.
- Tighten other bolt connections in accordance with manufacturer's instructions or in accordance with state-of-the-art-technology.

Explanatory Notes on Document

You will find an identification mark on the outside top right corner of the page in question to provide you with a quick overview of the individual working steps.

Special features are highlighted using the following symbols:

Mechanical system



Electrical System



Coolant Circuit

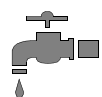

Combustion Air

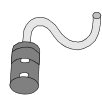

Fuel



Exhaust gas



Software



Special risk of injury or fatal accidents.



Specific risk of damage to components.



Specific risk of fire or explosion.



Reference to general installation instructions of the Webasto component or to vehicle specific documents of the manufacturer



Reference to a special technical feature.



The arrow in the vehicle icon indicates the position on the vehicle and the viewing angle.

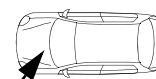
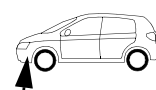

Citroen C5 / Peugeot 407

Preliminary Work

Vehicle

- Open the fuel tank cap.
- Ventilate the fuel tank.
- Close the fuel tank cap again.
- Depressurise the cooling system.
- Disconnect and completely remove the battery with carrier.
- Remove the air filter together with the intake hose.
- Remove the left-hand wheel well trim.
- Remove the left front wheel.
- Remove the front underride protection.
- Remove the right-hand underbody trim.
- Remove the right rear underride protection.
- Fold over the right-hand rear seat
- Open the right-hand tank-fitting service lid.
- Remove the fuel-tank sending unit in accordance with the manufacturer's instructions.
- Remove the instrument panel trim on the driver's side (only with Telestart).
- Remove the footwell trim on the driver's side.
- Remove the driver's side storage compartment.

Heater

- Remove years that do not apply from the type and duplicate label.
- Attach the duplicate label (type label) in the appropriate place in the engine compartment.

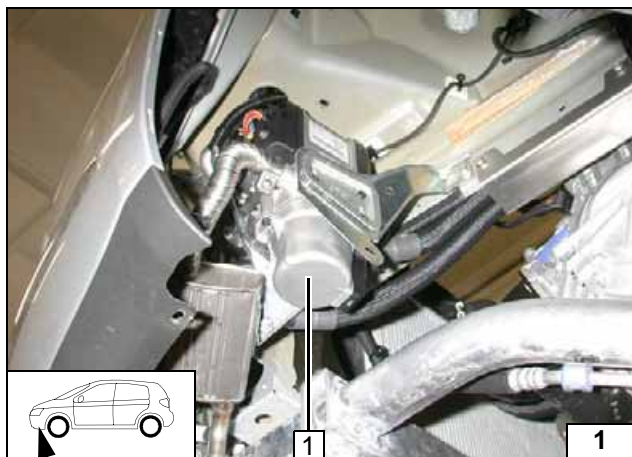

Heater Installation Location

1 Heater

Installation location

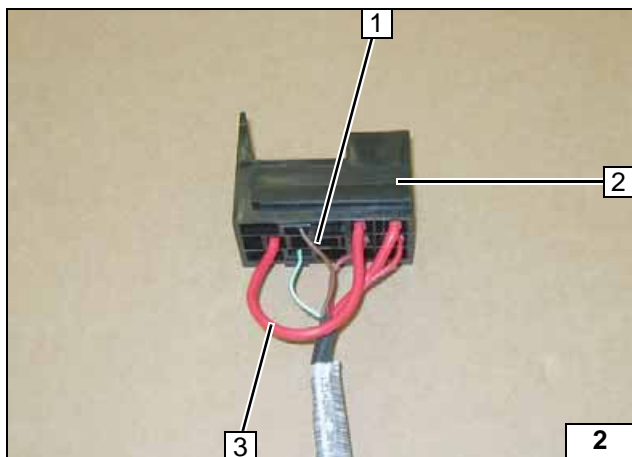

Preparing Electrical System

Wire sections retain their numbering throughout the entire document.

Remove brown (br) wire 1 from socket K1/85 and detach tab receptacle. Remove red (rt) wire 3 from K1/87 and socket F4 and discard.

- 2 Fuse holder of passenger compartment



Preparing fuse holder of passenger compartment

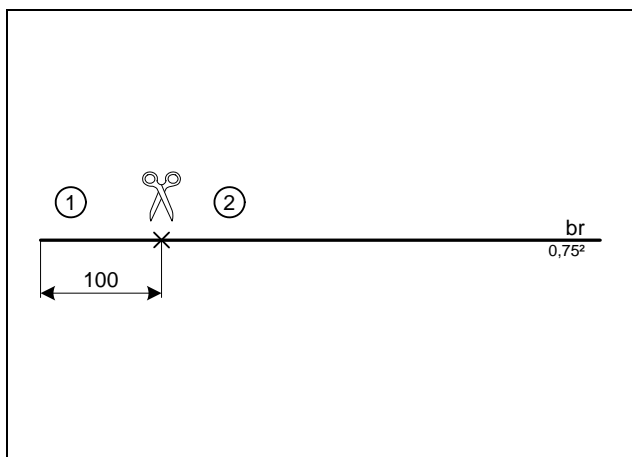

Cutting wire to length

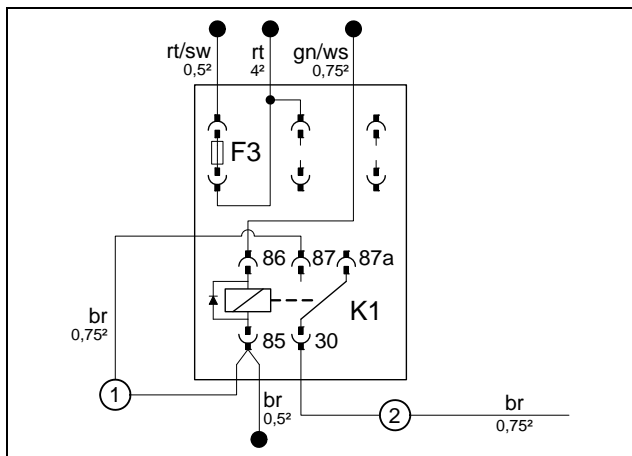

Connect brown (br) wire 1 to K1/85 and connect with brown (br) wire to K1/85. Connect brown (br) wire 2 to K1/30.



Preparing fuse holder of passenger compartment

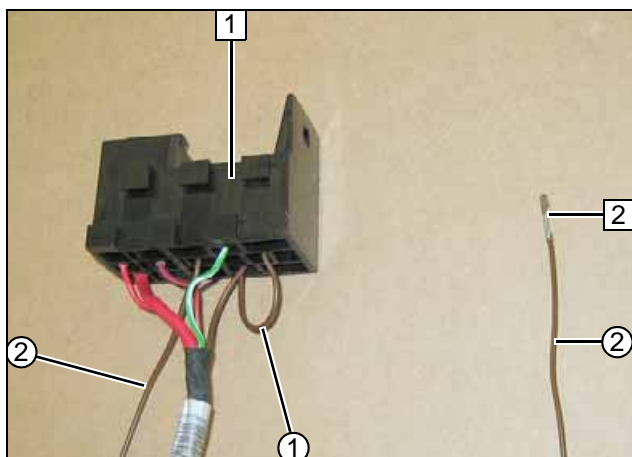

Crimp microtimer 2 to brown (br) wire 2 .

- 1 Fuse holder of passenger compartment
- 1 Brown (br) wire
- 2 Brown (br) wire



Preparing fuse holder of passenger compartment

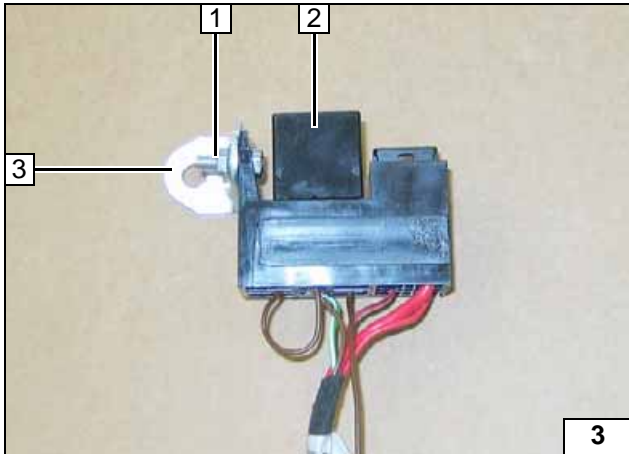
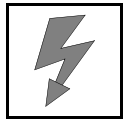

- 1 M5x16 bolt, large diameter washer [2x], nut
- 2 Relay mounted
- 3 Angle bracket

Preparing fuse holder of passenger compartment

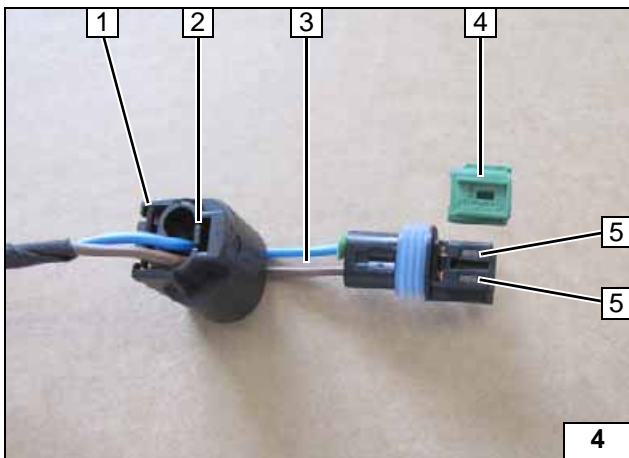

Complete connector of metering pump after routing. Pin assignment is not relevant.

- 1 Connector housing
- 2 Lock
- 3 Blue / brown (bl / br) wires
- 4 Coding
- 5 Timer lock



Dismantling connector



Electrical System

Fuse holder of engine compartment

- 1 Original vehicle bolt, large diameter washer
- 2 M5x16 bolt, large diameter washer [2x], retaining plate of fuse holder, nut
- 3 F1-2 fuses mounted
- 4 Angle bracket

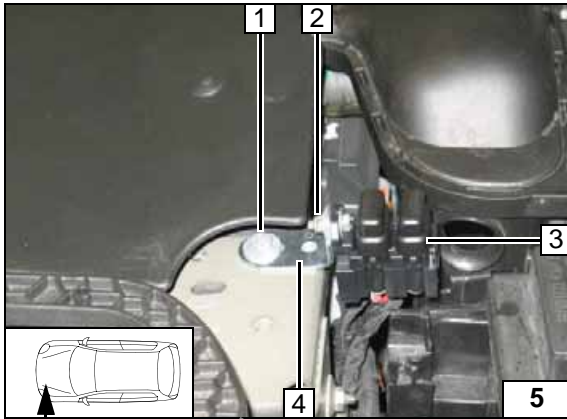

Positive and earth wire

- 1 Positive wire
- 2 Earth wire on original vehicle earth support point

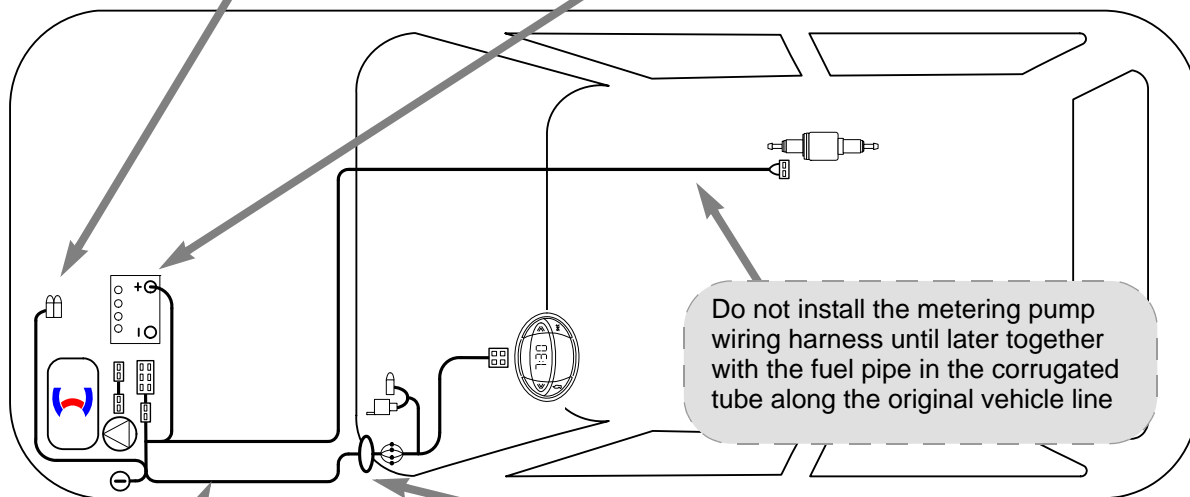
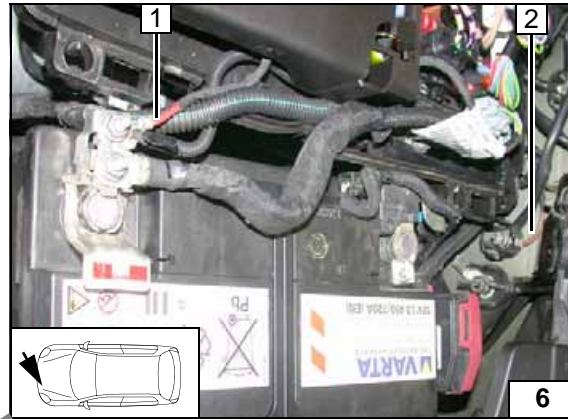

Wiring harness routing diagram

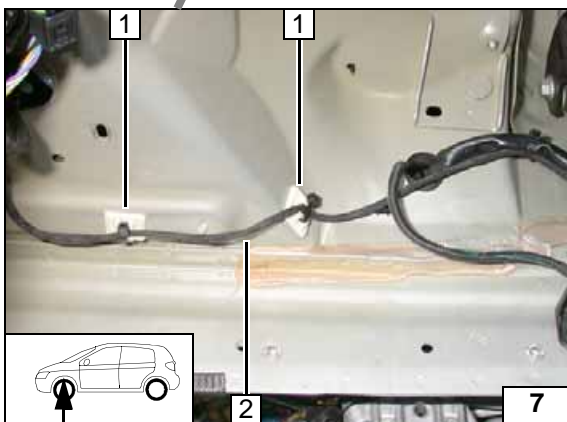

Wiring harness routing

Fasten wiring harness of fuse holder in engine compartment 2 in wheel well with adhesive base 1 and cable tie [total of 4x each].

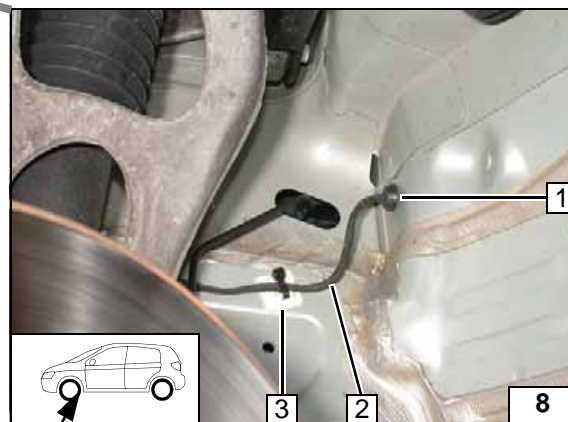

Wiring harness pass through of passenger compartment

- 1 Drill out existing protective rubber plug
- 2 Wiring harness, fuse holder, engine compartment
- 3 Adhesive base, cable tie



Fan Controller

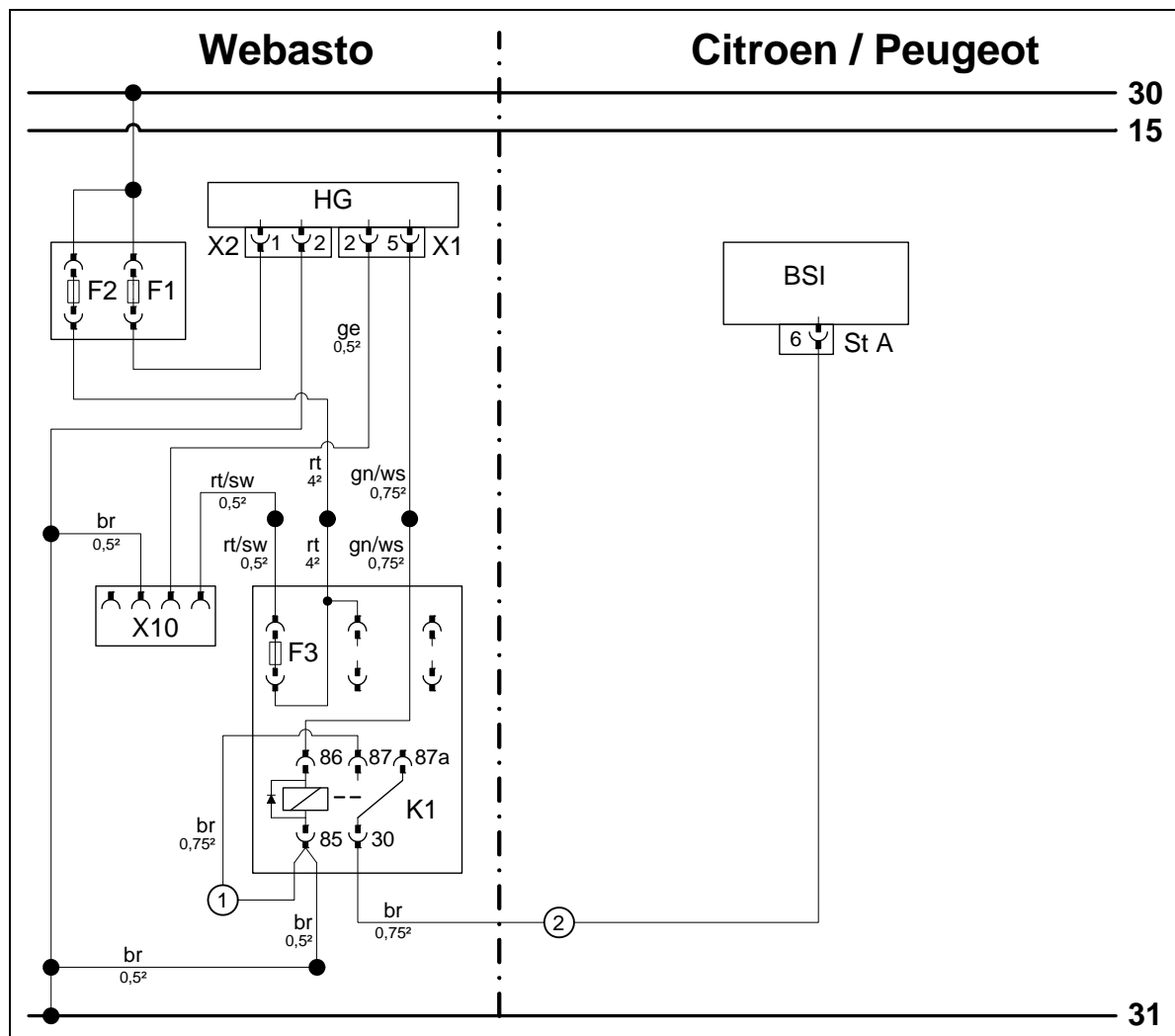

Wiring diagram

Webasto components		Vehicle components		Colours and symbols	
HG	TT-Evo heater	BSI	Central electrical box for passenger compartment	gn	green
X1	6-pin heater connector			ws	white
X2	2-pin heater connector	St A	20-pin connector BSI	rt	red
X10	4-pin connector of heater control			br	brown
K1	Fan relay			sw	black
F1	20A fuse			ge	yellow
F2	30A fuse			Cable and connector colours may vary.	
F3	1A fuse				

Legend

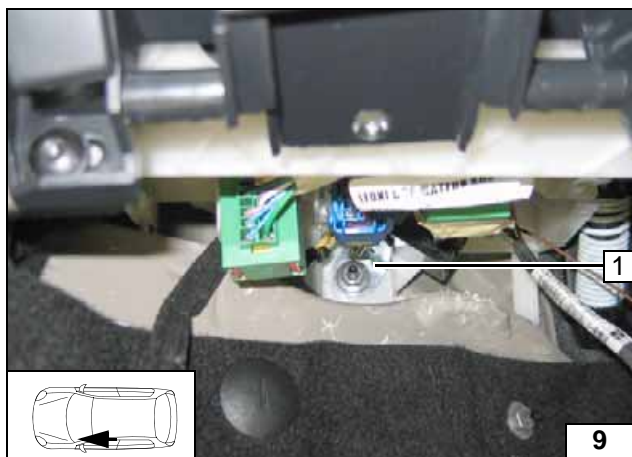

1 Angle bracket, original vehicle stud bolt, flanged nut

Installing fuse holder of passenger compartment

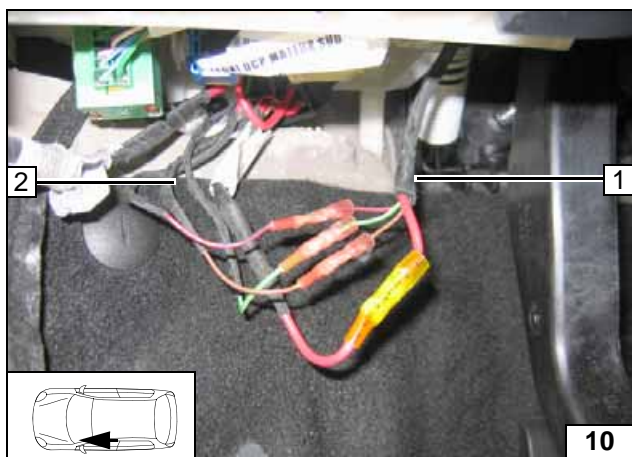

Connect wiring harness of heater 1 to wiring harness of passenger compartment fuse holder 2 according to wiring diagram, in such a way that the wires of the same colour are connected to each other.



Connecting wiring harnesses

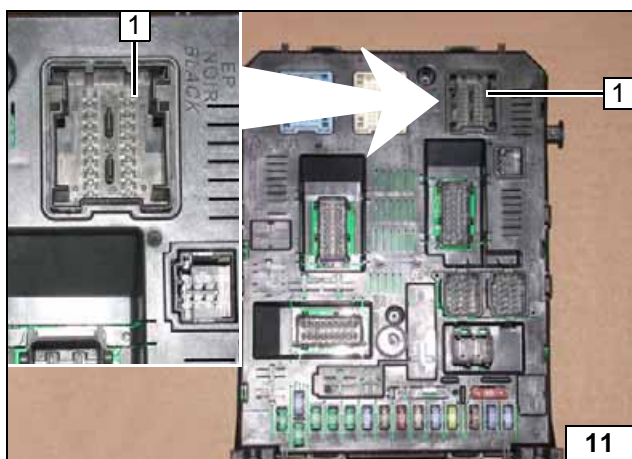

View of BSI.

1 Socket for 2-piece connector. 40-pin



Detaching BSI and routing downward

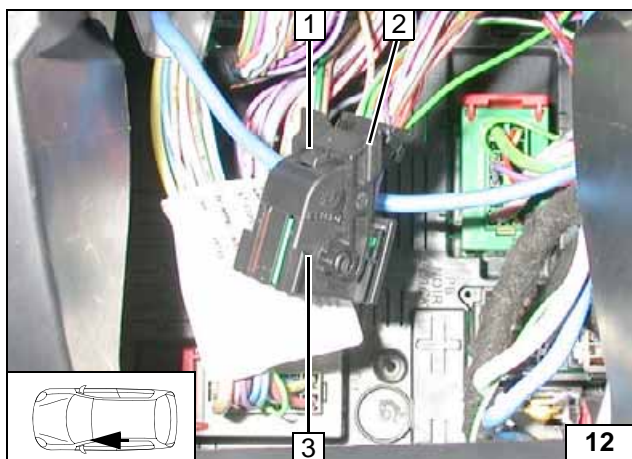

Illustration shows Citroen C5. Press in locking tab 1 and fold down bar 2.

3 2-piece connector



Pulling connector off BSI and removing

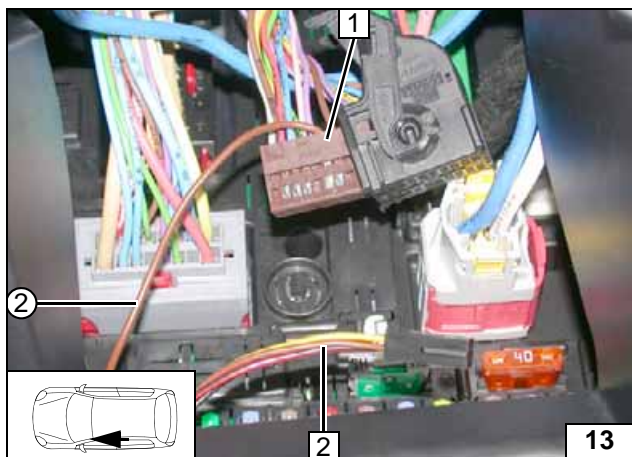

Illustration shows Citroen C5. Connection on 20-pin connector 1 from BSI (connector colour may vary). Insert microtimer from brown (br) wire 2 in PIN 6. Remove any existing wires on pin 6 and insulate. Route wiring harness of digital timer 2 upward to installation location of digital timer. Produce connections as shown in wiring diagram.

Connec-
tion of BSI

Digital Timer Option

Citroen C5

- 1 Digital timer

Installing
digital timer



Peugeot 407

- 1 Digital timer

Installing
digital timer



Remote option (Telestart)

Citroen C5

Mount connector (6-pin) from adapter wiring harness on receiver 2.

- 1 Double-sided adhesive tape



Installing
receiver

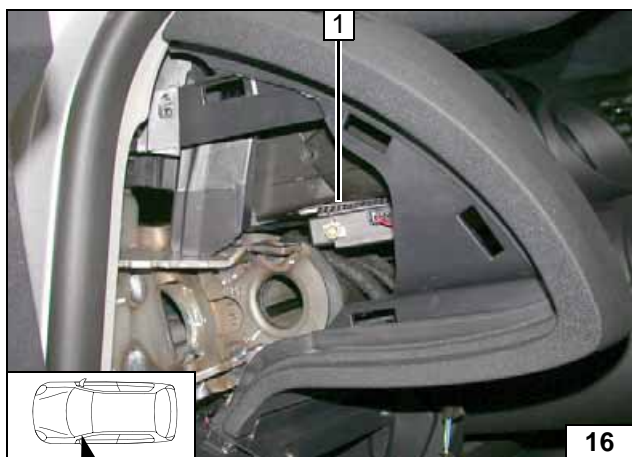

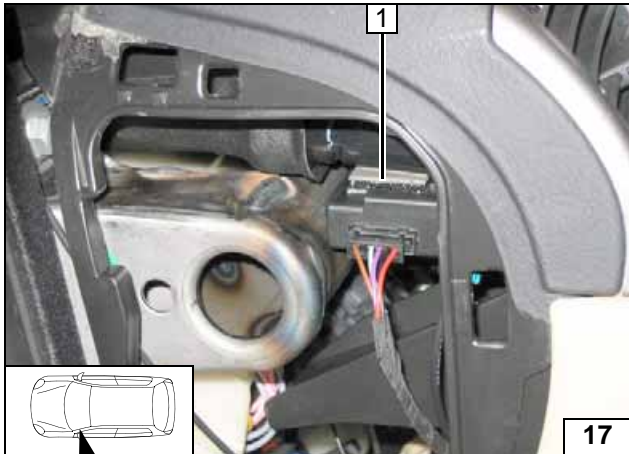
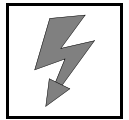

Peugeot 407

Mount connector (6-pin) from adapter wiring harness on receiver **2**.

- 1 Double-sided adhesive tape

Installing receiver

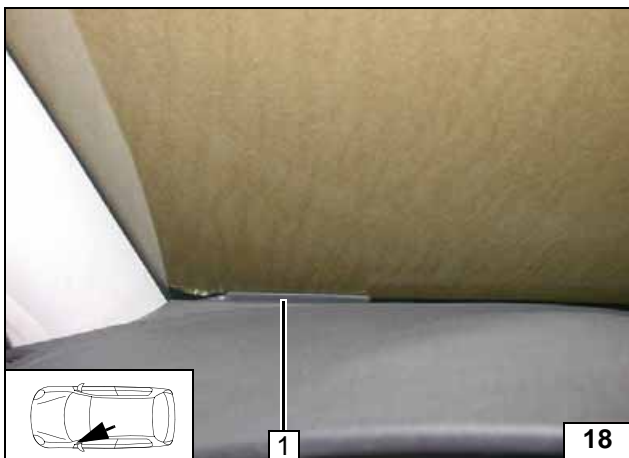

All vehicles

- 1 Antenna

Installing antenna

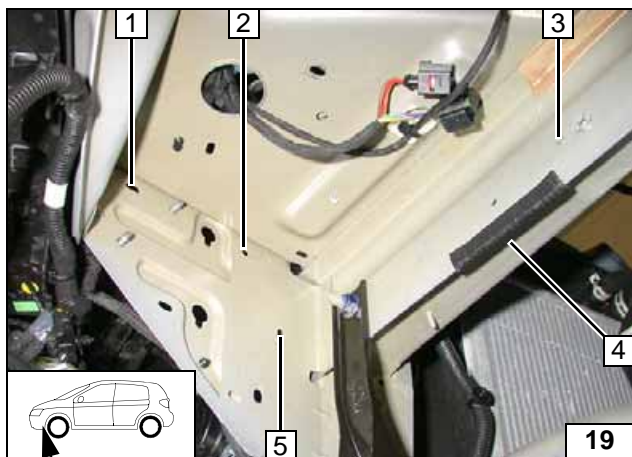

Preparing Installation Location



Move connector from position 2 (if present) to position 5.

- 1 Fastening point for heater (existing holes)
- 2 Fastening point for heater (existing holes)
- 3 Fastening point for heater (existing threaded hole or stud bolt)
- 4 100 mm edge protection

Copying hole pattern

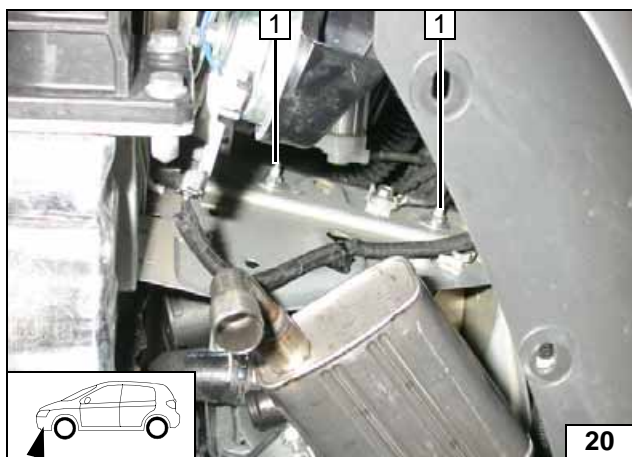

Installing Heater



Mount stud bolts from bracket in existing holes.

- 1 Stud bolt, large diameter washer, flanged nut [2x each]

Installing heater

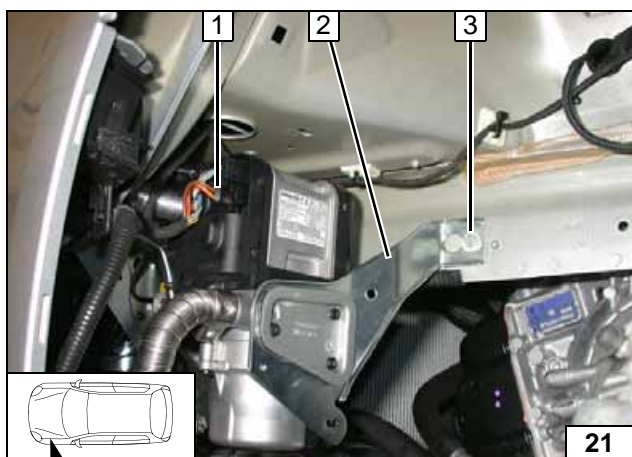

- 1 Mounting wiring harness of heater
- 2 Bracket of heater
- 3 M6x20 bolt, spring lockwasher, large diameter washer, threaded hole, or flanged nut on original vehicle stud bolt

Installing bracket





Coolant Circuit 1.8 / 2.0 B and 1.6 D

WARNING!

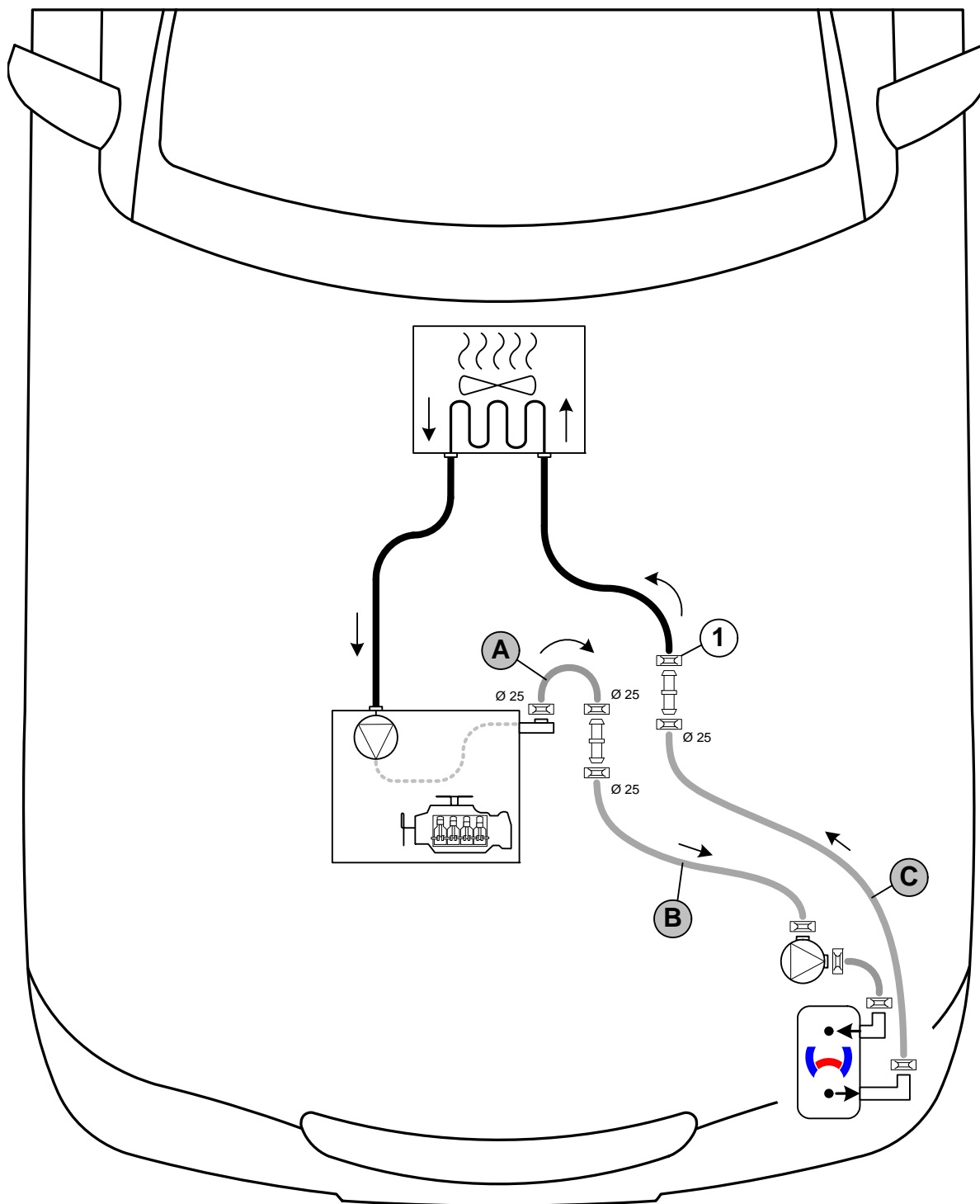
Any coolant running off should be collected in an appropriate container. Route hoses so that they are kink-free. Unless specified otherwise, always fasten using cable ties. Position clamps so that other hoses cannot be damaged. When installing the hoses, the heater must be filled with coolant. The connection should be "inline" based on the following diagram:



Hose routing diagram

1 = Original vehicle spring clip  . Connecting pipes without a specific designation  = 27mm dia. All connecting pipes  = 18x18 mm dia.



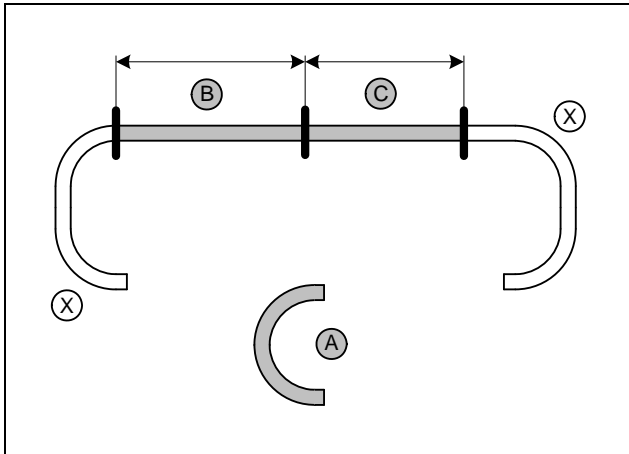

Discard section X.
Hose A = 180° elbow 18x18

1.8l / 2.0l petrol

B = 780
C = 630

1.6l Diesel

B = 650
C = 470



Cutting hoses to length

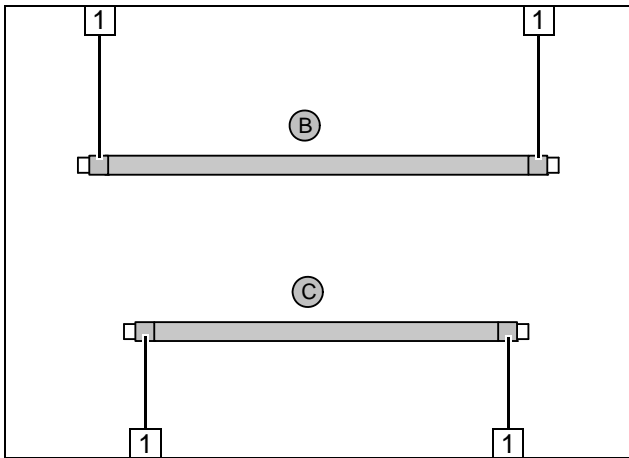

Push braided protection hoses onto hose B and C and cut to length.
Cut heat shrink plastic tubing to length.

- 1 50 mm long heat shrink plastic tubing [4x]



Preparing hoses

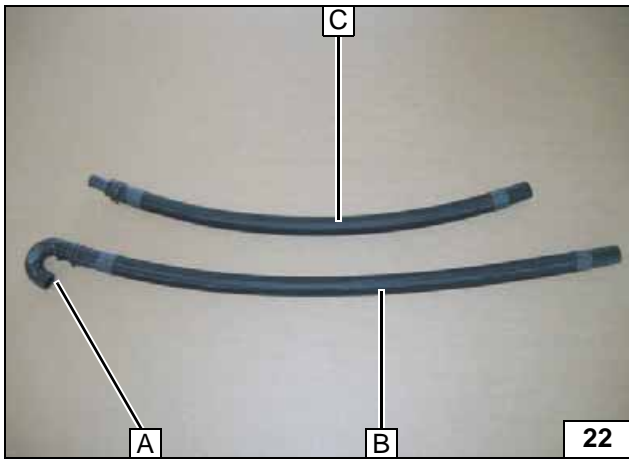

Premounting hoses

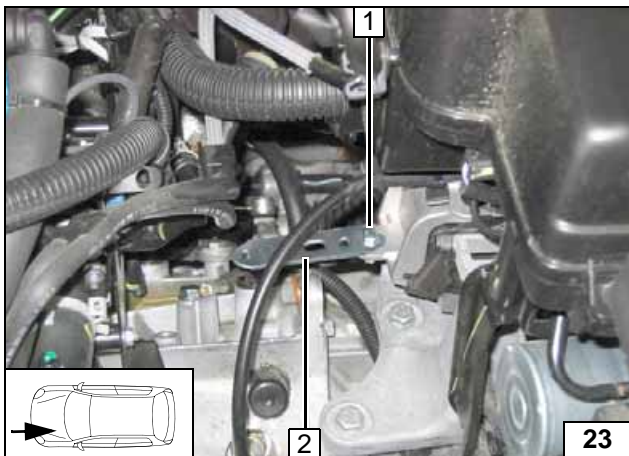

1.8l / 2.0l petrol

- 1 M6x20 bolt, engine mount, flanged nut
- 2 Perforated bracket

Installing perforated bracket

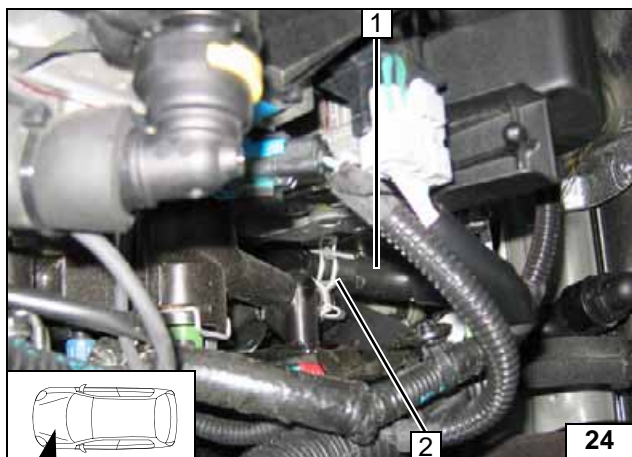

Disconnect hose 1 from engine outlet. Original vehicle spring clip 2 will be reused.

Cutting point

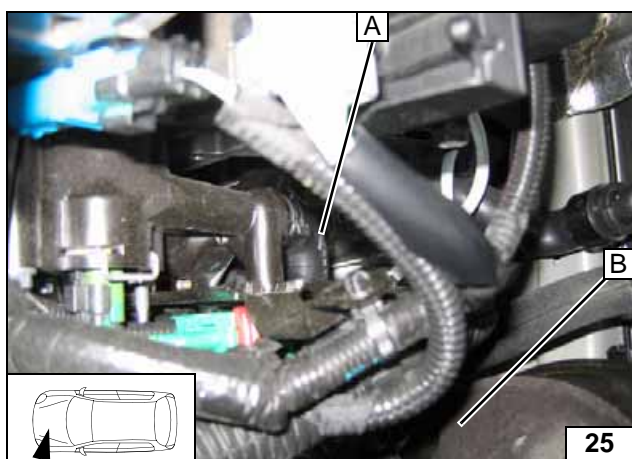

Connecting engine outlet

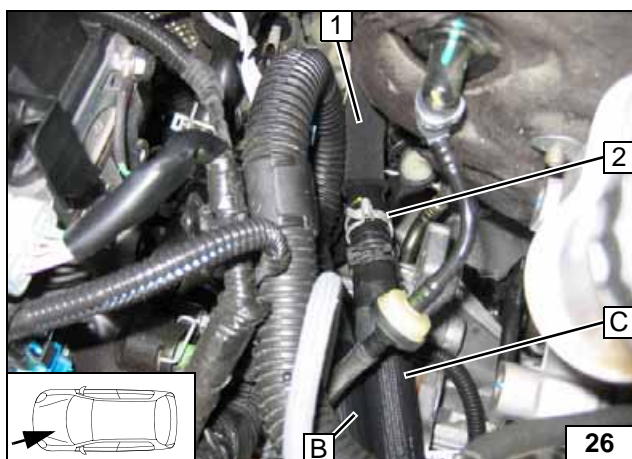

- 1 Hose of heat exchanger inlet
- 2 Original vehicle spring clip

Connecting heat exchanger inlet

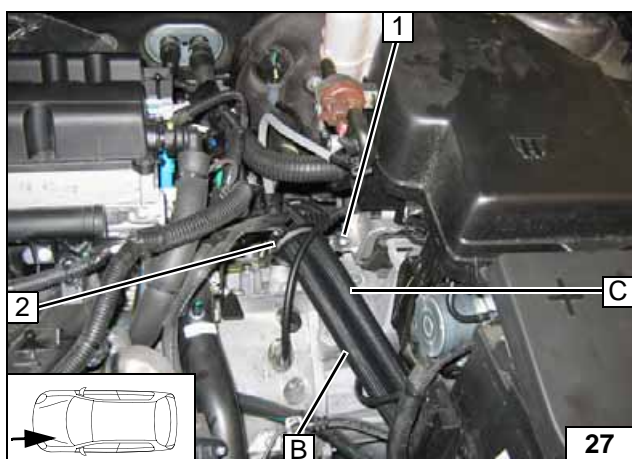

- 1 M6x20 bolt, flanged nut
- 2 48 mm dia. rubber-coated p-clamp

Routing in engine compartment

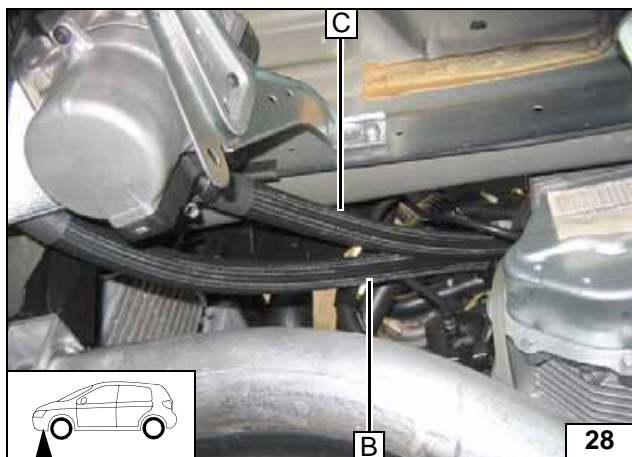
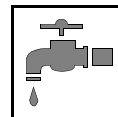

Routing in engine compartment

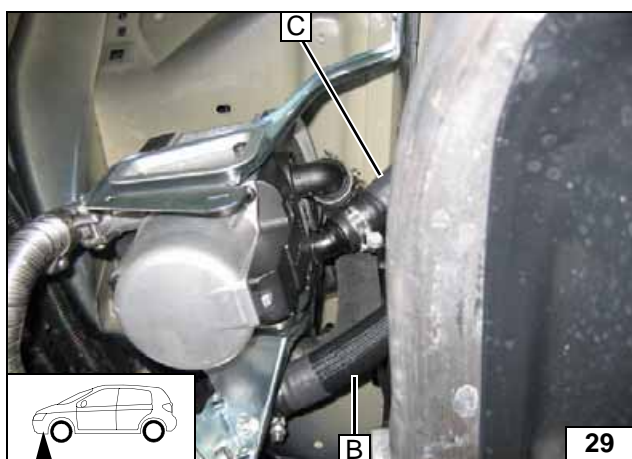

Ensure sufficient distance from neighbouring components.



Connecting heater



1.6l Diesel

Disconnect hose 1 from engine outlet. Original vehicle spring clip 2 will be reused.



Cutting point

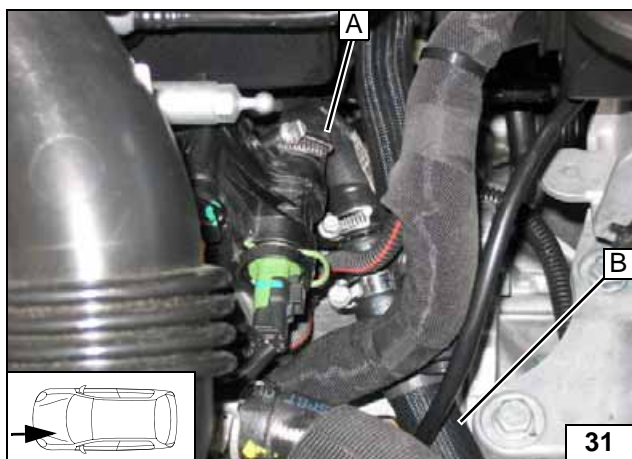

Connecting engine outlet

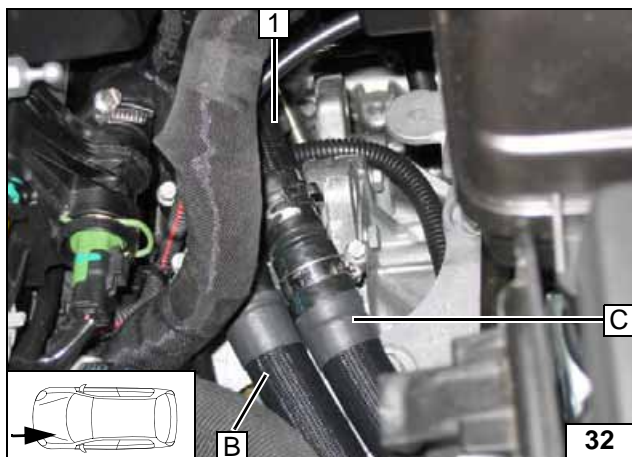

1 Hose of heat exchanger inlet

Connect-
ing heat ex-
changer
inlet

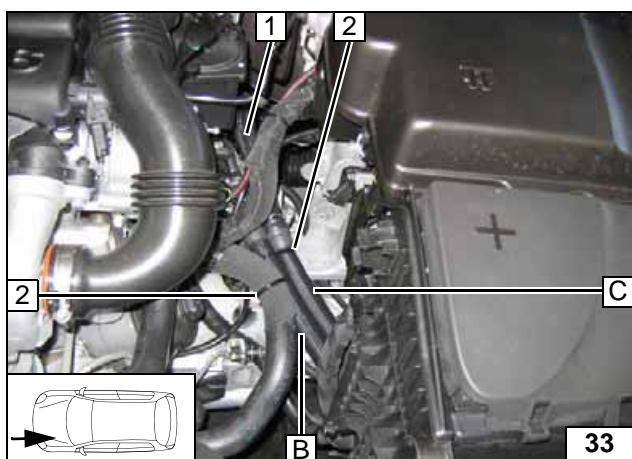

1 Hose section of heat exchanger inlet
2 Cable tie [2x]

Routing in
engine
compart-
ment

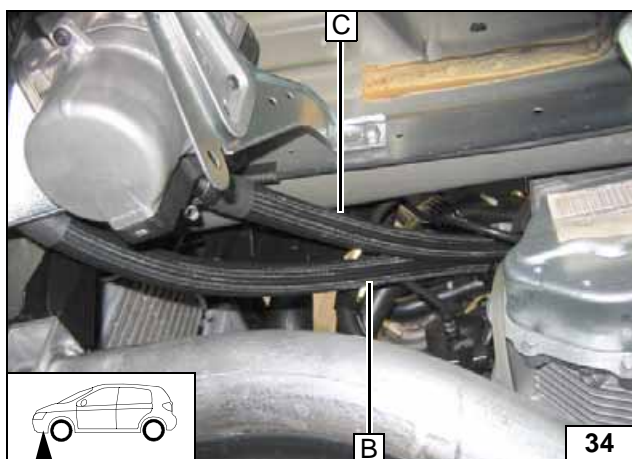

Routing in
engine
compart-
ment

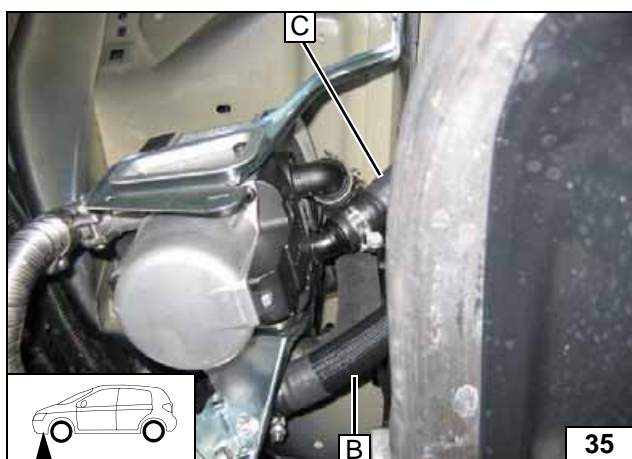

Ensure sufficient distance from neighbouring components.



Connect-
ing heater



Coolant Circuit 2.0 D RHR / RHF



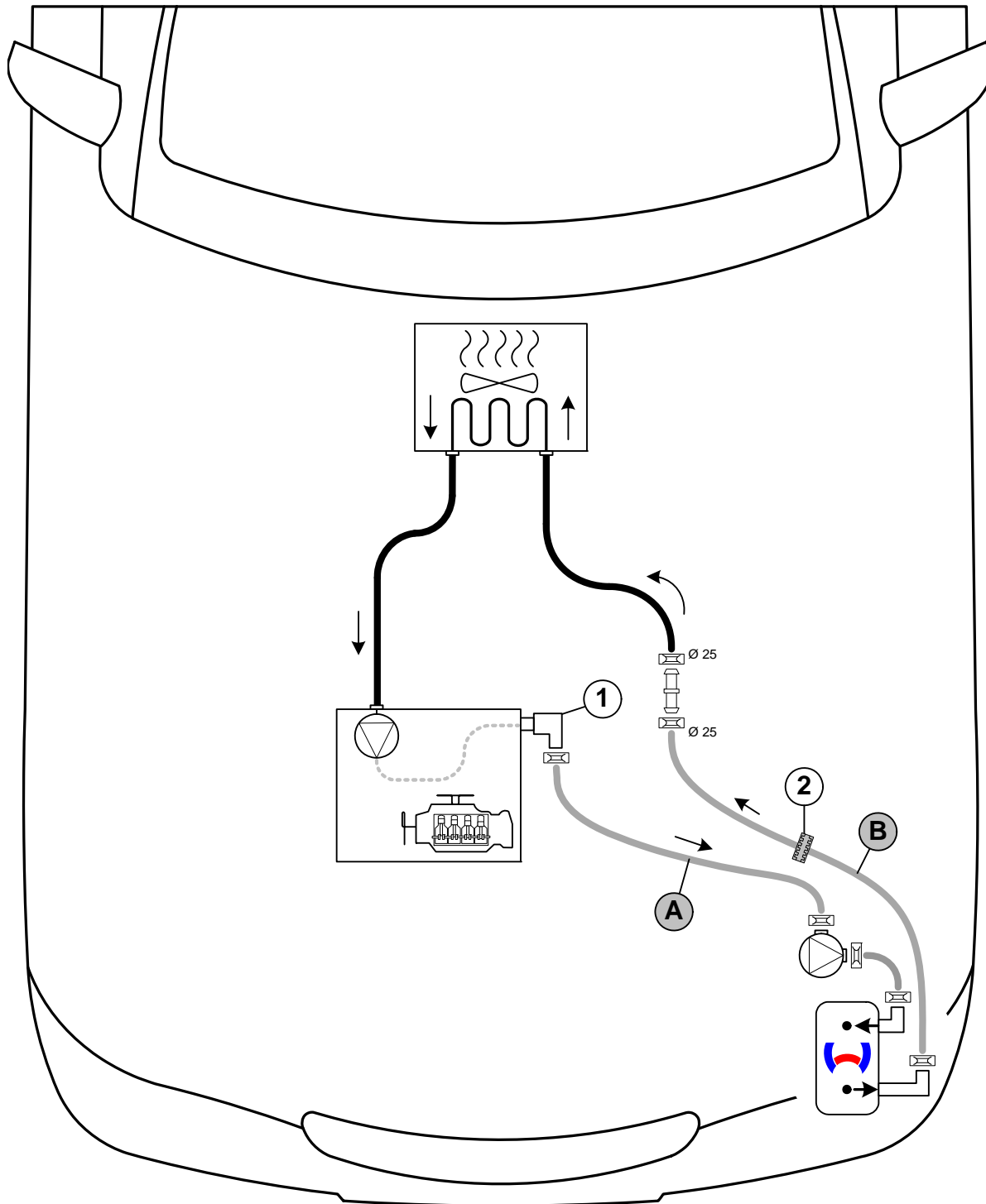

WARNING!

Any coolant running off should be collected in an appropriate container. Route hoses so that they are kink-free. Unless specified otherwise, always fasten using cable ties. Position clamps so that other hoses cannot be damaged. When installing the hoses, the heater must be filled with coolant. The connection should be "inline" based on the following diagram:



Hose routing diagram

All connecting pipes without a specific designation  = 27mm dia. **1** = Original vehicle coupling. Connecting pipe  = 18x18mm dia. **2** = Black (sw) rubber isolator  .



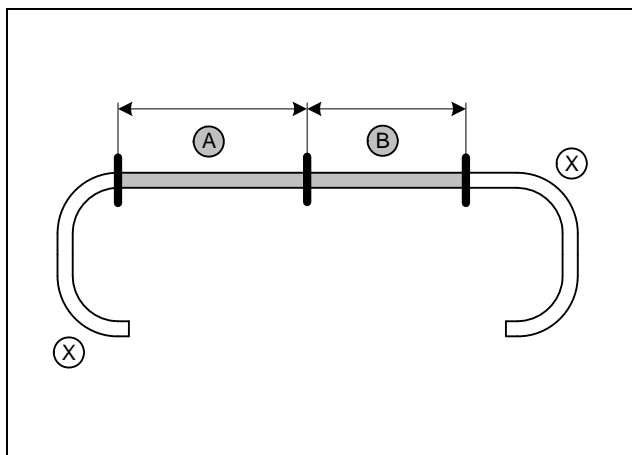

Discard section X

A = 740

B = 640



Cutting hoses to length

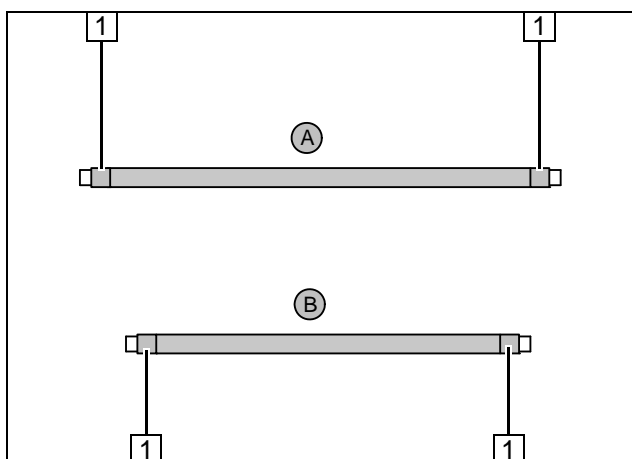

Push braided protection hoses onto hose A and B and cut to length.
Cut heat shrink plastic tubing to length.

- 1 50 mm long heat shrink plastic tubing [4x]



Preparing hoses

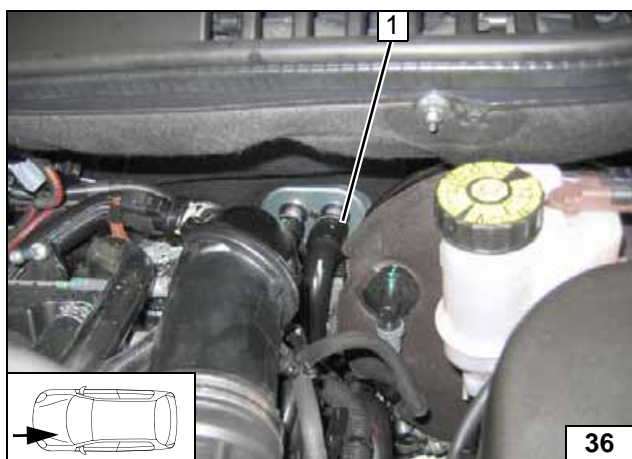

Remove original vehicle hose 1. Remove braided protective hose and discard.



Removing hose

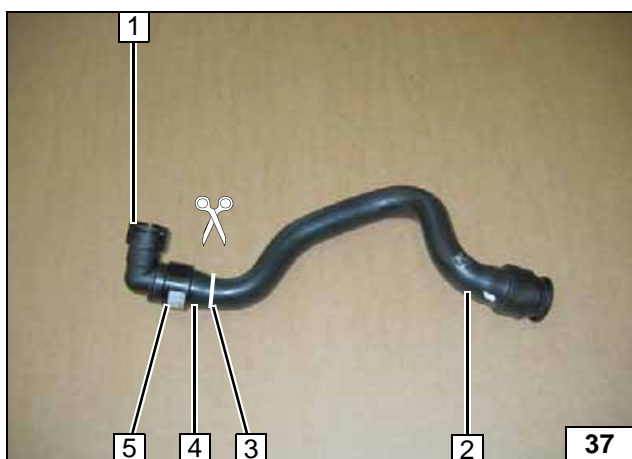

Cut open plastic clamp 5 and remove coupling of engine outlet 1. Discard plastic clamp and hose section 4. Twist coupling by 180° and mount on engine outlet.

- 2 Hose of heat exchanger inlet
- 3 Cutting point



Processing hose

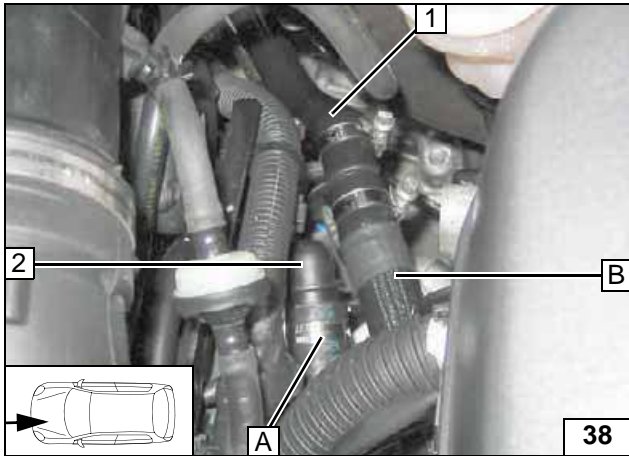

- 1 Hose section of heat exchanger inlet
- 2 Coupling on engine outlet twisted by 180°

Con-
nec-
tion of en-
gine out-
let and heat
exchanger
inlet

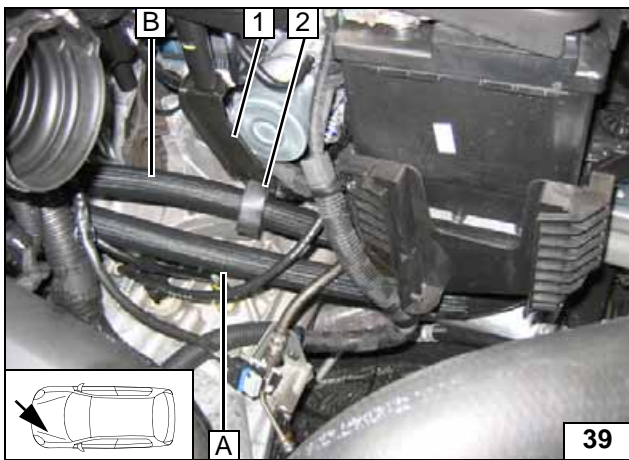

Fasten black (sw) rubber isolator 2 on strut 1 with cable tie.



Routing in
engine com-
part-
ment

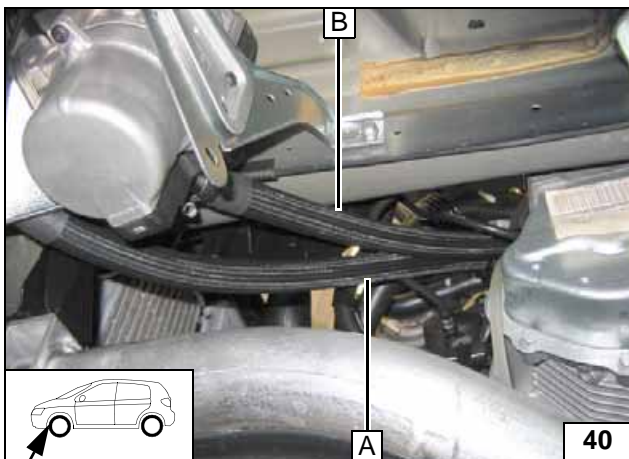

Routing in
engine com-
part-
ment

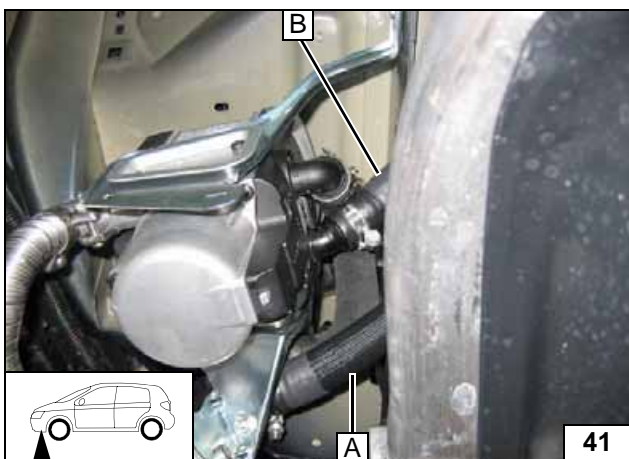

Ensure sufficient distance from neighbouring components.



Connect-
ing heater



Coolant Circuit 2.0 D RHH



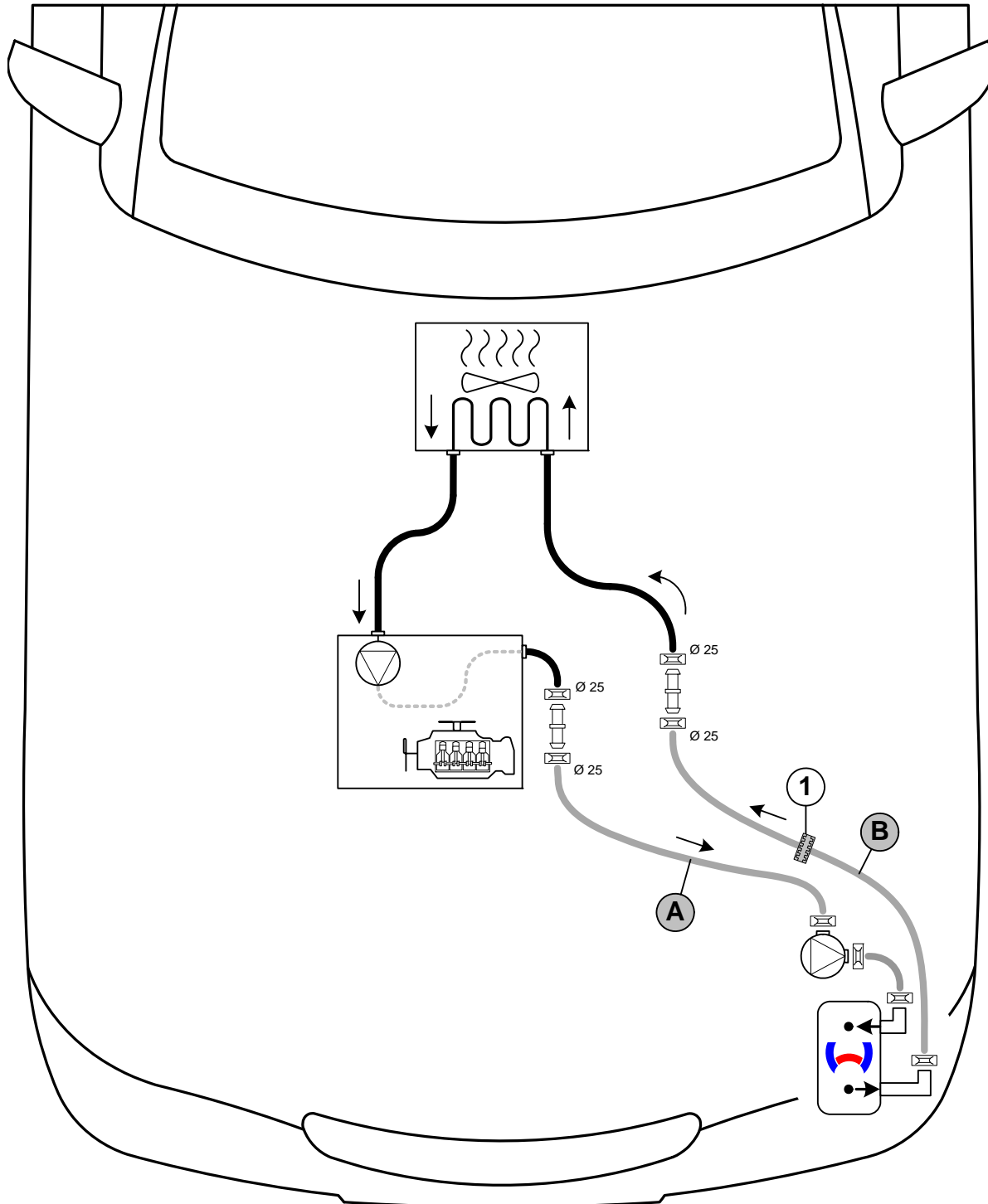

WARNING!

Any coolant running off should be collected in an appropriate container. Route hoses so that they are kink-free. Unless specified otherwise, always fasten using cable ties. Position clamps so that other hoses cannot be damaged. When installing the hoses, the heater must be filled with coolant. The connection should be "inline" based on the following diagram:



Hose routing diagram

All connecting pipes without a specific designation  = 27mm dia.
 All connecting pipes  = 18x18 mm dia. 1 = Black (sw) rubber isolator .



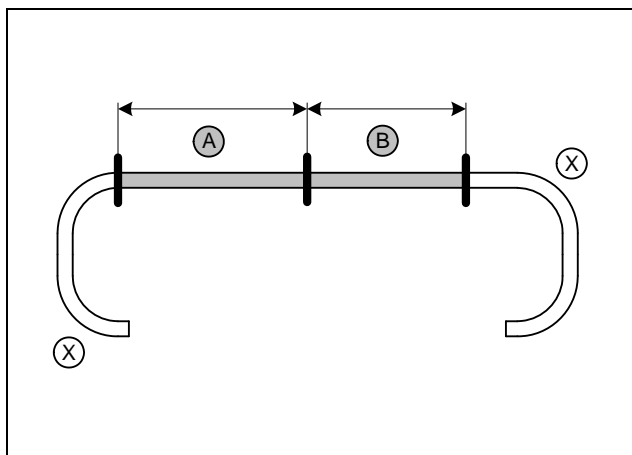

Discard section X

A = 610

B = 610



Cutting hoses to length

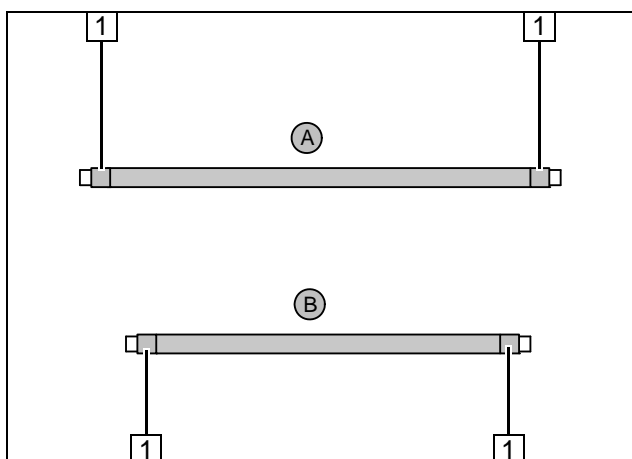

Push braided protection hoses onto hose A and B and cut to length.
Cut heat shrink plastic tubing to length.

- 1 50 mm long heat shrink plastic tubing [4x]



Preparing hoses

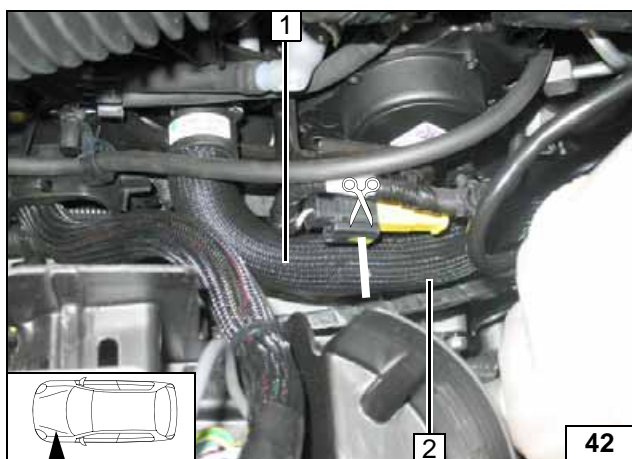

- 1 Hose section of engine outlet
- 2 Hose section of heat exchanger inlet

Cutting point

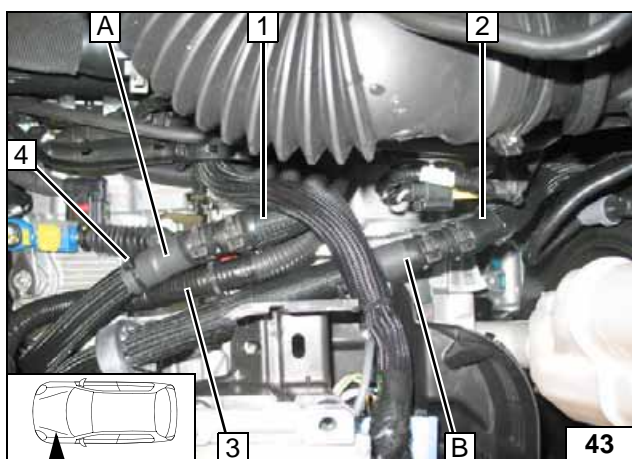

Figure shows an automatic transmission.
Coupling of engine outlet 1 twisted forward by 180° on the connection piece.

- 2 Hose of heat exchanger inlet
- 3 Original vehicle wiring harness
- 4 Cable tie



Connection of engine outlet and heat exchanger inlet

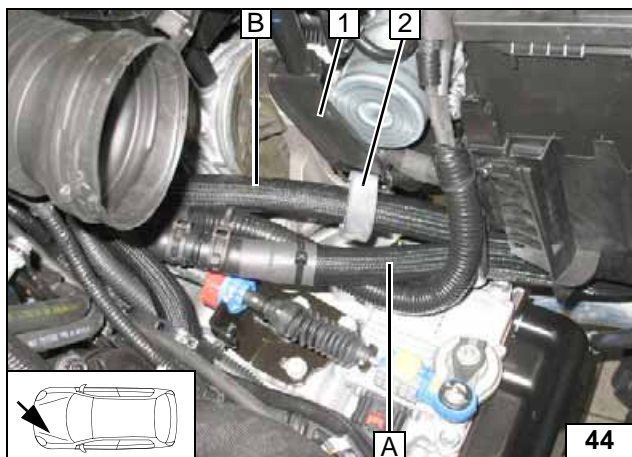

Figure shows an automatic transmission. Fasten black (sw) rubber isolator 2 on strut 1 with cable tie.



Routing in engine compartment

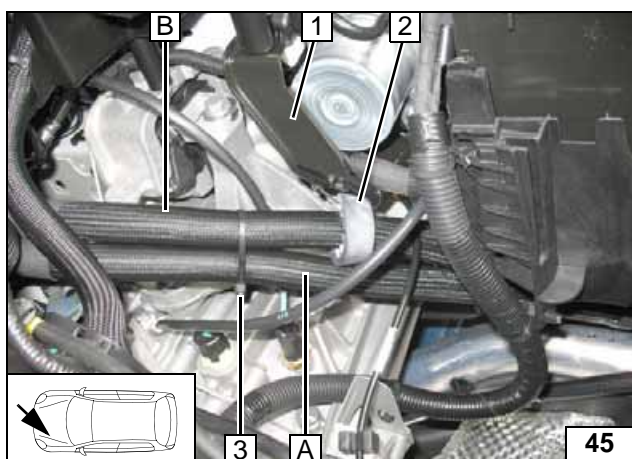
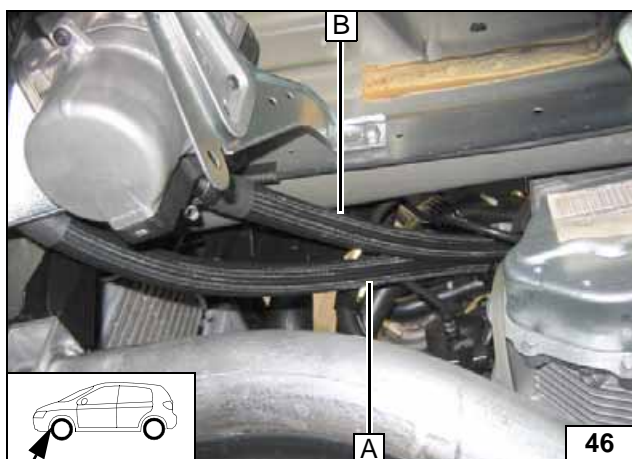

Figure shows a manual transmission. Fasten black (sw) rubber isolator 2 on strut 1 with cable tie.



Routing in engine compartment

3 Cable tie



Routing in engine compartment

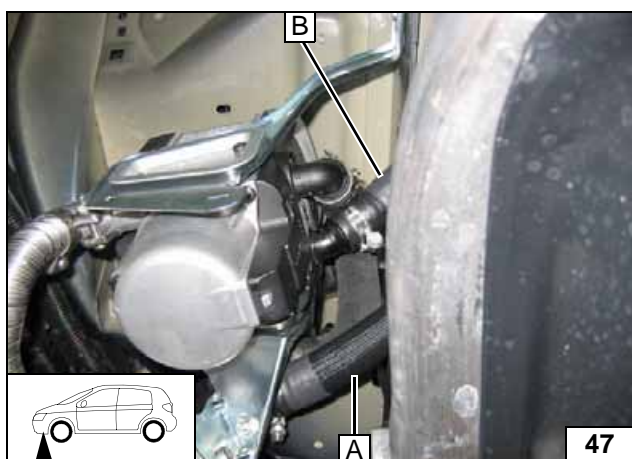

Ensure sufficient distance from neighbouring components.



Connecting heater

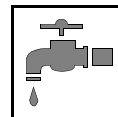



Coolant Circuit 1.6 B and 2.2 D

WARNING!

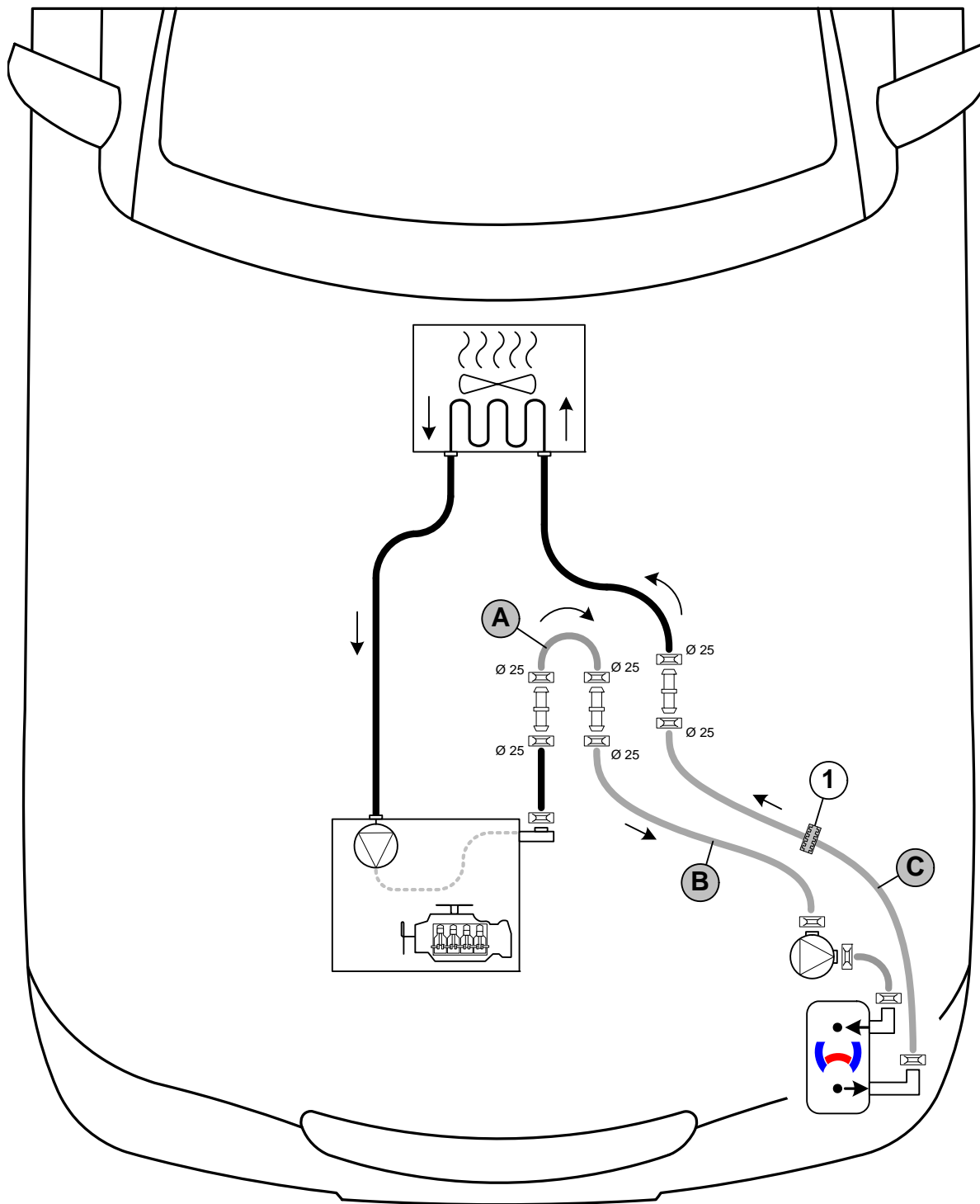
Any coolant running off should be collected in an appropriate container. Route hoses so that they are kink-free. Unless specified otherwise, always fasten using cable ties. Position clamps so that other hoses cannot be damaged. When installing the hoses, the heater must be filled with coolant. The connection should be "inline" based on the following diagram:



Hose routing diagram

All connecting pipes without a specific designation  = 27mm dia.
 All connecting pipes  = 18x18 mm dia. 1 = Black (sw) rubber isolator  (2.2 liter diesel only).



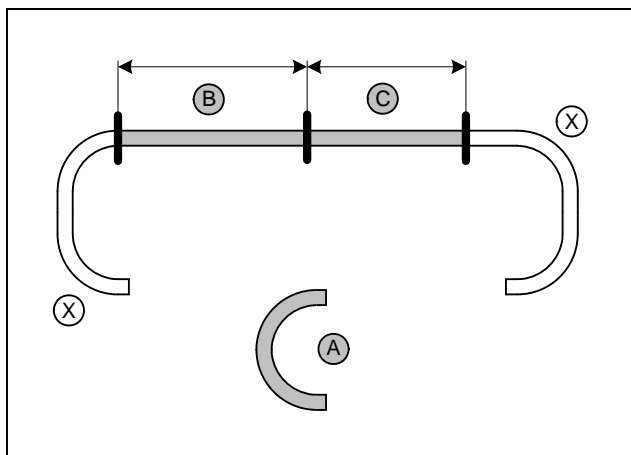

Discard section **X**.
Hose **A** = 180° elbow

1.6l Petrol

B = 890
C = 800

2.2l Diesel

B = 750
C = 630



Cutting hoses to length

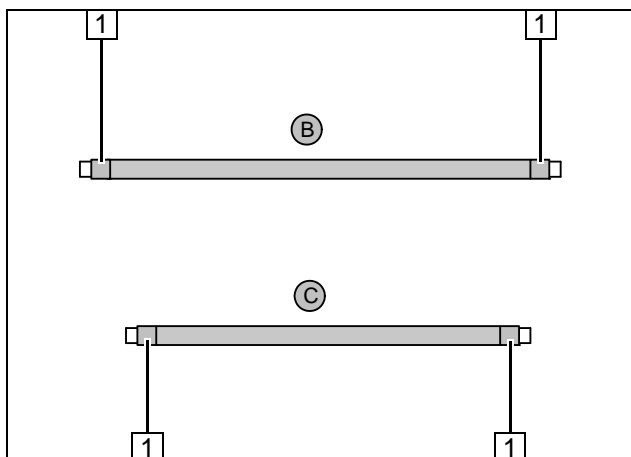

Push braided protection hoses onto hose **B** and **C** and cut to length.
Cut heat shrink plastic tubing to length.

- 1 50 mm long heat shrink plastic tubing [4x]



Preparing hoses

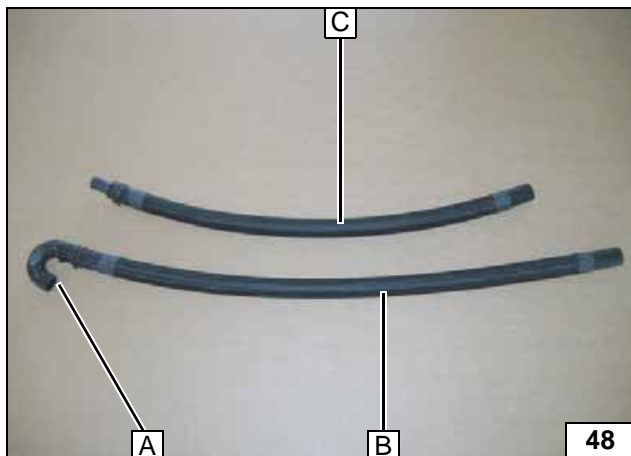

Premounting hoses

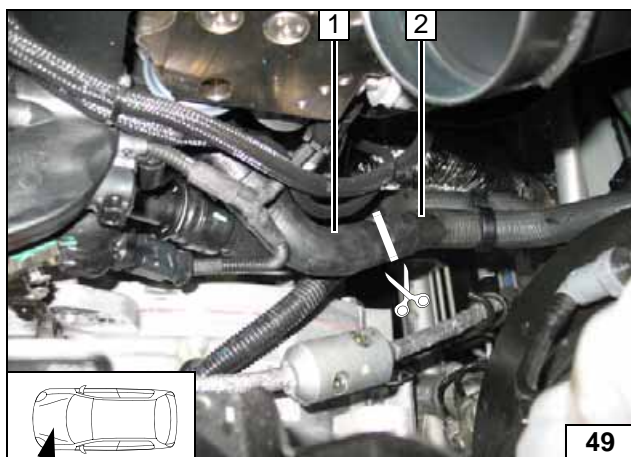

1.6l Petrol

Cut off original vehicle hose on engine outlet/heat exchanger inlet at marking.

- 1 Hose section of engine outlet
- 2 Hose section of heat exchanger inlet



Cutting point

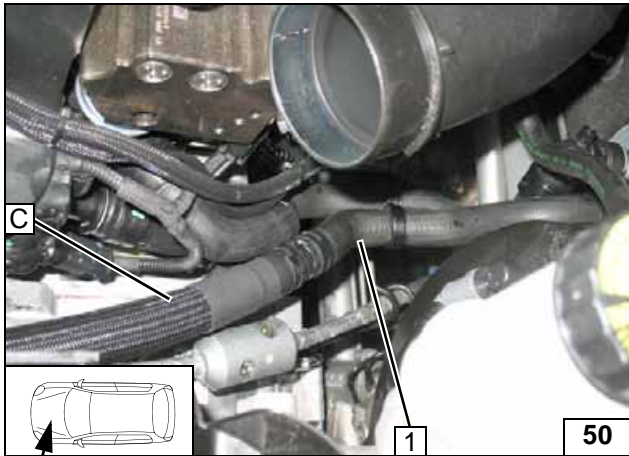

1 Hose of heat exchanger inlet

Connect-
ing heat ex-
changer
inlet

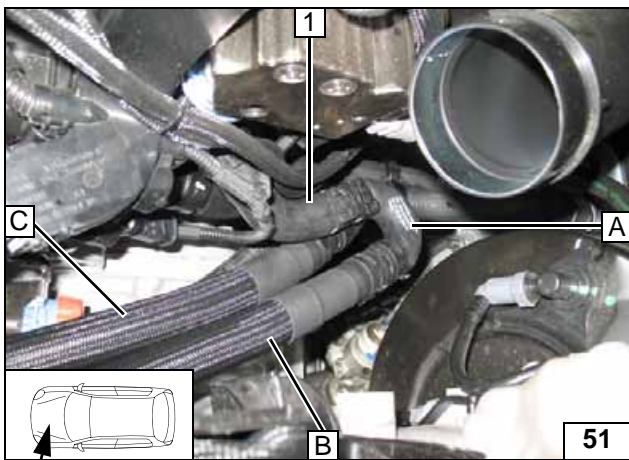

1 Hose of engine outlet

Connect-
ing engine
outlet

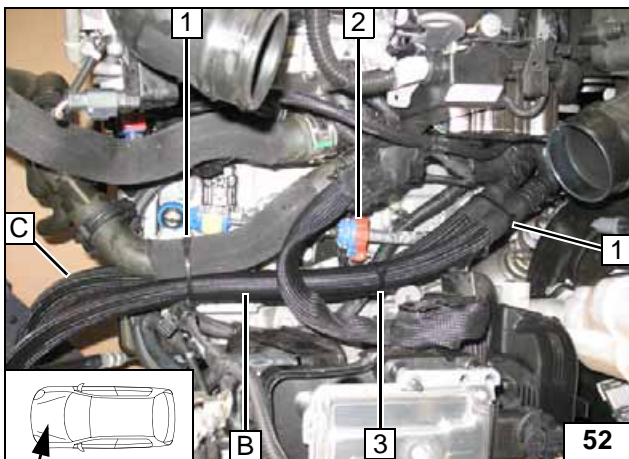

Attach cable tie on position **3** on actuating cable bracket and hose **B** and **C** .



- 1 Cable tie [2x]
- 2 Bracket of actuating cable

Routing in
engine
compartment

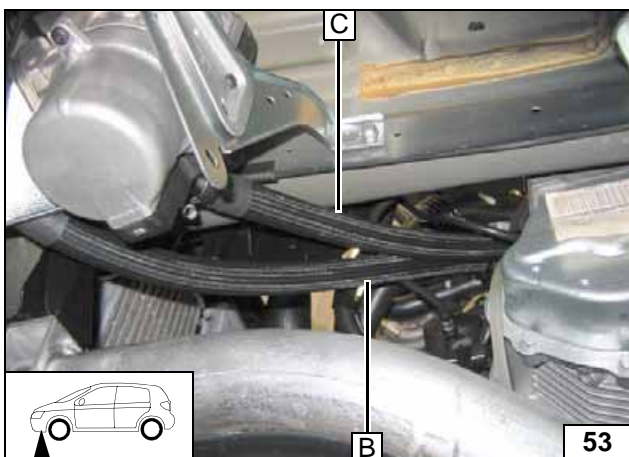

Routing in
engine
compartment

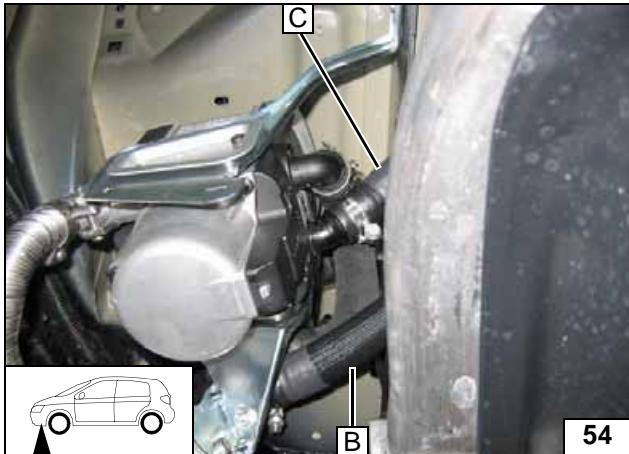

Ensure sufficient distance from neighbouring components.



**Connect-
ing heater**

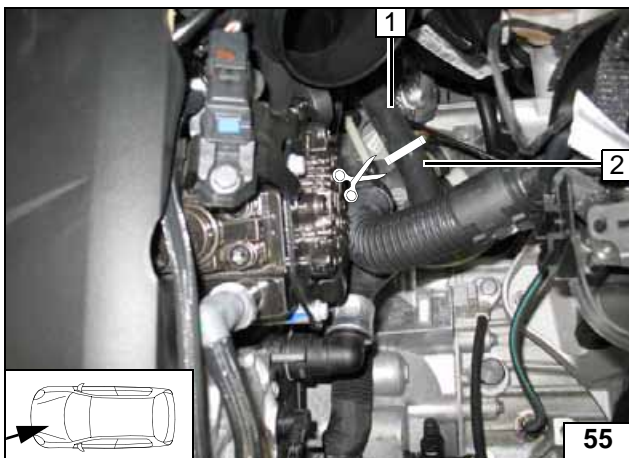

2.2l Diesel

Cut off original vehicle hose on engine outlet/heat exchanger inlet at marking.

- 1 Hose section of heat exchanger inlet
- 2 Hose section of engine outlet



**Cutting
point**

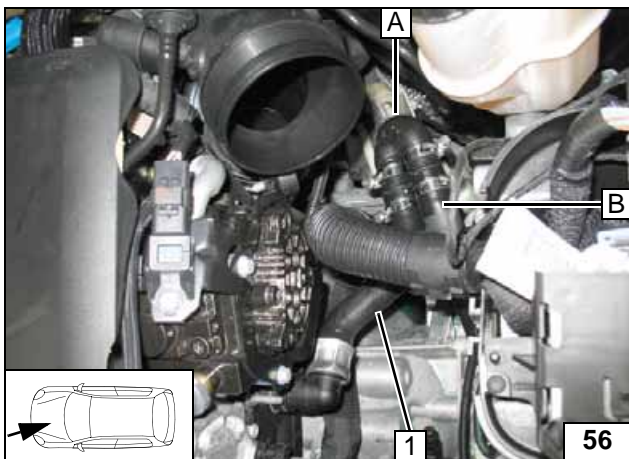

- 1 Hose of engine outlet

**Connect-
ing engine
outlet**

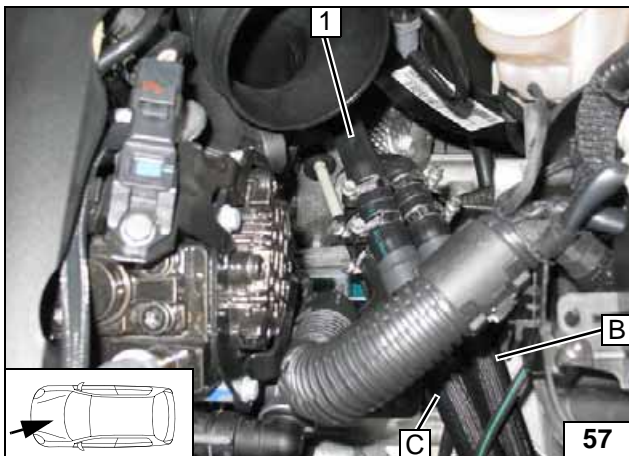

- 1 Hose of heat exchanger inlet

**Connect-
ing heat ex-
changer
inlet**

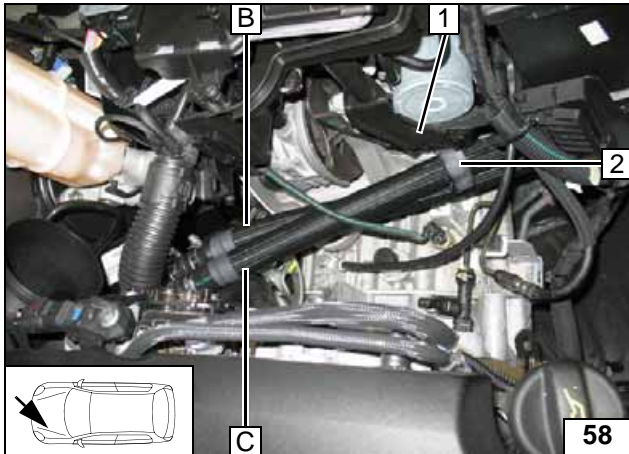

Fasten black (sw) rubber isolator 2 on strut 1 with cable tie.



Routing in engine compartment

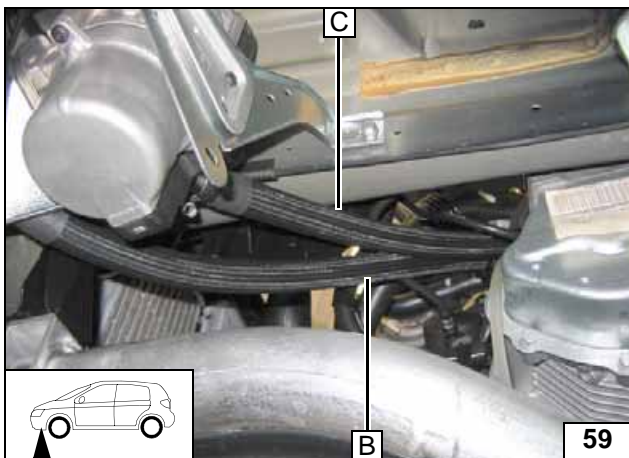

Routing in engine compartment

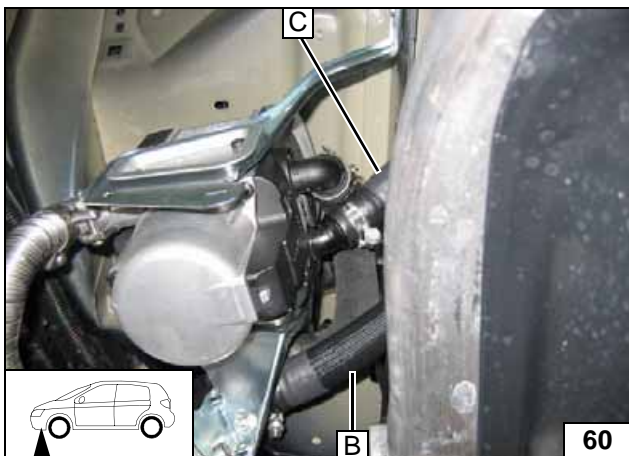

Ensure sufficient distance from neighbouring components.



Connecting heater

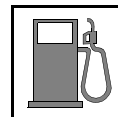

Fuel

CAUTION!

Open the vehicle's fuel tank cap, ventilate the tank and then re-close the tank lock.

Catch any fuel running off in an appropriate container.

Install fuel line and metering pump wiring harness so that they are protected against stone impact. Unless specified otherwise, always fasten using cable ties.

Mount the fuel line and wiring harness with rub protection on sharp edges.

WARNING!

The fuel line and wiring harness are routed to the metering pump as shown in the wiring harness routing diagram.

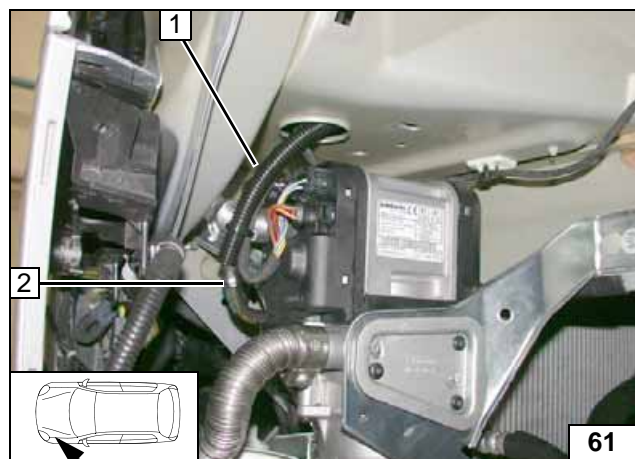

- 1 Fuel line and wiring harness of metering pump in corrugated tube
- 2 10mm dia. Caillau clamp, 90° moulded hose

Connect-
ing heater

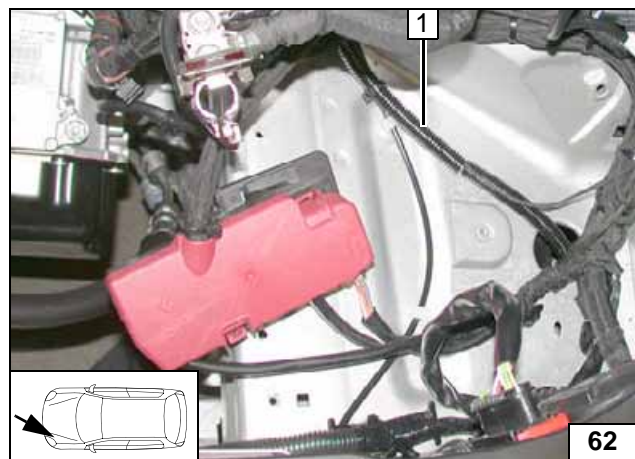

- 1 Fuel line and wiring harness of metering pump in corrugated tube

Routing
wire

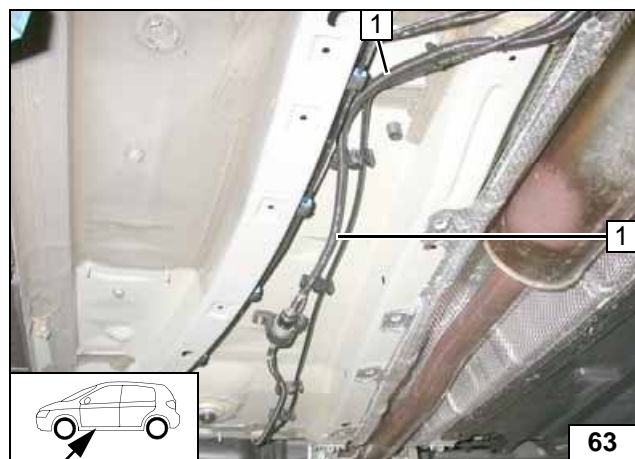

Petrol

- 1 Fuel line and wiring harness of metering pump in corrugated tube

Routing
wire

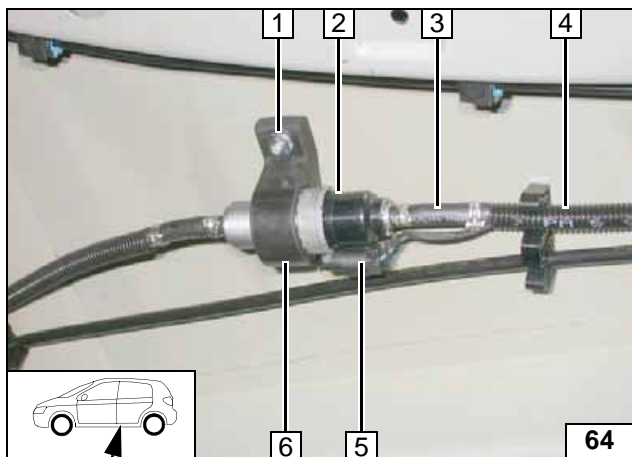
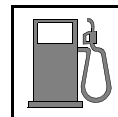

- 1 Flanged nut on original vehicle stud bolt
- 2 Metering pump
- 3 Hose section, 10mm dia. Caillau clamp [2x]
- 4 Fuel line and wiring harness of metering pump in corrugated tube
- 5 Wiring harness of metering pump, connector mounted
- 6 Bracket of metering pump



Mounting metering pump

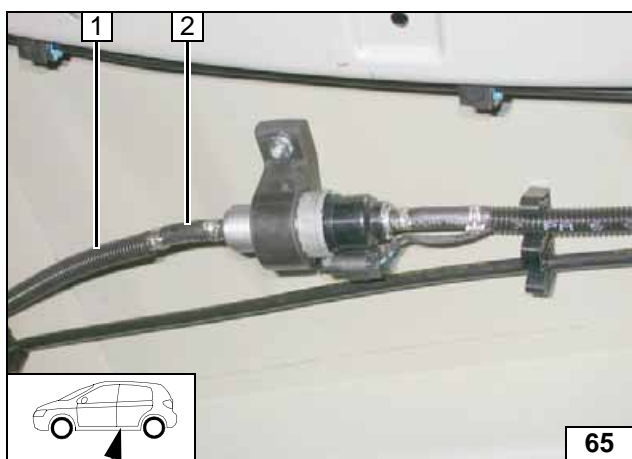

- 1 Fuel line in corrugated tube
- 2 Hose section, 10mm dia. Caillau clamp [2x]

Connecting metering pump

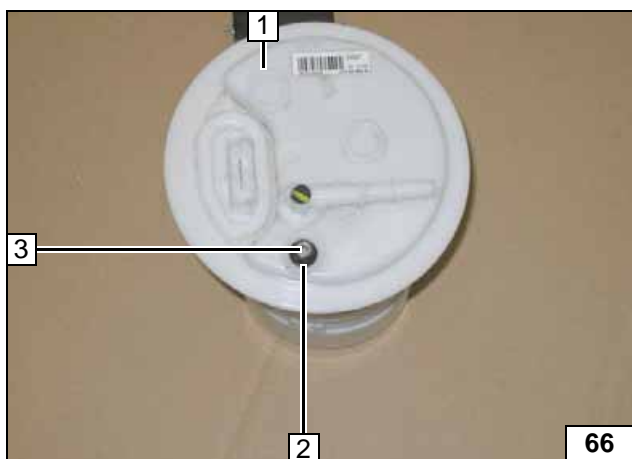

Remove fuel-tank sending unit 1 in accordance with the manufacturer's instructions.

- 2 Flanged nut
- 3 Copy hole pattern, 6mm dia. hole



Fuel extraction



Cut fuel standpipe 1 to length according to template.



Installing fuel stand-pipe

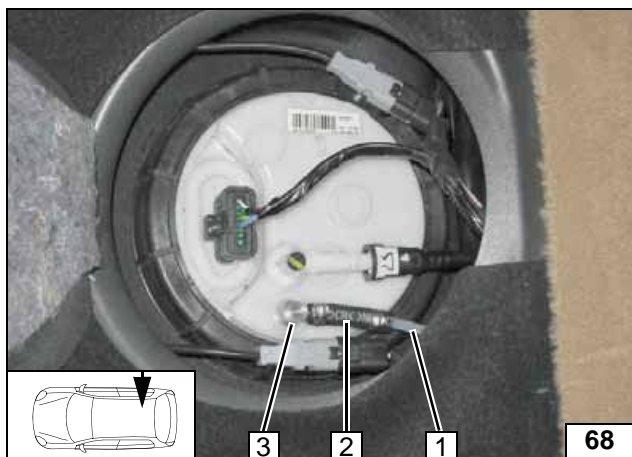
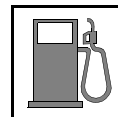

Check the position of the components; adjust if necessary. Check that they have freedom of movement.

Install fuel-tank sending unit according to manufacturer's instructions.

- 1 Fuel line
- 2 Hose section, 10mm dia. Caillau clamp [2x]
- 3 Fuel standpipe



**Connect-
ing fuel line**

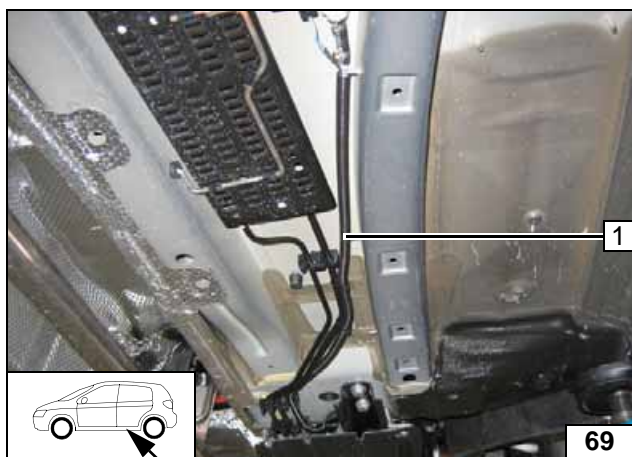

Diesel

- 1 Fuel line and wiring harness of metering pump in corrugated tube

**Routing
lines**

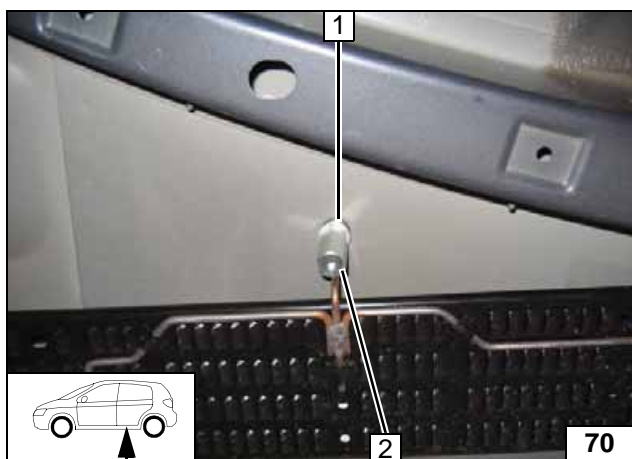

Remove original vehicle nut at position 1 and discard.

- 2 Large diameter washer, 30mm spacer nut



**Mounting
metering
pump**

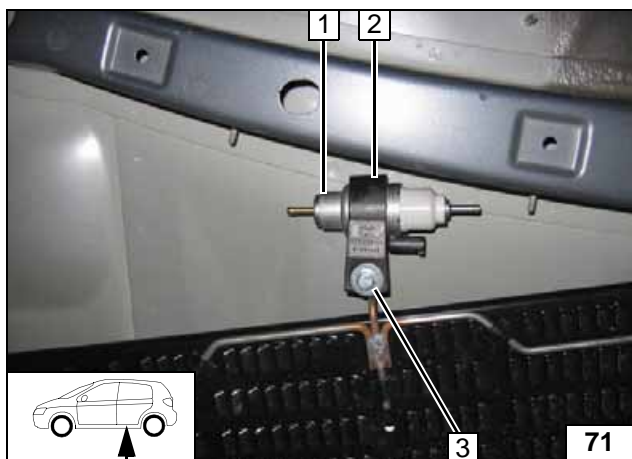

- 1 Metering pump
- 2 Bracket of metering pump
- 3 M6x25 bolt, large diameter washer



**Mounting
metering
pump**

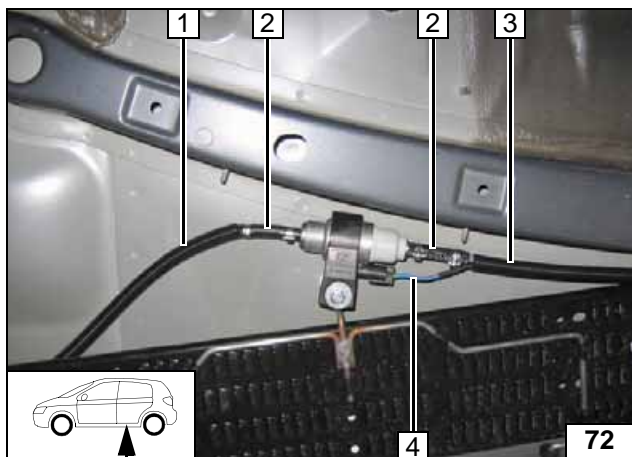

- 1 Fuel line in corrugated tube
- 2 Hose section [2x], 10mm dia. Caillau clamp [4x]
- 3 Fuel line and wiring harness of metering pump in corrugated tube
- 4 Wiring harness of metering pump, connector mounted

**Connect-
ing meter-
ing pump**

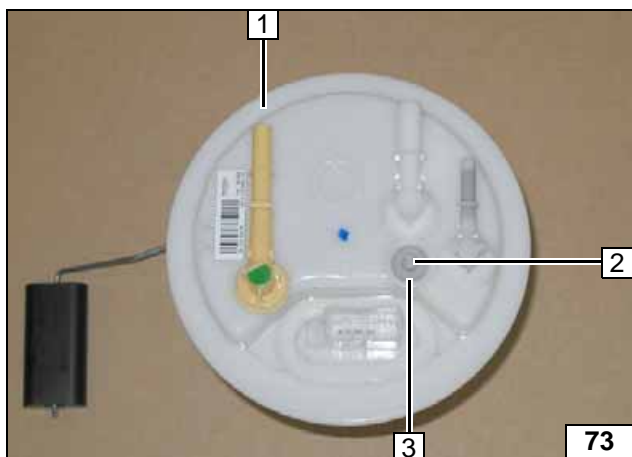

Remove fuel-tank sending unit 1 in accordance with the manufacturer's instructions.

- 2 Copy hole pattern, 6mm dia. hole
- 3 5mm dia. large diameter washer



**Fuel ex-
traction**

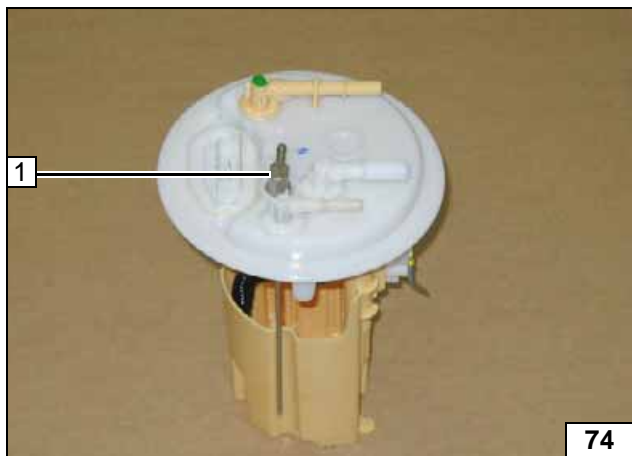

Shape fuel standpipe 1 as shown in the template and cut it to length.



**Installing
fuel stand-
pipe**

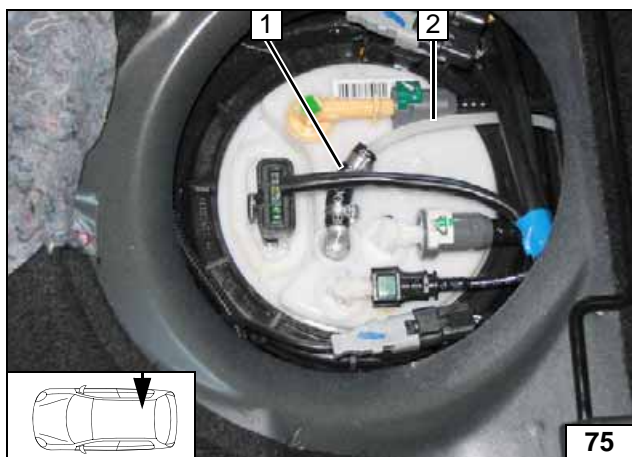

Check the position of the components; adjust if necessary. Check that they have freedom of movement. Install fuel-tank sending unit according to manufacturer's instructions.

- 1 Hose section, 10mm dia. Caillau clamp [2x]
- 2 Fuel line



**Connect-
ing fuel line**

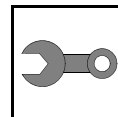

Final Work

WARNING!

Mount removed parts in reverse order. Check all hoses, clamps and all electrical connections for firm seating. Insulate all loose wires and tie back.
Only use manufacturer-approved coolant. Spray the heater components with anti-corrosion wax (Tectyl 100K, Order No. 111329).



- **Connect the battery.**
- **Fill and bleed the coolant circuit according to the vehicle manufacturer's specifications.**
- **Adjust digital timer, teach telestart transmitter.**
- **Code BSI to "external heater (parking heater)" according to manufacturer's instructions.**
- **Place the "Switch off parking heater before refuelling" signboard in the area of the filler neck.**
- **For initial startup and function check, please see installation instructions.**

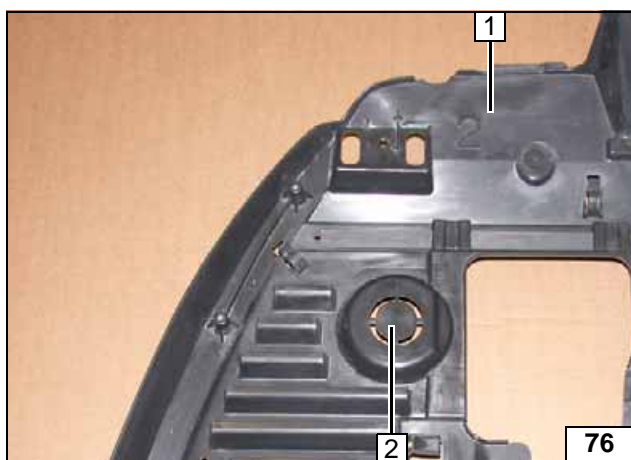

- 1 Underride protection
- 2 Cut out exhaust outlet along perforation

**Cutting out
underride
protection**

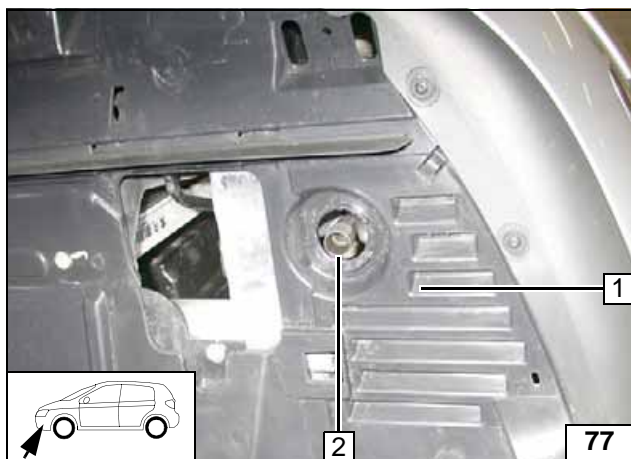

Mount underride protection 1 (exhaust end section centred in cut-out).

- 2 Exhaust end section



**Mounting
underride
protection**

Webasto Thermo & Comfort SE
Postfach 1410
82199 Gilching
Germany
Internet: www.webasto.com
Technical Extranet:
<http://dealers.webasto.com>

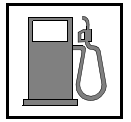

Template for Petrol Fuel Standpipe

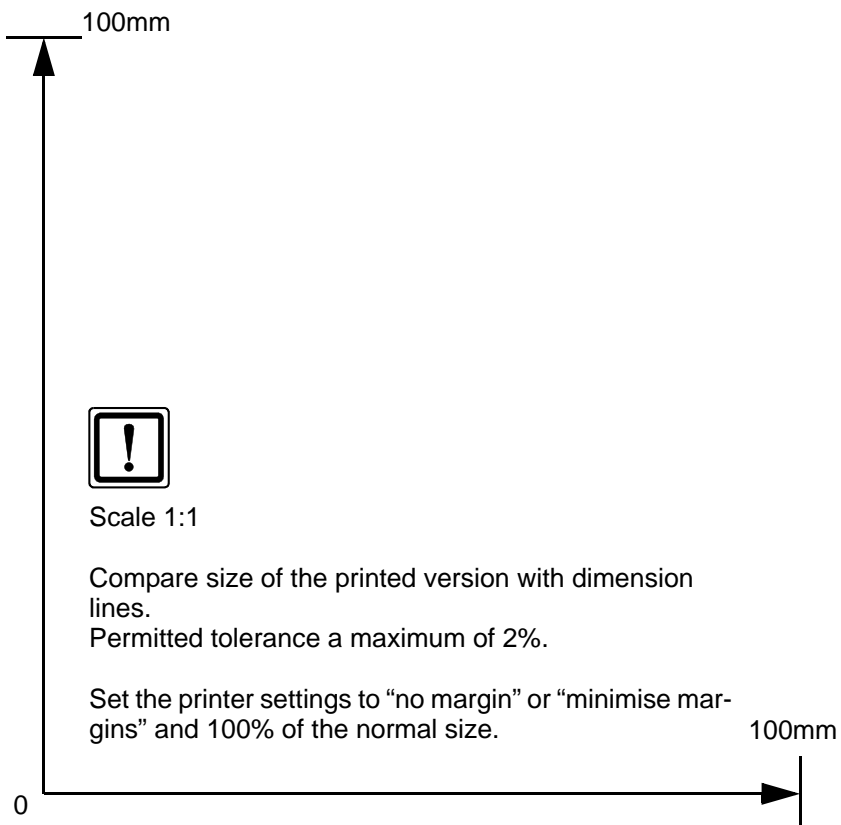

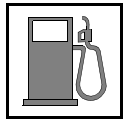

Template for Diesel Fuel Standpipe

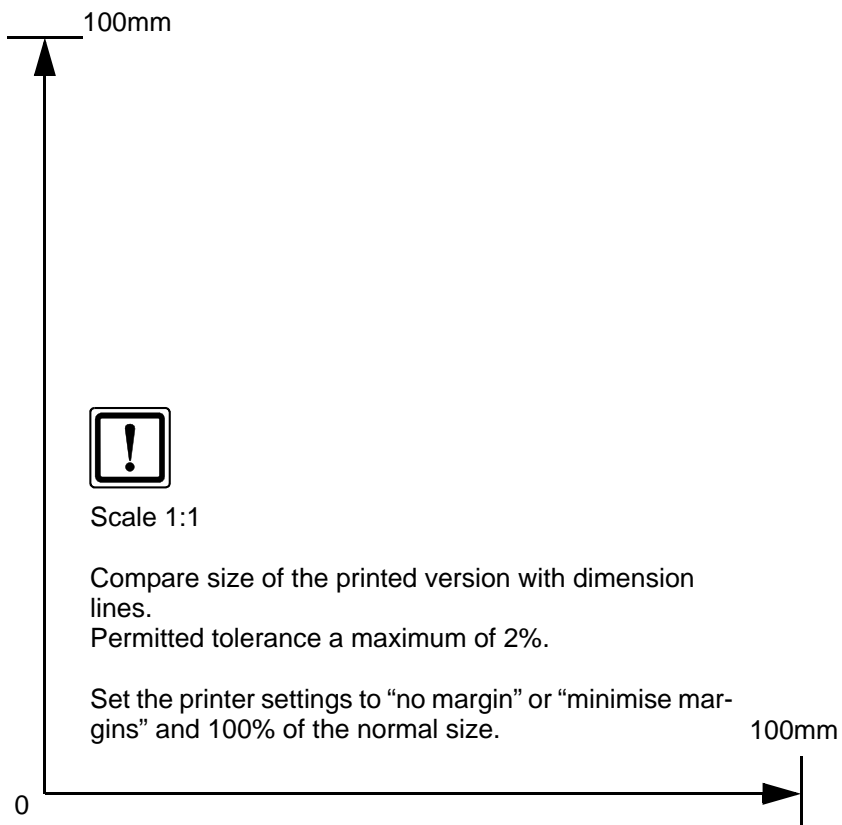

Operating Instructions for End Customer

Please remove this page in case of automatic air-conditioning and add it to the vehicle operating instructions.

Note:

We recommend matching the heating time to the driving time.

Heating time = driving time

Example:

For a driving time of approx. 20 min. (in one direction), we recommend not exceeding a switch-on time of 20 min.

Passenger compartment monitoring, if installed, must be deactivated in addition to the vehicle settings for the heating operation .

For instructions on deactivation, please refer to the operating instructions of the vehicle.

No settings needed on the A/C control panel.

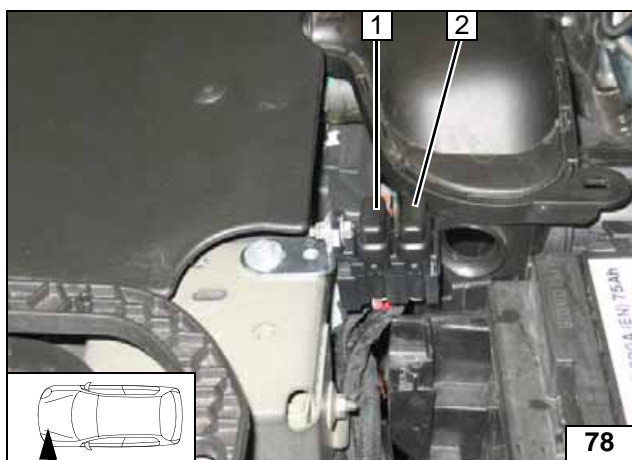

- 1 30A main fuse of passenger compartment F2
- 2 20A heater fuse F1

Fuses of engine compartment

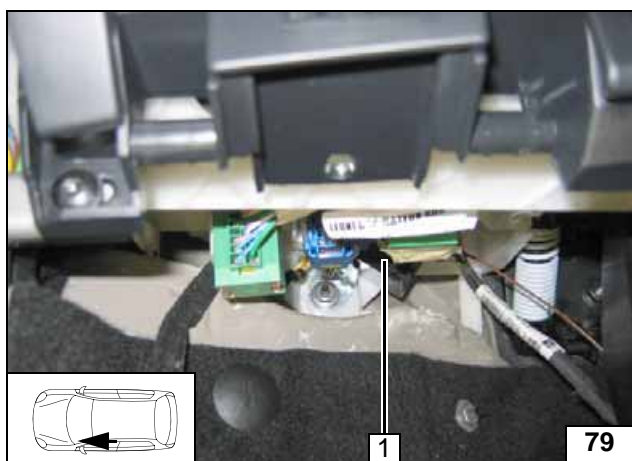

- 1 1A fuse of heater control F3 (hidden)

Fuse of passenger compartment

