

# Water Heater

## Thermo Top Evo Parking Heater



# Installation Documentation

## Skoda Fabia

### Validity

Manufacturer	Model	Type	EG-BE No./ ABE
Skoda	Fabia	5J	e1 * 2001 / 116 * 0291 * ...

Motorisation	Fuel	Transmission type	Output in kW	Displacement in cm <sup>3</sup>	Engine code
1.2 TDi	Diesel	SG	55	1199	CFWA
1.6 TDi	Diesel	SG	66	1598	CAYB
1.6 TDi	Diesel	SG	77	1598	CAYC

SG = manual transmission

from Model Year 2010

Left-hand drive vehicle

**Verified equipment variants:** Manual / automatic air-conditioning system

Front fog light

**Not verified:** Passenger compartment monitoring

**Total installation time:** approx. 12 hours

# Skoda Fabia

## Table of Contents

Validity	1	Preparing Installation Location	15
Necessary Components	2	Preparing Heater	16
Installation Overview	2	Installing Heater	20
Information on Total Installation Time	2	Fuel	21
Information on Operating and Installation Instructions	3	Combustion Air	25
Information on Validity	4	Coolant Circuit	26
Technical Information	4	Guard Plate	30
Explanatory Notes on Document	4	Underbody Trim	30
Preliminary Work	5	Final Work	31
Heater Installation Location	5	Template for Fuel Standpipe	32
Preparing Electrical System	6	Template for Bracket	33
Electrical System	9	Operating Instructions for Manual Air-Conditioning	34
Manual Air-Conditioning Fan Controller	10	Operating Instructions for Automatic Air-Conditioning	35
Automatic Air-Conditioning Fan Controller	12		
Remote Option (Telestart)	14		

## Necessary Components

- Basic delivery scope *Thermo Top Evo* in accordance with price list
- Installation kit for Skoda Fabia 2010 TDI Common Rail: **1316562B**
- Also required with automatic air-conditioning:  
Automatic Air-Conditioning kit for VW/Skoda MY 2009: **1323646A**
- Heater control in accordance with price list and upon consultation with end customer
- In case of Telestart, indicator lamp in accordance with price list and in consultation with end customer

## Installation instructions

- Arrange for the vehicle to be delivered with the tank only about 1/4 full.
- The installation location of the push button in the case of Telestart or Thermo Call should be confirmed with the end customer.
- Depending on the space required and the vehicle manufacturer's instructions, we recommend the use of a vehicle battery with a higher electrical capacity.

## Installation Overview

### Legend:

1. Heater
2. Engine compartment fuse holder
3. Passenger compartment relay and fuse holder
4. IPCU (only in case of automatic air-conditioning)
5. Circulating pump
6. Digital timer
7. Metering pump

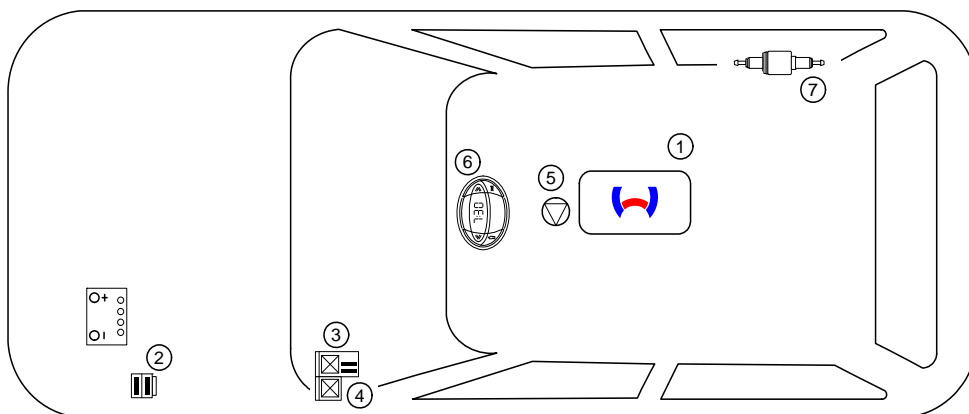

## Information on Total Installation Time

The total installation time includes the time needed for mounting and demounting of the vehicle-specific components, the heater specific installation time and all other times required for the system integration and initial start-up of the heater.

The total installation time may vary for vehicle equipment other than provided.

## Information on Operating and Installation Instructions

### 1 Important Information (not complete)

#### 1.1 Installation and Repair



The improper installation or repair of Webasto heating and cooling systems can cause fire or the leakage of deadly carbon monoxide, leading to serious injury or death.



To install and repair Webasto heating and cooling systems you need to have completed a special company training course and have the appropriate technical documentation, special tools and special equipment.



Installation and repair may ONLY be carried out by persons trained and certified in a Webasto training course. NEVER try to install or repair Webasto heating or cooling systems if you have not completed a Webasto training course, you do not have the necessary technical skills and you do not have the technical documentation, tools and equipment available to ensure that you can complete the installation and repair work properly.

Only use genuine Webasto parts. See the Webasto air and water heaters accessories catalogue for this purpose.

#### 1.2 Operation

To ensure safe operation, we recommend having the heater checked every two years by an authorised Webasto dealer, especially when used over a long period and/or under extreme environmental conditions.

Do not operate the heater in closed rooms due to the danger of poisoning and suffocation.

Always switch off the heater before refuelling.

The heater may only be used with the prescribed fuel Diesel (DIN EN 590) or petrol (DIN EN 228).

The heater may not be cleaned with a high-pressure cleaner.

#### 1.3 Please note

ALWAYS follow all Webasto installation and operating instructions and observe all warnings.

To become familiar with and understand all functions and properties of the heater, the operating instructions must be read carefully and observed at all times.

For proper, safe installation and repair work, the installation instructions with all warnings and safety information must be carefully read and observed at all times. Please always contact a workshop authorised by Webasto for all installation and repair work.

#### Important

**Webasto shall assume no liability for defects, damage and injuries resulting from a failure to observe the installation, repair and operating instructions of the information contained in them.**

**This liability exclusion particularly applies to improper installations and repairs, installations and repairs by untrained persons or in the case of a failure to use genuine spare parts.**

**The liability due to culpable disregard to life, limb or health and due to damage or injuries caused by a wilful or reckless breach of duty remain unaffected, as does the obligatory product liability.**

**Installation should be carried out according to the general, standard rules of technology. Unless specified otherwise, fasten hoses, lines and wiring harnesses to original vehicle lines and wiring harnesses using cable ties. Insulate loose wire ends and tie back. Connectors on electronic components must audibly snap into place during assembly.**

**Sharp edges should be fitted with rub protection. Spray unfinished body areas, e.g. drilled holes, with anti-corrosion wax (Tectyl 100K, Order No. 111329).**

**Observe the instructions and guidelines of the respective vehicle manufacturer for demounting and mounting vehicle specific components!**

**The initial startup is to be executed with the Webasto Thermo Test Diagnosis.**

**When installing a programmable control module (e.g. a PWM Gateway), the corresponding settings must be checked or adjusted.**

### 2 Statutory regulations governing installation

Guidelines	Thermo Top Evo
Heating Directive ECE R122	E1 00 0258
EMC Directive ECE R10	E1 04 5627

#### Note

The regulations of these guidelines are binding in the scope of the Directive 70/156/EEC and/or 2007/46/EC (for new vehicle models from 29/04/2009) and should also be observed in countries in which there are no special regulations.

#### Important

Failure to follow the installation instructions will result in the invalidation of the type approval for the heater and therefore invalidation of the general **homologation of the vehicle**.

#### Note

The heater is licensed in accordance with paragraph 19, section 3, No. 2b of the StVZO (German Road Traffic Licensing Authority).

### 2.1 Excerpt from ECE regulation 122 (heating system) paragraph 5 for the installation of the heater

Beginning of excerpt.

#### ANNEX VII

#### REQUIREMENTS FOR COMBUSTION HEATERS AND THEIR INSTALLATION

##### 1. GENERAL REQUIREMENTS

1.7.1. A clearly visible tell-tale in the operator's field of view shall inform when the combustion heater is switched on or off.

##### 2. VEHICLE INSTALLATION REQUIREMENTS

###### 2.1. Scope

2.1.1. Subject to paragraph 2.1.2. combustion heaters shall be installed according to the requirements of this Annex.

2.1.2. Vehicles of category O having liquid fuel heaters are deemed to comply with the requirements of this Annex.

###### 2.2. Positioning of heater

2.2.1. Body sections and any other components in the vicinity of the heater must be protected from excessive heat and the possibility of fuel or oil contamination.

2.2.2. The combustion heater shall not constitute a risk of fire, even in the case of overheating. This requirement shall be deemed to be fulfilled if the installation ensures an adequate distance to all parts and suitable ventilation, by the use of fire resistant materials or by the use of heat shields.

2.2.3. In the case of M2 and M3 vehicles, the heater must not be positioned in the passenger compartment. However, an installation in an effectively sealed envelope which also complies with the conditions in paragraph 2.2.2 may be used.

2.2.4. The label referred to in paragraph 1.4 or a duplicate, must be positioned so that it can be easily read when the heater is installed in the vehicle.

2.2.5. Every reasonable precaution should be taken in positioning the heater to minimise the risk of injury and damage to personal property.

###### 2.3. Fuel supply

2.3.1. The fuel filler must not be situated in the passenger compartment and must be provided with an effective cap to prevent fuel spillage.

2.3.2. In the case of liquid fuel heaters, where a supply separate to that of the vehicle is provided, the type of fuel and its filler point must be clearly labelled.

2.3.3. A notice, indicating that the heater must be shut down before refuelling, must be affixed to the fuelling point. In addition a suitable instruction must be included in the manufacturer's operating manual.

###### 2.4. Exhaust system

2.4.1. The exhaust outlet must be located so as to prevent emissions from entering the vehicle through ventilators, heated air inlets or opening windows.

###### 2.5. Combustion air inlet

2.5.1. The air for the combustion chamber of the heater must not be drawn from the passenger compartment of the vehicle.

2.5.2. The air inlet must be so positioned or guarded that blocking by rubbish or luggage is unlikely.

###### 2.6. Heating air inlet

2.6.1. The heating air supply may be fresh or recirculated air and must be drawn from a clean area not likely to be contaminated by exhaust fumes emitted either by the propulsion engine, the combustion heater or any other vehicle source.

2.6.2. The inlet duct must be protected by mesh or other suitable means.

###### 2.7. Heating air outlet

2.7.1. Any ducting used to route the hot air through the vehicle must be so positioned or protected that no injury or damage could be caused if it were to be touched.

2.7.2. The air outlet must be so positioned or guarded that blocking by rubbish or luggage is unlikely.

End of excerpt.

In multilingual versions the German language is binding.

# Skoda Fabia

## Information on Validity

This installation documentation applies to Skoda Fabia TDI Common Rail vehicles - for validity, see page 1 - from model year 2010 and later, assuming technical modifications to the vehicle do not affect installation, any liability claims excluded. Depending on the vehicle version and equipment, modifications may be necessary during installation with respect to this installation documentation.

Vehicle and engine types, equipment variants and other specifications not listed in this installation documentation have not been tested. However, installation according to this installation documentation may be possible.

## Technical Information

### Special tools

- Hose clamp pliers for self-clamping hose clamps
- Hose clamp pliers for Clic hose clamps of type W
- Automatic wire stripper 0.2 - 6mm<sup>2</sup>
- Crimping pliers for cable lug / tab connector 0.5 - 6mm<sup>2</sup>
- Torque wrench for 2.0 - 10 Nm
- Hose clamping pliers
- Metric thread-setter kit
- Webasto Thermo Test Diagnosis with current software

### Dimensions

- All dimensions are in mm

### Tightening torque values

- Tightening torque values of 5x13 heater bolts and 5x11 heater stud bolts = 8Nm.
- Tightening torque values of 5x15 retaining plate of water connection piece bolts = 7Nm.
- Tighten other bolt connections in accordance with manufacturer's instructions or in accordance with state-of-the-art-technology.

## Explanatory Notes on Document

You will find an identification mark on the outside top right corner of the page in question to provide you with a quick overview of the individual working steps.

Special features are highlighted using the following symbols:

**Mechanical system**



**Specific risk of injury or fatal accidents**



**Electrical system**



**Specific risk due to electrical voltage**



**Coolant circuit**

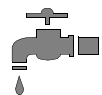

**Specific risk of damage to components**



**Combustion air**

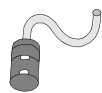

**Specific risk of fire or explosion**



**Fuel**



**Reference to general installation instructions of the Webasto components or to the manufacturer's vehicle-specific documents**



**Reference to a special technical feature**



**Exhaust gas**



**The arrow in the vehicle icon indicates the position on the vehicle and the viewing angle**

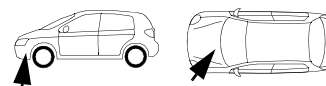

**Software**



**Tightening torque according to the manufacturer's vehicle-specific documents**



# Skoda Fabia

## Preliminary Work

### Vehicle

- Open the fuel tank cap.
- Ventilate the fuel tank.
- Close the fuel tank cap again.
- Depressurise the cooling system.
- Remove the battery.
- Remove the underride protection.
- Remove the right vehicle underbody trim.
- Remove the driver's seat
- Remove the entrance strip on the driver's side.
- Remove the front passenger's seat.
- Remove the entrance strip on front passenger's side.
- Remove the centre tunnel trim.
- Fold back the footwell trim.
- Remove the rear area air duct.
- Fold up the seating surface of the rear bench seat.
- Open the tank-fitting service lid.
- Remove the light switch.
- Detach the central electrical box under the steering wheel.
- Remove the A/C control panel (only with automatic air-conditioning).
- Remove the side instrument panel trim on the left.

### Heater

- Remove years that do not apply from the type and duplicate label.
- Attach the duplicate label (type label) in the appropriate place in the engine compartment.

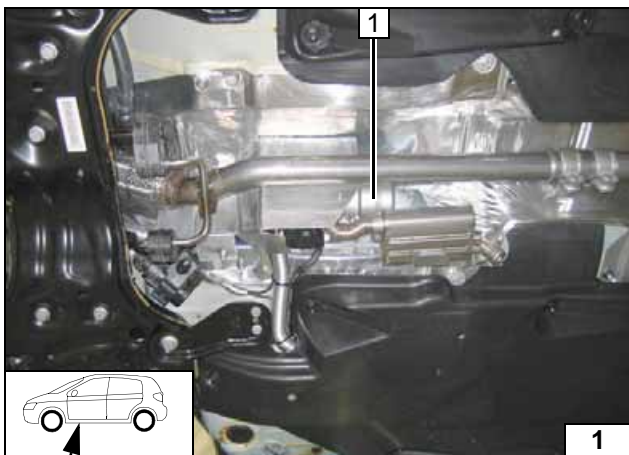

### Heater Installation Location

- 1 Heater

Installation location

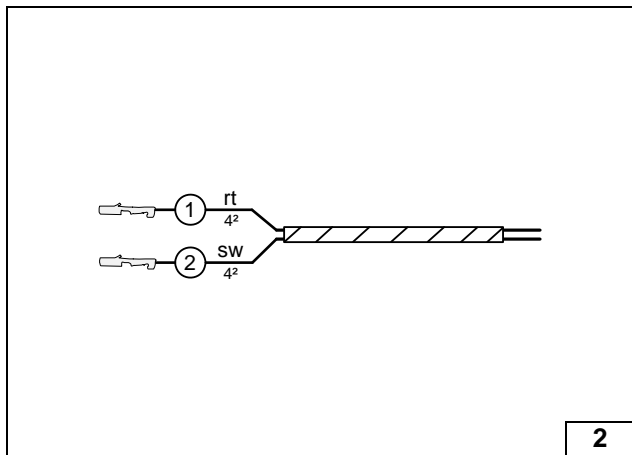

### Preparing Electrical System

Wire sections retain their numbering in the entire document.

Produce all following electrical connections as shown in the wiring diagram.

#### All vehicles

- ① Red (rt) wire of fan wiring harness
- ② Black (sw) wire of fan wiring harness



Assigning wires

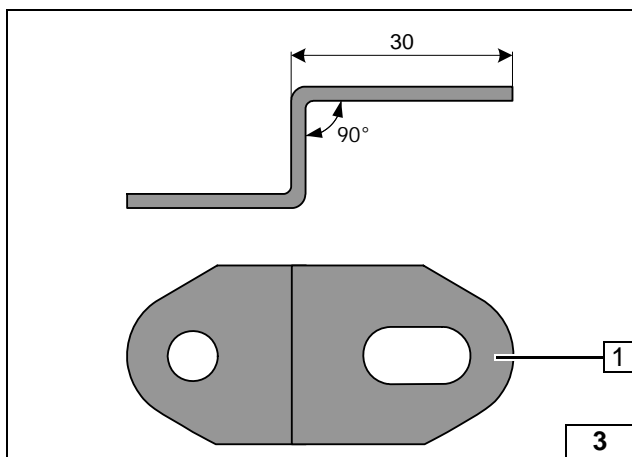

1 Angle bracket



Bending angle bracket

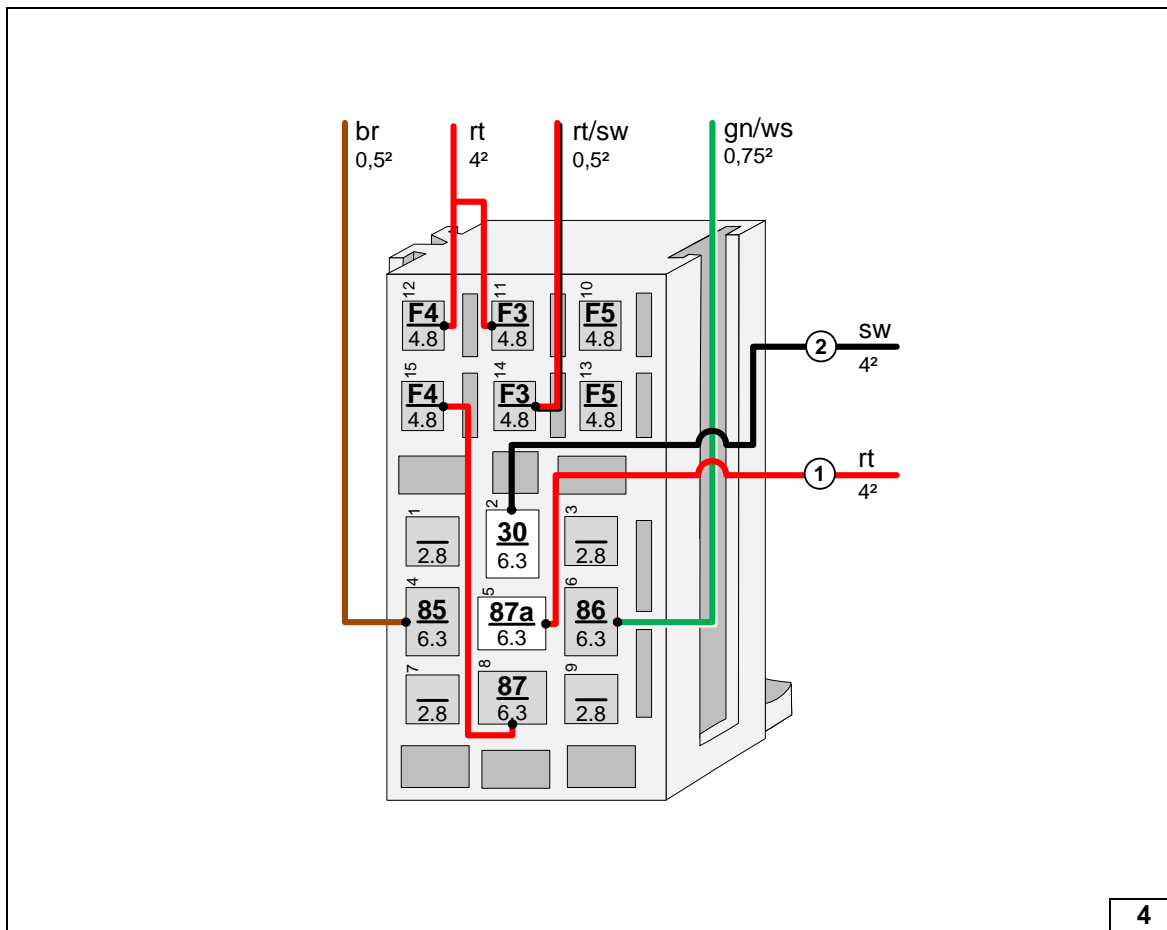

Connecting wires to passenger compartment relay and fuse holder

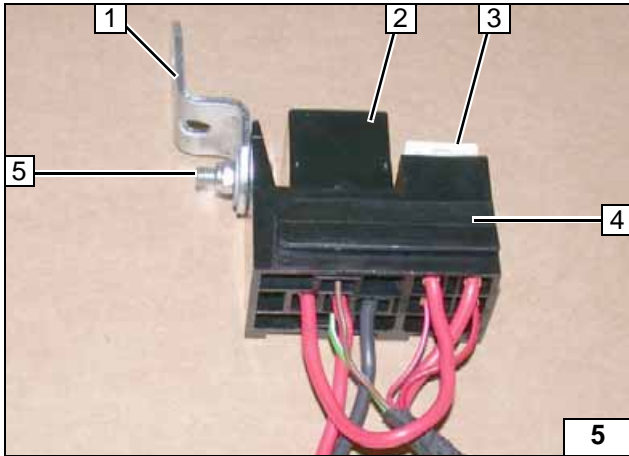
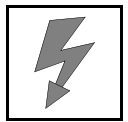

- 1 Angle bracket
- 2 K1 relay
- 3 25A fuse F4
- 4 Passenger compartment relay and fuse holder
- 5 M5x12 bolt, washer, nut

Preparing relay and fuse holder of passenger compartment

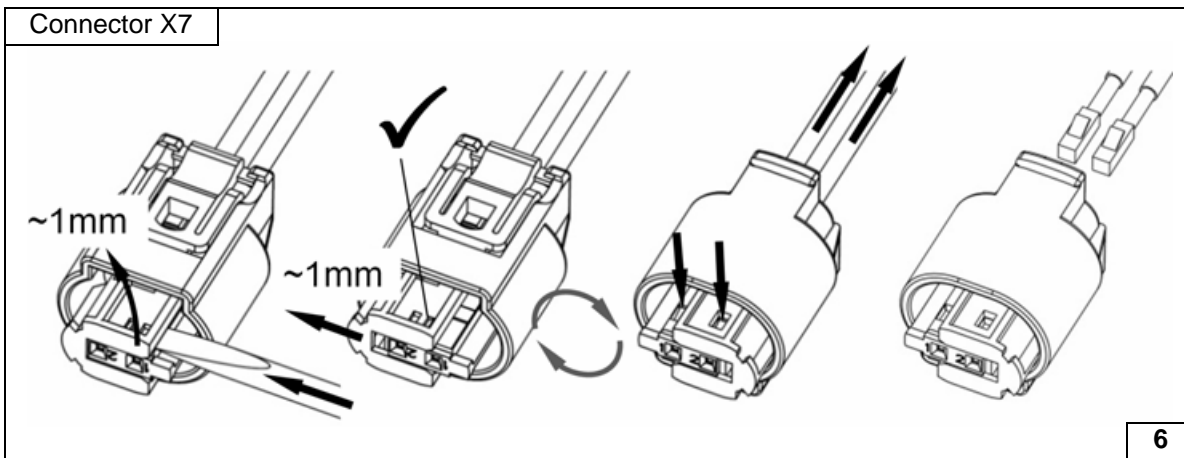

Dismantling connector of metering pump

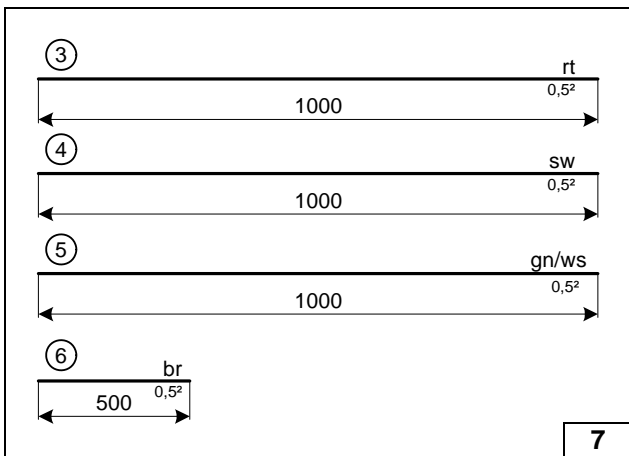

**Automatic air-conditioning**

Pull wire sections ③ and ④ into provided protective sleeving.



Assigning wires

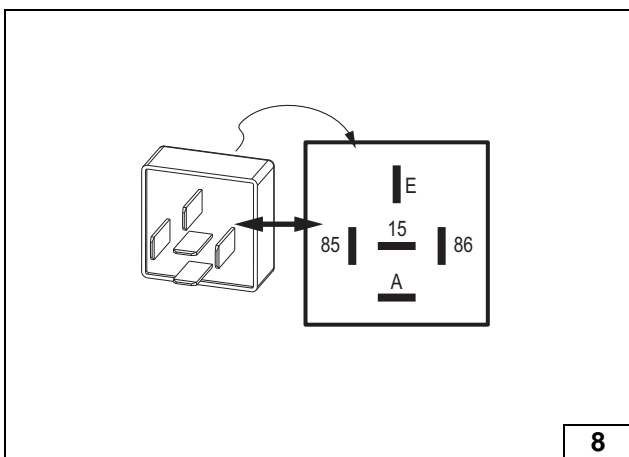

The settings must be checked during the start-up of the heater and adjusted if necessary.

**Settings:**

- Duty cycle: 100%
- Frequency: not relevant
- Voltage: 3.6V
- Function: High-side



Premounting IPCU

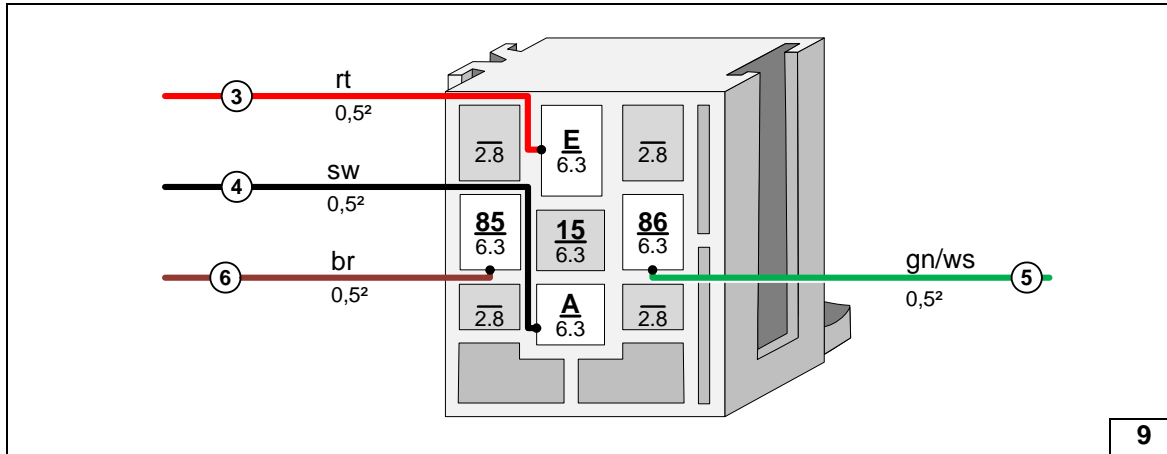

Connecting wires to IPCU socket

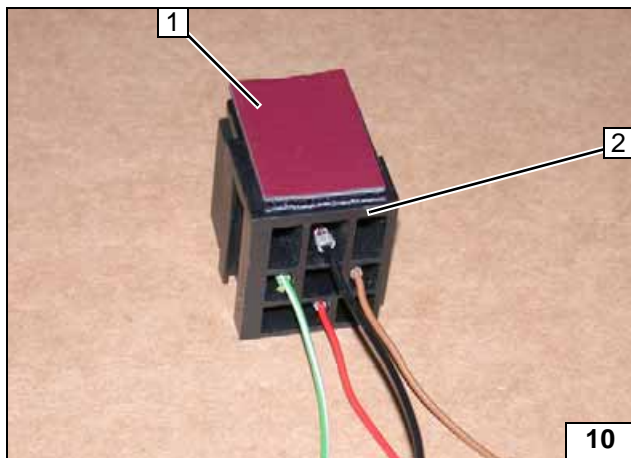

Mount IPCU on Socket 2 after installation.

- 1 Double-sided adhesive tape
- 2 IPCU socket



Preparing IPCU

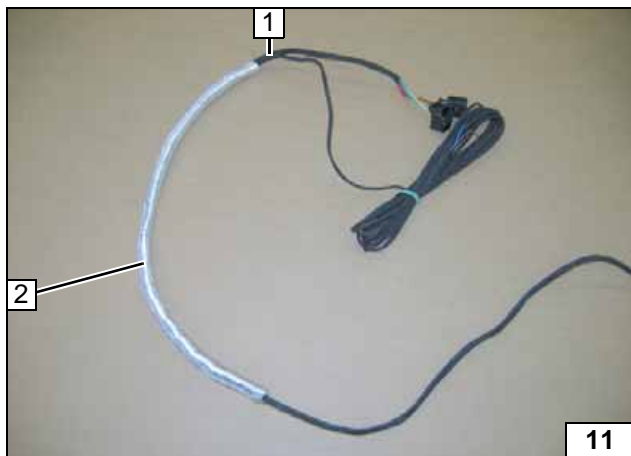

540 mm long protective pipe 2, slit along length and slide onto wiring harness of heater 1.



Sliding on protective pipe





**Electrical System**

**Connection to positive battery terminal**

- 1 Positive distributor on battery
- 2 Positive wire to secured connection

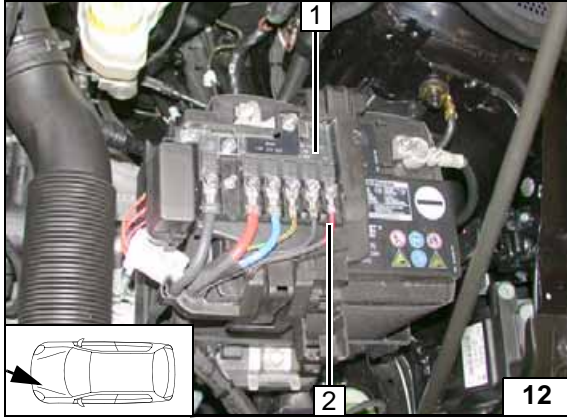

**Digital timer**

- 1 Digital timer

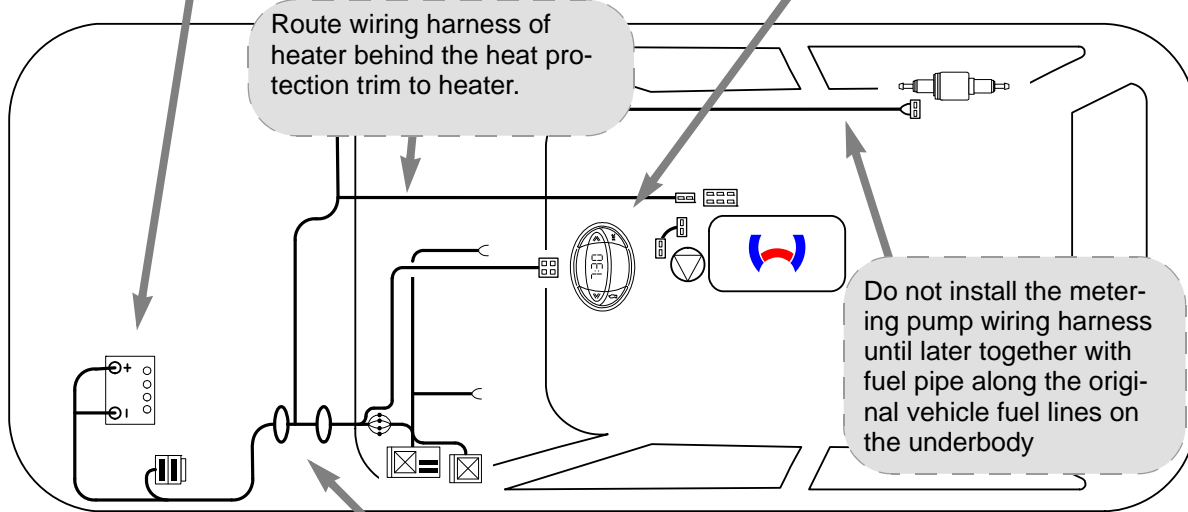
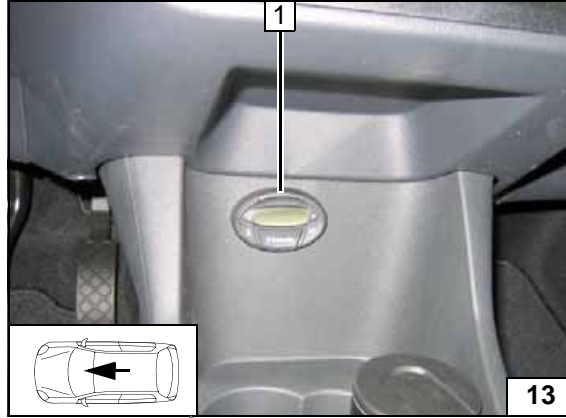

**Wiring harness routing diagram**

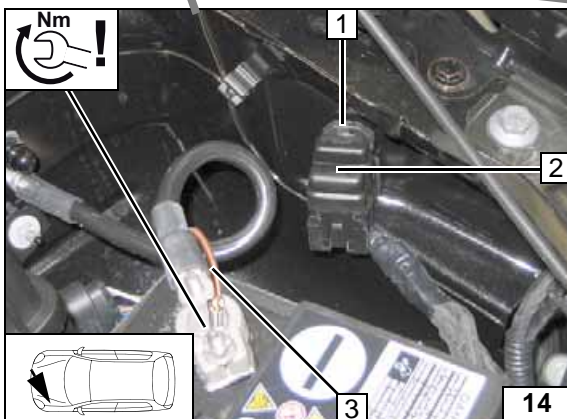

**Engine compartment fuse holder, earth connection**

- 1 4.5mm dial hole; 5.5x13mm self-tapping screw, retaining plate of fuse holder
- 2 F1-2 fuses mounted
- 3 Earth wire on negative battery terminal



**Wiring harness pass through of passenger compartment**

- 1 Protective rubber plug pass through coolant reservoir
- 2 Wiring harness of engine compartment fuse holder



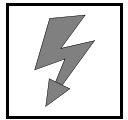

Manual Air-Conditioning Fan Controller

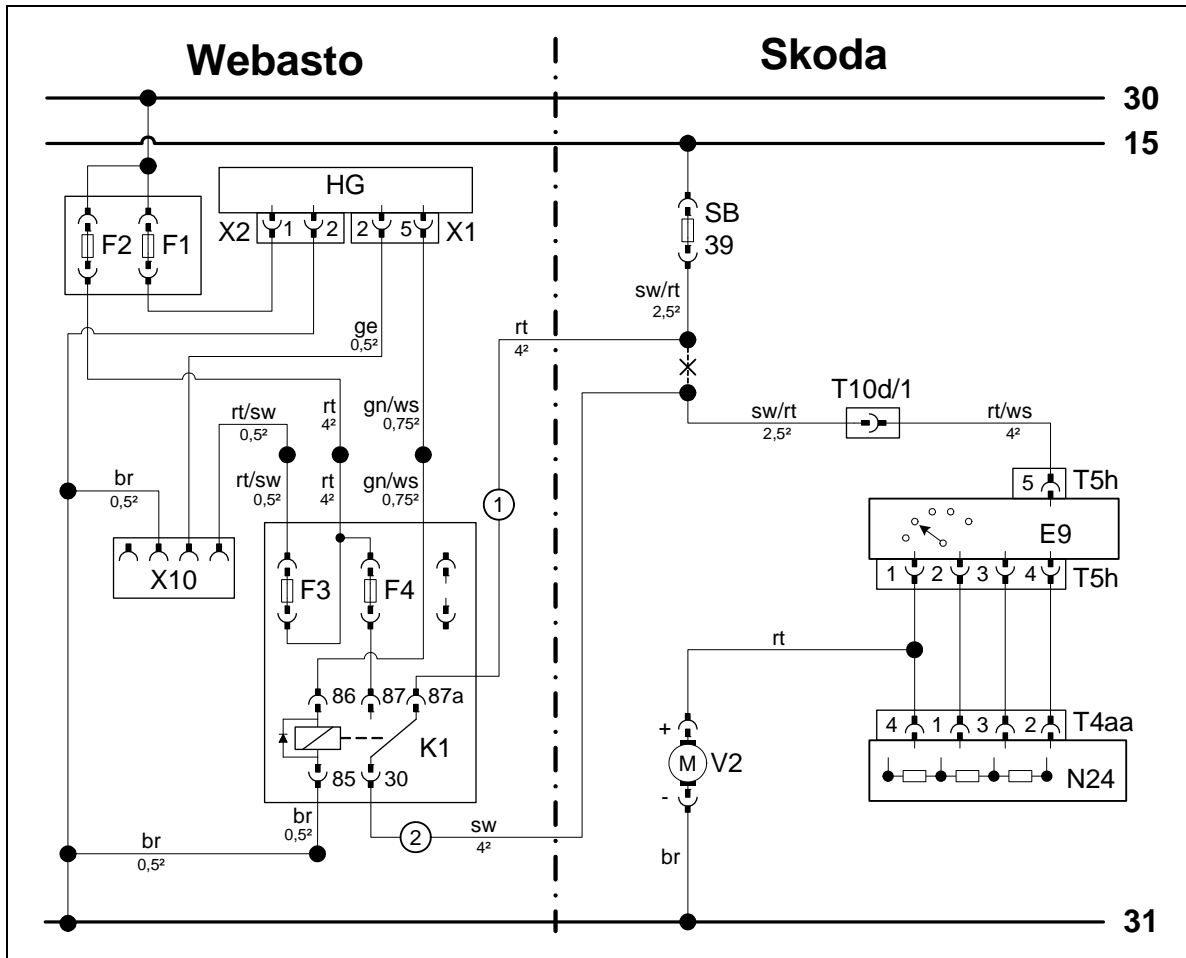

Wiring diagram

Webasto components		Vehicle components		Colours and symbols	
HG	Heater TT-Evo	SB39	30A fuse	rt	red
X1	6-pin heater connector	T...	Connector	ws	white
X2	2-pin heater connector	E9	Switch unit	sw	black
F1	20A fuse	V2	Fan motor	br	brown
F2	30A fuse	N24	Resistor group	gn	green
X10	4-pin connector of heater control			ge	yellow
F3	1A fuse				
F4	25A fuse			X	Cutting point
K1	Fan relay			Wiring colours may vary.	

Legend

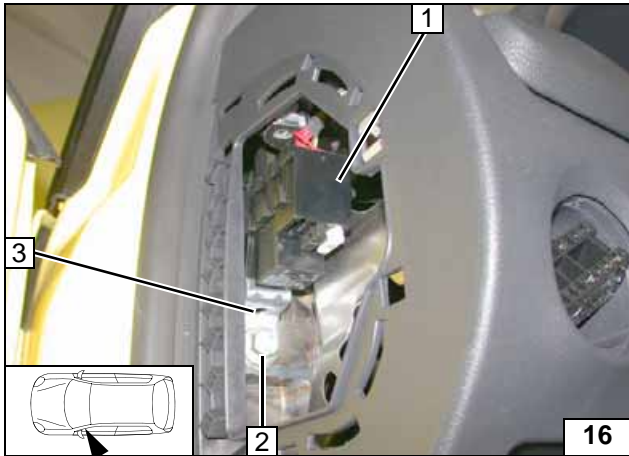

- 1 Passenger compartment relay and fuse holder
- 2 Original vehicle bolt
- 3 Angle bracket

**Mounting passenger compartment relay and fuse holder**

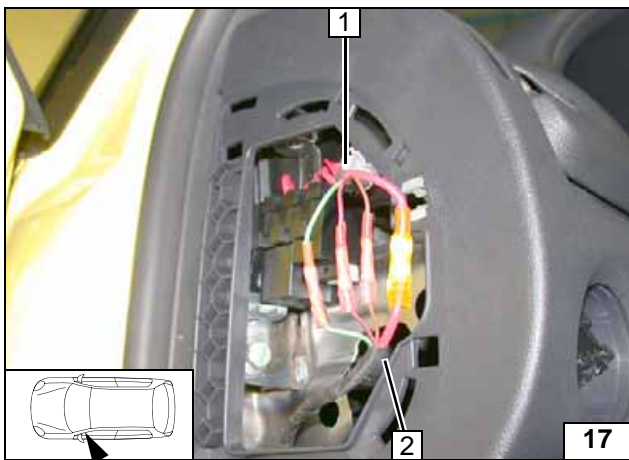

Connect same colour wires of wiring harness in the relay and fuse holder of passenger compartment 1 and wiring harness of heater 2 according to wiring diagram.



**Connecting wiring harnesses**

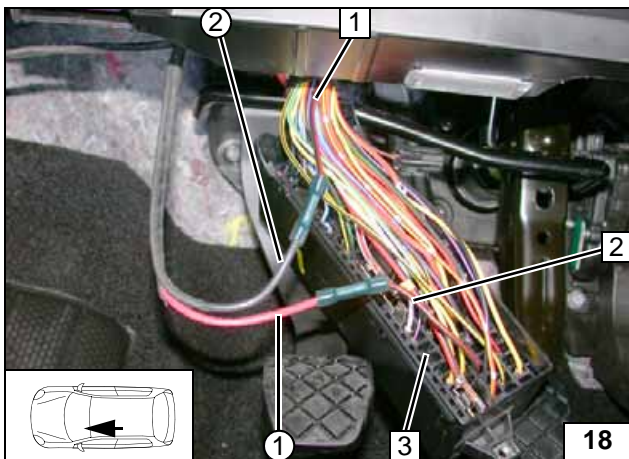

- 1 Black/red (sw/rt) wire of fan unit
- 2 Black/red (sw/rt) wire of fuse SB39
- 3 Central electrical box
- ① Red (rt) wire from K1/87a fan wiring harness
- ② Black (sw) wire from K1/30 fan wiring harness

**Connecting central electrical box**

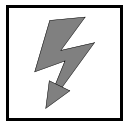

Automatic Air-Conditioning Fan Controller



Wiring diagram

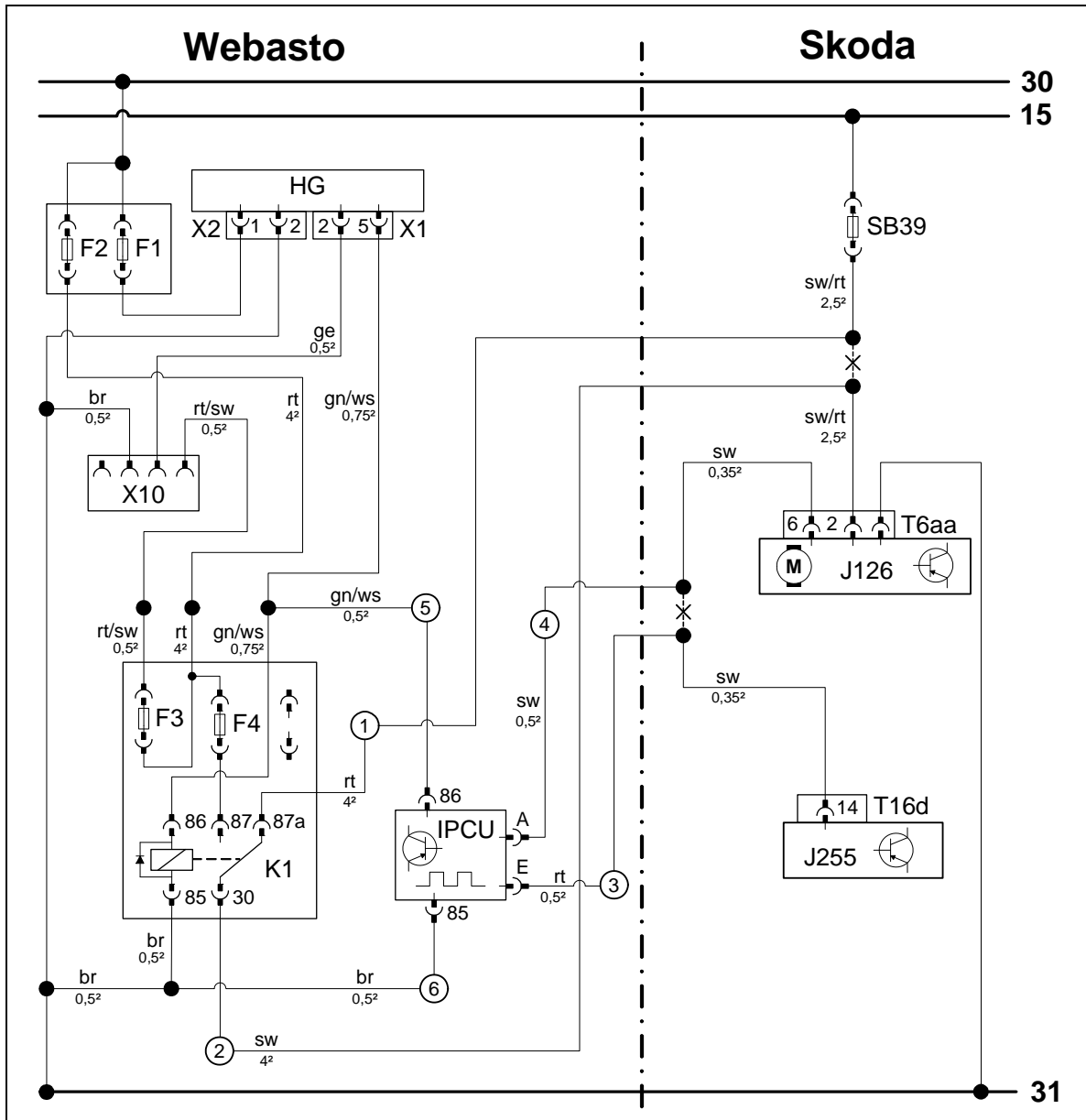

Webasto components		Vehicle components		Colours and symbols	
HG	Heater TT-Evo	SB39	30A fuse	rt	red
X1	6-pin heater connector	T...	Connector	ws	white
X2	2-pin heater connector	J126	Fan unit	sw	black
F1	20A fuse	J255	A/C control panel	br	brown
F2	30A fuse			gn	green
X10	4-pin connector of heater control			ge	yellow
F3	1A fuse				
F4	25A fuse				
K1	Fan relay				
IPCU	Pulse width modulator				
<b>IPCU settings:</b>					
Duty cycle: 100%					
Frequency: not relevant					
Voltage: 3.6 V					
Function: High-side					
				X	Cutting point
Wiring colours may vary.					

Legend

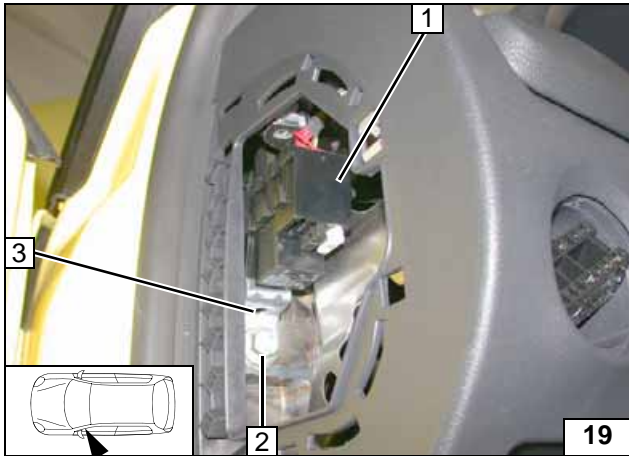

- 1 Passenger compartment relay and fuse holder
- 2 Original vehicle bolt
- 3 Angle bracket

**Mounting passenger compartment relay and fuse holder**

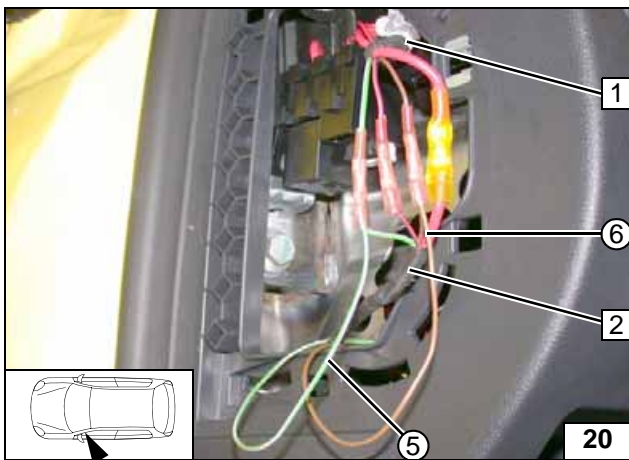

Connect wiring harness of passenger compartment relay and fuse holder 1 with wiring harness of heater 2, as well as brown (br) additional wire ⑥ and green/white (gn/ws) additional wire ⑤ using same colour wires according to the wiring diagram.



**Connecting wiring harnesses**

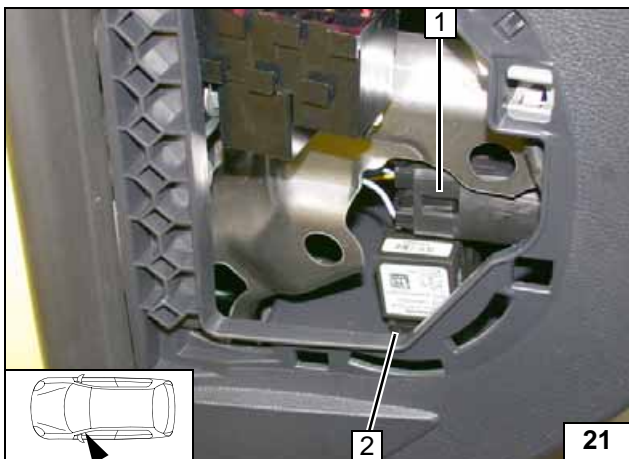

Ensure sufficient distance from light switch 1.

- 2 Stick on IPCU socket (double-sided adhesive tape)



**Installing IPCU**

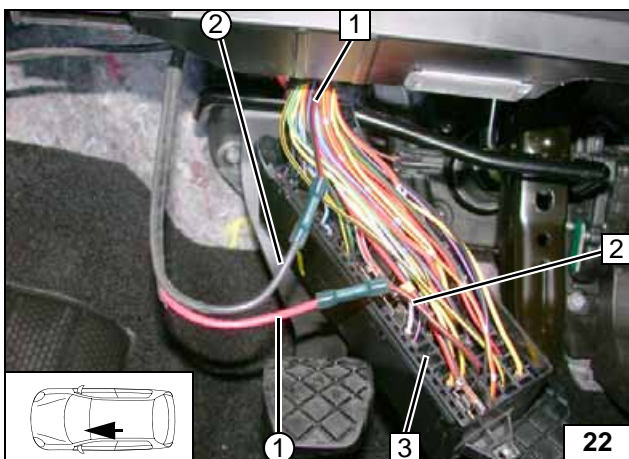

- 1 Black/red (sw/rt) wire of fan unit
- 2 Black/red (sw/rt) wire of fuse SB39
- 3 Central electrical box
- ① Red (rt) wire from K1/87a fan wiring harness
- ② Black (sw) wire from K1/30 fan wiring harness

**Connecting central electrical box**



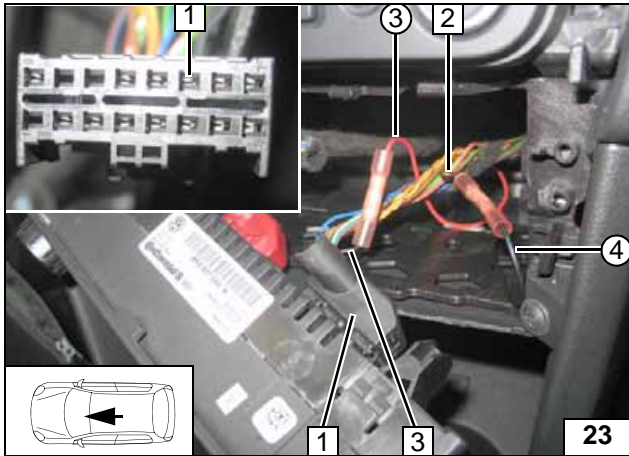

- 1 Connector T16d
- 2 Black (sw) wire of J126
- 3 Black (sw) wire of J255 / T16d Pin14
- ③ Red (rt) wire of IPCU/E
- ④ Black (sw) wire of IPCU/A



**Connect-  
ing air-con-  
ditioning  
control  
panel**

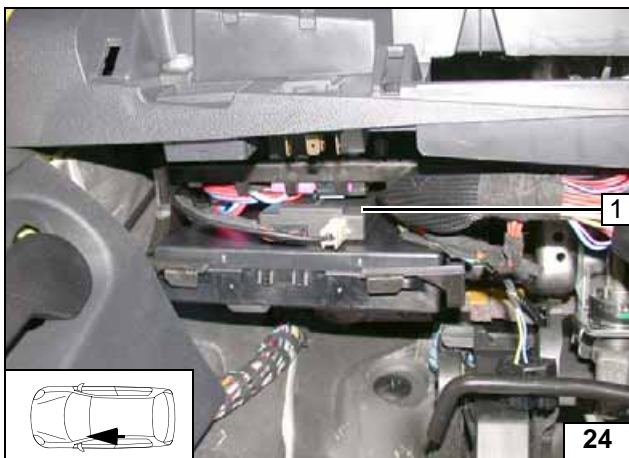

### Remote Option (Telestart)

Fasten receiver 1 with double-sided adhesive tape.



**Installing  
receiver**

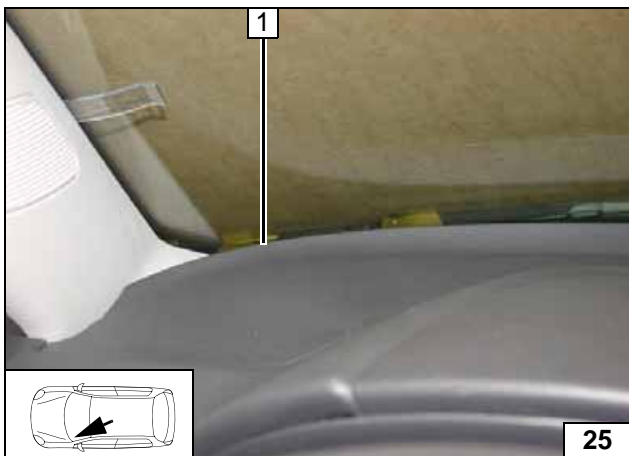

- 1 Antenna

**Installing  
antenna**

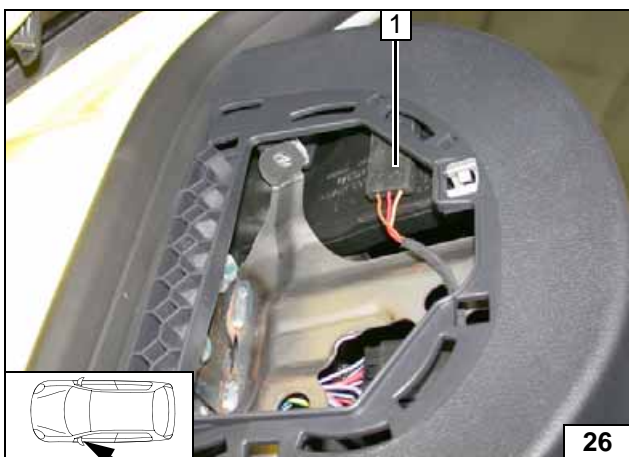

### Temperature sensor T100 HTM

Fasten temperature sensor 1 with double-sided adhesive tape.



**Installing tempera-  
ture sensor**

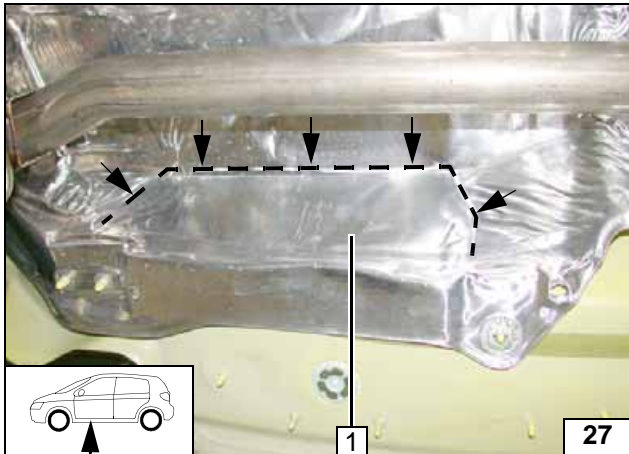

### Preparing Installation Location

Place heat guard plate 1 in the area of the marking on tunnel.



Placing heat guard plate

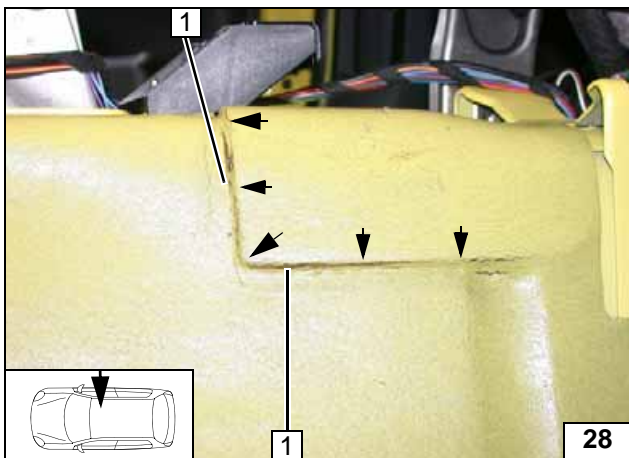
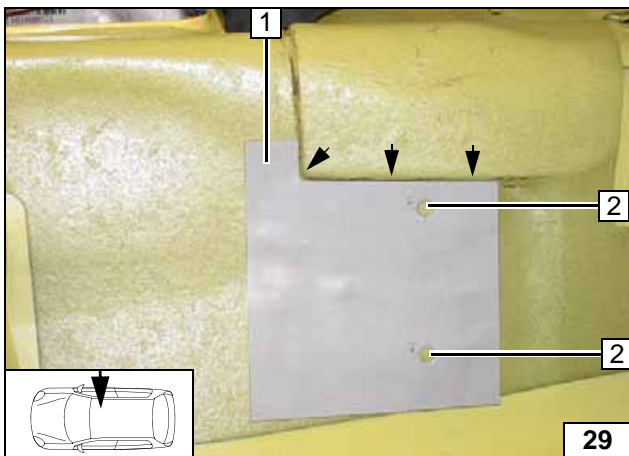

Figure shows centre tunnel on front passenger's side.

Warm up and place heat insulation mat 1 as shown.



Copying hole pattern



Cut out template 1 and place as shown, copy 7mm dia. hole pattern 2 [2x] and drill.



Preparing installation location

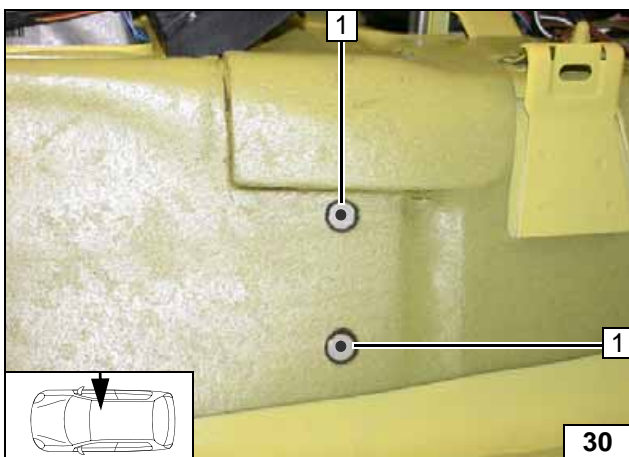

Cut out insulation mat in the area of the 15mm dia. hole 1 .



Preparing installation location

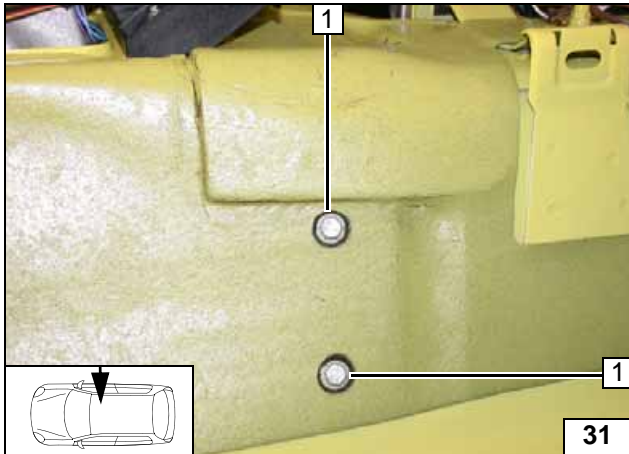

Insert M6x20 bolt 1 [2x] in the hole.



Preparing installation location

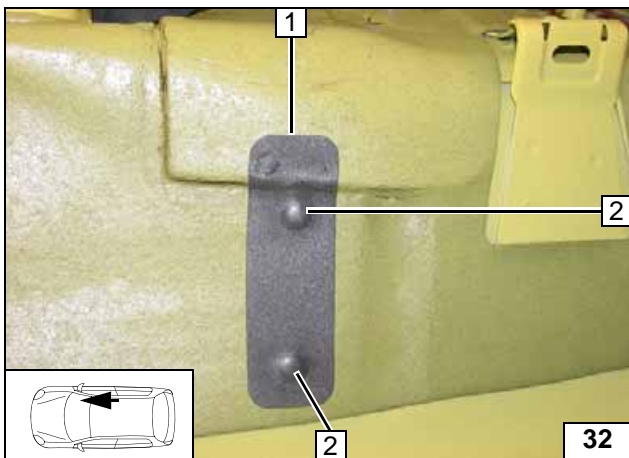

Glue self-adhesive base foam 1 on screw heads 2 [2x].



Preparing installation location

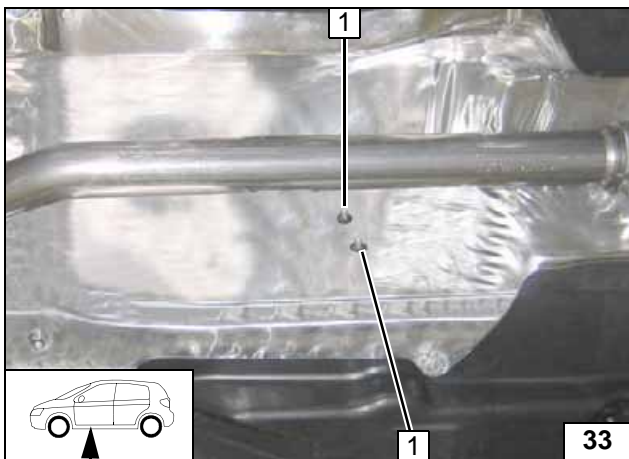

Secure each M6x20 bolt with a pin lock 1.



Mounting pin lock

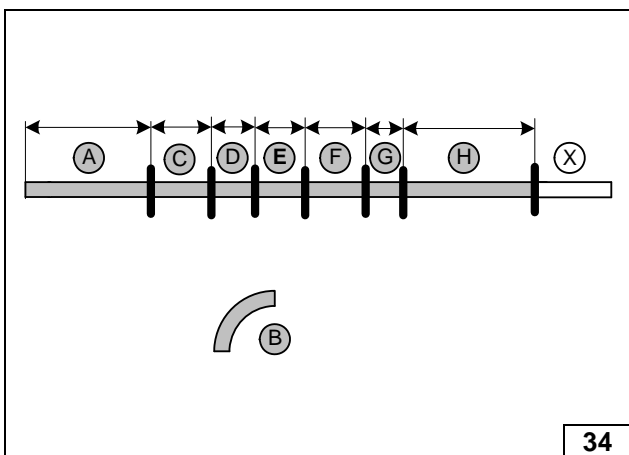

### Preparing Heater

Discard section X.

Hose B =90°, 18mm dia. moulded hose

- A = 420
- C = 145
- D = 80
- E = 115
- F = 140
- G = 60
- H = 460

Cutting hoses to length



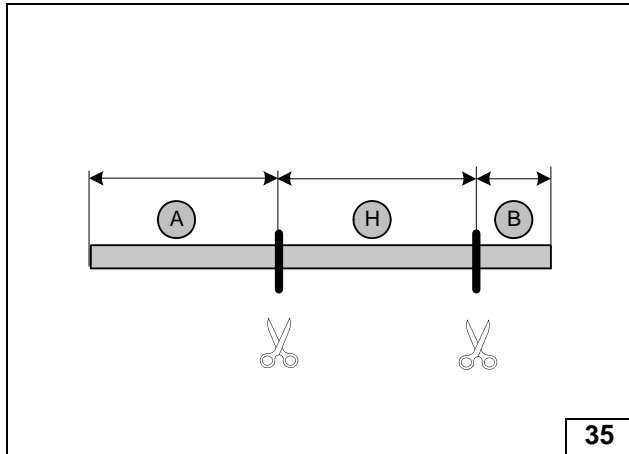

Discard section X.

- A = 350
- B = 50
- H = 400



Cutting heat protection hose to length

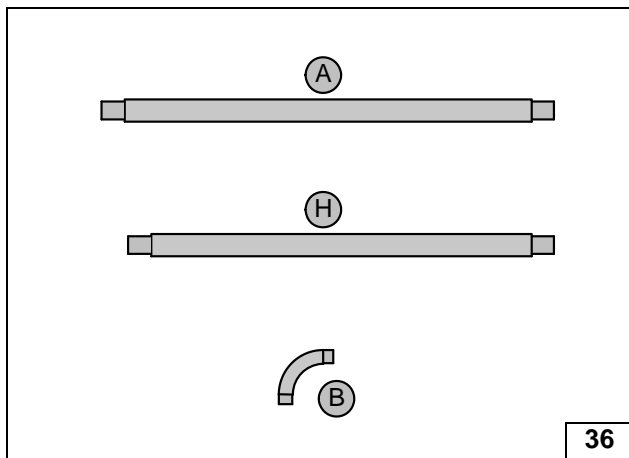

Sliding on heat protection hoses

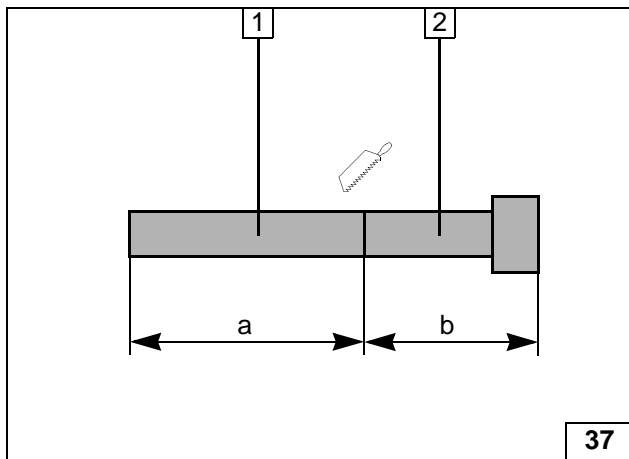

- 1 Exhaust pipe  
a = 100
- 2 Exhaust end section  
b = 50



Preparing exhaust pipe

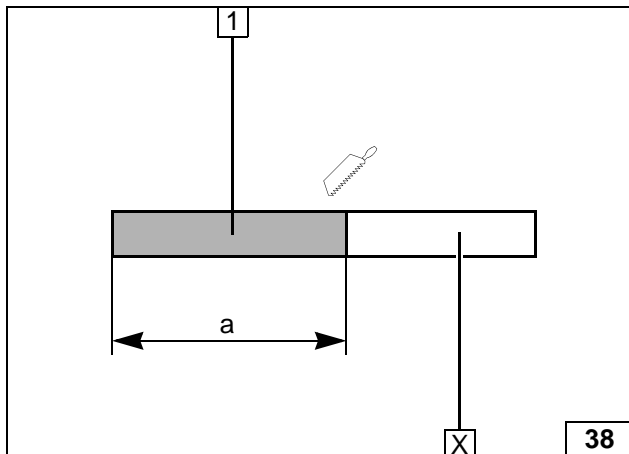

Discard section X.

- 1 Combustion air pipe  
a = 340



Cutting combustion air pipe to length

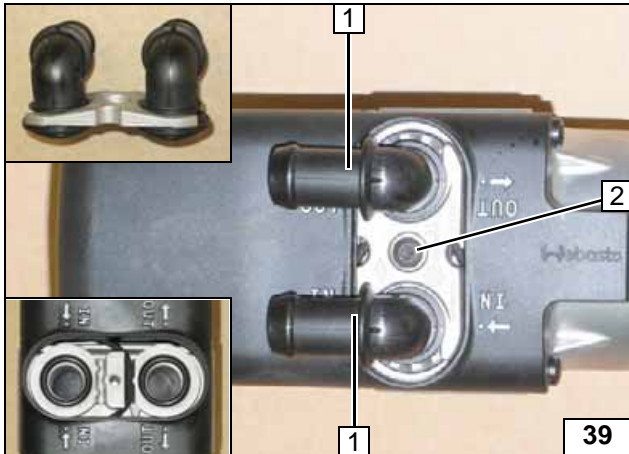

- 1 Water connection piece, sealing ring [2x each]
- 2 5x15 self-tapping bolt, retaining plate of water connection piece

Installing water connection piece



- 1 Moulded hose (fuel)
- 2 10 mm dia. clamp

Premounting heater

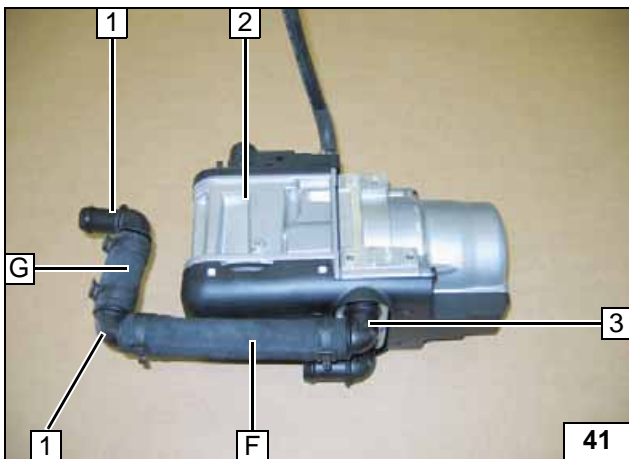

All spring clips 25mm dia.

- 1 90°, 18x18mm dia. connecting pipe [2x]
- 2 Heater
- 3 Water connection piece of heater outlet



Premounting heater

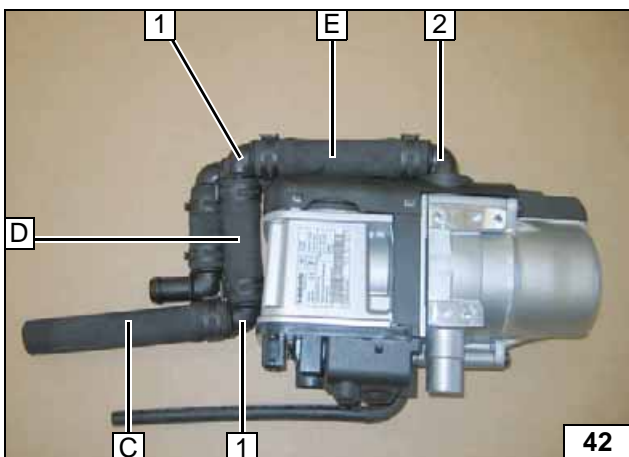

All spring clips 25mm dia.

- 1 90°, 18x18mm dia. connecting pipe [2x]
- 2 Water connection piece of heater inlet



Premounting heater

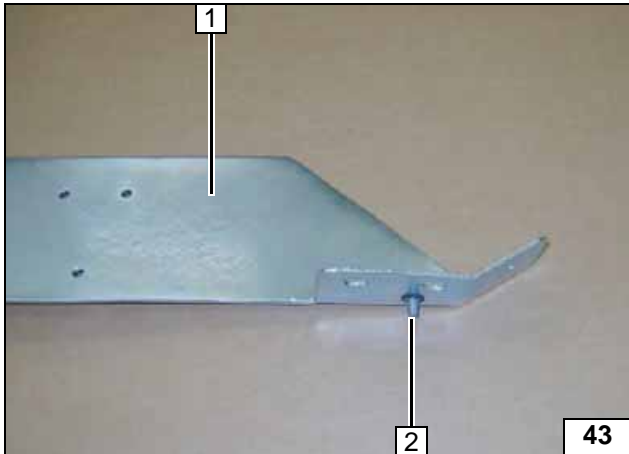

- 1 Bracket
- 2 M6x12 bolt, pin lock

Premounting bracket

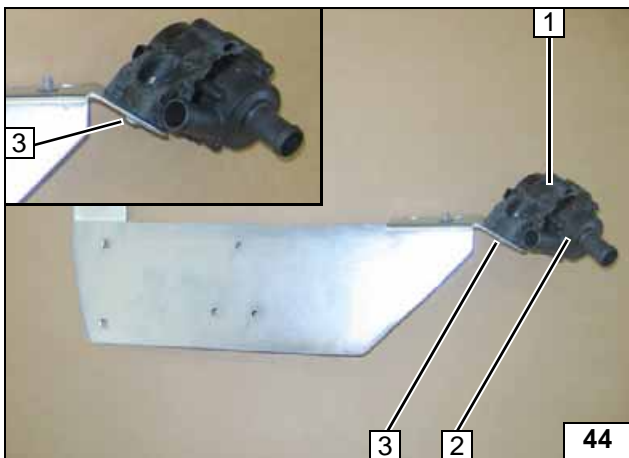

Install circulating pump 2 on bracket tightly.

- 1 Mount for circulating pump
- 3 M6x25 bolt, large diameter washer, flanged nut



Premounting bracket

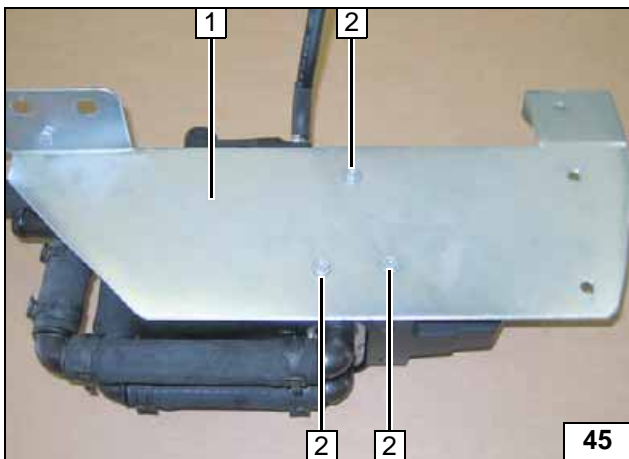

- 1 Bracket
- 2 5x13 self-tapping bolt [3x]

Installing bracket

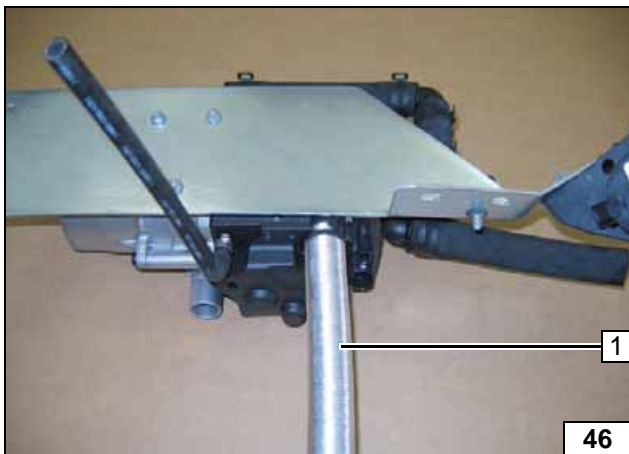

- 1 Combustion air pipe

Installing combustion air pipe

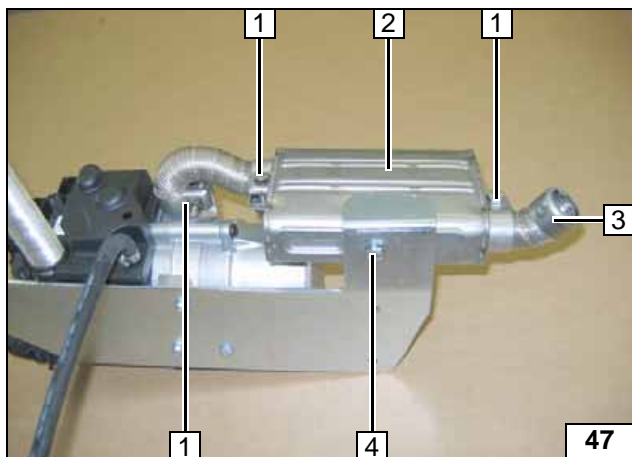

- 1 Hose clamp [3x]
- 2 Exhaust silencer
- 3 Exhaust end section
- 4 M6x16 bolt, spring lockwasher



Premounting heater

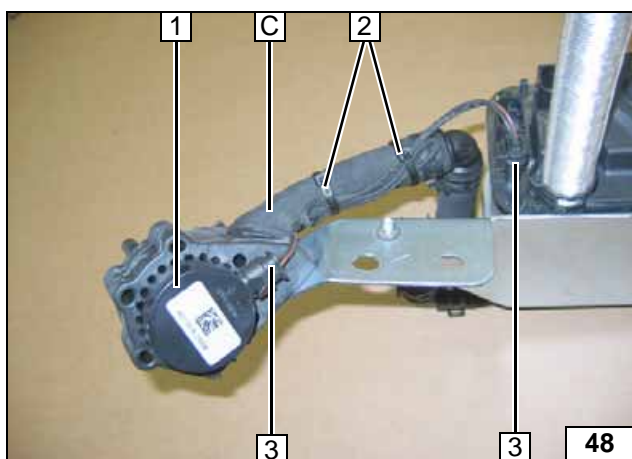

Install hose **C** with 25mm dia. spring clip on circulating pump **1**.

Tighten all screw connections.

- 1 Cable tie [2x]
- 2 Wiring harness of circulating pump



Premounting heater

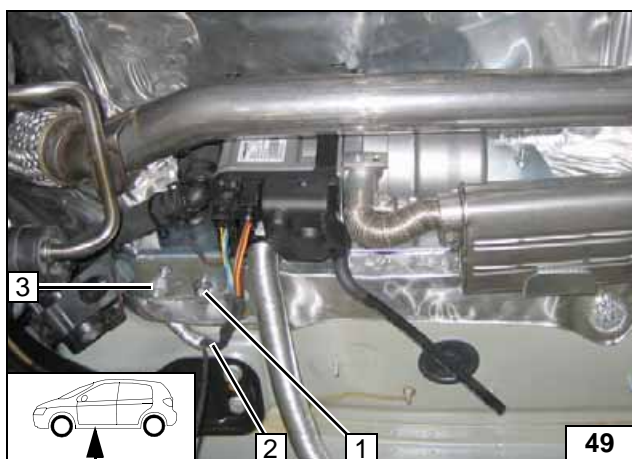

### Installing Heater

Route wiring harness **2** behind heat guard plate and mount it on heater.

- 1 Original vehicle M8 flanged nut
- 3 M8 flanged nut



Installing heater

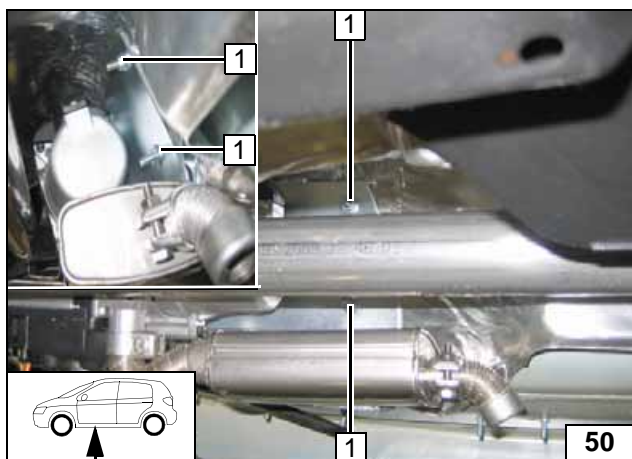

- 1 Flanged nut [2x], M6x20 bolt (premounted)

Installing heater

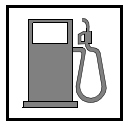

**Fuel**

**CAUTION!**

Open the vehicle's fuel tank cap, ventilate the tank and then re-close the tank lock.

Catch any fuel running off with an appropriate container.

Route fuel line and metering pump wiring harness so that they are protected against stone impact. Unless specified otherwise, always fasten using cable ties.

Provide rub protection for fuel line and wiring harness in areas where there are sharp edges.

**WARNING!**

The fuel line and wiring harness are routed to the metering pump as shown in the wiring harness routing diagram.

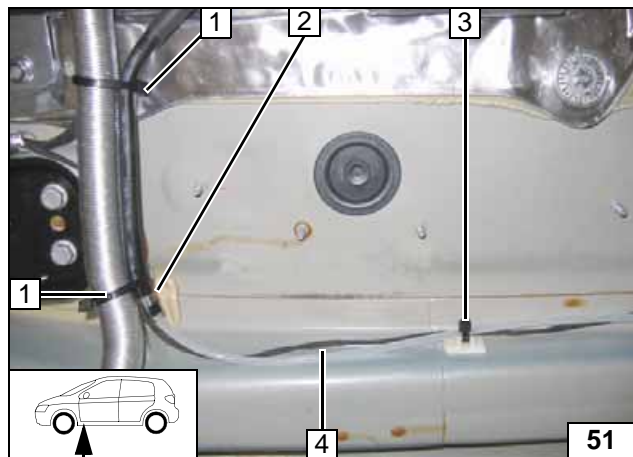

Remove grease from gluing point!

- 1 Cable tie [2x]
- 2 Moulded hose (premounted), 10 mm dia. clamp, fuel line
- 3 Adhesive base, clip-type cable tie
- 4 Fuel line, metering pump wiring harness



**Heater connection and routing**

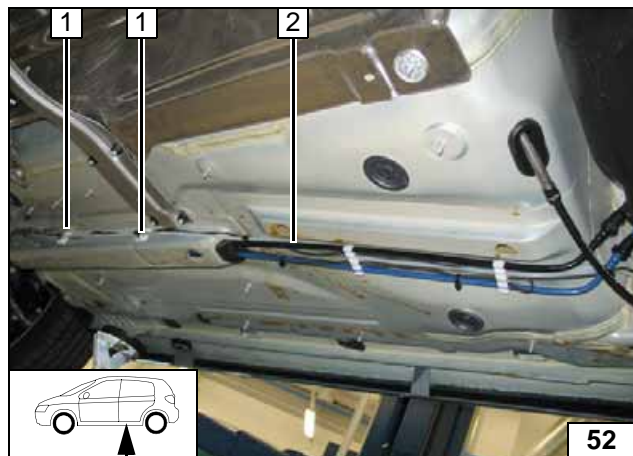

Route fuel line and wiring harness of metering pump 2 along original vehicle fuel lines and secure with cable ties. Remove grease from gluing points

- 1 Adhesive base, cable tie [2 each]



**Connecting heater**

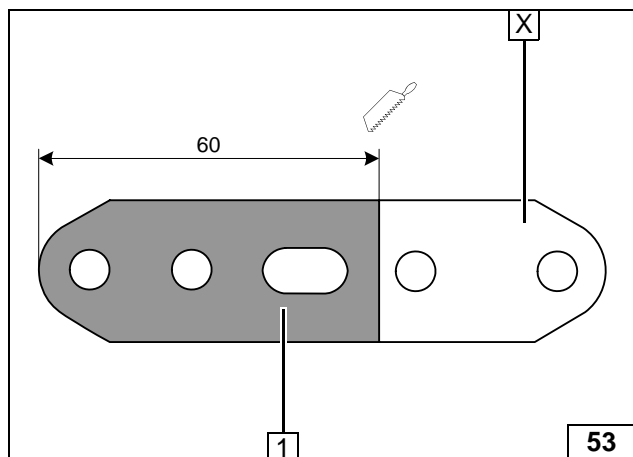

Discard section X.

- 1 Perforated bracket



**Cutting perforated bracket to length**



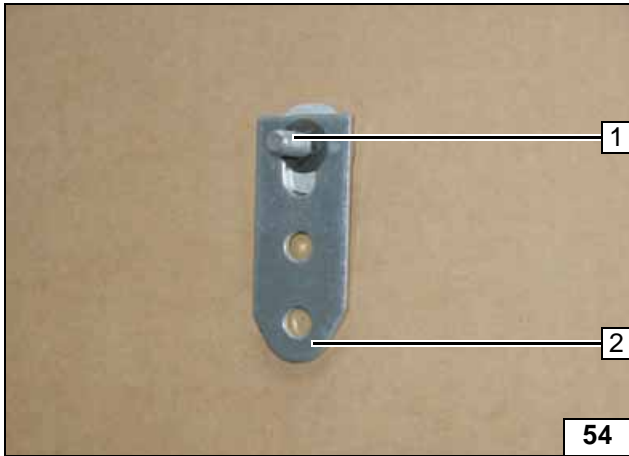
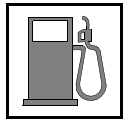

- 1 M6x25 bolt, large diameter washer, pin lock
- 2 Perforated bracket

Preparing perforated bracket

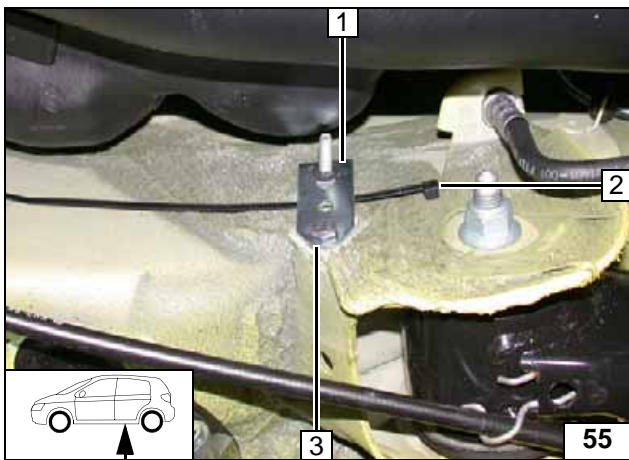

- 1 Perforated bracket
- 2 Cable tie
- 3 M6x20 bolt, large diameter washer, flanged nut

Installing perforated bracket

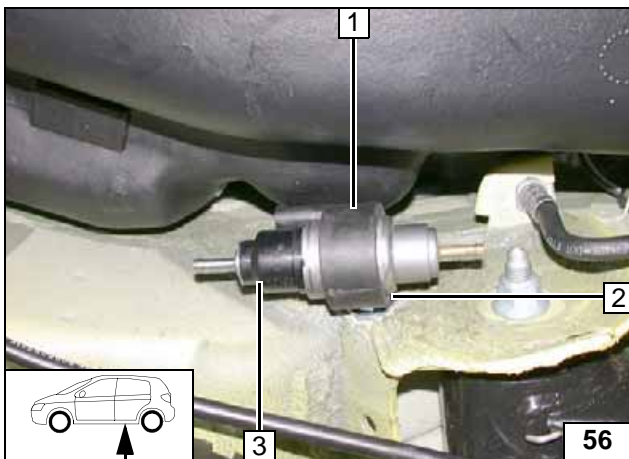

- 1 Metering pump mount, flanged nut
- 2 Cable tie drawn through mount of metering pump
- 3 Metering pump



Installing metering pump

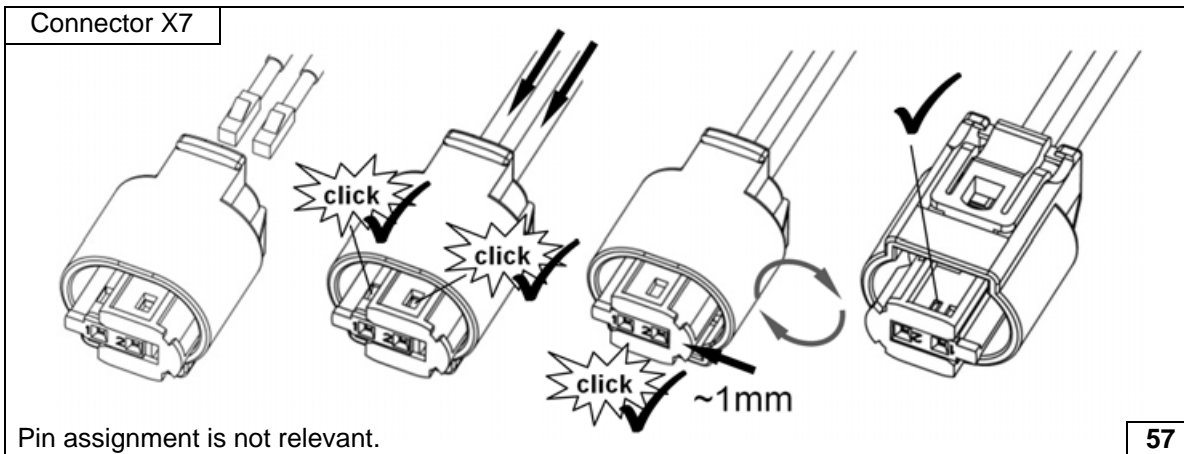

Completing connector of metering pump

Pin assignment is not relevant.



**Connect-  
ing meter-  
ing pump**



**Fuel ex-  
traction**



**Installing  
fuel stand-  
pipe**



**Connect-  
ing fuel  
line**

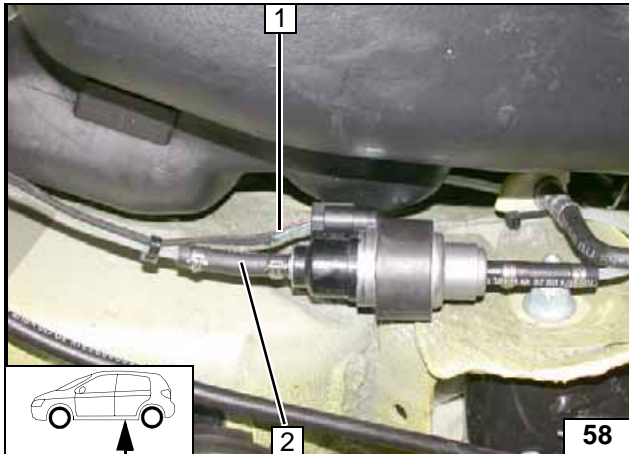

- 1 Wiring harness of metering pump, connector mounted
- 2 Fuel line, hose section, 10 mm dia. clamp [2x]

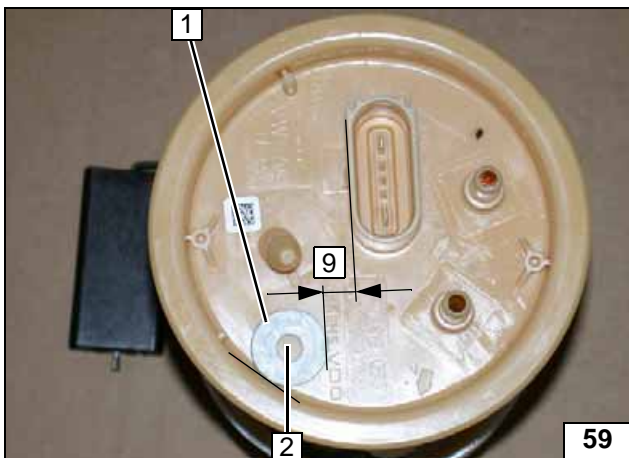

Remove fuel-tank sending unit **3** in accordance with manufacturer's instructions. Place washer **1** with outer dia.  $d_a = 17.6$  mm as shown.

- 2 Copy hole pattern, 6 mm dia. hole

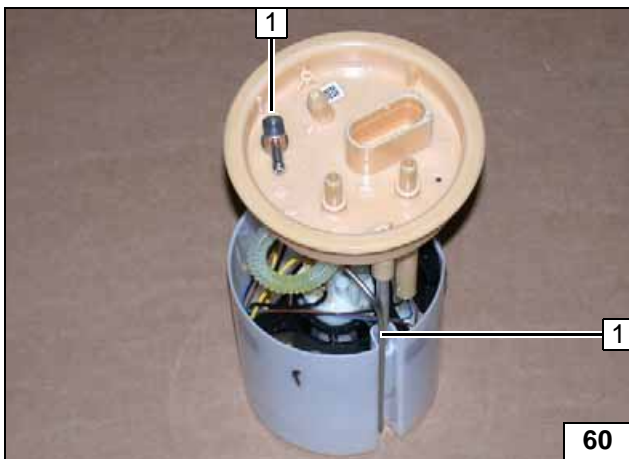

Shape fuel standpipe **1** according to template and cut to length.

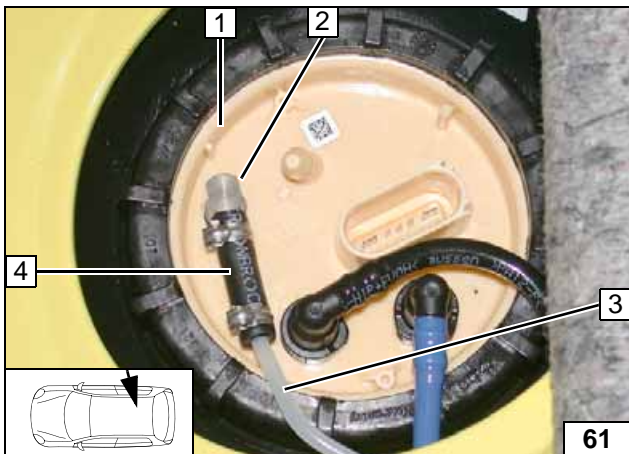

Install fuel-tank sending unit **1** in accordance with manufacturer's instructions.

- 2 Fuel standpipe
- 3 Fuel line
- 4 Hose section, 10 mm dia. clamp [2x]

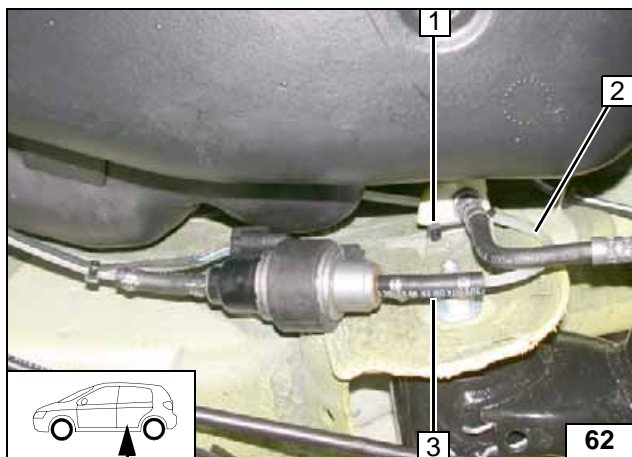

- 1 Cable tie
- 2 Fuel line
- 3 Hose section, 10 mm dia. clamp [2x]

**Connect-  
ing meter-  
ing pump**



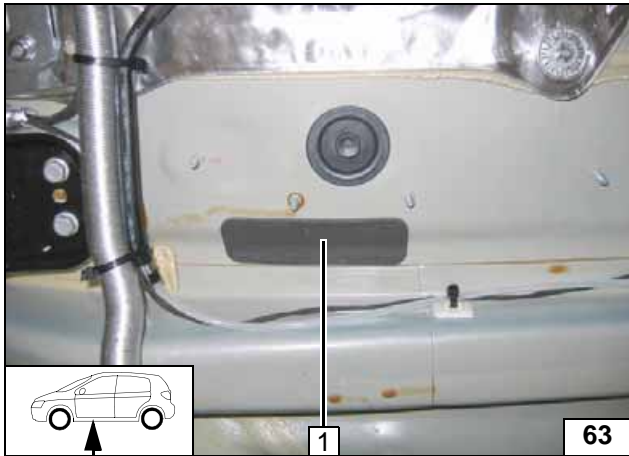
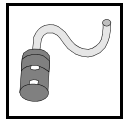

### Combustion Air

Glue insulation strips **1** as shown.



**Premounting bracket**

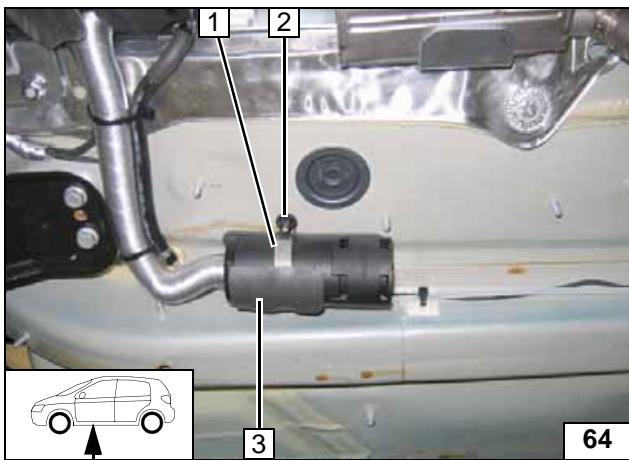

Glue insulation strips **3** as shown.

- 1** 51 mm dia. p-clamp
- 2** Plastic nut, original vehicle stud bolt



**Premounting heater**





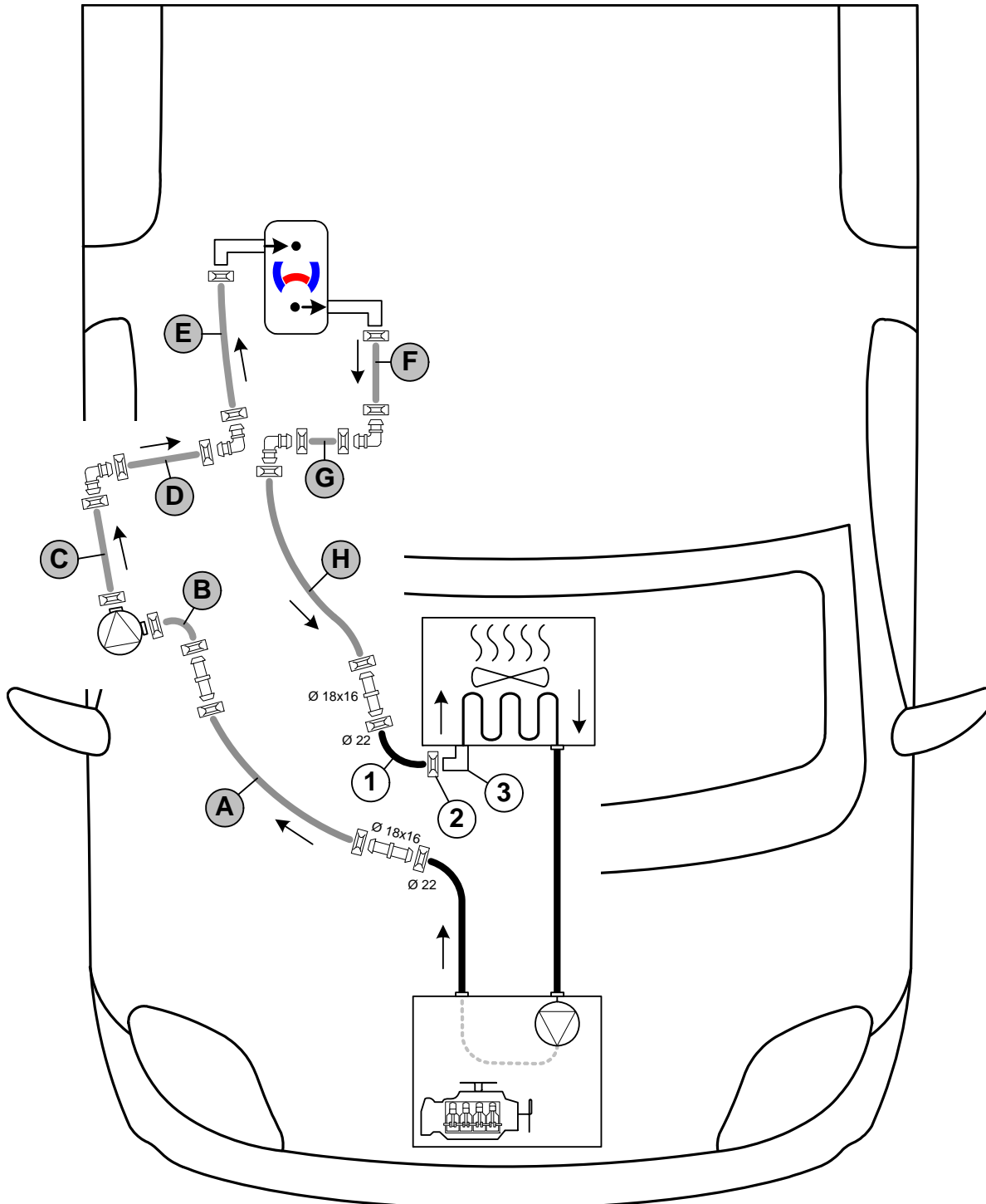

## Coolant Circuit

### WARNING!

Any coolant running off should be collected using an appropriate container. Install hoses so that they are kink-free. Unless specified otherwise, always fasten using cable ties. Position clamps so that no other hose can be damaged! When installing the hoses, the heater must be filled with coolant. The connection should be modelled on an "inline" circuit and based on the following diagram:



Hose routing diagram

All spring clips without a specific designation  = 25 mm dia. **1** = Original vehicle hose section.  
**2** = Original vehicle spring clip . **3** = original vehicle quick-release coupling!  
 All connecting pipes without a specific designation  and  = 18x18mm dia.



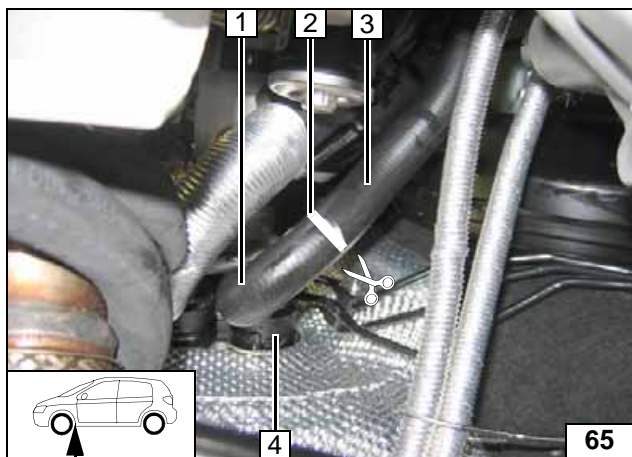

**1.2 TDI**

Detach original vehicle quick-release coupling 4 at connection piece.

- 1 Hose section of heat exchanger inlet
- 2 Cutting point
- 3 Engine outlet hose section

**Cutting point**

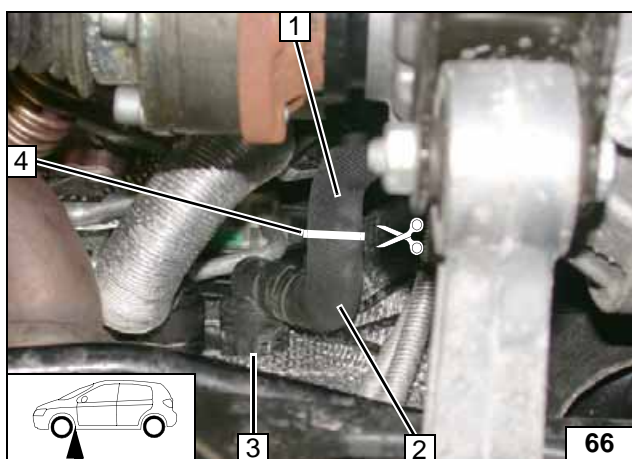

**1.6 TDI**

Detach original vehicle quick-release coupling 3 at connection piece.

- 1 Engine outlet hose section
- 2 Hose section of heat exchanger inlet
- 4 Cutting point

**Cutting point**

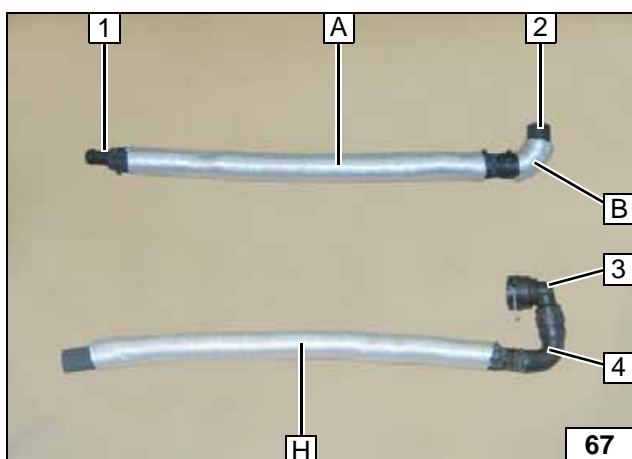

**All vehicles**

Install original vehicle hose section 4 as shown on original vehicle quick-release coupling 3.

- 1 Connection of engine outlet
- 2 Connection of circulating pump

**Preparing hoses**

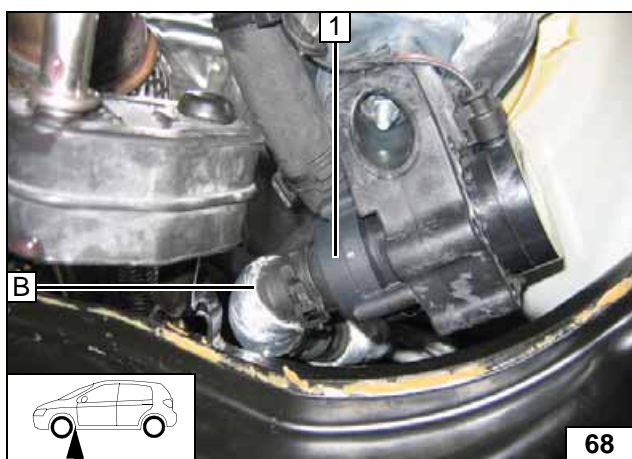

- 1 Circulating pump

**Connecting heater**

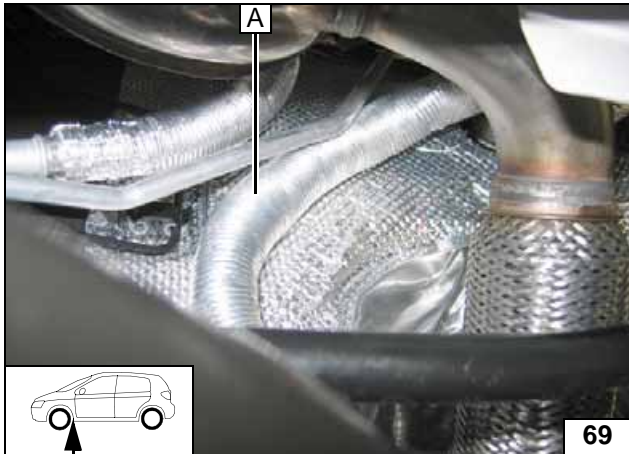

Routing in engine compartment

1 Engine outlet hose section

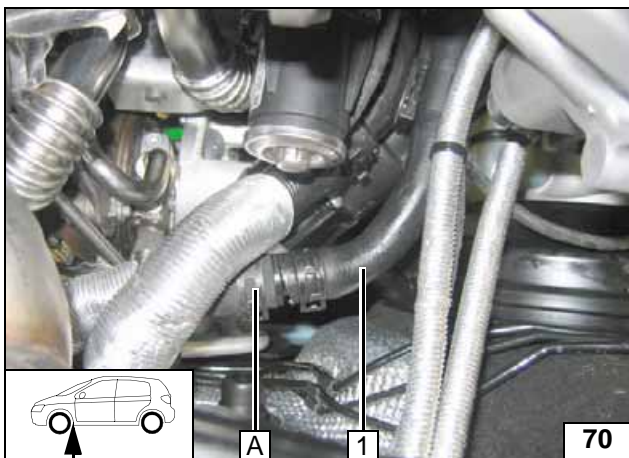

Connecting engine outlet

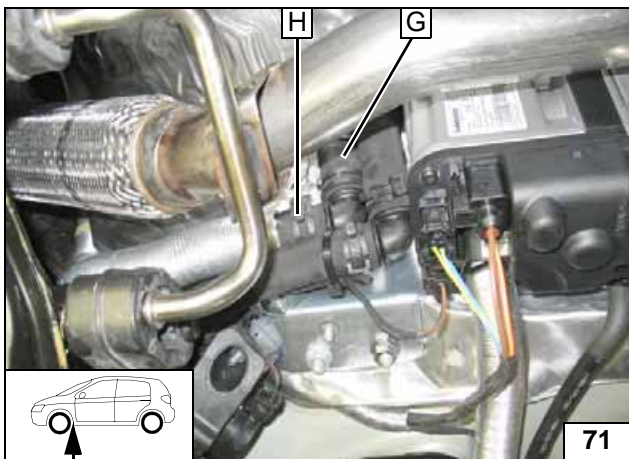

Connecting heater

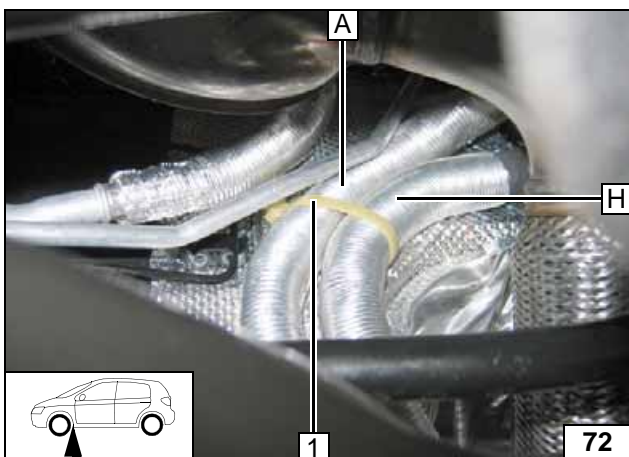

Ensure sufficient distance from neighbouring components.

1 Cable tie (temperature resistant)



Routing in engine compartment

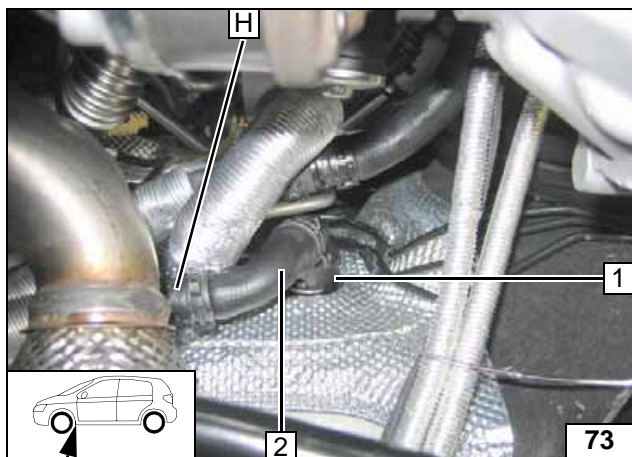
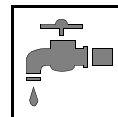

- 1 Original vehicle quick-release coupling at heat exchanger inlet
- 2 Original vehicle hose section.

Connect-  
ing heat ex-  
changer  
inlet



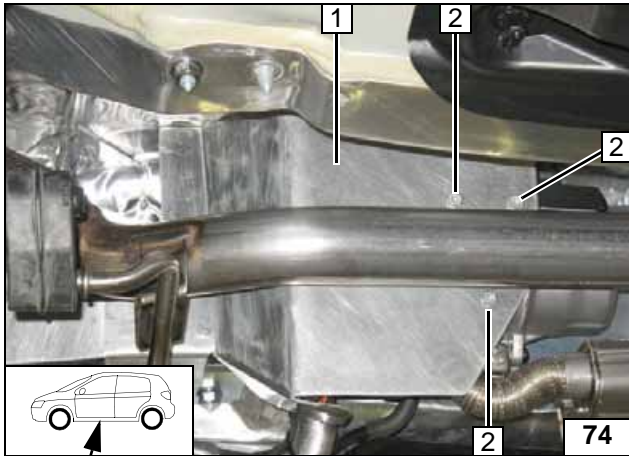

### Guard Plate

- 1 Guard plate
- 2 5x13 self-tapping bolt [3x]

Installing guard plate

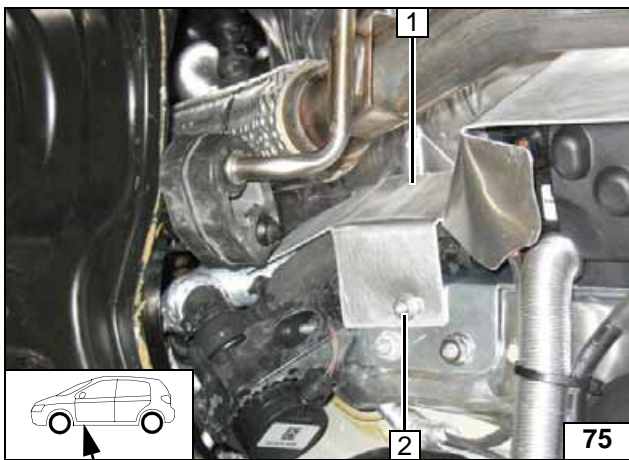

- 1 Guard plate
- 2 Flanged nut on M6x12 bolt

Installing guard plate

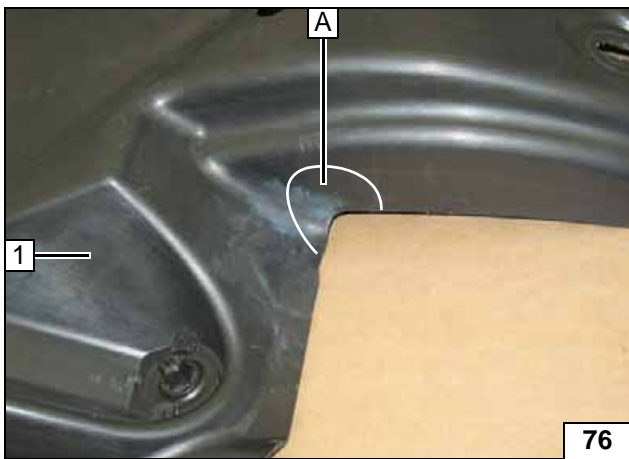

### Underbody Trim

Cut out underbody trim 1.

A Cutout



Cutting out underbody trim

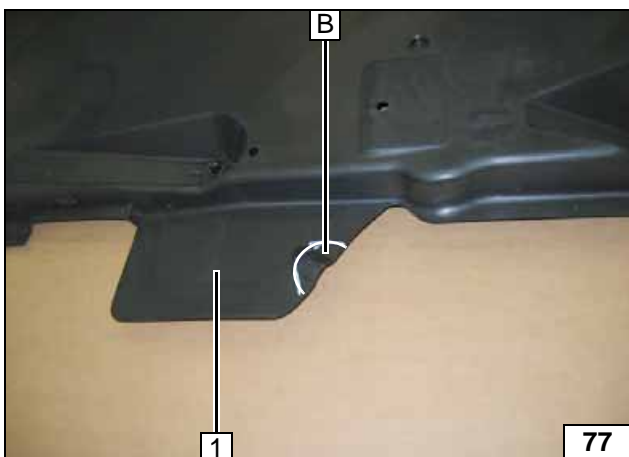

Cut out underbody trim 1.

B Cutout



Cutting out underbody trim



## Final Work

### WARNING!

Reassemble the disassembled components in reverse order. Check all hoses, clamps and all electrical connections for firm seating. Insulate all loose wires and tie back. Only use manufacturer-approved coolant. Spray heater components with anti-corrosion wax (Tectyl 100K, Order No. 111329).



- **Connect the battery.**
- **Fill and bleed the coolant circuit according to the vehicle manufacturer's specifications.**
- **Adjust digital timer, teach Telestart transmitter.**
- **Make settings on A/C control panel according to the "Operating Instructions for End Customer".**
- **Place caution label "Switch off parking heater before refuelling" in the area of the filler neck**
- **For initial start-up and function test, refer to installation instructions**



Install underbody cover **1**.  
Ensure sufficient distance from neighbouring components.

- A** Cutout for exhaust outlet
- B** Cutout for combustion air pipe



**Underbody trim**

Webasto Thermo & Comfort SE  
Postfach 1410  
82199 Gilching  
Germany  
Internet: [www.webasto.com](http://www.webasto.com)  
Technical Extranet:  
<http://dealers.webasto.com>

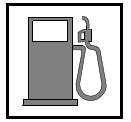

Template for Fuel Standpipe

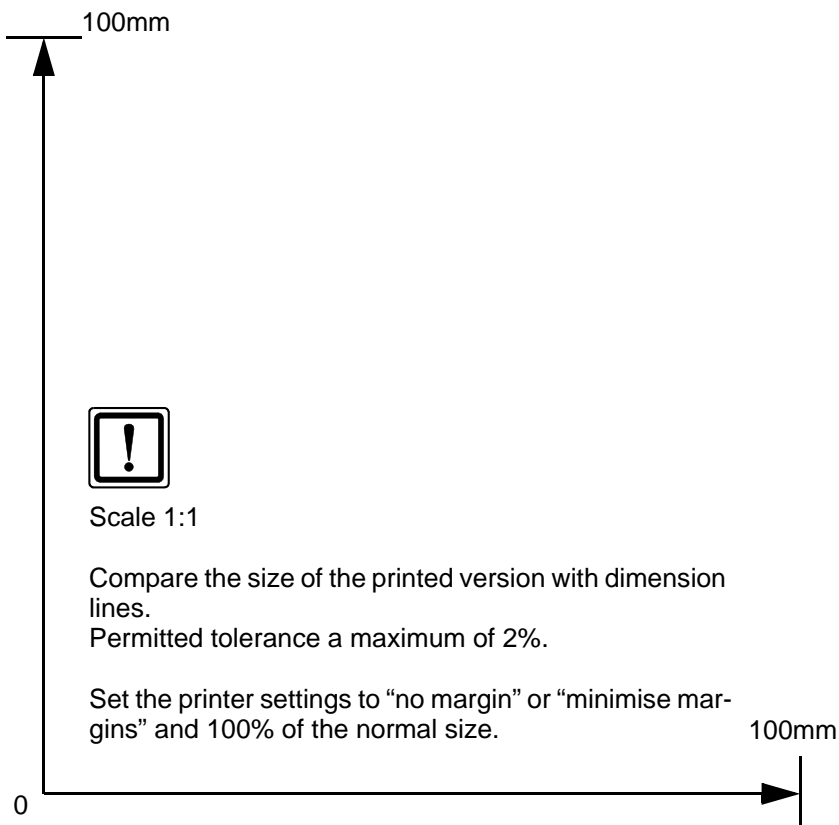
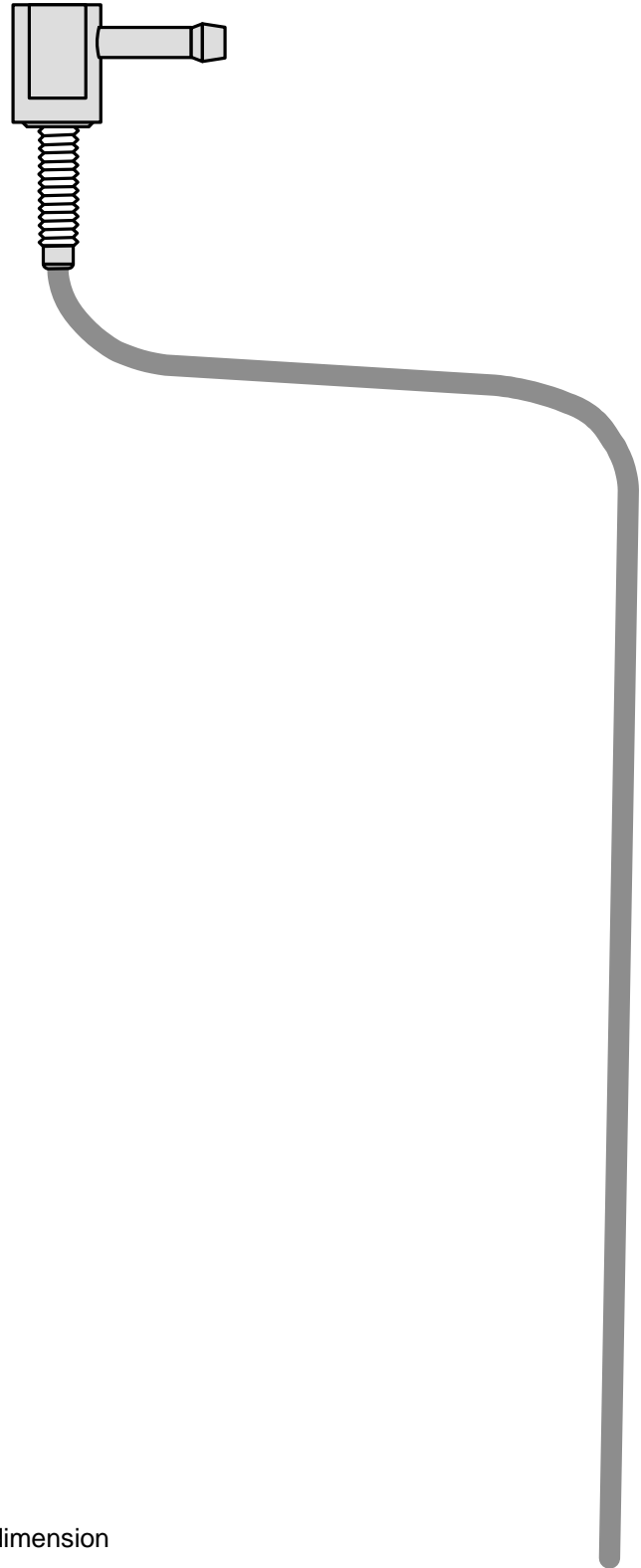





Template for Bracket

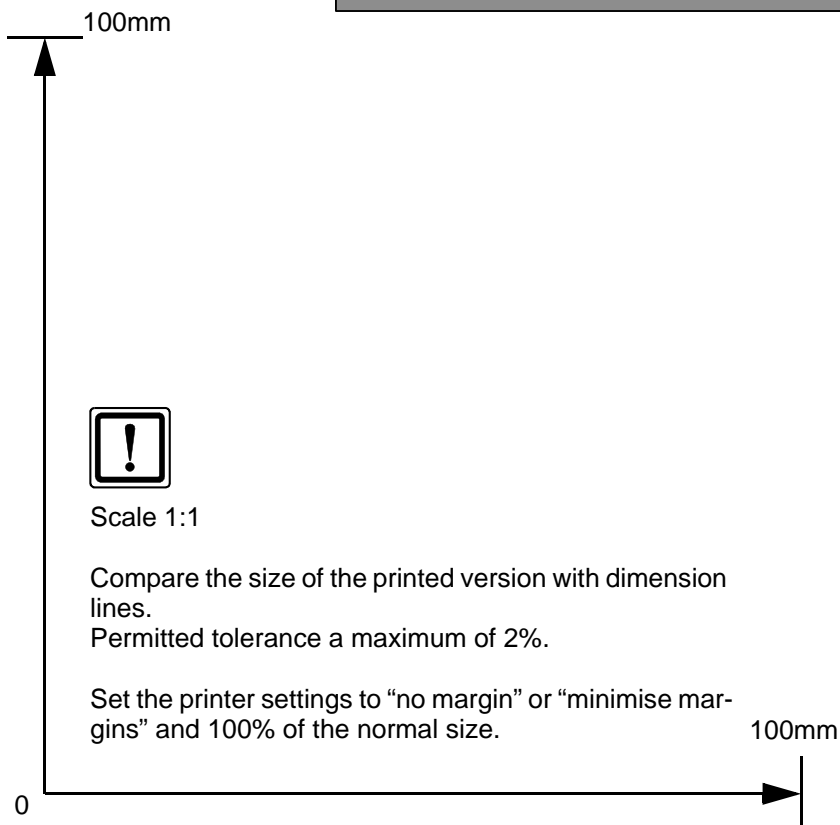
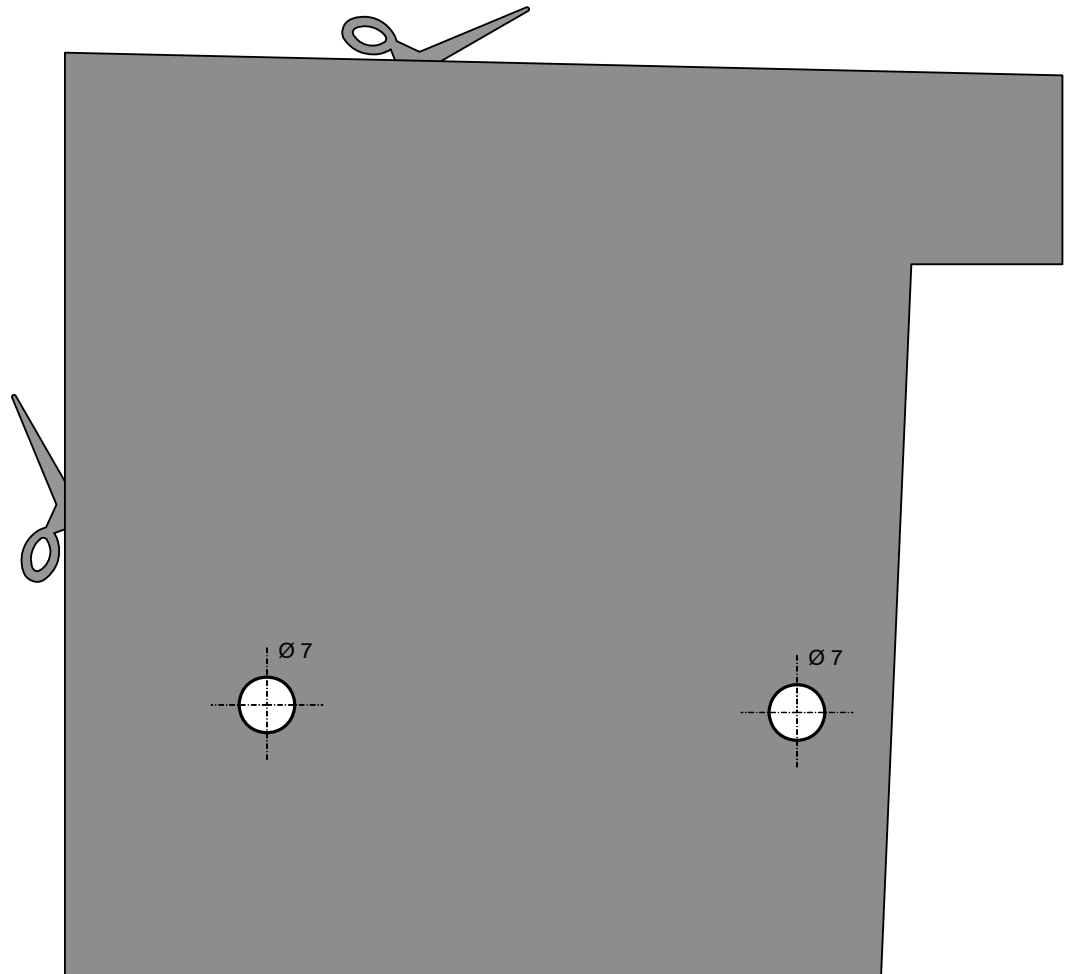

## Operating Instructions for Manual Air-Conditioning

Please remove page and add to the vehicle operating instructions.

**Note:**

We recommend matching the heating time to the driving time.  
Heating time = driving time

**Example:**

For a driving time of approx. 20 min. (in one direction), we recommend not exceeding a switch-on time of 20 min.

Passenger compartment monitoring, if installed, must be deactivated in addition to the vehicle settings for the heating operation.

For information on deactivation, please see the vehicle owner's manual.

Before parking the vehicle, make the following settings:



- 1 Set temperature to "max."
- 2 Set fan to level "1", max. "2"
- 3 Direct air outlet towards windscreen



**A/C control panel**

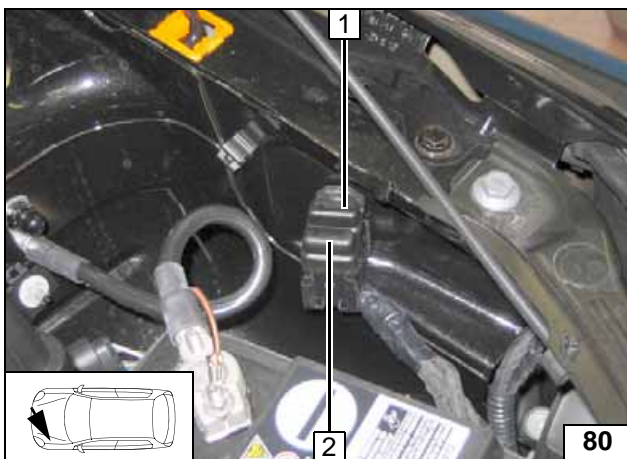

- 1 30A main fuse F2 of passenger compartment
- 2 20A heater fuse F1

**Engine compartment fuses**

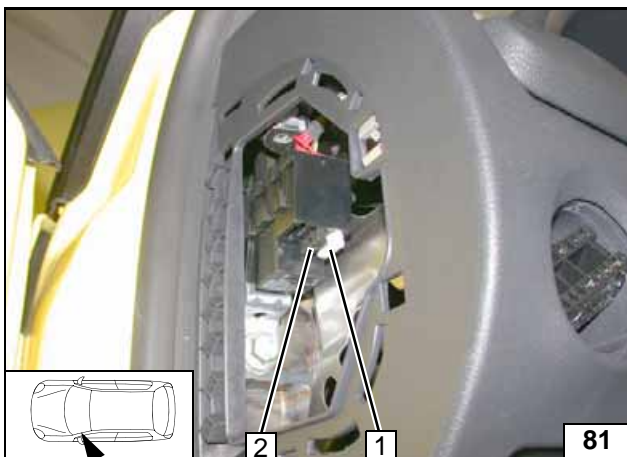

- 1 25A fan fuse F4
- 2 1A fuse F3 of heater control

**Passenger compartment fuses**



## Operating Instructions for Automatic Air-Conditioning

Please remove page and add to the vehicle operating instructions.

**Note:**

We recommend matching the heating time to the driving time.  
Heating time = driving time

**Example:**

For a driving time of approx. 20 min. (in one direction), we recommend not exceeding a switch-on time of 20 min.

Passenger compartment monitoring, if installed, must be deactivated in addition to the vehicle settings for the heating operation.

For information on deactivation, please see the vehicle owner's manual.

Before parking the vehicle, make the following settings:

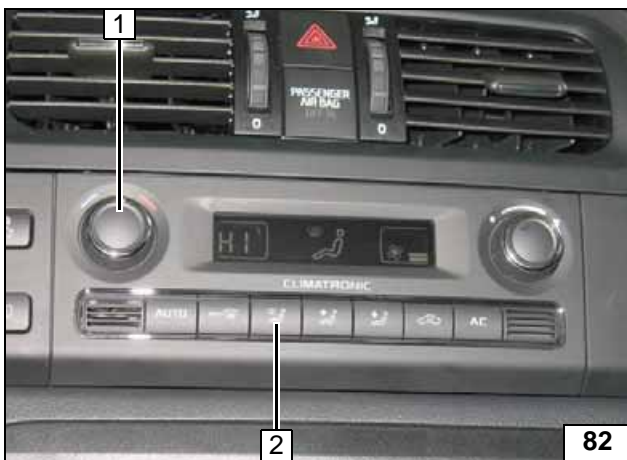

No need to pre-select the fan speed.

- 1 Direct air outlet towards windscreen
- 2 Set temperature to "HI"



**A/C control panel**

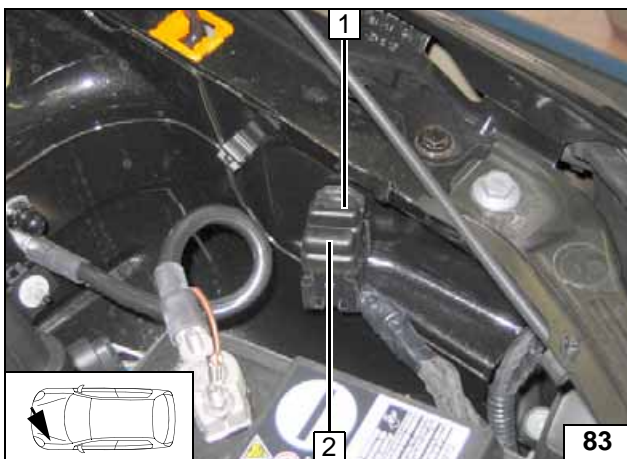

- 1 30A main fuse F2 of passenger compartment
- 2 20A heater fuse F1

**Engine compartment fuses**

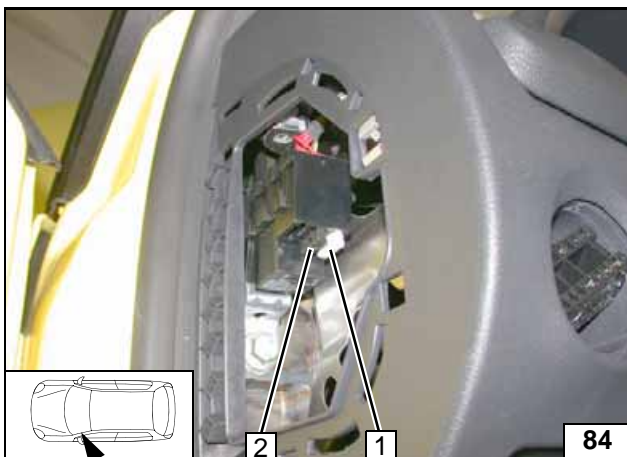

- 1 25A fan fuse F4
- 2 1A fuse F3 of heater control

**Passenger compartment fuses**