

# Water Heater

## Thermo Top Evo Parking Heater



# Installation Documentation

## Audi A1 / A1 Sportback

### Validity

Manufacturer	Model	Type	EG-BE-No. / ABE
Audi	A1	8X	e1 * 2007 / 46 * 0414 * ...
Audi	A1 Sportback	8X	e1 * 2007 / 46 * 0414 * ...

Motorisation	Fuel	Transmission type	Output in kW	Displacement in cm <sup>3</sup>	Engine code
1.6 TDI	Diesel - CR	SG	66	1598	CAYB
1.6 TDI	Diesel - CR	SG	77	1598	CAYC

SG = manual transmission

from Model Year 2010

Left-hand drive vehicle

**Verified equipment variants:** Manual / automatic air-conditioning system

Front fog light  
 Start-Stop  
 Daytime running lights

**Not verified:** Passenger compartment monitoring  
 Automatic transmission  
 Headlight washer system

**Necessary time for complete installation:** about 8 hours

# Audi A1 / A1 Sportback

## Table of Contents

Validity	1	Preparing Installation Location	14
Necessary Components	2	Preparing Heater	15
Installation Overview	2	Installing Heater	19
Information on Total Installation Time	2	Fuel	20
Information on Operating and Installation Instructions	3	Combustion Air	23
Information on Validity	4	Coolant Circuit	24
Technical Instructions	4	Guard Plate	27
Explanatory Notes on Document	4	Underbody Trim	27
Preliminary Work	5	Final Work	28
Heater Installation Location	5	Template for Bracket	29
Preparing Electrical System	6	Operating Instructions for Manual A/C System	31
Electrical System	8	Operating Instructions for Automatic A/C	32
Fan Controller Manual Air-Conditioning System	9		
Automatic Air-Conditioning Fan Controller	11		
Remote Option (Telestart)	13		

## Necessary Components

- *Thermo Top Evo* basic delivery scope in accordance with the price list
- Installation kit for Audi A1 / A1 Sportback 2010 TDI Common Rail: **1316695A**
- Automatic air-conditioning kit additional in case of automatic air-conditioning **1316697B**
- Heater control in accordance with price list and upon consultation with final customer
- In case of Telestart, Indicator lamp in accordance with price list and upon consultation with final customer

## Installation Overview

### Legend:

1. Heater
2. Fuse holder of engine compartment
3. Fuse holder of passenger compartment
4. Circulating pump
5. Digital timer
6. Metering pump

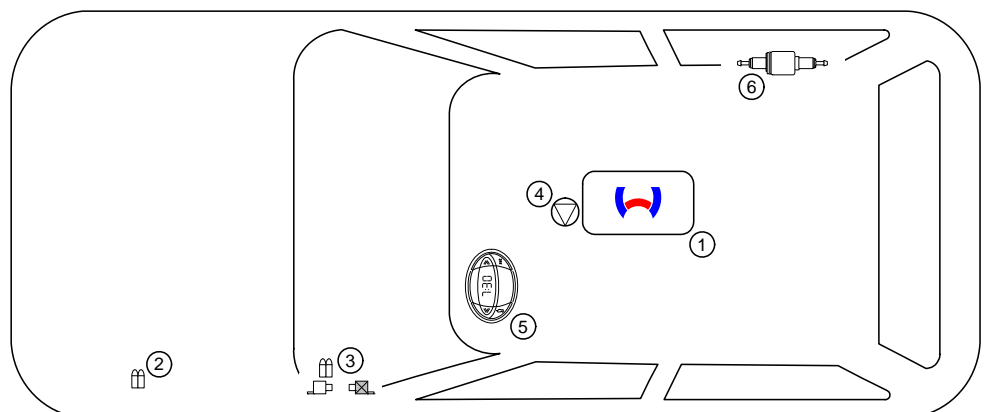

## Information on Total Installation Time

The total installation time includes the time needed for mounting and demounting of the vehicle-specific components, the heater specific installation time and all other times required for the system integration and initial start-up of the heater.

The total installation time may vary for vehicle equipment other than provided.

## Information on Operating and Installation Instructions

### 1 Important Information (not complete)

#### 1.1 Installation and Repair



The improper installation or repair of Webasto heating and cooling systems can cause fire or the leakage of deadly carbon monoxide, leading to serious injury or death.



To install and repair Webasto heating and cooling systems you need to have completed a special company training course and have the appropriate technical documentation, special tools and special equipment.



Installation and repair may ONLY be carried out by persons trained and certified in a Webasto training course. NEVER try to install or repair Webasto heating or cooling systems if you have not completed a Webasto training course, you do not have the necessary technical skills and you do not have the technical documentation, tools and equipment available to ensure that you can complete the installation and repair work properly.

Only use genuine Webasto parts. See the Webasto air and water heaters accessories catalogue for this purpose.

#### 1.2 Operation

To ensure safe operation, we recommend having the heater checked every two years by an authorised Webasto dealer, especially when used over a long period and/or under extreme environmental conditions.

Do not operate the heater in closed rooms due to the danger of poisoning and suffocation.

Always switch off the heater before refuelling.

The heater may only be used with the prescribed fuel Diesel (DIN EN 590) or petrol (DIN EN 227).

The heater may not be cleaned with a high-pressure cleaner.

#### 1.3 Please note

ALWAYS follow all Webasto installation and operating instructions and observe all warnings.

To become familiar with and understand all functions and properties of the heater, the operating instructions must be read carefully and observed at all times.

For proper, safe installation and repair work, the installation instructions with all warnings and safety information must be carefully read and observed at all times. Please always contact a workshop authorised by Webasto for all installation and repair work.

### IMPORTANT

**Webasto shall assume no liability for defects, damage and injuries resulting from a failure to observe the installation, repair and operating instructions of the information contained in them.**

**This liability exclusion particularly applies to improper installations and repairs, installations and repairs by untrained persons or in the case of a failure to use genuine spare parts.**

**The liability due to culpable disregard to life, limb or health and due to damage or injuries caused by a wilful or reckless breach of duty remain unaffected, as does the obligatory product liability.**

**Installation should be carried out according to the general, standard rules of technology. Unless specified otherwise, fasten hoses, lines and wiring harnesses to original vehicle lines and wiring harnesses using cable ties. Insulate loose wire ends and tie back.**

**Sharp edges should be fitted with rub protection (split-open fuel hose)! Spray unfinished body areas, e.g. drilled holes, with anti-corrosion wax (Tectyl 100K, Order No. 111329).**

**Observe the instructions and guidelines of the respective vehicle manufacturer for demounting and mounting vehicle specific components!**

**The initial startup is to be executed with the Webasto Thermo Test Diagnosis.**

**When installing an IPCU, the corresponding settings must be checked or adjusted before the installation.**

### 2 Statutory regulations governing installation

Guidelines	Thermo Top Evo
Heating Directive ECE R122	E1 00 0258
EMC Directive ECE R10	E1 03 5627

### NOTE

The regulations of these guidelines are binding in the scope of the Directive 70/156/EEC and/or 2007/46/EC (for new vehicle models from 29/04/2009) and should also be observed in countries in which there are no special regulations.

### IMPORTANT

Failure to follow the installation instructions will result in the invalidation of the type approval for the heater and therefore invalidation of the general **homologation of the vehicle**.

### NOTE

For vehicles with an EU permit, no entry in accordance with § 19 Sub-Section 4 of Annex VIII b to the Road Traffic Act is required.

#### 2.1 Excerpt from the directive 2001/56/EC Appendix VII for the installation of the heater

Beginning of excerpt.

### ANNEX VII

#### REQUIREMENTS FOR COMBUSTION HEATERS AND THEIR INSTALLATION

##### 1. GENERAL REQUIREMENTS

1.1.1. A clearly visible tell-tale in the operator's field of view shall inform when the combustion heater is switched on or off.

##### 2. VEHICLE INSTALLATION REQUIREMENTS

###### 2.1. Scope

2.1.1. Subject to paragraph 2.1.2. combustion heaters shall be installed according to the requirements of this Annex.

2.1.2. Vehicles of category O having liquid fuel heaters are deemed to comply with the requirements of this Annex.

###### 2.2. Positioning of heater

2.2.1. Body sections and any other components in the vicinity of the heater must be protected from excessive heat and the possibility of fuel or oil contamination.

2.2.2. The combustion heater shall not constitute a risk of fire, even in the case of overheating. This requirement shall be deemed to be fulfilled if the installation ensures an adequate distance to all parts and suitable ventilation, by the use of fire resistant materials or by the use of heat shields.

2.2.3. In the case of M2 and M3 vehicles, the heater must not be positioned in the passenger compartment. However, an installation in an effectively sealed envelope which also complies with the conditions in paragraph 2.2.2 may be used.

2.2.4. The label referred to in paragraph 1.4 or a duplicate, must be positioned so that it can be easily read when the heater is installed in the vehicle.

2.2.5. Every reasonable precaution should be taken in positioning the heater to minimise the risk of injury and damage to personal property.

###### 2.3. Fuel supply

2.3.1. The fuel filler must not be situated in the passenger compartment and must be provided with an effective cap to prevent fuel spillage.

2.3.2. In the case of liquid fuel heaters, where a supply separate to that of the vehicle is provided, the type of fuel and its filler point must be clearly labelled.

2.3.3. A notice, indicating that the heater must be shut down before refuelling, must be affixed to the fuelling point. In addition a suitable instruction must be included in the manufacturer's operating manual.

###### 2.4. Exhaust system

2.4.1. The exhaust outlet must be located so as to prevent emissions from entering the vehicle through ventilators, heated air inlets or opening windows.

###### 2.5. Combustion air inlet

2.5.1. The air for the combustion chamber of the heater must not be drawn from the passenger compartment of the vehicle.

2.5.2. The air inlet must be so positioned or guarded that blocking by rubbish or luggage is unlikely.

###### 2.6. Heating air inlet

2.6.1. The heating air supply may be fresh or recirculated air and must be drawn from a clean area not likely to be contaminated by exhaust fumes emitted either by the propulsion engine, the combustion heater or any other vehicle source.

2.6.2. The inlet duct must be protected by mesh or other suitable means.

###### 2.7. Heating air outlet

2.7.1. Any ducting used to route the hot air through the vehicle must be so positioned or protected that no injury or damage could be caused if it were to be touched.

2.7.2. The air outlet must be so positioned or guarded that blocking by rubbish or luggage is unlikely.

End of excerpt.

In multilingual versions the German language is binding.

# Audi A1 / A1 Sportback

## Information on Validity

This installation documentation applies to Audi A1 / A1 Sportback Diesel vehicles - for validity, see page 1 - from model year 2010 and later, assuming technical modifications to the vehicle do not affect installation, any liability claims excluded. Depending on the vehicle version and equipment, modifications may be necessary during installation with respect to this installation documentation.

Vehicle and engine types, equipment variants and other specifications not listed in this installation documentation have not been tested. However, installation according to this installation documentation may be possible.

## Technical Instructions

### Special Tools

- Hose clamp pliers for self-clamping hose clamps
- Hose clamp pliers for Clic hose clamps of type W
- Automatic wire stripper 0.2 - 6mm<sup>2</sup>
- Crimping pliers for cable lug / tab connector 0.5 - 6mm<sup>2</sup>
- Torque wrench for 2.0 - 10 Nm
- Hose clamping pliers
- Webasto Thermo Test diagnosis with current software

### Measurements

- All measurements are in mm!

### Tightening torque values

- Tightening torque values of heater bolts and 5x13 heater stud bolts = 8Nm.
- Tightening torque values of 5x15 retaining plate and water connection piece bolts = 7Nm.
- Tighten other screw connections in accordance with manufacturer's instructions or in accordance with state-of-the-art-technology.

## Explanatory Notes on Document

You will find an identification mark on the outside top right corner of the page in question to provide you with a quick overview of the individual working steps.

Special features are highlighted using the following symbols:

### Mechanical system



### Electrical system



### Coolant circuit

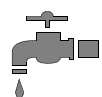

### Combustion air



### Fuel



### Exhaust gas



### Software



### Specific risk of injury or fatal accidents



### Specific risk of damage to components



### Specific risk of fire and explosion



### Reference to general installation instructions of the Webasto components or to the manufacturer's vehicle-specific documents.



### Reference to a special technical feature



### The arrow in the vehicle icon indicates the position on the vehicle and the viewing angle

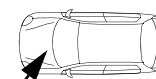
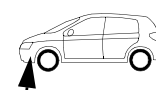

# Audi A1 / A1 Sportback

## Preliminary Work

### Vehicle

- Open the fuel tank cap.
- Ventilate the fuel tank.
- Close the fuel tank cap again.
- Depressurise the cooling system.
- Disconnect the battery.
- Drain the engine coolant according to the manufacturer's instructions.
- Remove the air filter together with the intake hose.
- Remove the engine control unit from the bracket.
- Remove the windscreen wipers.
- Remove the coolant reservoir cap.
- Remove the engine control unit bracket.
- Remove the sound insulation from the coolant reservoir partition wall.
- Remove the coolant reservoir partition wall.
- Remove the underride protection.
- Remove the right vehicle underbody trim.
- Remove the driver and front passenger seat.
- Remove the left and right entrance strip.
- Fold up the seating area of the rear bench seat and remove.
- Remove the centre tunnel cover.
- Remove the left and right lower A-pillar trim.
- Remove the floor covering.
- Remove the air duct for the rear footwell.
- Remove the left and right side panel of the instrument panel.
- Remove the glove compartment.
- Open the tank-fitting service lid.
- Remove the lower instrument panel trim on the driver's side.

### Heater

- Remove years that do not apply from the type and duplicate label.
- Attach the duplicate label (type label) visibly in the appropriate place in the engine compartment.

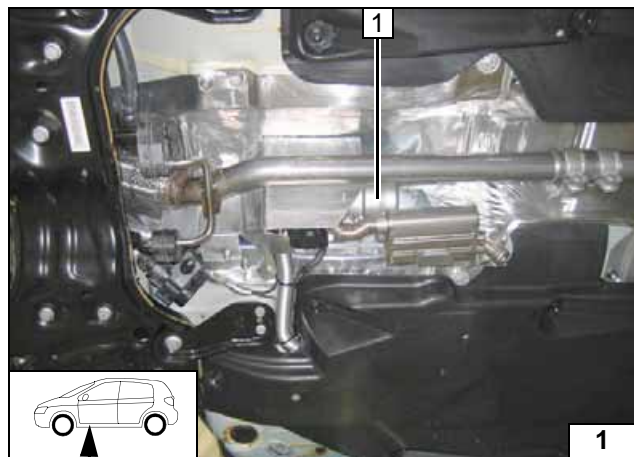

### Heater Installation Location

1 Heater

Installation location

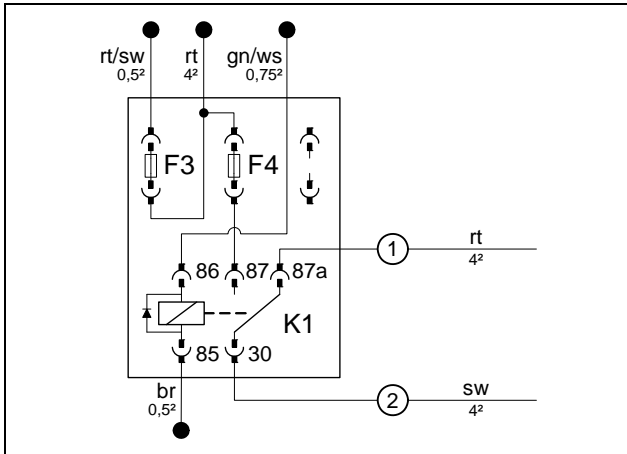

## Preparing Electrical System

### Manual air-conditioning system

F4 25A and K1-relay inserted. Insert red (rt) wire ① into K1/87a relay socket and insert black (sw) wire ② into K1/30 relay socket.



Preparing fuse carrier of passenger compartment

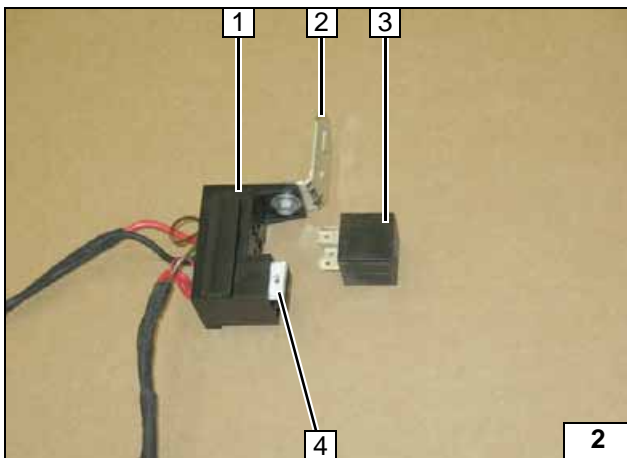

- 1 Passenger compartment fuse holder
- 2 Angle bracket, bolt M5x16, washer, nut
- 3 Plug relay K1 in relay socket after angle bracket assembly
- 4 25A fuse F4

Preparing fuse carrier of passenger compartment

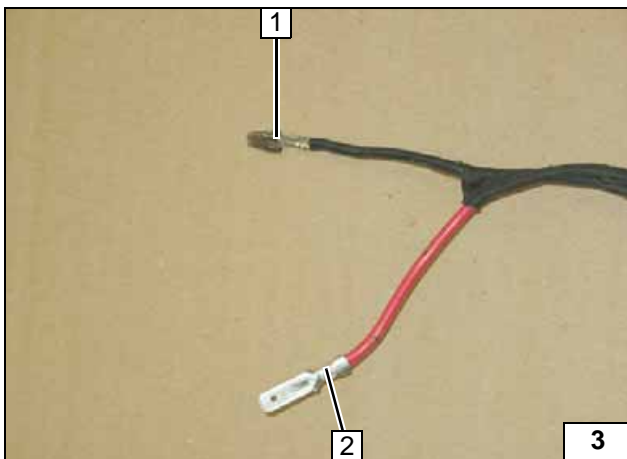

- 1 4² standard power timer, black (sw) wire ② K1/30
- 2 4² tab connector, red (rt) wire ① K1/87a



Preparing cable connection

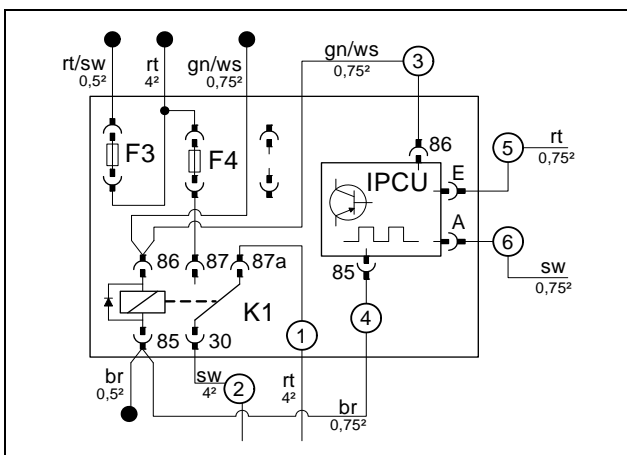

### Automatic air-conditioning

F4 25A and K1-relay inserted. Insert red (rt) wire ① into K1/87a relay socket and insert black (sw) wire ② into K1/30 relay socket. Insert green/white (gn/ws) wire ③ into IPCU/86 socket and connect it to K1/86 as well. Insert brown (br) wire ④ into IPCU/85 socket, insert red (rt) wire ⑤ into IPCU/E socket and black (sw) wire into IPCU/A ⑥ socket. Pull red (rt) wire ⑤ and black (sw) wire ⑥ into protective sleeving.



Preparing fuse carrier of passenger compartment

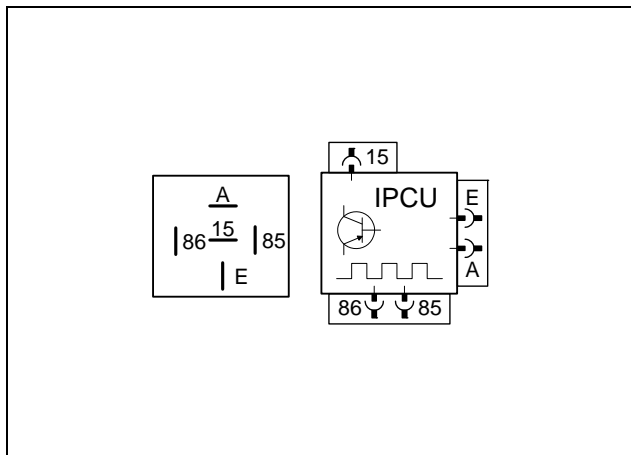

Connect wires to IPCU socket.  
View IPCU on contact side!  
The IPCU is pre-programmed with the following settings. These setting values must be checked during the function check on the vehicle and adjusted, if necessary.

Duty cycle: 100%  
Frequency: 1,000 Hz  
Voltage: 3.6V  
Function: High side



**Premounting IPCU**

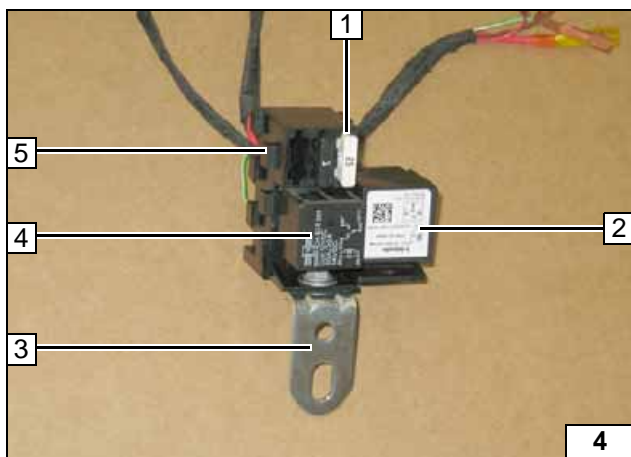

- 1 25A fuse F4
- 2 IPCU
- 3 Angle bracket, bolt M5x16, washer, nut
- 4 Relay K1
- 5 Passenger compartment fuse holder

**Preparing fuse carrier of passenger compartment**

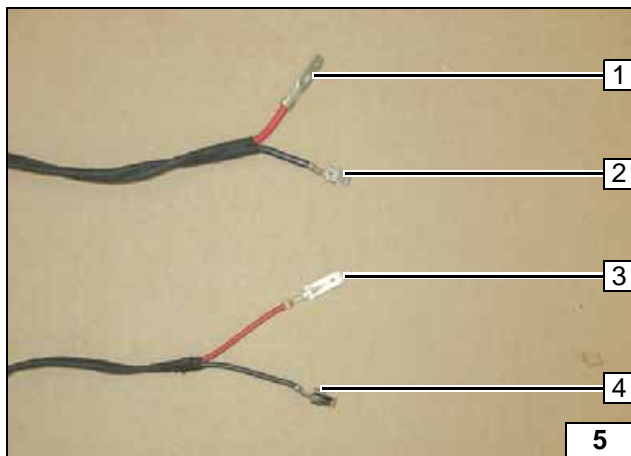

- 1 4<sup>2</sup> tab connector, red (rt) wire ① of K1/87A
- 2 4<sup>2</sup> standard power timer, black (sw) wire ② from K1/30
- 3 0,5-1<sup>2</sup> tab connector, red (rt) wire ⑤ from IPCU/E
- 4 0,5-1<sup>2</sup> standard power timer, black (sw) wire ⑥ from IPCU/A

**Preparing cable connection**

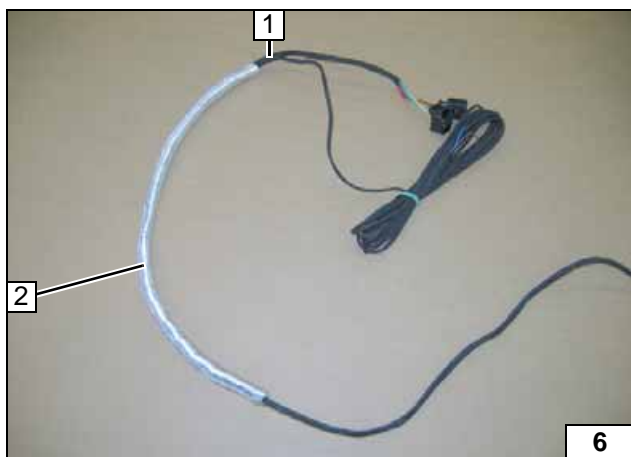

Slit 540 mm long protective pipe 2 longitudinally and pull onto wiring harness of heater 1.



**Pulling on protective pipe**



**Electrical System**

**Power supply connection**

- 1 Earth point, earth wire
- 2 Positive distributor, positive wire

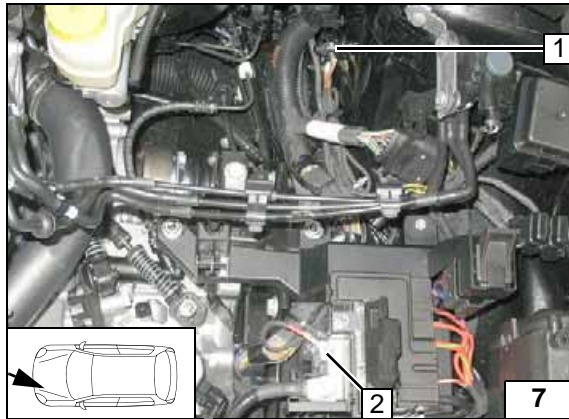

**Digital timer**

- 1 Digital timer

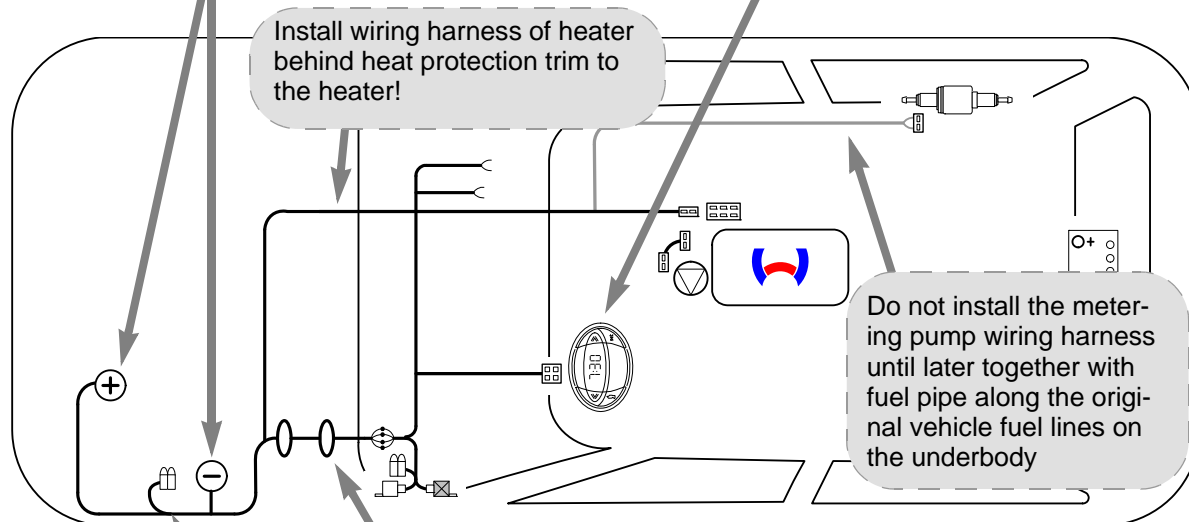
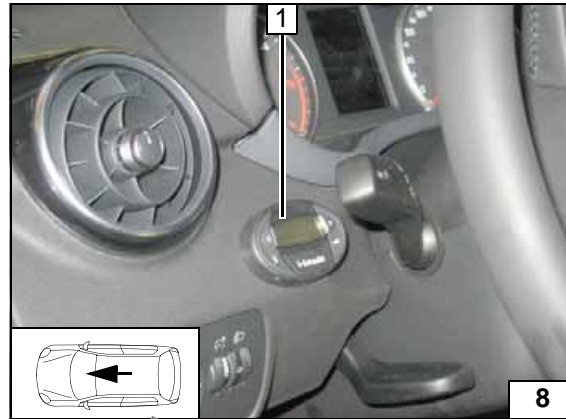

**Wiring harness routing diagram**

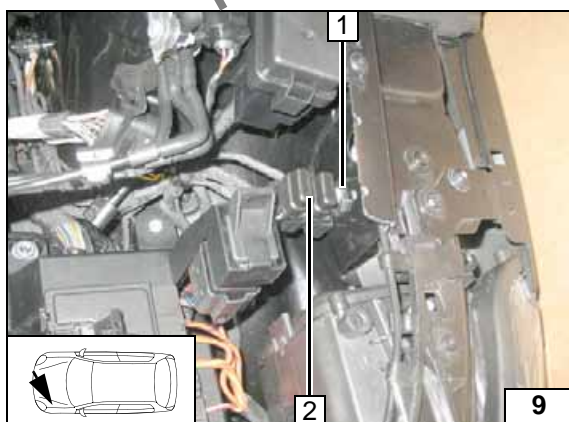

**Fuse holder engine compartment**

- 1 Hole dia. 4.5 mm; self-tapping screw 5.5x13; retaining plate, fuse holder
- 2 Fuses F1-2 inserted



**Wiring harness pass through of passenger compartment**

- 1 Protective rubber plug pass through, coolant reservoir
- 2 Wiring harness, fuse holder, engine compartment





Fan Controller Manual Air-Conditioning System

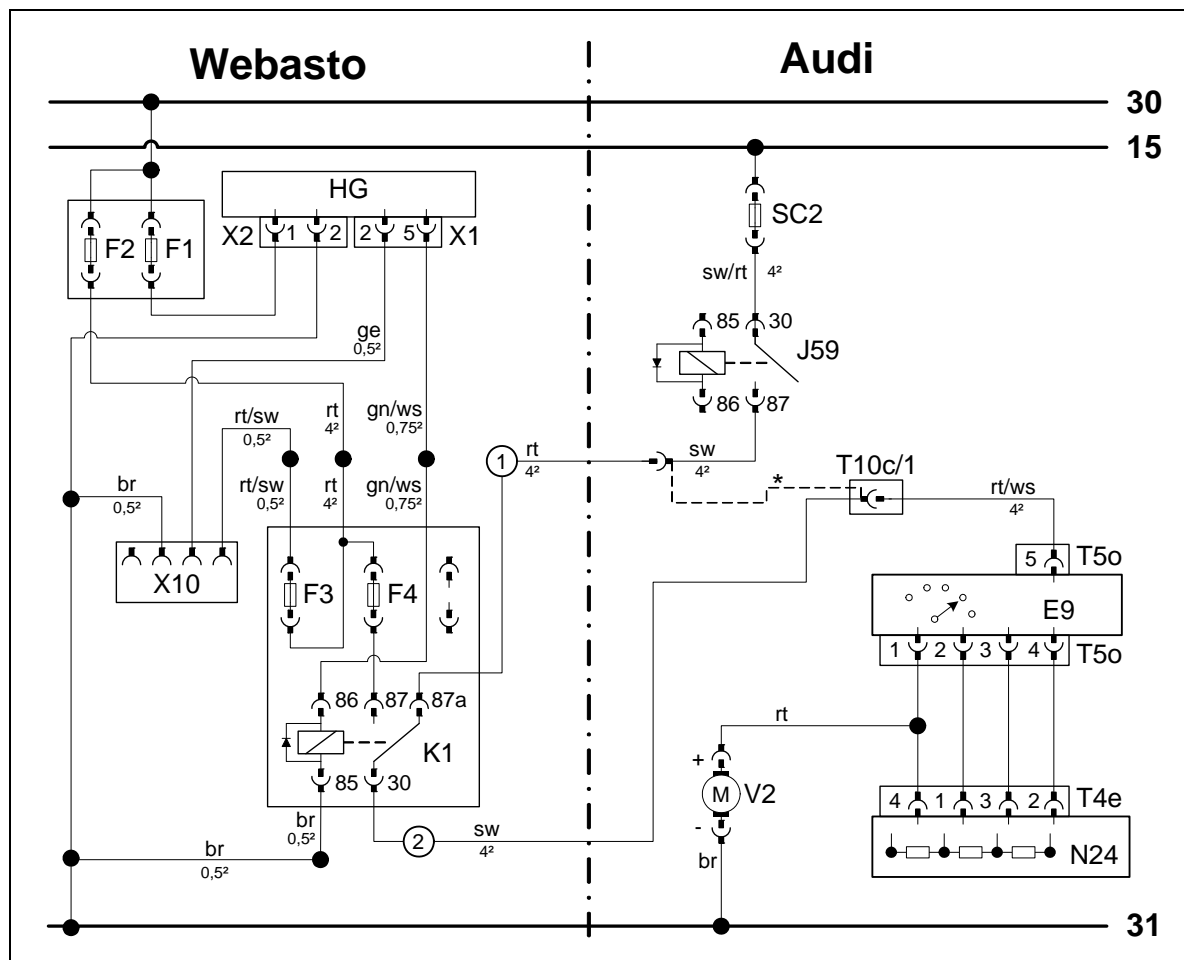

Wiring diagram

Webasto components		Vehicle components		Colours and symbols	
HG	Heater TT-Evo	V2	Fan motor	rt	red
X1	6-pin heater connector	SC2	Fuse 40A	ws	white
X2	2-pin heater connector	N24	Resistor group	sw	black
X10	4-pin connector Heater control	E9	Switch unit	br	brown
K1	Fan relay	T ...	Connector	gn	green
F1	Fuse 20A	J59	Relay X- contact		
F2	Fuse 30A				
F3	Fuse 1A			*	Original condition
F4	Fuse 25A				Wiring colours may vary.

Legend

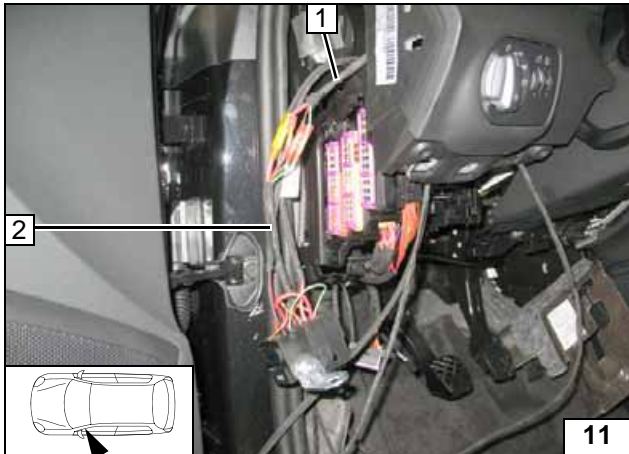

Connect the wiring harnesses of fuse holder in engine compartment **1** and passenger compartment **2** colour-matched according to wiring diagram!



**Connect-  
ing wiring  
harnesses**

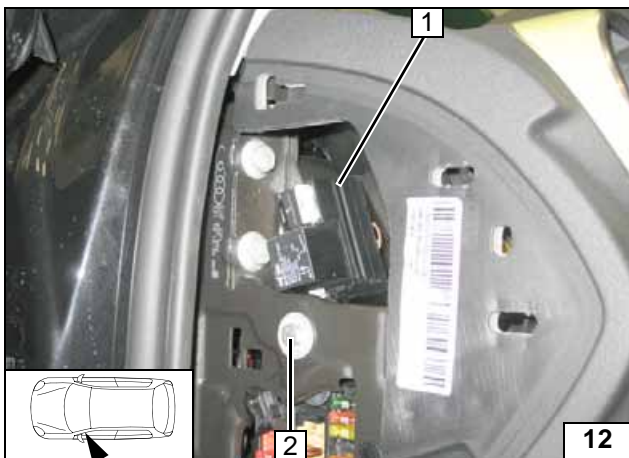

**1** Fuse holder, passenger compartment  
**2** M6x20 bolt, angle bracket, flanged nut, existing hole



**Assem-  
bling fuse  
holder in  
passenger  
compart-  
ment**



Remove connector T10c **1** from the bracket



**Connector  
T10c**

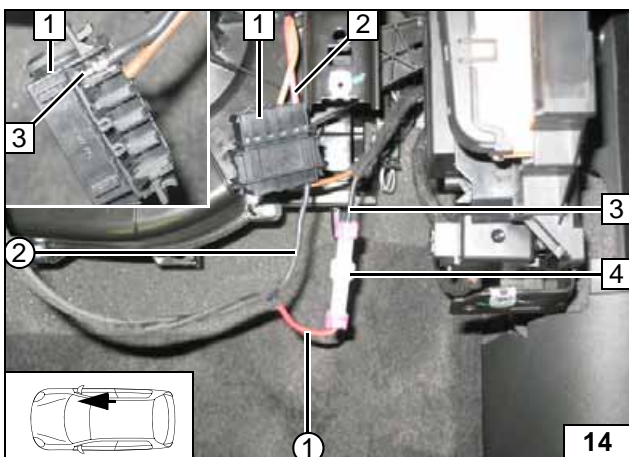

Produce connections as shown in wiring diagram.

Heed information sheet of replacement AMP plug connection.

Remove black (sw) wire **3** from connector **1** T10c/1!

- 1** Connector T10c
- 2** Red/white (rt/ws) wire of fan switch
- 3** Black (sw) wire of fuse SC2
- 4** Provide connector housing with rattle protection after the assembly
- ① Red (rt) wire from K1/87a
- ② Black (sw) wire K1/30 in connector T10c/1



**Connec-  
tion of cen-  
tral  
electrical  
box**



Automatic Air-Conditioning Fan Controller

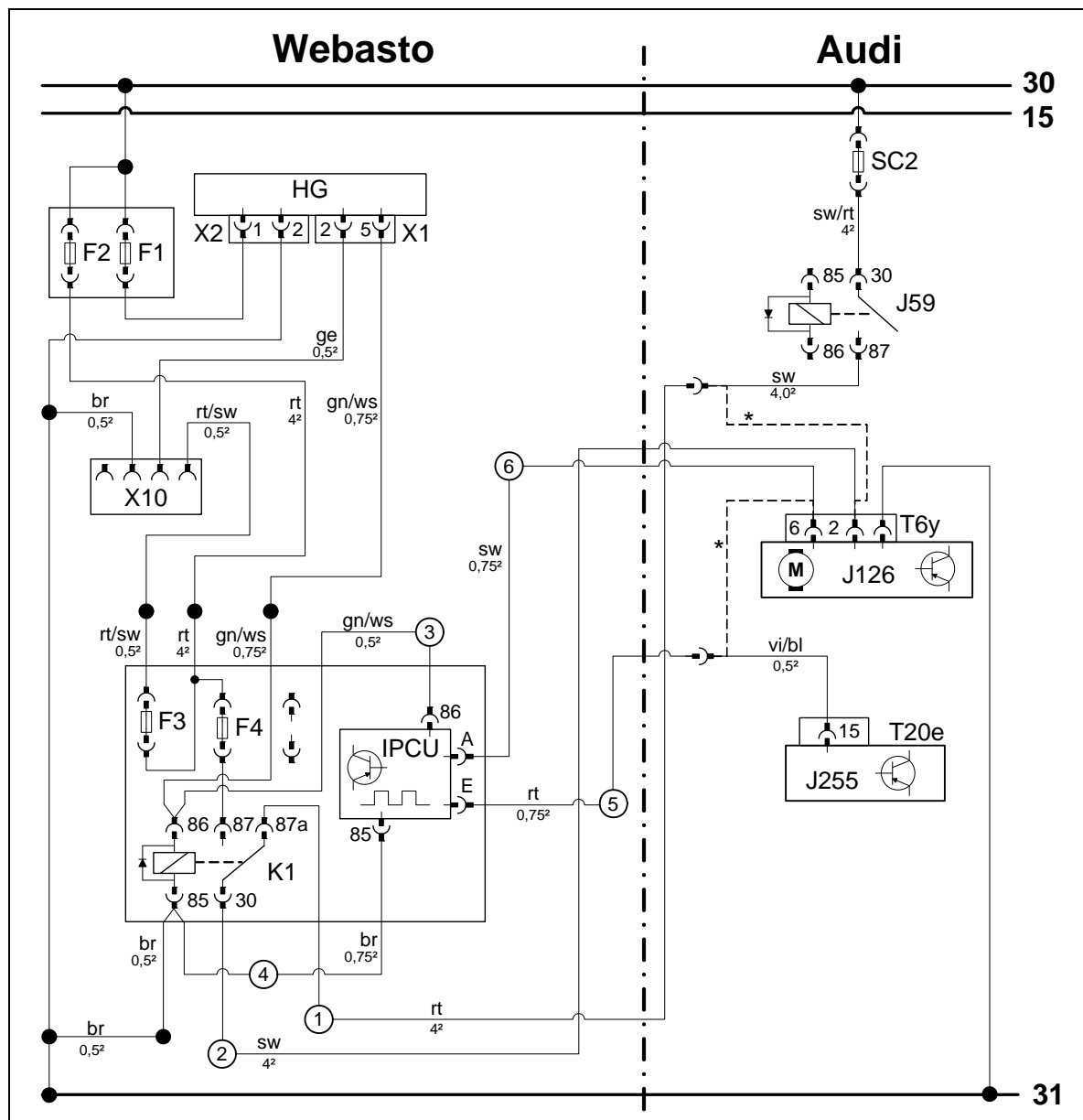

Wiring diagram

Webasto components		Vehicle components		Colours and symbols	
HG	Heater TT-Evo	J126	Fan unit	rt	red
X1	6-pin heater connector	J255	Air-conditioning control panel	ws	white
X2	2-pin heater connector	SC2	Fuse 40A	sw	black
X10	4-pin connector Heater control	T...	Connector	br	brown
K1	Fan relay	J59	Relay X- contact	bl	blue
F1	Fuse 20A			gn	green
F2	Fuse 30A			ge	yellow
F3	Fuse 1A			vi	violet
F4	Fuse 25A				
IPCU	Pulse width modulator				
<b>IPCU adjustment values</b>					
Voltage: 3.6 V					
Frequency: 1,000 Hz					
Duty cycle: 100 %					
Function: High side					
				*	Original condition
				Wiring colours may vary.	

Legend

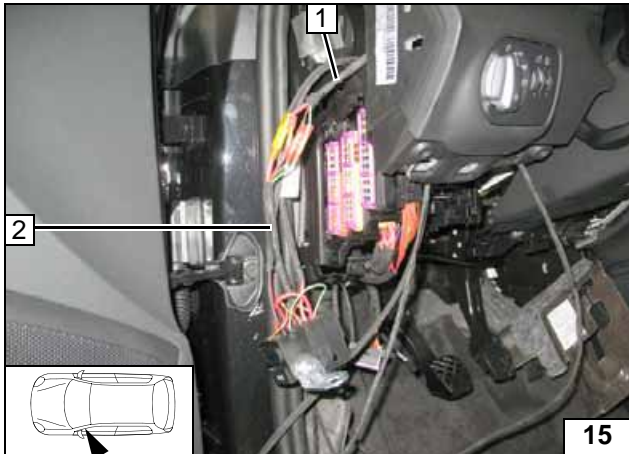

Connect the wiring harnesses of fuse holder in engine compartment **1** and passenger compartment **2** colour-matched according to wiring diagram!



**Connect-  
ing wiring  
harnesses**

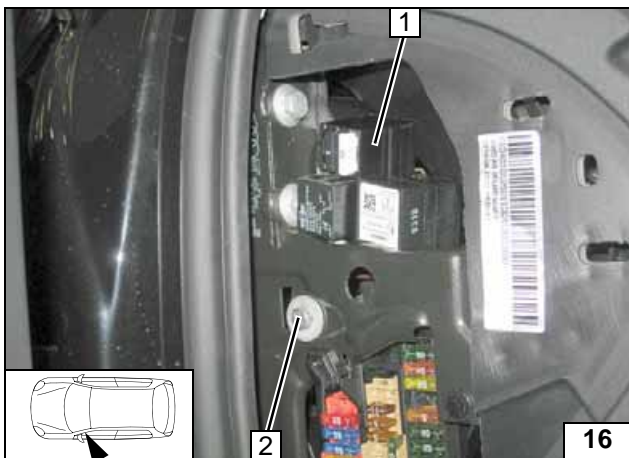

**1** Fuse holder, passenger compartment  
**2** M6x20 bolt, angle bracket, flanged nut, existing hole



**Assem-  
bling fuse  
holder in  
passenger  
compartment**

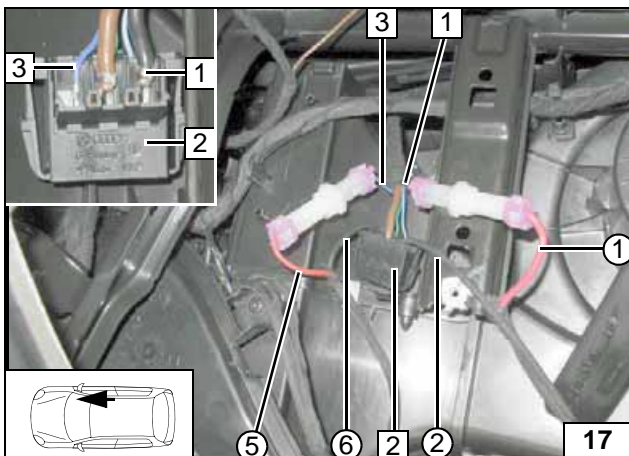

Produce connections as shown in wiring diagram.

Heed information sheet of replacement AMP plug connection.

Remove black (sw) wire 4<sup>2</sup> **1** pin 2 and violet/blue (vi/bl) wire **3** pin 6 from connector T6y **2**.

- 1** Black (sw) wire from J59
- 3** Blue/violet (vi/bl) wire from J255
- ① Red (rt) wire from K1/87a
- ② Black (sw) wire K1/30 in connector T6y/2
- ⑤ Red (rt) wire from IPCU/E
- ⑥ Black (sw) wire of IPCU/A in connector T6y/6



**Fan con-  
troller con-  
nection**

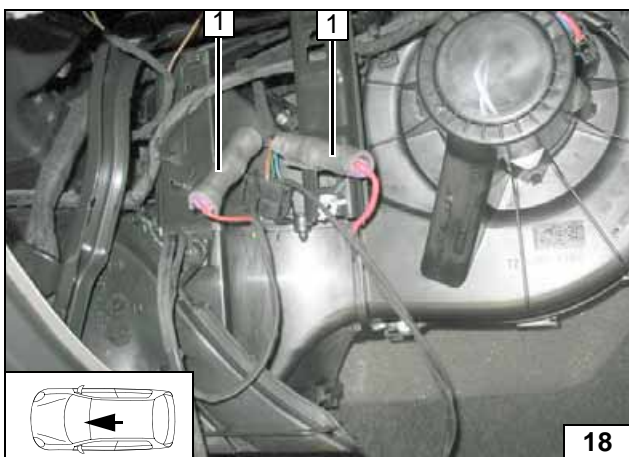

Provide connectors with rattle protection **1** (1x each).



**Fan con-  
troller con-  
nection**

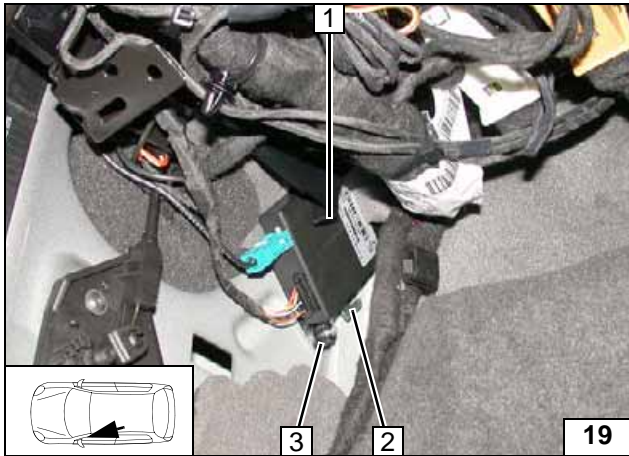

### Remote Option (Telestart)

- 1 Receiver
- 2 Bracket
- 3 Existing stud bolt, plastic nut

Installing receiver

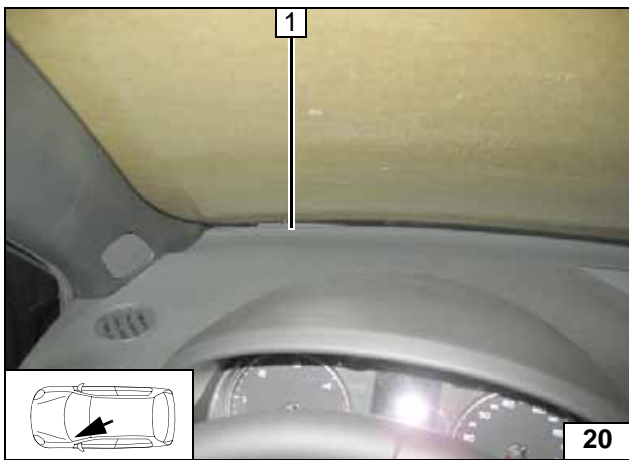

- 1 Antenna

Installing antenna

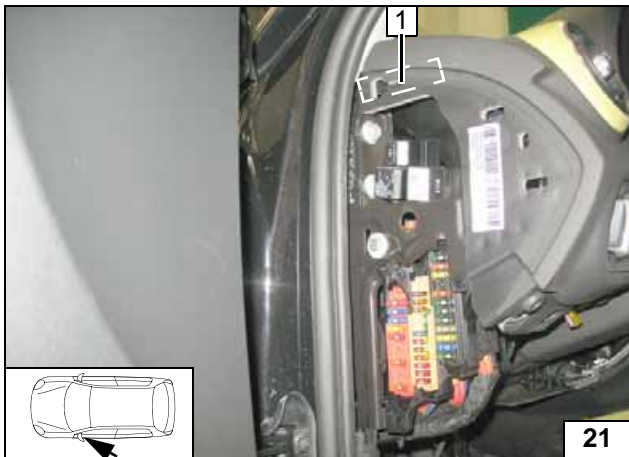

### Temperature sensor T100 HTM

Fasten temperature sensor 1 with double-sided adhesive tape.



Installing temperature sensor

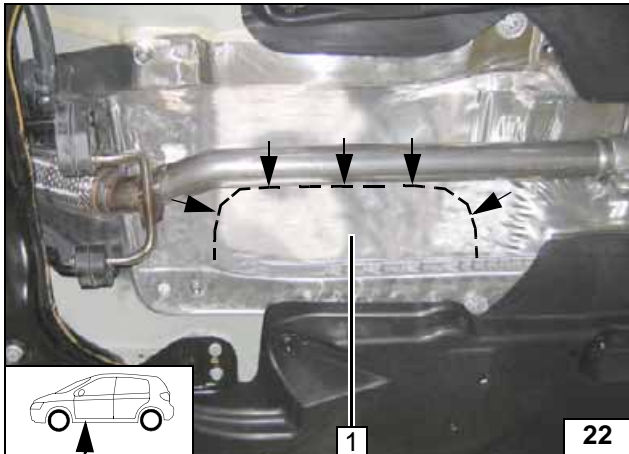

### Preparing Installation Location

Place heat guard plate **1** in the area of the marking on the tunnel.



Applying heat guard plate

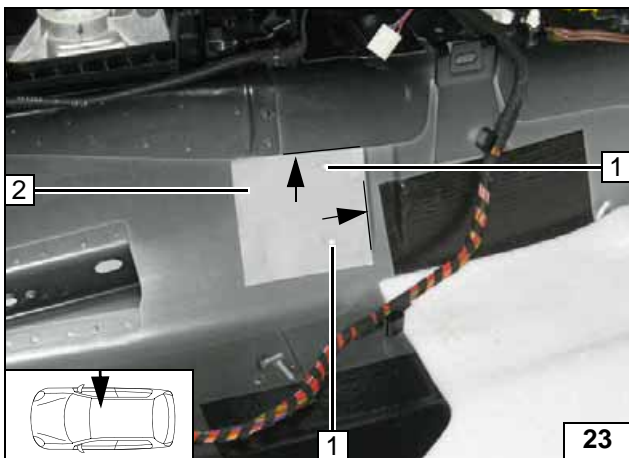

The figure shows the center tunnel on the front passenger side. Cut out template **2** and apply as shown and copy hole pattern **1** [2x] 7 mm dia. !



Copying hole pattern

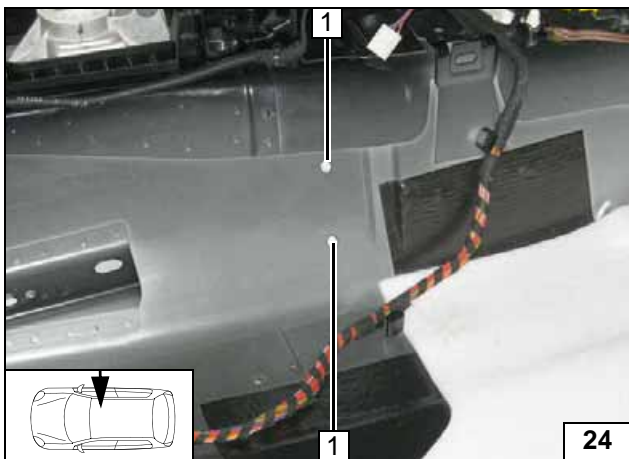

Insert bolt M6x20, large diameter washer **1** [2x each] in hole!



Preparing installation location

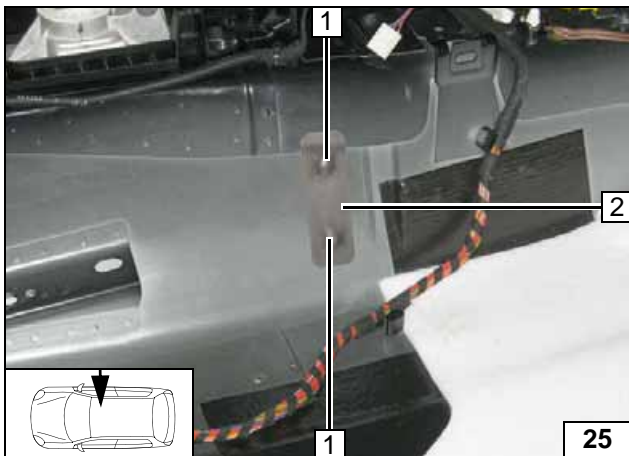

Glue insulation strip **2** on bolt heads **1** [2x]!



Preparing installation location

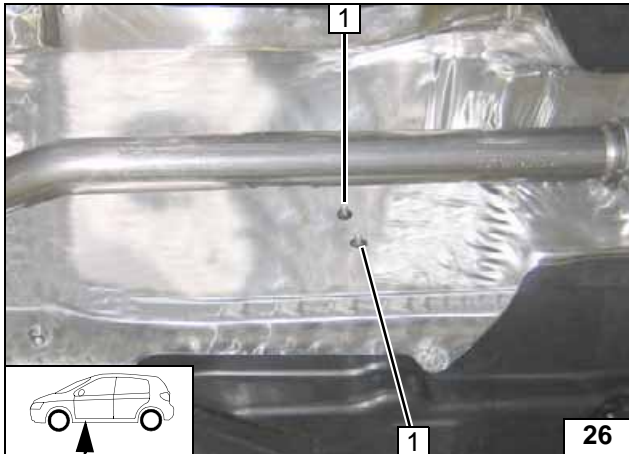

Secure bolts M6x20 with one pin lock each 1.



Mounting pin lock

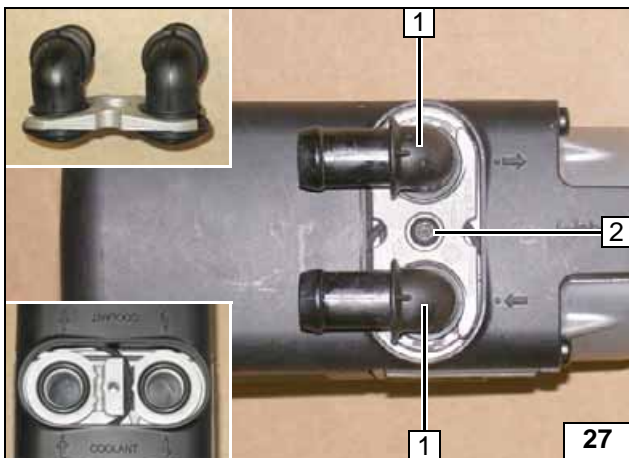

### Preparing Heater

- 1 Water connection piece, sealing ring [2x each]
- 2 Self-tapping bolt 5x15, retaining plate, water connection piece



Assembling water connection piece

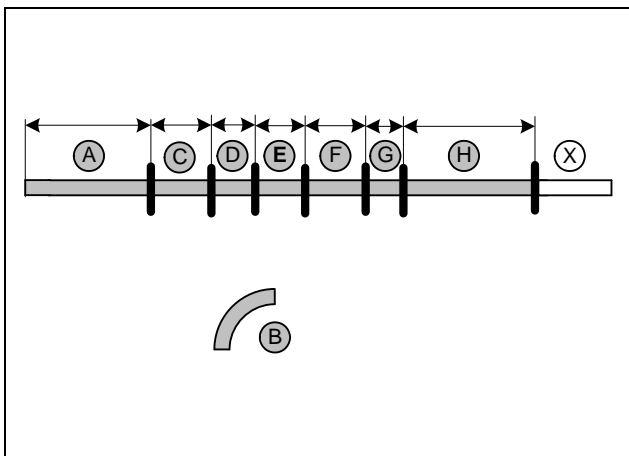

Discard section X.  
Hose B = 90° moulded hose 18 mm dia.

- A = 420
- C = 145
- D = 80
- E = 115
- F = 140
- G = 60
- H = 460

Cutting hoses to length

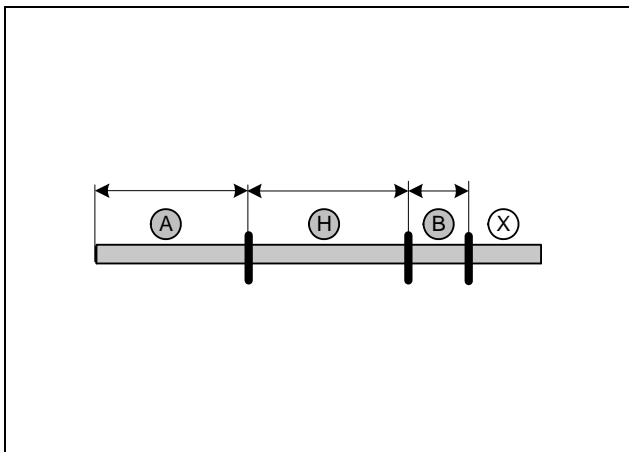

Discard section X.

- A = 350
- B = 50
- H = 400



Cutting heat protection hose to length

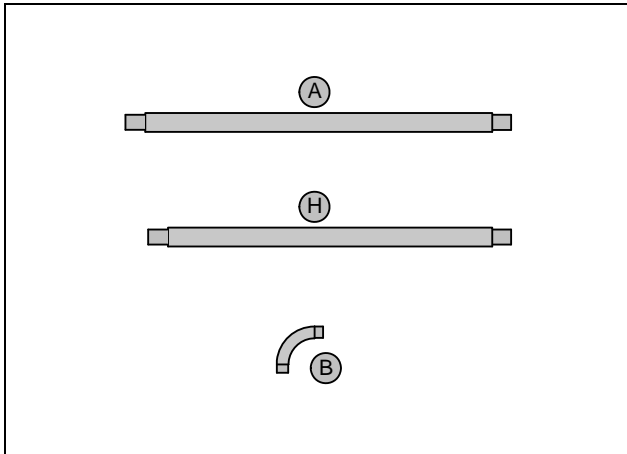

Pulling on heat protection hoses

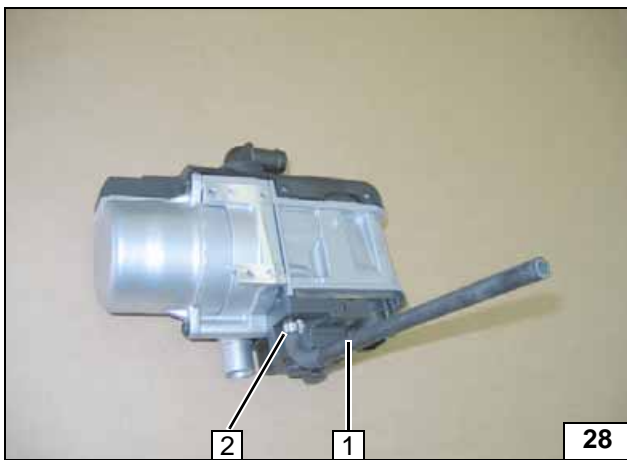

- 1 Moulded hose (fuel)
- 2 10 mm dia. clamp

Premounting heater

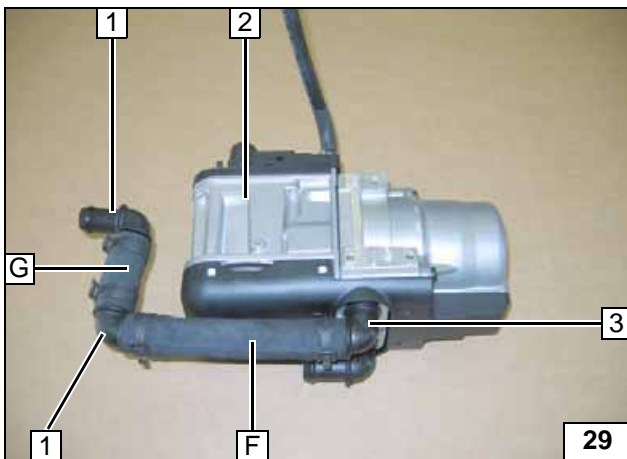

All spring clips = 25 mm dia.

- 1 Connecting pipe 90° 18x18 mm dia. [2x]
- 2 Heater
- 3 Water connection piece, heater outlet



Premounting heater

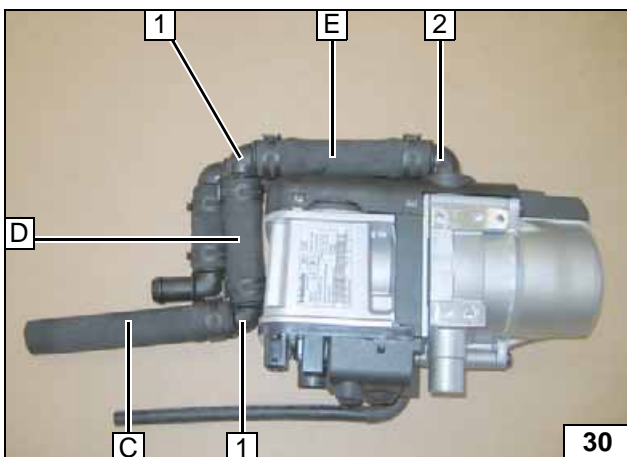

All spring clips = 25 mm dia.

- 1 Connecting pipe 90° 18x18 mm dia. [2x]
- 2 Water connection piece, heater inlet



Premounting heater



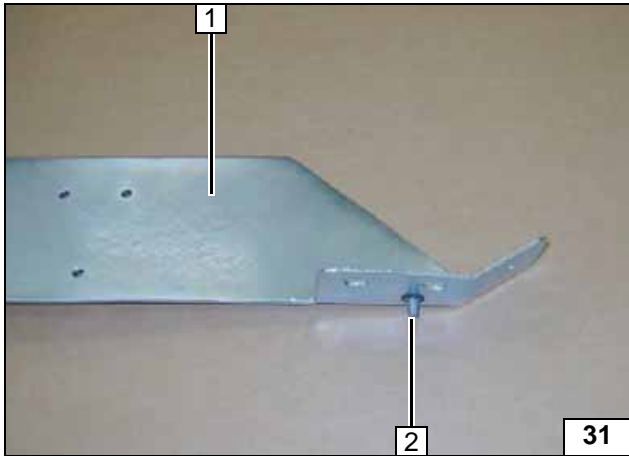

- 1 Bracket
- 2 M6x12 bolt, pin lock

Premounting bracket

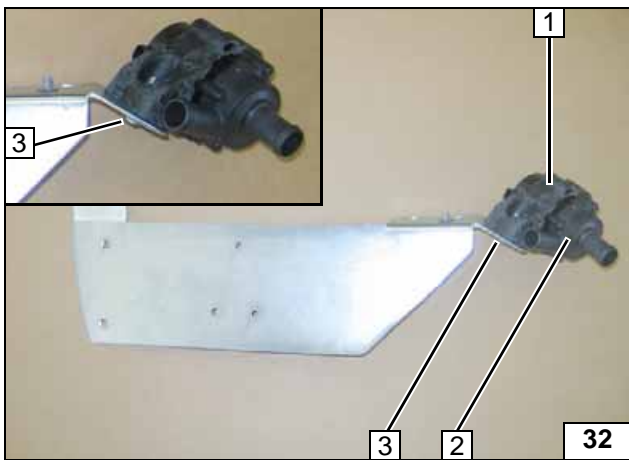

Loosely mount circulating pump 2 on the bracket!

- 1 Mounting for circulating pump
- 3 M6x25 bolt, large diameter washer, flanged nut

Premounting bracket

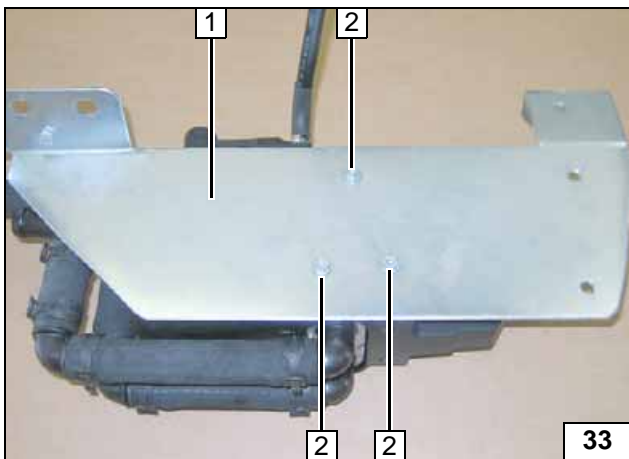

- 1 Bracket
- 2 Self-tapping bolt 5x13 [3x]

Installing bracket

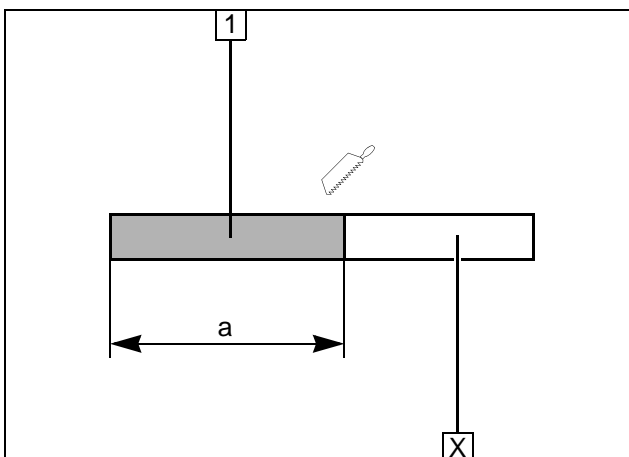

Discard section X.

- 1 Combustion air pipe  
a = 340

Cutting combustion air pipe to length

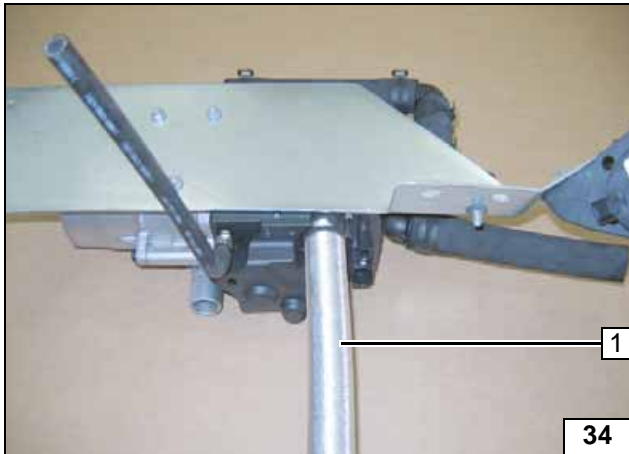

1 Combustion air pipe



Installing combustion air pipe

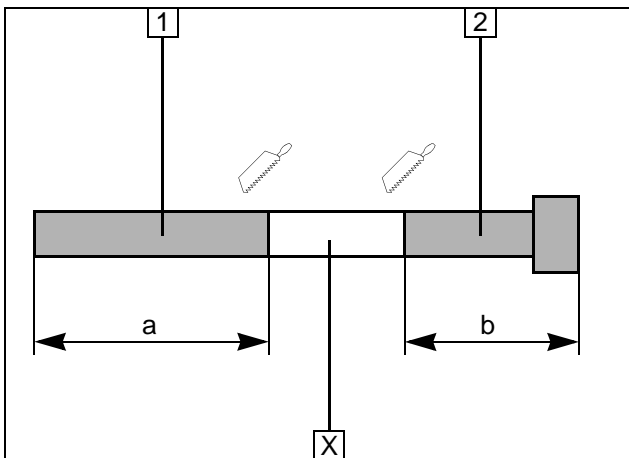

Discard section X.

- 1 Exhaust pipe  
a = 100
- 2 Exhaust end section  
b = 50



Preparing exhaust pipe

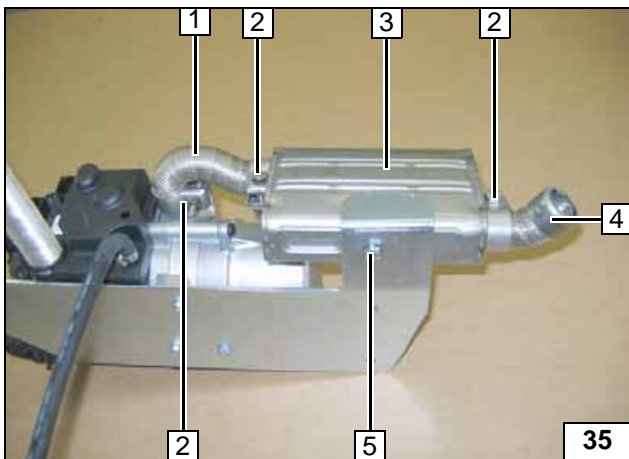

- 1 Exhaust pipe
- 2 Hose clamp [3x]
- 3 Exhaust silencer
- 4 Exhaust end section
- 5 M6x16 bolt, spring lockwasher

Premounting exhaust system

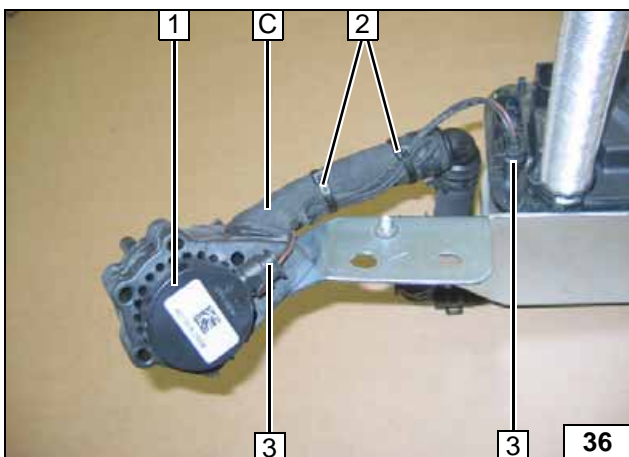

Mount hose C with 25 mm dia. spring clip on circulating pump 1.

Tighten all loose screw connections!

- 1 Cable tie [2x]
- 2 Wiring harness, circulating pump



Premounting heater

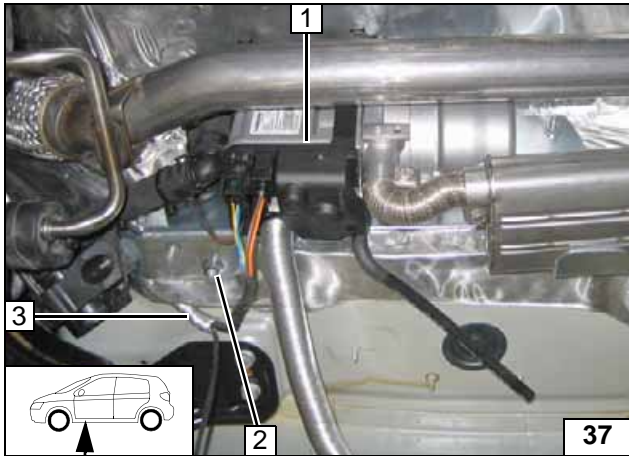
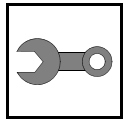

### Installing Heater

Install wiring harness **3** behind heat guard plate and place on heater!

- 1 Heater
- 2 Original vehicle flanged nut M8

Installing heater

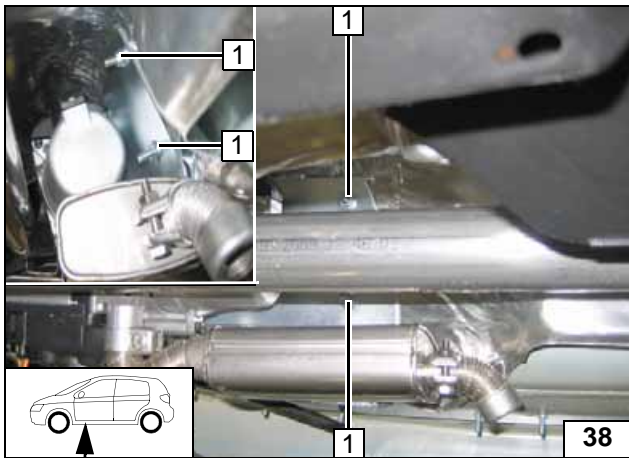

- 1 Flanged nut [2x], bolt M6x20 bolt (pre-assembled)

Installing heater



## Fuel

### CAUTION!

Open the vehicle's fuel tank cap, ventilate the tank and then re-close the tank lock.

Catch any fuel running off with an appropriate container.

Install fuel line and metering pump wiring harness so that they are protected against stone impact. Unless specified otherwise, always fasten using cable ties.

Mount the fuel line and wiring harness with rub protection on sharp edges.

### WARNING!

The fuel line and wiring harness are routed to the metering pump as shown in the wiring harness routing diagram.

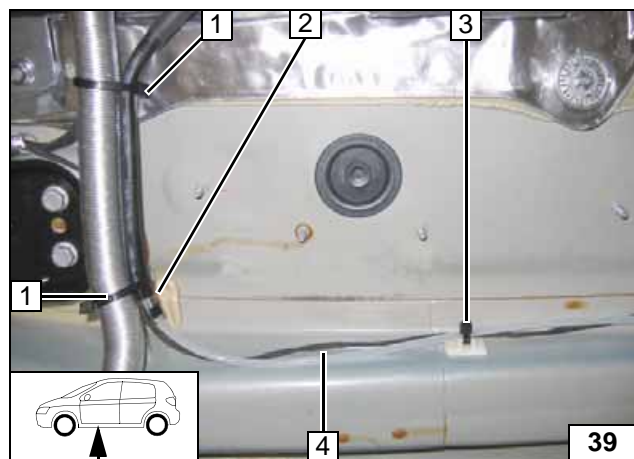

Degrease adhesive point!

- 1 Cable tie [2x]
- 2 Moulded hose (pre-assembled), 10 mm dia. clamp, fuel line
- 3 Adhesive base, cable tie
- 4 Fuel line, wiring harness of metering pump

**Heater connection and routing**

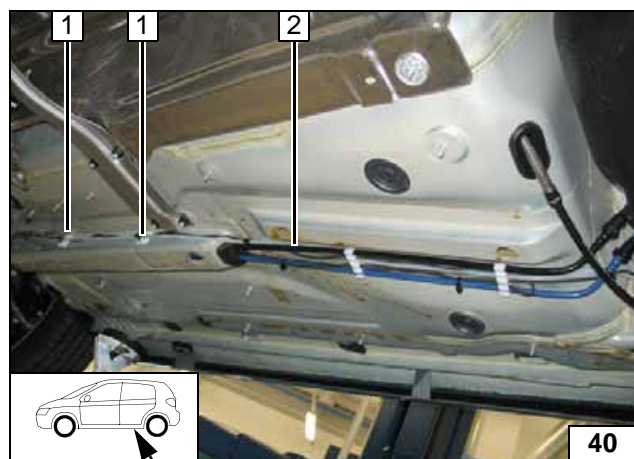

Install fuel line and wiring harness of metering pump 2 along original vehicle fuel lines and secure with cable ties. Degrease adhesive point

- 1 Adhesive base, cable tie [2x each]

**Connecting heater**

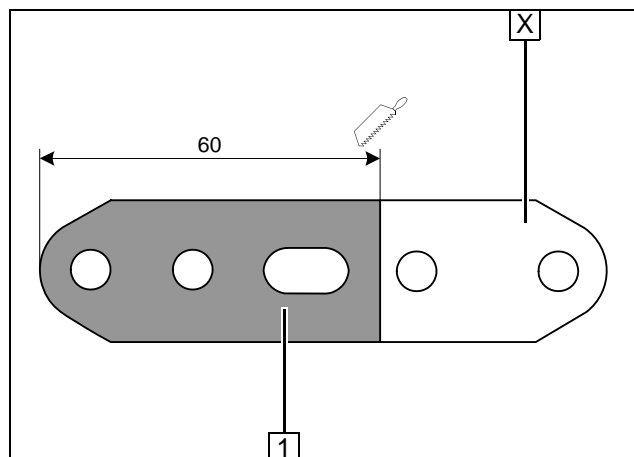

Discard section X.

- 1 Perforated bracket



**Preparing perforated bracket**

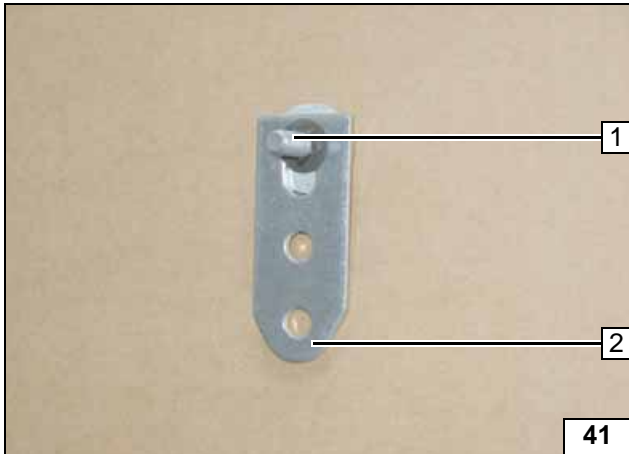

- 1 M6x25 bolt, large diameter washer, pin lock
- 2 Perforated bracket

**Preparing perforated bracket**

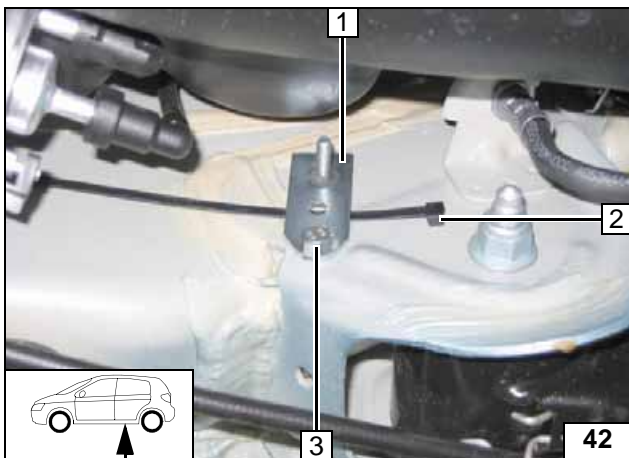

- 1 Perforated bracket
- 2 Cable tie
- 3 M6x20 bolt, large diameter washer, flanged nut

**Installing perforated bracket**

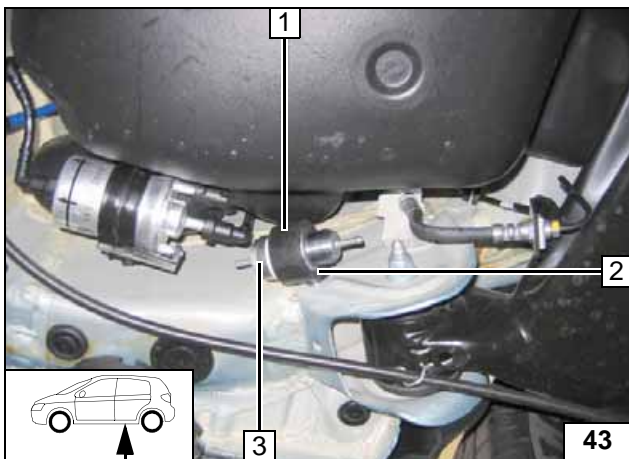

- 1 Mounting for metering pump, flanged nut
- 2 Cable tie pulled through mounting for metering pump.
- 3 Metering pump



**Mounting the metering pump**

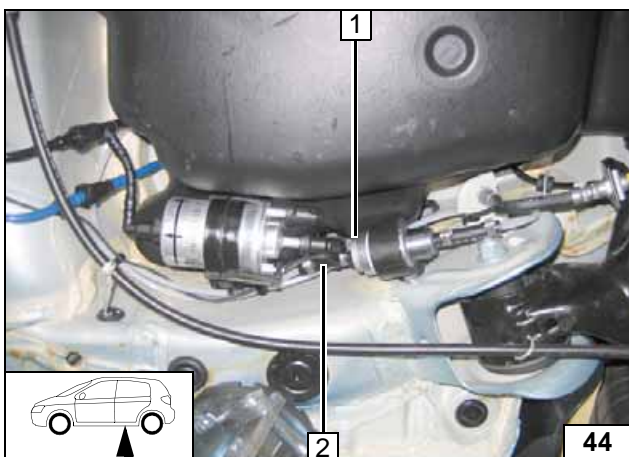

- 1 Metering pump, metering pump wiring harness
- 2 Fuel line, hose section, 10 mm dia. clamp [2x]



**Connecting metering pump**

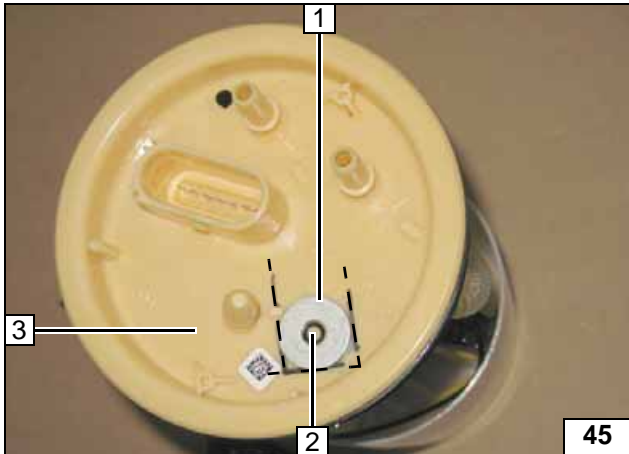

Remove fuel-tank sending unit **3** according to manufacturer's instructions. Position washer **1** according to existing embossing!

**2** Transfer hole pattern, 6 mm dia. hole



**Fuel extraction**

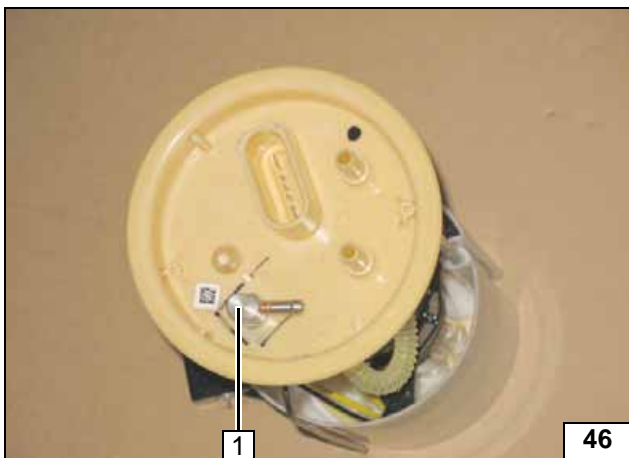

Shape fuel standpipe **1** according to template, cut to length and insert!



**Installing fuel standpipe**

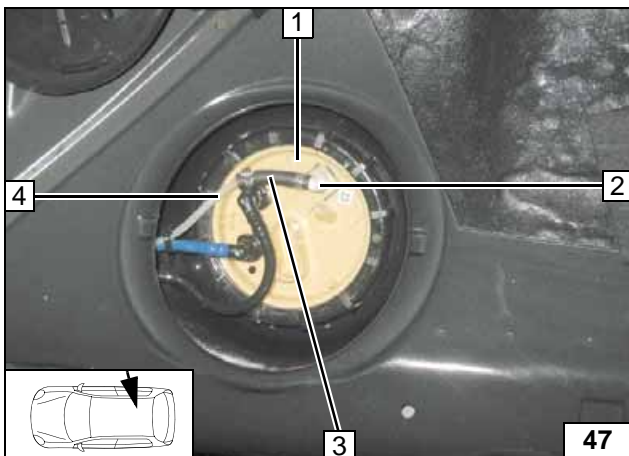

Install fuel-tank sending unit **1** in accordance with manufacturer's instructions.

- 2** Fuel standpipe
- 3** Hose section, 10 mm dia. clamp [2x]
- 4** Fuel line



**Connecting fuel line**

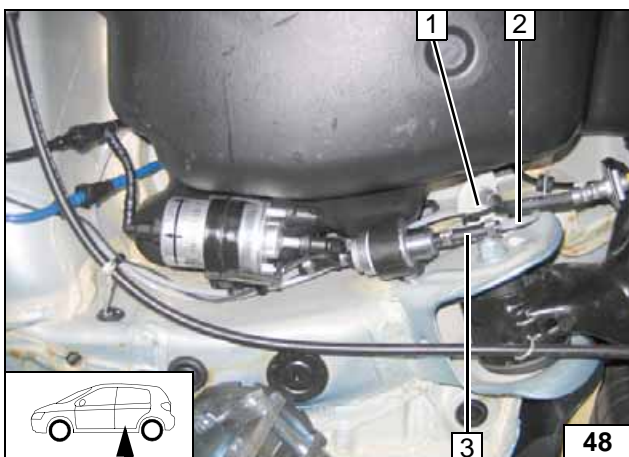

- 1** Cable tie
- 2** Fuel line
- 3** Hose section, 10 mm dia. clamp [2x]



**Connecting metering pump**

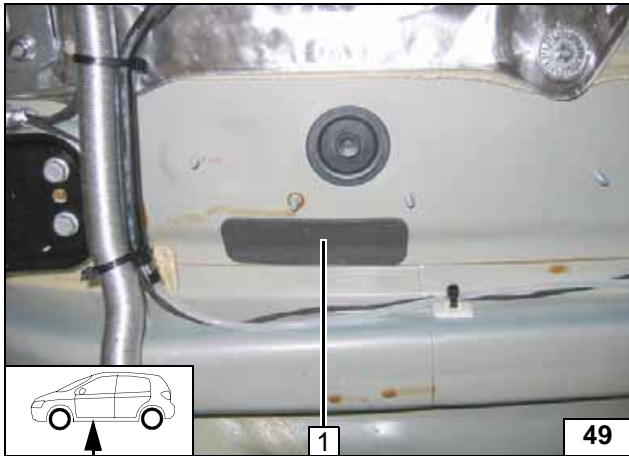
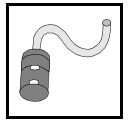

### Combustion Air

Glue insulation strip 1 as shown.



Premounting bracket

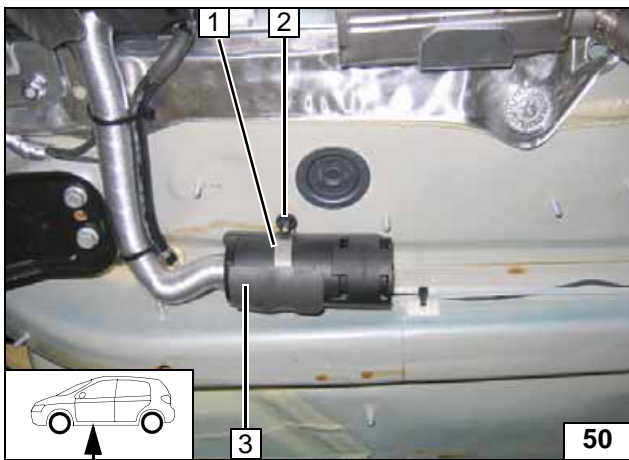

Divide insulation strip 3 in the centre and glue as shown.

- 1 51 mm dia. pipe clamp
- 2 Plastic nut on original vehicle stud bolt



Premounting heater



## Coolant Circuit





### WARNING!

Any coolant running off should be collected using an appropriate container. Install hoses so that they are kink-free. Unless specified otherwise, always fasten using cable ties. Position clamps so that other hoses cannot be damaged. The heater must be filled with coolant when installing the hoses. The connection should be "inline" based on the following diagram:

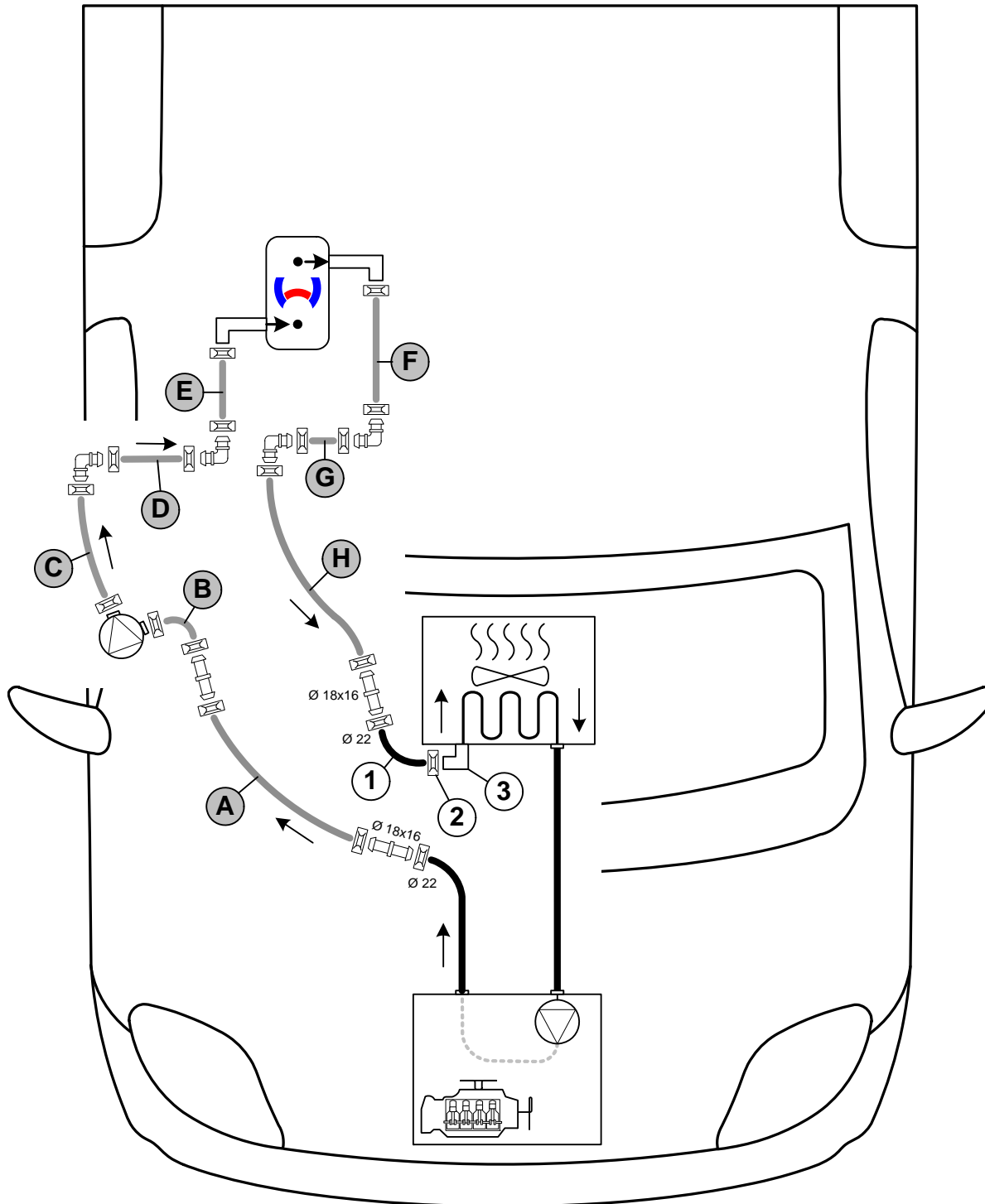

Hose installation diagram



All spring clips without a specific designation  = 25 mm dia. **1** = Original vehicle spring clip.  
**2** = Original vehicle spring clip  . **3** = Original vehicle quick-release coupling.  
 All connecting pipes without a specific designation  and  = 18x18 mm dia.





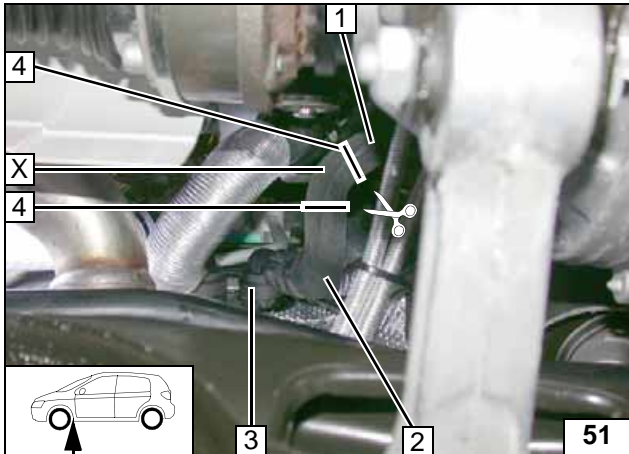

Release original vehicle quick-release coupling **3** at the connection piece. Remove hose section at heat exchanger inlet **2**. Remove hose insulation in the area of the cutting points.

Discard section **X**.

- 1** Engine outlet hose section
- 4** Cutting point [2x]



**Cutting point**

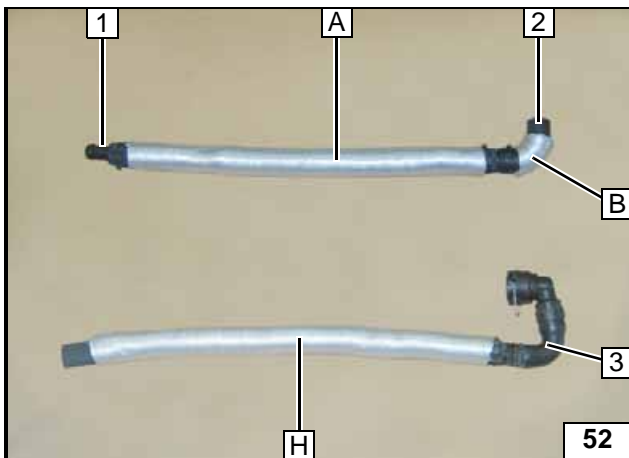

Mount original vehicle hose section **3** to hose **H** as shown. Align quick-release coupling as shown.

- 1** Connection of engine outlet
- 2** Connection of circulating pump



**Preparing hoses**

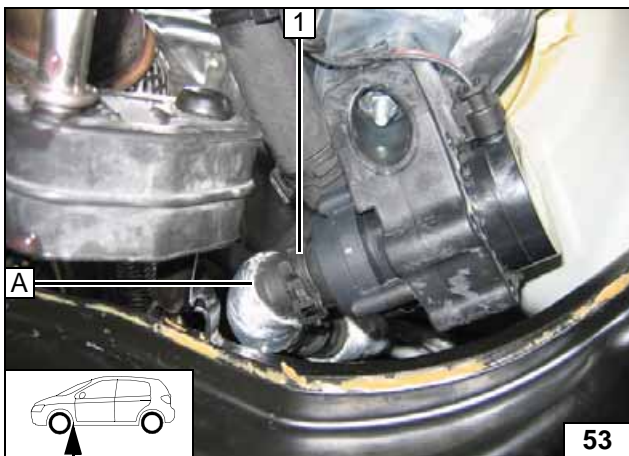

- 1** Circulating pump

**Connect-  
ing heater**

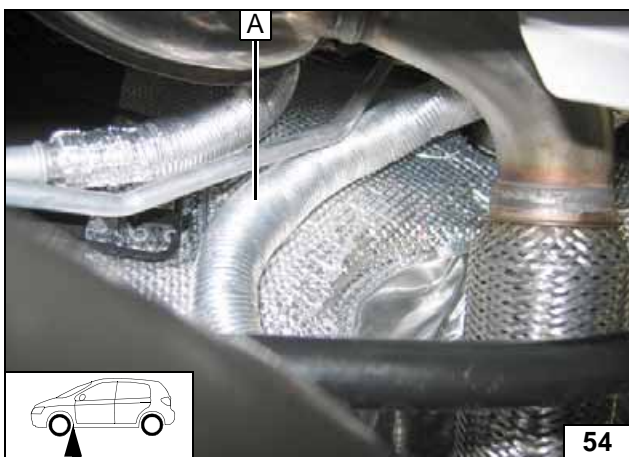

**Routing in  
engine  
compartment**

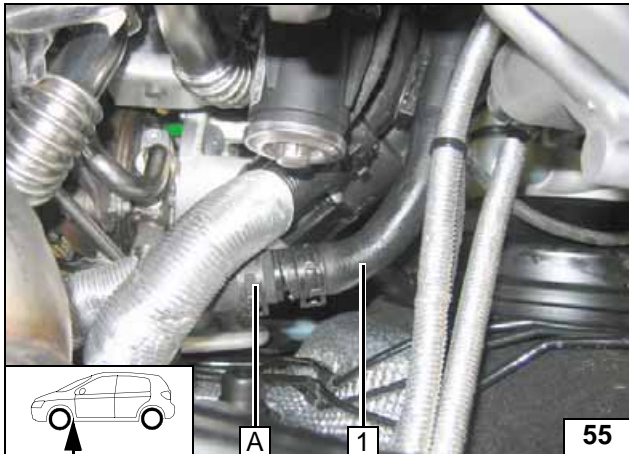

1 Engine outlet hose section

Connect-  
ing engine  
outlet

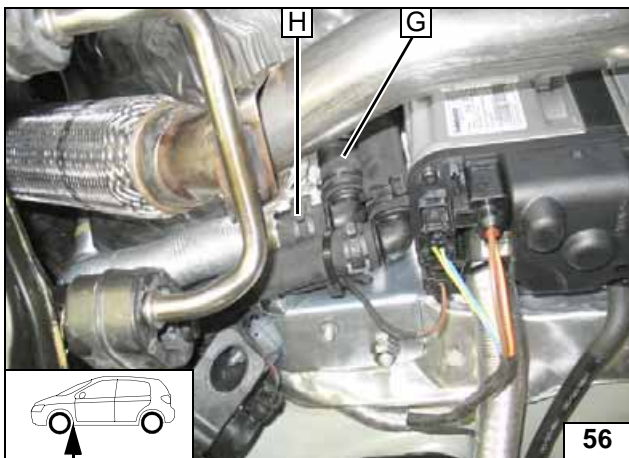

Connect-  
ing heater

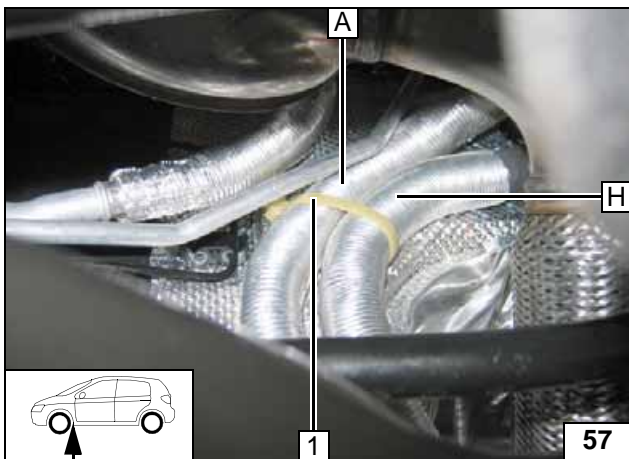

Ensure sufficient distance to neighbouring components.



1 Cable tie (temperature resistant)

Routing in  
engine  
compartment

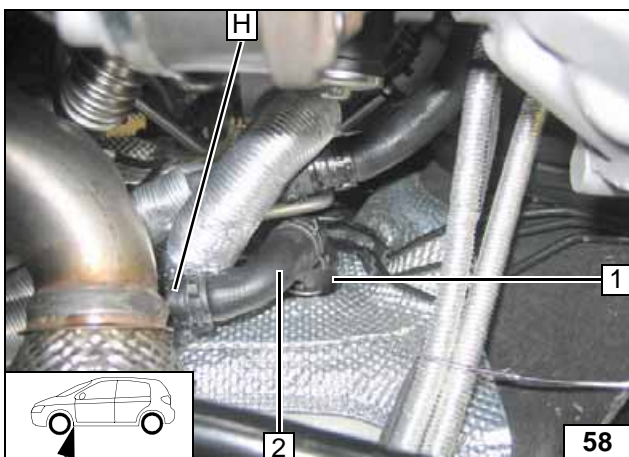

Align hoses. Ensure sufficient distance to neighbouring components, adjust, if necessary.



1 Original vehicle quick-release coupling at the heat exchanger inlet  
2 Original vehicle hose section

Connec-  
tion of heat  
exchanger  
inlet

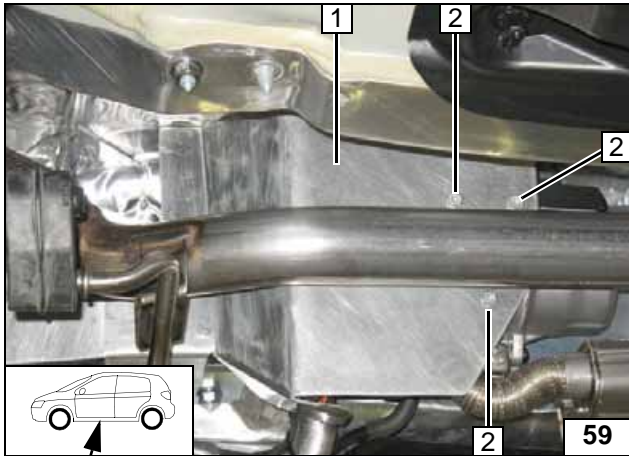

**Guard Plate**

- 1 Guard plate
- 2 Self-tapping bolt 5x13 [3x]

Mounting guard plate

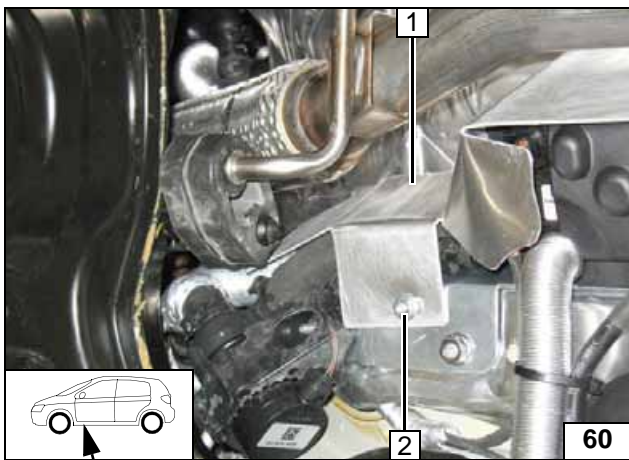

- 1 Guard plate
- 2 Flanged nut on M6x12 bolt

Mounting guard plate

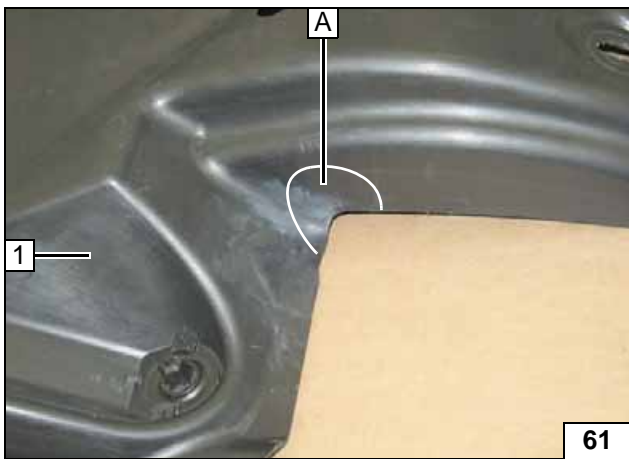

**Underbody Trim**

Cut out underbody trim 2.

A section



Cutting out underbody trim

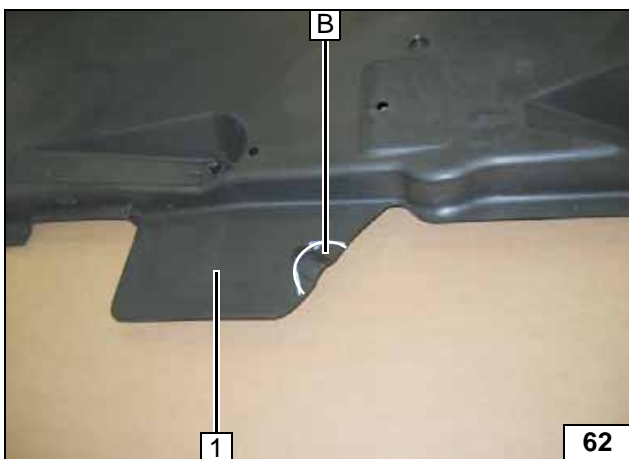

Cut out underbody trim 2.

B section



Cutting out underbody trim



## Final Work

### WARNING!

Reassemble the disassembled components in reverse order. Check all hoses, clamps and all electrical connections for firm seating. Insulate and tie back all loose lines.

Only use manufacturer-approved coolant. Spray the heater components with anti-corrosion wax (Tectyl 100K, Order No. 111329).



- **Connect the battery.**
- **Fill and bleed the coolant circuit according to the vehicle manufacturer's specifications.**
- **Set digital timer, teach telestart transmitter.**
- **Make settings on A/C control panel according to the "Operating Instructions for End Customer".**
- **Place the "Switch off parking heater before refueling" signboard in the area of the filler neck.**
- **For initial start-up and function check, see installation instructions.**



Mount underbody cover **1**.  
Ensure sufficient distance to neighbouring components.

- A** Cut-out for exhaust outlet
- B** Cut-out for combustion air pipe

**Underbody trim**

Webasto Thermo & Comfort SE  
Postfach 1410  
82199 Gilching  
Germany  
Internet: [www.webasto.com](http://www.webasto.com)  
Technical Extranet:  
<http://dealers.webasto.com>

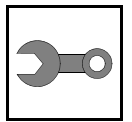

Template for Bracket

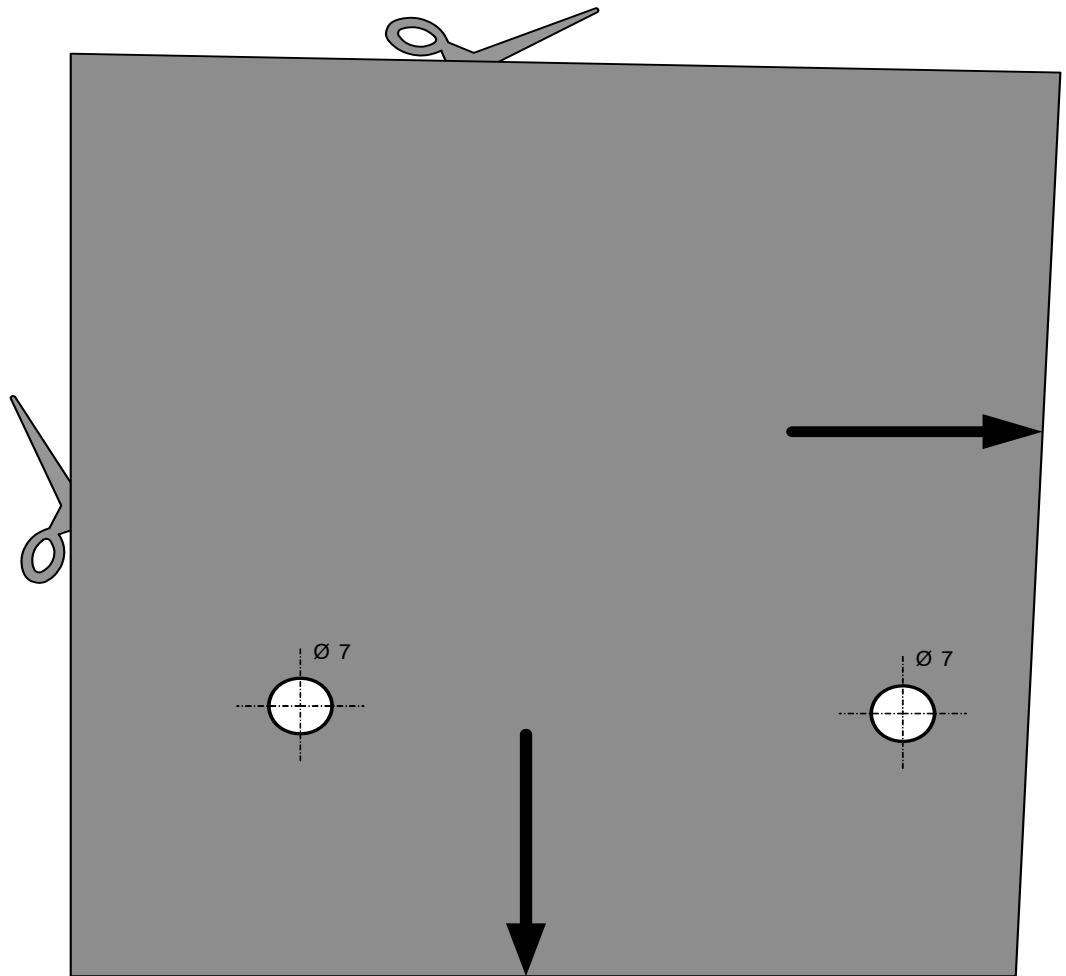

100mm



Scale 1:1

Compare the size of the printed version with dimension lines.  
Permitted tolerance a maximum of 2%.

Set the printer settings to "no margin" or "minimise margins" and 100% of the normal size.

100mm

0



### Template for Fuel Standpipe

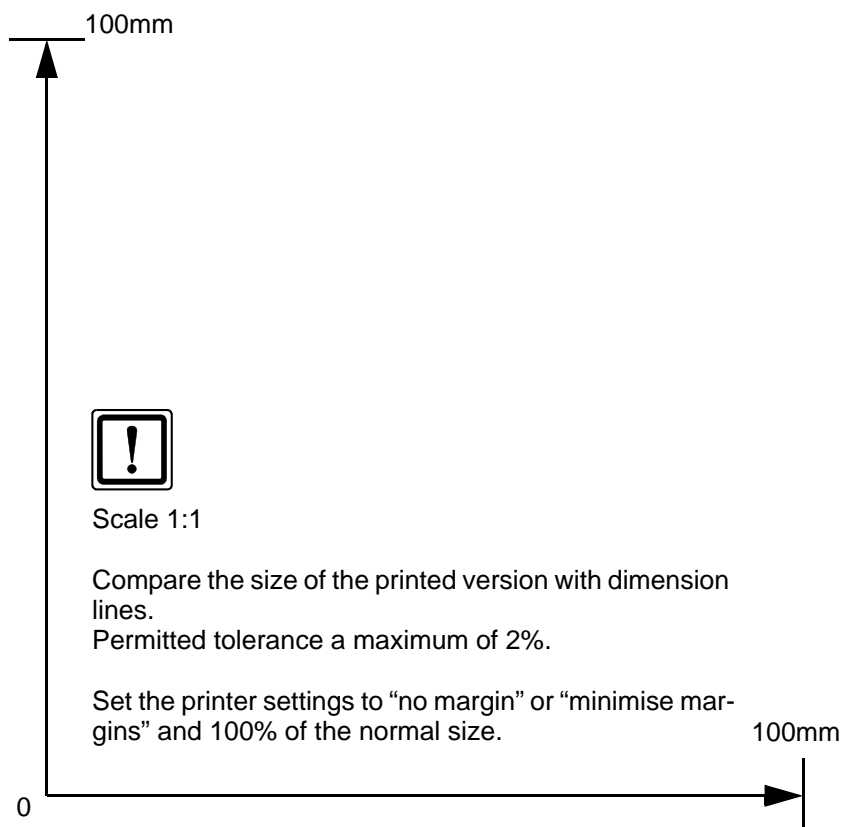
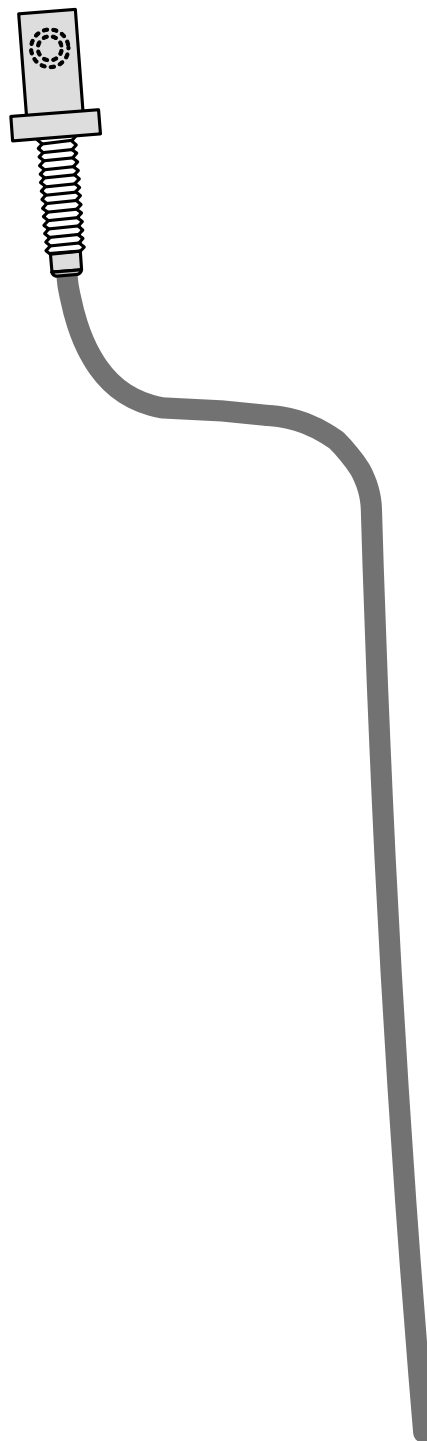

## Operating Instructions for Manual A/C System

Please remove this page in case of manual air-conditioning and add it to the vehicle operating instructions.

**Note:**

We recommend matching the heating time to the driving time.

Heating time = driving time

**Example:**

For a driving time of approx. 20 min. (in one direction), we recommend not exceeding a switch-on time of 20 min.

Passenger compartment monitoring, if installed, must be deactivated in addition to the vehicle settings for the heating operation.

Please refer to the Operating Manual of the vehicle for instructions concerning the deactivation.

Before parking the vehicle, make the following settings:



- 1 Set temperature to "max."
- 2 Set fan to level "1", or max. "2"
- 3 Air outlet to windscreen

**Air-conditioning control panel**

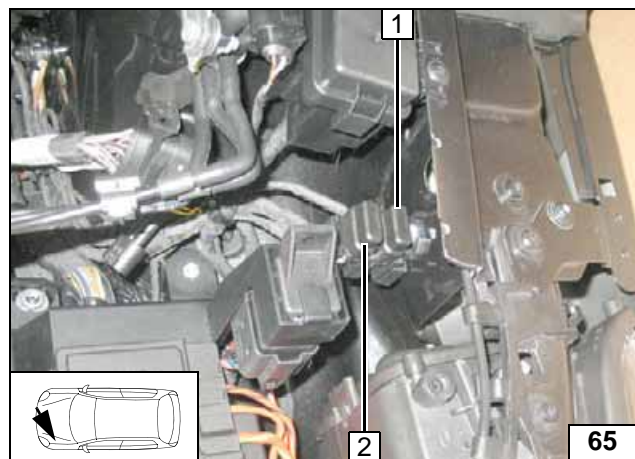

- 1 30A heater fuse F2
- 2 20A passenger compartment main fuse F1

**Engine compartment fuses**

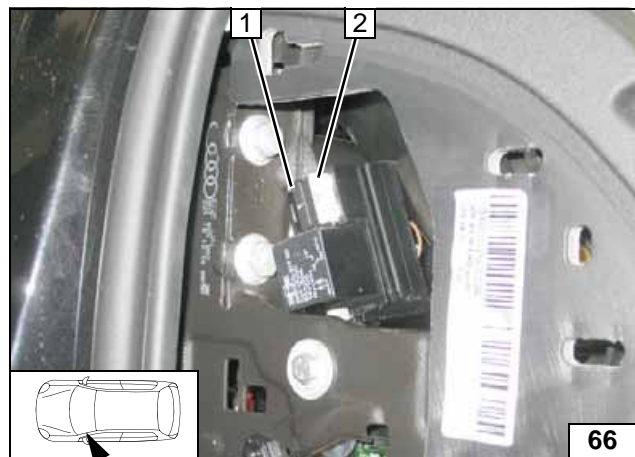

- 1 1A fuse of heater control F3
- 2 25A fan fuse F4

**Passenger compartment fuses**



## Operating Instructions for Automatic A/C

Please remove this page in case of automatic air-conditioning and add it to the vehicle operating instructions.

### Note:

We recommend matching the heating time to the driving time.

Heating time = driving time

### Example:

For a driving time of approx. 20 min. (in one direction), we recommend not exceeding a switch-on time of 20 min.

Passenger compartment monitoring, if installed, must be de-activated in addition to the vehicle settings for the heating cycle.

Please refer to the Operating Manual of the vehicle for instructions concerning the deactivation.

Before parking the vehicle, make the following settings:



The fan speed does not have to be set!

- 1 Set temperature to "HI"
- 2 Air outlet to windscreen

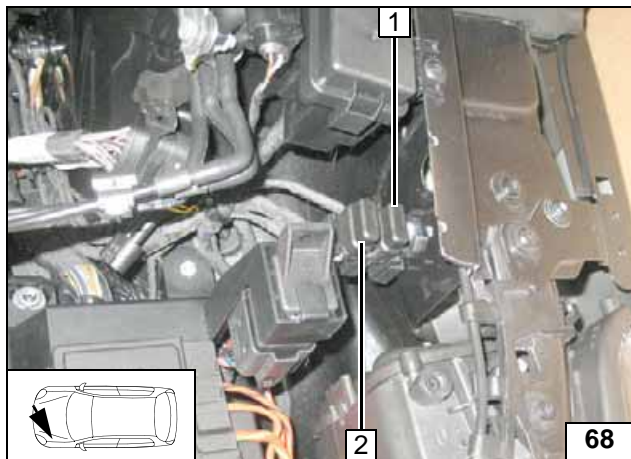

- 1 30A heater fuse F2
- 2 20A passenger compartment main fuse F1

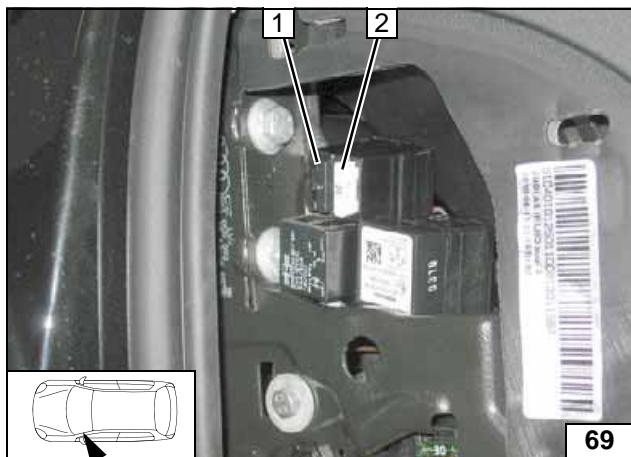

- 1 1A fuse of heater control F3
- 2 25A fan fuse F4



**Air-conditioning control panel**

**Engine compartment fuses**

**Passenger compartment fuses**