

Water Heater



Thermo Top Evo Parking Heater



Installation documentation

Audi A1

Petrol

from Model Year 2010

Left-hand drive vehicle

Manual transmission

S tronic

Passenger compartment monitoring not checked!



WARNING!

Hazard warning:

Incorrect installation or repair of Webasto heating systems may cause a fire or result in the emission of carbon monoxide, which can be fatal. Serious or fatal injuries can be caused as a result.



Specialist company training, technical documentation, specialised tools and equipment are required to install and repair Webasto heating and cooling systems. Only original Webasto parts must be used. For this, also see the catalog of air and water heater accessories from Webasto.

NEVER attempt to install or repair Webasto heating or cooling systems if you have not successfully completed the company training and thereby acquired the required technical skills, or if you do not have access to the required technical documentation, tools and equipment needed to carry out correct installation and repairs.

ALWAYS follow all Webasto installation and repair instructions and observe all warnings.

The initial startup is to be executed with the Webasto Thermo Test Diagnosis.

Webasto does not accept any liability for defects and damage that are attributable to installation by untrained staff.

Table of Contents

| | | | |
|---|----|---|----|
| Validity | 2 | Preparing installation location | 14 |
| Heater/Installation Kit | 3 | Preparing heater | 15 |
| Foreword | 3 | Installing heater | 18 |
| General Instructions | 3 | Coolant circuit 1,2 TFSI | 19 |
| Special Tools | 3 | Coolant circuit 1.4 TFSI | 21 |
| Explanatory Notes on Document | 4 | Fuel | 23 |
| Preliminary Work | 5 | Combustion air | 26 |
| Heater installation location | 5 | Exhaust gas | 27 |
| Preparing electrical system | 6 | Final Work | 29 |
| Electrical system | 8 | Template for fuel standpipe | 30 |
| Fan controller manual air conditioning system | 9 | Operating Instructions for End Customer | 31 |
| Automatic air-conditioning fan controller | 11 | | |
| Remote option (Telestart) | 13 | | |

Validity

| Manufacturer | Model | Type | EG-BE No./ABE |
|--------------|-------|------|-----------------------------|
| Audi | A1 | 8X | e1 * 2007 / 46 * 0414 * ... |

| Engine type | Engine model | Output in kW | Displacement in cm ³ |
|-------------|---------------|--------------|---------------------------------|
| CBZA | Petrol / TFSI | 63 | 1197 |
| CAXA | Petrol / TFSI | 90 | 1390 |

Vehicle and engine types, equipment variants and national specifications not listed in this installation documentation have not been tested. However, installation according to this installation documentation may be possible.

The installation location of the digital timer should be confirmed with the end customer before installation.

Heater/Installation Kit

| Quantity | Description | Order No.: |
|----------|--|----------------|
| 1 | Standard accessories <i>Thermo Top Evo</i> | See price list |
| 1 | Installation kit for Audi A1 TFSI 2010 | 1316710A |
| 1 | Heater control | See price list |

Also required for automatic air-conditioning

| Quantity | Description | Order No.: |
|----------|--------------------------------|------------|
| 1 | Automatic air-conditioning kit | 1316697B |

Foreword

This installation documentation applies to vehicles Audi A1 Petrol - for validity, see page 2 - from model year 2010 and later, assuming technical modifications to the vehicle do not affect installation, any liability claims excluded. Depending on the vehicle version and equipment, modifications may be necessary during installation with respect to this installation documentation.

However, the stipulations in the "installation documentation", the "operating instructions" and "installation instructions" for the *Thermo Top Evo* must always be observed.

The corresponding rules of technology and any information from the vehicle manufacturer should be observed during the installation work.

General Instructions

Installation should be carried out according to the general, standard rules of technology. Unless specified otherwise, fasten hoses, lines and wiring harnesses to original vehicle lines and wiring harnesses using cable ties. Insulate loose wires and tie back!

Sharp edges should be fitted with edge protectors (split-open plastic hose).

Spray unfinished body areas, e.g. drilled holes, with anti-corrosion wax (Tectyl 100K, Order No. 111329). When installing an IPCU, the appropriate settings must be checked and set prior to the installation!

Special Tools

- Torque wrench for 2.0 - 10 Nm
- Hose clamping pliers
- Metric thread-setter kit

Explanatory Notes on Document

To provide you with a quick overview of the individual working steps, you will find an identification mark on the outside top right corner of the page in question.

Mechanical system

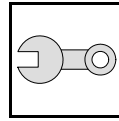

Electrical system

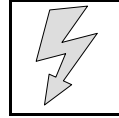

Coolant circuit

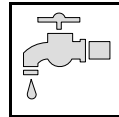

Fuel

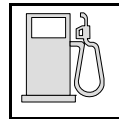

Exhaust gas

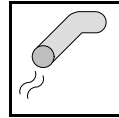

Combustion air

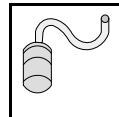

Software

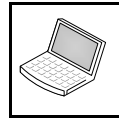

Special features are highlighted using the following symbols:



Specific risk of injury or fatal accidents.



Specific risk of damage to components.



Specific risk of fire or explosion.



Reference to general installation instructions of Webasto components or to the manufacturer's vehicle-specific documents.



Reference to a special technical feature.



The arrow in the vehicle icon indicates the position on the vehicle and the viewing angle.

All dimensions are in mm!

Tightening torque of 5x13 heater bolts = 8Nm!

Tightening torque of 5x15 bolt of water connection piece retaining plate = 7Nm!

Preliminary Work

WARNING!

- Open the fuel tank cap, ventilate the tank.
- Close the tank cap again.
- Disconnect the battery "earth" or "ground" connection. (1.4 TFSI in the luggage compartment)
- Depressurize the cooling system.
- Copy the factory number from the original type label to the duplicate type label.
- Remove years that do not apply from the duplicate label.
- Attach the duplicate label (type label) in the appropriate place.
- Vacuum off engine coolant according to the manufacturer's instructions
- Remove the air filter together with the intake hose.
- Remove battery (only 1.2 TFSI)
- Remove the engine control unit from the bracket
- Dismantle windscreen wipers
- Remove coolant reservoir cap
- Remove engine control unit bracket
- Remove the sound insulation from the coolant reservoir partition wall
- Remove the coolant reservoir partition wall
- Remove windscreen wiper motor
- Remove air intake bridge completely according to manufacturer's specifications (only 1.4 TFSI)
- Remove underride protection
- Remove right vehicle underbody cladding
- Turn up seat area of rear seat bench
- Open the tank-fitting service lid
- Remove left and right cover of the instrument panel
- Remove the glove compartment
- Remove the lower instrument panel trim on the driver's side.

Remove page 31 "Operating Instructions for End Customer" and add to the vehicle operating instructions.

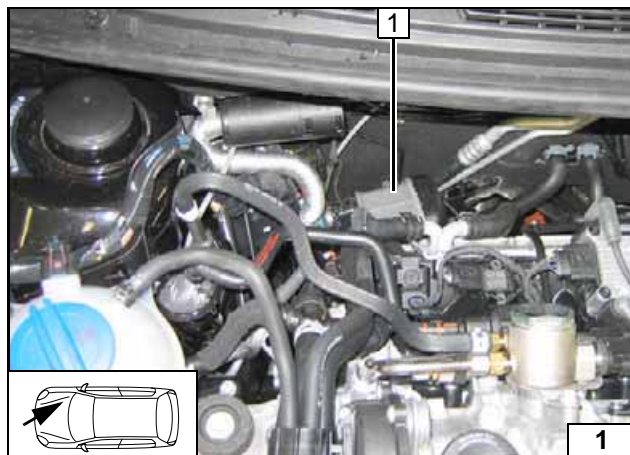

Heater installation location

Figure shows 1,2 TFSI

1 Heater



Installation location

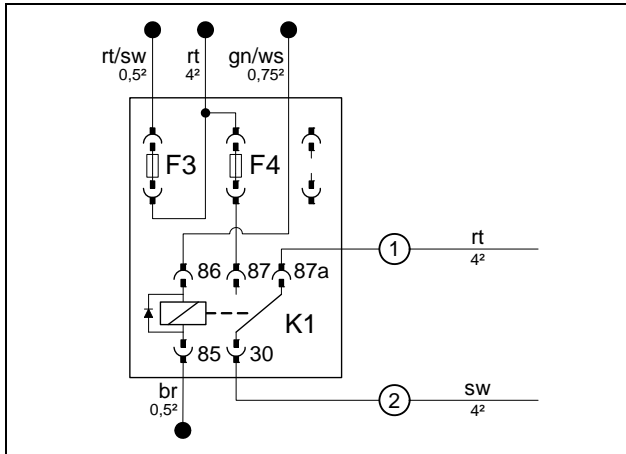

Preparing electrical system

Manual air conditioning system

F4 25A and K1-relay inserted. Insert red (rt) line ① in relay socket K1/87a and black (sw) line ② in relay socket K1/30.



Prepare interior fuse carrier

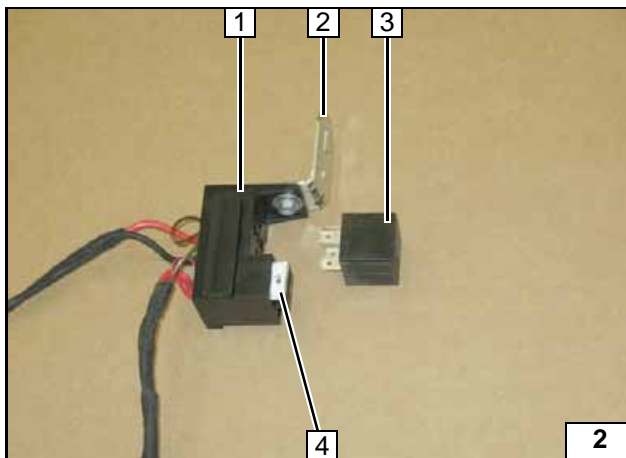

- 1 Interior fuse carrier
- 2 Bracket, bolt M5x16, washer, nut
- 3 Plug relay K1 in relay socket after bracket assembly
- 4 25A fuse F4

Prepare interior fuse carrier

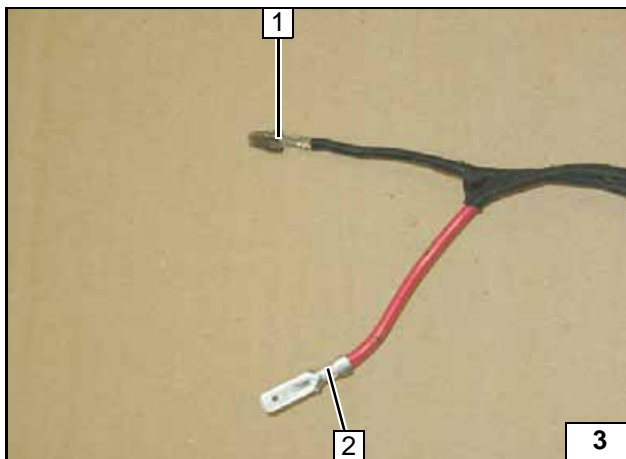

- 1 Standard power timer 4², black (sw) wire ② of K1/30
- 2 Tab connector 4², red (rt) wire ① of K1/87a



Prepare cable connection

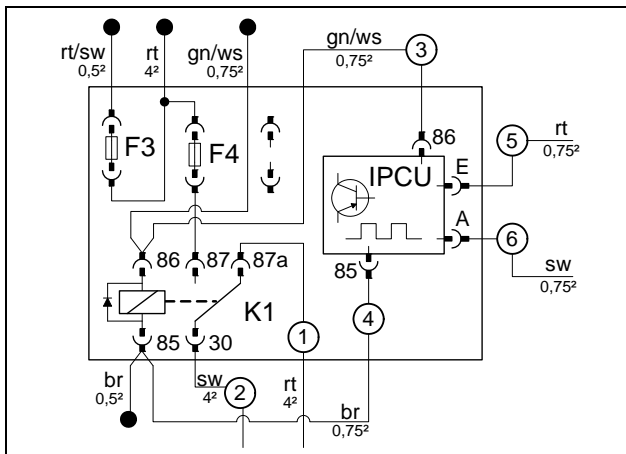

Automatic air-conditioning

F4 25A and K1-relay inserted. Insert red (rt) line ① in relay socket K1/87a and black (sw) line ② in relay socket K1/30. Insert green/white (gn/ws) wire ③ in socket IPCU/86 and connect to K1/86. Brown (br) wire ④ in IPCU/85 socket, red (rt) wire ⑤ in IPCU/E socket and black (sw) wire ⑥ in IPCU/A socket. Pull red (rt) wire ⑤ and black (sw) wire ⑥ in protective sleeving.



Prepare interior fuse carrier

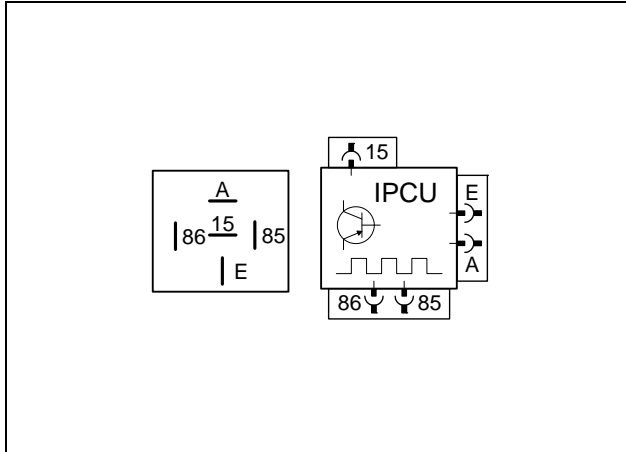

Connect wires to IPCU socket.
View IPCU on contact side!
The IPCU is pre-programmed with the following settings. These setting values must be checked during the function check on the vehicle and adjusted, if necessary.

- Duty cycle: 100%
- Frequency: 1,000 Hz
- Voltage: 3.6V
- Function: High side

Pre-assembling IPCU

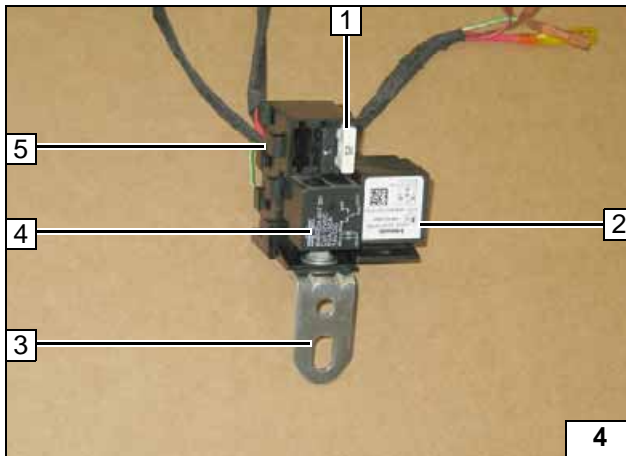

- 1 25A fuse F4
- 2 IPCU
- 3 Bracket, bolt M5x16, washer, nut
- 4 Relay K1
- 5 Fuse/relay carrier interior

Prepare interior fuse carrier

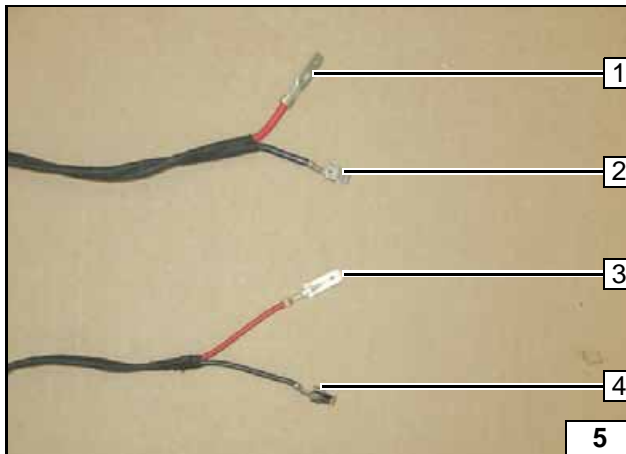

- 1 Tab connector 4², red (rt) wire ① of K1/87a
- 2 Standard power timer 4², black (sw) wire ② of K1/30
- 3 Tab connector 0.5-1², red (rt) wire ⑤ of IPCU/E
- 4 Standard power timer 0.5-1², black (sw) wire ⑥ of IPCU/A

Prepare cable connection

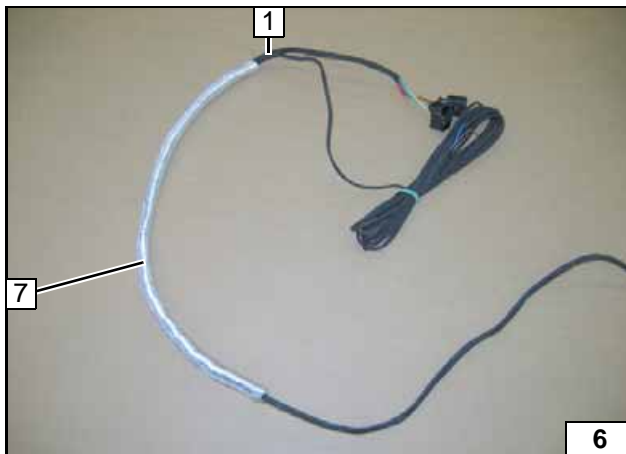

Slit 540 mm long protective pipe 2 longitudinally and pull onto wiring harness of heater 1.



Pull up protective pipe

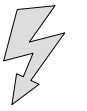

Electrical system

Connection on positive wire

- 1 Positive wire
- 2 Positive distributor

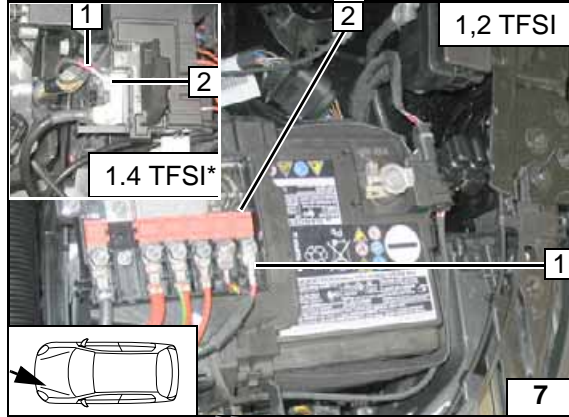

Digital timer

- 1 Digital timer

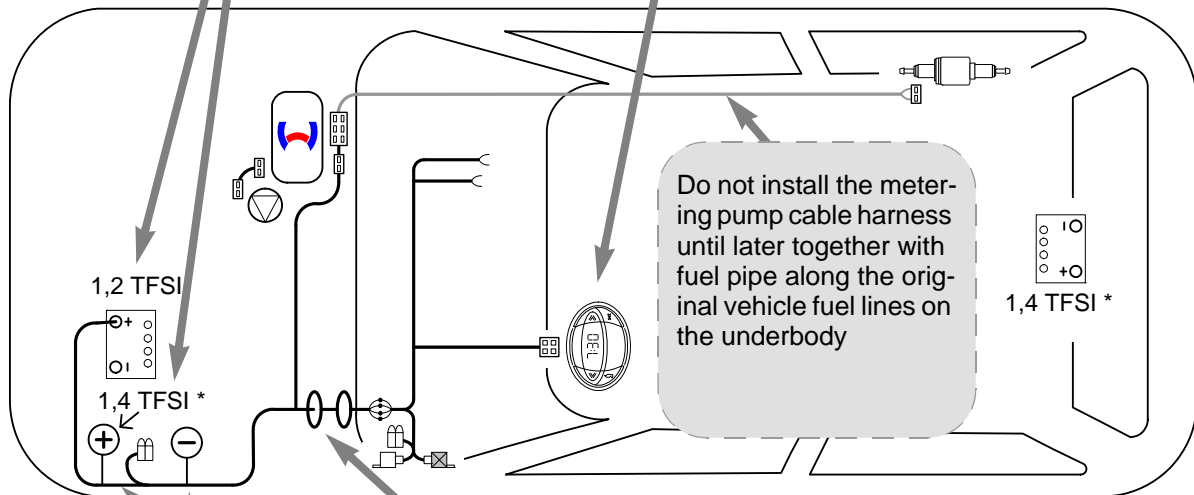
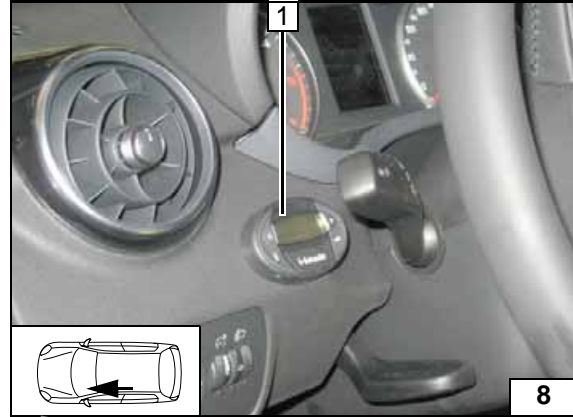

Wiring harness installation diagram

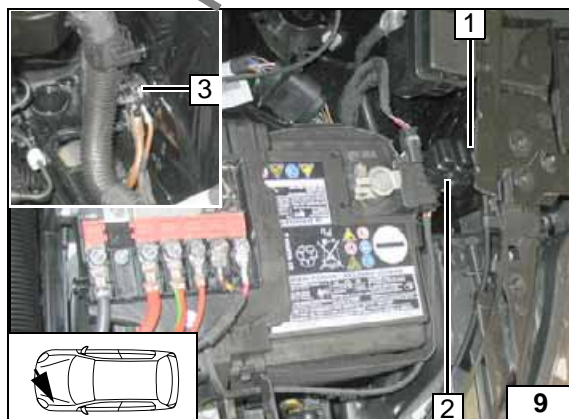

Fuse holder engine compartment

- 1 4.5 mm dia. hole; self-tapping screw 5.5x13; retaining plate, fuse holder (applies for all)
- 2 Fuses F1-2 inserted
- 3 Earth wire on earth point

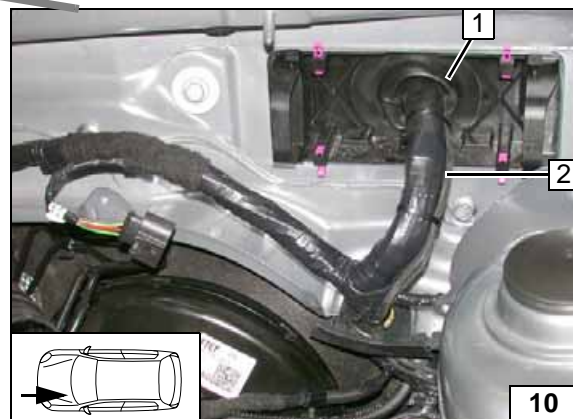

Wiring harness pass through of passenger compartment

- 1 Protective rubber plug pass through, coolant reservoir
- 2 Wiring harness, fuse holder, engine compartment



Fan controller manual air conditioning system

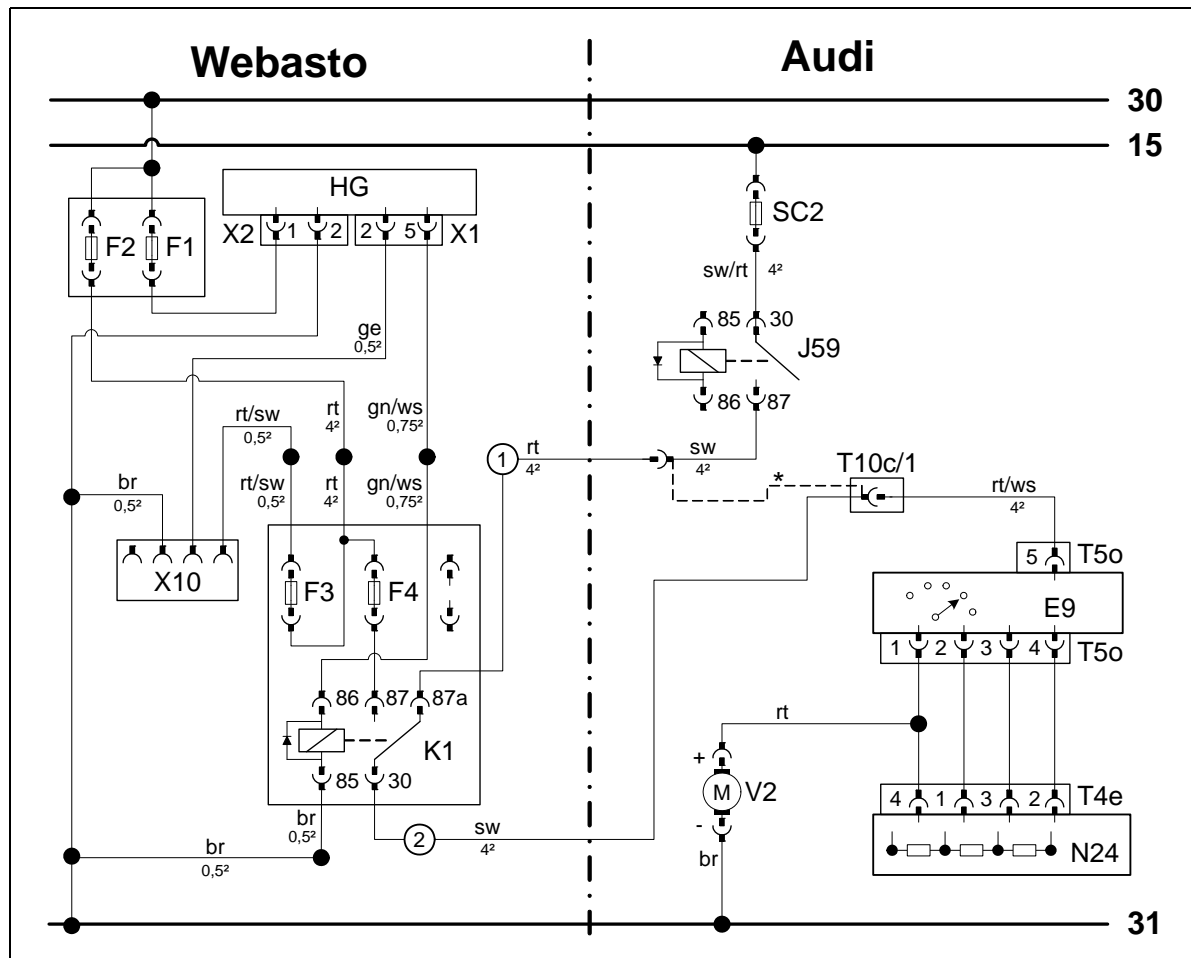

Wiring diagram

| Webasto components | | Vehicle components | | Colours and symbols | |
|--------------------|-----------------------------------|--------------------|------------------|---------------------|--------------------------|
| HG | Heater TT-Evo | V2 | Fan motor | rt | red |
| X1 | 6-pin heater connector | SC2 | Fuse 40A | ws | white |
| X2 | 2-pin heater connector | N24 | Resistor group | sw | black |
| X10 | 4-pin connector Heater control | E9 | Switch unit | br | brown |
| K1 | Fan relay | T ... | Connector | gn | green |
| F1 | Fuse 20A | J59 | Relay X- contact | | |
| F2 | Fuse 30A | | | | |
| F3 | Fuse 1A | | | * | Original condition |
| F4 | Fuse 25A | | | | Wiring colours may vary. |

Legend

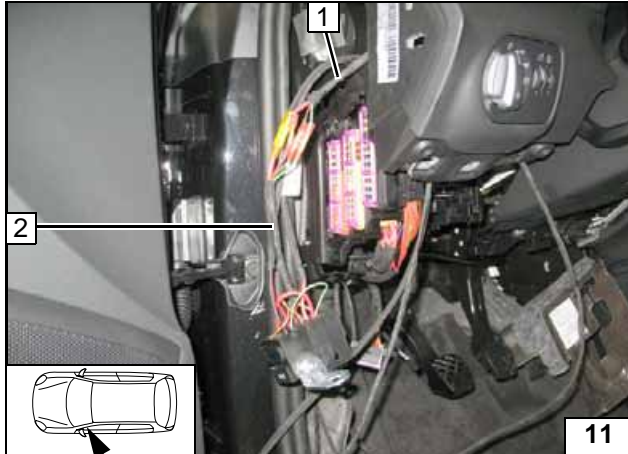

Connect the wiring harnesses of fuse holder in engine compartment **1** and interior **2** colour-matched according to circuit diagram!



Connect wiring harnesses

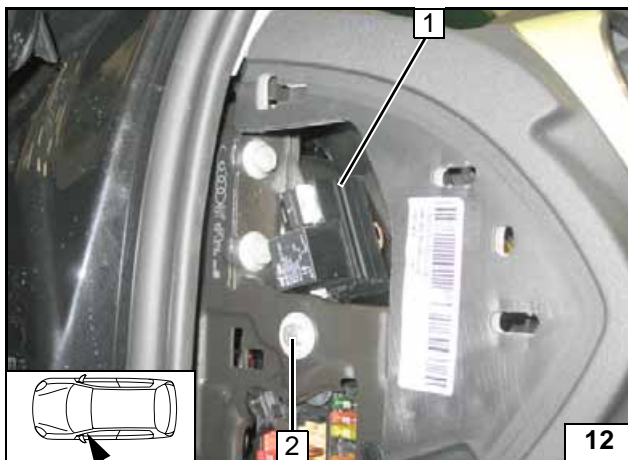

1 Fuse carrier, passenger compartment
2 M6x20 bolt, angle bracket, flanged nut, existing hole



Assemble fuse carrier in passenger compartment

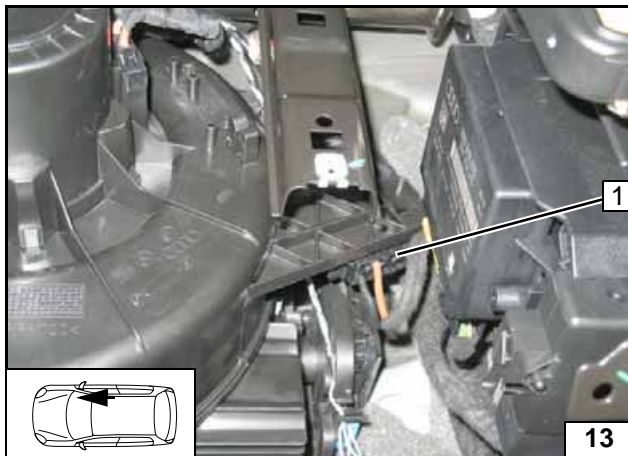

Remove connector T10c **1** from the bracket



Connector T10c

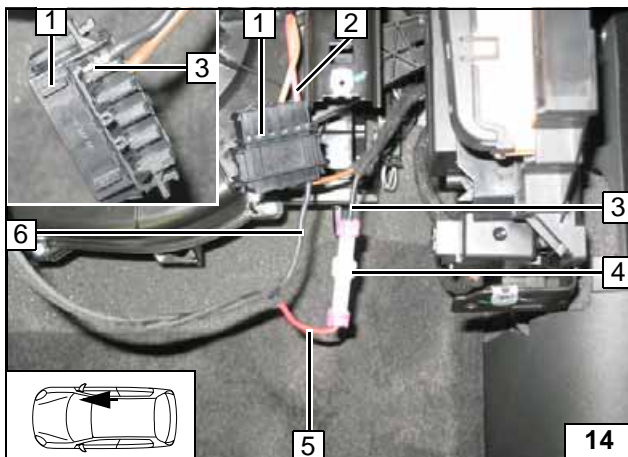

Remove black (sw) wire **3** from connector **1** T10c/1. Produce connections as shown in wiring diagram.

- 1** Connector T10c
- 2** Red/white (rt/ws) wire of fan switch
- 3** Black (sw) wire of fuse SC2
- 4** Provide connector housing with rattle protection after the assembly
- 5** Red (rt) wire from K1/87a
- 6** Black (sw) wire K1/30 in connector T10c/1



Central electrical system connection



Automatic air-conditioning fan controller



Wiring diagram

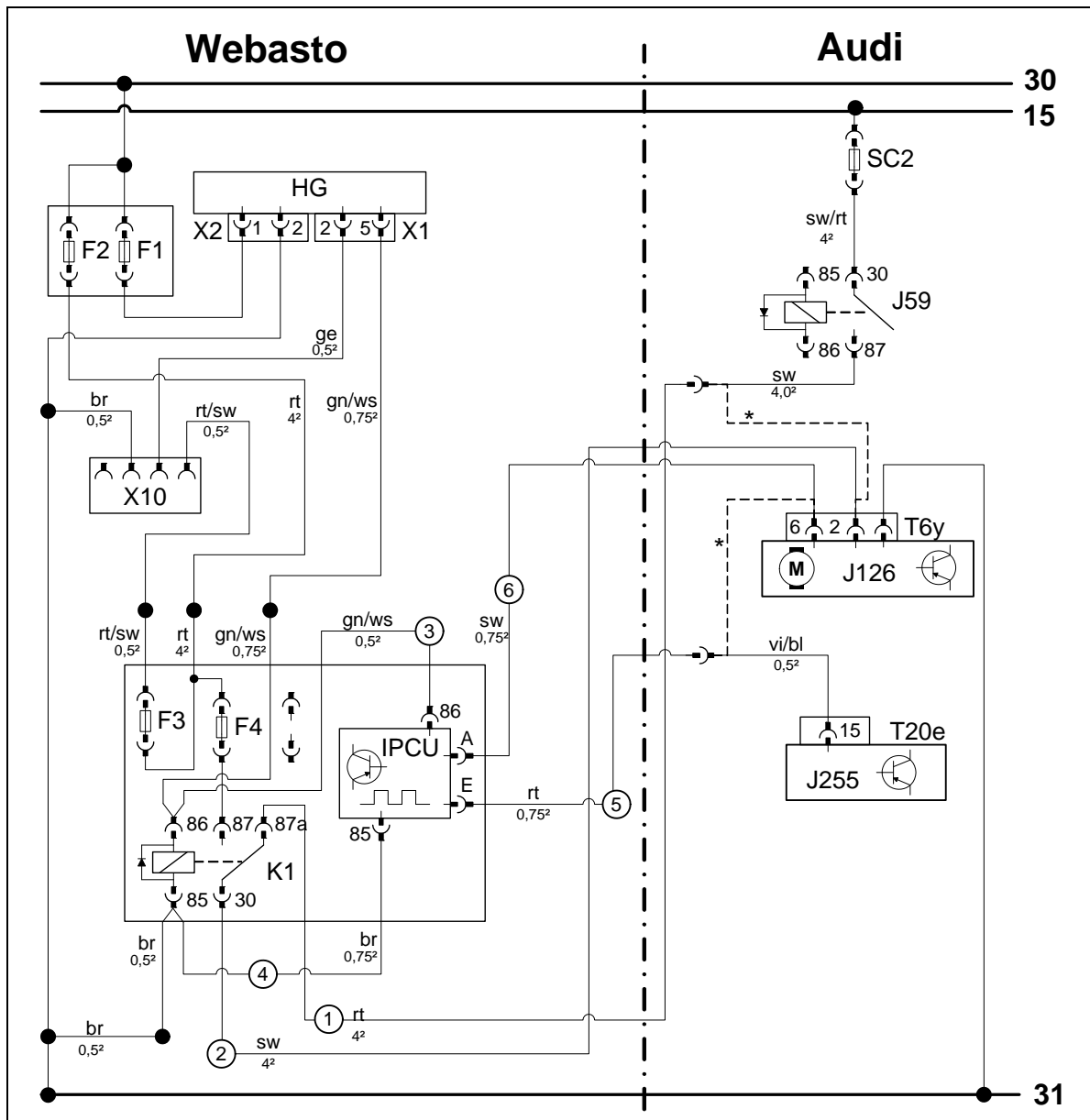

| Webasto components | | Vehicle components | | Colours and symbols | |
|-------------------------------|-----------------------------------|--------------------|-------------------|---------------------|--------------------|
| HG | Heater TT-Evo | J126 | Fan unit | rt | red |
| X1 | 6-pin heater connector | J255 | A/C control panel | ws | white |
| X2 | 2-pin heater connector | SC2 | Fuse 40A | sw | black |
| X10 | 4-pin connector Heater control | T... | Connector | br | brown |
| K1 | Fan relay | J59 | Relay X- contact | bl | blue |
| F1 | Fuse 20A | | | gn | green |
| F2 | Fuse 30A | | | ge | yellow |
| F3 | Fuse 1A | | | vi | violet |
| F4 | Fuse 25A | | | | |
| IPCU | Pulse width modulator | | | | |
| IPCU adjustment values | | | | | |
| Voltage: 3.6 V | | | | | |
| Frequency: 1,000 Hz | | | | | |
| Duty cycle: 100 % | | | | | |
| Function: High side | | | | | |
| | | | | * | Original condition |
| Wiring colours may vary. | | | | | |

Legend

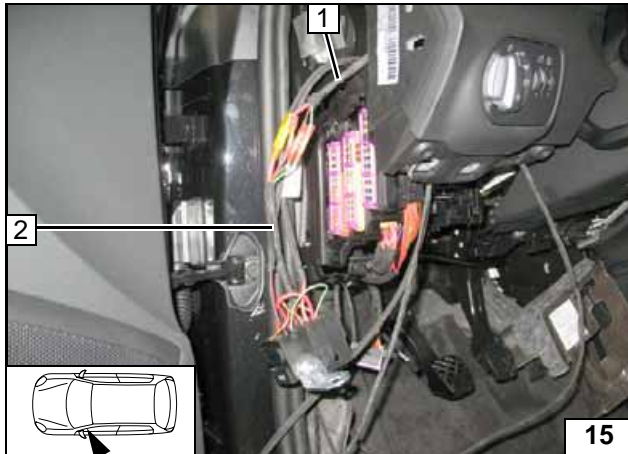

Connect the wiring harnesses of fuse holder in engine compartment **1** and interior **2** colour-matched according to circuit diagram.



Connect wiring harnesses

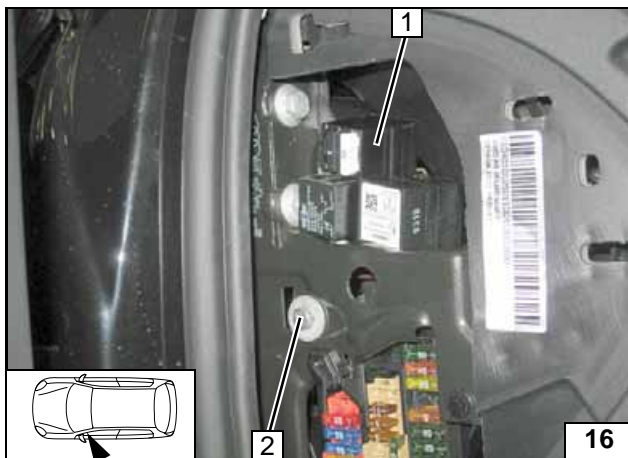

1 Fuse carrier, passenger compartment
2 M6x20 bolt, angle bracket, flanged nut, existing hole



Assemble fuse carrier in passenger compartment

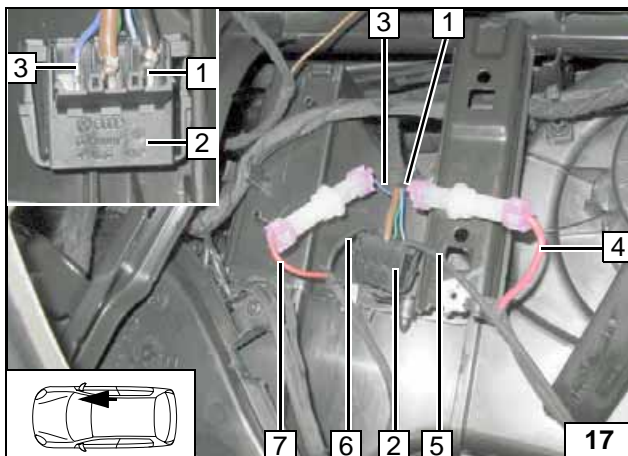

Remove black (sw) wire 4² **1** pin 2 and violet/blue (vi/bl) wire **3** pin 6 from connector T6y **2**. Produce connections as shown in wiring diagram.



Fan controller connection

1 Black (sw) wire from J59
3 Blue/violet (vi/bl) wire from J255
4 Red (rt) wire ① from K1/87a
5 Black (sw) wire ② K1/30 in connector T6y/2
6 Black (sw) wire ⑥ of IPCU/A in connector T6y/6
7 Red (rt) wire ⑦ of IPCU/E

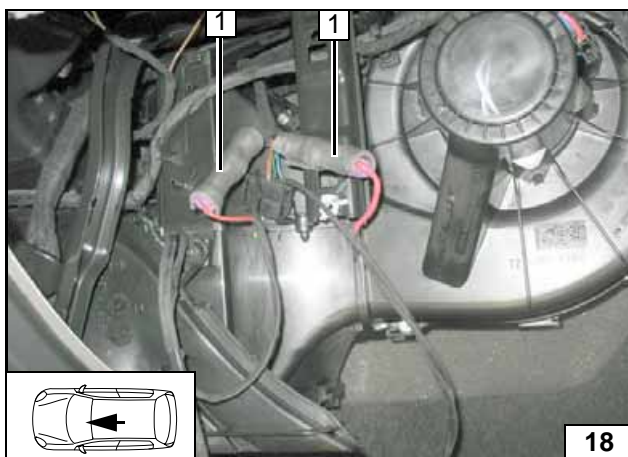

Provide connectors with rattle protection **1** (1x each).



Fan controller connection

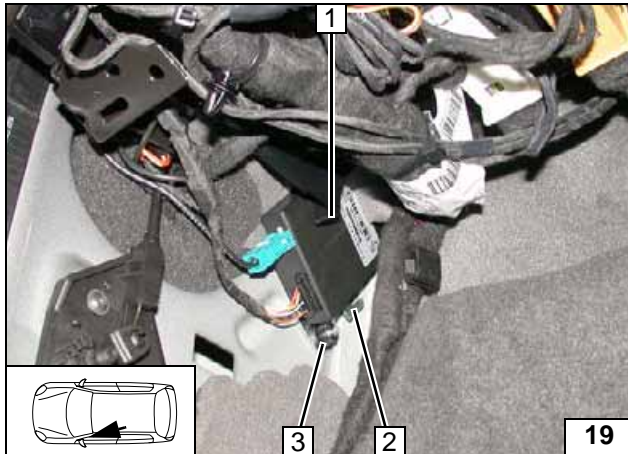

Remote option (Telestart)

- 1 Receiver, bracket
- 2 Existing stud bolt, plastic nut



Installing receiver

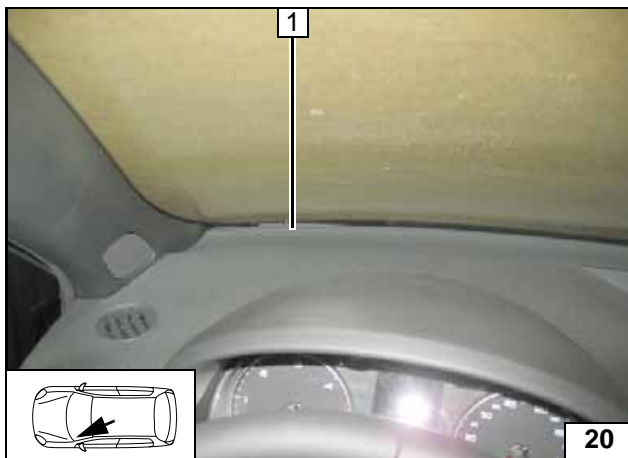

- 1 Antenna

Installing antenna

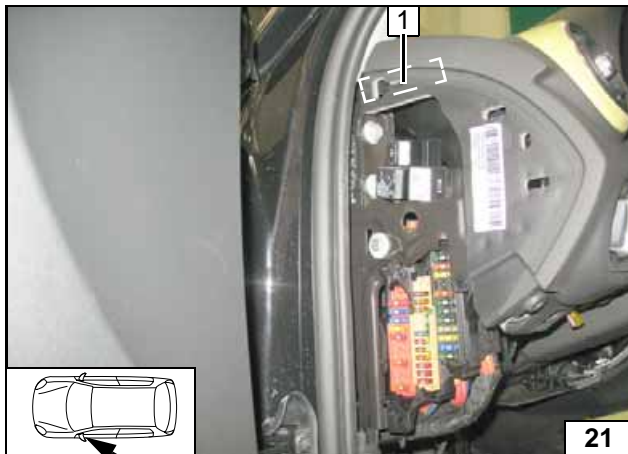

Temperature sensor T100 HTM

Fasten temperature sensor 1 with double-sided adhesive tape.



Installing temperature sensor

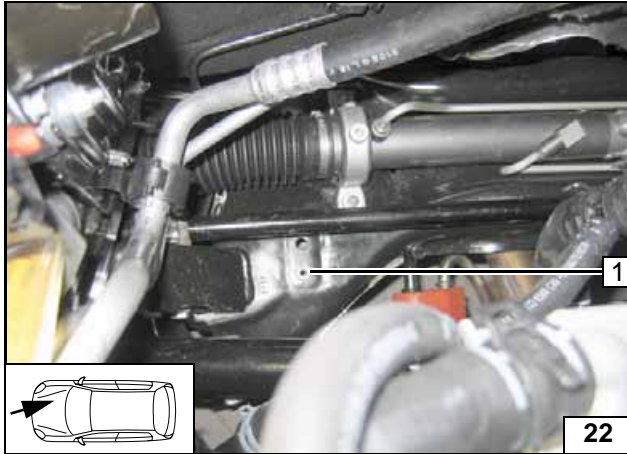
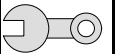

Preparing installation location

All vehicles

1 Original vehicle hole, install rivet nut



Installing rivet nut

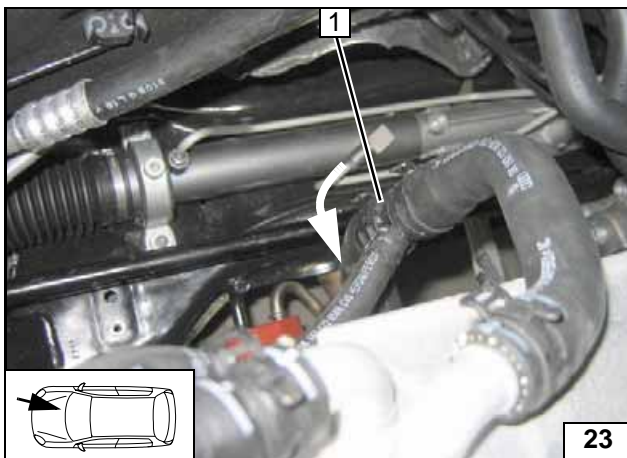

1,2 TFSI

Twist T-piece 1 according to figure.



Align T-piece

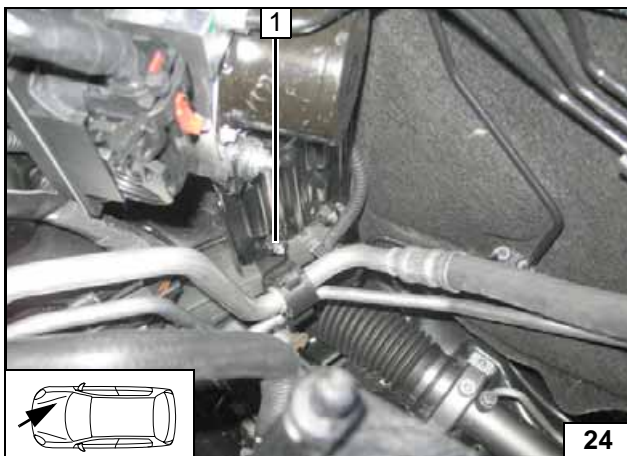

All vehicles

Remove original vehicle flanged nut 1, will be re-used later!



Remove flanged nut

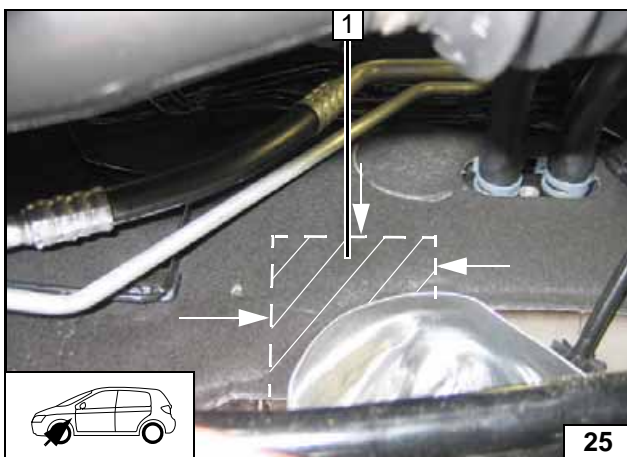

Cut out insulation mat 1 at marking.



Cutting out insulation mat

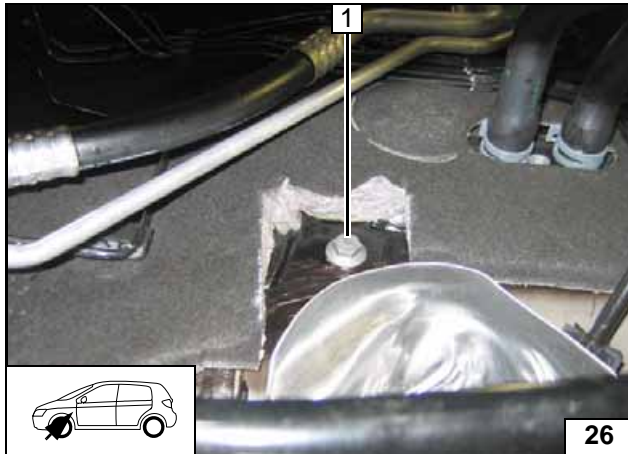
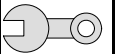

Remove original vehicle bolt 1, will be re-used later.



Removing bolt

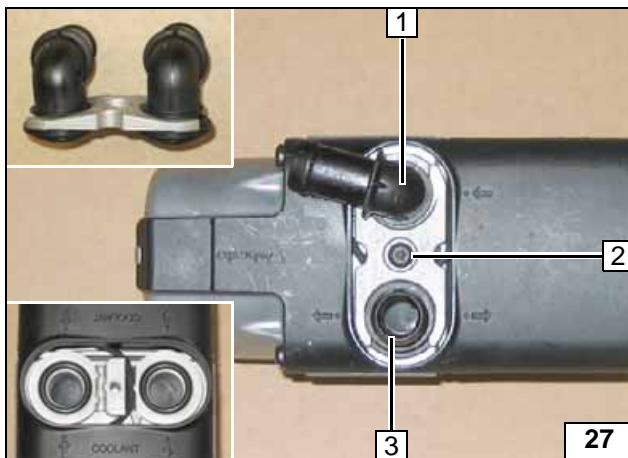

Preparing heater

- 1 90° coolant connecting piece, 18 mm dia., sealing ring]
- 2 Self-tapping screw 5x15, retaining plate, coolant connecting piece
- 3 Straight coolant connecting piece, 18 mm dia., sealing ring



Assembling coolant connecting piece

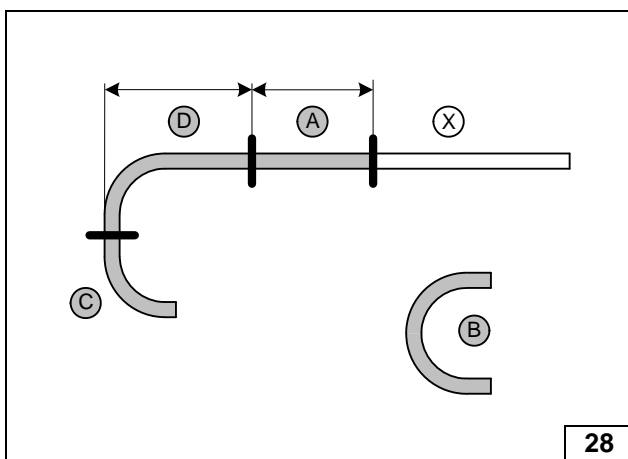

1,2 TFSI

All 180° moulded hoses = 18x18 mm dia. Discard section X.

- A = 200
- D = 200



Cut hoses to length

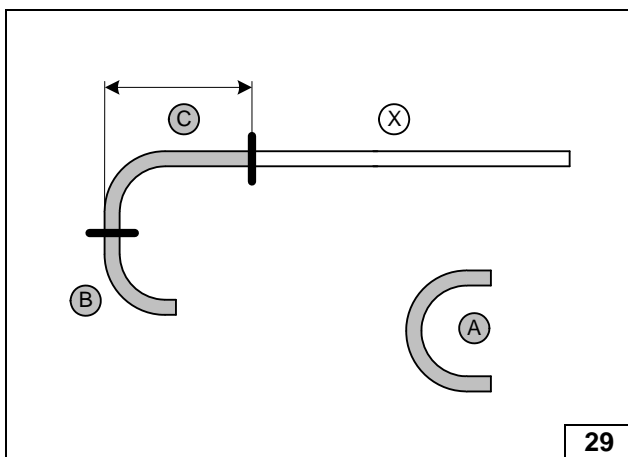

1.4 TFSI

All 180° moulded hoses = 18x18 mm dia. Discard section X.

- C = 200

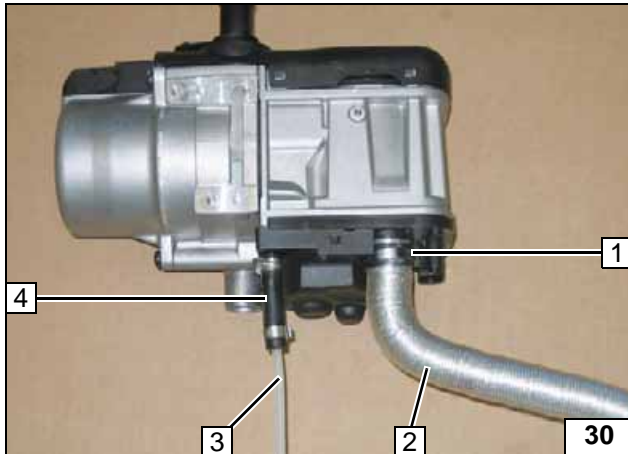
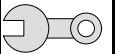

Cut hoses to length

**All vehicles**

- 1 25 mm dia. spring clip
- 2 Combustion air pipe
- 3 Fuel line
- 4 Hose section, clamp [2x]

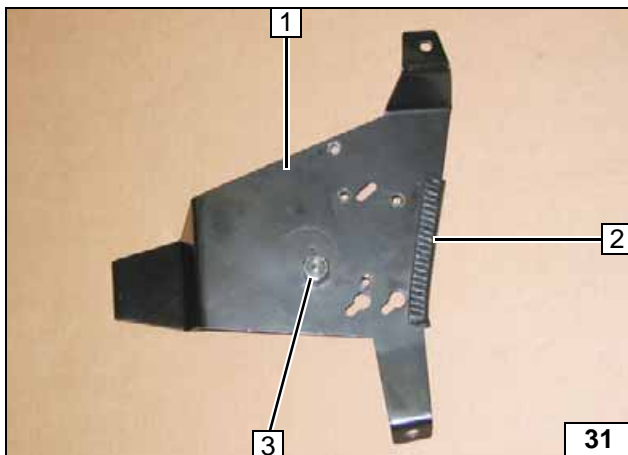
**Premounting heater**

- 1 Bracket
- 2 100 mm edge protection
- 3 M6x12 bolt, spring lockwasher, M6x20 spacer nut

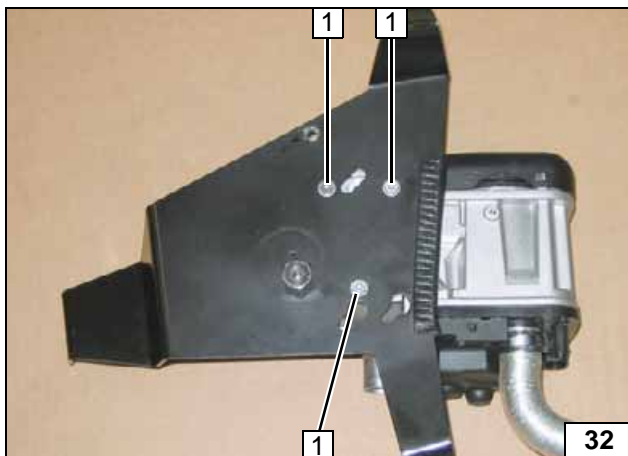
Preparing bracket

- 1 Self-tapping screw 5x13 [3x]

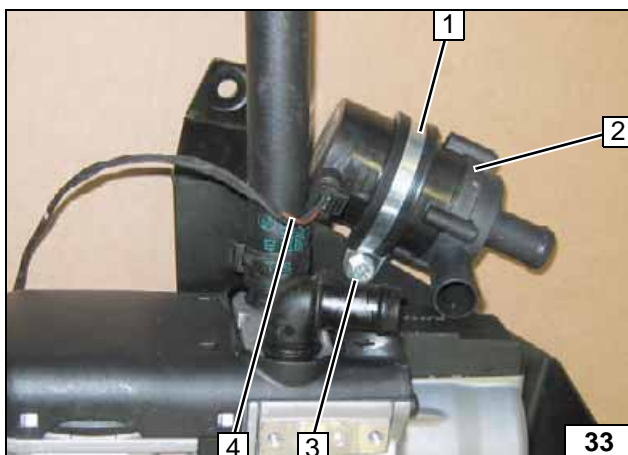
Installing bracket

Mount cable harness of circulation pump 4 on heater and circulation pump

- 1 48 mm dia. rubber-coated p-clamp
- 2 Circulating pump
- 3 M6x20 bolt, flanged nut, existing hole

**Mounting circulation pump**

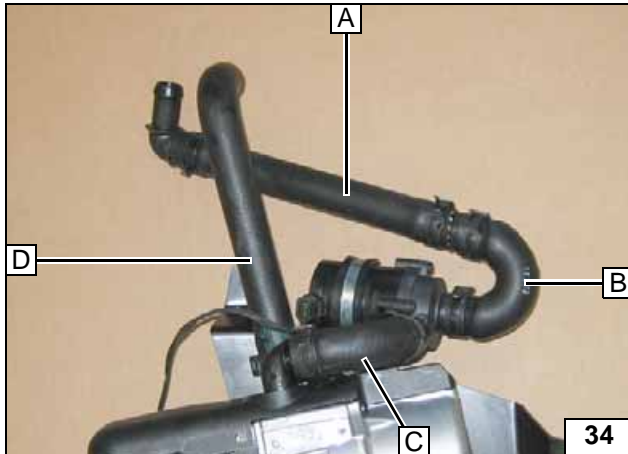
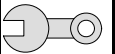

1,2 TFSI

All connecting pipes = 18x18 mm dia.
All spring clips = dia. 25 mm.



Installing hoses

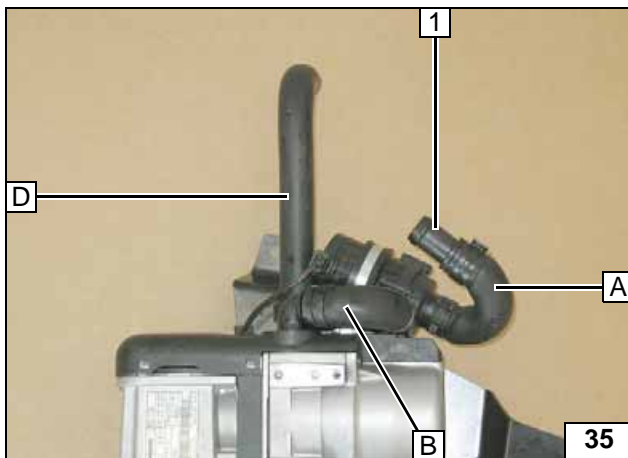

1.4 TFSI

All spring clips = dia. 25 mm!

1 Connecting pipe 18/20



Installing hoses

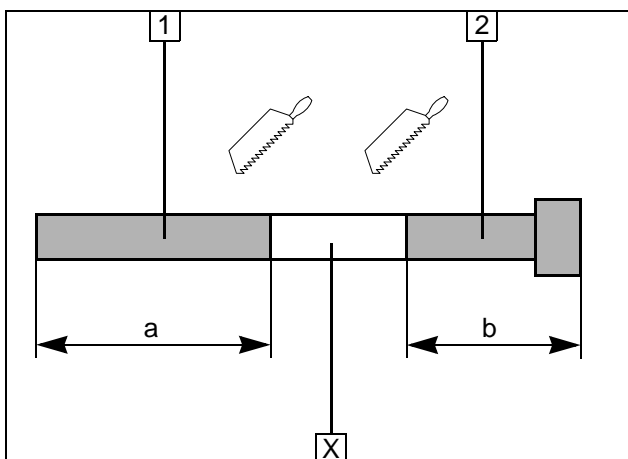

All vehicles

- 1 Exhaust pipe
a = 540
- 2 Exhaust end section
b = 100

Discard section X



Preparing exhaust pipe

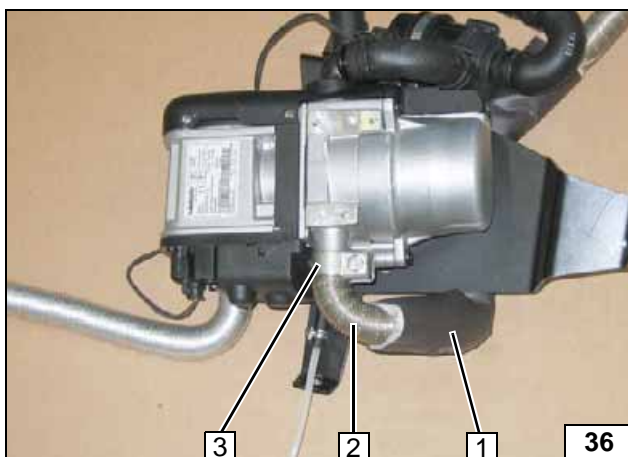

- 1 Slide on exhaust-gas insulation
- 2 Exhaust pipe
- 3 Hose clamp

Installing exhaust pipe

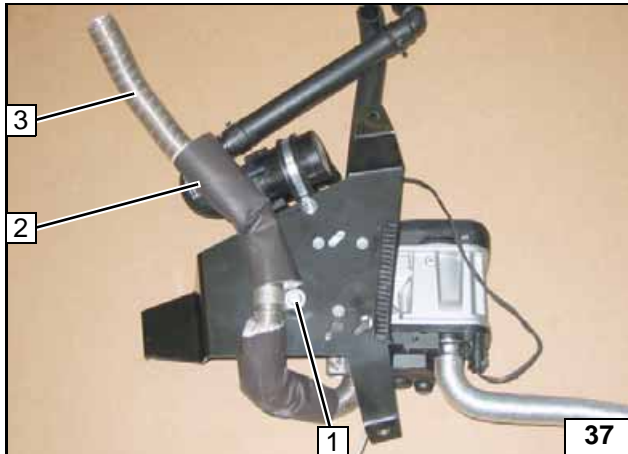
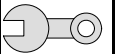
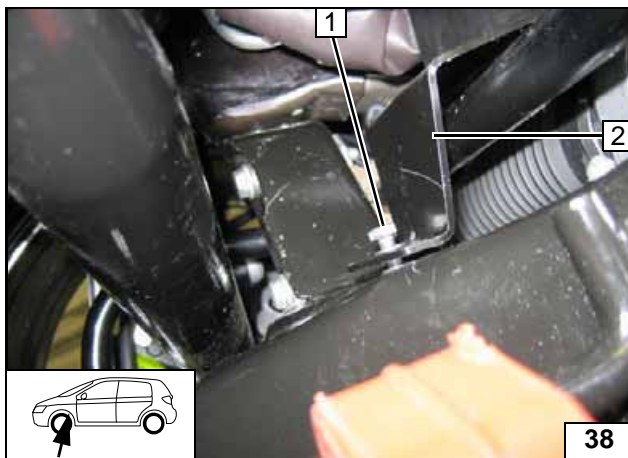

Figure shows heater for 1.2 TFSI

- 1 M6x12 bolt, spring lockwasher, p-clamp, large diameter washer
- 2 Slide on exhaust-gas insulation
- 3 Exhaust pipe



Installing exhaust pipe



Installing heater

- 1 Loosely install M6x20 bolt, spring lockwasher
- 2 Bracket



Installing heater

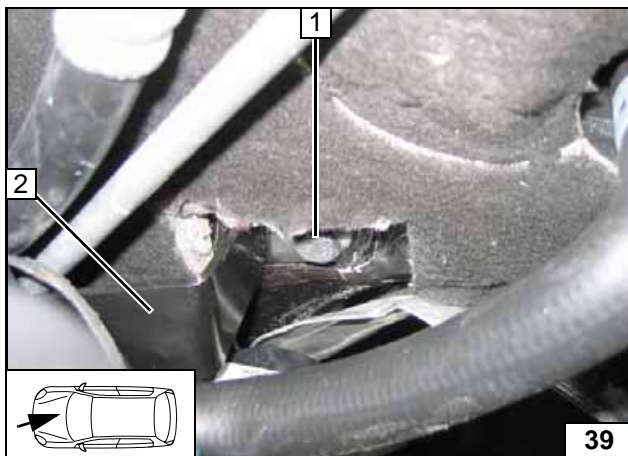

- 1 Loosely install original vehicle bolt
- 2 Bracket

Installing heater

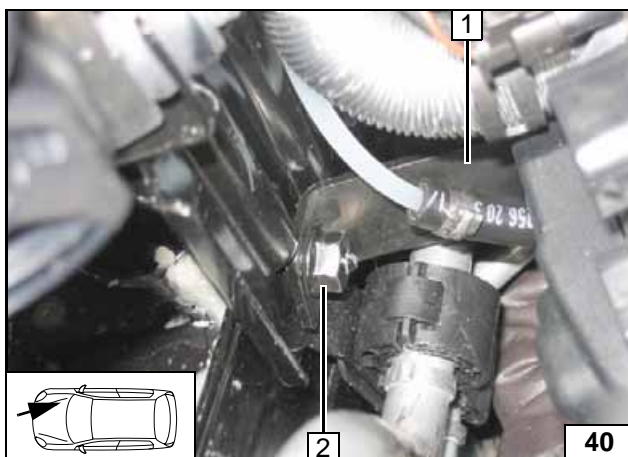

Tighten all loose screw connections!

- 1 Bracket
- 2 Original vehicle flanged nut



Installing heater

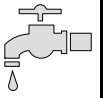

Coolant circuit 1,2 TFSI

WARNING!

Any coolant running off should be collected using an appropriate container! Install hoses so that they are kink-free! Unless specified otherwise, always fasten using cable ties. Position clamps so that no other hose can be damaged! When installing the hoses, the heater must be filled with coolant! The connection should be "inline" based on the following diagram:

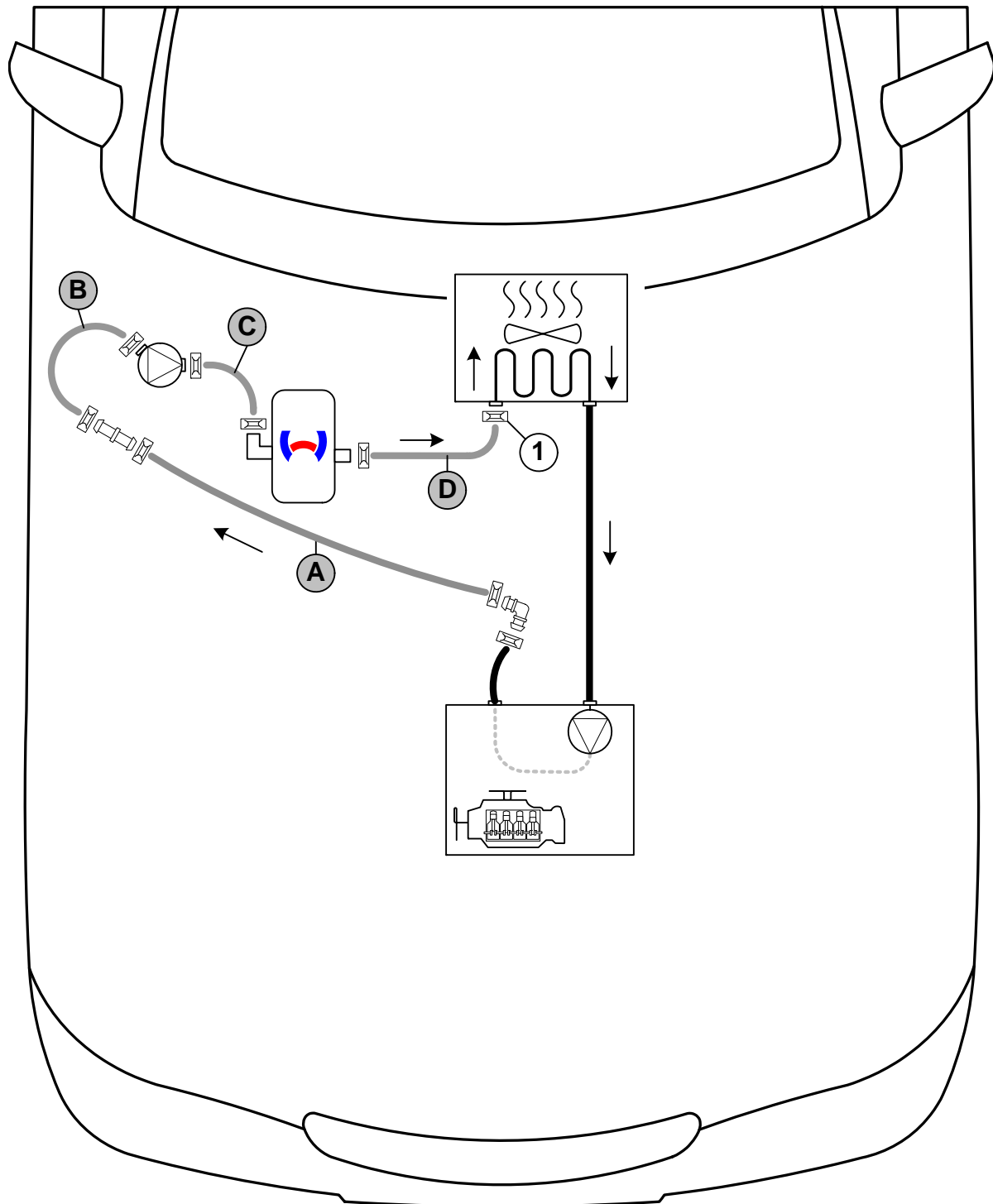

Hose installation diagram

All spring clips  = dia. 25mm! 1 = Original vehicle spring clip  .
All connecting pipes without a specific designation  and  = 18x18 mm dia.



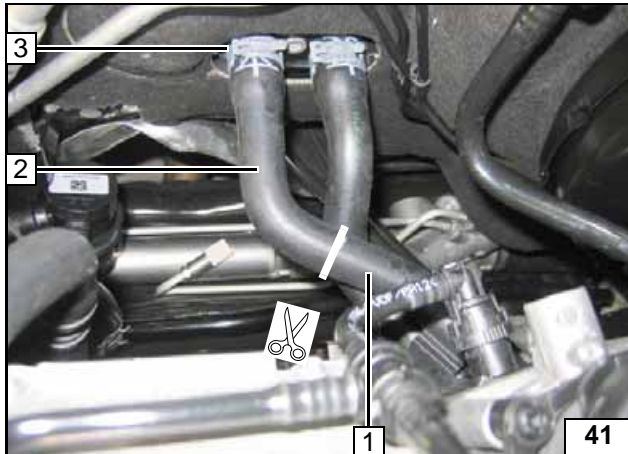

- 1 Engine outlet hose section
- 2 Remove hose section on heat exchanger inlet and discard
- 3 Original vehicle spring clip will be reused.

Cutting point

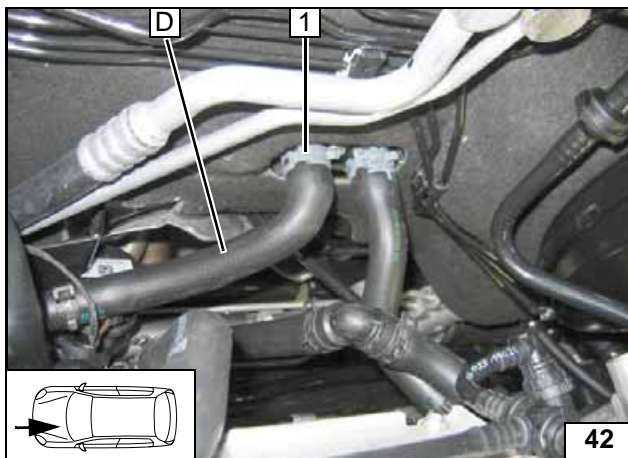

- 1 Original vehicle spring clip



Connecting heat exchanger inlet

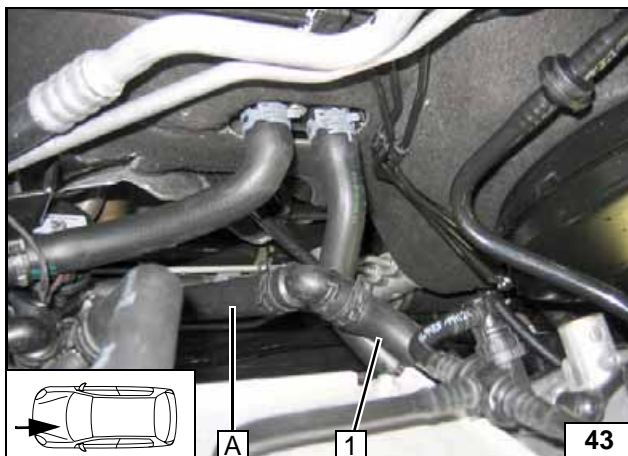

Ensure sufficient distance to neighboring components, adjust, if necessary.

- 1 Engine outlet hose section



Connecting engine outlet





Coolant circuit 1.4 TFSI

WARNING!

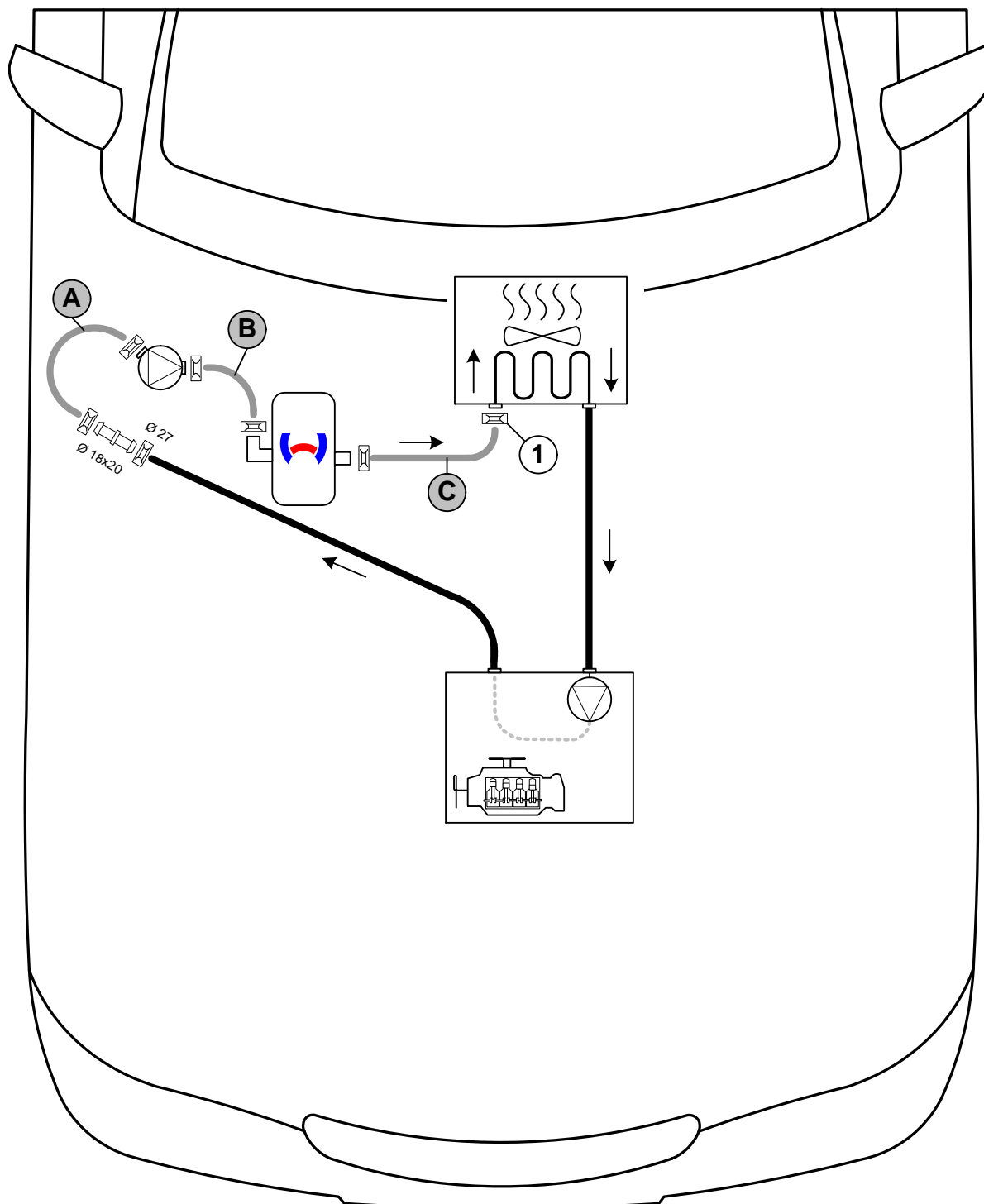
Any coolant running off should be collected using an appropriate container! Install hoses so that they are kink-free! Unless specified otherwise, always fasten using cable ties. Position clamps so that no other hose can be damaged! When installing the hoses, the heater must be filled with coolant! The connection should be "inline" based on the following diagram:



Hose installation diagram

All spring clips without a specific designation  = 25 mm dia. **1** = Original vehicle spring clip .



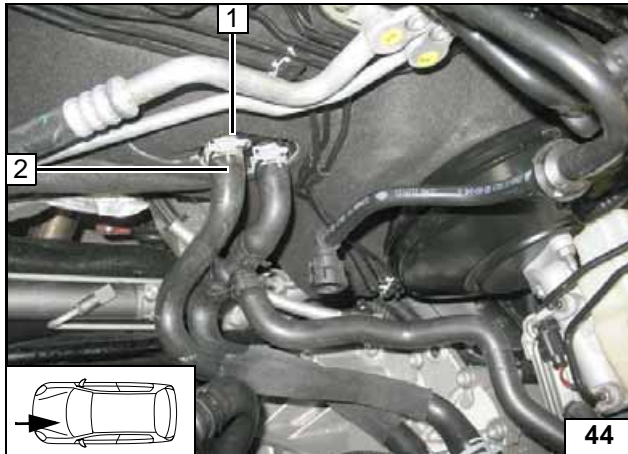
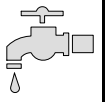

Remove hose of heat exchanger inlet 2 from connecting piece 1, spring clip will be re-used.



Cutting point

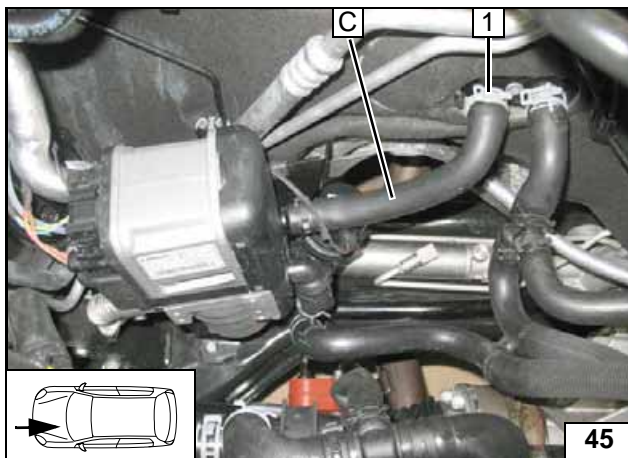

1 Original vehicle spring clip



Connecting heat exchanger inlet

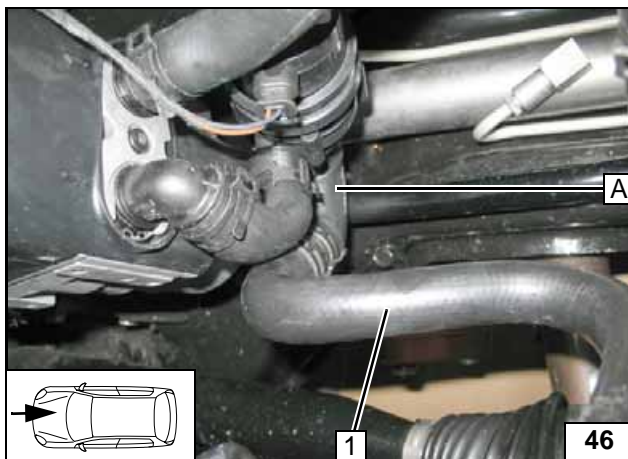

Ensure sufficient distance to neighboring components, adjust, if necessary.



1 Engine outlet hose section

Connecting engine outlet



Insert hose bracket 2 between hose A and hose 1!



Insert hose bracket

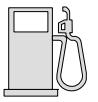

Fuel

CAUTION!

Open the vehicle's fuel tank cap, ventilate the tank and then re-close the tank lock.

Catch any fuel running off with an appropriate container.

Install fuel line and metering-pump wiring harness so that they are protected against stone impact. Unless specified otherwise, always fasten using cable ties. Mount the fuel line and wiring harness with rub protection on sharp edges.

WARNING!

The fuel line and wiring harness are routed to the metering pump in as shown in the wiring harness routing diagram.

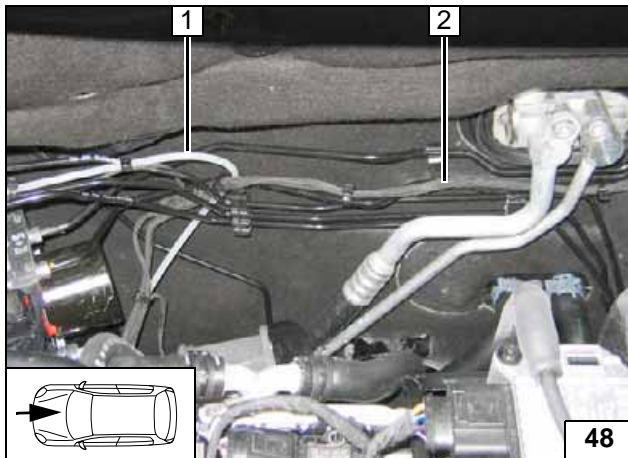

Install fuel line and wiring harness of metering pump **1** on the right side of the vehicle. Install wiring harness of heater **2** to the heater and connect!

Routing in engine compartment

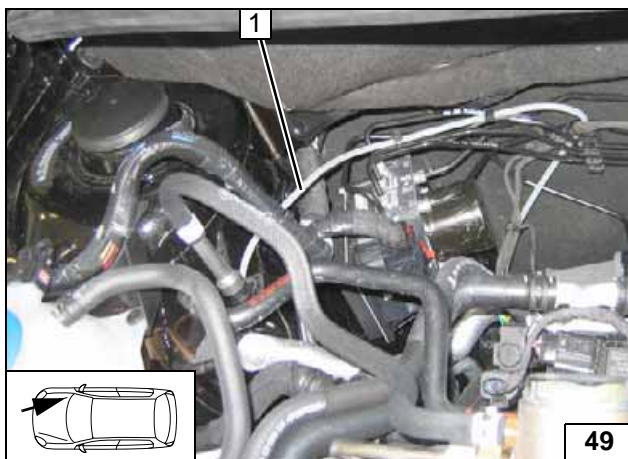

Route fuel line and wiring harness of metering pump **1** on original vehicle fuel lines for installation location of metering pump.

Routing in engine compartment



1 Fuel line, wiring harness of metering pump
2 Original vehicle pass through of fuel lines

Installing lines

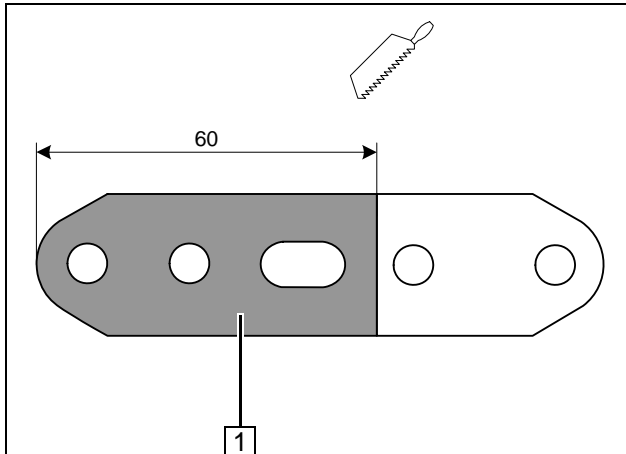

1 Perforated bracket



Cutting perforated bracket to length

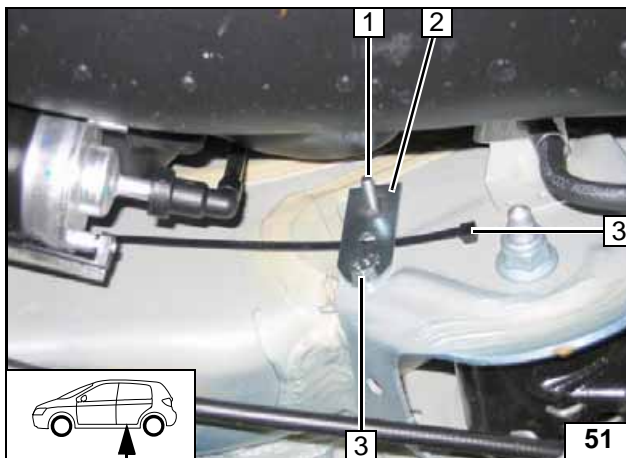

Insert cable tie 3 between perforated bracket 2 and body!

- 1 Premount M6x25 bolt, pin lock
- 3 M6x20 bolt, original vehicle hole



Installing perforated bracket

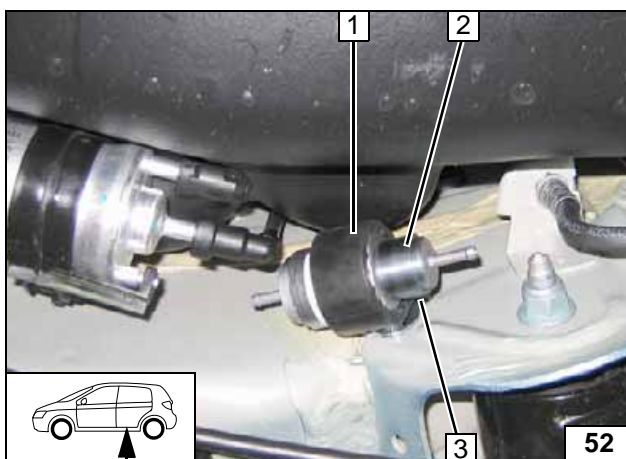

Attach mounting of metering pump 1 with flanged nut on M6x25 bolt. Close cable tie 3 around mounting of metering pump 1.

2 Metering pump



Installing metering pump

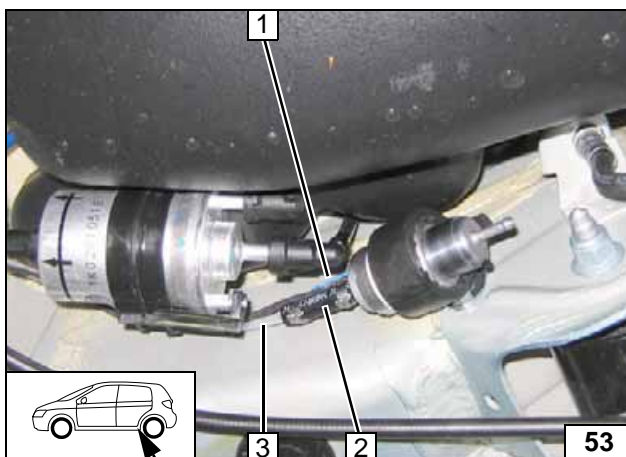

- 1 Wiring harness of metering pump, connector mounted
- 2 Hose section, 10 mm dia. clamp [2x]
- 3 Fuel line of heater



Connecting metering pump

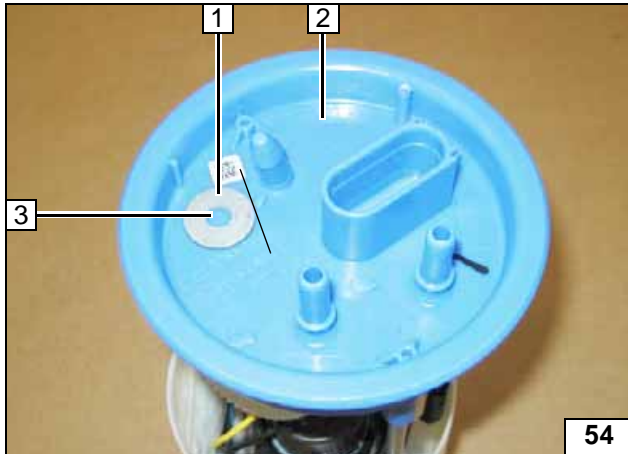

Remove fuel-tank sending unit **2** in accordance with manufacturer's specifications.

- 1** Align washer $d_a = 21.6$ mm dia.
- 3** Transfer hole pattern, 6 mm dia. hole



Removing fuel

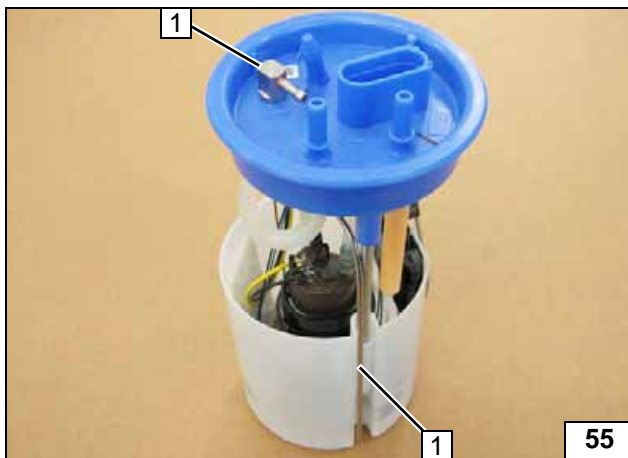

Shape fuel standpipe **1** according to template, cut to length and insert!



Installing fuel standpipe

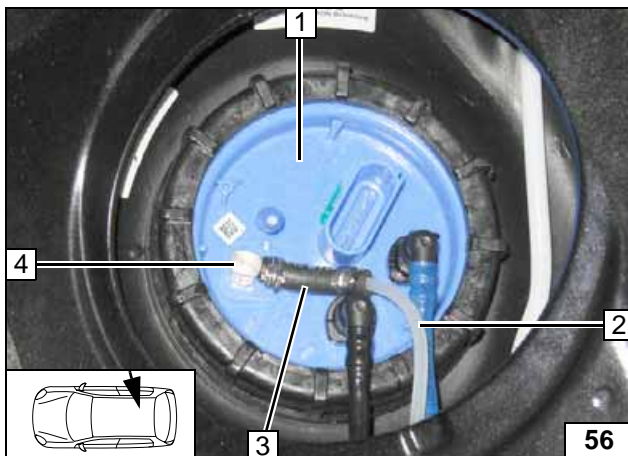

Install fuel-tank sending unit **1** in accordance with manufacturer's instructions.

- 2** Fuel line
- 3** Hose section, 10 mm dia. clamp [2x]
- 4** Fuel standpipe



Connecting fuel line

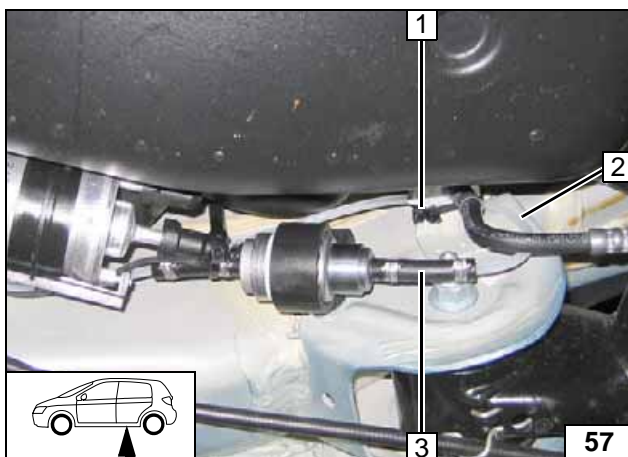

Check the position of the components; adjust if necessary. Check that they have free clearance.

- 1** Cable tie
- 2** Fuel line, fuel standpipe
- 3** Hose section, 10 mm dia. clamp [2x]



Connecting metering pump

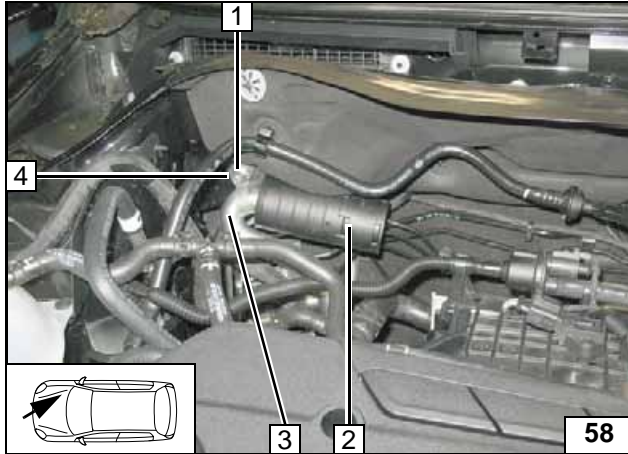
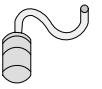

Combustion air

Figure shows 1.4 TFSI

Install coolant reservoir partition wall. Replace original vehicle bolt on position 1 with M6x50!

- 2 Silencer
- 3 Combustion air pipe
- 4 M6x50 bolt, spring lockwasher, p-clamp, 20mm shim, original vehicle threaded hole



**Installing
silencer**

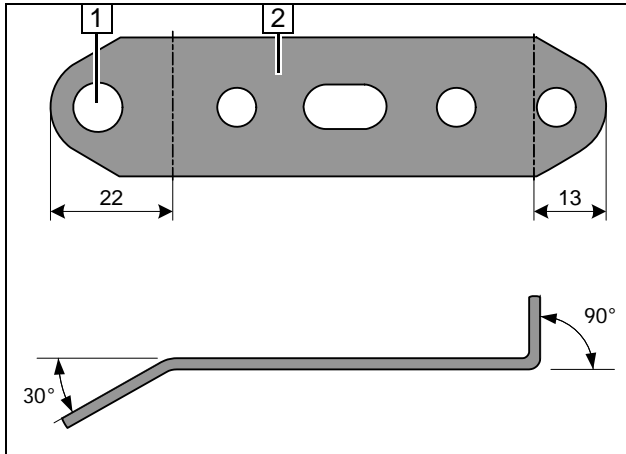
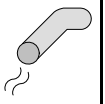

Exhaust gas

1.2 TFSI

Drill perforated bracket 2 on position 1 to 8.5 mm dia. and angle down.



Preparing perforated bracket

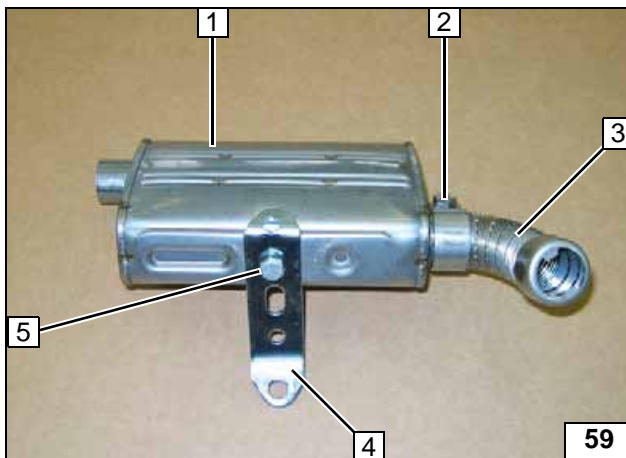

- 1 Silencer
- 2 Hose clamp
- 3 Exhaust end section
- 3 Perforated bracket
- 5 M6x16 bolt, spring lockwasher

Preassembling silencer

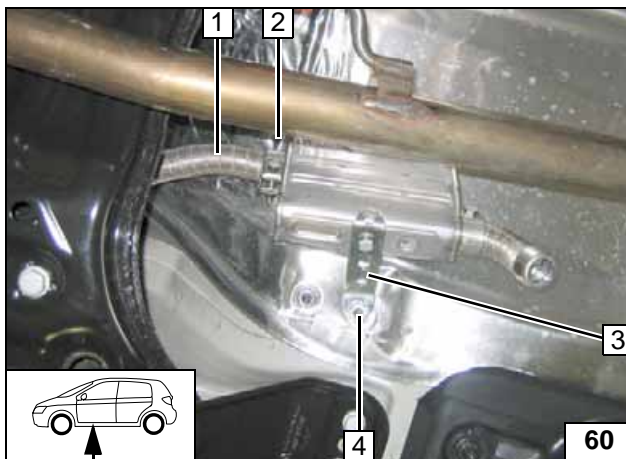

Ensure sufficient distance to neighboring components, adjust, if necessary.

- 1 Exhaust pipe
- 2 Hose clamp
- 3 Perforated bracket
- 4 Flanged nut M8, original vehicle stud bolt



Installing silencer

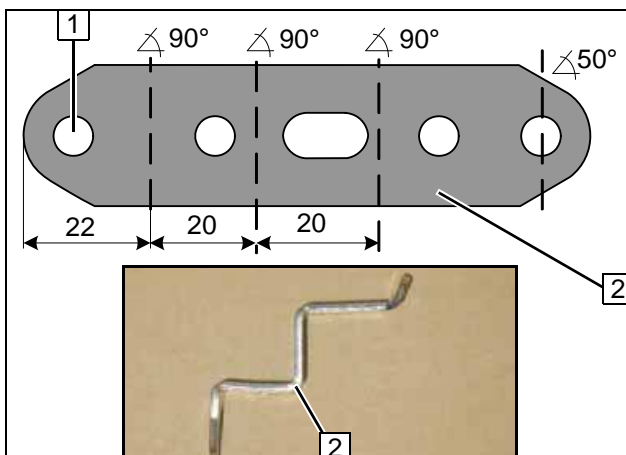

1.4 TFSI

Drill perforated bracket 2 on position 1 to 8.5 mm dia. and angle down.



Preparing perforated bracket

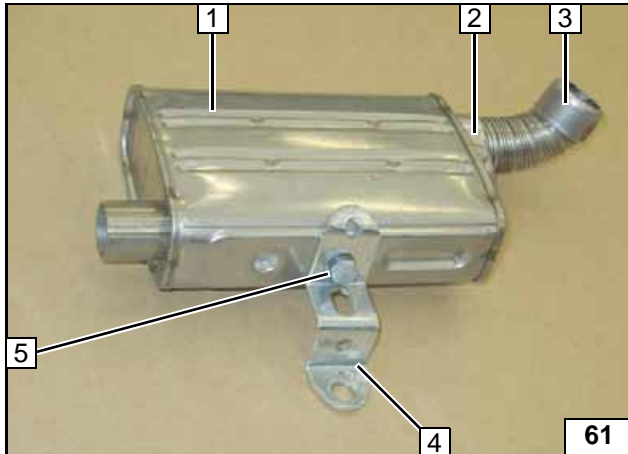
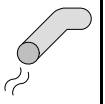

- 1 Silencer
- 2 Hose clamp
- 3 Exhaust end section
- 3 Perforated bracket
- 5 M6x16 bolt, spring lockwasher

Preassembling silencer

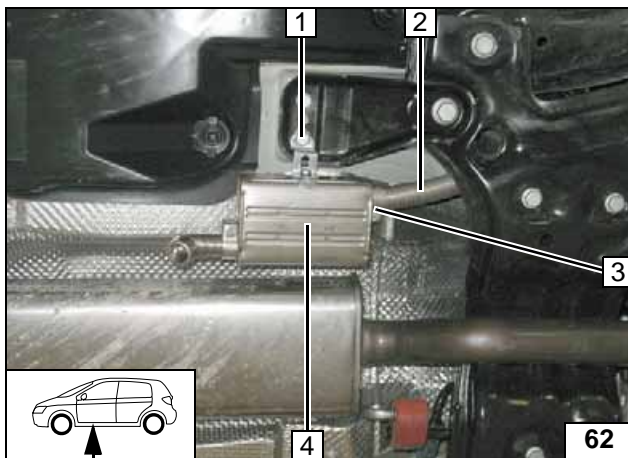

Ensure sufficient distance to neighboring components, adjust, if necessary.



- 1 Original vehicle bolt
- 2 Exhaust pipe
- 3 Hose clamp
- 4 Silencer

Installing silencer

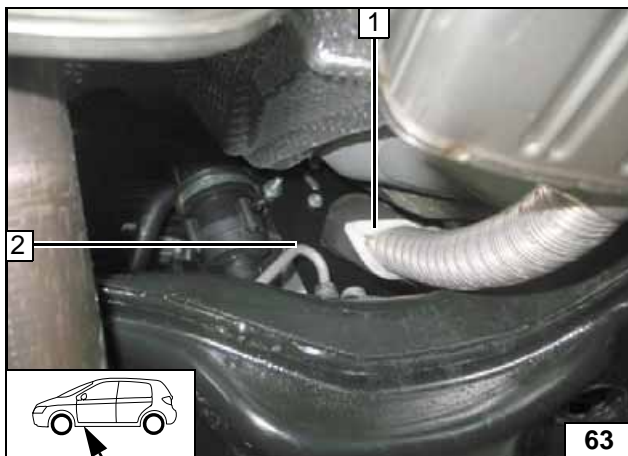

All vehicles

Ensure sufficient distance to neighboring components, adjust, if necessary.



- 1 Exhaust pipe
- 2 Pipe of power steering

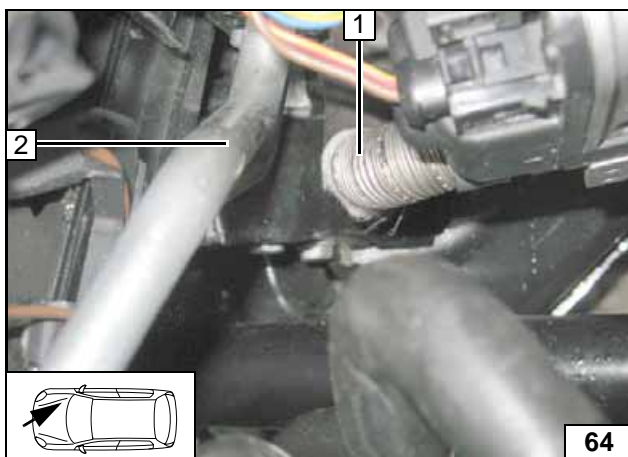

Ensure sufficient distance to neighboring components, adjust, if necessary.



- 1 Exhaust pipe
- 2 Pipe of air conditioning system

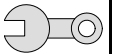

Final Work

WARNING!

Reassemble the disassembled components in reverse order. Check all hoses, clamps and all electrical connections for firm seating. Secure all loose cables using cable ties. Only use manufacturer-approved coolant. Spray the heater components with anti-corrosion wax (Tectyl 100K, Order No. 111329).

- Connect the battery
- Fill and bleed the coolant circuit according to the vehicle manufacturer's specifications.
- Set the digital timer.
- Make settings on A/C control panel according to the "Operating Instructions for End Customer".
- Place the "Switch off parking heater before refueling" signboard in the area of the filler neck

For initial start-up and function check, see installation instructions

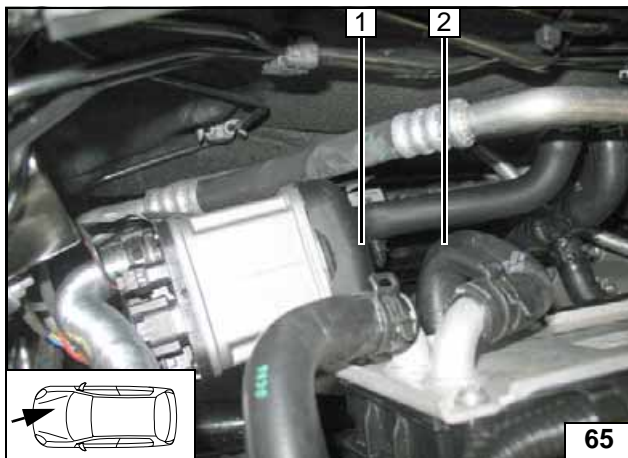

1.4 TFSI

After the assembly of the intake bridge, check for sufficient distance to adjacent components. Align original vehicle hoses 2.

1 Heater



Webasto
Feel the drive

Webasto AG
Postfach 80
D-82132 Stockdorf / Germany
National Hotline: 01805 93 22 78
(14 Cent aus dem deutschen Festnetz)
Hotfax: 0395 5592 353
Hotmail: hotline@webasto.de
<http://www.webasto.de>

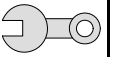

Template for fuel standpipe

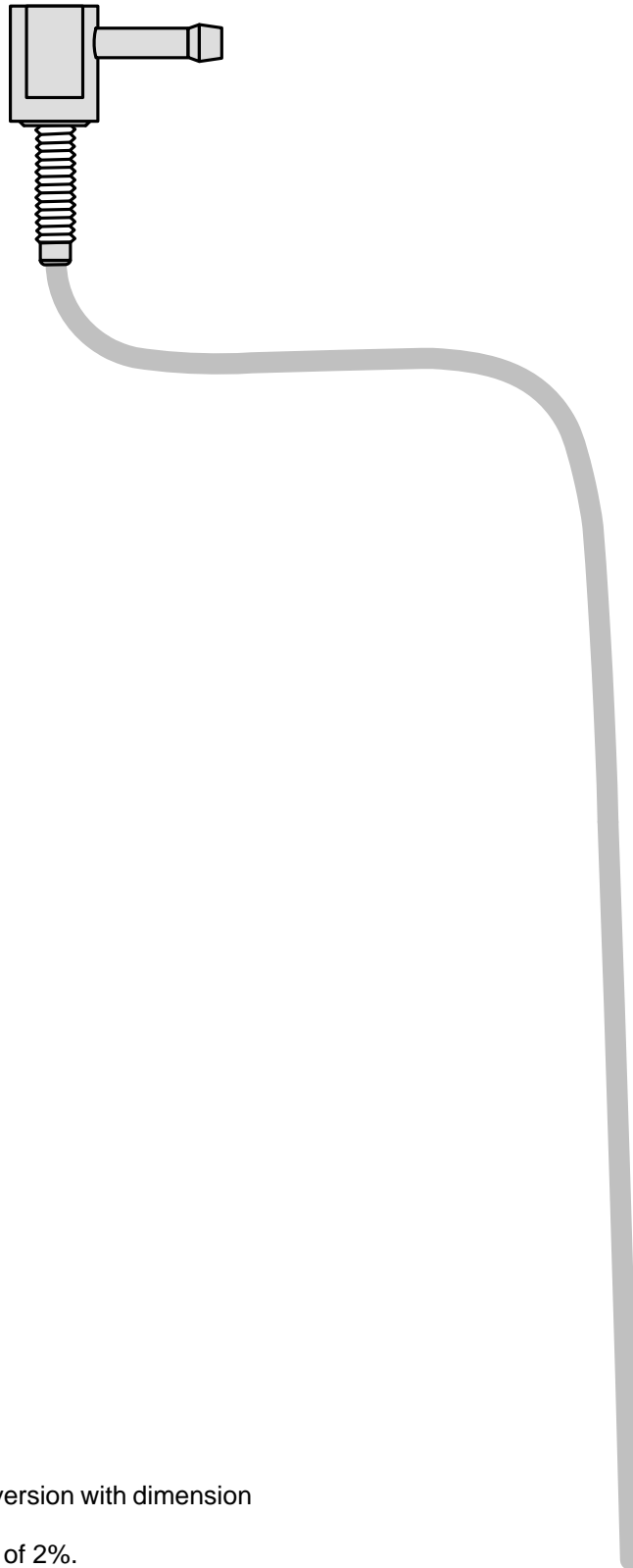

Scale 1:1

Compare the size of the printed version with dimension lines.
Permitted tolerance a maximum of 2%.

Set the printer settings to "no margin" or "minimize margins" and 100% of the normal size.

Operating Instructions for End Customer



Please remove page and add to the vehicle operating instructions.

Note:

We recommend matching the heating time to the driving time.

Heating time = driving time

Example:

For a driving time of approx. 20 min. (in one direction), we recommend not exceeding a switch-on time of 20 min.

Before parking the vehicle, make the following settings:



- 1 Set temperature to "max."
- 2 Set fan to level "1", or possibly "2"
- 3 Air outlet to windscreen

Manual air conditioning system



The fan speed does not have to be set!

- 1 Set temperature to "HI"
- 2 Air outlet to windscreen



Automatic air-conditioning