

# Water Heater

## Thermo Top Evo Parking Heater



# Installation Documentation

## Ford Focus / C-Max / Grand C-Max

### Validity

Manufacturer	Model	Type	EG BE No. / ABE
Ford	Focus	DYB	e13 * 2007 / 46 * 1138 * ...
Ford	C-Max	DXA	e13 * 2007 / 46 * 1103 * ...
Ford	Grand C-Max	DXA	e13 * 2007 / 46 * 1103 * ...

### Ford Focus

Motorisation	Fuel	Transmission type	Output in kW	Displacement in cm <sup>3</sup>	Engine code
1.6 TDCi	Diesel	SG	70	1560	T3
1.6 TDCi	Diesel	SG	85	1560	T1

### Ford C-Max / Grand C-Max

Motorisation	Fuel	Transmission type	Output in kW	Displacement in cm <sup>3</sup>	Engine code
1.6 TDCi	Diesel	SG	70	1560	T3
1.6 TDCi	Diesel	SG	85	1560	T1

SG = manual transmission

**From model year 2011 up to model year 2014**

**Left-hand drive vehicle**

**Verified equipment variants:** Manual / automatic air-conditioning system  
 Headlight washer system  
 Front fog lights  
 Automatic Start-Stop system

**Not verified:** Passenger compartment monitoring

**Total installation time:** approx. 9.5 hours

## Table of Contents

Validity	1	Automatic Air-Conditioning Wiring Diagram	14
Necessary Components	2	Automatic Air-Conditioning Fan Controller	15
Installation Overview	2	Telestart Focus Option	18
Information on Total Installation Time	2	Telestart C-Max / Grand C-Max Option	18
Information on Operating and Installation Instructions	3	Preparing Installation Location	20
Information on Validity	4	Preparing Heater	20
Technical Information	4	Installing Heater	23
Explanatory Notes on Document	4	Coolant Circuit	24
Preliminary Work	5	Combustion Air	26
Heater Installation Location	5	Fuel	27
Preparing Electrical System	6	Exhaust Gas	31
Electrical System	9	Final Work	32
Wiring Harness Routing for Focus	9	Operation of Manual A/C for Focus	33
MultiControl CAR Focus Option	9	Operation of Manual A/C for C-Max / Grand C-Max	34
Wiring Harness Routing for C-Max / Grand C-Max	10	Operation of Automatic A/C for Focus	35
MultiControl CAR C-Max / Grand C-Max Option	10	Operation of Automatic A/C for C-Max / Grand C-Max	36
Wiring Diagram for Manual Air-Conditioning	11		
Manual Air-Conditioning Fan Controller	12		

## Necessary Components

- Basic delivery scope of *Thermo Top Evo* according to price list
- Installation kit for Ford Focus / C-Max / Grand C-Max 2011 Diesel: **1316980A**
- Heater control in accordance with price list and upon consultation with end customer
- In case of Telestart, indicator lamp in accordance with price list and in consultation with end customer
- In case of MultiControl CAR installation: Timer cable extension: **1319724\_**
- For MultiControl CAR installation in case of Focus: MultiControl installation frame: **9030077\_**

### Installation instructions:

- Arrange for the vehicle to be delivered with the tank only about ¼ full.
- The installation location of the push button in case of Telestart or ThermoCall should be confirmed with the end customer.
- Depending on the space required and the vehicle manufacturer's instructions, we recommend the use of a vehicle battery with a higher electrical capacity.

## Installation Overview

### Legend:

1. Heater
2. Engine compartment fuse holder
3. Relay and fuse holder for passenger compartment, manual and automatic A/C **Focus**
4. PWM GW, automatic A/C **Focus**
5. Passenger compartment relay and fuse holder, manual and automatic A/C **C-Max / Grand C-Max**
6. PWM GW, automatic A/C **C-Max / Grand C-Max**
7. Circulating pump
8. MultiControl CAR
9. Metering pump

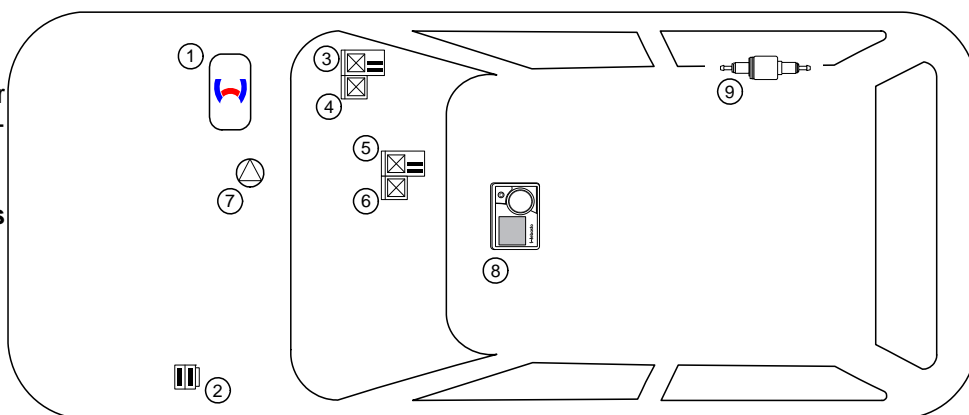

## Information on Total Installation Time

The total installation time includes the time needed for mounting and demounting the vehicle-specific components, the heater specific installation time and all other times required for the system integration and initial start-up of the heater.

The total installation time may vary for vehicle equipment other than provided.

## Information on Operating and Installation Instructions

### 1 Important information (not complete)

#### 1.1 Installation and repair



The improper installation or repair of Webasto heating and cooling systems can cause fire or the leakage of deadly carbon monoxide, leading to serious injury or death.



To install and repair Webasto heating and cooling systems you need to have completed a special company training course and have the appropriate technical documentation, special tools and special equipment.



Installation and repair may ONLY be carried out by persons trained and certified in a Webasto training course. NEVER try to install or repair Webasto heating or cooling systems if you have not completed a Webasto training course, you do not have the necessary technical skills and you do not have the technical documentation, tools and equipment available to ensure that you can complete the installation and repair work properly.

Only use genuine Webasto parts. See the Webasto air and water heaters accessories catalogue for this purpose.

#### 1.2 Operation

To ensure safe operation, we recommend having the heater checked every two years by an authorised Webasto dealer, especially when used over a long period and/or under extreme environmental conditions.

Do not operate the heater in closed rooms due to the danger of poisoning and suffocation.

Always switch off the heater before refuelling.

The heater may only be used with the prescribed fuel diesel (DIN EN 590) or petrol (DIN EN 228).

The heater may not be cleaned with a high-pressure cleaner.

#### 1.3 Please note

ALWAYS follow all Webasto installation and operating instructions and observe all warnings.

To become familiar with and understand all functions and properties of the heater, the operating instructions must be read carefully and observed at all times.

For proper, safe installation and repair work, the installation instructions with all warnings and safety information must be carefully read and observed at all times. Please always contact a workshop authorised by Webasto for all installation and repair work.

#### Important

**Webasto shall assume no liability for defects, damage and injuries resulting from a failure to observe the installation, repair and operating instructions of the information contained in them.**

**This liability exclusion particularly applies to improper installations and repairs, installations and repairs by untrained persons or in the case of a failure to use genuine spare parts.**

**The liability due to culpable disregard to life, limb or health and due to damage or injuries caused by a wilful or reckless breach of duty remain unaffected, as does the obligatory product liability.**

Installation should be carried out according to the general, standard rules of technology. Unless specified otherwise, fasten hoses, lines and wiring harnesses to original vehicle lines and wiring harnesses using cable ties. Insulate loose wire ends and tie back. Connectors on electronic components must audibly snap into place during assembly.

Sharp edges should be fitted with rub protection. Spray unfinished body areas, e.g. drilled holes, with anti-corrosion wax (Tectyl 100K).

Observe the instructions and guidelines of the respective vehicle manufacturer for demounting and mounting vehicle specific components!

The initial startup is to be executed with the Webasto Thermo Test Diagnosis.

When installing a programmable control module (e.g. a PWM Gateway), the corresponding settings must be checked or adjusted.

### 2 Statutory regulations governing installation

Guidelines	Thermo Top Evo
Heating Directive ECE R122	E1 00 0258
EMC Directive ECE R10	E1 04 5627

#### Note

The regulations of these guidelines are binding in the scope of the Directive 70/156/EEC and/or 2007/46/EC (for new vehicle models from 29/04/2009) and should also be observed in countries in which there are no special regulations.

#### Important

Failure to follow the installation instructions will result in the invalidation of the type approval for the heater and therefore invalidation of the general **homologation of the vehicle**.

#### Note

The heater is licensed in accordance with paragraph 19, section 3, No. 2b of the StVZO (German Road Traffic Licensing Authority).

### 2.1 Excerpt from ECE regulation 122 (heating system) paragraph 5 for the installation of the heater

Beginning of excerpt.

#### ANNEX VII

#### REQUIREMENTS FOR COMBUSTION HEATERS AND THEIR INSTALLATION

##### 1. GENERAL REQUIREMENTS

1.7.1. A clearly visible tell-tale in the operator's field of view shall inform when the combustion heater is switched on or off.

##### 2. VEHICLE INSTALLATION REQUIREMENTS

###### 2.1. Scope

2.1.1. Subject to paragraph 2.1.2. combustion heaters shall be installed according to the requirements of this Annex.

2.1.2. Vehicles of category O having liquid fuel heaters are deemed to comply with the requirements of this Annex.

###### 2.2. Positioning of heater

2.2.1. Body sections and any other components in the vicinity of the heater must be protected from excessive heat and the possibility of fuel or oil contamination.

2.2.2. The combustion heater shall not constitute a risk of fire, even in the case of overheating. This requirement shall be deemed to be fulfilled if the installation ensures an adequate distance to all parts and suitable ventilation, by the use of fire resistant materials or by the use of heat shields.

2.2.3. In the case of M2 and M3 vehicles, the heater must not be positioned in the passenger compartment. However, an installation in an effectively sealed envelope which also complies with the conditions in paragraph 2.2.2 may be used.

2.2.4. The label referred to in paragraph 1.4 or a duplicate, must be positioned so that it can be easily read when the heater is installed in the vehicle.

2.2.5. Every reasonable precaution should be taken in positioning the heater to minimise the risk of injury and damage to personal property.

###### 2.3. Fuel supply

2.3.1. The fuel filler must not be situated in the passenger compartment and must be provided with an effective cap to prevent fuel spillage.

2.3.2. In the case of liquid fuel heaters, where a supply separate to that of the vehicle is provided, the type of fuel and its filler point must be clearly labelled.

2.3.3. A notice, indicating that the heater must be shut down before refuelling, must be affixed to the fuelling point. In addition a suitable instruction must be included in the manufacturer's operating manual.

###### 2.4. Exhaust system

2.4.1. The exhaust outlet must be located so as to prevent emissions from entering the vehicle through ventilators, heated air inlets or opening windows.

###### 2.5. Combustion air inlet

2.5.1. The air for the combustion chamber of the heater must not be drawn from the passenger compartment of the vehicle.

2.5.2. The air inlet must be so positioned or guarded that blocking by rubbish or luggage is unlikely.

###### 2.6. Heating air inlet

2.6.1. The heating air supply may be fresh or recirculated air and must be drawn from a clean area not likely to be contaminated by exhaust fumes emitted either by the propulsion engine, the combustion heater or any other vehicle source.

2.6.2. The inlet duct must be protected by mesh or other suitable means.

###### 2.7. Heating air outlet

2.7.1. Any ducting used to route the hot air through the vehicle must be so positioned or protected that no injury or damage could be caused if it were to be touched.

2.7.2. The air outlet must be so positioned or guarded that blocking by rubbish or luggage is unlikely.

End of excerpt.

In multilingual versions the German language is binding.

## Information on Validity

This installation documentation applies to Ford Focus / C-Max / Grand C-Max Diesel vehicles - for validity, see page 1 - from model year 2011 and later, assuming technical modifications to the vehicle do not affect installation, any liability claims excluded. Depending on the vehicle version and equipment, modifications may be necessary during installation with respect to this 'installation documentation'.

Vehicle and engine types, equipment variants and other specifications not listed in this installation documentation have not been tested. However, installation according to this installation documentation may be possible.

## Technical Information

### Special Tools

- Hose clamp pliers for auto-tightening hose clamps
- Hose clamp pliers for Clic hose clamps of type W
- Automatic wire stripper, 0.2 - 6mm<sup>2</sup>
- Crimping pliers for cable lug / tab connector, 0.5 - 6mm<sup>2</sup>
- Torque wrench for 2.0 - 10 Nm
- Hose clamping pliers
- Metric thread-setter kit
- Punching tool, 60 mm dia.
- Deep-hole marker
- Webasto Thermo Test Diagnosis with current software

### Dimensions

- All dimensions are in mm.















### Tightening torque values

- Tightening torque values of 5x13 heater bolts and 5x11 heater stud bolts = 8Nm.
- Tightening torque value of 5x15 water connection piece retaining plate bolt = 7Nm.
- Tighten other bolt connections in accordance with manufacturer's instructions or in accordance with state-of-the-art-technology.

## Explanatory Notes on Document

You will find an identification mark on the outside top right corner of the page in question to provide you with a quick overview of the individual working steps.

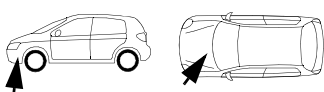
Special features are highlighted using the following symbols:

<b>Mechanical System</b>		<b>Specific risk of injury or fatal accidents.</b>	
<b>Electrical System</b>		<b>Specific risk due to electrical voltage.</b>	
<b>Coolant Circuit</b>		<b>Specific risk of damage to components.</b>	
<b>Combustion Air</b>		<b>Specific risk of fire and explosion.</b>	
<b>Fuel</b>		<b>Reference to general installation instructions of the Webasto components or to the manufacturer's vehicle-specific documents.</b>	
<b>Exhaust Gas</b>		<b>Reference to a special technical feature.</b>	
<b>Software</b>		<b>The arrow in the vehicle icon indicates the position on the vehicle and the viewing angle.</b>	
		<b>Tightening torque according to the manufacturer's vehicle-specific documents.</b>	

# Ford Focus / C-Max / Grand C-Max

## Preliminary Work

### Vehicle

- Open the fuel tank cap.
- Ventilate the fuel tank.
- Close the fuel tank cap again.
- Depressurise the cooling system.
- Disconnect and remove the battery.
- Remove the engine cover.
- Remove the windscreen wiper.
- Remove the upper cover of the coolant reservoir.
- Remove the cover of the coolant reservoir for the engine compartment.
- Drain the coolant according to the manufacturer's instructions.
- Remove the intake hose.
- Remove the engine underdrive protection.
- Remove the underbody trim on the right next to the tank.
- Detach the heat protection trim of the exhaust system in the area of the tank.
- Remove the tank.
- Remove the footwell trim on the front passenger's side.
- Remove the glove box.
- Remove the shift lever trim (only in case of automatic air-conditioning).
- Remove the centre console trim (only in case of automatic air-conditioning).
- Remove the A/C control panel according to the manufacturer's instructions (only in case of automatic air-conditioning).
- Remove the A-pillar trim of the footwell on the front passenger's side (only in case of Telestart).

### Heater

- Remove years that do not apply from the type and duplicate label.
- Attach the duplicate label (type label) visibly in the appropriate place in the engine compartment.

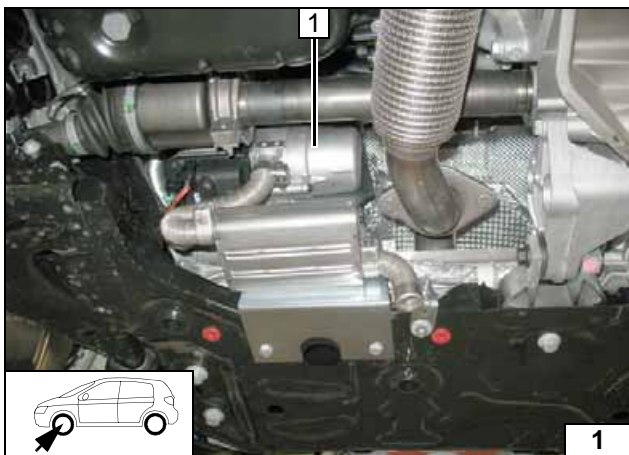

### Heater Installation Location

- 1 Heater

Installation location

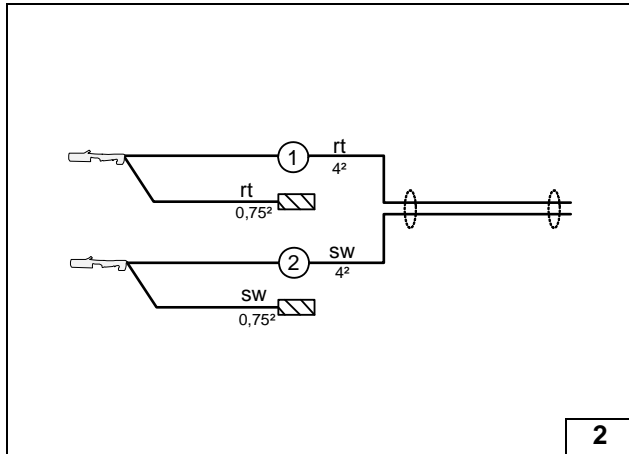

### Preparing Electrical System

Wire sections retain their numbering in the entire document.

#### Manual air-conditioning

- ① Red (rt) wire of fan wiring harness
- ② Black (sw) wire of fan wiring harness

#### Assigning wires

#### Connecting wires to passenger compartment relay and fuse holder

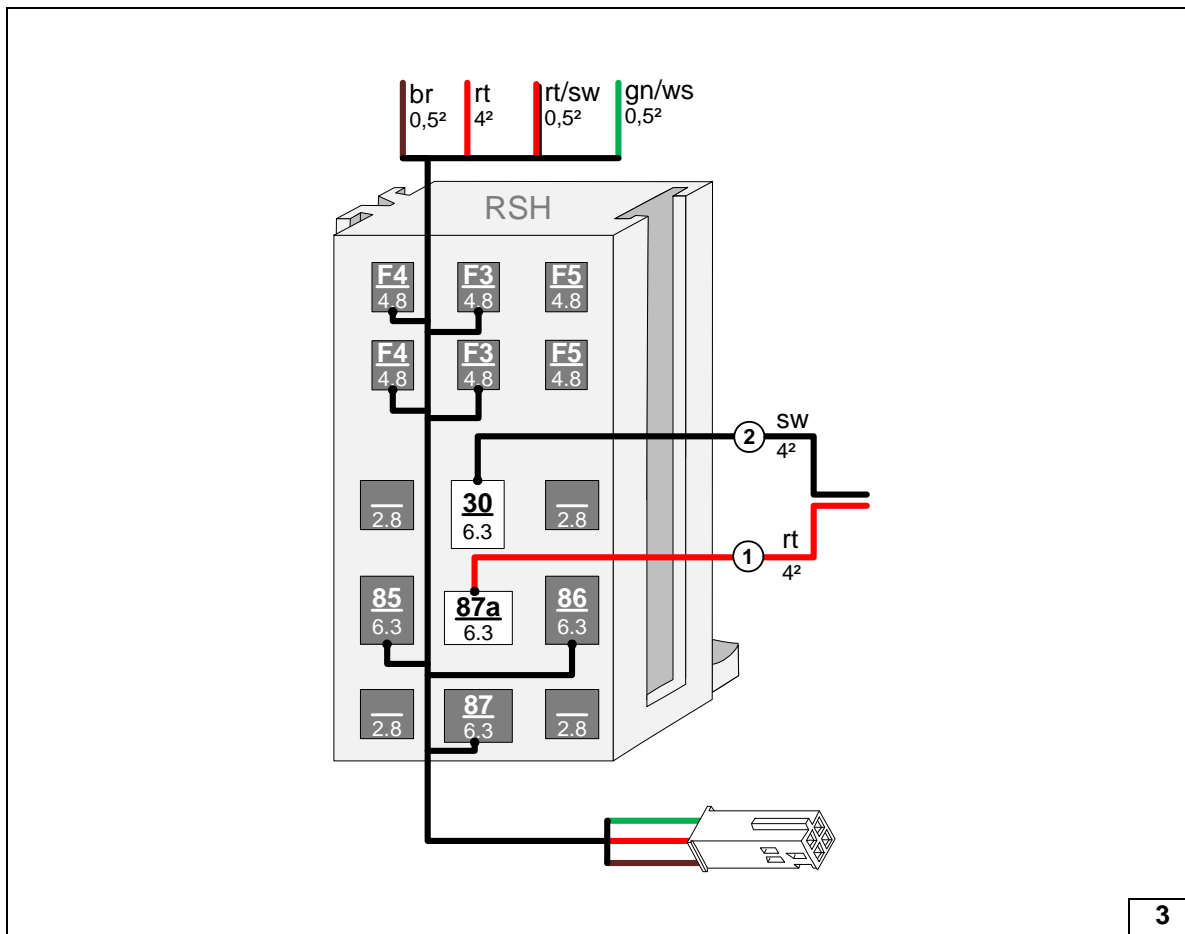

#### Dismantling metering pump connector

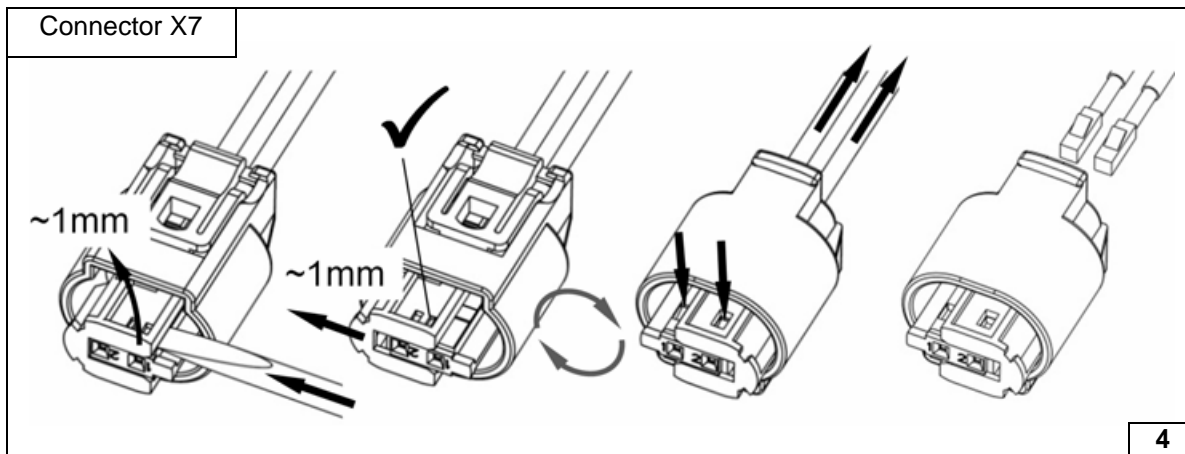

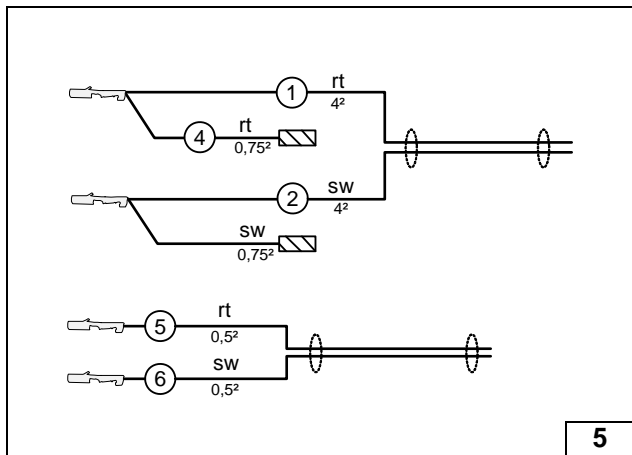

**Automatic air-conditioning**

- ① Red (rt) wire of fan wiring harness
- ② Black (sw) wire of fan wiring harness
- ⑤ Red (rt) wire from wiring harness of PWM control
- ⑥ Black (sw) wire from wiring harness of PWM control

**Preparing / assigning wiring harnesses**

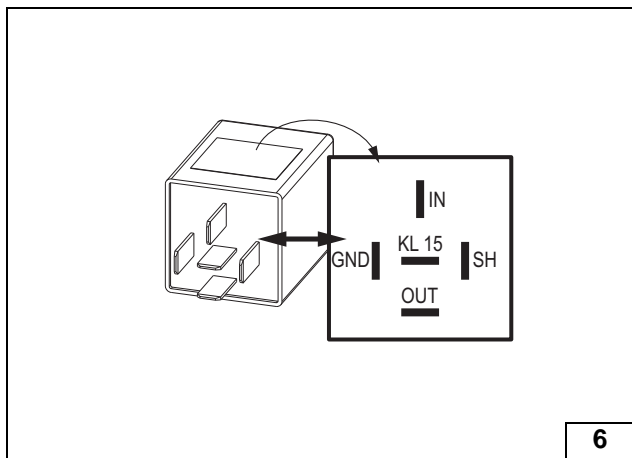

Check the PWM Gateway settings when starting up the heater and adjust if necessary.

Settings:

- Duty cycle: 37%
- Frequency: 400Hz
- Voltage: not relevant
- Function: Low side

**View of PWM GW**

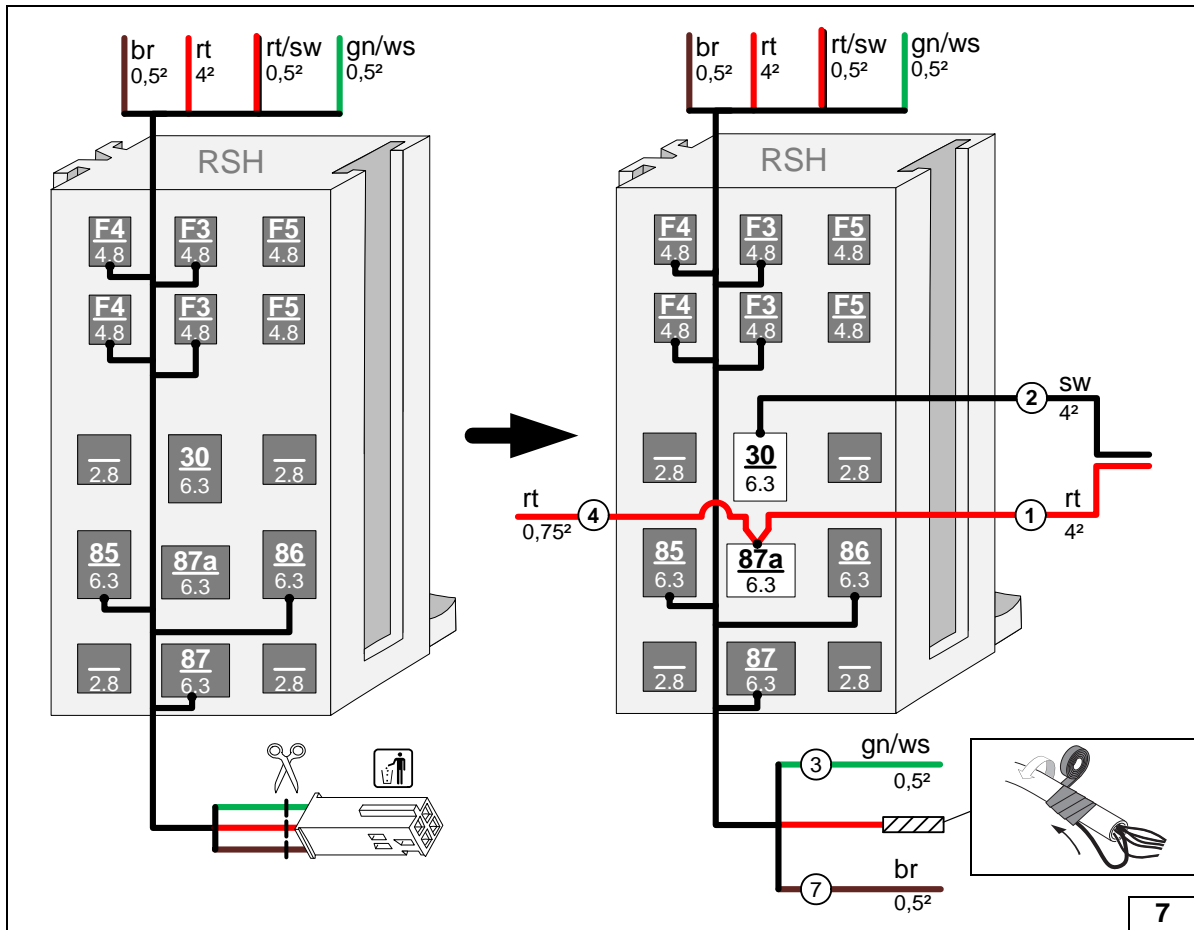

**Preparing passenger compartment relay and fuse holder / connecting / assigning wires**

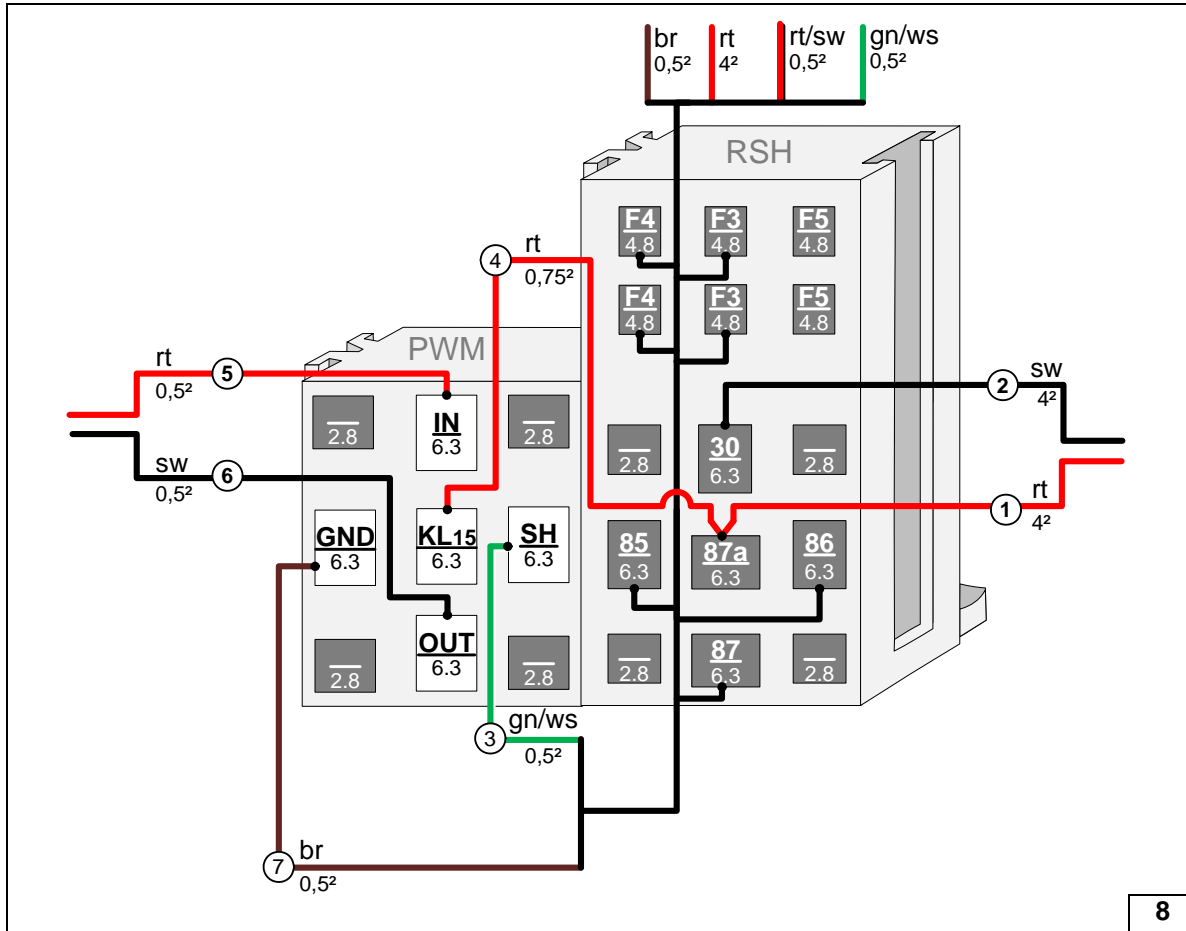

Interlocking PWM GW socket and passenger compartment relay and fuse holder, connecting wires





## Electrical System

### Wiring Harness Routing for Focus

#### Positive and earth wire

- 1 Earth wire, 8 mm dia. cable lug at original vehicle earth support point
- 2 Positive wire on positive battery terminal

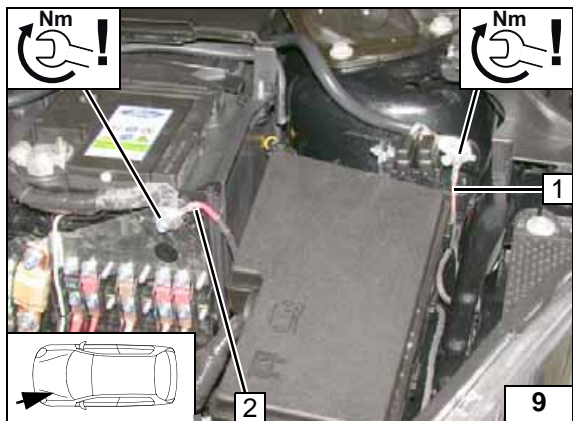

#### Wiring harness pass through

- 1 Protective rubber plug

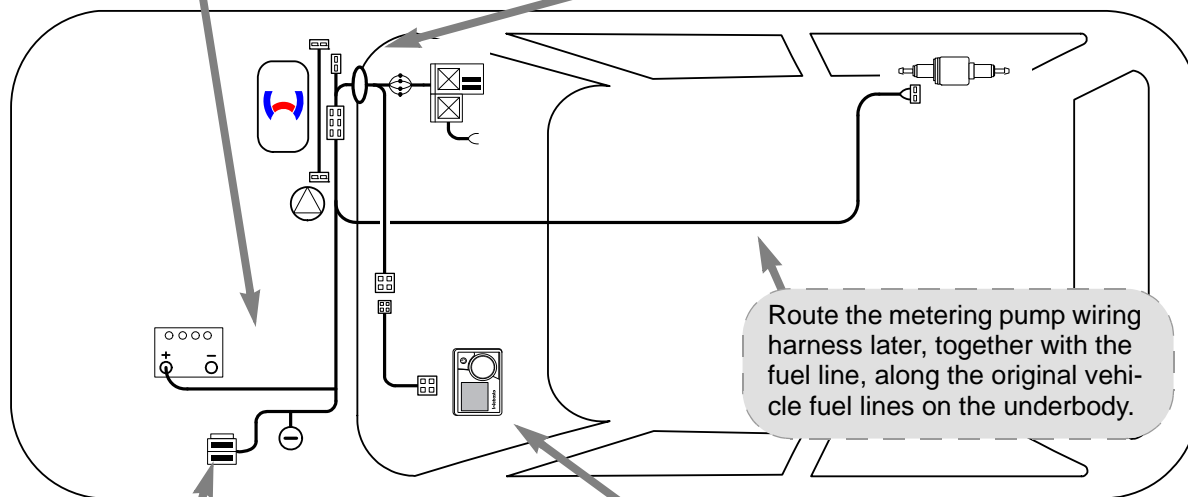
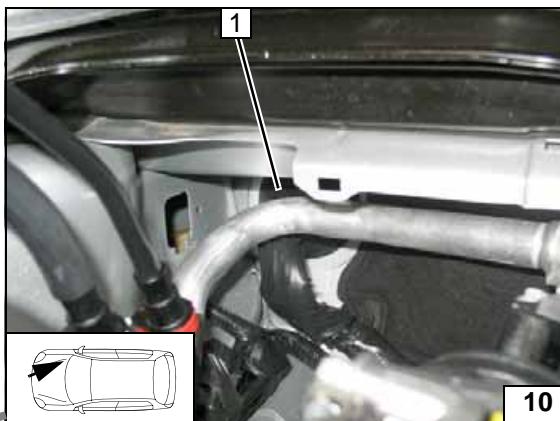

Wiring harness routing diagram

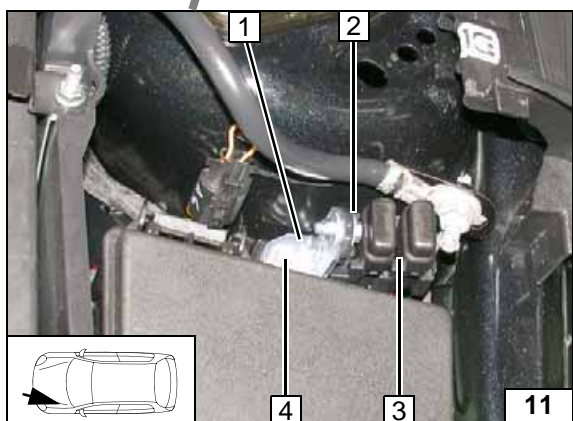

#### Engine compartment fuse holder

- 1 Angle bracket
- 2 M5x16 bolt, large diameter washer [2x], retaining plate of fuse holder, nut
- 3 Fuses F1-2
- 4 M6x20 bolt, flanged nut, existing hole

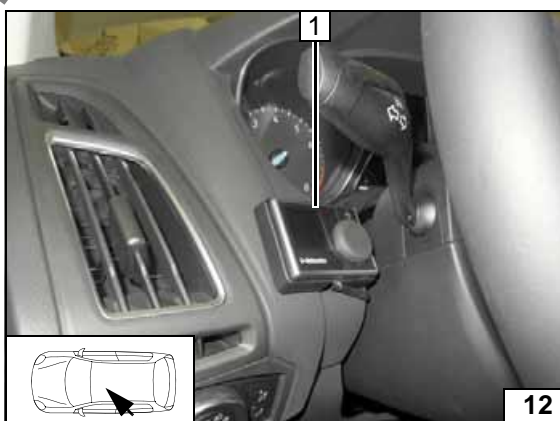

#### MultiControl CAR Focus Option

Use timer cable extension when installing MultiControl CAR.

- 1 MultiControl CAR



### Wiring Harness Routing for C-Max / Grand C-Max

#### Positive and earth wire

- 1 Earth wire, 8 mm dia. cable lug at original vehicle earth support point
- 2 Positive wire on positive battery terminal

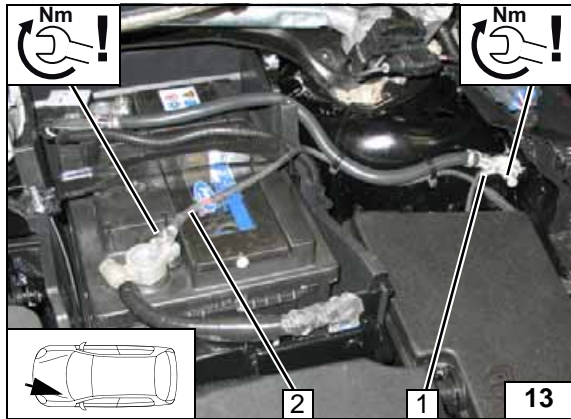

#### Wiring harness pass through

- 1 Protective rubber plug

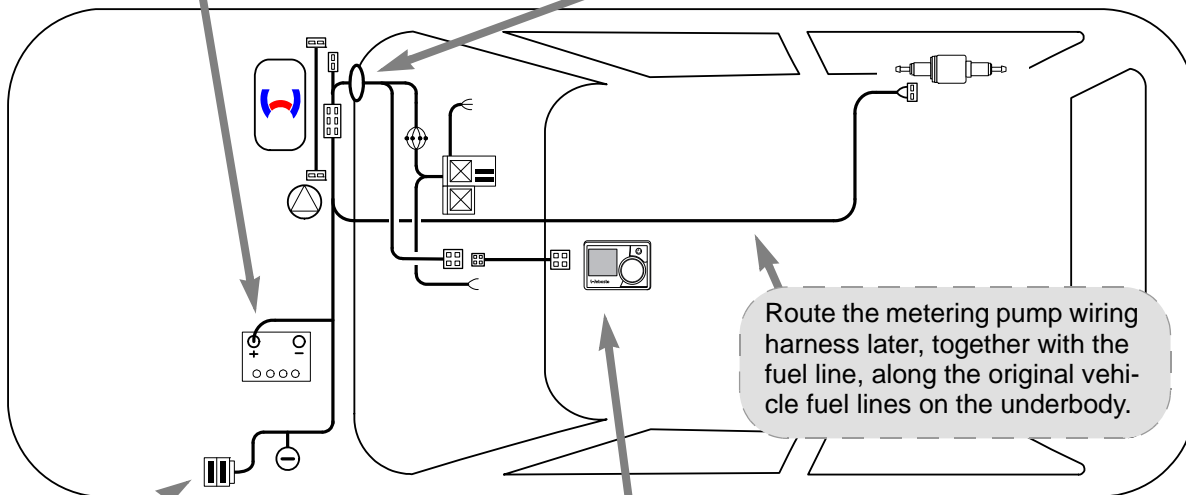
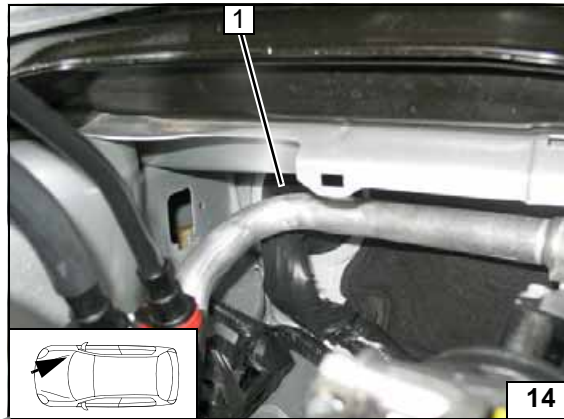

Wiring harness routing diagram

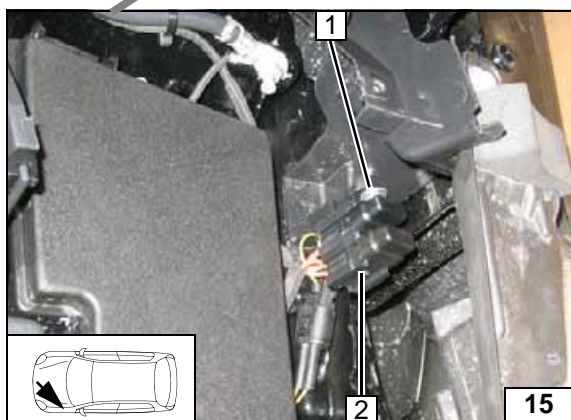

#### Engine compartment fuse holder

When drilling, be careful of components located behind!

- 1 5.5mm dia. hole, M5x16 bolt, large diameter washer, retaining plate of fuse holder, nut
- 2 Fuses F1-2

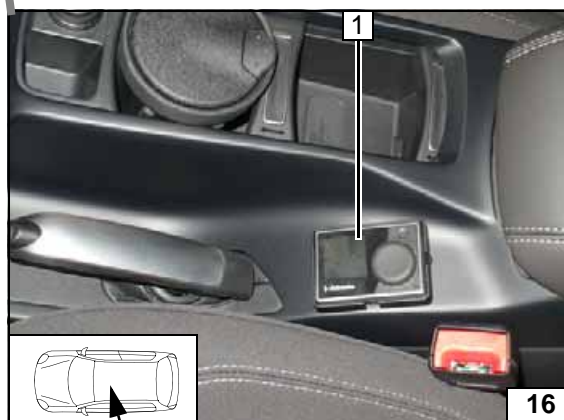

#### MultiControl CAR C-Max / Grand C-Max Option

Use timer cable extension when installing MultiControl CAR.

- 1 MultiControl CAR



Wiring Diagram for Manual Air-Conditioning

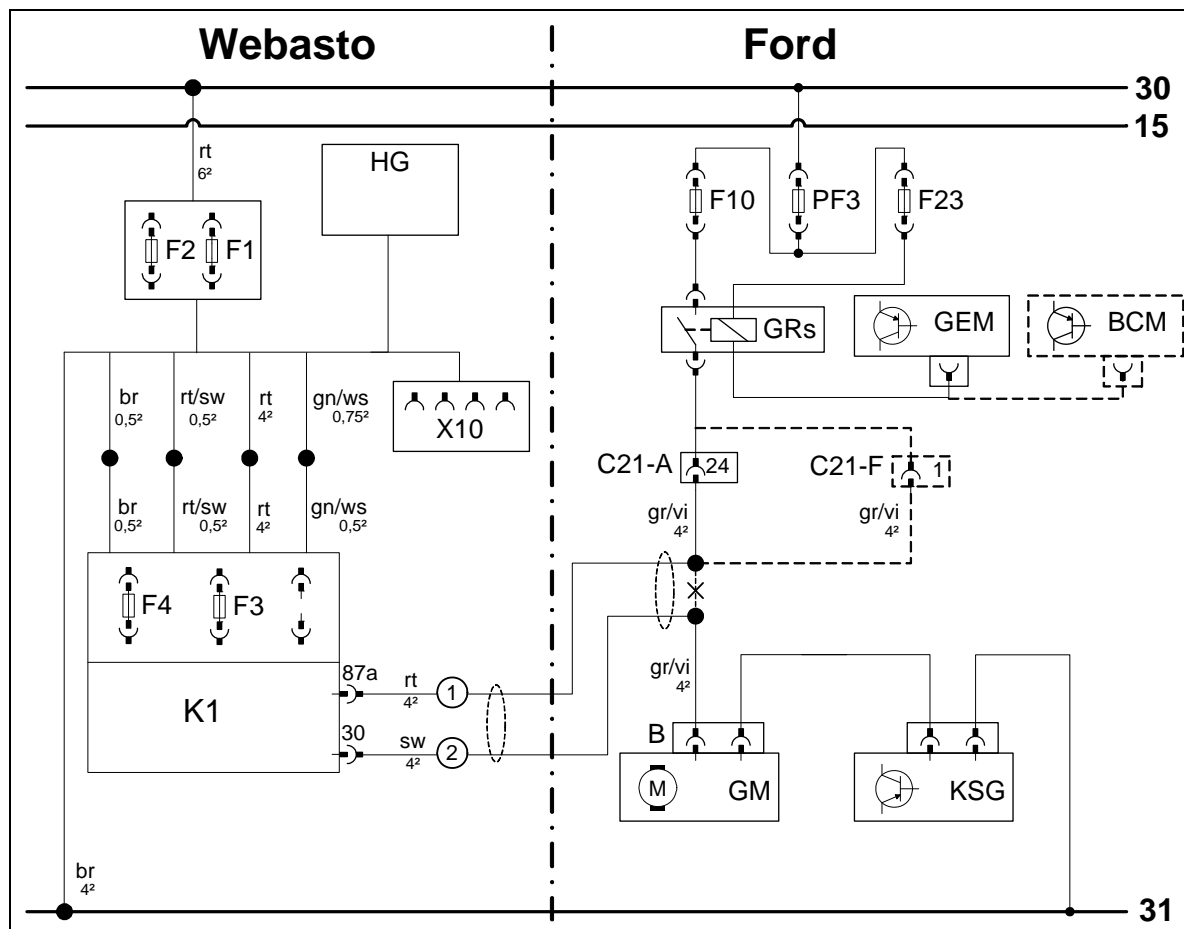

System wiring diagram

Webasto components		Vehicle components		Colours and symbols	
HG	TT-Evo heater	F10	40A fuse	rt	red
F1	20A fuse	PF3	100A fuse	sw	black
F2	30A fuse	F23	5A fuse	gn	green
X10	4-pin connector of heater control	BCM	Body control unit (Focus)	ws	white
F3	1A fuse	GEM	Central electrical box module (C-Max / Grand C-Max)	br	brown
F4	25A fuse	GRs	Fan relay	gr	grey
K1	Fan relay	C21-F	Connector (Focus)	vi	violet
		C21-A	Connector (C-Max / Grand C-Max)		
		KSG	A/C control unit		
		GM	Fan motor	X	Cutting point
		B	Fan motor connector	Wiring colours may vary.	

Legend



## Manual Air-Conditioning Fan Controller

Produce all following electrical connections as shown in the wiring diagram.

### Focus

- 1 6.5 mm dia. hole

Hole for passenger compartment relay and fuse holder

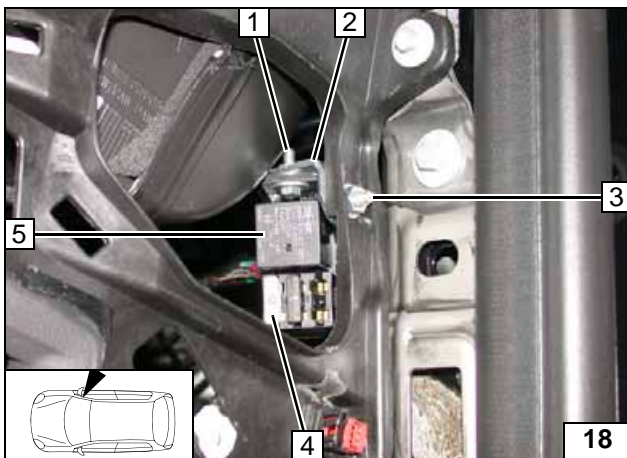
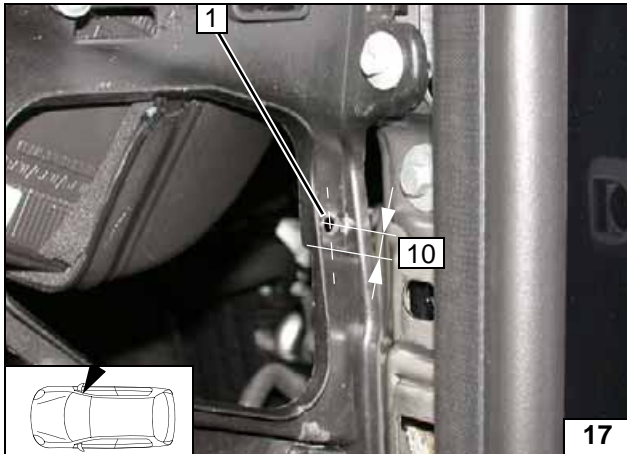

- 1 M5x16 bolt, large diameter washer, passenger compartment relay and fuse holder, large diameter washer, nut
- 2 Angle bracket
- 3 M6x20 bolt, flanged nut
- 4 25A fuse F4
- 5 Relay K1

Installing passenger compartment relay and fuse holder

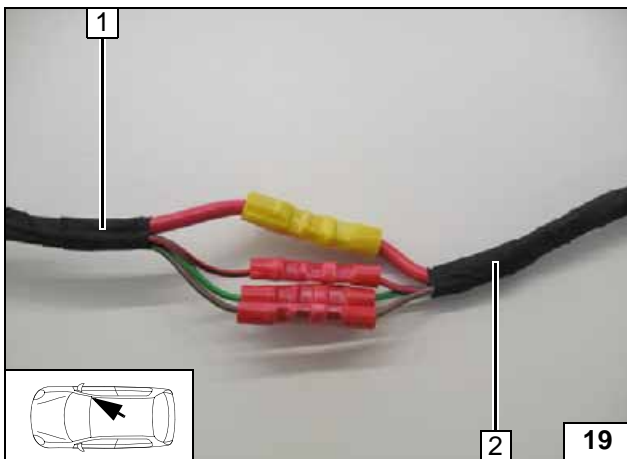

- 1 Passenger compartment relay and fuse holder wiring harness
- 2 Heater wiring harness

Connecting same colour wires of wiring harnesses

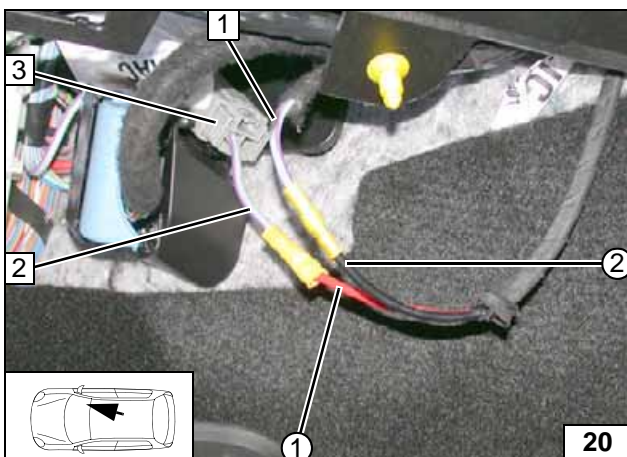

- 1 Grey/violet (gr/vi) wire of fan motor
- 2 Grey/violet (gr/vi) wire of connector C21-F / pin 1
- 3 Connector C21-F
- ① Red (rt) wire of K1/87a, fan wiring harness
- ② Black (sw) wire of K1/30, fan wiring harness

Connecting fan motor

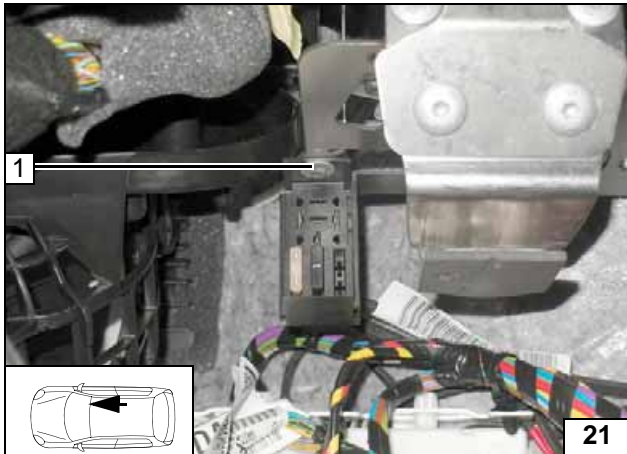

**C-Max / Grand C-Max**

- 1 M5x16 bolt, large diameter washer, passenger compartment relay and fuse holder tab, original vehicle hole, large diameter washer, nut

**Installing passenger compartment relay and fuse holder**

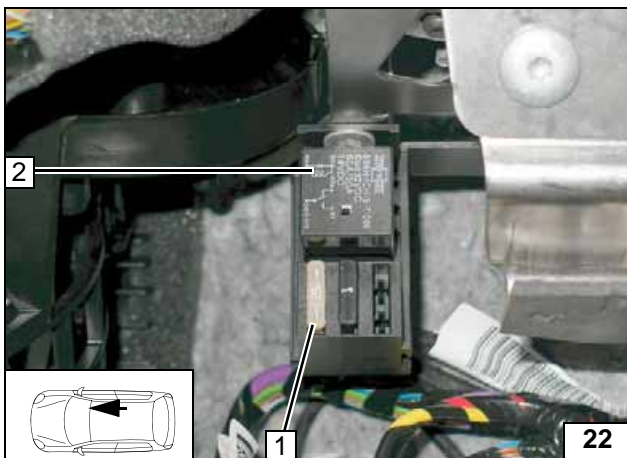

- 1 25A fuse F4
- 2 Relay K1

**Inserting fuse F4 and relay K1**

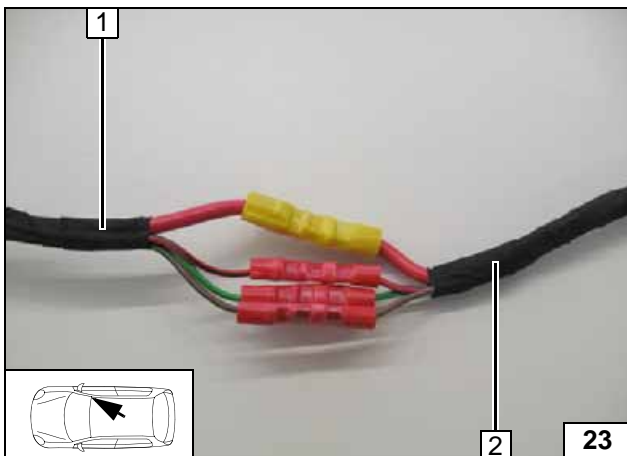

- 1 Passenger compartment relay and fuse holder wiring harness
- 2 Heater wiring harness

**Connecting same colour wires of wiring harnesses**

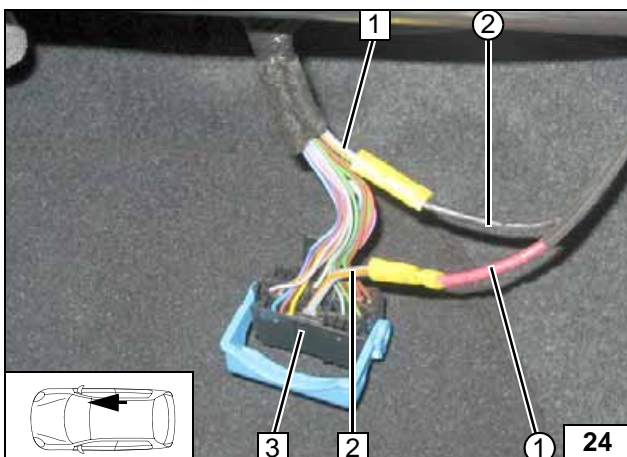

- 1 Grey/violet (gr/vi) wire of fan motor
- 2 Grey/violet (gr/vi) wire of connector C21-A / pin 24
- 3 Connector C21-A
- ① Red (rt) wire of K1/87a, fan wiring harness
- ② Black (sw) wire of K1/30, fan wiring harness

**Connecting fan motor**



Automatic Air-Conditioning Wiring Diagram

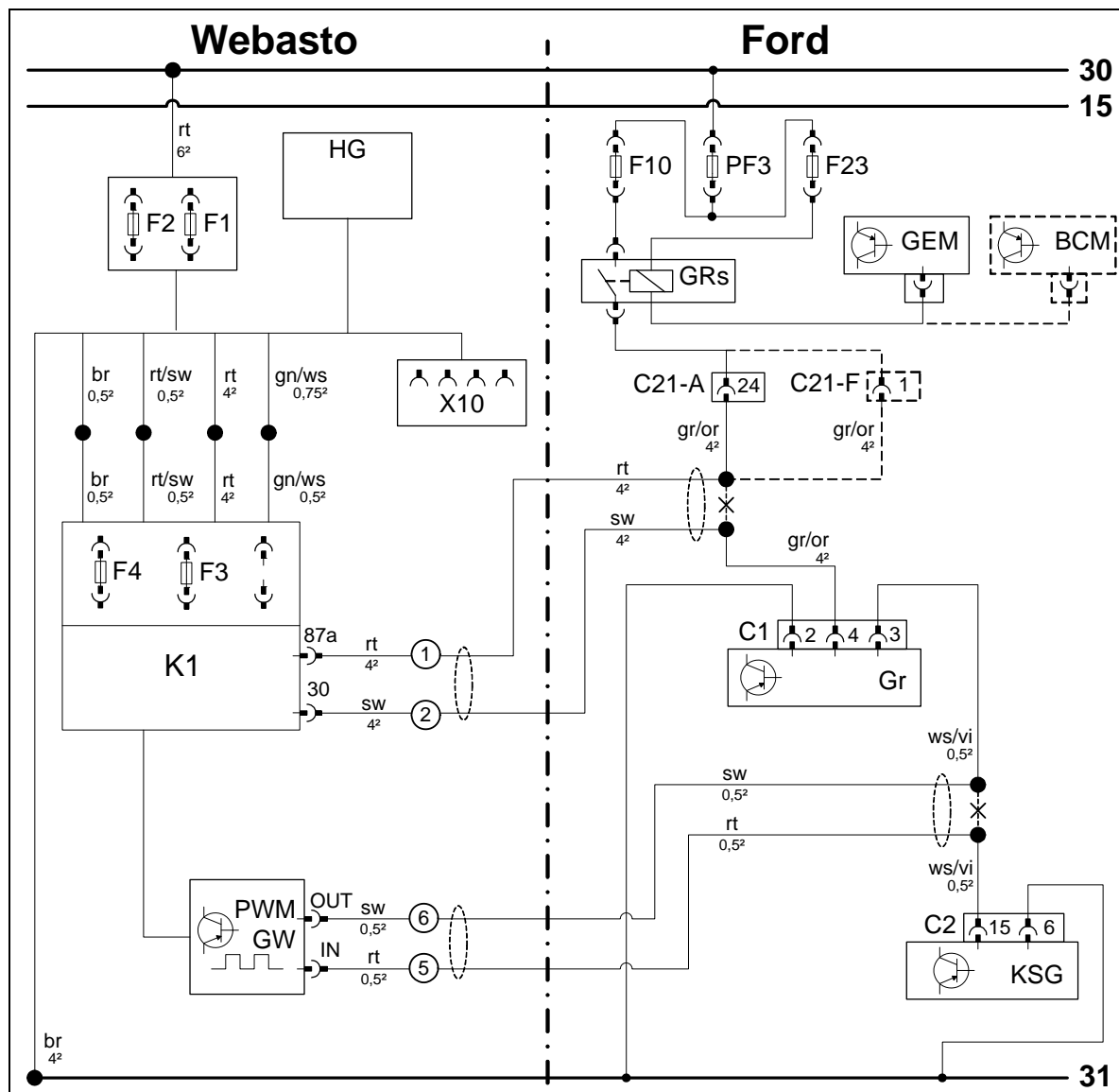

System wiring diagram

Webasto components		Vehicle components		Colours and symbols	
HG	TT-Evo heater	F23	5A fuse	rt	red
F1	20A fuse	F10	40A fuse	sw	black
F2	30A fuse	PF3	100A fuse	gn	green
X10	4-pin connector of heater control	GEM	Central electrical box module (C-Max / Grand C-Max)	br	brown
F3	1A fuse	BCM	Body control unit (Focus)	ws	white
F4	25A fuse			gr	grey
K1	Fan relay	GRs	Fan relay	vi	violet
PWM GW	Pulse width modulator	C21-A	Connector (C-Max / Grand C-Max)	or	orange
<b>PWM GW settings:</b>		C21-F	Connector (Focus)		
Duty cycle: 37%		Gr	Fan controller		
Frequency: 400Hz		C1	Fan controller connector		
Voltage: not relevant		KSG	A/C control unit	X	Cutting point
Function: Low side		C2	Connector of KSG	Wiring colours may vary.	

Legend

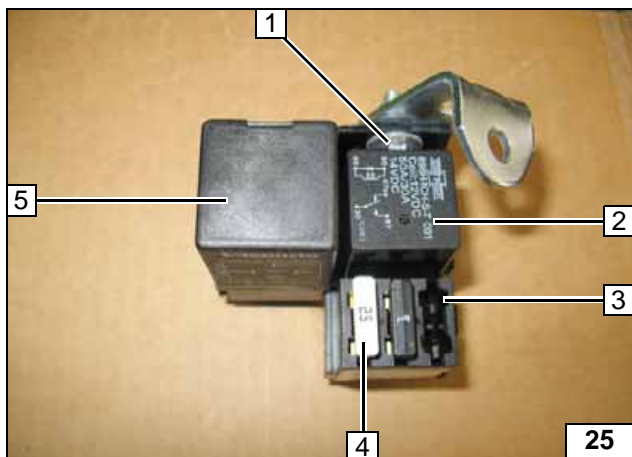

### Automatic Air-Conditioning Fan Controller

Produce all following electrical connections as shown in the wiring diagram.

#### Focus

- 1 M5x16 bolt, large diameter washer, passenger compartment relay and fuse holder, angle bracket, large diameter washer, nut
- 2 Relay K1
- 3 Passenger compartment relay and fuse holder
- 4 25A fuse F4
- 5 PWM GW

**Premounting passenger compartment relay and fuse holder**

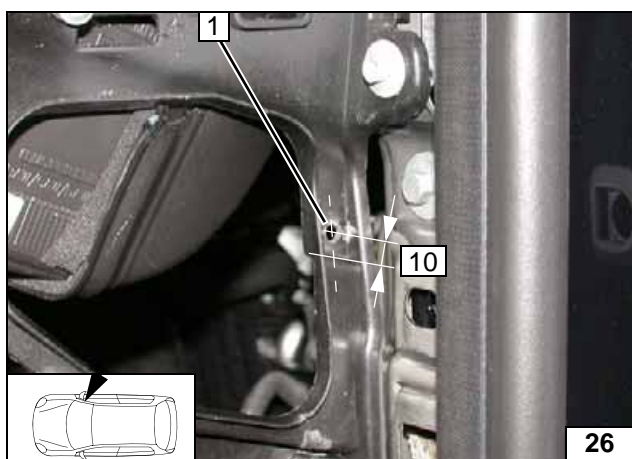

- 1 6.5 mm dia. hole

**Hole for passenger compartment relay and fuse holder**

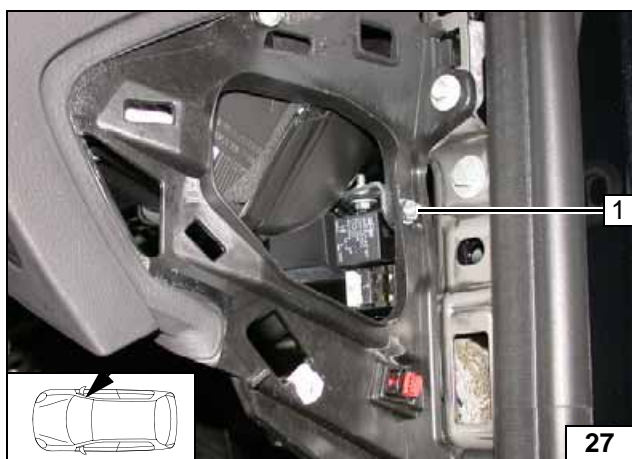

- 1 M6x20 bolt, premounted angle bracket, flanged nut

**Installing passenger compartment relay and fuse holder**

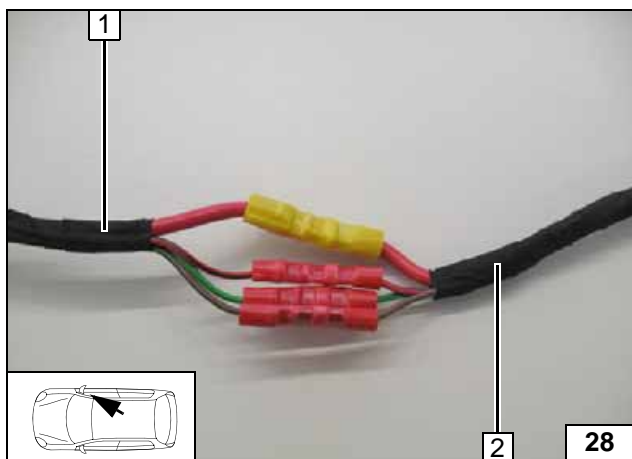

- 1 Passenger compartment relay and fuse holder wiring harness
- 2 Heater wiring harness

**Connecting same colour wires of wiring harnesses**

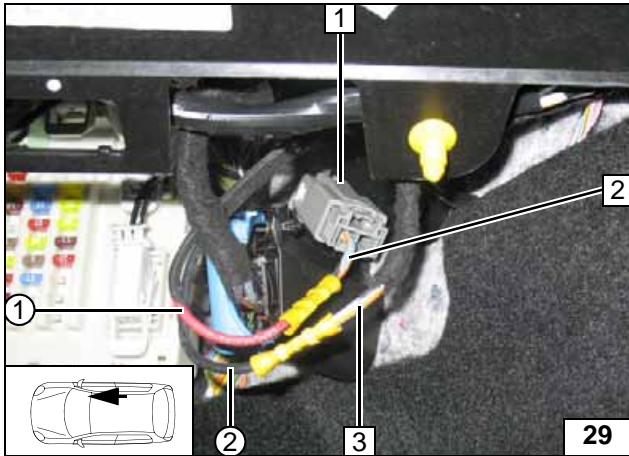

- 1 Connector C21-F
- 2 Grey/orange (gr/or) wire of connector C21-F/ pin 1
- 3 Grey/orange (gr/or) wire from connector C1 / pin 4 of fan controller
- ① Red (rt) wire of K1/87a, fan wiring harness
- ② Black (sw) wire of K1/30, fan wiring harness

**Connect-  
ing fan con-  
troller**

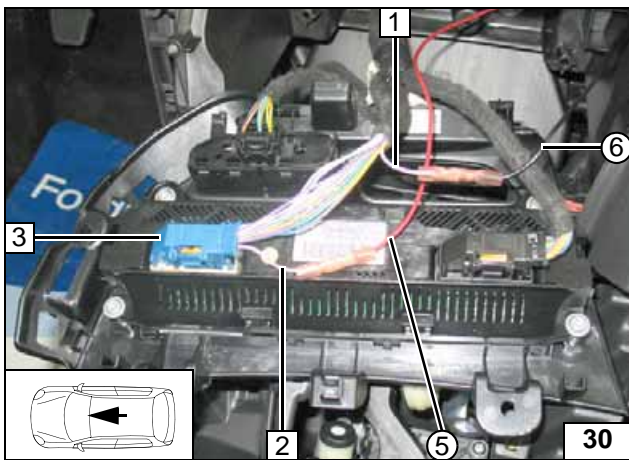

- 1 White/violet (ws/vi) wire from connector C1/ pin 3 of fan controller
- 2 White/violet (ws/vi) wire from connector C2/ pin 15 of A/C control unit
- 3 Connector C2 of A/C control unit
- ⑤ Red (rt) wire from PWM GW/ IN of PWM control wiring harness
- ⑥ Black (sw) wire from PWM GW/ OUT of PWM control wiring harness

**Connect-  
ing A/C  
control unit**

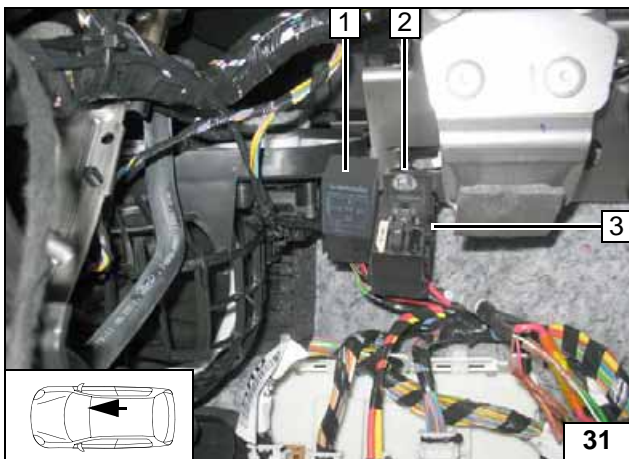

**C-Max / Grand C-Max**

- 1 PWM GW
- 2 M5x16 bolt, large diameter washer, existing threaded hole
- 3 Passenger compartment relay and fuse holder

**Installing  
passenger  
compartment  
relay and fuse  
holder**

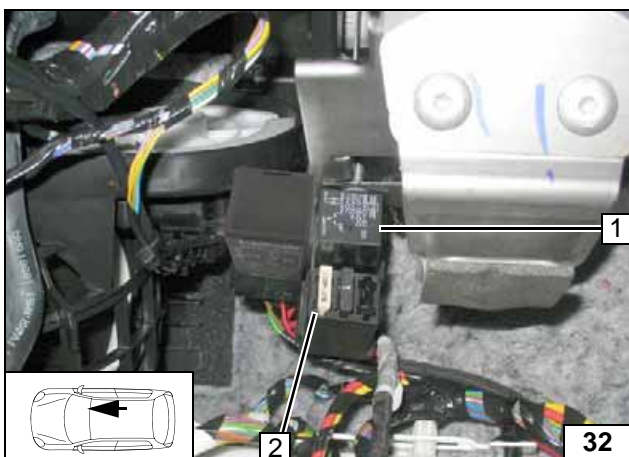

- 1 Relay K1
- 2 25A fuse F4

**Installing re-  
lay K1 and  
fuse F4**



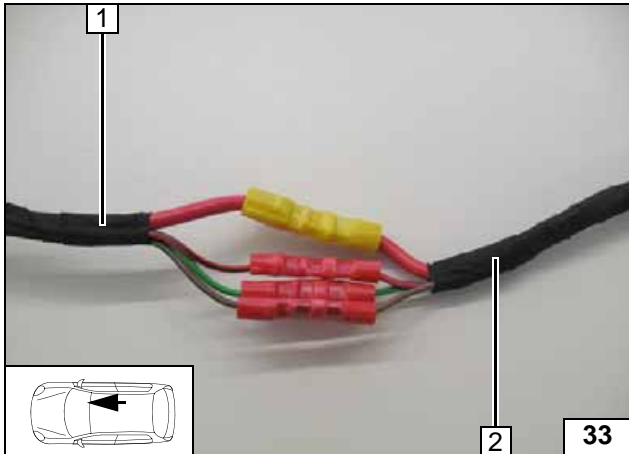

- 1 Passenger compartment relay and fuse holder wiring harness
- 2 Heater wiring harness

Connecting same colour wires of wiring harnesses

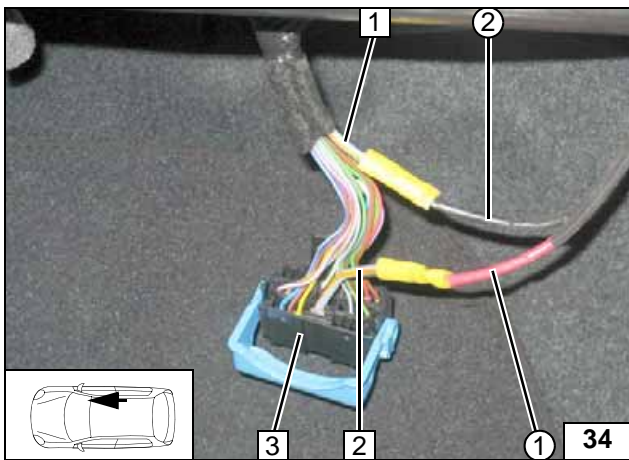

- 1 Grey/orange (gr/or) wire from connector C1 / pin 4 of fan controller
- 2 Grey/orange (gr/or) wire of connector C21-A/ pin 24
- 3 Connector C21-A
- ① Red (rt) wire of K1/87a, fan wiring harness
- ② Black (sw) wire of K1/30, fan wiring harness

Connecting fan controller

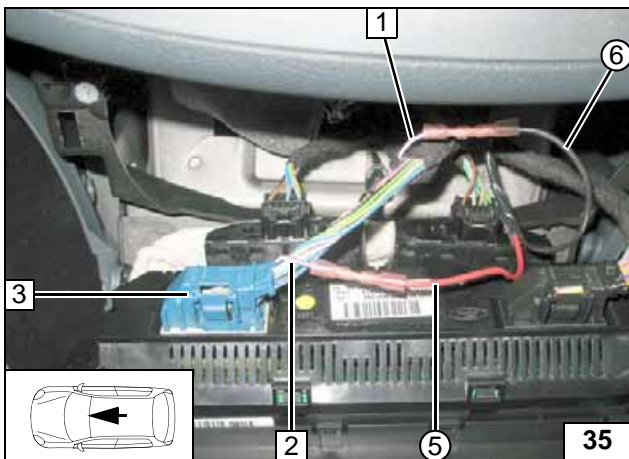

- 1 White/violet (ws/vi) wire from connector C1/ pin 3 of fan controller
- 2 White/violet (ws/vi) wire from connector C2/ pin 15 of A/C control unit
- 3 Connector C2 of A/C control unit
- ⑤ Red (rt) wire from PWM GW/ IN of PWM control wiring harness
- ⑥ Black (sw) wire from PWM GW/ OUT of PWM control wiring harness

Connecting A/C control unit

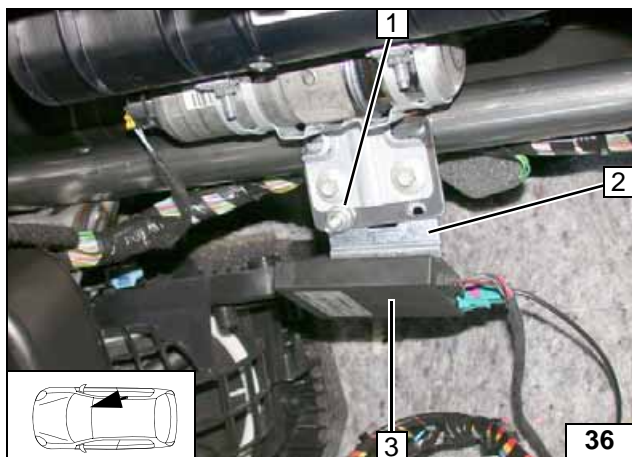

### Telestart Focus Option

Angle down receiver bracket 2 as shown and drill out oblong mounting hole to 6.5mm.

- 1 M6x20 bolt, flanged nut, existing hole
- 3 Receiver



Installing receiver

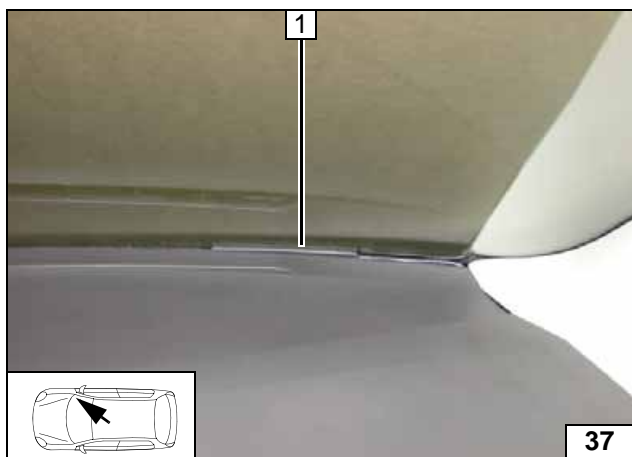

- 1 Aerial

Installing aerial

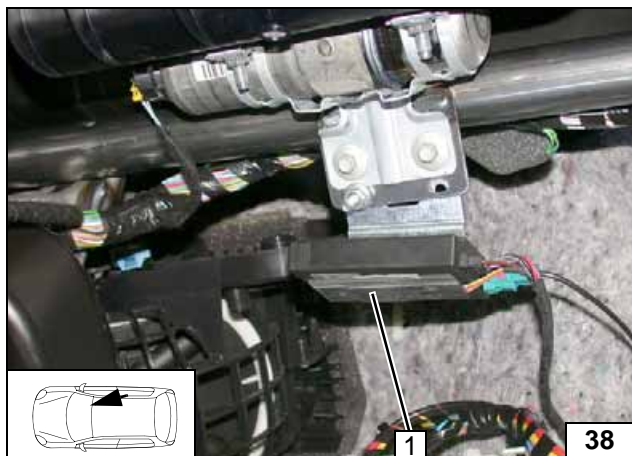

### Temperature sensor T100 HTM

Fasten temperature sensor 1 with double-sided adhesive tape.



Installing temperature sensor

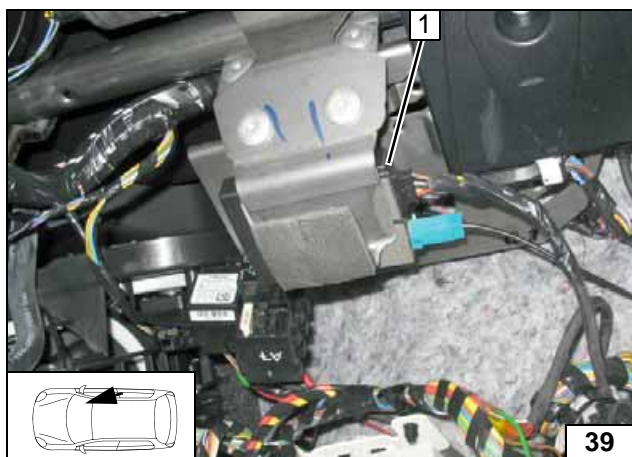

### Telestart C-Max / Grand C-Max Option

Fasten receiver 1 with double-sided adhesive tape.



Installing receiver

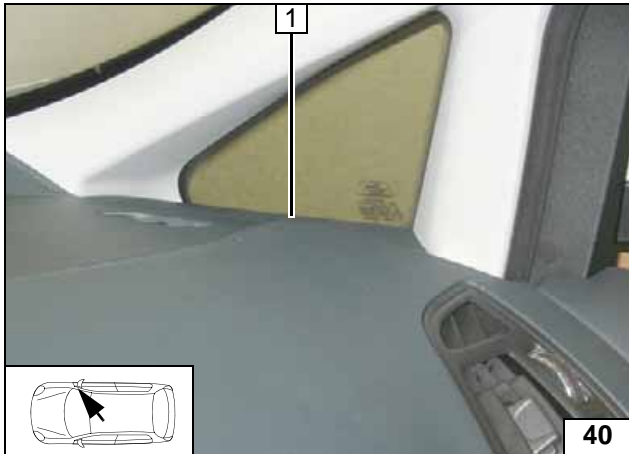
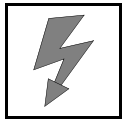

1 Aerial

Installing  
aerial

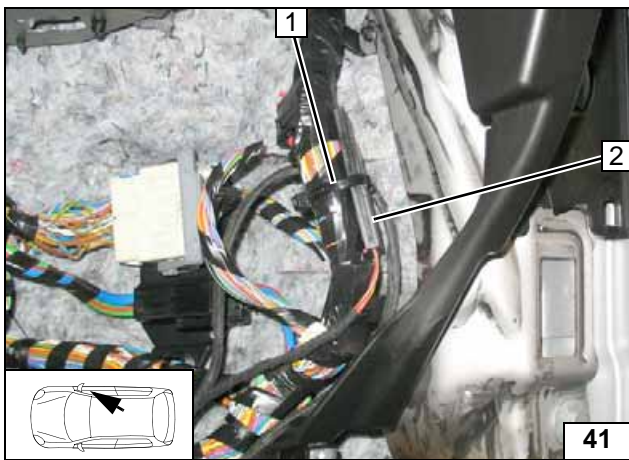

**Temperature sensor T100 HTM**

Fasten temperature sensor 2 with cable tie 1 to original vehicle wiring harness.



Installing  
tempera-  
ture sensor

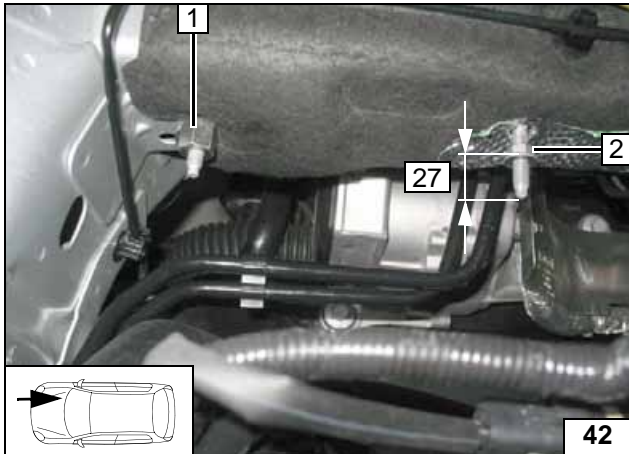

### Preparing Installation Location

Mount M8 flanged nut 2 on original vehicle stud bolt with flange in front (screw it approx. 27mm)!

- 1 M8x20 spacer nut, original vehicle stud bolt



Preparing installation location

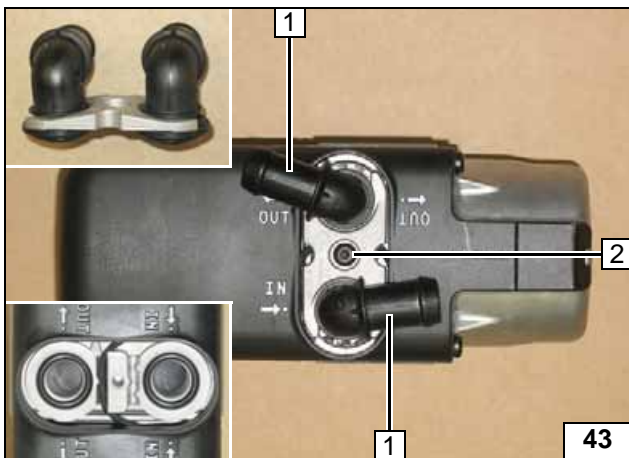

### Preparing Heater

- 1 Water connection piece, sealing ring [2x each]
- 2 5x15 self-tapping bolt, retaining plate of water connection piece



Installing water connection piece

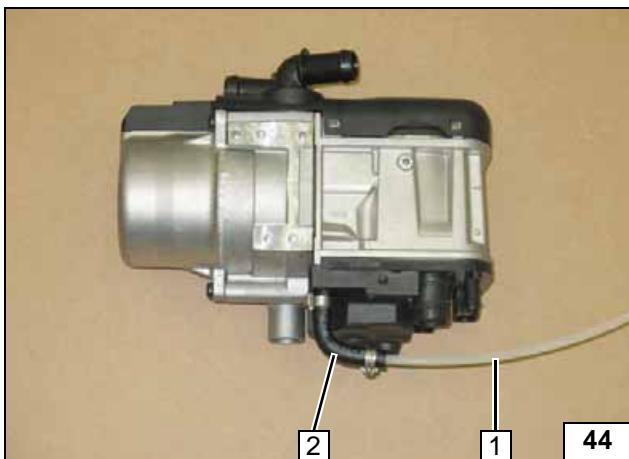

- 1 Fuel line
- 2 90° moulded hose, 10 mm dia. clamp [2x]

Premounting fuel line

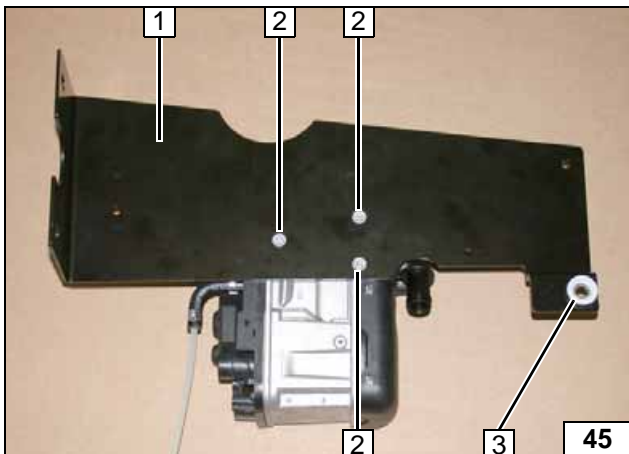

- 1 Bracket
- 2 5x13 self-tapping bolt [3x]
- 3 Rubber buffer, insert sleeve

Installing bracket

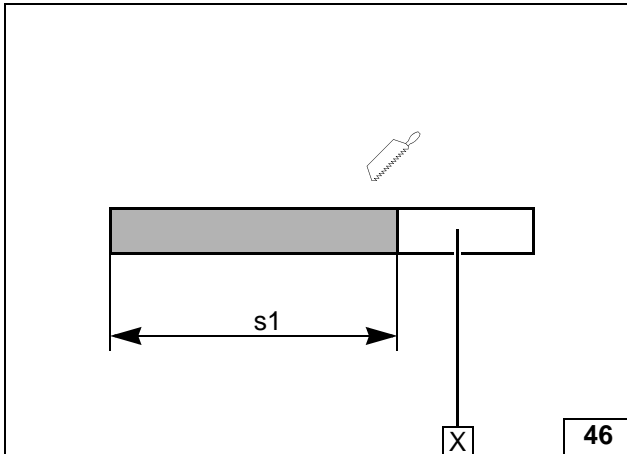

s1 = 600

X =

Cutting combustion air pipe to length



Installing combustion air pipe s1

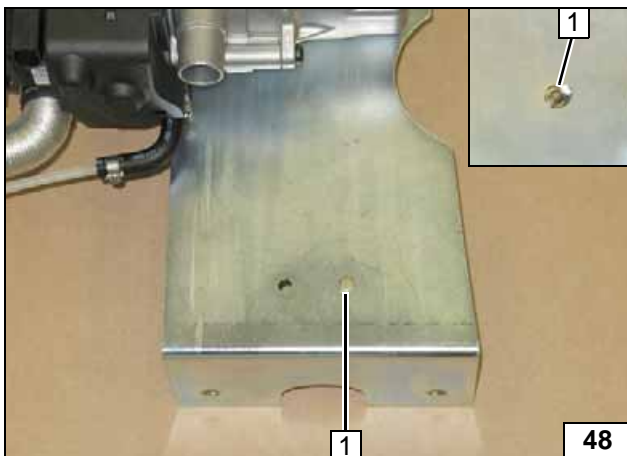

1 M4x12 bolt, nut

Mounting twist lock

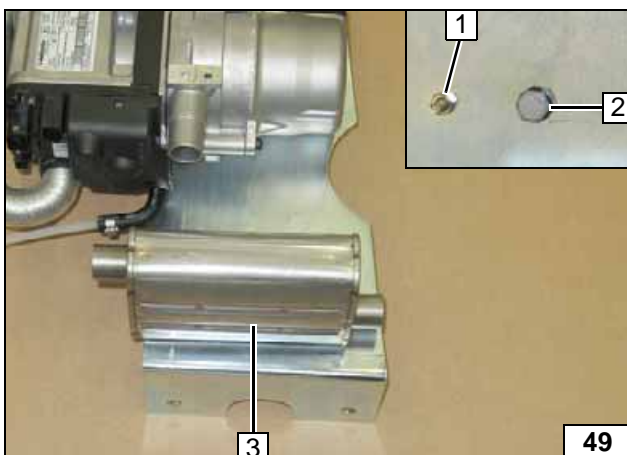

Position housing notch of silencer 3 over bolt head 1 (twist lock).

2 M6x16 bolt, spring lockwasher

Installing silencer



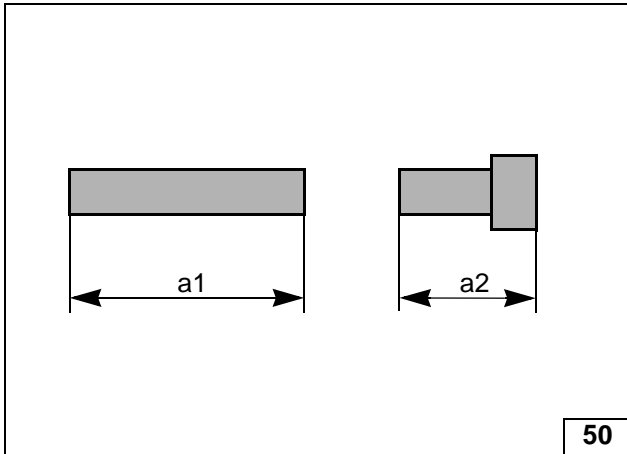

a1 = 200  
a2 = 93

Assigning  
exhaust  
pipe

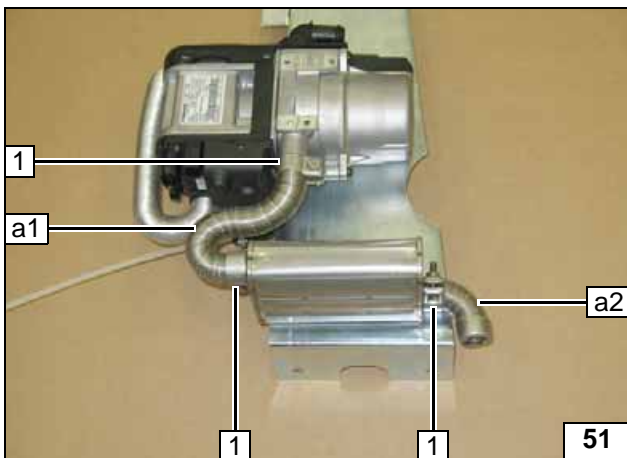

1 Hose clamp [3x]

Installing  
exhaust  
pipe

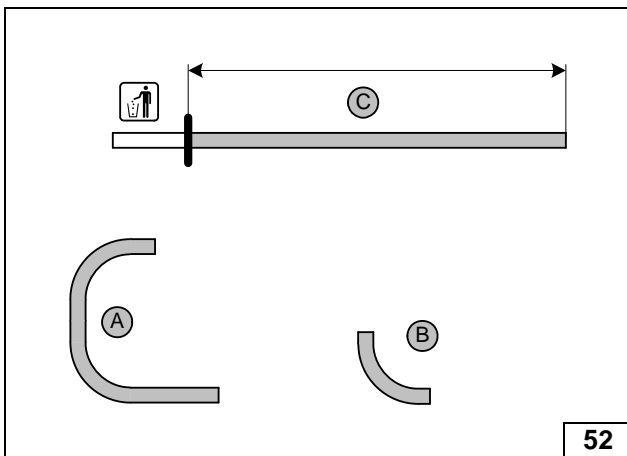

Hose A= 180°, 18 mm dia. moulded hose  
Hose B= 90°, 18 mm dia. moulded hose

C = 460



Cutting  
hose to  
length

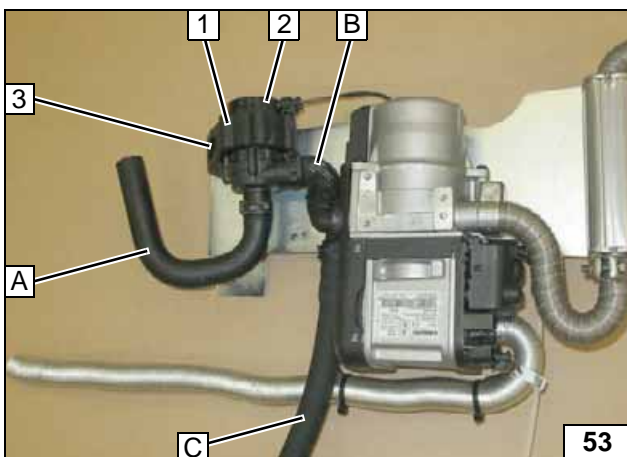

All spring clips = 25 mm dia.

- 1 Circulating pump mount
- 2 Circulating pump
- 3 M6x25 bolt, flanged nut



Mounting  
hoses and  
circulating  
pump

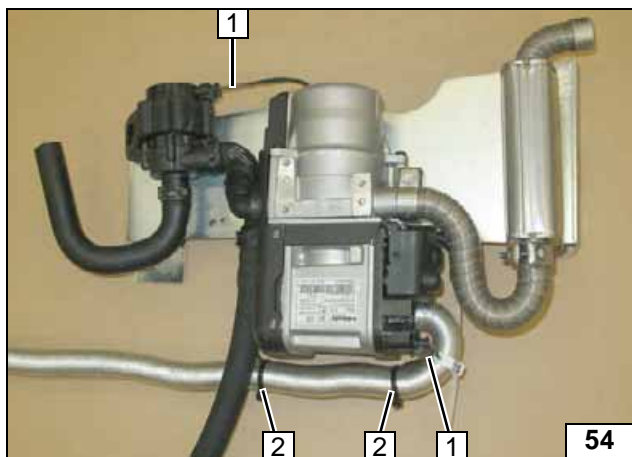

- 1 Circulating pump wiring harness
- 2 Cable tie [2x]

Installing wiring harness

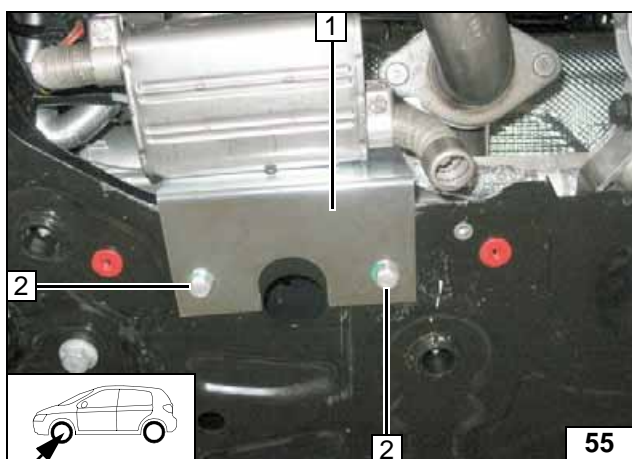

### Installing Heater

- 1 Bracket
- 2 Install bolt M8x20, washer, flanged nut, existing hole [2x each] loosely

Loosely mounting heater

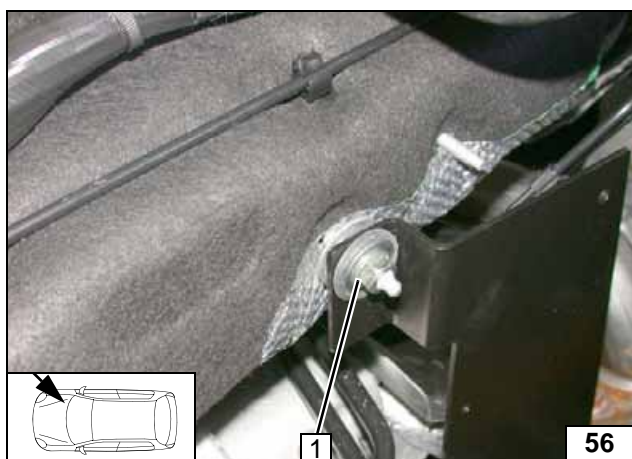

Mount heater on original vehicle stud bolt. Install large diameter washer, M8 flanged nut 1.



Installing heater



Align heater. Ensure sufficient distance from neighbouring components. Ensure minimum distance > 5mm from steering components and > 15mm from parts of transmission, cardan shaft and engine. Tighten M8x20 bolts.



Aligning heater



## Coolant Circuit



### WARNING!

Any coolant running off should be collected in an appropriate container. Route hoses kink-free. Unless specified otherwise, always fasten using cable ties. Position clamps so that other hoses cannot be damaged. The heater must be filled with coolant when installing the hoses.

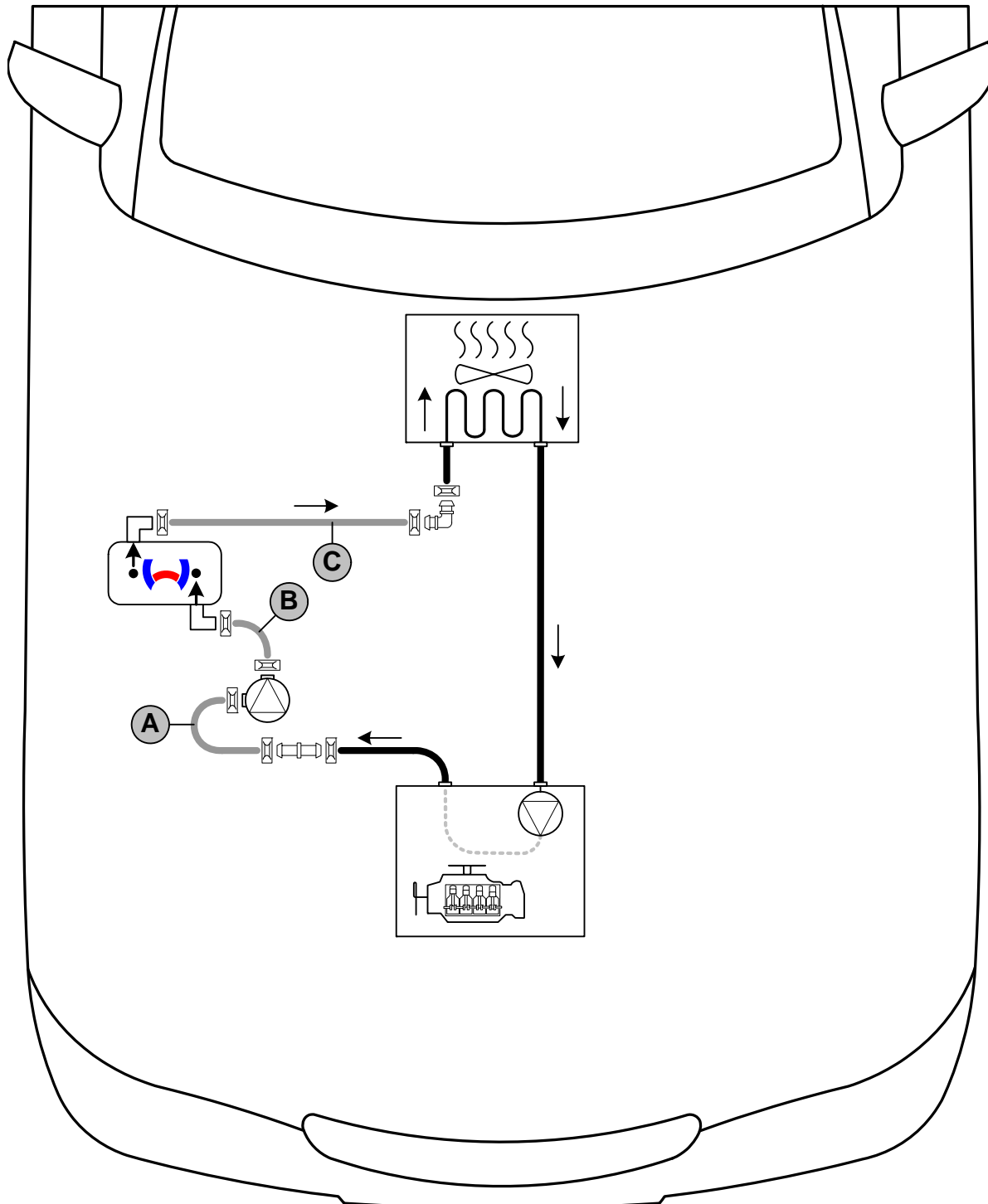
The connection should be modelled on an 'inline' circuit and based on the following diagram:  
The displayed coolant circuit is meant primarily for passenger compartment heating.



Hose routing diagram

All spring clips =  25 mm dia.  
All connecting pipes  and  = 18x18mm dia.





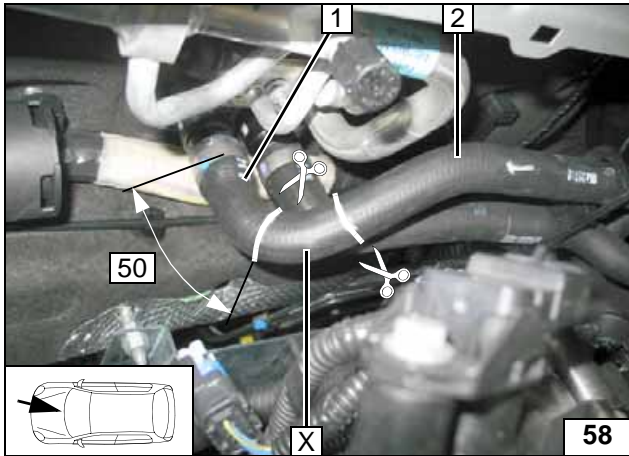

Cut hose of engine outlet / heat exchanger inlet at the markings.



- 1 Heat exchanger inlet hose section
- 2 Engine outlet hose section

X =

**Cutting point**

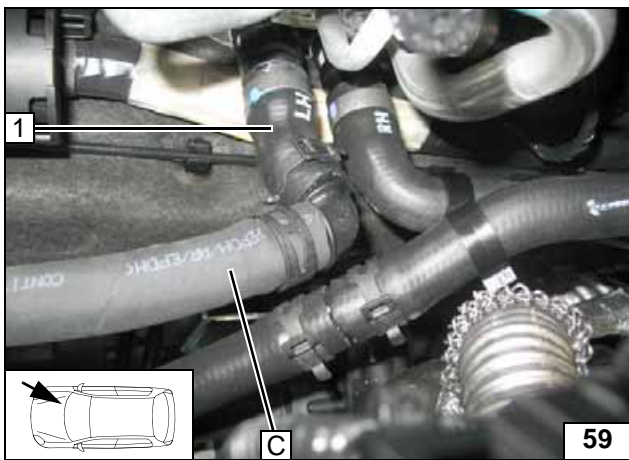

- 1 Heat exchanger inlet hose section

**Connecting heat exchanger inlet**

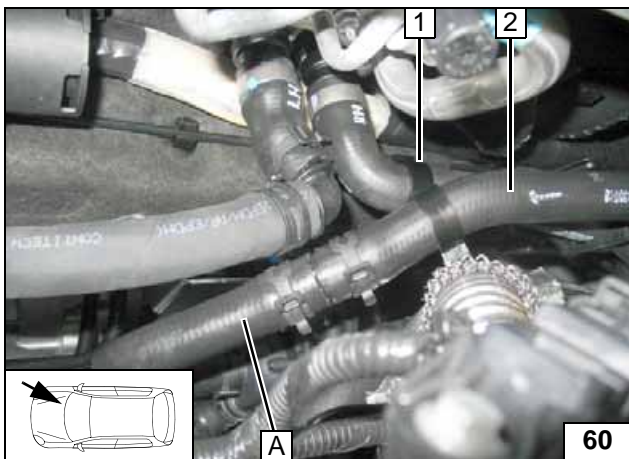

Align hoses. Ensure sufficient distance from neighbouring components, correct if necessary.



- 1 Hose bracket
- 2 Engine outlet hose section

**Connecting engine outlet**

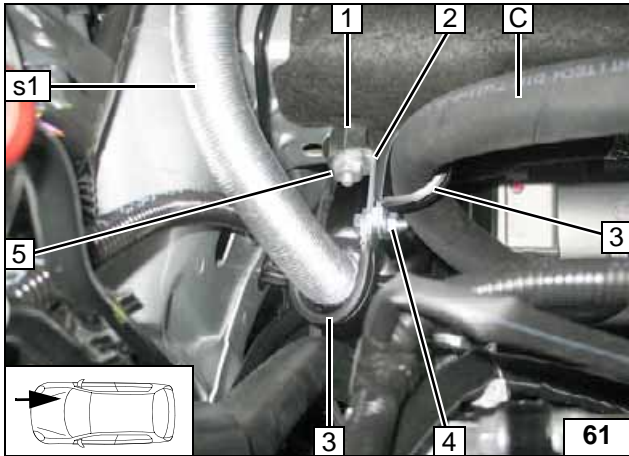
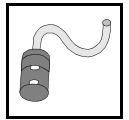

### Combustion Air

Drill out angle bracket **2** on the short leg to 8.5mm dia.

- 1 M8x15 spacer nut, original vehicle stud bolt
- 3 25 mm dia. rubber-coated p-clamp [2x]
- 4 M6x20 bolt, flanged nut
- 5 M8 flanged nut



**Fastening hose C and combustion air pipe s1**

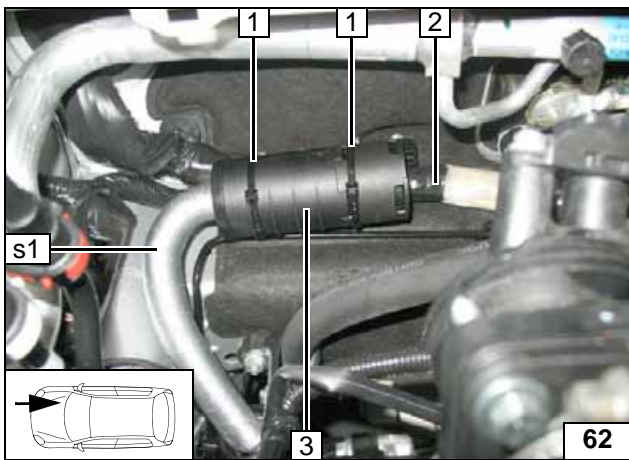

- 1 Cable tie [2x each]
- 2 Original vehicle wiring harness
- 3 Silencer



**Installing silencer**

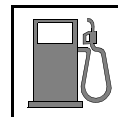

**Fuel**

**CAUTION!**

Open the vehicle's fuel tank cap, ventilate the tank and then re-close the tank lock.

Catch any fuel running off in an appropriate container.

Route fuel line and metering pump wiring harness so that they are protected against stone impact. Unless specified otherwise, always fasten using cable ties.

Provide rub protection for fuel line and wiring harness in areas where there are sharp edges.

**WARNING!**

The fuel line and wiring harness are routed to the metering pump as shown in the wiring harness routing diagram.

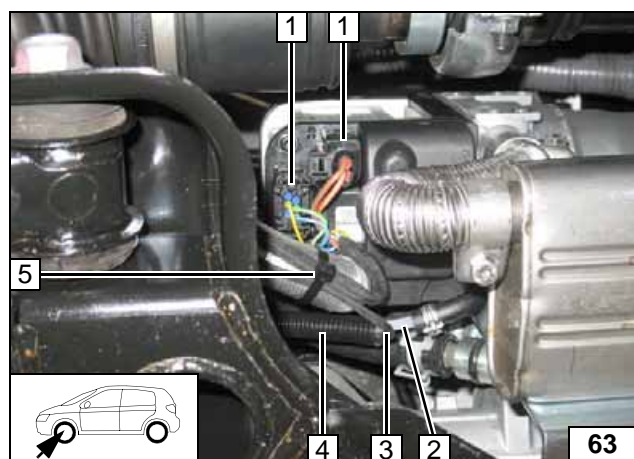

Pull wiring harness of metering pump **3** and fuel line **2** into corrugated tube **4** and route to underbody.

- 1 Heater wiring harness connector [2x]
- 5 Cable tie

**Mounting wiring harnesses**

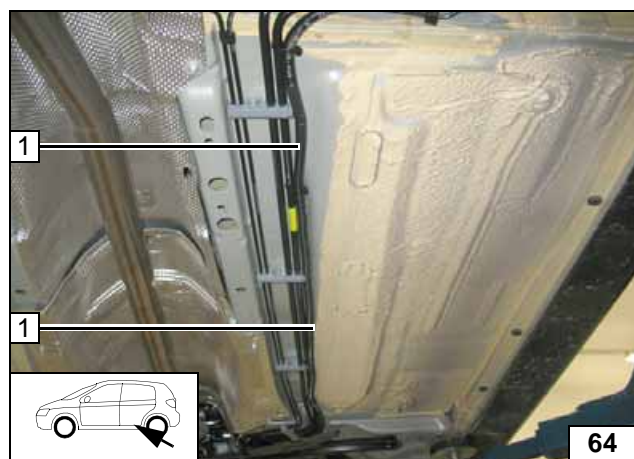

- 1 Fuel line and metering pump wiring harness in corrugated tube

**Routing lines**

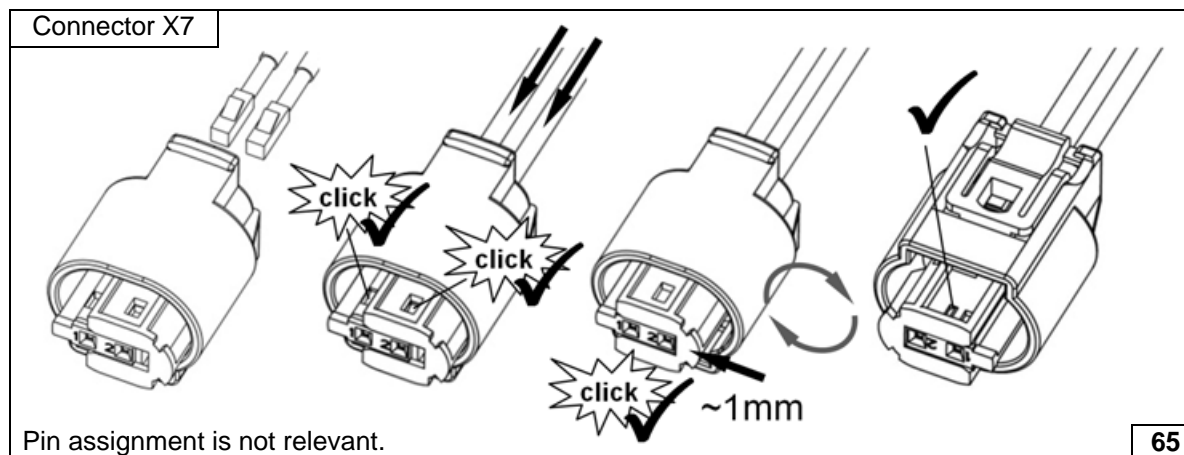

**Completing metering pump connector**

Pin assignment is not relevant.

65

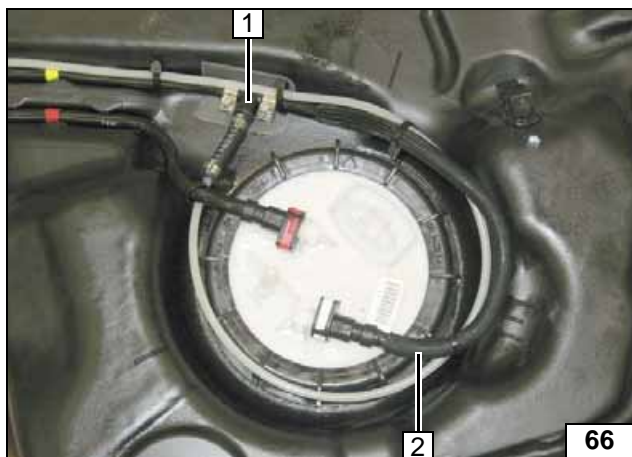
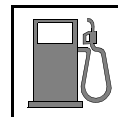

Remove the fuel tank according to the manufacturer's instructions. Cut off fuel supply line 2 at position 1.



Fuel extraction

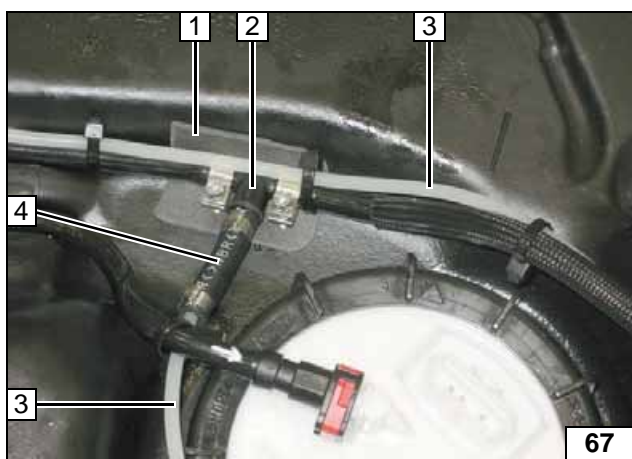

- 1 Glue on insulation strip
- 2 8x5x8 fuel standpipe, 10 mm dia.hose clamp [2x]
- 3 Fuel line
- 4 Hose section, 10mm dia. clamp [2x]



Installing fuel stand-pipe

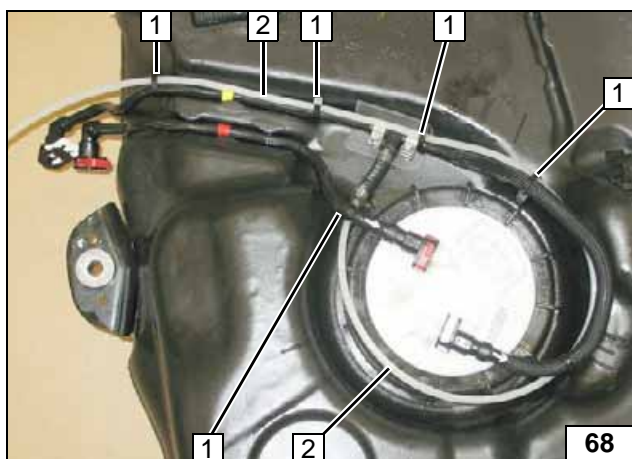

Fasten fuel line 2 with cable tie 1. Install fuel tank in accordance with manufacturer's instructions.



Mounting fuel line

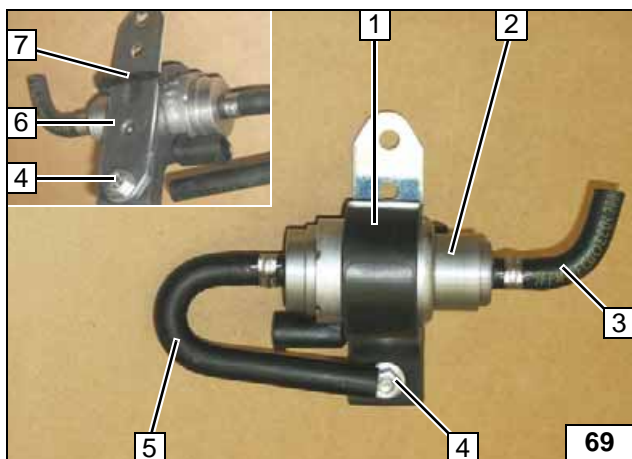

**Focus / C-Max**

- 1 Metering pump mount
- 2 Metering pump
- 3 90° moulded hose, 10 mm dia. clamp
- 4 M6x25 bolt, support angle bracket, flanged nut
- 5 180° moulded hose, 10 mm dia. clamp
- 6 Perforated bracket
- 7 Cable tie

Premounting metering pump

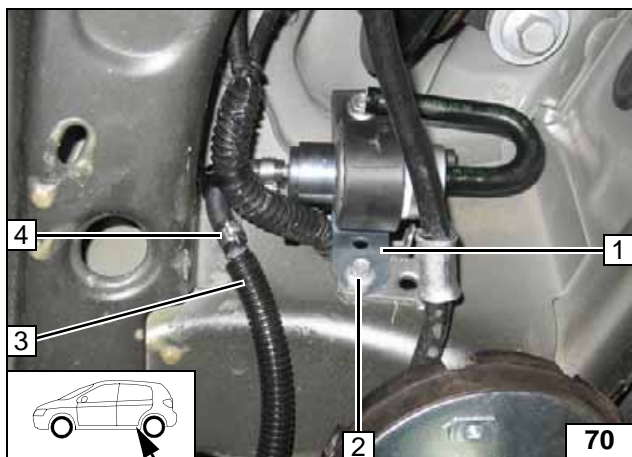
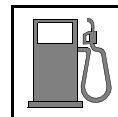

- 1 Perforated bracket
- 2 Original vehicle bolt
- 3 Fuel line of fuel standpipe in corrugated tube
- 4 10 mm dia. clamp



**Installing metering pump**



Check the position of the components; adjust if necessary. Check that they have freedom of movement.



**Connecting metering pump**

- 1 Heater fuel line
- 2 10 mm dia. clamp
- 3 Cable tie
- 4 Metering pump wiring harness, connector X7 mounted

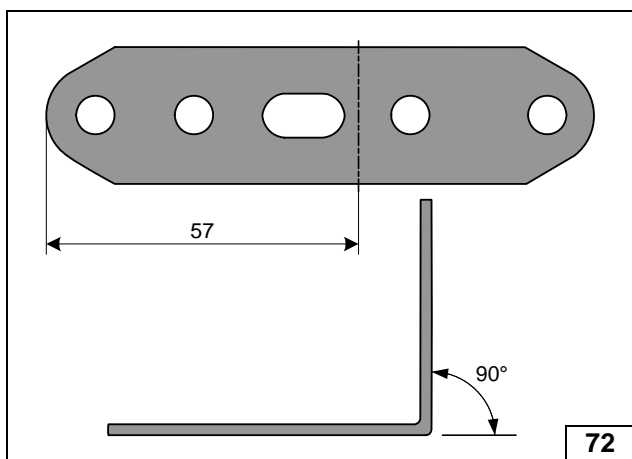

**Grand C-Max**

**Angling down perforated bracket**

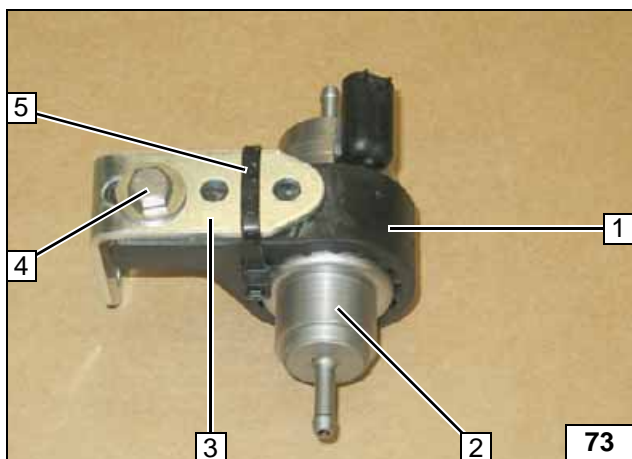

- 1 Metering pump mount
- 2 Metering pump
- 3 Perforated bracket
- 4 M6x25 bolt, washer, support angle bracket, flanged nut
- 5 Cable tie

**Premounting metering pump**

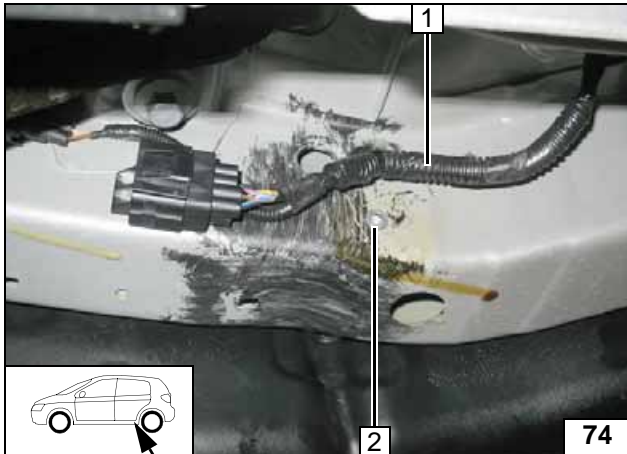
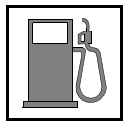

Detach retaining clip of original vehicle wiring harness **1** at position **2**.

- 2** Drill out 9.1 mm dia. hole, rivet nut



**Installing rivet nut**



- 1** M6x20 bolt, spring lockwasher
- 2** Perforated bracket



**Installing metering pump**

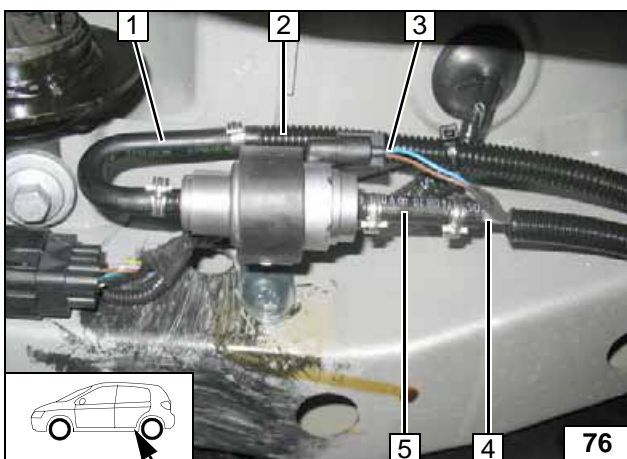

- 1** 180° moulded hose, 10 mm dia. clamp [2x]
- 2** Fuel line of fuel standpipe in corrugated tube
- 3** Metering pump wiring harness, connector X7 mounted
- 4** Heater fuel line
- 5** Hose section, 10mm dia. clamp [2x]



**Connecting metering pump**

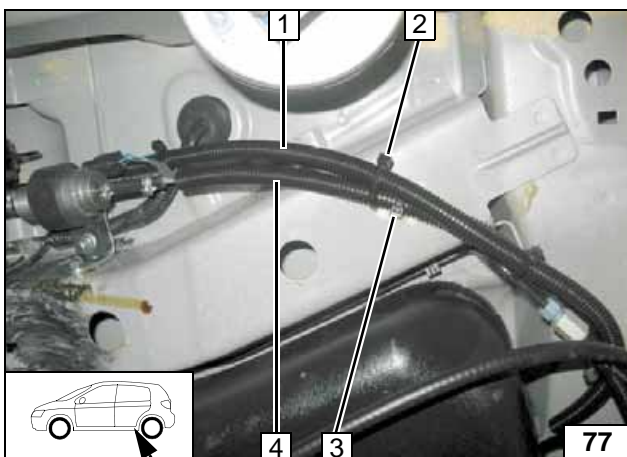

Check the position of the components; adjust if necessary. Check that they have freedom of movement.

- 1** Fuel line of fuel standpipe in corrugated tube
- 2** Cable tie
- 3** Adhesive base, cable tie
- 4** Heater fuel line and metering pump wiring harness in corrugated tube



**Routing lines**

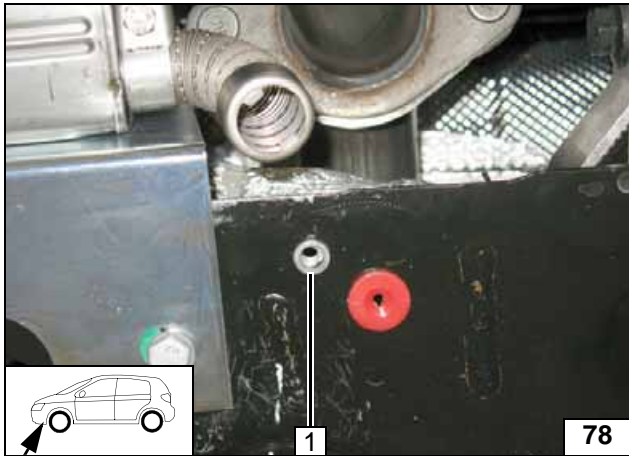
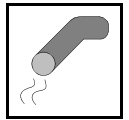

### Exhaust Gas

- 1 Drill out 9.1 mm dia. hole, rivet nut

Installing rivet nut

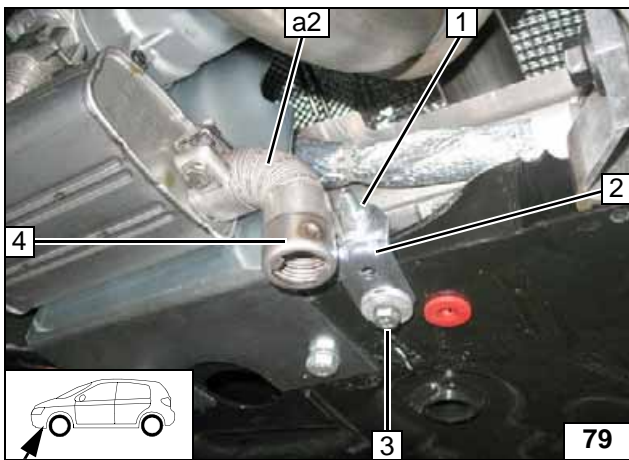

- 1 M6x20 bolt, flanged nut
- 2 Angle bracket
- 3 M6x20 bolt, spring lockwasher, large diameter washer
- 4 P-clamp

Attaching exhaust pipe a2



## Final Work

### WARNING!

Reassemble the components in reverse order. Check all hoses, clamps and all electrical connections for firm seating. Insulate and tie back loose lines. Only use manufacturer-approved coolant. Spray the heater components with anti-corrosion wax (Tectyl 100K).



- Connect the battery.
- Fill and bleed the coolant circuit according to the vehicle manufacturer's instructions.
- Program MultiControl CAR, teach Telestart transmitter.
- Make settings on the A/C control panel according to the 'operating instructions'.
- Place the 'Switch off parking heater before refuelling' caution label near the filler neck.
- For initial startup and function check, please see installation instructions.

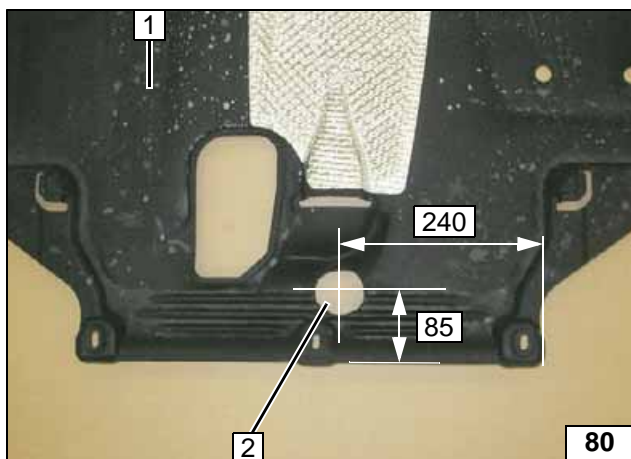

- 1 Underride protection
- 2 60 mm dia. hole

Cutting out  
underride  
protection

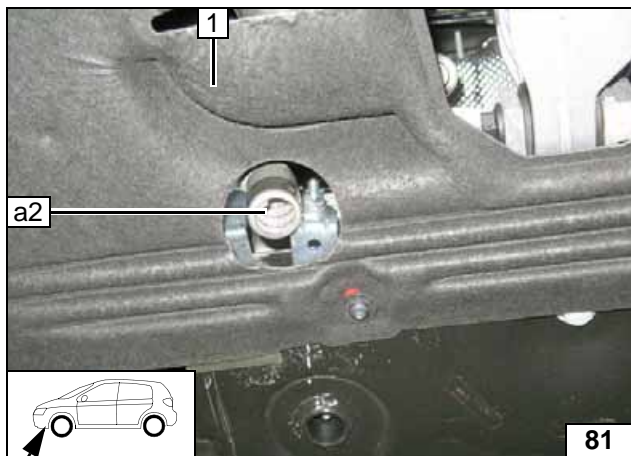

Mount underride protection of engine 1. Align exhaust pipe a2 flush with underride protection 1. Ensure sufficient distance from neighbouring components.



Aligning  
exhaust  
pipe a2

Webasto Thermo & Comfort SE  
Postfach 1410  
82199 Gilching  
Germany  
Internet: [www.webasto.com](http://www.webasto.com)  
Technical Extranet:  
<http://dealers.webasto.com>



## Operation of Manual A/C for Focus

Please remove page and add to the vehicle operating instructions.

**Note:**

We recommend matching the heating time to the driving time.

Heating time = driving time

**Example:**

For a driving time of approx. 20 min. (in one direction), we recommend not exceeding a switch-on time of 20 min.

Passenger compartment monitoring, if installed, must be deactivated in addition to the vehicle settings for the heating operation.

For instructions on deactivation, please refer to the operating instructions of the vehicle.

Before parking the vehicle, make the following settings:

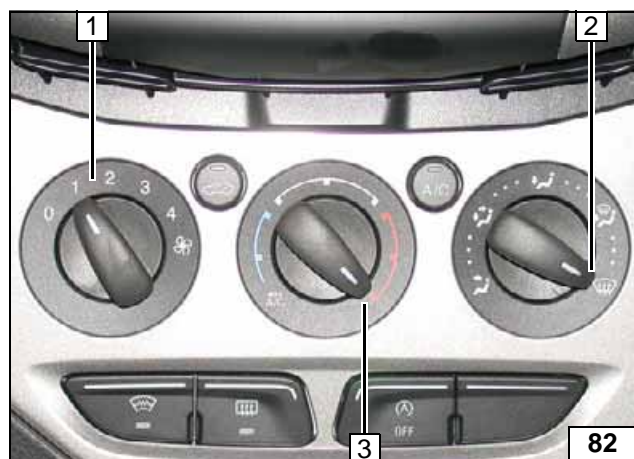

- 1 Set fan to level '1', or max. '2'
- 2 Air outlet to windscreen
- 3 Set temperature to 'max.'



A/C control panel

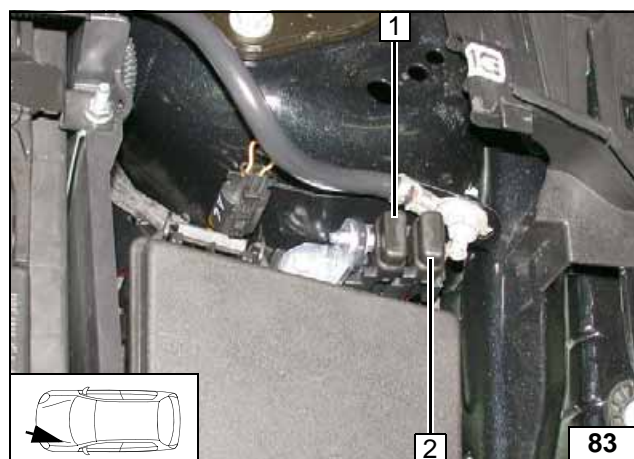

- 1 30A passenger compartment main fuse F2
- 2 20A heater fuse F1

Engine compartment fuses

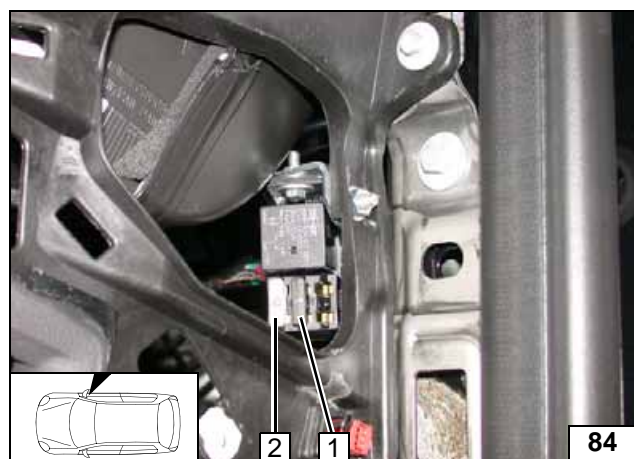

- 1 1A heater control fuse F3
- 2 25A fan fuse F4

Passenger compartment fuses



### Operation of Manual A/C for C-Max / Grand C-Max

Please remove page and add to the vehicle operating instructions.

**Note:**

We recommend matching the heating time to the driving time.  
 Heating time = driving time

**Example:**

For a driving time of approx. 20 min. (in one direction), we recommend not exceeding a switch-on time of 20 min.

Passenger compartment monitoring, if installed, must be deactivated in addition to the vehicle settings for the heating operation.

For instructions on deactivation, please refer to the operating instructions of the vehicle.

Before parking the vehicle, make the following settings:



- 1 Set fan to level '1', or max. '2'
- 2 Air outlet to windscreen
- 3 Set temperature to 'max.'



**A/C control panel**

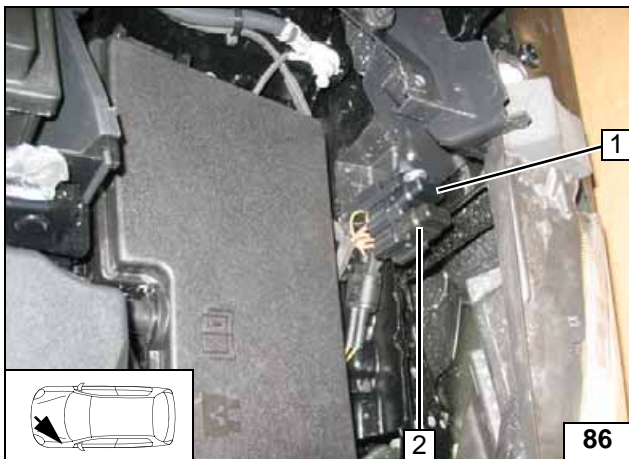

- 1 30A passenger compartment main fuse F2
- 2 20A heater fuse F1

**Engine compartment fuses**

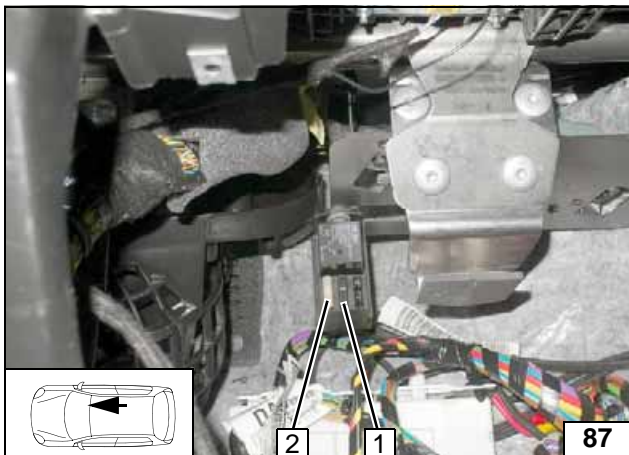

- 1 1A heater control fuse F3
- 2 25A fan fuse F4

**Passenger compartment fuses**



## Operation of Automatic A/C for Focus

Please remove page and add to the vehicle operating instructions.

### Note:

We recommend matching the heating time to the driving time.

Heating time = driving time

### Example:

For a driving time of approx. 20 min. (in one direction), we recommend not exceeding a switch-on time of 20 min.

Passenger compartment monitoring, if installed, must be deactivated in addition to the vehicle settings for the heating operation.

For instructions on deactivation, please refer to the operating instructions of the vehicle.

Before parking the vehicle, make the following settings:



Fan speed need not be pre-set.

- 1 Set temperature on both sides to 'HI'
- 2 Air outlet to windscreen



**A/C control panel**

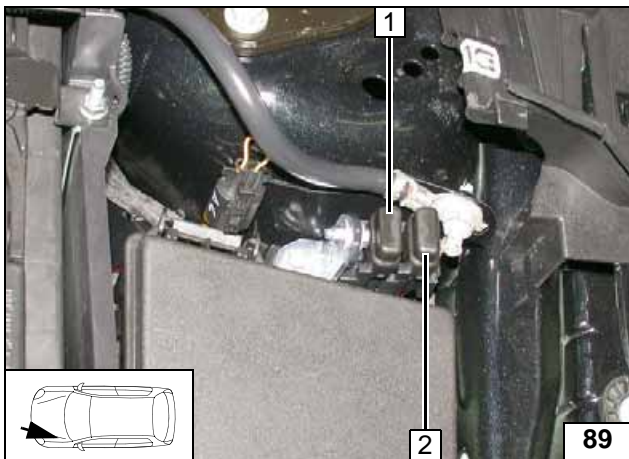

- 1 30A passenger compartment main fuse F2
- 2 20A heater fuse F1

**Engine compartment fuses**

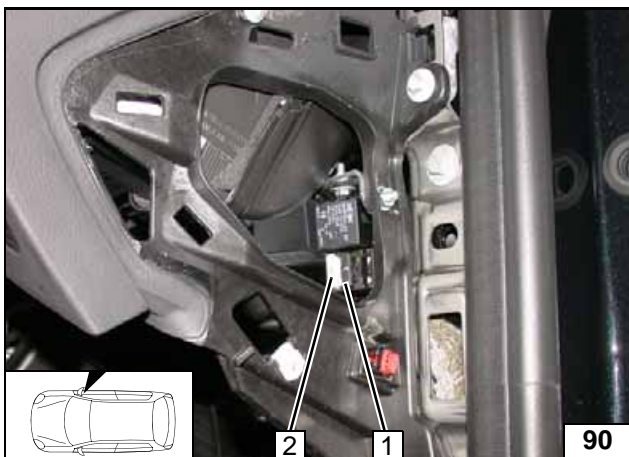

- 1 1A heater control fuse F3
- 2 25A fan fuse F4

**Passenger compartment fuses**



## Operation of Automatic A/C for C-Max / Grand C-Max

Please remove page and add to the vehicle operating instructions.

**Note:**

We recommend matching the heating time to the driving time.  
 Heating time = driving time

**Example:**

For a driving time of approx. 20 min. (in one direction), we recommend not exceeding a switch-on time of 20 min.

Passenger compartment monitoring, if installed, must be deactivated in addition to the vehicle settings for the heating operation.

For instructions on deactivation, please refer to the operating instructions of the vehicle.

Before parking the vehicle, make the following settings:



Fan speed need not be pre-set.

- 1 Set temperature on both sides to 'HI'
- 2 Air outlet to windscreen



**A/C control panel**

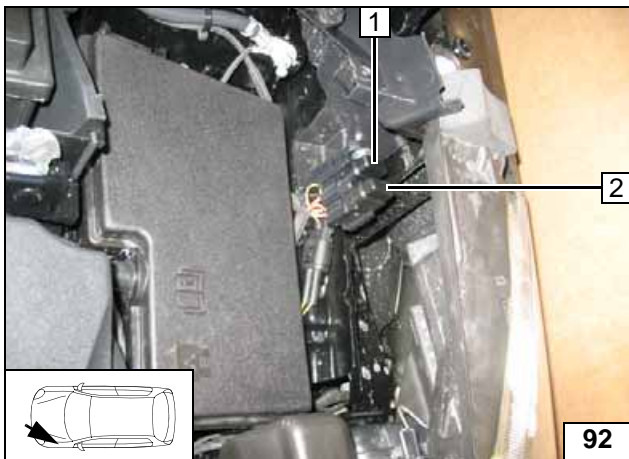

- 1 30A passenger compartment main fuse F2
- 2 20A heater fuse F1

**Engine compartment fuses**

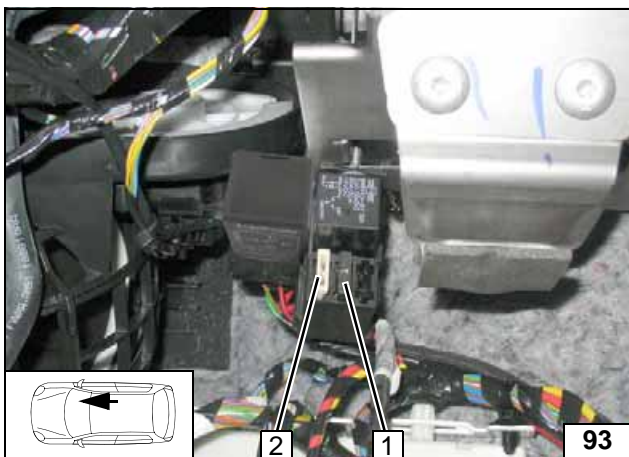

- 1 1A heater control fuse F3
- 2 25A fan fuse F4

**Passenger compartment fuses**