



Water Heater

Thermo Top Evo Parking Heater



Installation Documentation Ford Focus

Validity

Manufacturer	Model	Type	EG BE No. / ABE
Ford	Focus	DB	e13 * 2007 / 46 * 1103 * ...

Motorisation	Fuel	Transmission type	Output in kW	Displacement in cm ³	Engine code
2.0 TDCi	Diesel	SG	103	1997	UF
2.0 TDCi	Diesel	AG	103	1997	UF

SG = manual transmission

AG = automatic transmission

From model year 2011 up to model year 2014

Left-hand drive vehicle

Verified equipment variants: Manual / automatic air-conditioning system
Front fog lights
Headlight washer system

Not verified: Passenger compartment monitoring

Total installation time: approx. 9.5 hours

Ford Focus

Table of Contents

Validity	1	Preparing Installation Location	16
Necessary Components	2	Preparing Heater	16
Installation Overview	2	Installing Heater	18
Information on Total Installation Time	2	Coolant Circuit	19
Information on Operating and Installation Instructions	3	Combustion Air	22
Information on Validity	4	Fuel	23
Technical Information	4	Exhaust Gas	26
Explanatory Notes on Document	4	Final Work	27
Preliminary Work	5	Operating Instructions for Manual A/C	28
Heater Installation Location	5	Operating Instructions for Automatic A/C	29
Preparing Electrical System	6		
Electrical System	9		
MultiControl CAR Option	9		
Manual Air-Conditioning Fan Controller	10		
Automatic Air-Conditioning Fan Controller	12		
Remote Option (Telestart)	15		

Necessary Components

- Basic delivery scope of Thermo Top Evo based on price list
- Installation kit for Ford Focus 2011 Diesel: **1317613B**
- Heater control in accordance with price list and upon consultation with end customer
- In case of Telestart, indicator lamp in accordance with price list and in consultation with end customer
- In case of MultiControl CAR installation: Timer cable extension: **1319724_**
- For MultiControl CAR installation in case of Focus: MultiControl installation frame: **9030077_**

Installation instructions:

- Arrange for the vehicle to be delivered with the tank only about ¼ full.
- The installation location of the push button in case of Telestart or ThermoCall should be confirmed with the end customer.
- Depending on the space required and the vehicle manufacturer's instructions, we recommend the use of a vehicle battery with a higher electrical capacity.

Installation Overview

Legend:

1. Heater
2. Engine compartment fuse holder
3. Passenger compartment relay and fuse holder
4. PWM GW (only in case of automatic air-conditioning)
5. Circulating pump
6. Multi Control CAR
7. Metering pump

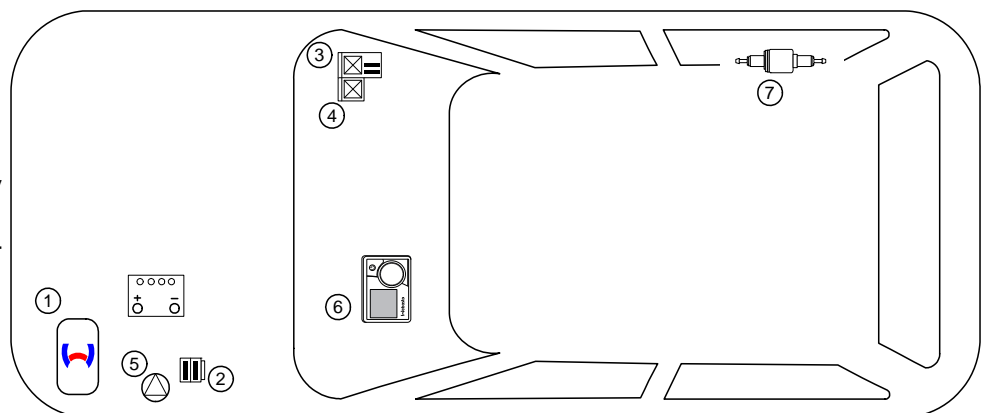

Information on Total Installation Time

The total installation time includes the time needed for mounting and demounting the vehicle-specific components, the heater specific installation time and all other times required for the system integration and initial start-up of the heater.

The total installation time may vary for vehicle equipment other than provided.

Information on Operating and Installation Instructions

1 Important information (not complete)

1.1 Installation and repair



The improper installation or repair of Webasto heating and cooling systems can cause fire or the leakage of deadly carbon monoxide, leading to serious injury or death.



To install and repair Webasto heating and cooling systems you need to have completed a special company training course and have the appropriate technical documentation, special tools and special equipment.



Installation and repair may ONLY be carried out by persons trained and certified in a Webasto training course. NEVER try to install or repair Webasto heating or cooling systems if you have not completed a Webasto training course, you do not have the necessary technical skills and you do not have the technical documentation, tools and equipment available to ensure that you can complete the installation and repair work properly.

Only use genuine Webasto parts. See the Webasto air and water heaters accessories catalogue for this purpose.

1.2 Operation

To ensure safe operation, we recommend having the heater checked every two years by an authorised Webasto dealer, especially when used over a long period and/or under extreme environmental conditions.

Do not operate the heater in closed rooms due to the danger of poisoning and suffocation.

Always switch off the heater before refuelling.

The heater may only be used with the prescribed fuel diesel (DIN EN 590) or petrol (DIN EN 228).

The heater may not be cleaned with a high-pressure cleaner.

1.3 Please note

ALWAYS follow all Webasto installation and operating instructions and observe all warnings.

To become familiar with and understand all functions and properties of the heater, the operating instructions must be read carefully and observed at all times.

For proper, safe installation and repair work, the installation instructions with all warnings and safety information must be carefully read and observed at all times. Please always contact a workshop authorised by Webasto for all installation and repair work.

Important

Webasto shall assume no liability for defects, damage and injuries resulting from a failure to observe the installation, repair and operating instructions of the information contained in them.

This liability exclusion particularly applies to improper installations and repairs, installations and repairs by untrained persons or in the case of a failure to use genuine spare parts.

The liability due to culpable disregard to life, limb or health and due to damage or injuries caused by a wilful or reckless breach of duty remain unaffected, as does the obligatory product liability.

Installation should be carried out according to the general, standard rules of technology. Unless specified otherwise, fasten hoses, lines and wiring harnesses to original vehicle lines and wiring harnesses using cable ties. Insulate loose wire ends and tie back. Connectors on electronic components must audibly snap into place during assembly.

Sharp edges should be fitted with rub protection. Spray unfinished body areas, e.g. drilled holes, with anti-corrosion wax (Tectyl 100K).

Observe the instructions and guidelines of the respective vehicle manufacturer for demounting and mounting vehicle specific components!

The initial startup is to be executed with the Webasto Thermo Test Diagnosis.

When installing a programmable control module (e.g. a PWM Gateway), the corresponding settings must be checked or adjusted.

2 Statutory regulations governing installation

Guidelines	Thermo Top Evo
Heating Directive ECE R122	E1 00 0258
EMC Directive ECE R10	E1 04 5627

Note

The regulations of these guidelines are binding in the scope of the Directive 70/156/EEC and/or 2007/46/EC (for new vehicle models from 29/04/2009) and should also be observed in countries in which there are no special regulations.

Important

Failure to follow the installation instructions will result in the invalidation of the type approval for the heater and therefore invalidation of the general **homologation of the vehicle**.

Note

The heater is licensed in accordance with paragraph 19, section 3, No. 2b of the StVZO (German Road Traffic Licensing Authority).

2.1 Excerpt from ECE regulation 122 (heating system) paragraph 5 for the installation of the heater

Beginning of excerpt.

ANNEX VII

REQUIREMENTS FOR COMBUSTION HEATERS AND THEIR INSTALLATION

1. GENERAL REQUIREMENTS

1.7.1. A clearly visible tell-tale in the operator's field of view shall inform when the combustion heater is switched on or off.

2. VEHICLE INSTALLATION REQUIREMENTS

2.1. Scope

2.1.1. Subject to paragraph 2.1.2. combustion heaters shall be installed according to the requirements of this Annex.

2.1.2. Vehicles of category O having liquid fuel heaters are deemed to comply with the requirements of this Annex.

2.2. Positioning of heater

2.2.1. Body sections and any other components in the vicinity of the heater must be protected from excessive heat and the possibility of fuel or oil contamination.

2.2.2. The combustion heater shall not constitute a risk of fire, even in the case of overheating. This requirement shall be deemed to be fulfilled if the installation ensures an adequate distance to all parts and suitable ventilation, by the use of fire resistant materials or by the use of heat shields.

2.2.3. In the case of M2 and M3 vehicles, the heater must not be positioned in the passenger compartment. However, an installation in an effectively sealed envelope which also complies with the conditions in paragraph 2.2.2 may be used.

2.2.4. The label referred to in paragraph 1.4 or a duplicate, must be positioned so that it can be easily read when the heater is installed in the vehicle.

2.2.5. Every reasonable precaution should be taken in positioning the heater to minimise the risk of injury and damage to personal property.

2.3. Fuel supply

2.3.1. The fuel filler must not be situated in the passenger compartment and must be provided with an effective cap to prevent fuel spillage.

2.3.2. In the case of liquid fuel heaters, where a supply separate to that of the vehicle is provided, the type of fuel and its filler point must be clearly labelled.

2.3.3. A notice, indicating that the heater must be shut down before refuelling, must be affixed to the fuelling point. In addition a suitable instruction must be included in the manufacturer's operating manual.

2.4. Exhaust system

2.4.1. The exhaust outlet must be located so as to prevent emissions from entering the vehicle through ventilators, heated air inlets or opening windows.

2.5. Combustion air inlet

2.5.1. The air for the combustion chamber of the heater must not be drawn from the passenger compartment of the vehicle.

2.5.2. The air inlet must be so positioned or guarded that blocking by rubbish or luggage is unlikely.

2.6. Heating air inlet

2.6.1. The heating air supply may be fresh or recirculated air and must be drawn from a clean area not likely to be contaminated by exhaust fumes emitted either by the propulsion engine, the combustion heater or any other vehicle source.

2.6.2. The inlet duct must be protected by mesh or other suitable means.

2.7. Heating air outlet

2.7.1. Any ducting used to route the hot air through the vehicle must be so positioned or protected that no injury or damage could be caused if it were to be touched.

2.7.2. The air outlet must be so positioned or guarded that blocking by rubbish or luggage is unlikely.

End of excerpt.

In multilingual versions the German language is binding.

Ford Focus

Information on Validity

This installation documentation applies to Ford Focus Diesel vehicles - for validity, see page 1 - from model year 2011 to model year 2014, assuming technical modifications to the vehicle do not affect installation, any liability claims excluded. Depending on the vehicle version and equipment, modifications may be necessary during installation with respect to this 'installation documentation'.

Vehicle and engine types, equipment variants and other specifications not listed in this installation documentation have not been tested. However, installation according to this installation documentation may be possible.

Technical Information

Special Tools

- Hose clamp pliers for auto-tightening hose clamps
- Hose clamp pliers for Clic hose clamps of type W
- Automatic wire stripper, 0.2 - 6mm²
- Crimping pliers for cable lug / tab connector, 0.5 - 6mm²
- Torque wrench for 2.0 - 10 Nm
- Hose clamping pliers
- Metric thread-setter kit
- Punching tool, 60 mm dia.
- Deep-hole marker
- Webasto Thermo Test Diagnosis with current software

Dimensions

- All dimensions are in mm.















Tightening torque values

- Tightening torque values of 5x13 heater bolts and 5x11 heater stud bolts = 8Nm.
- Tightening torque value of 5x15 water connection piece retaining plate bolt = 7Nm.
- Tighten other bolt connections in accordance with manufacturer's instructions or in accordance with state-of-the-art-technology.

Explanatory Notes on Document

You will find an identification mark on the outside top right corner of the page in question to provide you with a quick overview of the individual working steps.

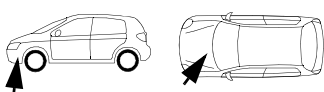
Special features are highlighted using the following symbols:

Mechanical System		Specific risk of injury or fatal accidents.	
Electrical System		Specific risk due to electrical voltage.	
Coolant Circuit		Specific risk of damage to components.	
Combustion Air		Specific risk of fire and explosion.	
Fuel		Reference to general installation instructions of the Webasto components or to the manufacturer's vehicle-specific documents.	
Exhaust Gas		Reference to a special technical feature.	
Software		The arrow in the vehicle icon indicates the position on the vehicle and the viewing angle.	
		Tightening torque according to the manufacturer's vehicle-specific documents.	

Ford Focus

Preliminary Work

Vehicle

- Open the fuel tank cap.
- Ventilate the fuel tank.
- Close the fuel tank cap again.
- Depressurise the cooling system.
- Disconnect and remove the battery.
- Remove the engine cover.
- Drain the coolant according to the manufacturer's instructions.
- Remove the air filter.
- Remove the intake hose.
- Remove the engine underdrive protection.
- Remove the underbody trim on the right next to the tank.
- Detach the heat protection trim of the exhaust system in the area of the tank.
- Remove the tank.
- Remove the footwell trim on the front passenger's side.
- Remove the glove box.
- Removing shift lever trim
- Remove the trim of the centre console.
- Remove the A/C control panel in accordance with the manufacturer's instructions.
- Remove the A-pillar trim of the footwell on the front passenger's side (only in case of Telestart).

Heater

- Remove years that do not apply from the type and duplicate label.
- Attach the duplicate label (type label) visibly in the appropriate place in the engine compartment.

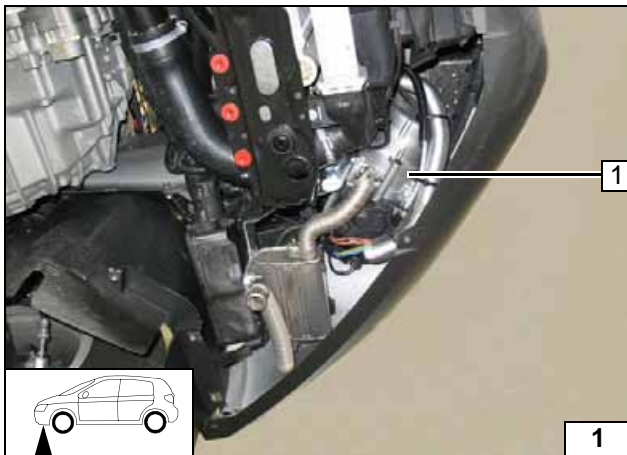

Heater Installation Location

- 1 Heater

Installation location

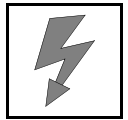

Preparing Electrical System

Wire sections retain their numbering in the entire document.

Manual air-conditioning

- ① Red (rt) wire of fan wiring harness
- ② Black (sw) wire of fan wiring harness

Assigning wires

Connecting wires to passenger compartment relay and fuse holder

Dismantling metering pump connector

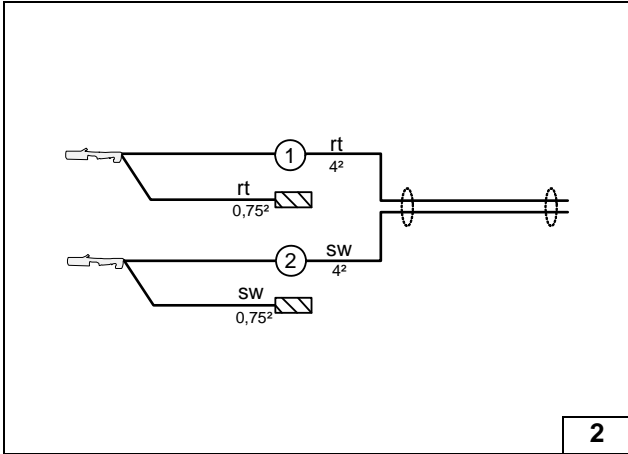

2

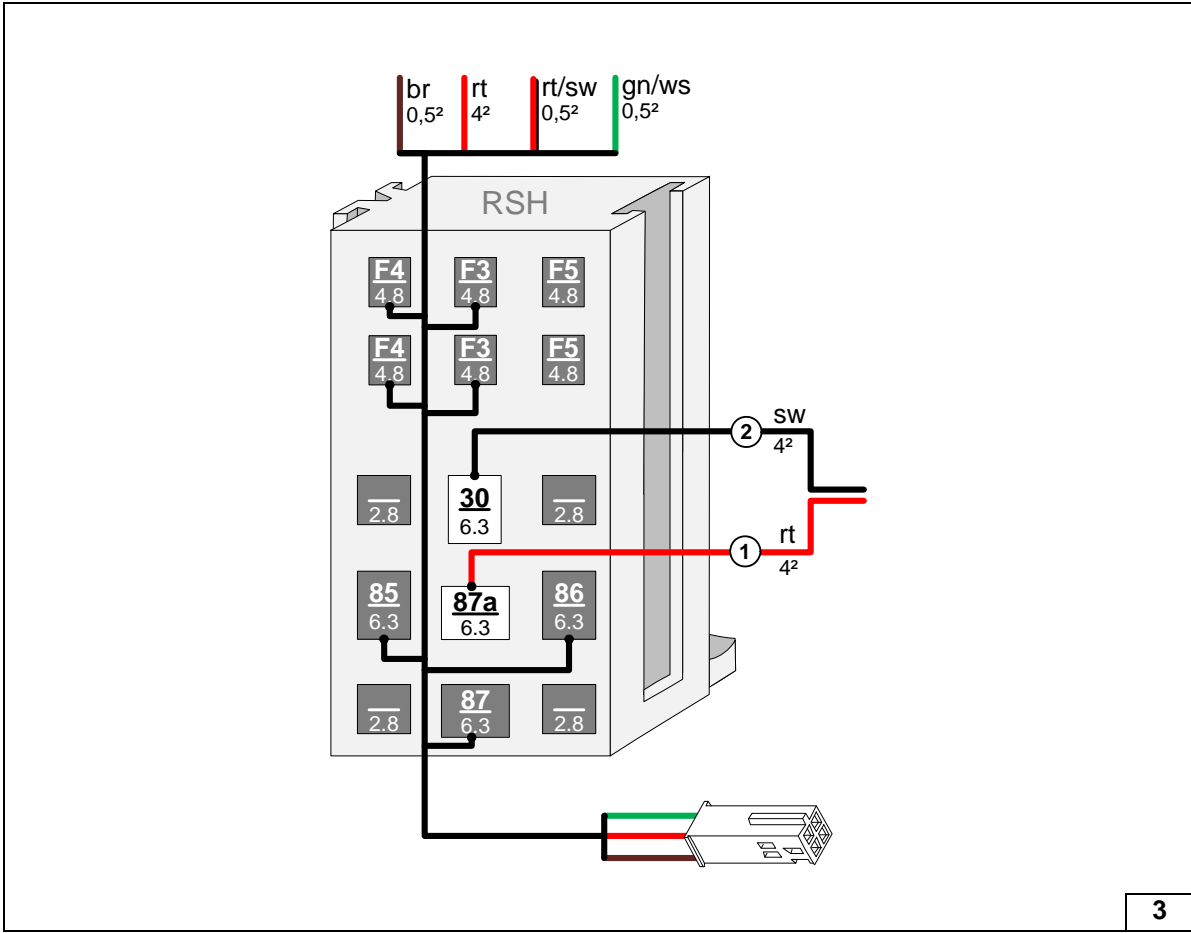

3

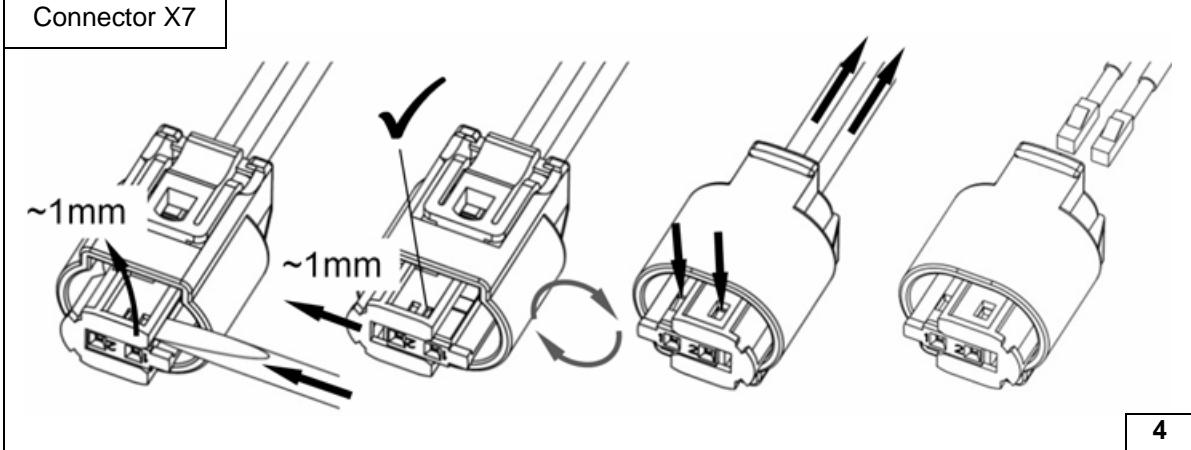

4

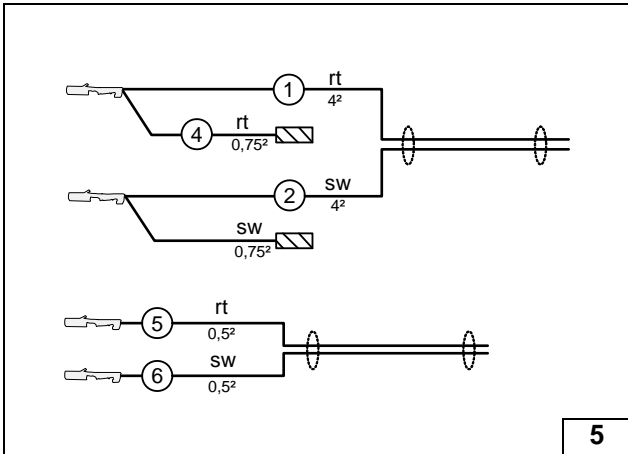
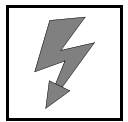

Automatic air-conditioning

- ① Red (rt) wire of fan wiring harness
- ② Black (sw) wire of fan wiring harness
- ⑤ Red (rt) wire from wiring harness of PWM control
- ⑥ Black (sw) wire from wiring harness of PWM control

Preparing / assigning wiring harnesses

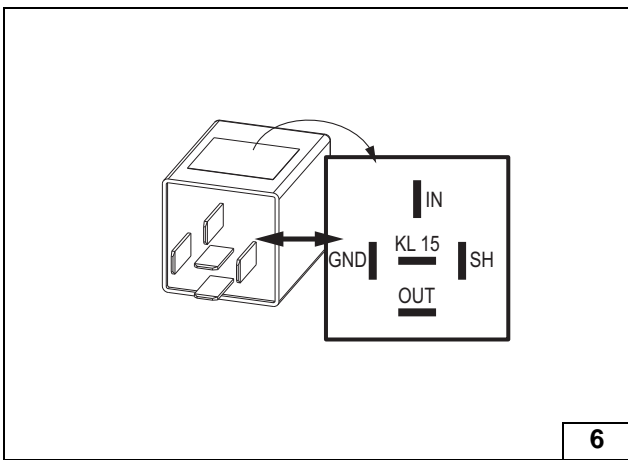

Check the PWM Gateway settings when starting up the heater and adjust if necessary.



Settings:

- Duty cycle: 37%
- Frequency: 400Hz
- Voltage: not relevant
- Function: Low side

View of PWM GW

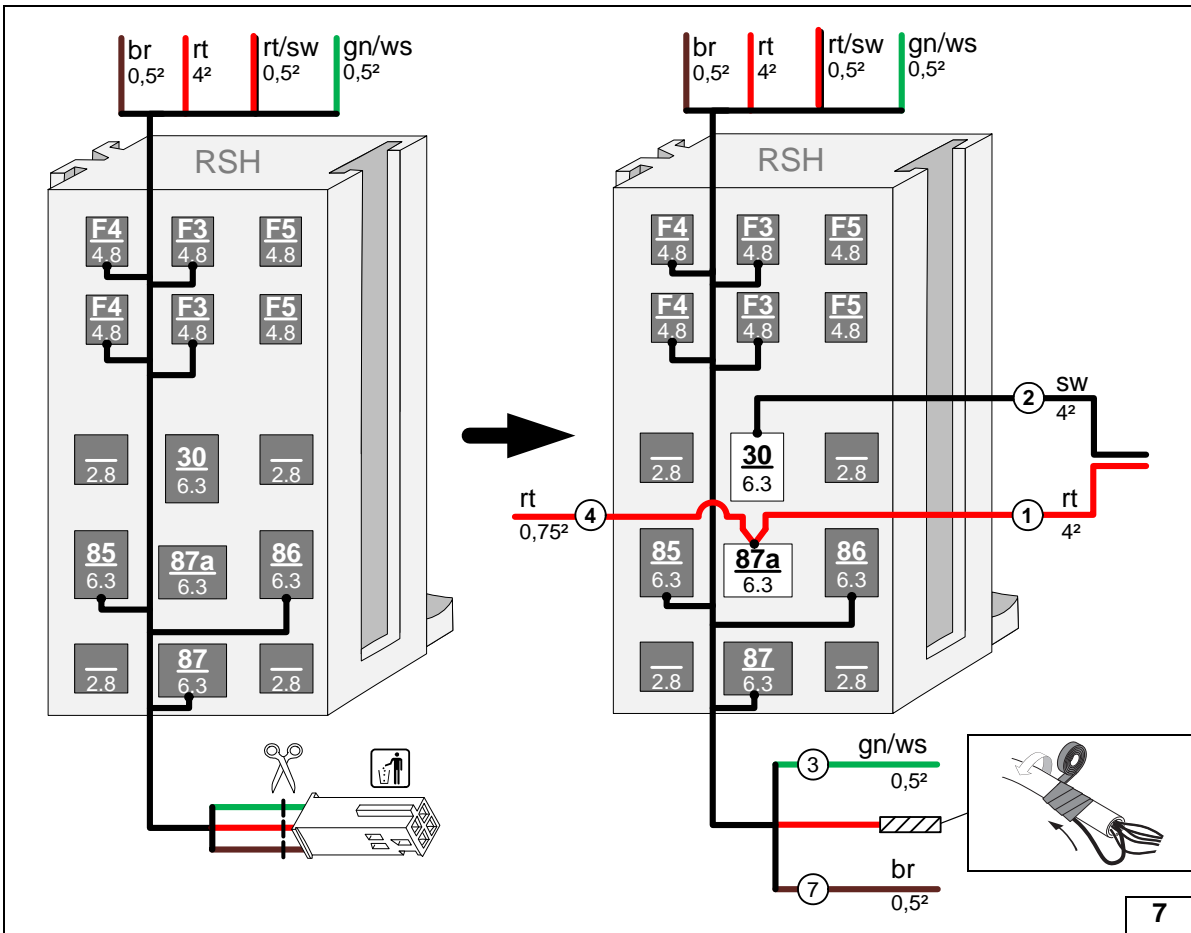

Preparing passenger compartment relay and fuse holder / connecting / assigning wires

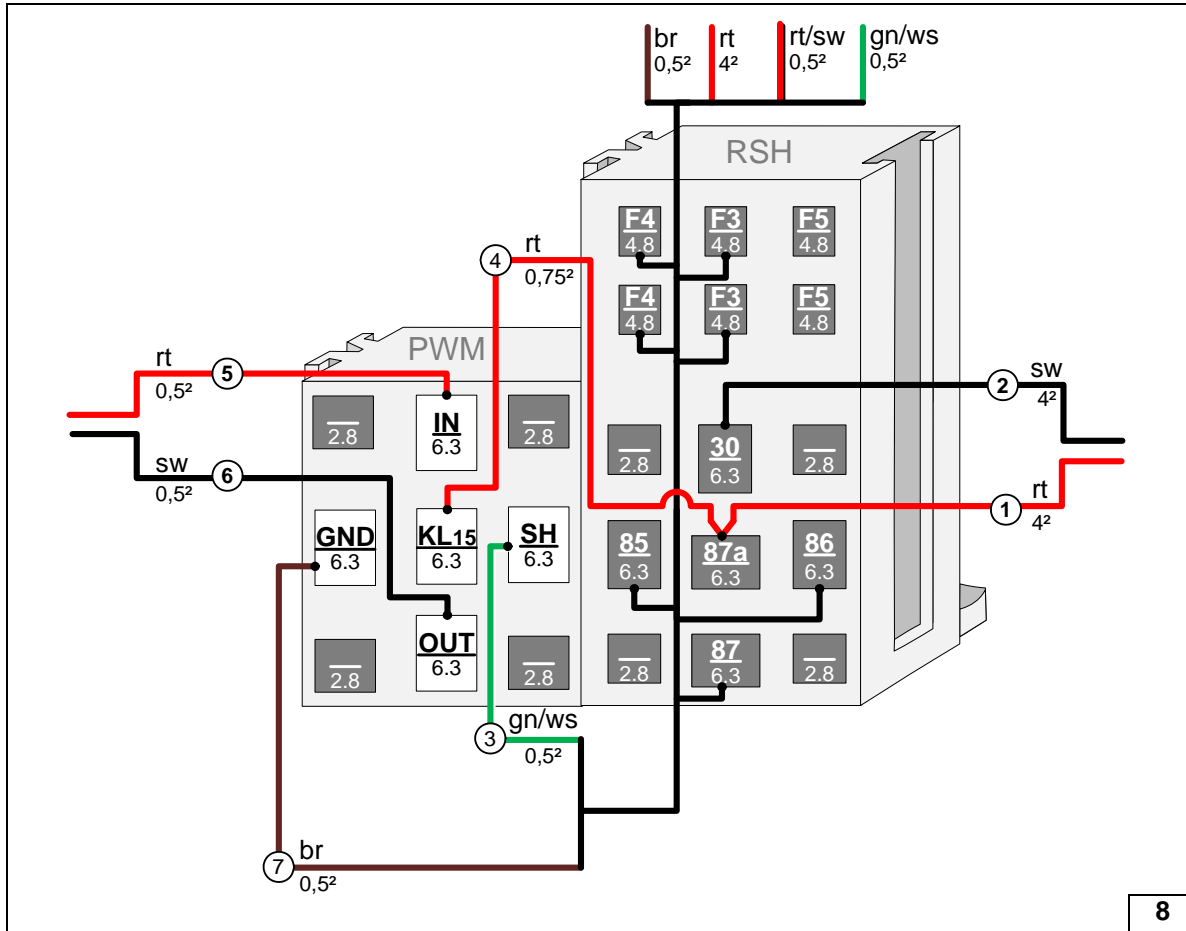

Interlocking PWM GW socket and passenger compartment relay holder, connecting wires



Electrical System

Positive and earth wire

- 1 Earth wire, 8 mm dia. cable lug at original vehicle earth support point
- 2 Positive wire on positive battery terminal

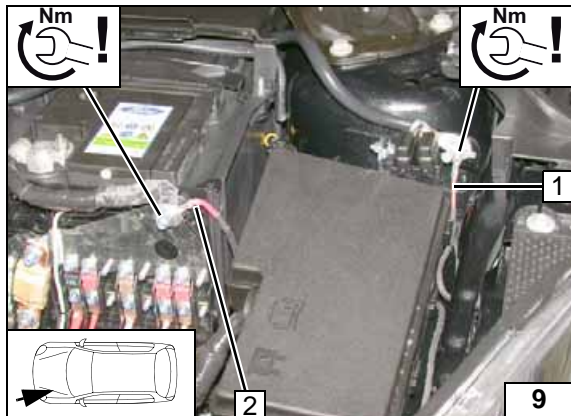

Wiring harness pass through

- 1 Protective rubber plug

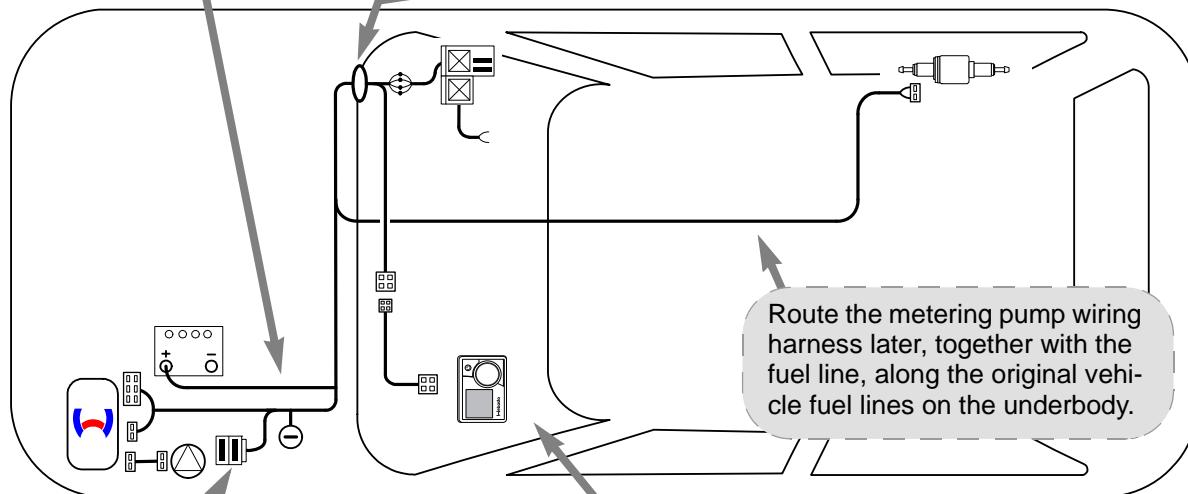
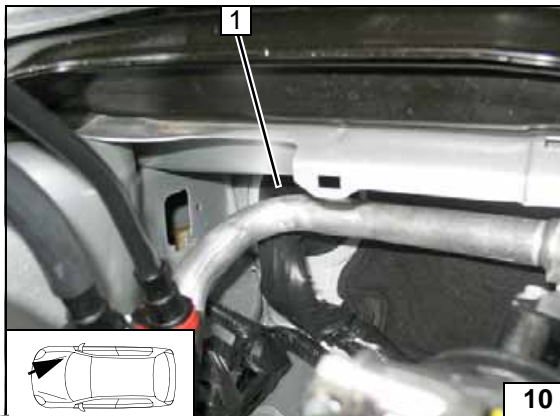

Wiring harness routing diagram

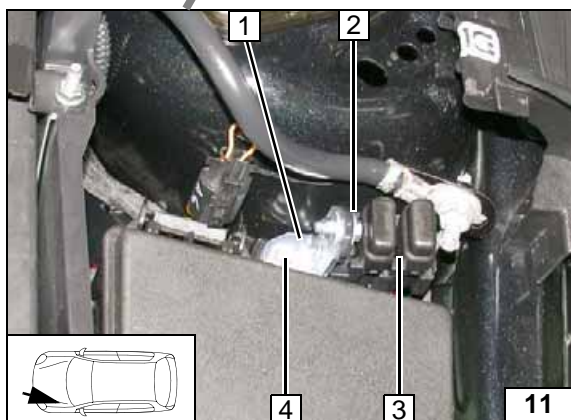

Engine compartment fuse holder

- 1 Angle bracket
- 2 M5x16 bolt, large diameter washer [2x], retaining plate of fuse holder, nut
- 3 Fuses F1-2
- 4 M6x20 bolt, flanged nut, existing hole

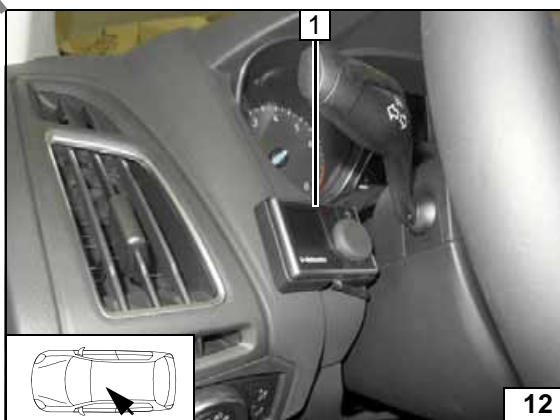

MultiControl CAR Option

Use timer cable extension when installing MultiControl CAR.

- 1 MultiControl CAR bracket



Manual Air-Conditioning Fan Controller

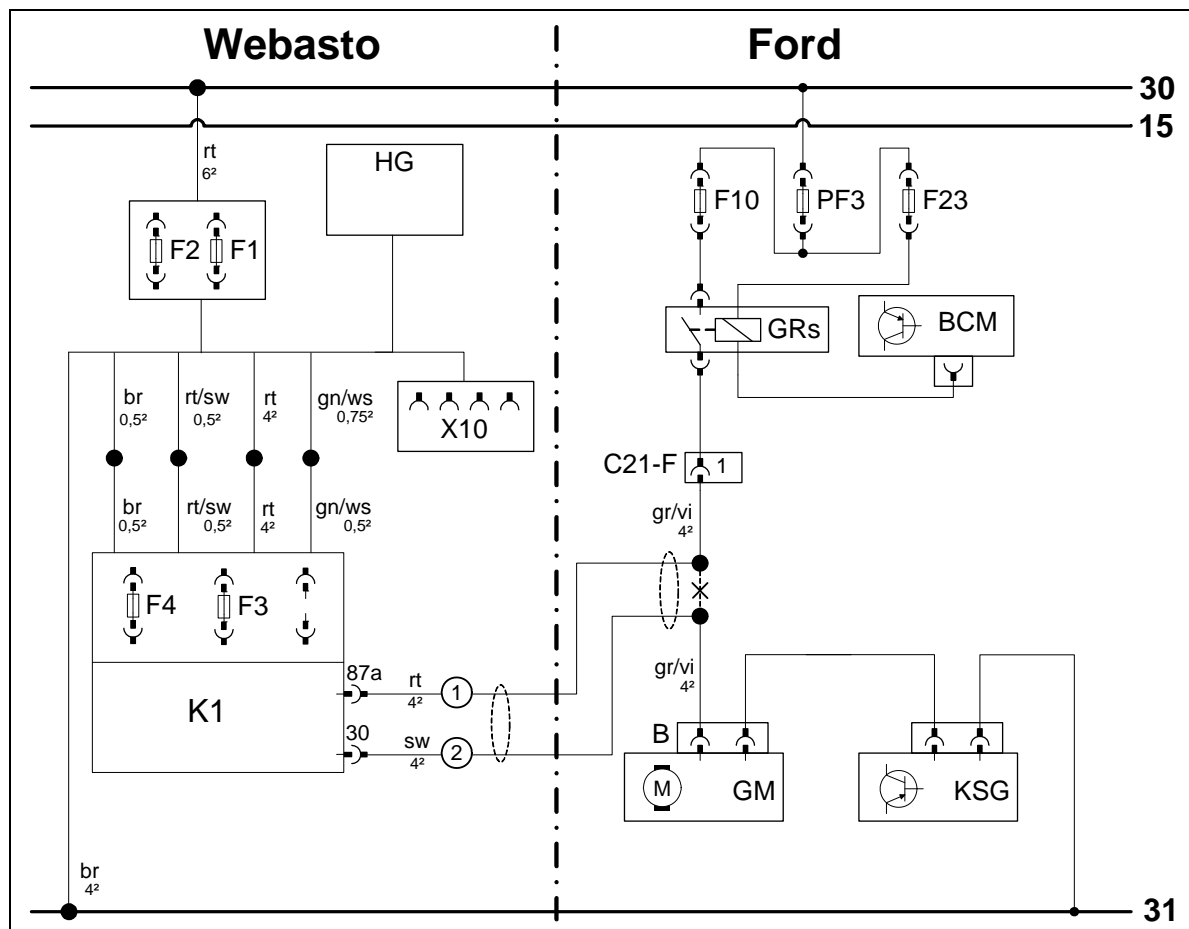

System wiring diagram

Webasto components		Vehicle components		Colours and symbols	
HG	TT-Evo heater	F10	40A fuse	rt	red
F1	20A fuse	PF3	100A fuse	sw	black
F2	30A fuse	F23	5A fuse	gn	green
X10	4-pin connector of heater control	BCM	Body control unit	ws	white
F3	1A fuse	GRs	Fan relay	br	brown
F4	25A fuse	C21-F	Connector	gr	grey
K1	Fan relay	KSG	A/C control unit	vi	violet
		GM	Fan motor		
		B	Fan motor connector		
				X	Cutting point
				Wiring colours may vary.	

Legend

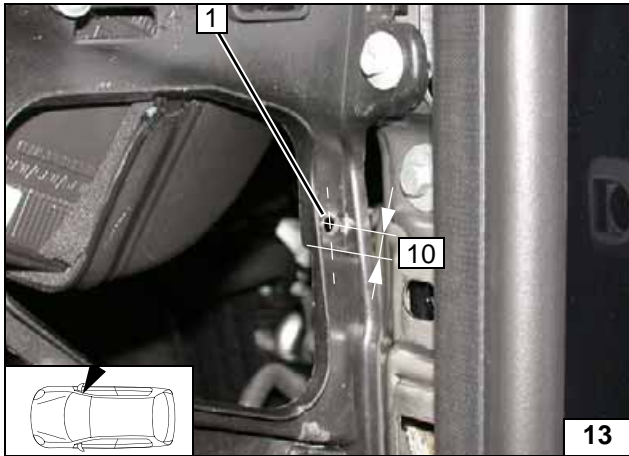
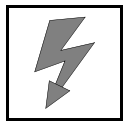

Produce all following electrical connections as shown in the wiring diagram.

- 1 6.5 mm dia. hole

Hole for passenger compartment relay and fuse holder

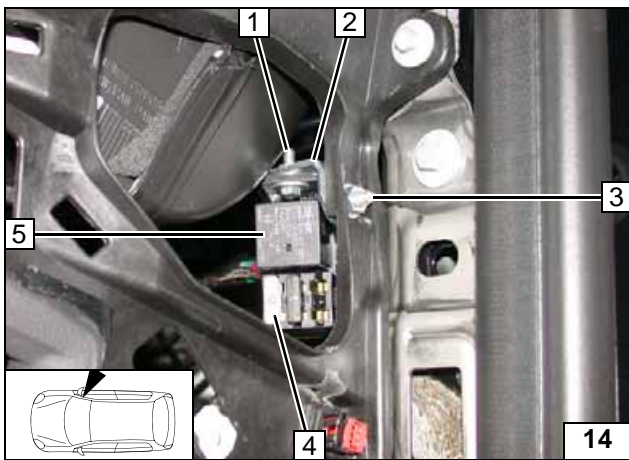

- 1 M5x16 bolt, large diameter washer, passenger compartment relay and fuse holder, large diameter washer, nut
- 2 Angle bracket
- 3 M6x20 bolt, flanged nut
- 4 25A fuse F4
- 5 Relay K1

Installing passenger compartment relay and fuse holder

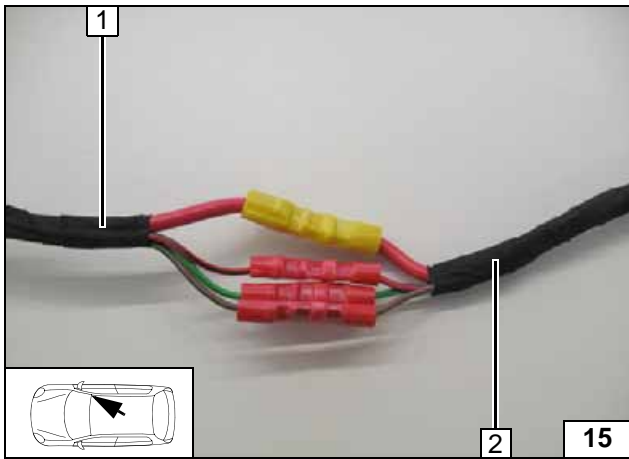

- 1 Passenger compartment relay and fuse holder wiring harness
- 2 Heater wiring harness

Connecting same colour wires of wiring harnesses

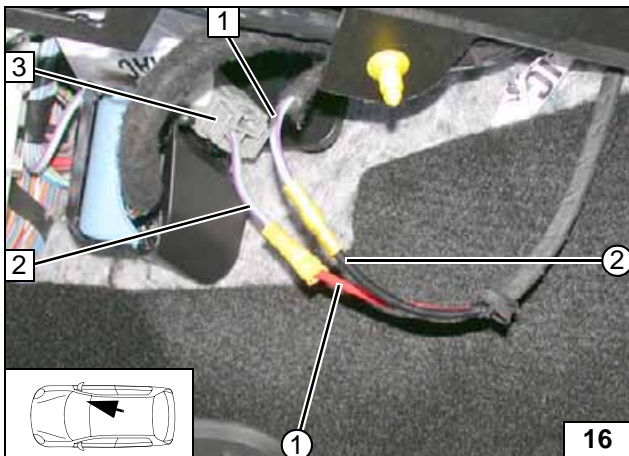

- 1 Grey/violet (gr/vi) wire of fan motor
- 2 Grey/violet (gr/vi) wire of connector C21-F / pin 1
- 3 Connector C21-F
- ① Red (rt) wire of K1/87a, fan wiring harness
- ② Black (sw) wire of K1/30, fan wiring harness

Connecting fan motor

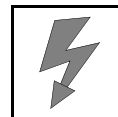

Automatic Air-Conditioning Fan Controller

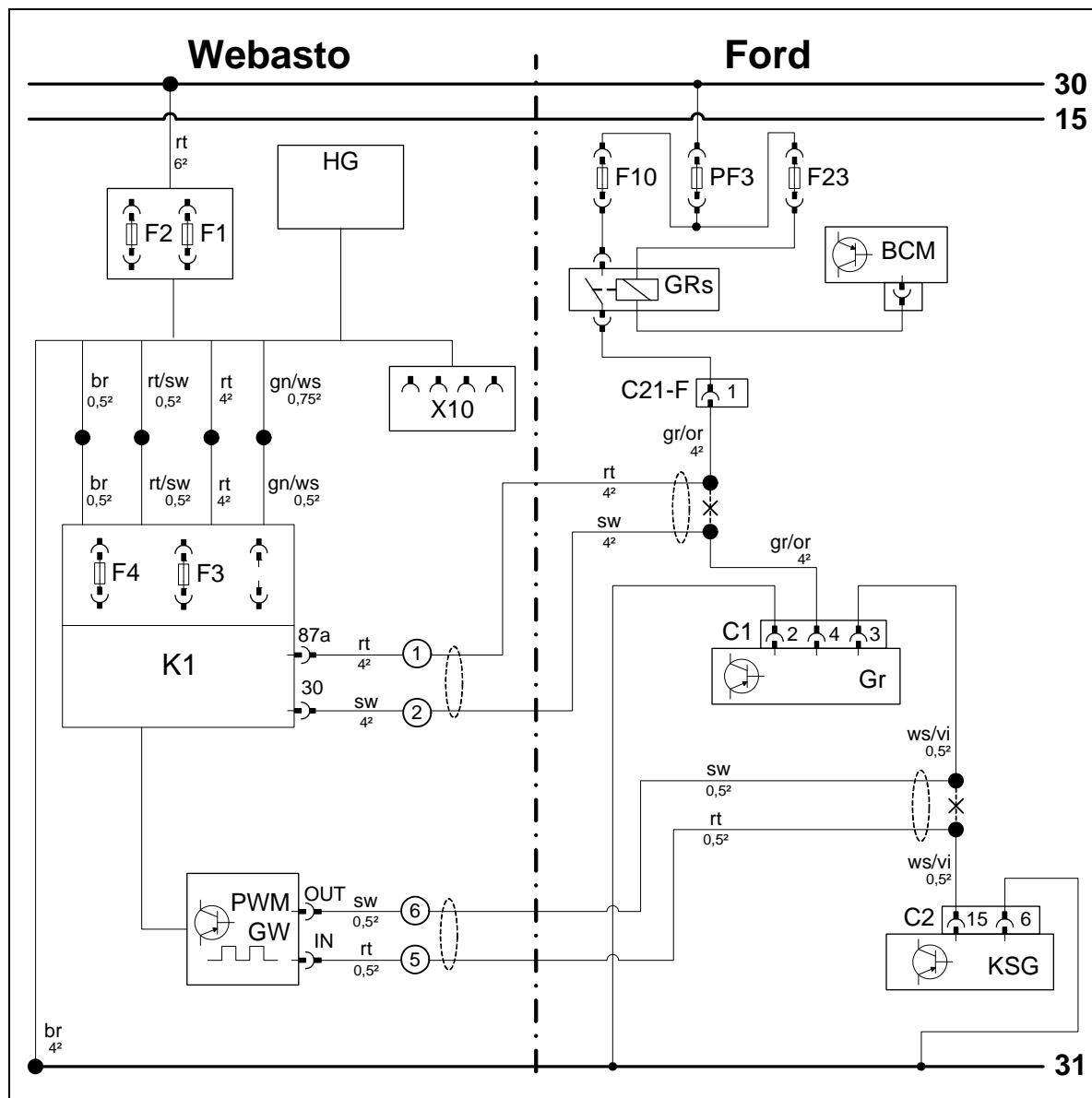

System wiring diagram

Webasto components		Vehicle components		Colours and symbols	
HG	TT-Evo heater	F23	5A fuse	rt	red
F1	20A fuse	F10	40A fuse	sw	black
F2	30A fuse	PF3	100A fuse	gn	green
X10	4-pin connector of heater control	BCM	Body control unit	br	brown
F3	1A fuse	GRs	Fan relay	ws	white
F4	25A fuse	C21-F	Connector	gr	grey
K1	Fan relay	Gr	Fan controller	vi	violet
PWM GW	Pulse width modulator	C1	Fan controller connector	or	orange
PWM GW settings:		KSG	A/C control unit		
Duty cycle: 37%		C2	Connector of KSG		
Frequency: 400Hz					
Voltage: 3.6V				X	Cutting point
Function: Low side					Wiring colours may vary.

Legend

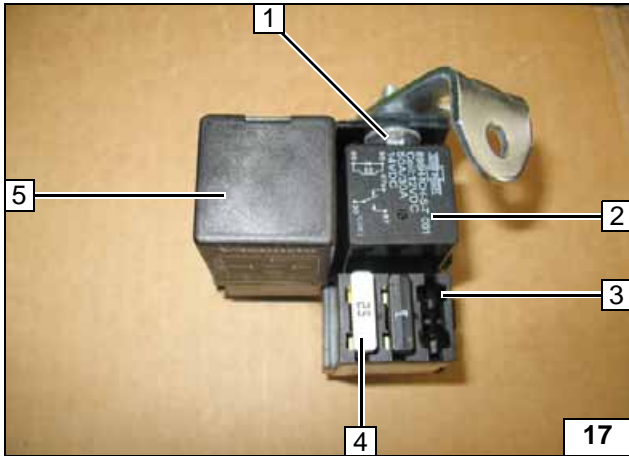
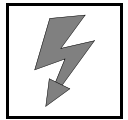

Produce all following electrical connections as shown in the wiring diagram.

- 1 M5x16 bolt, large diameter washer, passenger compartment relay and fuse holder, angle bracket, large diameter washer, nut
- 2 Relay K1
- 3 Passenger compartment relay and fuse holder
- 4 25A fuse F4
- 5 PWM GW

Premounting passenger compartment relay and fuse holder

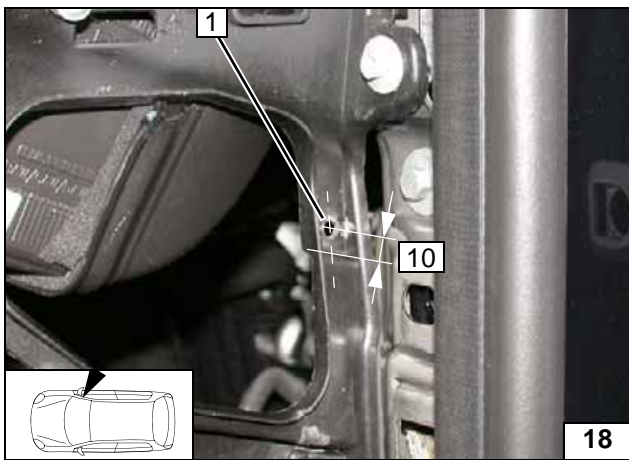

- 1 6.5 mm dia. hole

Hole for passenger compartment relay and fuse holder



- 1 M6x20 bolt, pre-mounted angle bracket, flanged nut

Installing passenger compartment relay and fuse holder

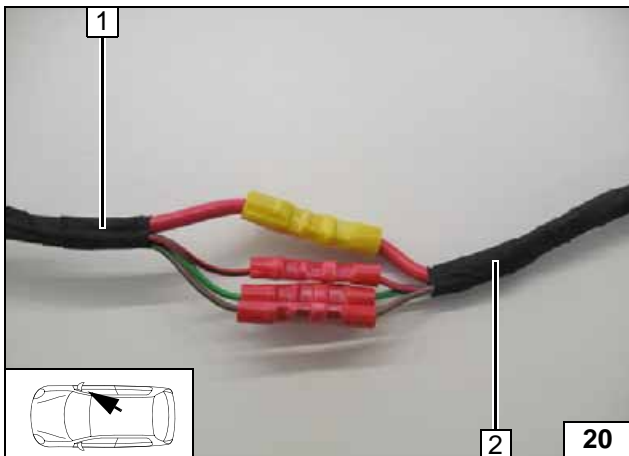

- 1 Passenger compartment relay and fuse holder wiring harness
- 2 Heater wiring harness

Connecting same colour wires of wiring harnesses

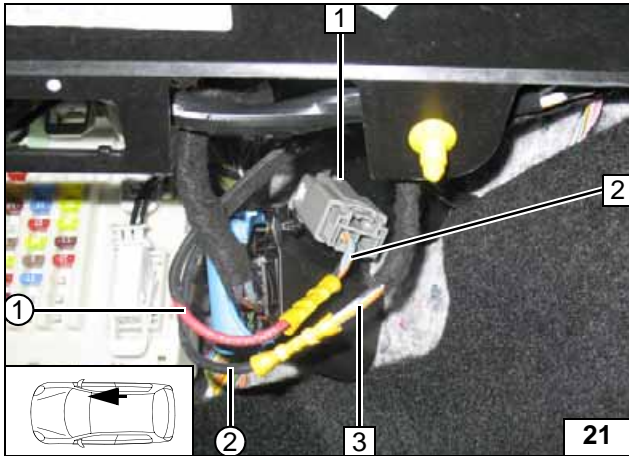
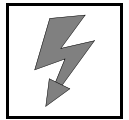

- 1 Connector C21-F
- 2 Grey/orange (gr/or) wire of connector C21-F/ pin 1
- 3 Grey/orange (gr/or) wire from connector C1/ pin 4 of fan controller
- ① Red (rt) wire of K1/87a, fan wiring harness
- ② Black (sw) wire of K1/30, fan wiring harness

**Connect-
ing fan con-
troller**

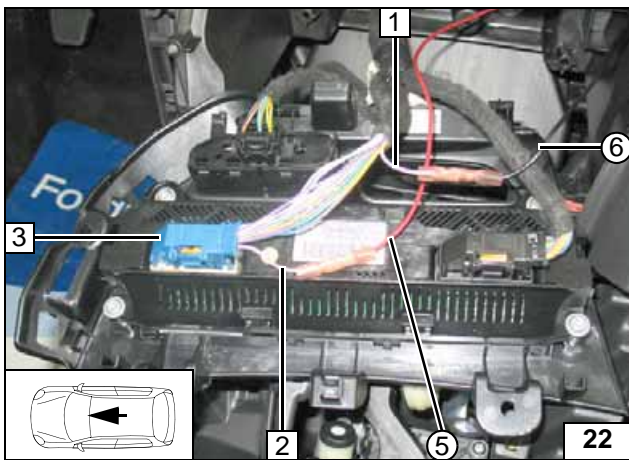

- 1 White/violet (ws/vi) wire from connector C1/ pin 3 of fan controller
- 2 White/violet (ws/vi) wire from connector C2/ pin 15 of A/C control unit
- 3 Connector C2 of A/C control unit
- ⑤ Red (rt) wire from PWM GW/ IN of PWM control wiring harness
- ⑥ Black (sw) wire from PWM GW/ OUT of PWM control wiring harness

**Connect-
ing A/C
control unit**

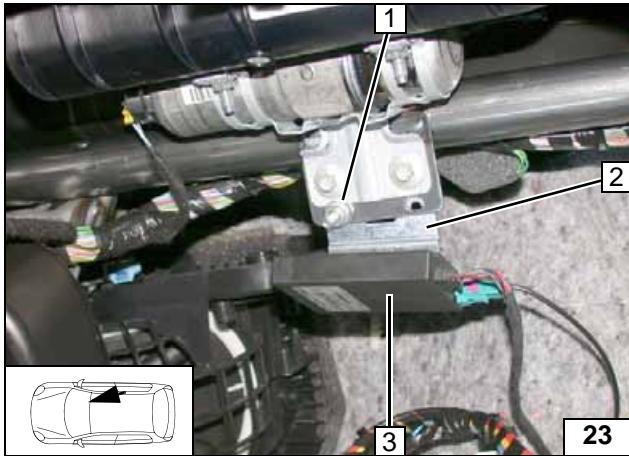
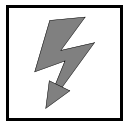

Remote Option (Telestart)

Angle down bracket of receiver 2 as shown.

- 1 M6x20 bolt, flanged nut, existing hole
- 3 Receiver

Installing receiver

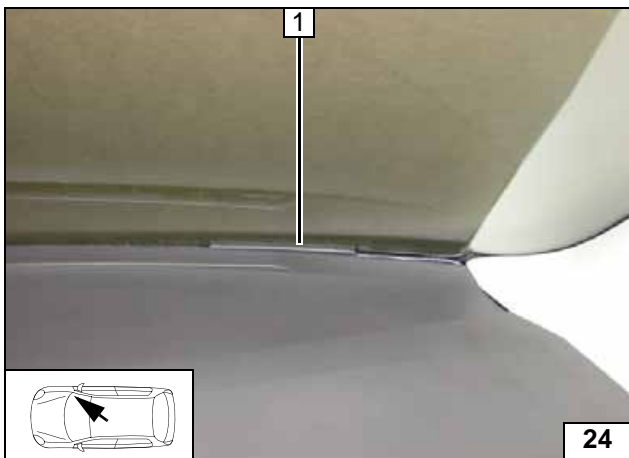

- 1 Aerial

Installing aerial

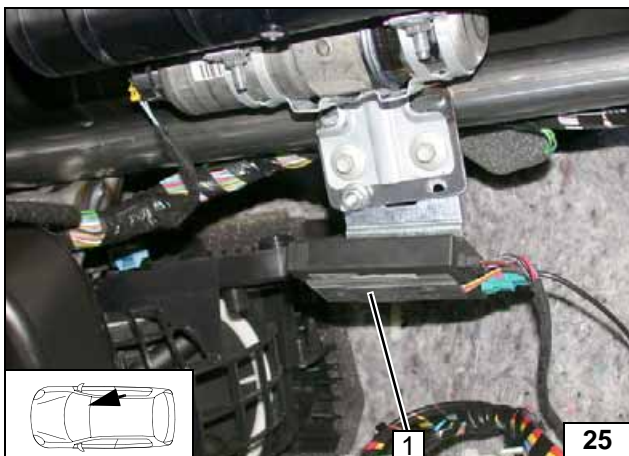

Temperature sensor T100 HTM

Fasten temperature sensor 1 with double-sided adhesive tape.



Installing temperature sensor

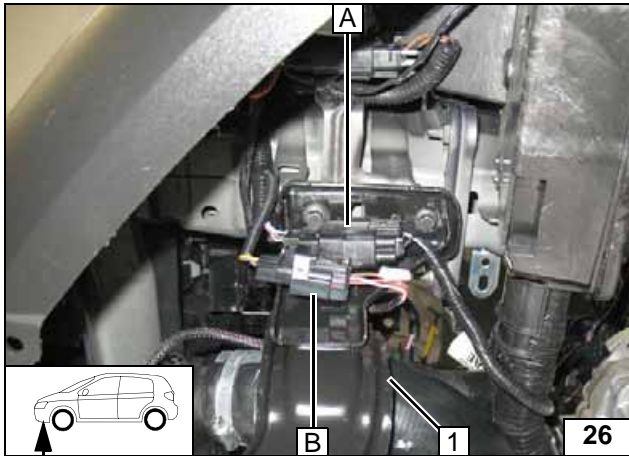

Preparing Installation Location

Dismantle connector **A** and **B** and route behind cross member **1**.



Removing connector

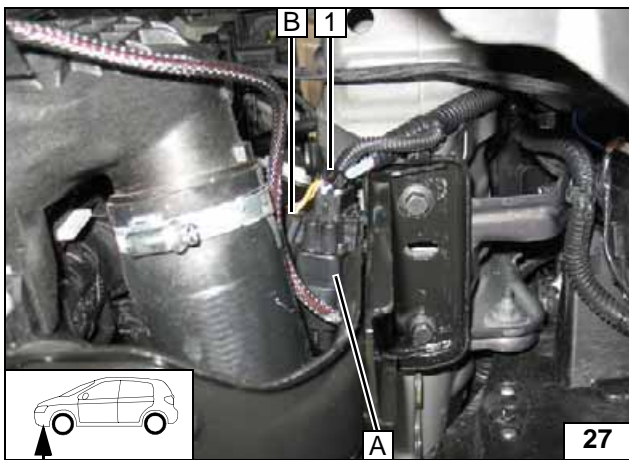

Insert connector **A** in the existing holes. Fasten connector **B** to connector **A** using cable tie **1**.



Mounting connector

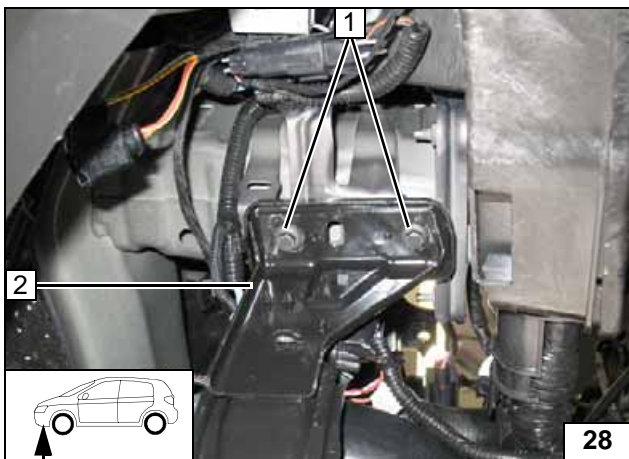

Dismantle original vehicle bolt **1** [2x]. Support cross member **2** with suitable resources. The bolts will be reused.



Dismantling bolts

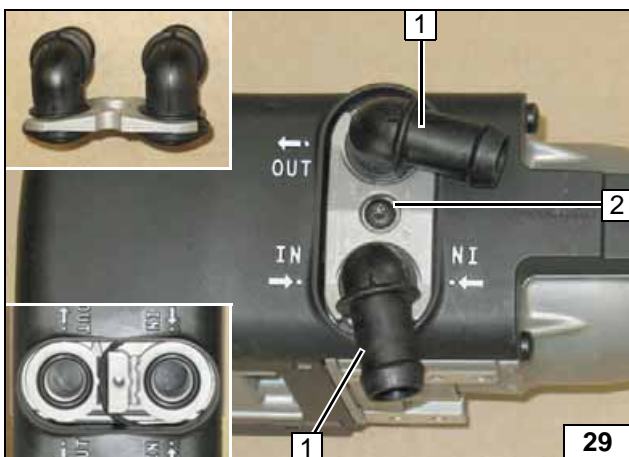

Preparing Heater

- 1 Water connection piece, sealing ring [2x each]
- 2 5x15 self-tapping bolt, retaining plate of water connection piece



Installing water connection piece

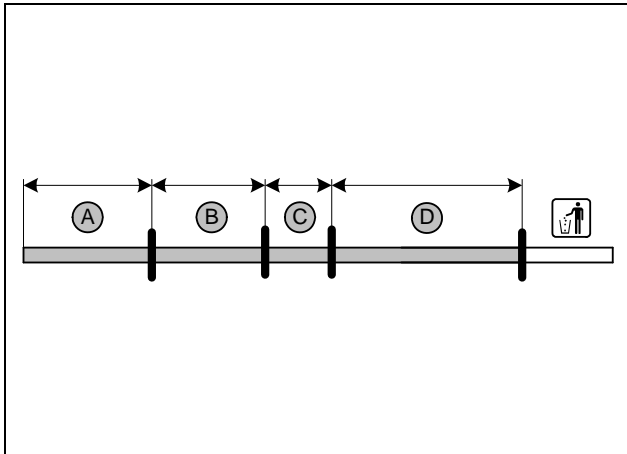

- A = 440
- B = 270
- C = 60
- D = 720

Cutting hose to length

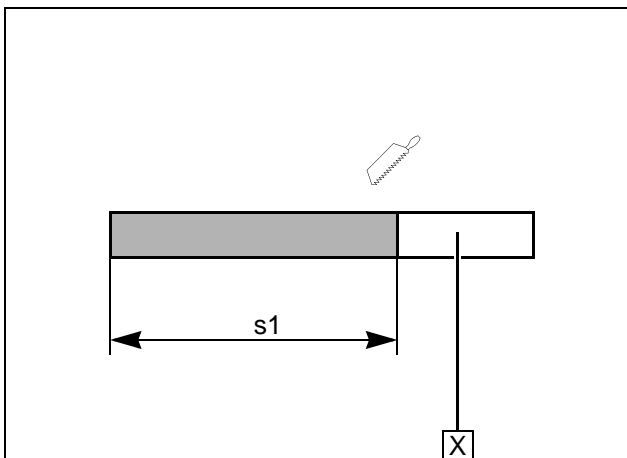

s1 = 640

X =

Cutting combustion air pipe to length

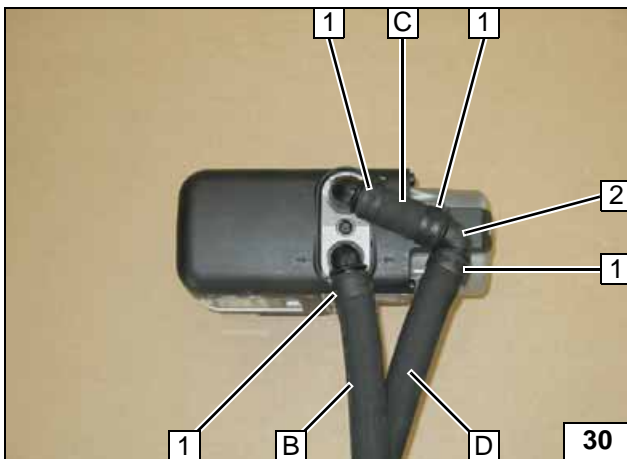

- 1 25 mm dia. spring clip [4x]
- 2 90° 18x18 connecting pipe

Mounting coolant hoses

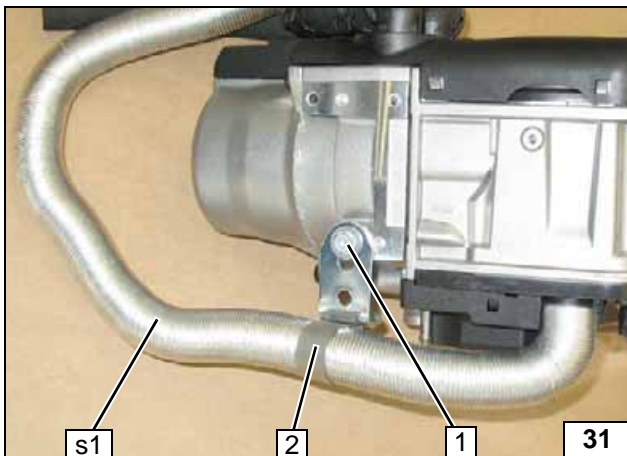

- 1 Self-tapping bolt, large diameter washer, angle bracket
- 2 P-clamp, M6x20 bolt, flanged nut



Installing combustion air pipe s1

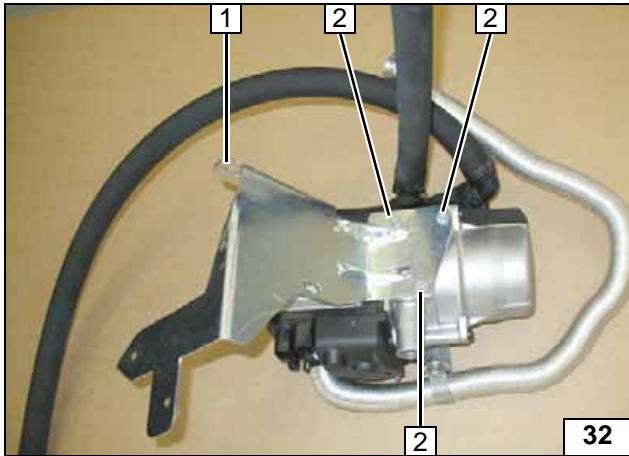

- 1 Bracket
- 2 5x13 self-tapping bolt [3x]

Installing bracket

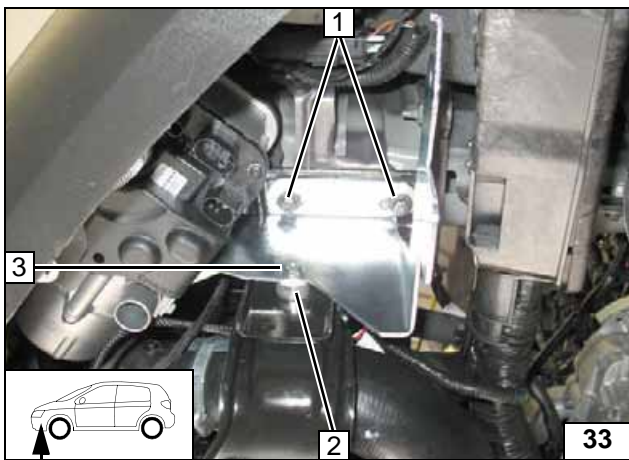

Installing Heater

- 1 Original vehicle bolt [2x]
- 2 10 mm spacer
- 3 M6x25 bolt, existing hole, flanged nut

Installing heater

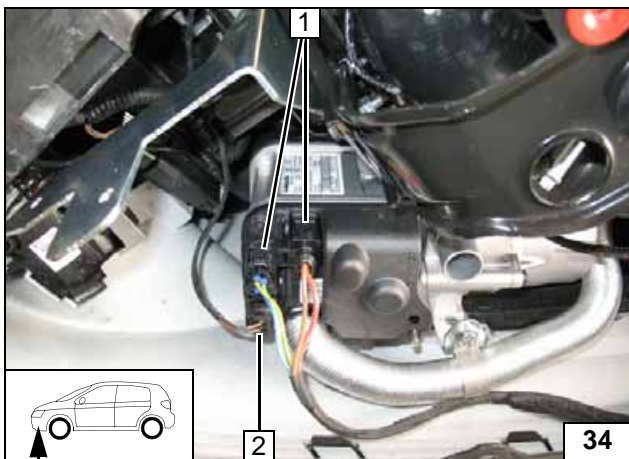

- 1 Heater wiring harness connector [2x]
- 2 Connector of circulating pump wiring harness

Mounting wiring harnesses



Coolant Circuit



WARNING!

Any coolant running off should be collected in an appropriate container. Route hoses kink-free. Unless specified otherwise, always fasten using cable ties. Position clamps so that other hoses cannot be damaged. The heater must be filled with coolant when installing the hoses.

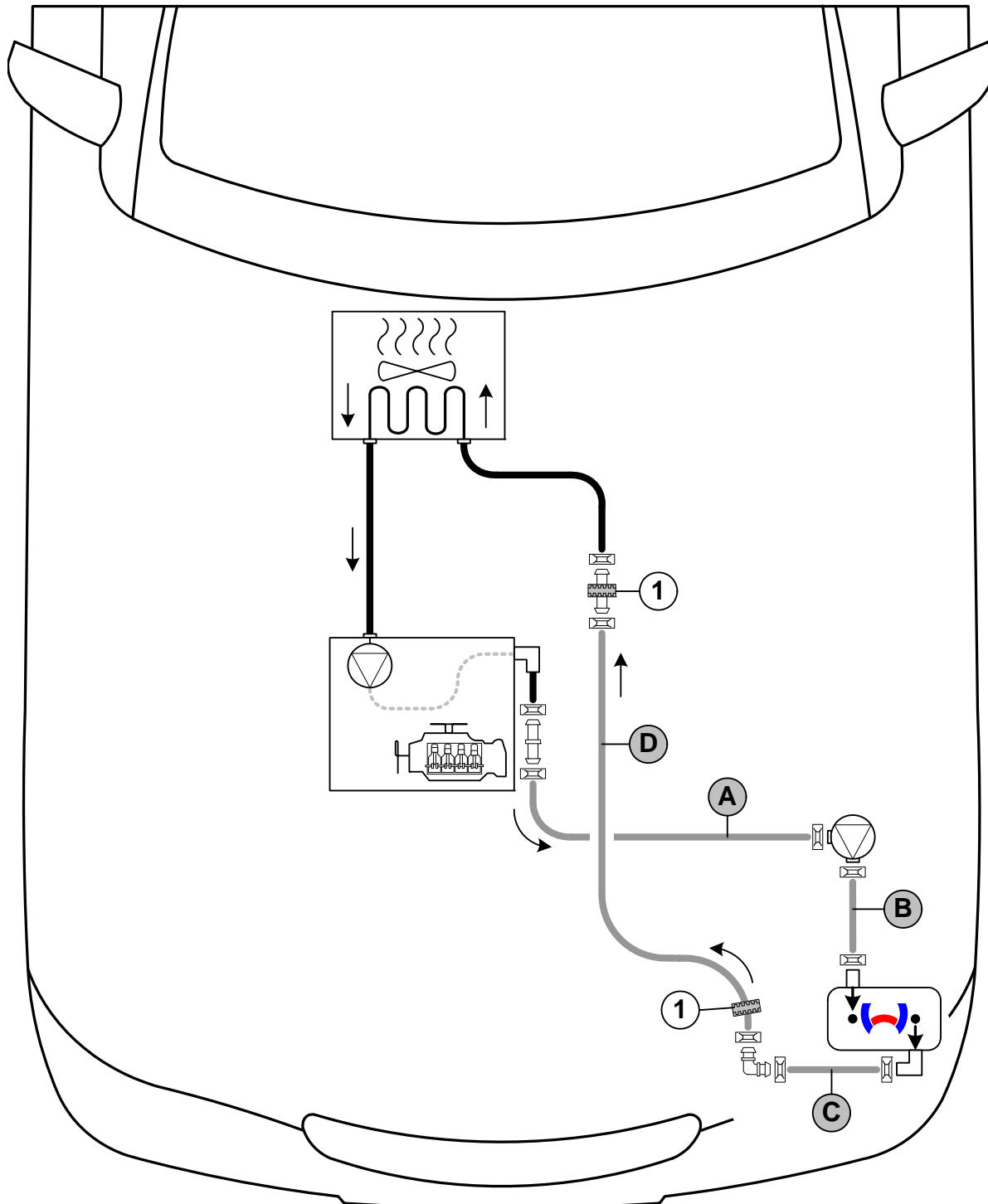
The connection should be modelled on an 'inline' circuit and based on the following diagram:
The displayed coolant circuit is meant primarily for passenger compartment heating.



Hose routing diagram

All spring clips =  25 mm dia.
All connecting pipes  and  = 18x18mm dia.



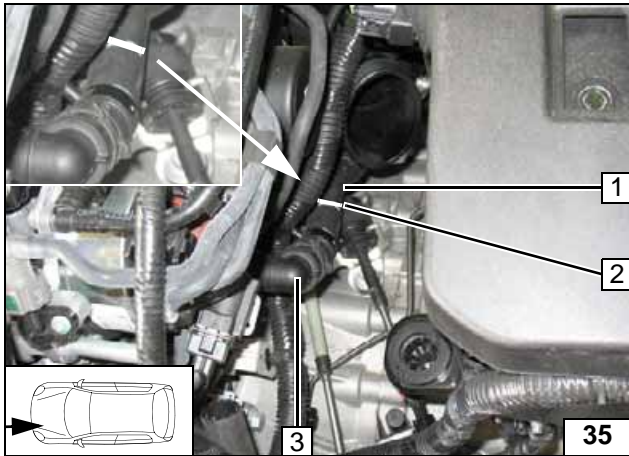

- 1 Heat exchanger inlet hose section
- 2 Cutting point
- 3 Engine outlet

Cutting point

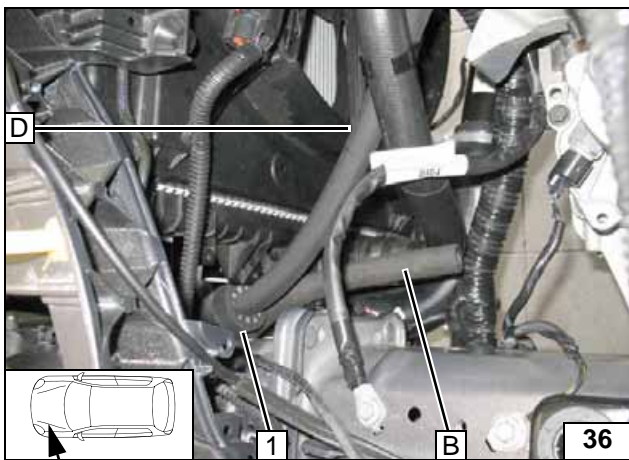

- 1 Black (sw) rubber isolator

Routing hose D

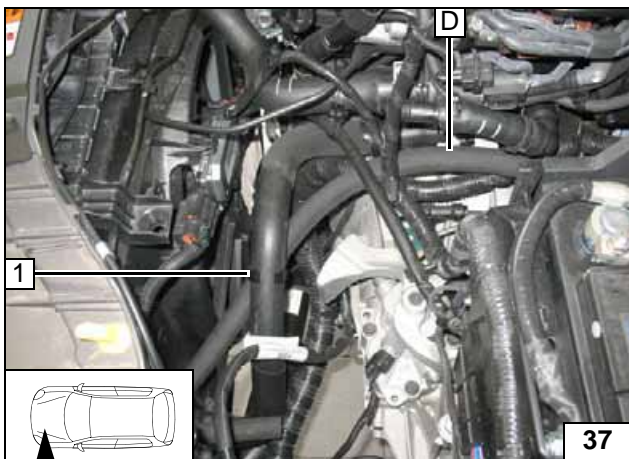

- 1 Hose bracket

Routing hose D

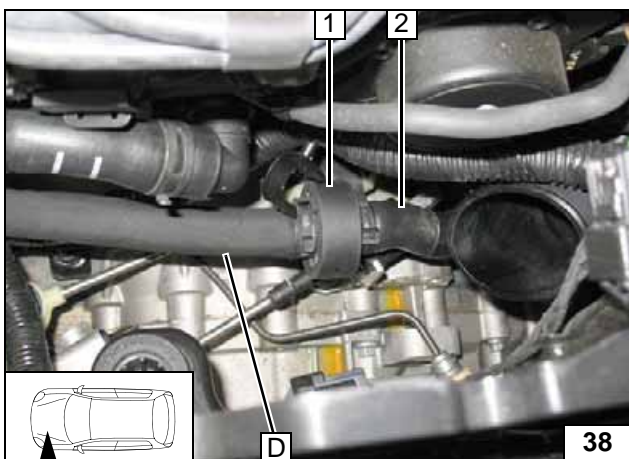

- 1 Black (sw) rubber isolator
- 2 Heat exchanger inlet hose section

Connecting heat exchanger inlet

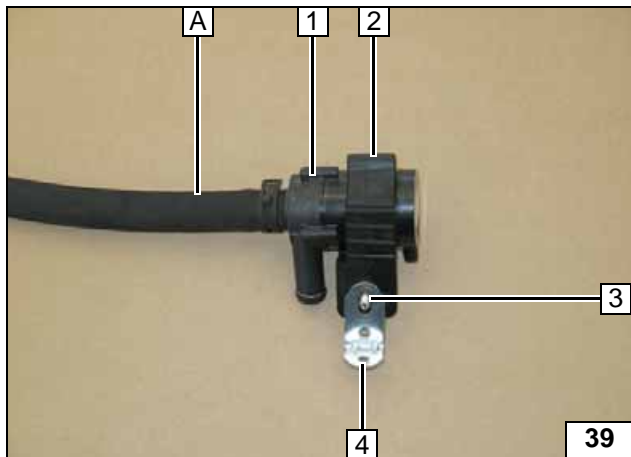

- 1 Circulating pump
- 2 Circulating pump bracket
- 3 M6x25 bolt, tubular rivet, pin lock
- 4 Angle bracket

Premounting circulating pump

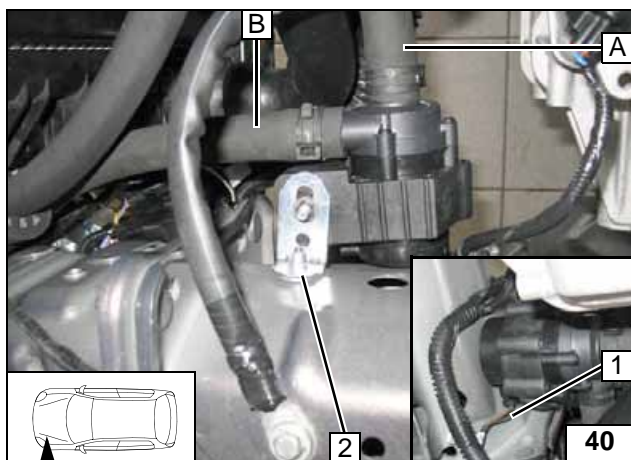

- 1 Connector of circulating pump wiring harness
- 2 Plate nut, existing stud bolt

Mounting circulating pump

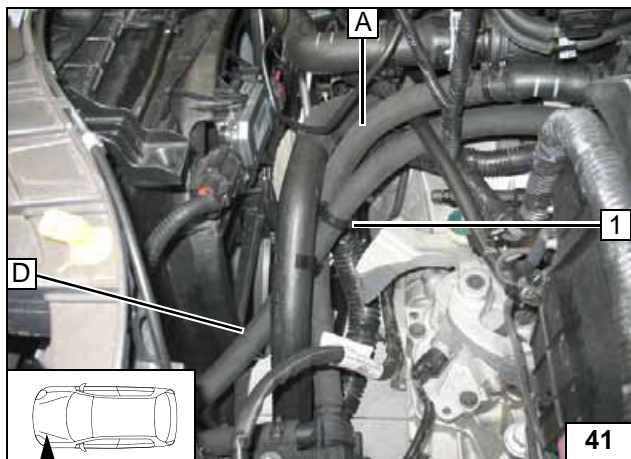

- 1 Hose bracket

Routing hose A

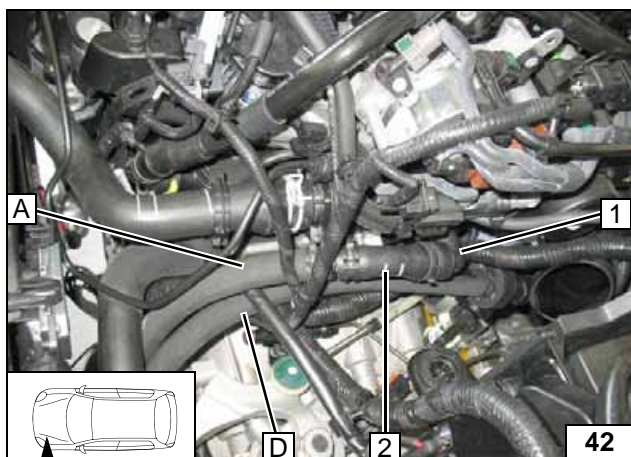

Align hoses. Ensure sufficient distance from neighbouring components, correct if necessary.

- 1 Connection of engine outlet twisted by approx. 180°
- 2 Engine outlet hose section

Connecting engine outlet



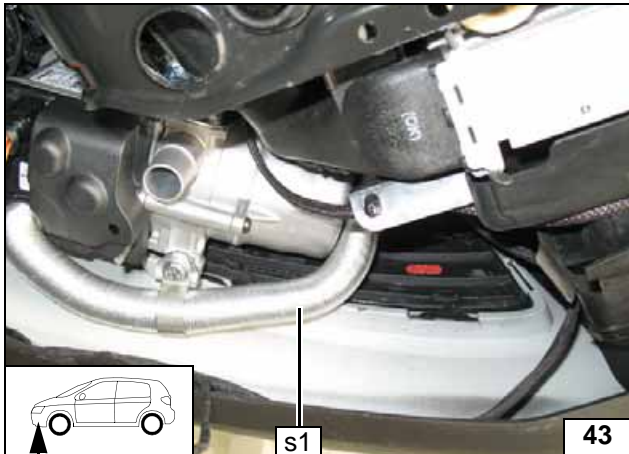
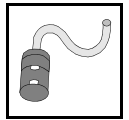

Combustion Air

Route combustion air pipe 1 to installation location of circulating pump.



Routing combustion air pipe s1

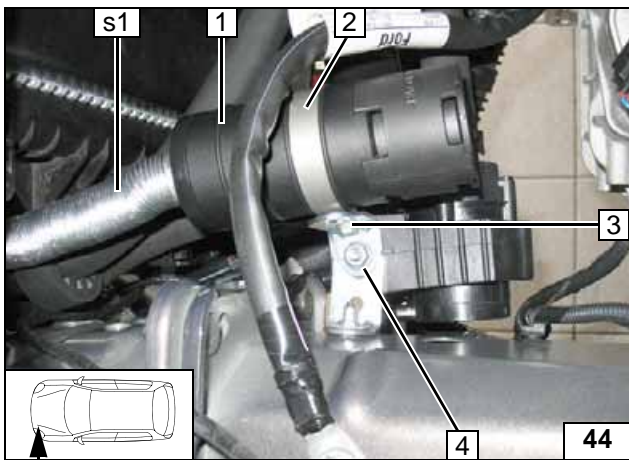

- 1 Silencer
- 2 51 mm dia. clamp
- 3 Angle bracket, M5x16 bolt, flanged nut
- 4 Flanged nut



Installing silencer

Ford Focus

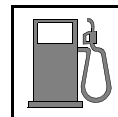

Fuel

CAUTION!

Open the vehicle's fuel tank cap, ventilate the tank and then re-close the tank lock.

Catch any fuel running off in an appropriate container.

Route fuel line and metering pump wiring harness so that they are protected against stone impact. Unless specified otherwise, always fasten using cable ties.

Provide rub protection for fuel line and wiring harness in areas where there are sharp edges.

WARNING!

The fuel line and wiring harness are routed to the metering pump as shown in the wiring harness routing diagram.

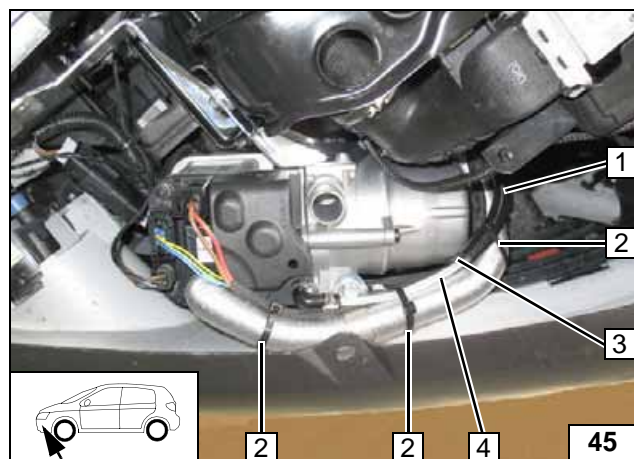

Draw wiring harness of metering pump **3** and fuel line **4** into corrugated tube **1**, route to fire-wall along original vehicle fuel lines to the underbody.

2 Cable tie [3x]

Connecting heater

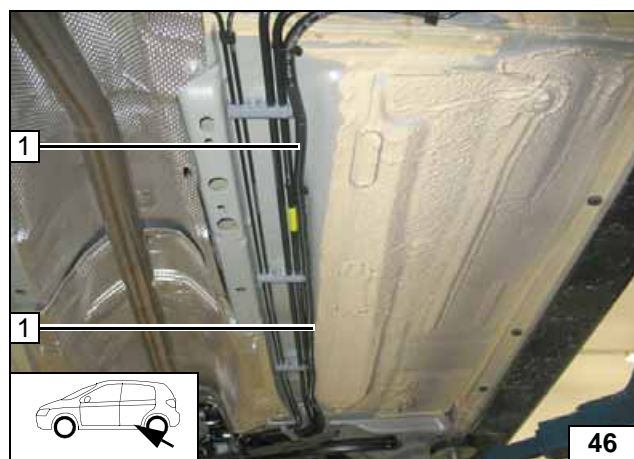

1 Fuel line and metering pump wiring harness in corrugated tube

Routing lines

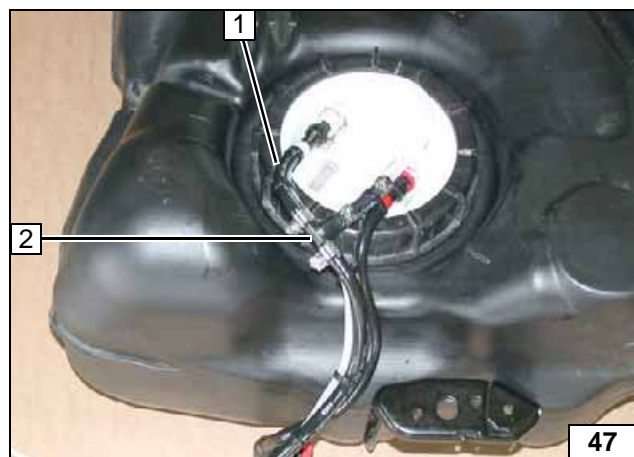

Remove the fuel tank according to the manufacturer's instructions. Cut off fuel supply line **1** at position **2**.



Fuel extraction

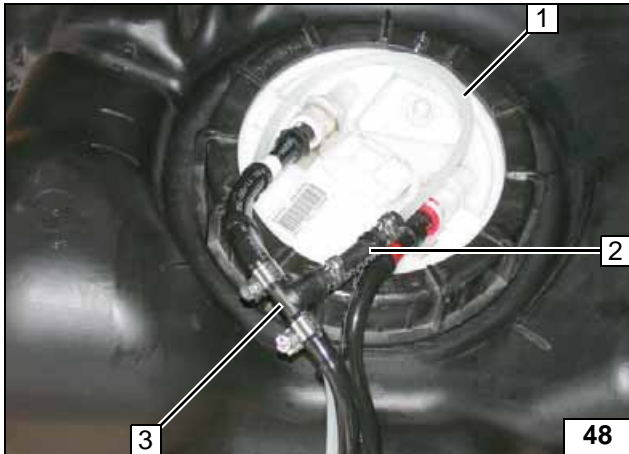
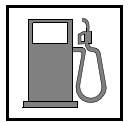

- 1 Fuel line
- 2 Hose section, 10mm dia. clamp [2x]
- 3 8x5x8 fuel standpipe, 10 mm dia.hose clamp [2x]



Installing fuel standpipe

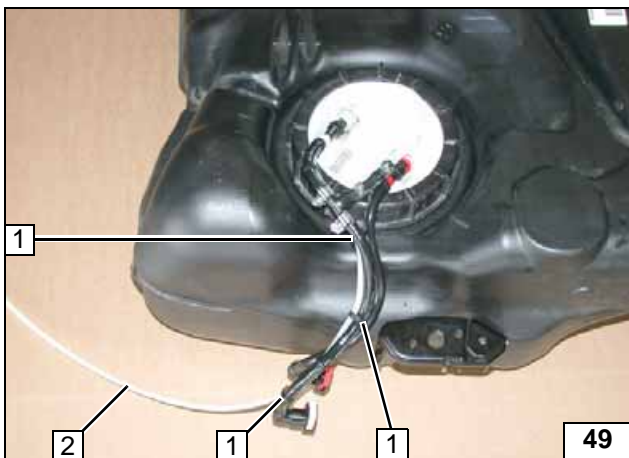

Fasten fuel line 2 with cable tie 1. Install fuel tank in accordance with manufacturer's instructions.



Mounting fuel line

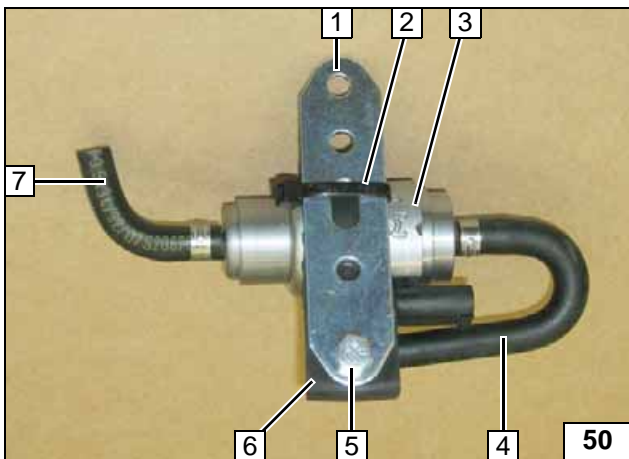

- 1 Perforated bracket
- 2 Cable tie
- 3 Metering pump
- 4 180° moulded hose, 10 mm dia. clamp
- 5 M6x25 bolt, support angle bracket, flanged nut
- 6 Metering pump mount
- 7 90° moulded hose, 10 mm dia. clamp

Premounting metering pump

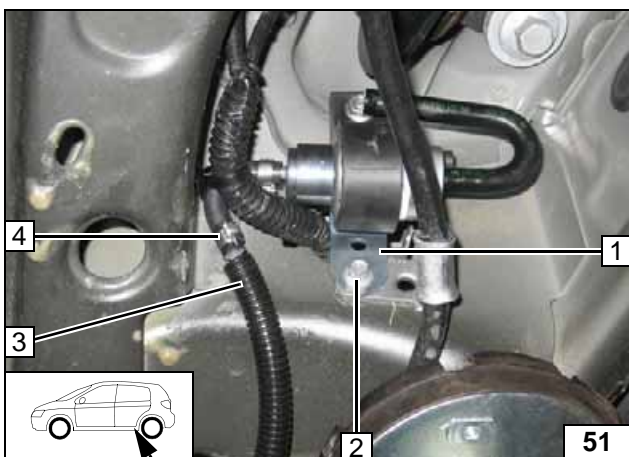

- 1 Perforated bracket
- 2 Original vehicle bolt
- 3 Fuel line of fuel standpipe in corrugated tube
- 4 10 mm dia. clamp



Installing metering pump

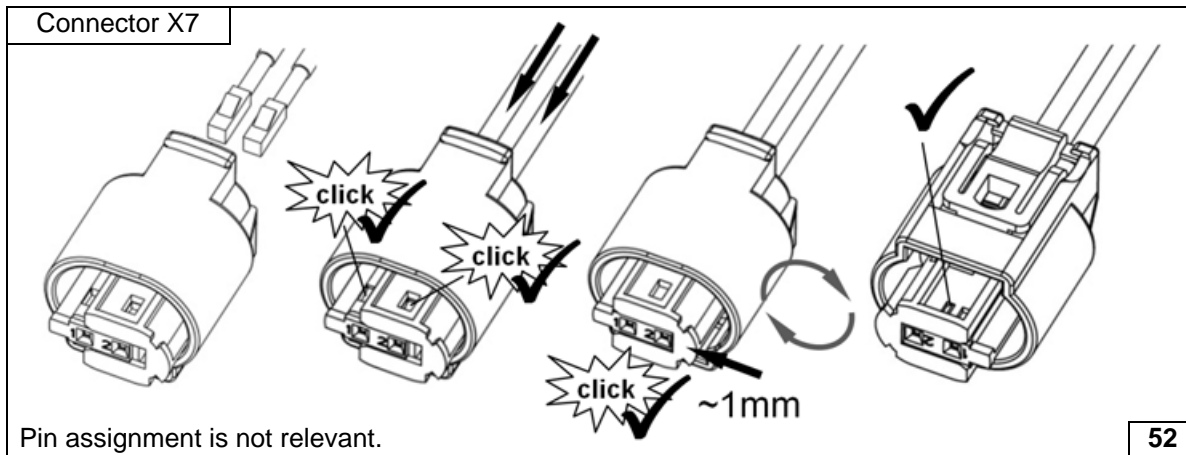
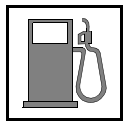

Completing metering pump connector

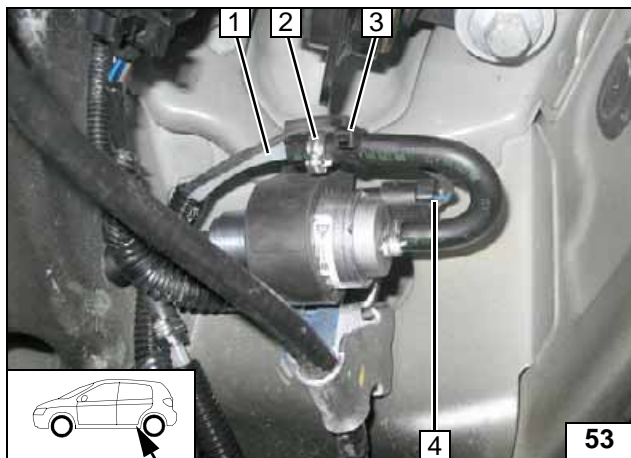

Check the position of the components; adjust if necessary. Check that they have freedom of movement.



- 1 Heater fuel line
- 2 10 mm dia. clamp
- 3 Cable tie
- 4 Metering pump wiring harness, connector X7 mounted

Connecting metering pump

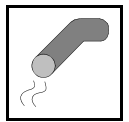

Exhaust Gas

a1 = 160
a2 = 260

X =

**Preparing ex-
haust pipe**

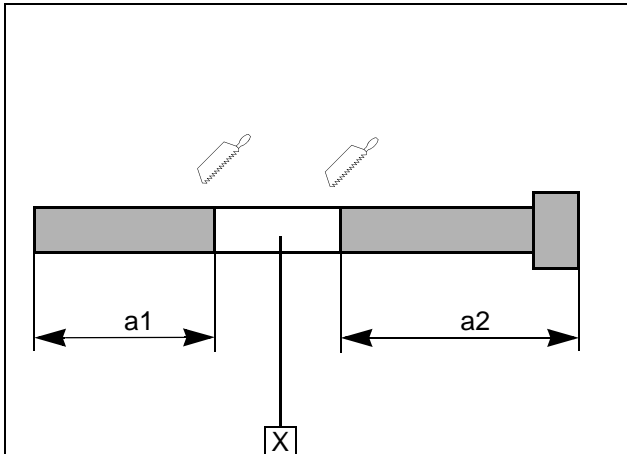

- 1 Exhaust silencer
- 2 M6x15 bolt, spring lockwasher

**Installing
silencer**

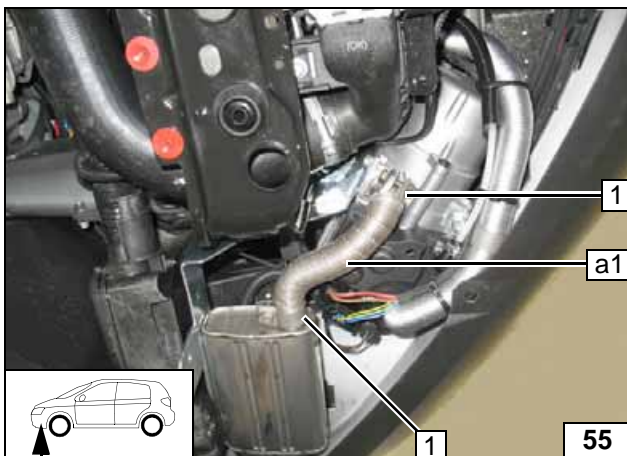

- 1 Hose clamp [2x]

**Attaching
exhaust
pipe a1**

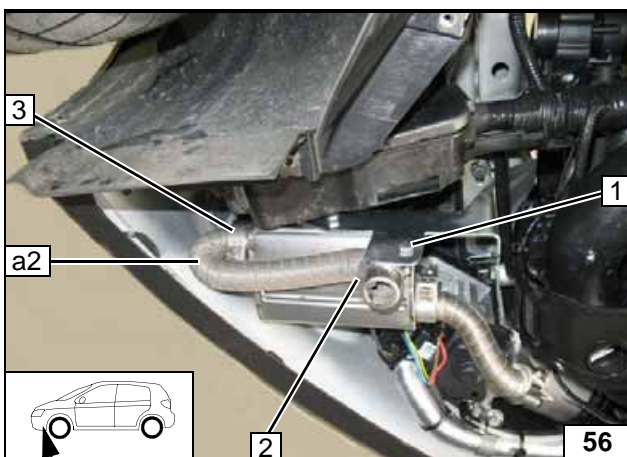

- 1 M6x20 bolt, flanged nut
- 2 P-clamp
- 3 Hose clamp

**Attaching
exhaust
pipe a2**

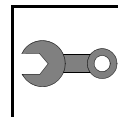

Final Work

WARNING!

Reassemble the components in reverse order. Check all hoses, clamps and all electrical connections for firm seating. Insulate and tie back loose lines. Only use manufacturer-approved coolant. Spray the heater components with anti-corrosion wax (Tectyl 100K).



- **Connect the battery.**
- **Fill and bleed the coolant circuit according to the vehicle manufacturer's instructions.**
- **Program MultiControl CAR, teach Telestart transmitter.**
- **Make settings on the A/C control panel according to the 'operating instructions'.**
- **Place the 'Switch off parking heater before refuelling' caution label near the filler neck.**
- **For initial startup and function check, please see installation instructions.**

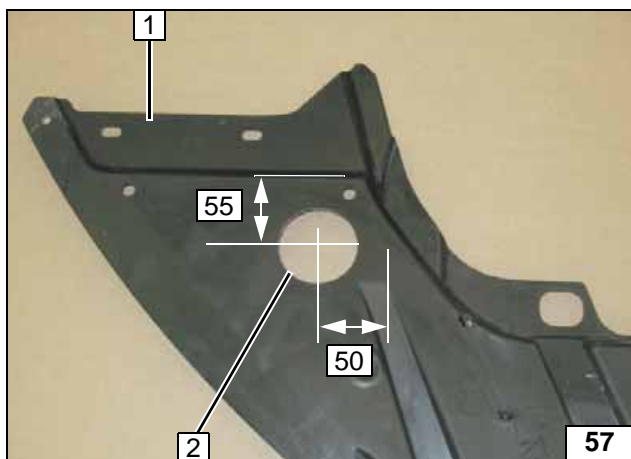

- 1 Underride protection
- 2 60 mm dia. hole

Cutting out
underride
protection

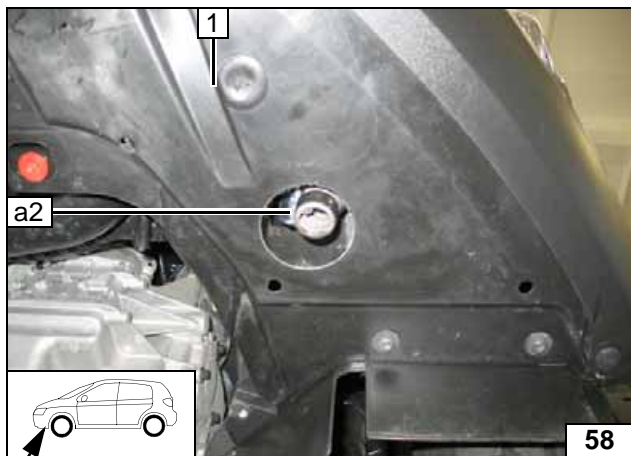

Install underride protection 1.
Align exhaust pipe a2 flush with underride protection 1. Ensure sufficient distance from neighbouring components.



Aligning
exhaust
pipe a2

Webasto Thermo & Comfort SE
Postfach 1410
82199 Gilching
Germany
Internet: www.webasto.com
Technical Extranet:
<http://dealers.webasto.com>

Operating Instructions for Manual A/C

Please remove page and add to the vehicle operating instructions.

Note:

We recommend matching the heating time to the driving time.
Heating time = driving time

Example:

For a driving time of approx. 20 min. (in one direction), we recommend not exceeding a switch-on time of 20 min.

Passenger compartment monitoring, if installed, must be deactivated in addition to the vehicle settings for the heating operation.

For instructions on deactivation, please refer to the operating instructions of the vehicle.

Before parking the vehicle, make the following settings:

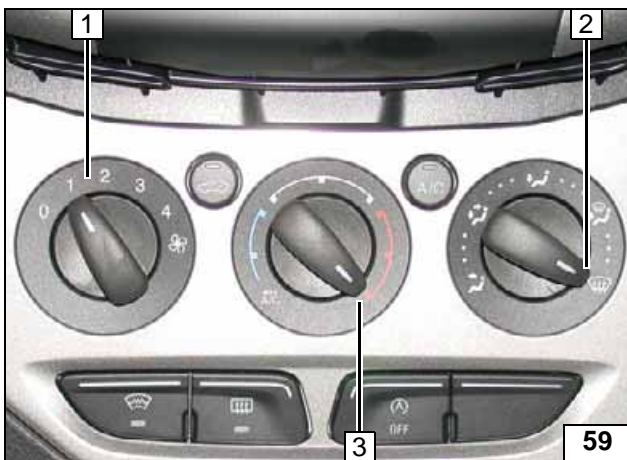

- 1 Set fan to level '1', or max. '2'
- 2 Air outlet to windscreen
- 3 Set temperature to 'max.'



A/C control panel

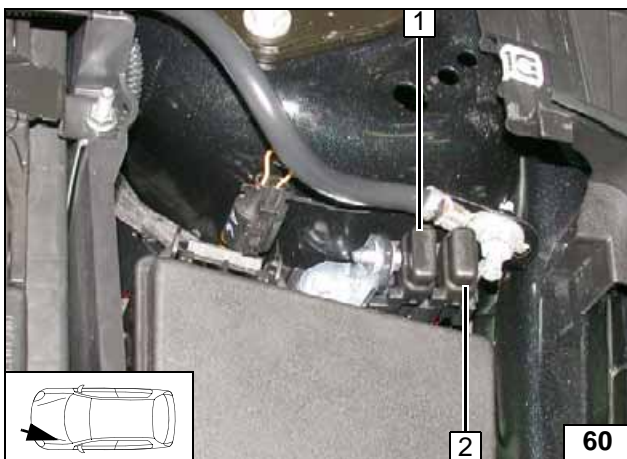

- 1 30A passenger compartment main fuse F2
- 2 20A heater fuse F1

Engine compartment fuses

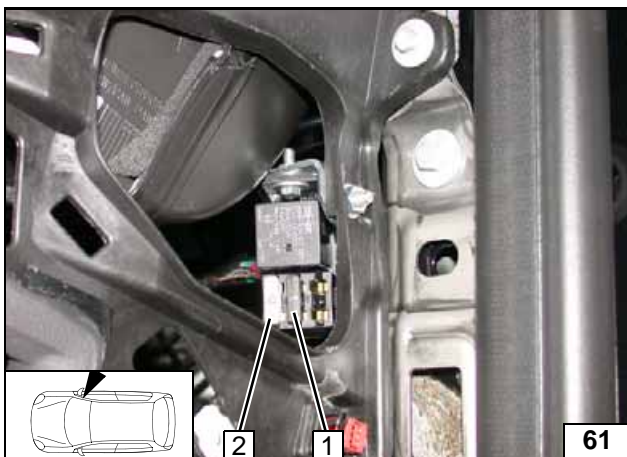

- 1 1A heater control fuse F3
- 2 25A fan fuse F4

Passenger compartment fuses



Operating Instructions for Automatic A/C

Please remove page and add to the vehicle operating instructions.

Note:

We recommend matching the heating time to the driving time.
Heating time = driving time

Example:

For a driving time of approx. 20 min. (in one direction), we recommend not exceeding a switch-on time of 20 min.

Passenger compartment monitoring, if installed, must be deactivated in addition to the vehicle settings for the heating operation.

For instructions on deactivation, please refer to the operating instructions of the vehicle.

Before parking the vehicle, make the following settings:



Fan speed need not be pre-set.

- 1 Set temperature to "HI"
- 2 Air outlet to windscreen



A/C control panel

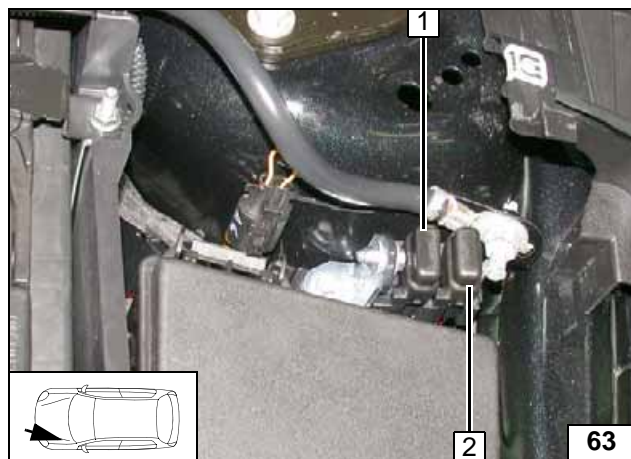

- 1 30A passenger compartment main fuse F2
- 2 20A heater fuse F1

Engine compartment fuses

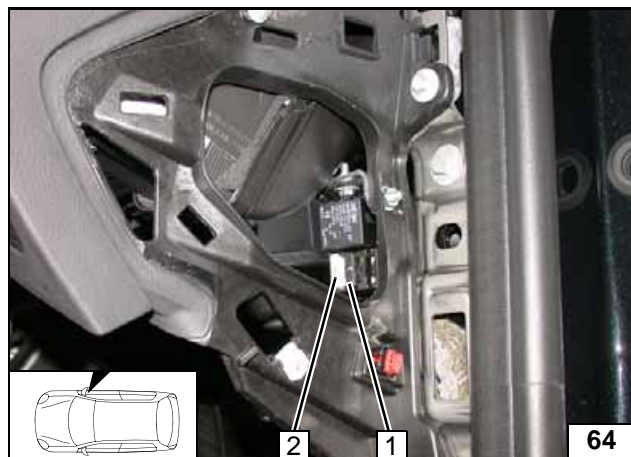

- 1 1A heater control fuse F3
- 2 25A fan fuse F4

Passenger compartment fuses

