

Water Heater



Thermo Top Evo Parking Heater

e1

00 0258

Installation documentation

VW Golf / Golf Plus / Jetta

1.4 TSI and 1.6 TDI

from model year 2011

Left-hand drive vehicle

Manual transmission

Climatic / Climatronic

Passenger compartment monitoring not checked!



WARNING!

Hazard warning:

The improper installation or repair of Webasto heating and cooling systems can cause fire or the leakage of deadly carbon monoxide, leading to serious injury or death.



To install and repair Webasto heating and cooling systems you need to have completed a special company training course and have the appropriate technical documentation, special tools and special equipment.

Only use genuine Webasto parts. See the Webasto air and water heaters accessories catalogue for this purpose.

NEVER attempt to install or repair Webasto heating or cooling systems if you have not successfully completed the company training and thereby acquired the required technical skills, or if you do not have access to the required technical documentation, tools and equipment needed to carry out correct installation and repairs.

ALWAYS follow all Webasto installation and repair instructions and observe all warnings.

The initial startup is to be executed with the Webasto Thermo Test Diagnosis.

Webasto does not accept any liability for defects and damage that are attributable to installation by untrained staff.

Table of Contents

Validity	2	Preparing Installation Location	17
Heater / Installation Kit	3	Preparing Heater	18
Foreword	3	Installing Heater	22
General Instructions	3	Coolant Circuit 1.4 TSI 90kW	23
Special Tools	3	Coolant Circuit 1.4 TSI 118kW	27
Explanatory Notes on Document	4	Coolant Circuit 1.6 TDI	31
Preliminary Work	5	Fuel	35
Heater Installation Location	5	Wheel-Well Inner Panel / Underride Protection	39
Preparing Electrical System	6	Final Work	40
Electrical System	9	Template for Fuel Standpipe	41
Climatic Fan Control	10	Operating Instructions for End Customer	42
Climatronic Fan Control	12		
Digital Timer	14		
Remote Option (Telestart)	14		

Validity

Manufacturer	Model	Type	EG BE No. / ABE
VW	Golf	1K	e1 * 2001 / 116 * 0242 * ...
VW	Golf Plus	1KP	e1 * 2001 / 116 * 0304 * ...
VW	Jetta	16	e1 * 2007 / 46 * 0539 * ...

Engine type	Engine model	Output in kW	Displacement in cm ³
CAXA / 6-speed SG	Petrol/TSI	90	1390
CAVD / 6-speed SG	Petrol/TSI	118	1390
CAYC / 5-speed SG	Diesel / TDI	77	1598

Vehicle and engine types, equipment variants and national specifications not listed in this installation documentation have not been tested. However, installation according to this installation documentation may be possible.

The installation location of the digital timer should be confirmed with the end customer before installation.

Heater / Installation Kit

Quantity	Description	Order No.:
1	Basic delivery scope <i>Thermo Top Evo</i>	see price list
1	Installation Kit VW Passat / Jetta / Golf VI Plus / Golf VI TDI and TSI 2011	1317668A
1	Heater control	see price list

Also required with Climatronic

Quantity	Description	Order No.:
1	Automatic air-conditioning kit	1317273A

Foreword

This installation documentation applies to VW Golf / Golf Plus / Jetta 1.4 TSI and 1.6 TDI vehicles - for validity, see page 2 - from model year 2011 and later, assuming technical modifications to the vehicle do not affect installation, any liability claims excluded. Depending on the vehicle version and equipment, modifications may be necessary during installation with respect to the installation documentation.

However, the stipulations in this "installation documentation", the "operating instructions" and the "installation instructions" for the *Thermo Top Evo* must always be observed.

The corresponding rules of technology and any information from the vehicle manufacturer should be observed during the installation work.

General Instructions

Installation should be carried out according to the general, standard rules of technology. Unless specified otherwise, fasten hoses, lines and wiring harnesses to original vehicle lines and wiring harnesses using cable ties. Insulate loose wires and tie back.

Sharp edges should be fitted with rub protection (split-open fuel hose).

Spray unfinished body areas, e.g. drilled holes, with anti-corrosion wax (Tectyl 100K, Order No. 111329).

When installing an IPCU, check or adjust the corresponding settings before installation.

Special Tools

- Torque wrench for 2.0 - 10 Nm
- Hose clamping pliers
- Centre bit 60mm dia.

Explanatory Notes on Document

You will find an identification mark on the outside top right corner of the page in question to provide you with a quick overview of the individual working steps.

Mechanical system

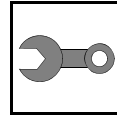

Electrical system

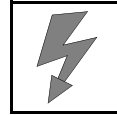

Coolant circuit

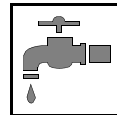

Fuel

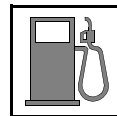

Exhaust gas

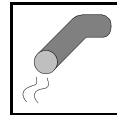

Combustion air

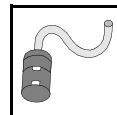

Software

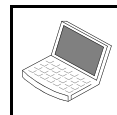

Special features are highlighted using the following symbols:



Specific risk of injury or fatal accidents.



Specific risk of damage to components.



Specific risk of fire or explosion.



Reference to general installation instructions of Webasto components or to the manufacturer's vehicle-specific documents.



Reference to a special technical feature.

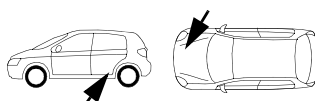

The arrow in the vehicle icon indicates the position on the vehicle and the viewing angle.

All dimensions are in mm!

Tightening torque of 5x13 heater bolts = 8Nm!

Tightening torque of 5x15 bolt of water connection piece retaining plate = 7Nm!

Preliminary Work

WARNING!

- Open the fuel tank cap, ventilate the tank.
- Close the fuel tank cap again.
- Disconnect the battery earth connection.
- Depressurise the cooling system.
- Copy the factory number from the original type label to the duplicate type label.
- Remove years that do not apply from the duplicate label.
- Attach the duplicate label (type label) in the appropriate place.
- Completely remove the battery.
- Remove the battery carrier.
- Remove the air filter completely.
- Remove charge-air hose and pipe.
- Remove the underride protection.
- Remove the wheel-well inner panel.
- Fold up the rear bench seat.
- Open the right-hand tank-fitting service lid.
- Remove the fuel-tank sending unit in accordance with manufacturer's instructions.
- Remove the side trim of A-pillar on the driver's side.
- Remove the driver/front passenger side footwell trim.
- Remove the instrument panel trim at the left.

Remove page 42 "Operating Instructions for End Customer" and add to the vehicle operating instructions.

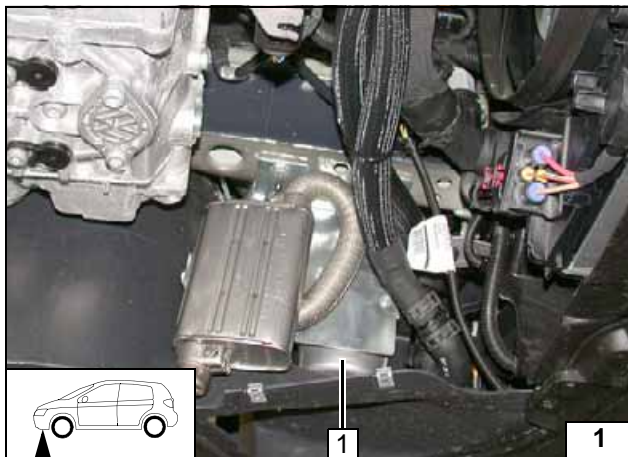

Heater Installation Location

Image shows 1.4 TSI

1 Heater



Installation location

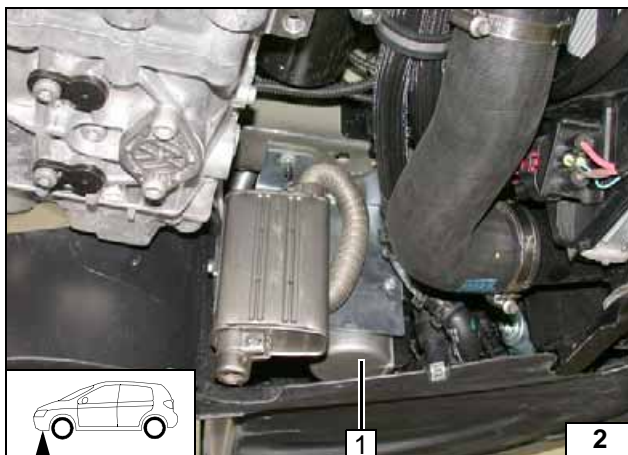
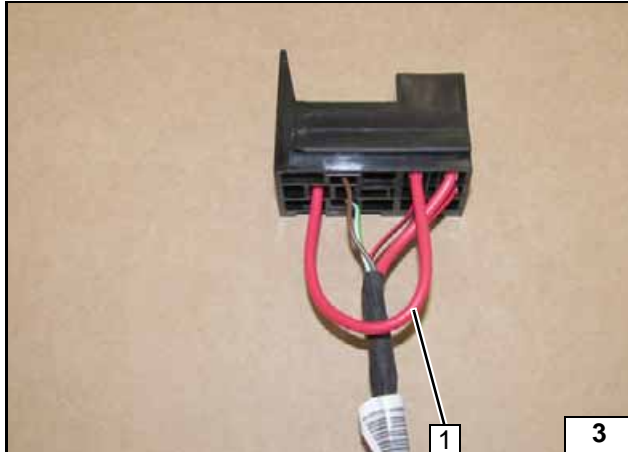

Image shows 1.6 TDI

1 Heater



Installation location



Preparing Electrical System

Climatronic

Wire sections retain their numbering in the entire document.

Detach red (rt) wire 1 from fuse F4 and discard.



Removing wire

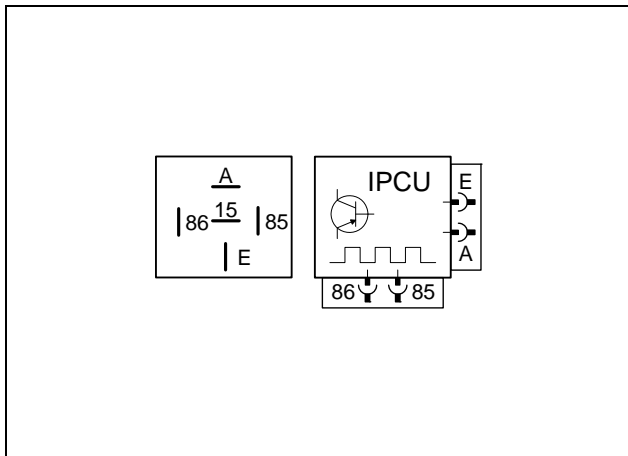

IPCUC view on contact side.
The IPCUC provided in the kit is pre-programmed with the following settings.

- Duty cycle: 30%
- Frequency: 400Hz
- Voltage: 8V
- Function: High side

The adjustment values must be checked during the function check of the vehicle and adjusted, if necessary.



Preparing IPCUC

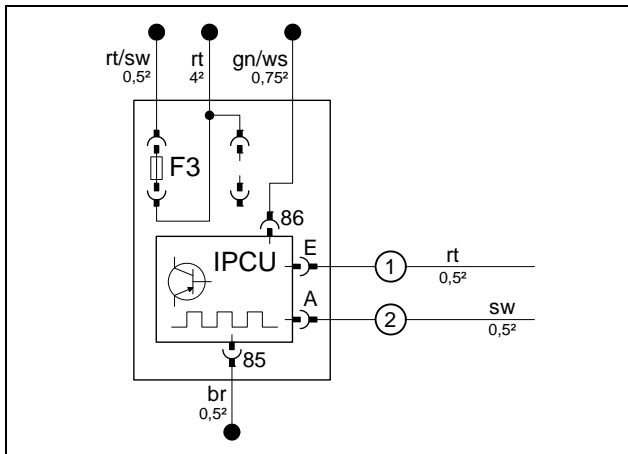

IPCUC is to be inserted only after fuse holder has been pre-mounted. Connect wires to socket IPCUC. Draw wire ① and ② into the protective sleeving.

- ① Red (rt) wire of IPCUC/E
- ② Black (sw) wire of IPCUC/A



Preparing IPCUC

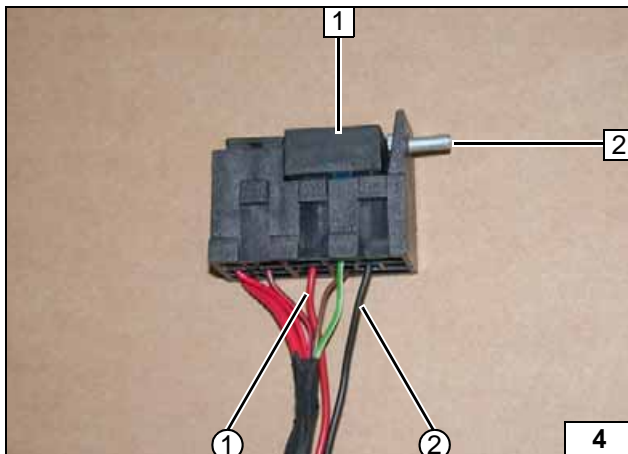

Golf / Jetta

- 1 IPCUC
- 2 M5x16 bolt, large diameter washer, retaining plate of fuse holder

- ① Red (rt) wire of IPCUC/E
- ② Black (sw) wire of IPCUC/A

Pre-mounting passenger compartment fuse holder

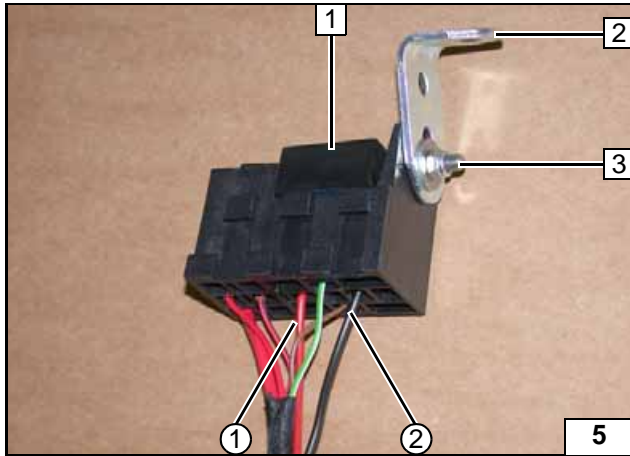

Golf Plus

- 1 IPCU
- 2 Angle bracket
- 3 M5x16 bolt, large diameter washer [2x], retaining plate of fuse holder, self-locking M5 flanged nut

- ① Red (rt) wire of IPCU/E
- ② Black (sw) wire of IPCU/A



Premounting passenger compartment fuse holder

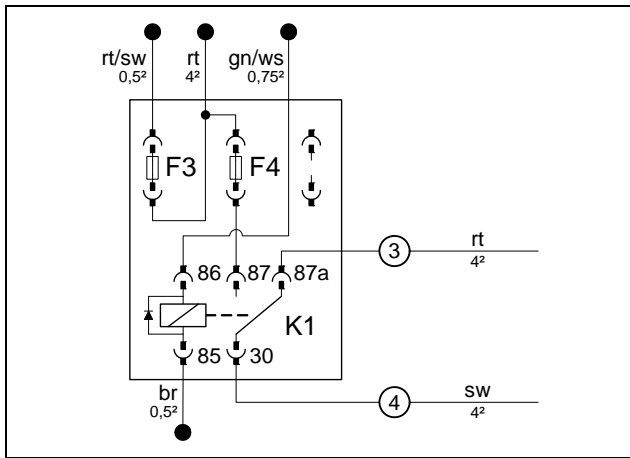

Climatic

Wire sections retain their numbering in the entire document.



Premounting fuse holder of passenger compartment

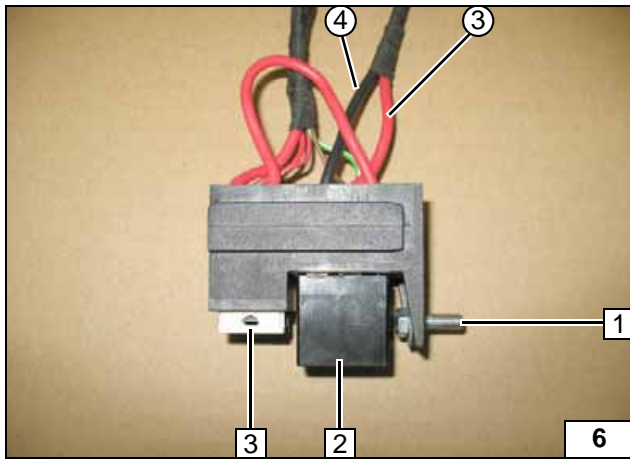

Golf / Jetta

- 1 M5x16 bolt, large diameter washer, fuse holder
- 2 K1 relay
- 3 Fuse F4 25A

- ③ Red (rt) wire of K1/87a
- ④ Black (sw) wire of K1/30

Premounting passenger compartment fuse holder

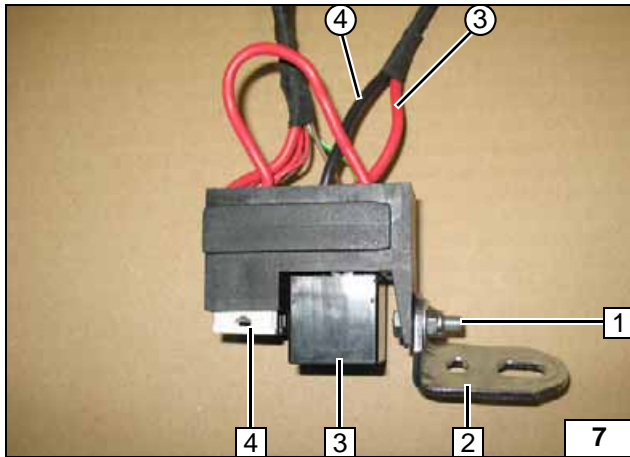

Golf Plus

- 1 M5x16 bolt, large diameter washer [2x], fuse holder, self-retaining nut
- 2 Angle bracket
- 3 K1 relay
- 4 Fuse F4 25A

- ③ Red (rt) wire of K1/87a
- ④ Black (sw) wire of K1/30

Premounting passenger compartment fuse holder

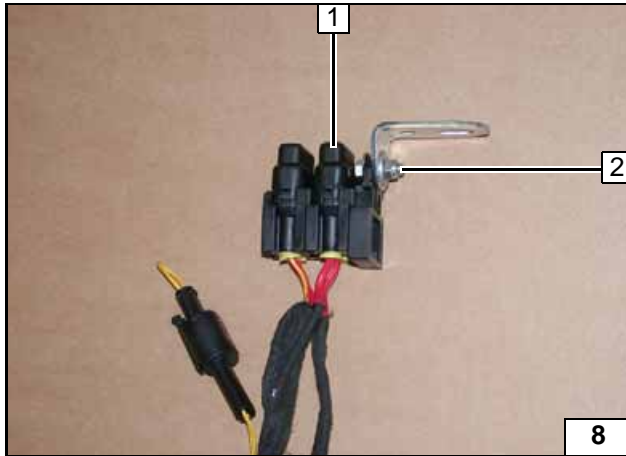

All vehicles

- 1 Fuses F1-2
- 2 M5x16 bolt, large diameter washer, retaining plate of fuse holder, angle bracket, self-locking M5 flanged nut



Premounting the fuse holder of the engine compartment

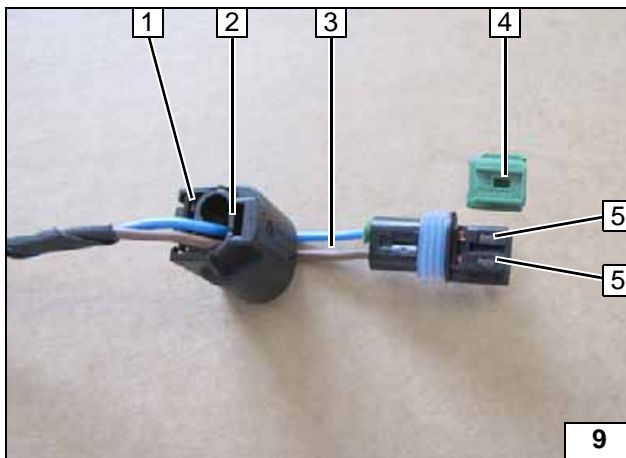

Complete connector of metering pump again after routing. Pin assignment is not relevant.

- 1 Connector housing
- 2 Lock
- 3 Blue / brown (bl / br) wires
- 4 Coding
- 5 Timer lock



Dismantling connector



Electrical System

Positive wire

- 1 Jetta:
Positive wire to positive battery distributor
- 2 Golf, Golf Plus:
Positive wire to positive battery distributor

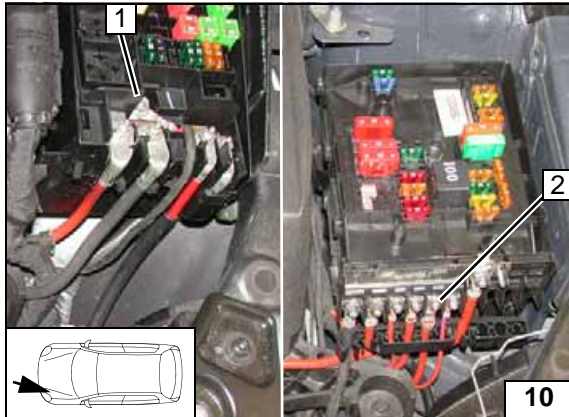

Wiring harness routing, wiring harness pass through

- 1 Use free protective rubber plug
- 2 Wiring harnesses of heater, heater control
- 3 Route wiring harnesses in original vehicle cable duct

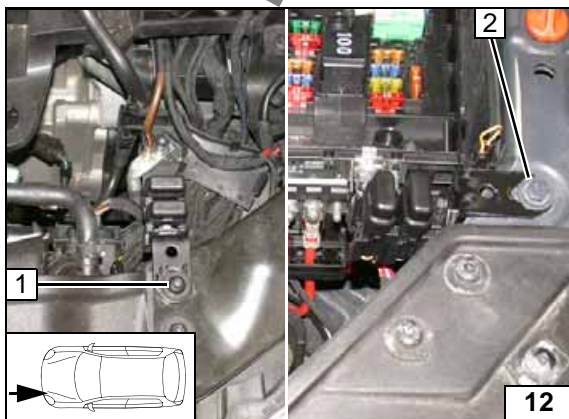
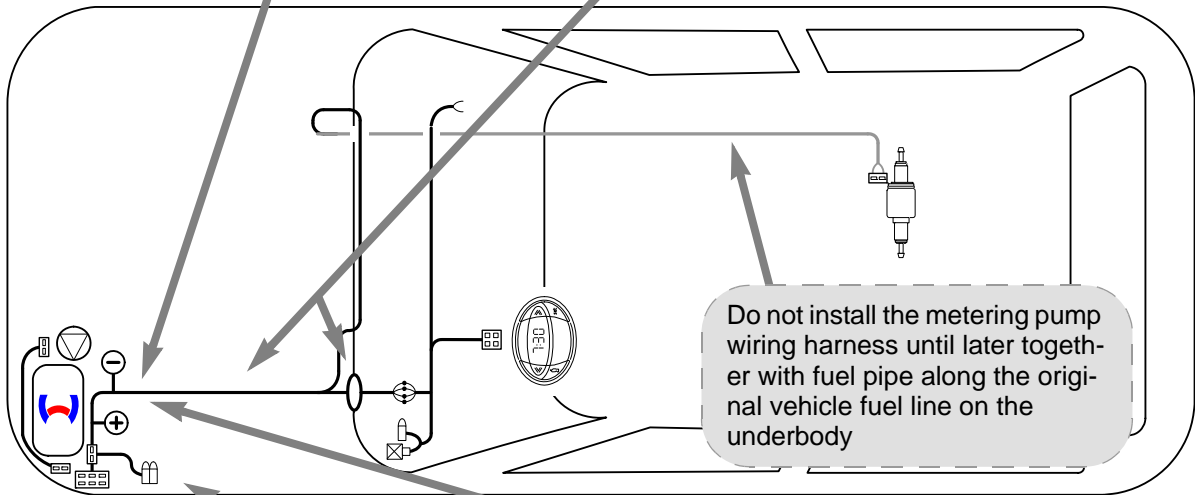
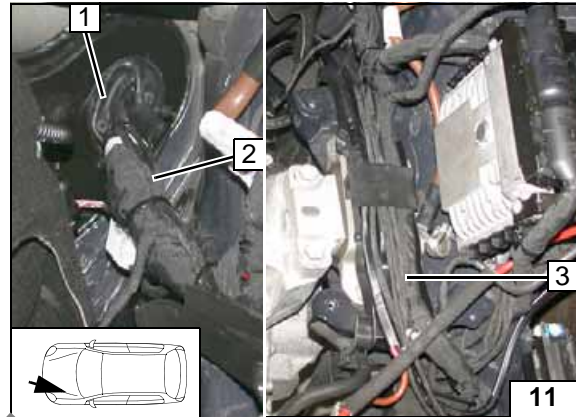

Fuse holder of engine compartment

- 1 Golf, Jetta:
Original vehicle bolt, angle bracket, fuses
- 2 Golf Plus:
Original vehicle bolt, angle bracket, fuses



Earth wire

- 1 Earth on original vehicle earth support point



Wiring harness routing diagram



Climatic Fan Control

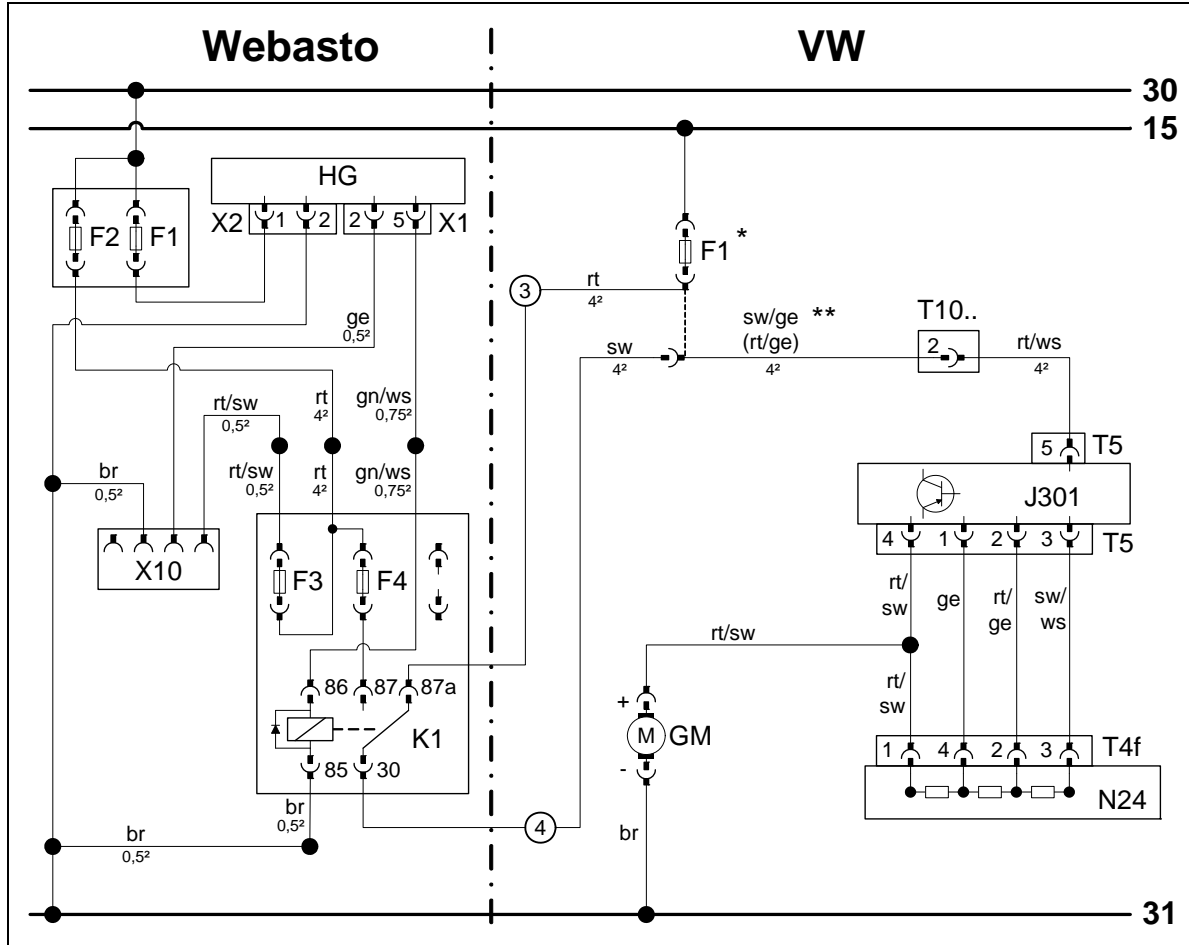

Wiring diagram

Webasto components		Vehicle components		Colours and symbols	
HG	TT-Evo heater	GM	Fan motor	rt	red
X1	6-pin heater connector	F1*	Fuse, 40A fan fuse (assignment depends on vehicle and vehicle equipment variant)	ge	yellow
X2	2-pin heater connector			sw	black
X10	4-pin connector Heater control	J301	Control unit of air conditioning	br	brown
				ws	white
K1	Fan relay	T5	5-pin connector J301	gn	green
F1	20A fuse	N24	Resistor group	** Golf VI = black/yellow (sw/ge), Golf Plus and Jetta = red/yellow (rt/ge)	
F2	30A fuse	T4f	4-pin connector N24	Wiring colours may vary.	
F3	1A fuse	T10..	Connector		
F4	25 A fuse				

Legend

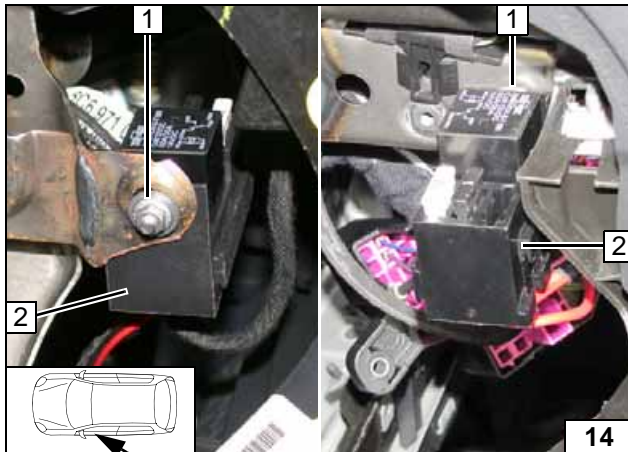

Jetta, Golf

- 1 Existing hole, large diameter washer, self-locking nut
- 2 Fuse holder

Mounting fuse holder in passenger compartment

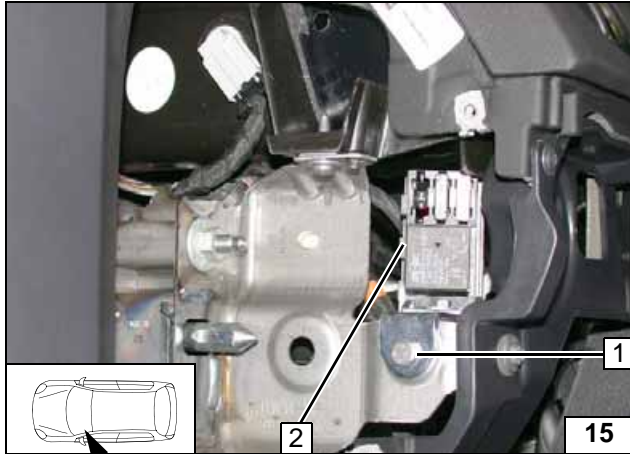

Golf Plus

- 1 M6x20 bolt, angle bracket, existing hole, large diameter washer, M5 self-locking flanged nut
- 2 Fuse holder

Mounting fuse holder in passenger compartment

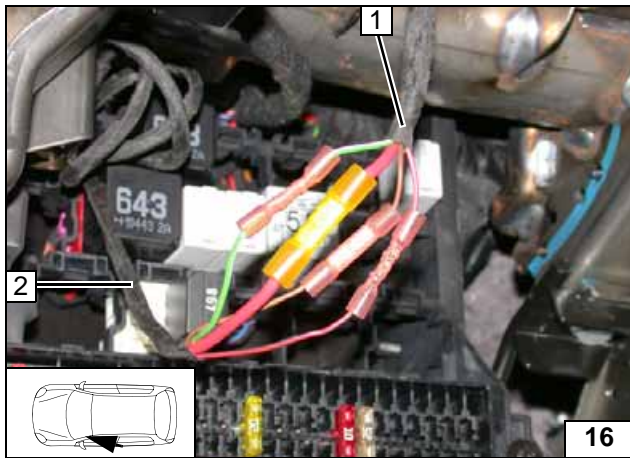

All vehicles

Connect the wiring harness of the fuse holder in passenger compartment 1 to the wiring harness of heater 2 according to the wiring diagram, with same colour wires connected to each other.



Connecting wiring harnesses

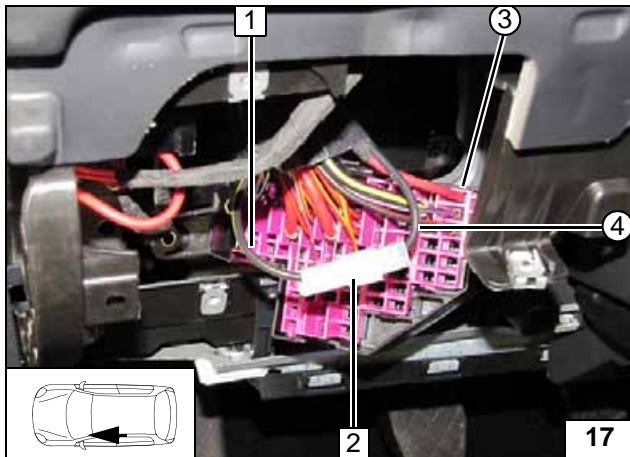

Golf

Fuse socket depends on vehicle equipment. Uncrimp black/yellow (sw/ge) wire 1 from socket of fan fuse. Engage red (rt) wire from K1/87a ③ into socket of fan fuse with crimped on Standard-Power-Timer. Produce connections as shown in wiring diagram.

- 2 Connector
- ④ Black (sw) wire of K1/30



Connecting wires

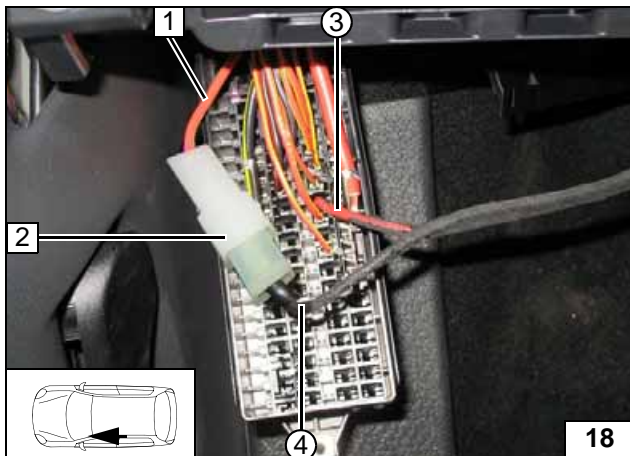

Golf Plus, Jetta

Fuse socket depends on vehicle equipment. Uncrimp red/yellow (rt/ge) wire 1 from socket of fan fuse. Engage red (rt) wire from K1/87a ③ into socket of fan fuse with crimped on Standard-Power-Timer. Produce connections as shown in wiring diagram.

- 2 Connector
- ④ Black (sw) wire of K1/30



Connecting wires



Climatronic Fan Control

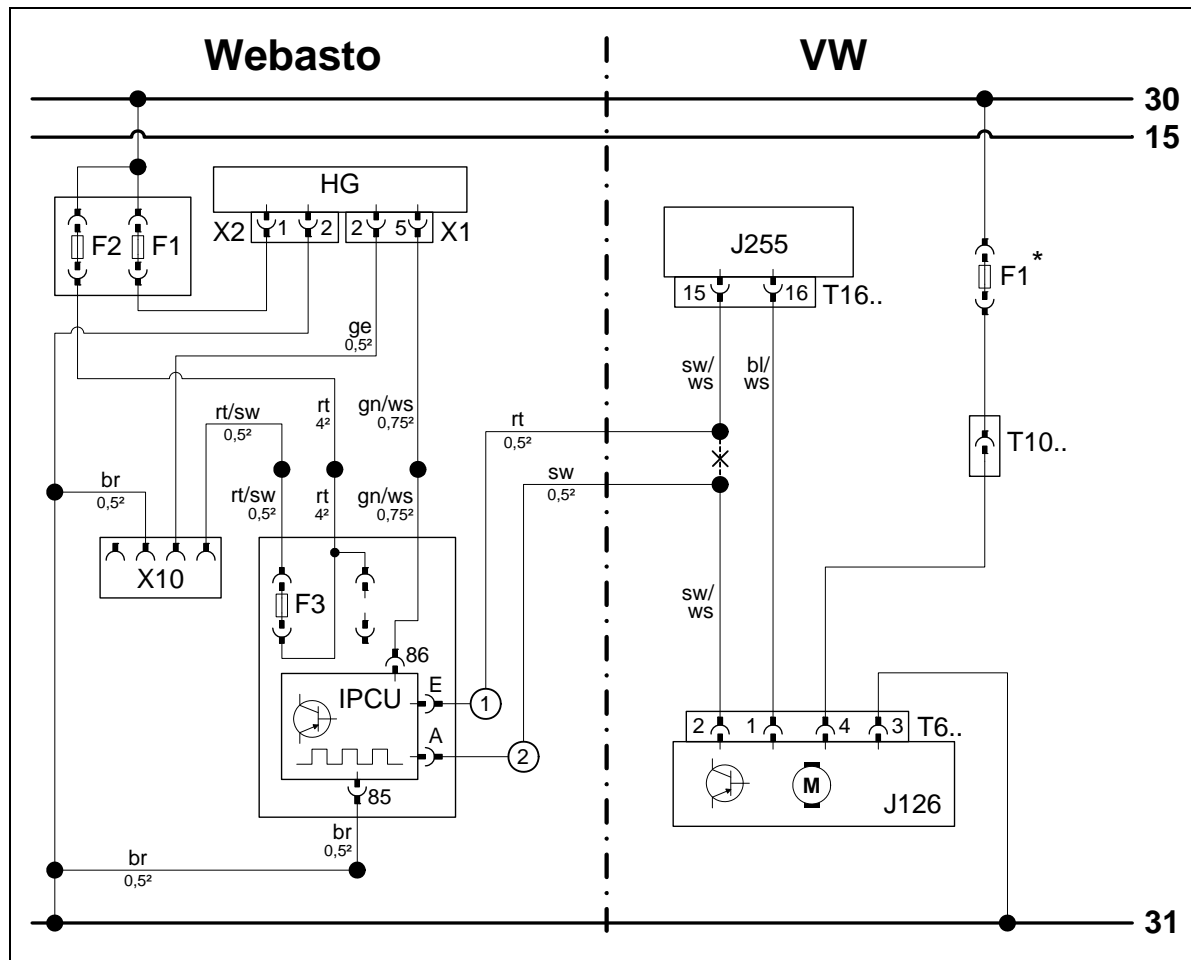

Wiring diagram

Webasto components		Vehicle components		Colours and symbols	
HG	TT-Evo heater	J126	Fan unit	rt	red
X1	6-pin heater connector	T6..	6-pin connector J126	sw	black
X2	2-pin heater connector	J255	A/C control unit	ge	yellow
X10	4-pin connector Heater control	T16..	16-pin connector J255	gn	green
K1	Fan relay	T10..	10-pin connection	bl	blue
F1	20A fuse	F1*	Fuse, 40A fan fuse (assignment depends on vehicle and vehicle equipment variant)	ws	white
F2	30A fuse			br	brown
F3	1A fuse				
IPCU	Pulse width modulator				
IPCU adjustment values:					
Duty cycle: 30%					
Frequency: 400Hz					
Voltage: 8V				X	Cutting point
Function: High side				Wiring colours may vary.	

Legend

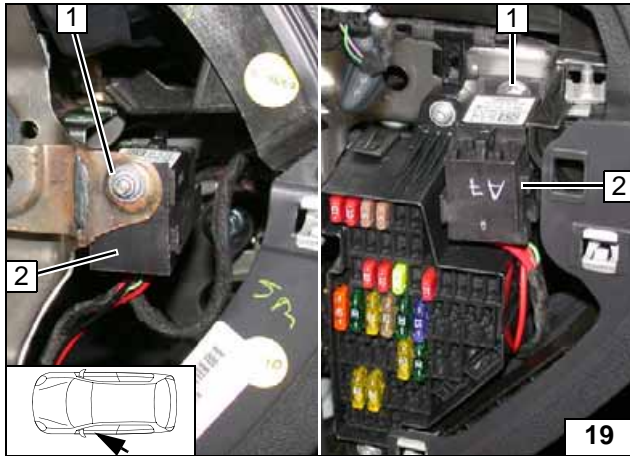

Jetta, Golf

- 1 Existing hole, large diameter washer, M5 self-locking flanged nut
- 2 Fuse holder

Mounting fuse holder in passenger compartment

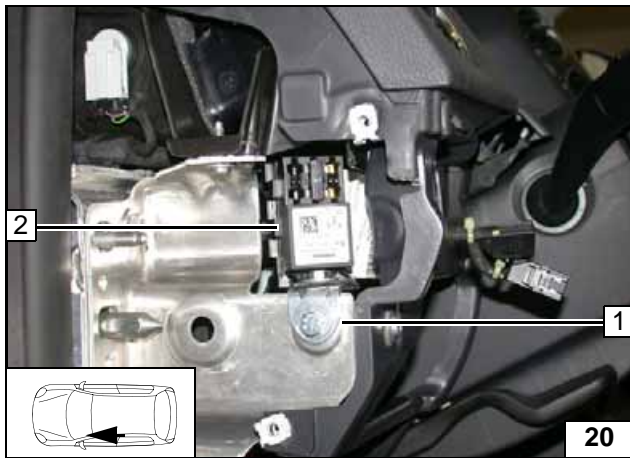

Golf Plus

- 1 M6x20 bolt, angle bracket, existing hole, large diameter washer, M5 self-locking flanged nut
- 2 Fuse holder



Mounting fuse holder in passenger compartment

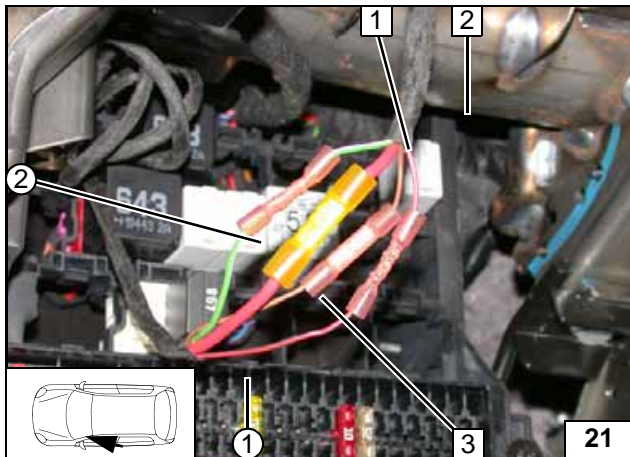

All vehicles

Connect the wiring harness of the fuse holder in passenger compartment 1 to the wiring harness of heater 2 according to the wiring diagram, with same colour wires connected to each other.



Connecting wiring harnesses

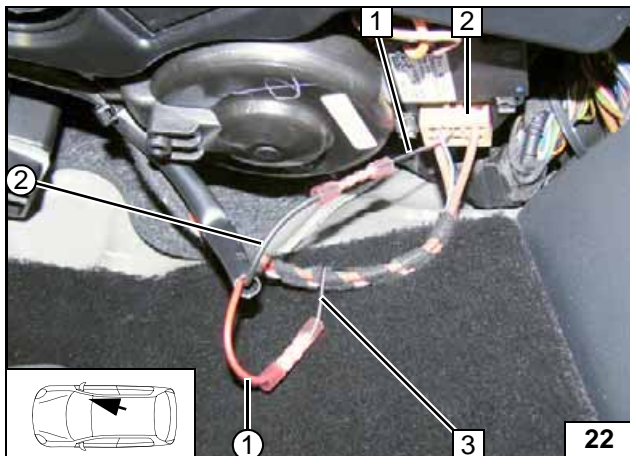

Connection to 6-pin connector T6.. 2 from the fan unit. Produce connections as shown in wiring diagram.

- 1 Black/white (sw/ws) wire from 6-pin connector T6.. Pin 2
- 3 Black/white (sw/ws) wire from A/C control unit
- ① Red (rt) wire of IPCU/E
- ② Black (sw) wire of IPCU/A



Connecting fan unit

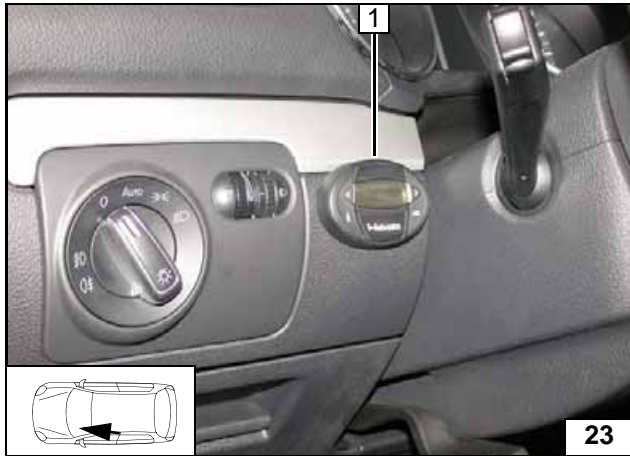

Digital Timer

Golf

1 Digital timer



Mounting digital timer

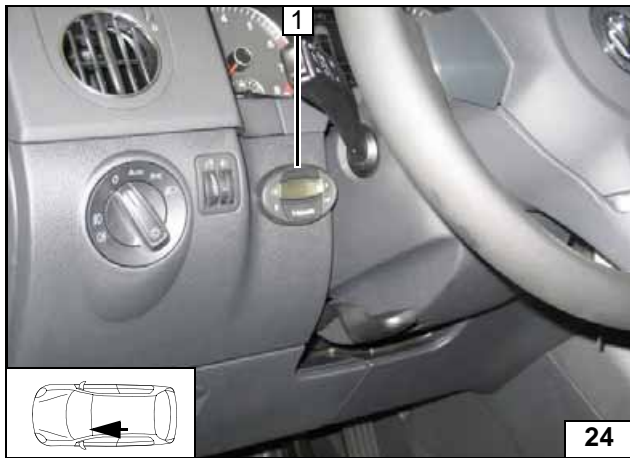

Golf Plus

1 Digital timer



Mounting digital timer

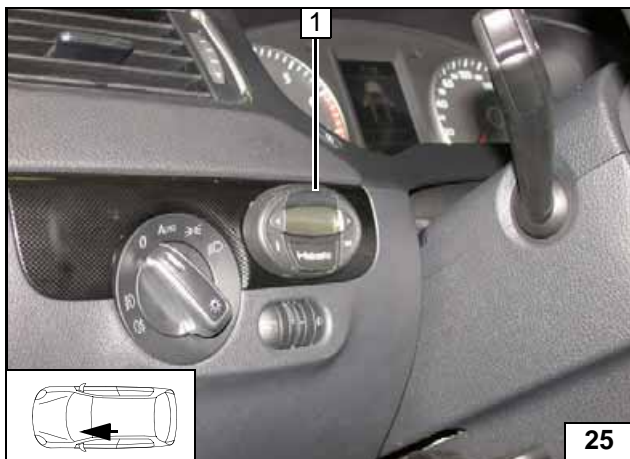

Jetta

1 Digital timer



Mounting digital timer

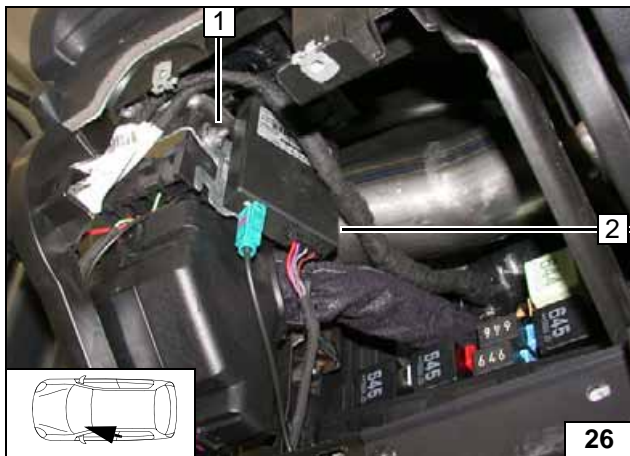

Remote Option (Telestart)

Golf

- 1 M5x16 bolt from fuse holder, large diameter washer, M5 self-locking flanged nut
- 2 Receiver



Mounting receiver

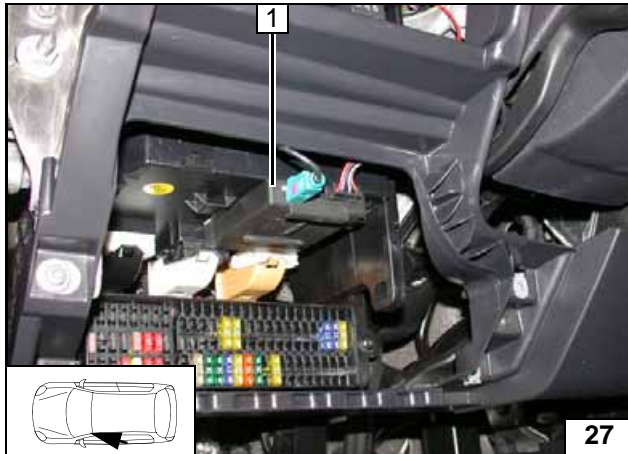

Golf Plus

1 Fasten receiver with adhesive tape.



Mounting receiver

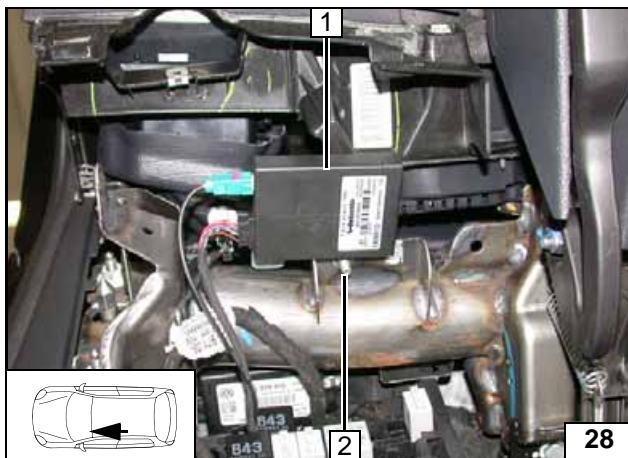

Jetta

1 Receiver
2 M6x20 bolt, flanged nut



Mounting receiver

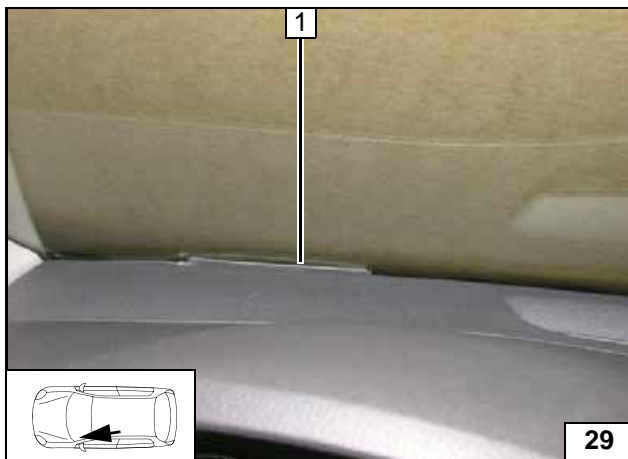

All vehicles

1 Antenna

Mounting antenna

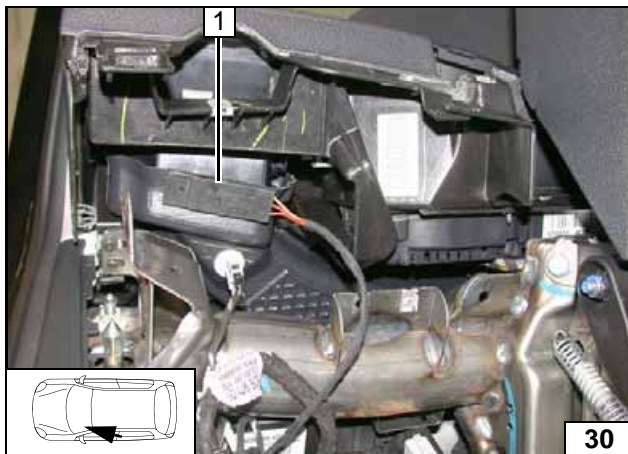

Temperature sensor T100 HTM

Jetta

Fasten temperature sensor 1 with adhesive tape.



Mounting temperature sensor

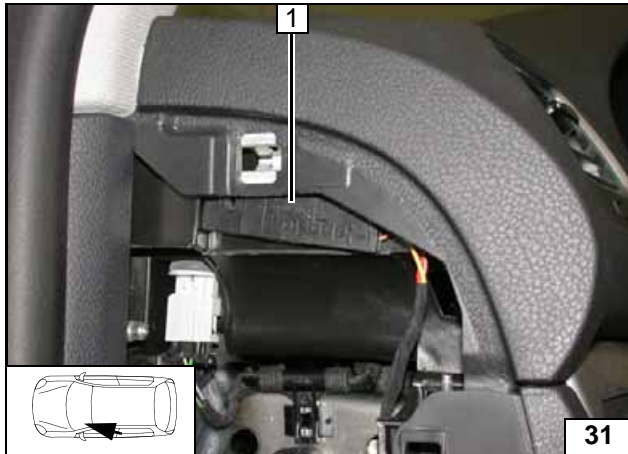

Golf

Fasten temperature sensor 1 with adhesive tape.



Mounting temperature sensor

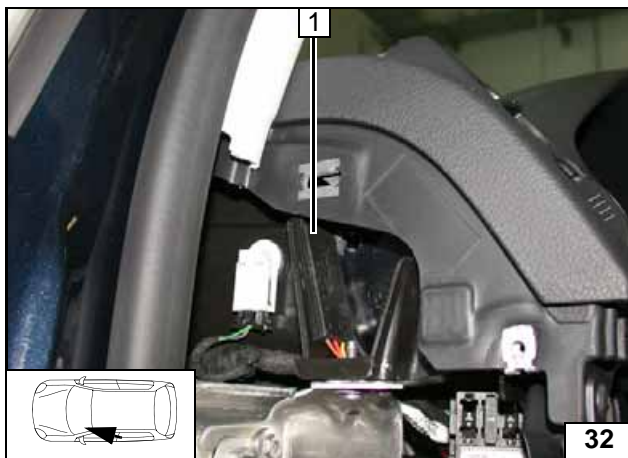

Golf Plus

Fasten temperature sensor 1 with adhesive tape.



Mounting temperature sensor

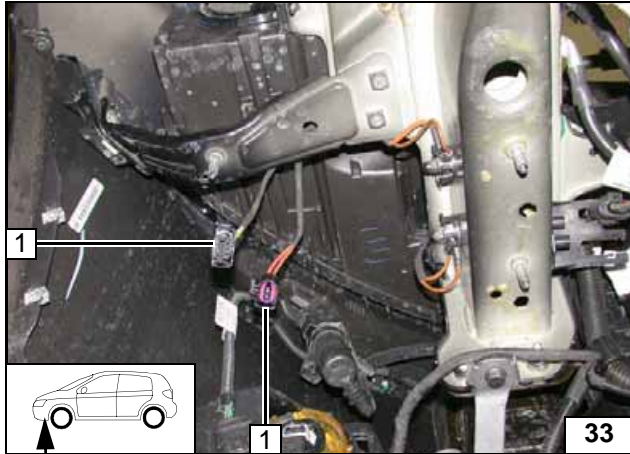
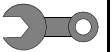

Preparing Installation Location

1 Wiring harness of heater

Routing wiring harness

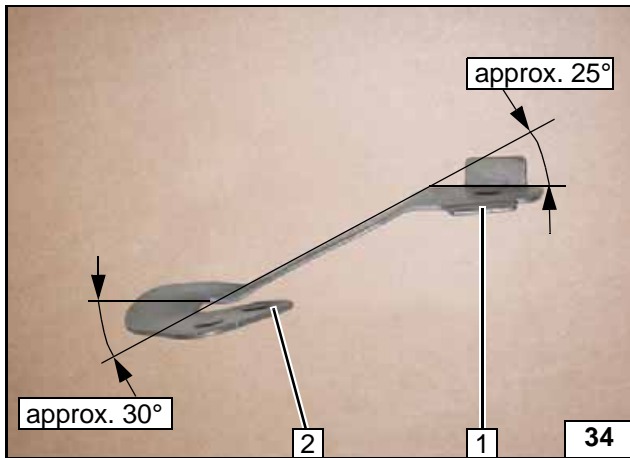

Remove bracket of horn 2 and bend as shown. Bend tab straight.



Processing horn bracket

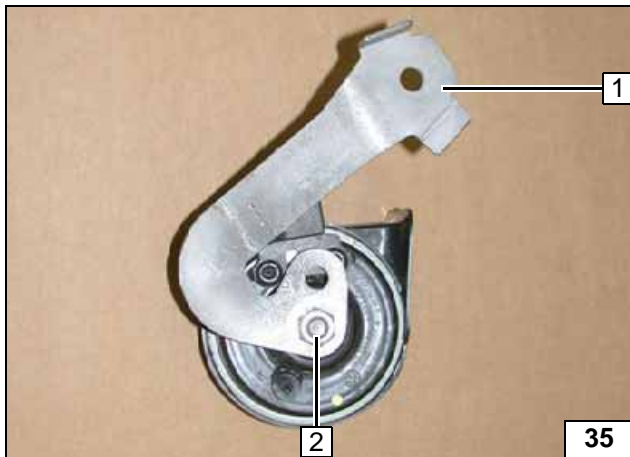

Install horn with original vehicle nut 2 on horn bracket 1.



Premounting horn

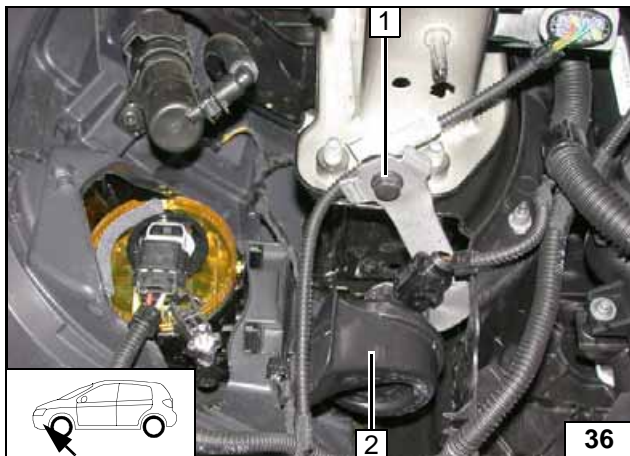

1 Original vehicle bolt
2 Horn



Installing horn

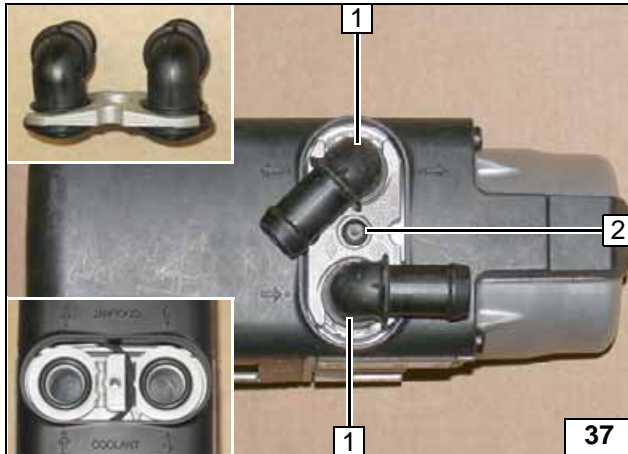
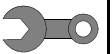

Preparing Heater

- 1 Water connection piece, sealing ring [2x each]
- 2 5x15mm self-tapping bolt, retaining plate of water connection piece



Mounting water connection pieces

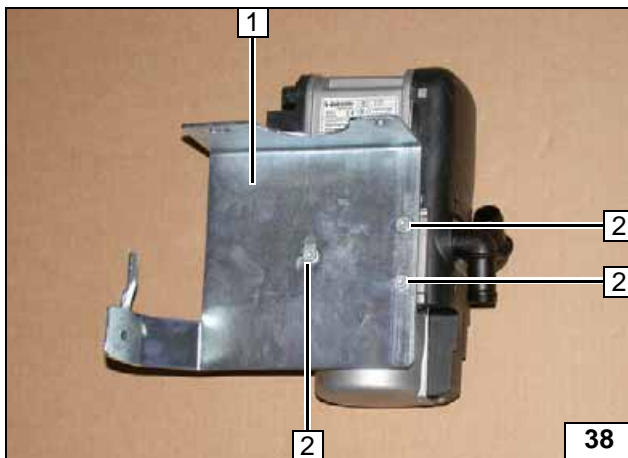

- 1 Bracket section A
- 2 5x13 self-tapping bolt [3x]

Mounting bracket section A

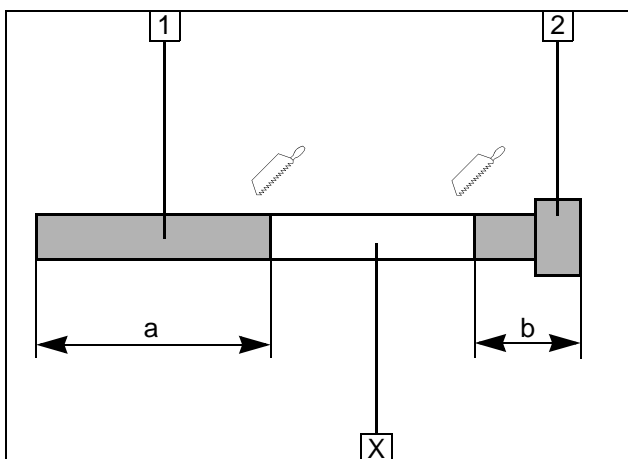

Discard section X.

- 1 Exhaust pipe
a = 470
- 2 Exhaust end section
b = 35



Preparing exhaust pipe

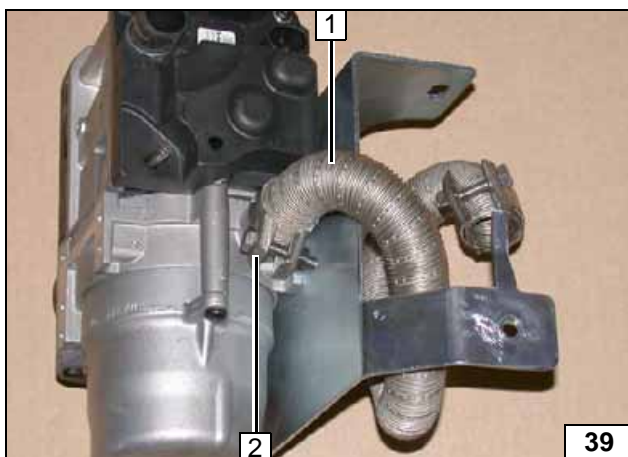

- 1 Exhaust pipe
- 2 Hose clamp

Mounting exhaust pipe

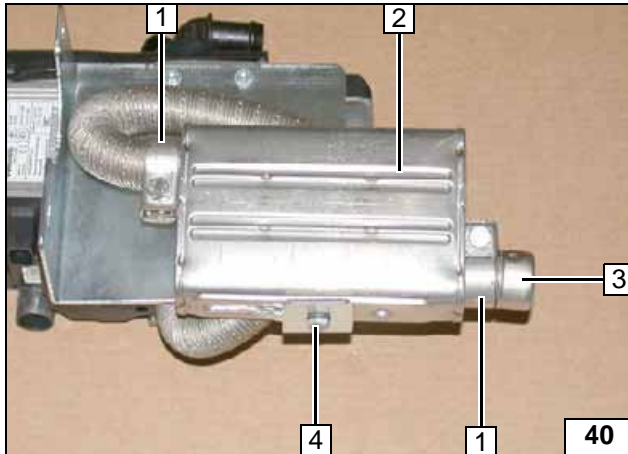
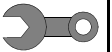

- 1 Hose clamp [2x]
- 2 Silencer
- 3 Exhaust end section
- 4 M6x16 bolt, spring lockwasher

Installing silencer and exhaust end section

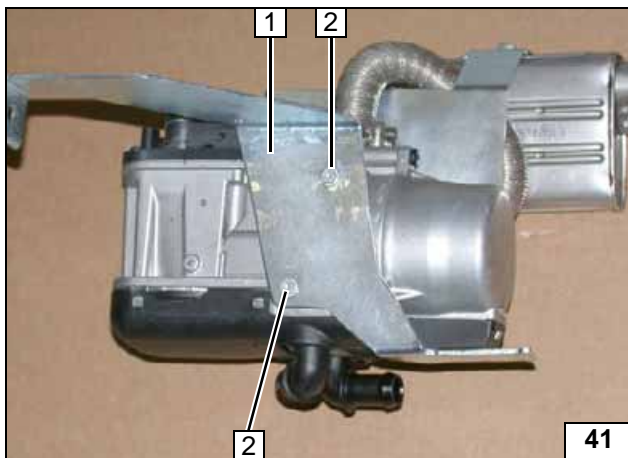

- 1 Bracket section B
- 2 5x13 self-tapping bolt [2x]

Mounting bracket section B

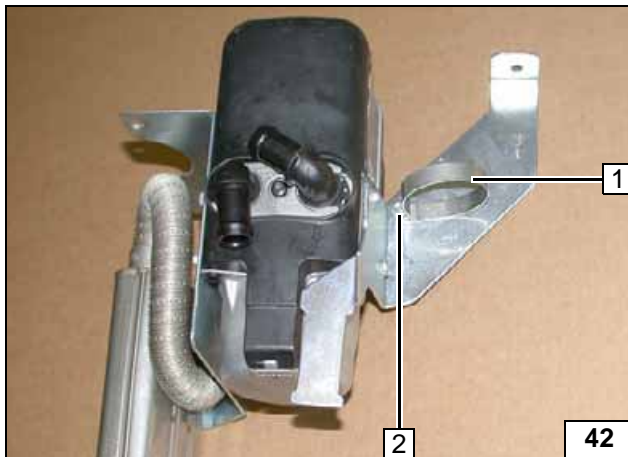

- 1 51mm dia. clamp
- 2 Mount M5x16 bolt, flanged nut loosely

Installing clamp

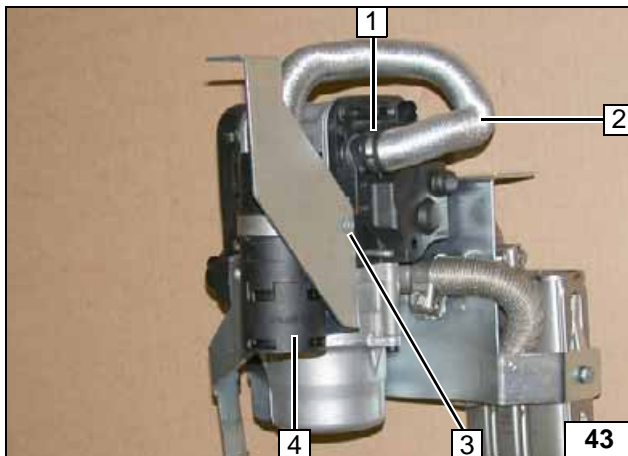

- 1 25 mm dia. clamp
- 2 Combustion air pipe
- 3 Tighten M5x16 bolt, flanged nut
- 4 Silencer

Mounting combustion air pipe

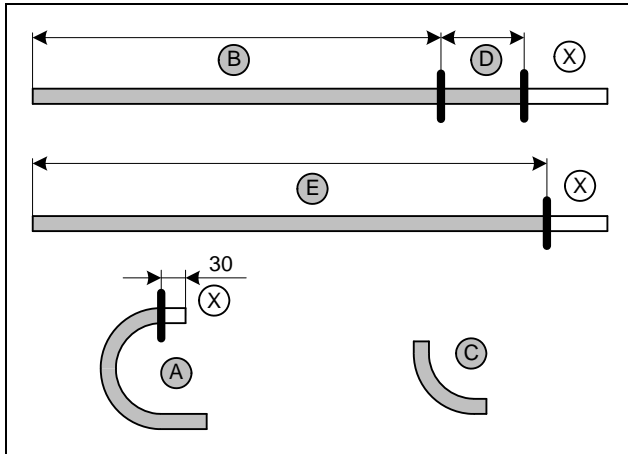
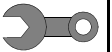

1.4 TSI 90kW

Discard section X.
 Shorten hose A = 20mm dia. 180° moulded hose
 Hose C = 18mm dia. 90° moulded hose

- B = 710
- D = 65
- E = 930



Cutting hoses to length

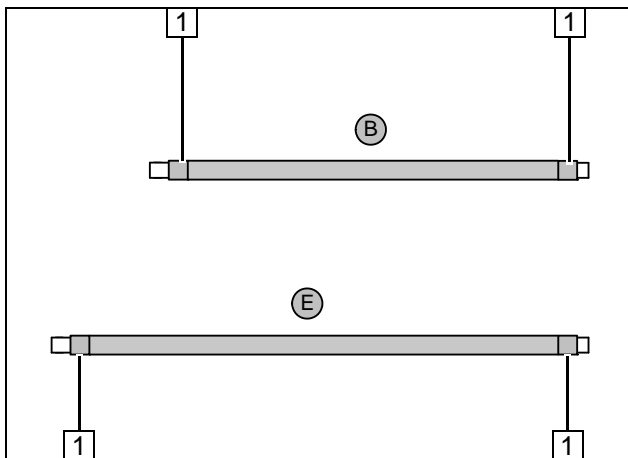

Slide on braided protection hoses and cut to length. Cut heat shrink plastic tubing to length.

- 1 50 mm long heat shrink plastic tubing [4x]



Preparing hoses

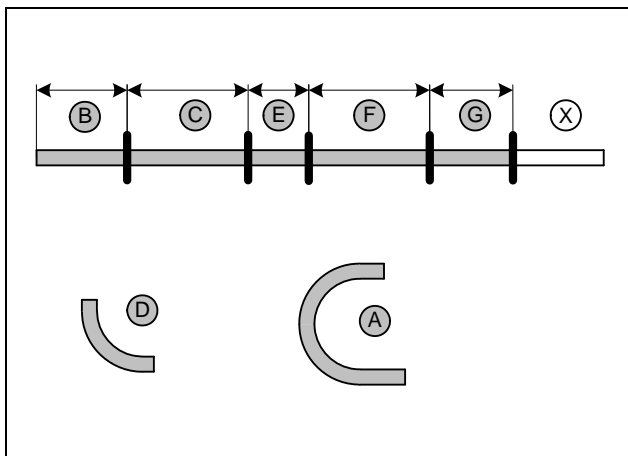

1.4 TSI 118kW

Discard section X.
 Hose A = 20mm dia. 180° moulded hose
 Hose D = 18mm dia. 90° moulded hose

- B = 290
- C = 440
- E = 65
- F = 490
- G = 270



Cutting hoses to length

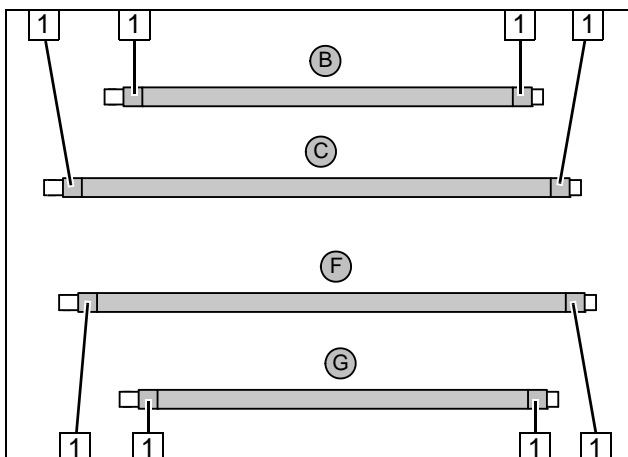

Slide on braided protection hoses and cut to length. Cut heat shrink plastic tubing to length.

- 1 50 mm long heat shrink plastic tubing [8x]



Preparing hoses B, C, F and G

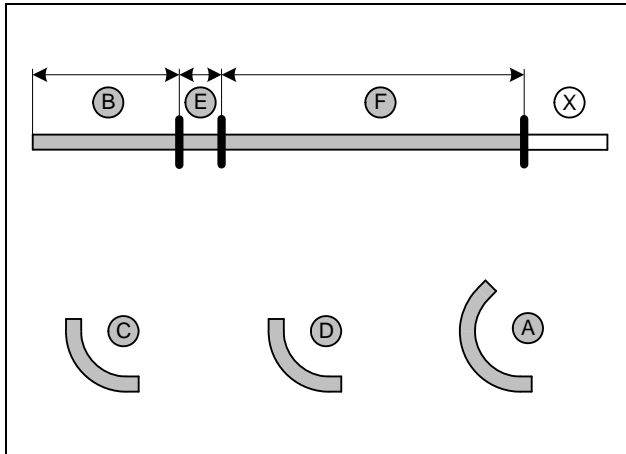
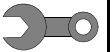

1.6 TDI

Discard section X.
 Hose A = 135°, 15x20 mm dia. moulded hose
 Hose C = 18mm dia. 90° moulded hose
 Hose D = 18mm dia. 90° moulded hose

- B = 640
- E = 65
- F = 900

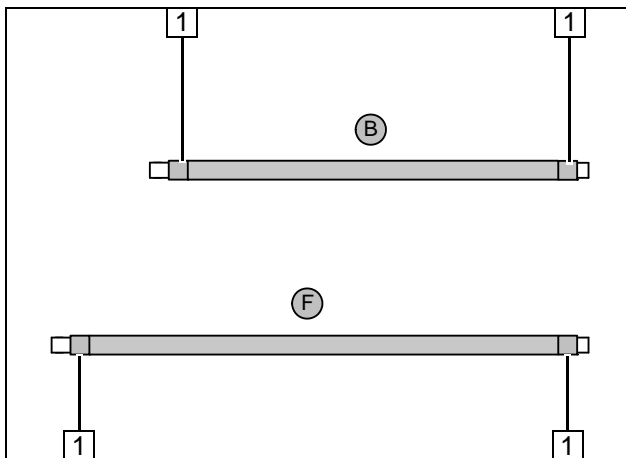

Slide on braided protection hoses and cut to length. Cut heat shrink plastic tubing to length.

- 1 50 mm long heat shrink plastic tubing [4x]

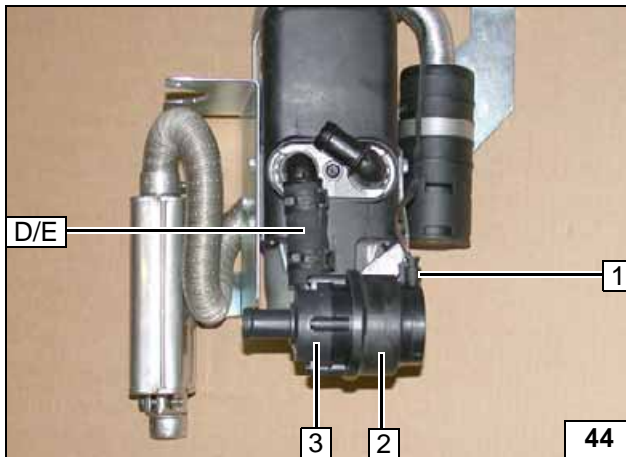

All vehicles

Hose D = 1.4 TSI 90kW
 Hose E = 1.4 TSI 118kW and 1.6 TDI
 All spring clips = 25mm dia.

- 1 Mount wiring harness of circulating pump
- 2 Mounting of circulating pump
- 3 Circulating pump

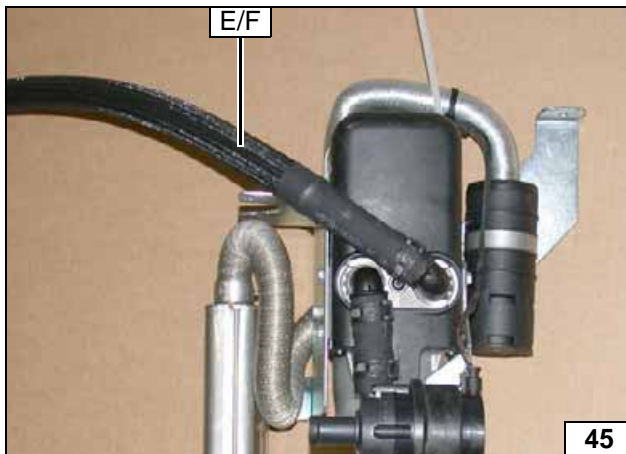

Hose E = 1.4 TSI 90kW
 Hose F = 1.4 TSI 118kW and 1.6 TDI
 Spring clip = 25 mm dia.

Cutting hoses to length

Preparing hoses

Mounting hose and circulating pump

Mounting hose of heater outlet

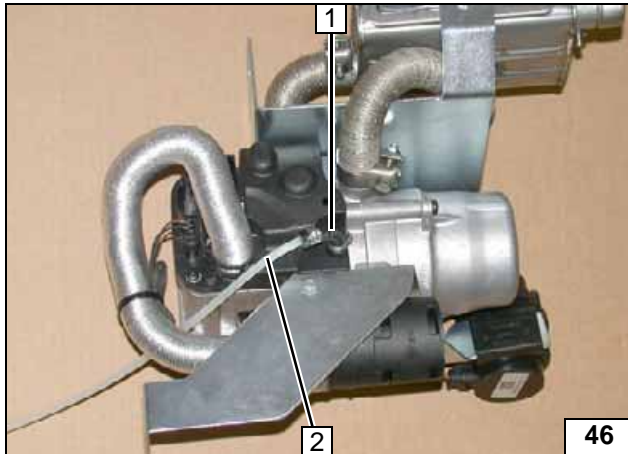
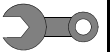

- 1 90° moulded hose, 10mm dia. clamp [2x]
- 2 Fuel line

Premounting fuel line

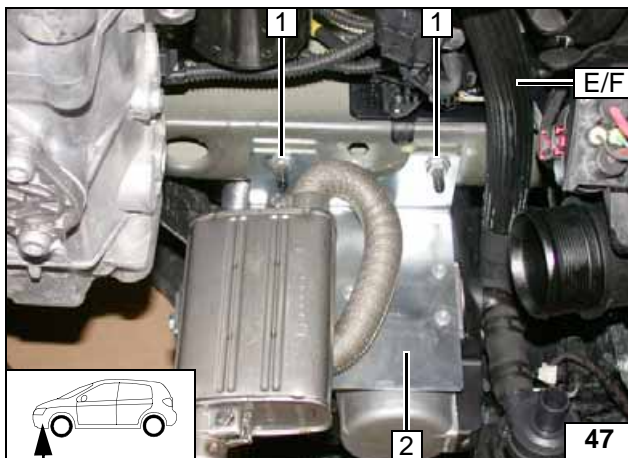

Installing Heater

Image shows 1.6 TDI
 Hose **E** = 1.4 TSI 90kW
 Hose **F** = 1.4 TSI 118kW and 1.6 TDI
 Route hose **E/F** in front of the transmission.

- 1 Original vehicle stud bolt, M8 flanged nut [2x each]
- 2 Bracket section **A**



Mounting heater

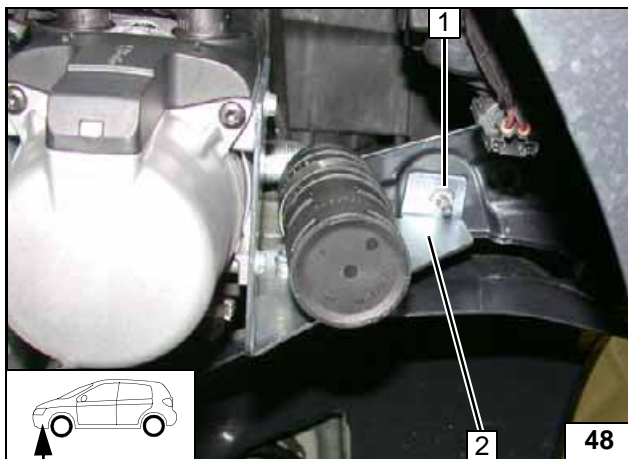

In case of vehicles without stud bolt, produce 8.5mm hole through bracket in cross member and fasten bracket using M8x20 bolt and flanged nut. When drilling, watch for components located behind.

- 1 Original vehicle stud bolt, M8 flanged nut
- 2 Bracket section **B**



Mounting heater

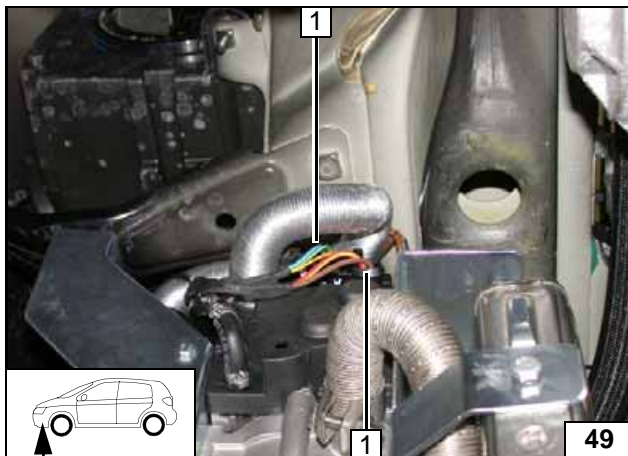

All vehicles

- 1 Wiring harness of heater [2x]

Connecting wiring harness

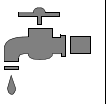



Coolant Circuit 1.4 TSI 90kW

WARNING!

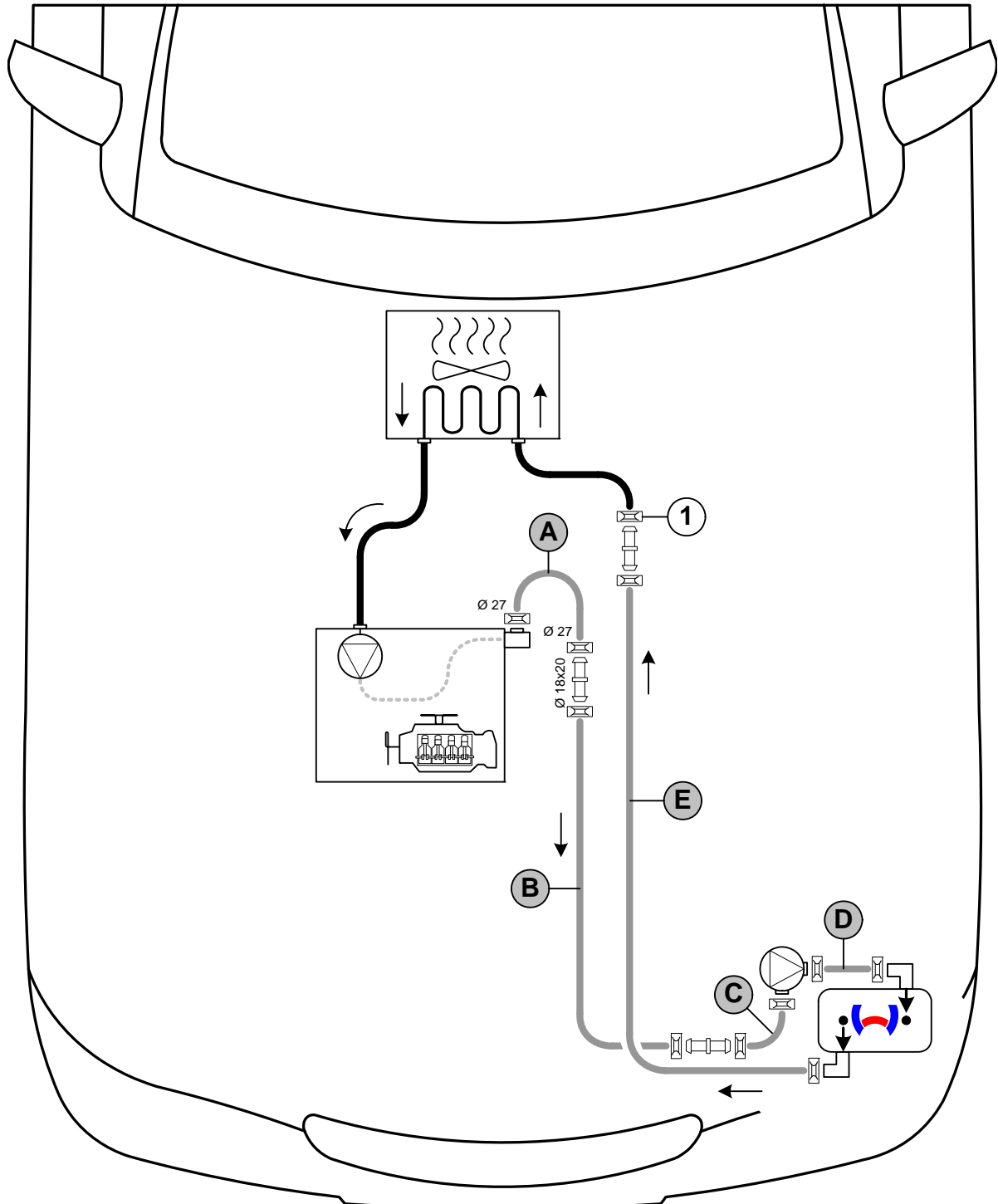
Any coolant running off should be collected in an appropriate container. Install hoses so that they are kink-free. Unless specified otherwise, always fasten using cable ties. Position clamps so that other hoses cannot be damaged. The heater must be filled with coolant when installing the hoses. The connection should be "inline" based on the following diagram:



Hose installation diagram

All spring clips without a specific designation  = 25mm dia.
 1 = Original vehicle spring clip 
 All connecting pipes without a specific designation  = 18x18 mm dia.



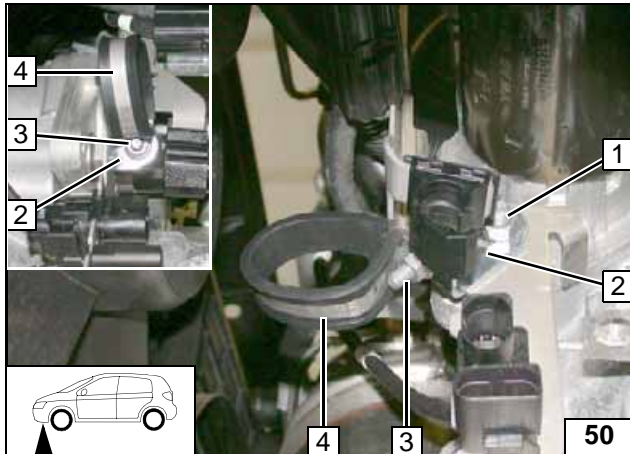

- 1 Original vehicle stud bolt, original vehicle nut
- 2 Angle bracket
- 3 M6x20 bolt, flanged nut
- 4 38mm dia. rubber-coated p-clamp

Mounting p-clamp

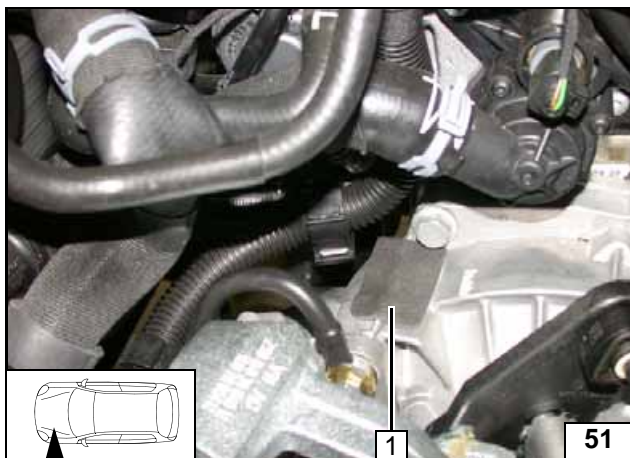

Deburr and paste foam strip 1.



Pasting foam strip

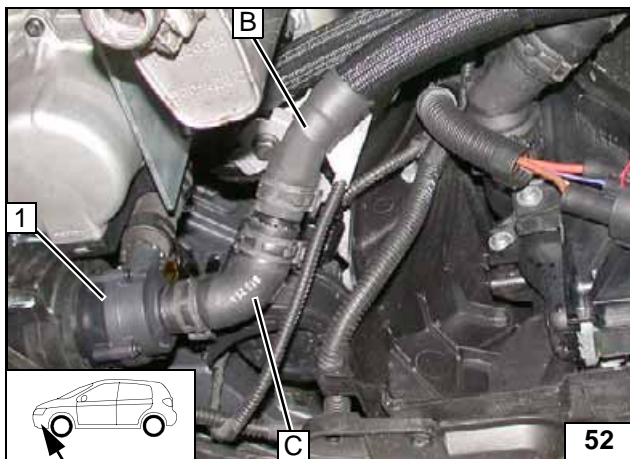

1 Circulating pump

Circulating pump connection

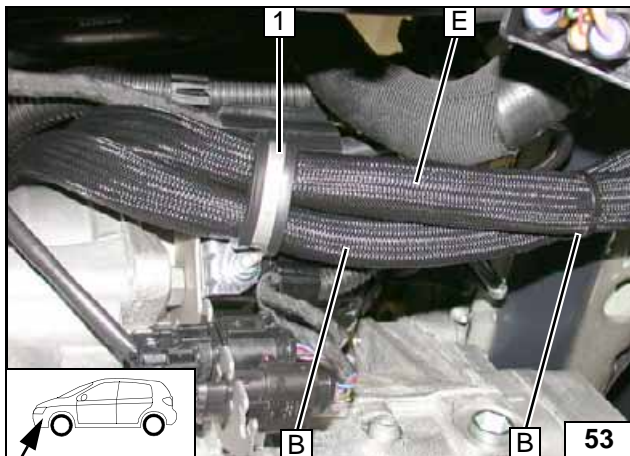

Route hoses B and E upward in front of the transmission, through rubber-coated p-clamp 1.

1 Cable tie



Routing in engine compartment

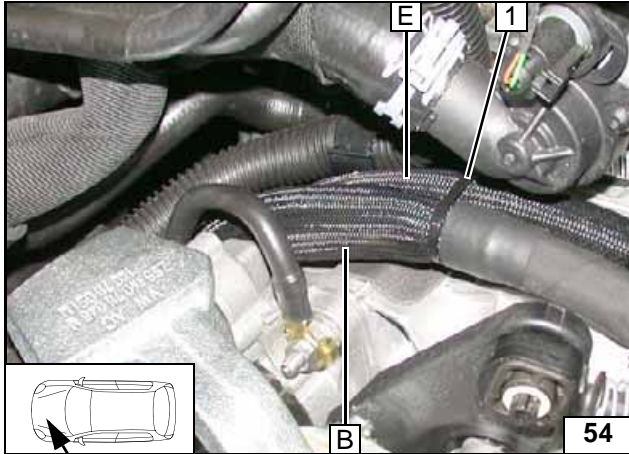
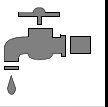

Route hoses **B** and **F** on top of the transmission to the cutting point.

1 Cable tie



Routing in engine compartment

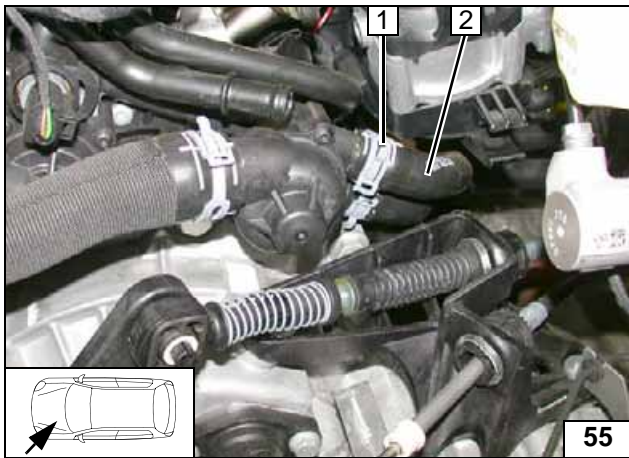

Pull off hose on engine outlet / heat exchanger inlet **2** from connection piece of engine outlet. Spring clip **1** will be reused.



Cutting point

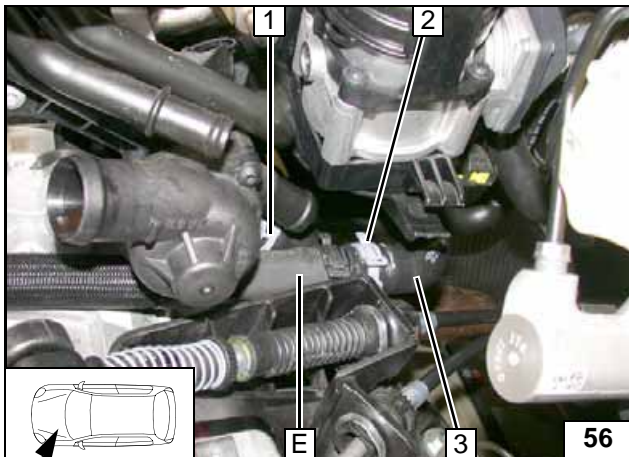

Original vehicle hoses have only been removed for the purpose of better presentation. Align original vehicle spring clip **1**.

2 Original vehicle spring clip
3 Hose on heat exchanger inlet



Connecting heat exchanger inlet

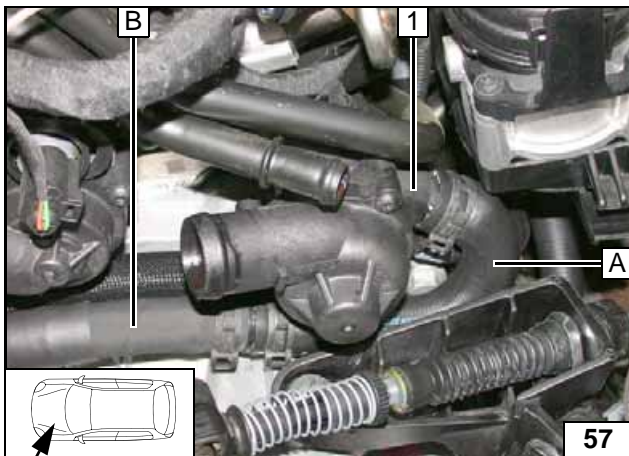

1 Engine outlet connection piece

Connecting engine outlet

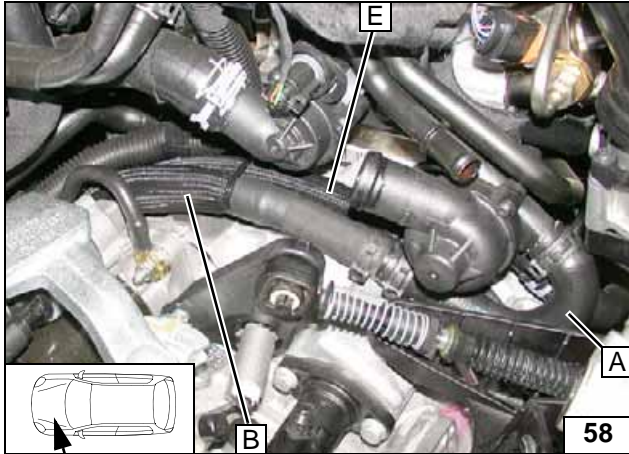

Ensure sufficient distance from neighbouring components, correct if necessary.



Aligning hoses



Coolant Circuit 1.4 TSI 118kW

WARNING!

Any coolant running off should be collected in an appropriate container. Install hoses so that they are kink-free. Unless specified otherwise, always fasten using cable ties. Position clamps so that other hoses cannot be damaged. The heater must be filled with coolant when installing the hoses. The connection should be "inline" based on the following diagram:

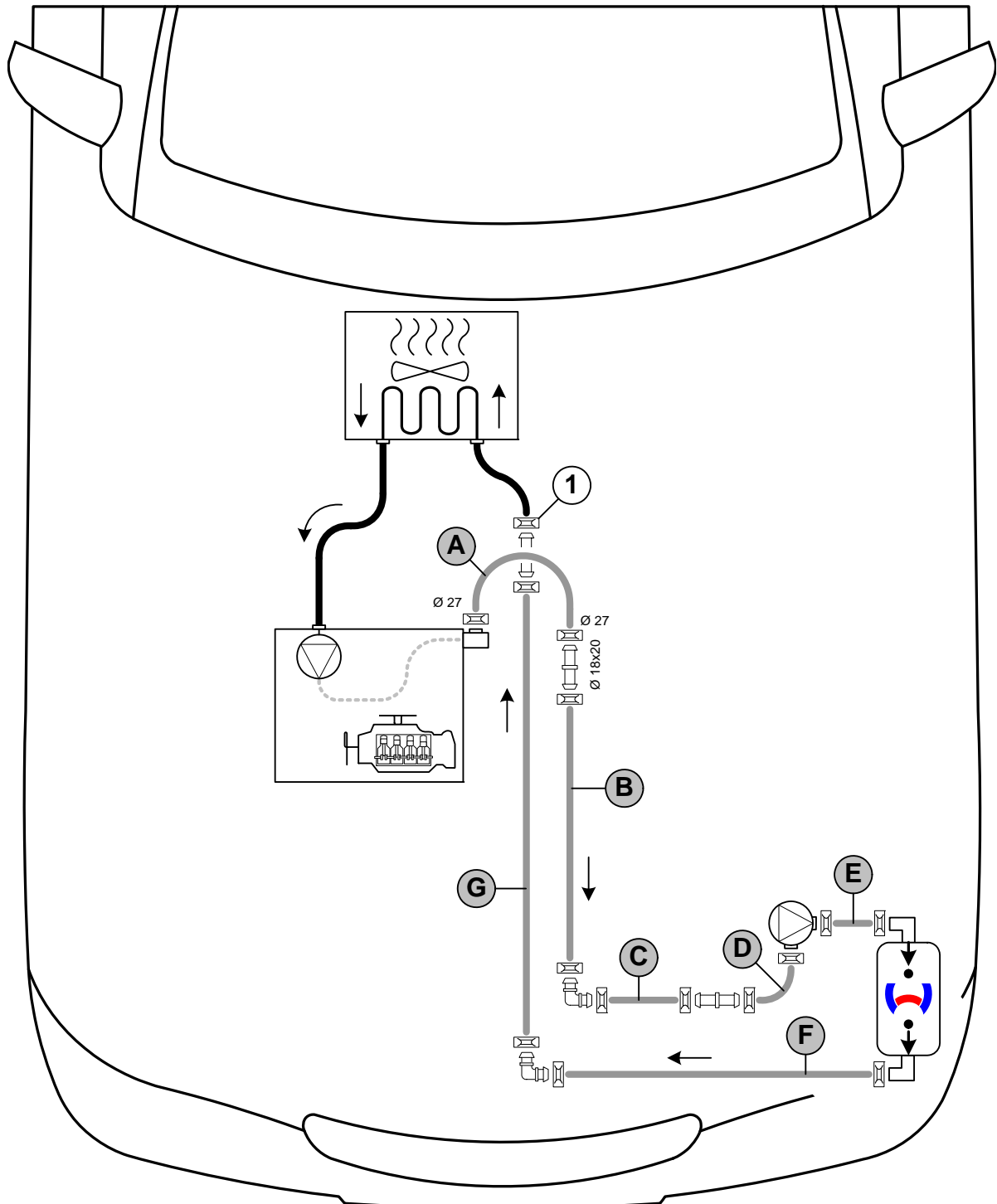

Hose in-
stallation
diagram

All spring clips without a specific designation  = 25mm dia.

1 = Original vehicle spring clip .

All connecting pipes without a specific designation  and  = 18x18mm dia.



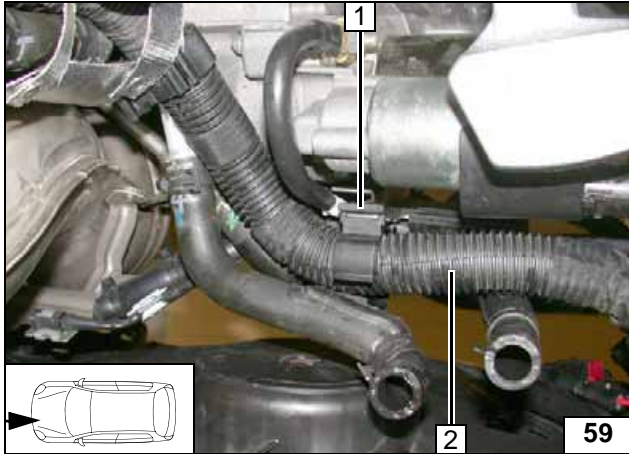

- 1 Remove and discard original vehicle retaining clip
- 2 Original vehicle wiring harness

Removing clip

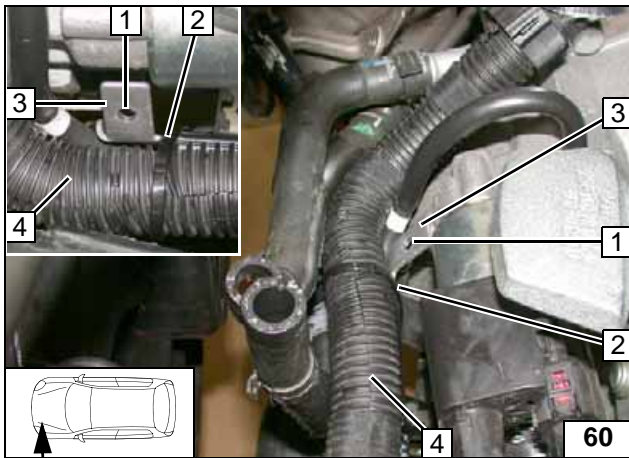

Bend bracket 3 as shown. Drill out hole at position 1 to 6mm dia. Fasten original vehicle wiring harness with cable tie to plug connection.

- 2 Cable tie (see following image)
- 4 Original vehicle wiring harness



Preparing bracket

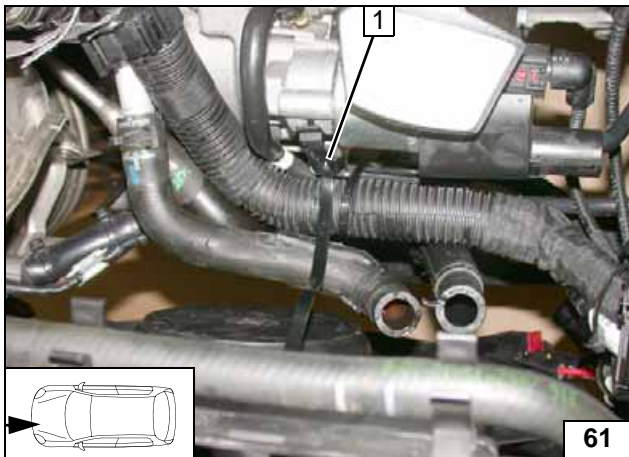

- 1 Clip-type cable tie

Installing clip-type cable tie

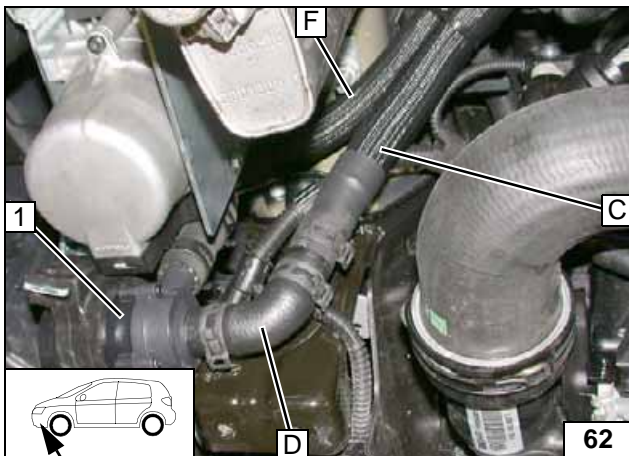

- 1 Circulating pump

Circulating pump connection

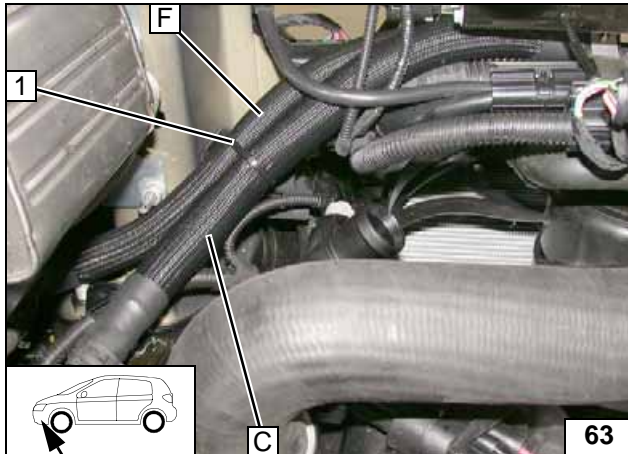

Route hoses **C** and **F** behind the radiator in the upward direction.



Routing in engine compartment

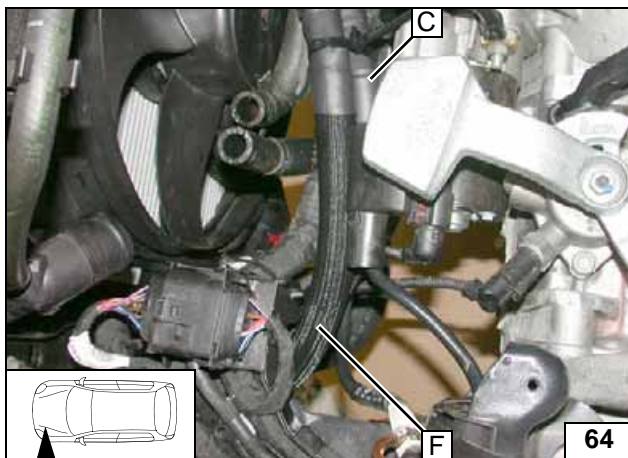

Routing in engine compartment

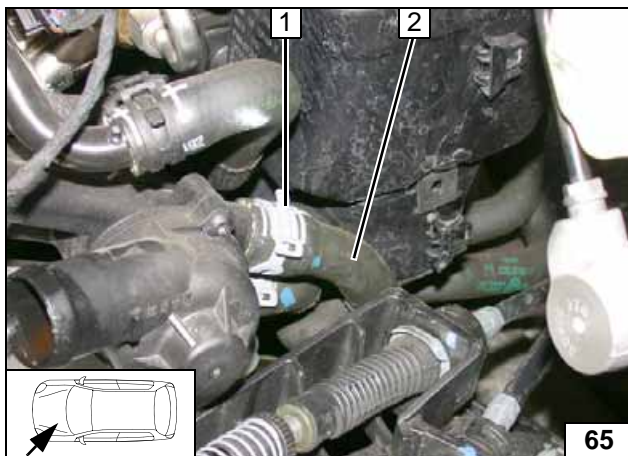

Pull off hose on engine outlet / heat exchanger inlet **2** from connection piece of engine outlet. Spring clip **1** will be reused.



Cutting point

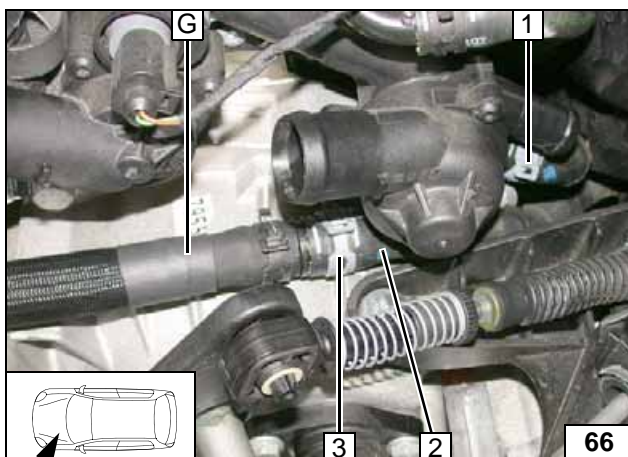

Original vehicle hoses have only been removed for the purpose of better presentation. Align original vehicle spring clip **1**.

- 2** Hose on heat exchanger inlet
- 3** Original vehicle spring clip



Connecting heat exchanger inlet

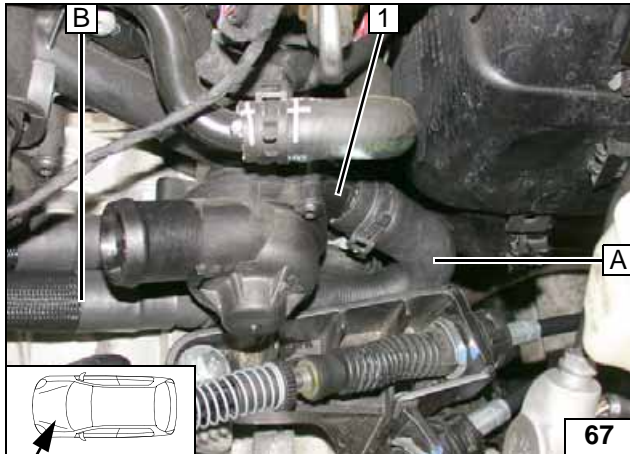

1 Engine outlet connection piece

Connect-
ing engine
outlet

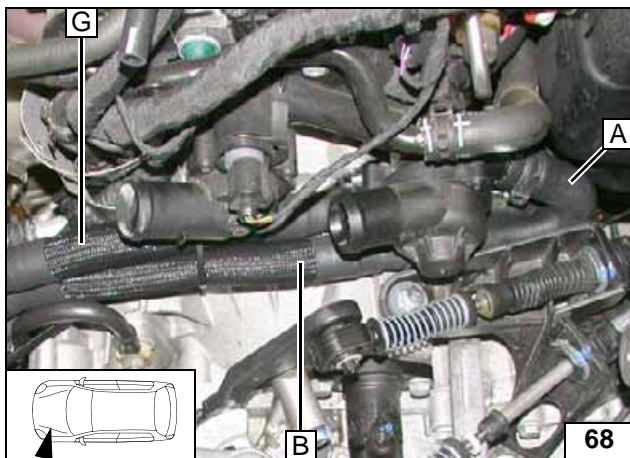

Routing in
engine
compart-
ment

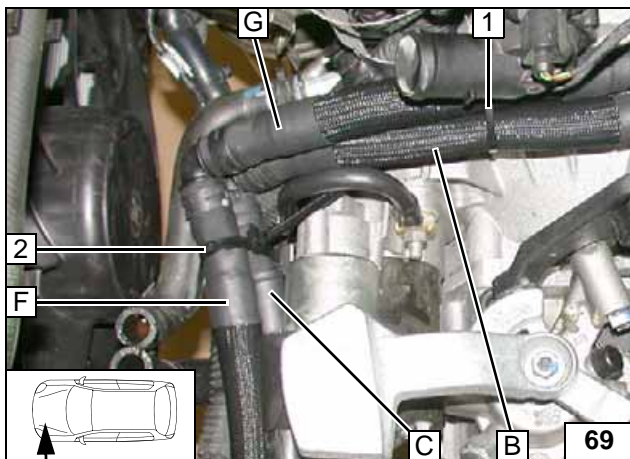

Align hoses. Ensure sufficient distance from neighbouring components, correct if necessary.

- 1 Cable tie
- 2 Close clip-type cable tie



Connect-
ing hoses



Install original vehicle hoses. Ensure sufficient distance from neighbouring components, correct if necessary.



Aligning
hoses

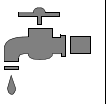



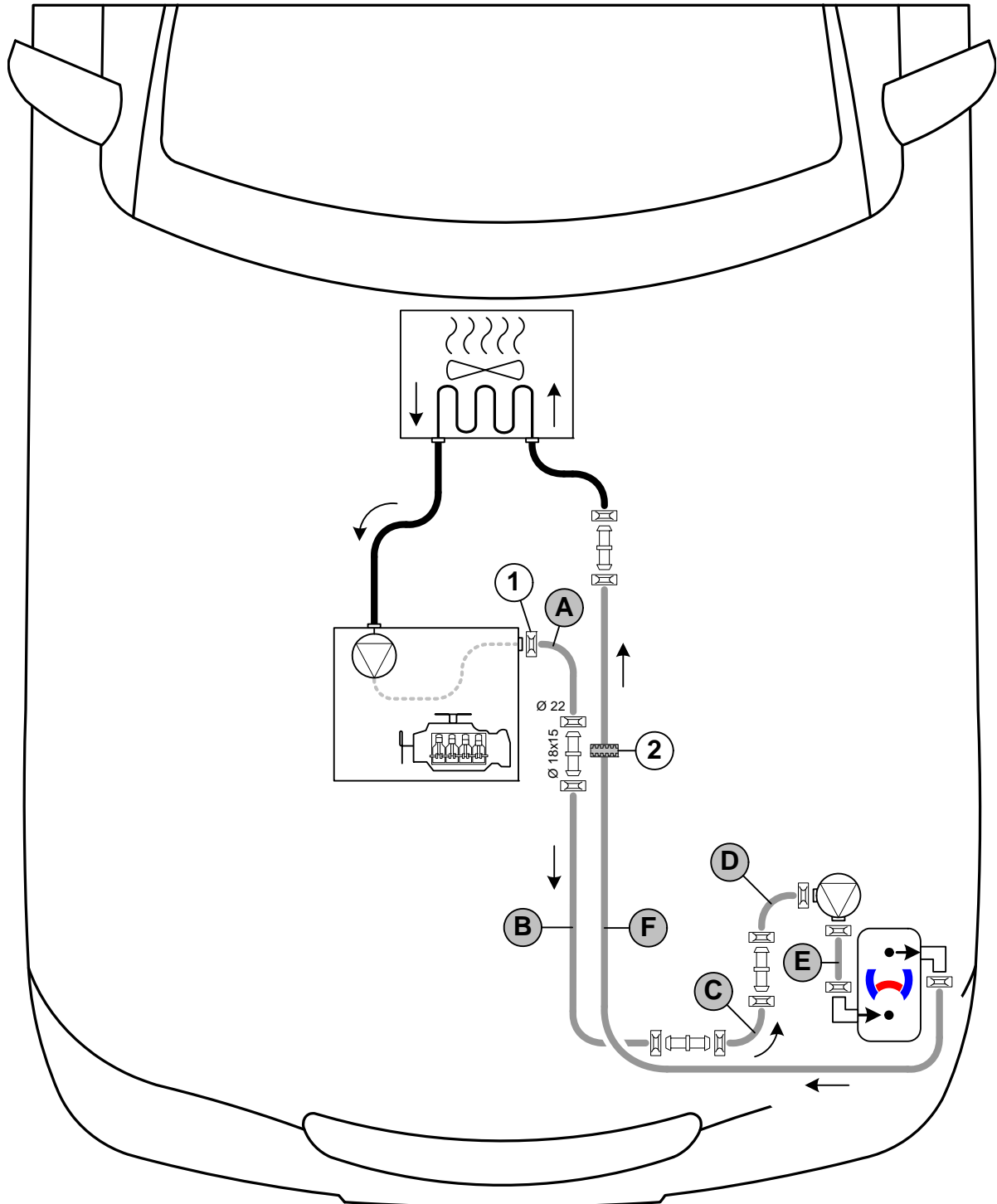

Coolant Circuit 1.6 TDI

WARNING!

Any coolant running off should be collected in an appropriate container. Install hoses so that they are kink-free. Unless specified otherwise, always fasten using cable ties. Position clamps so that other hoses cannot be damaged. The heater must be filled with coolant when installing the hoses. The connection should be "inline" based on the following diagram:



Hose in-
stallation
diagram

All spring clips without a specific designation  = 25mm dia.
 1 = Original vehicle spring clip . 2 = Black (sw) rubber isolator .
 All connecting pipes without a specific designation  = 18x18 mm dia.



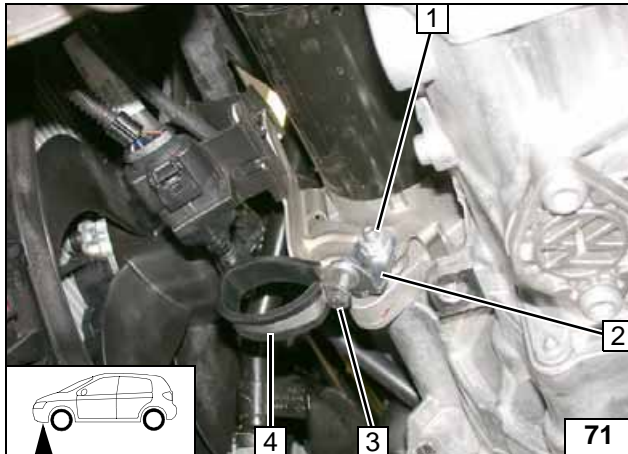

- 1 Original vehicle stud bolt, original vehicle nut
- 2 Angle bracket
- 3 M6x20 bolt, flanged nut
- 4 38mm dia. rubber-coated p-clamp

Mounting p-clamp

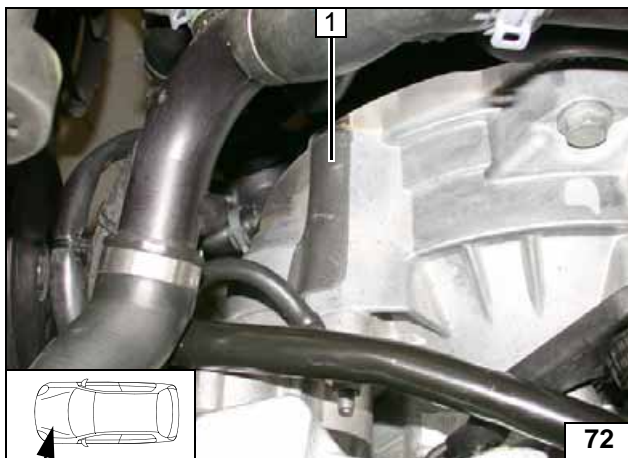

Deburr and paste foam strip 1.



Pasting foam strip

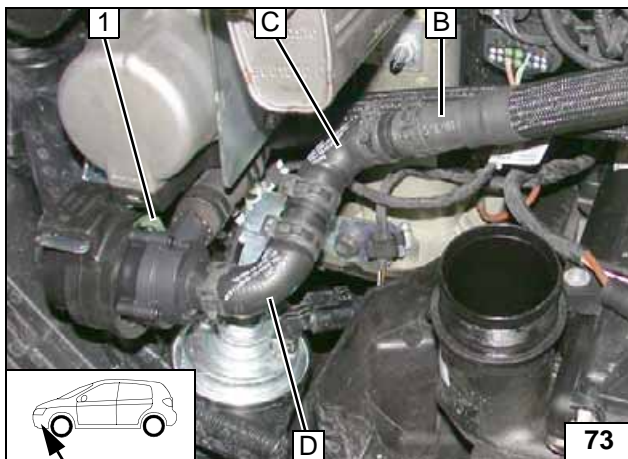

1 Circulating pump

Circulating pump connection

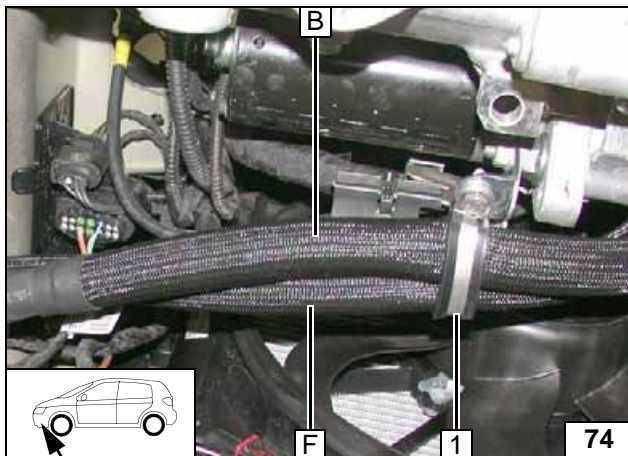

Route hoses **B** and **F** through rubber-coated p-clamp 1.



Routing in engine compartment

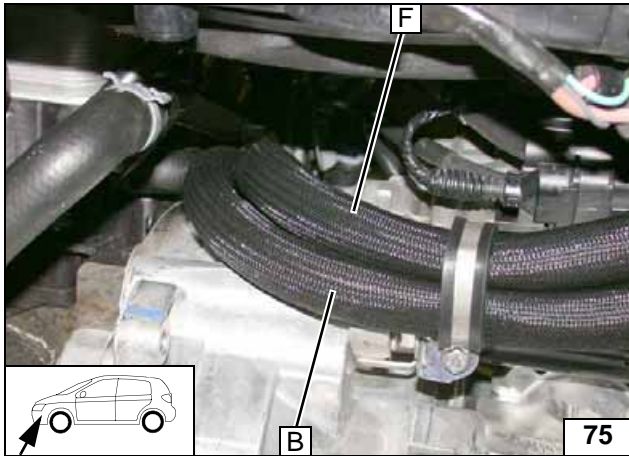
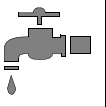

Route hoses **B** and **F** before the transmission in the upward direction.



Routing in engine compartment

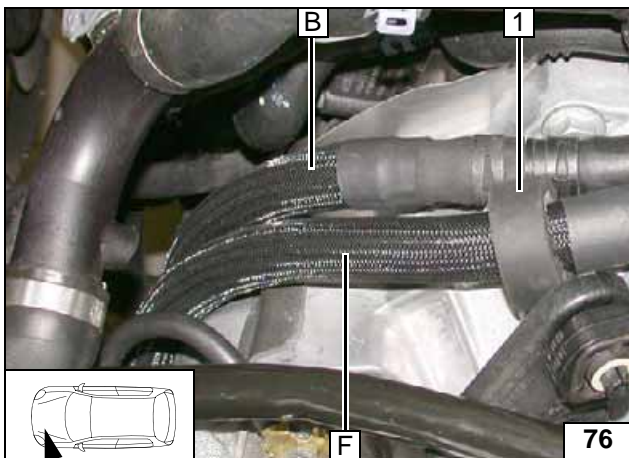

Route hoses **B** and **F** on top of the transmission to the cutting point. Push black (sw) rubber isolator **1** onto hose **F**.



Routing in engine compartment

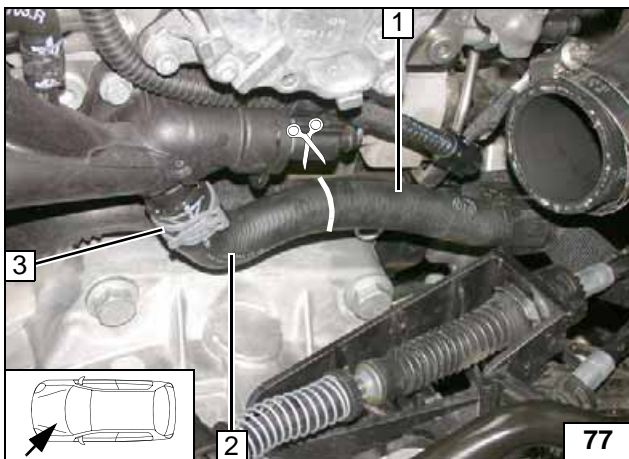

Cut off hose on engine outlet/heat exchanger inlet at marking. Remove hose on engine outlet **2** and discard. Spring clip **3** will be reused.



Cutting point

- 1 Hose section of heat exchanger inlet

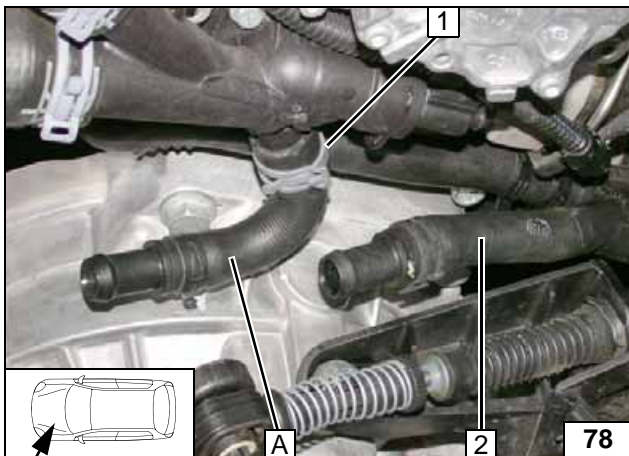

Premount connecting pipes and spring clips.



Preparing connection of engine outlet and heat exchanger inlet

- 1 Original vehicle spring clip
- 2 Hose on heat exchanger inlet

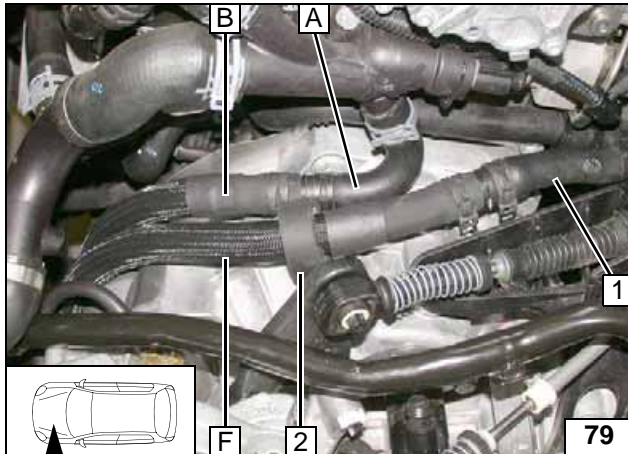

Align black (sw) rubber isolator 2 on gear change.

1 Hose on heat exchanger inlet



**Connect-
ing engine
outlet and
heat ex-
changer in-
let**

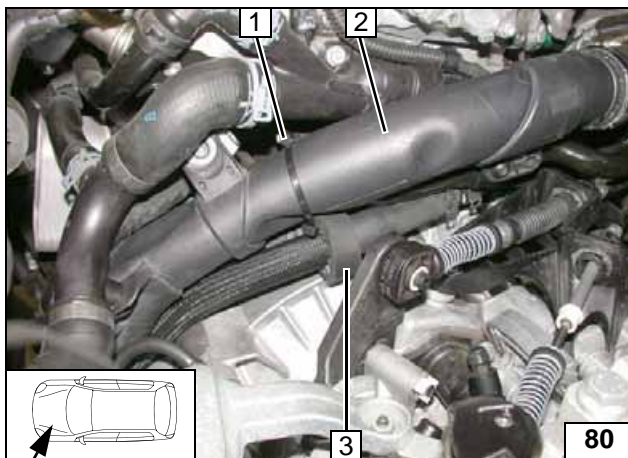

Align hoses. Fasten black (sw) rubber isolator 3 with cable tie 1 on charge air pipe 2. Ensure sufficient distance from neighbouring components, correct if necessary.



**Mounting
charge air
pipe**

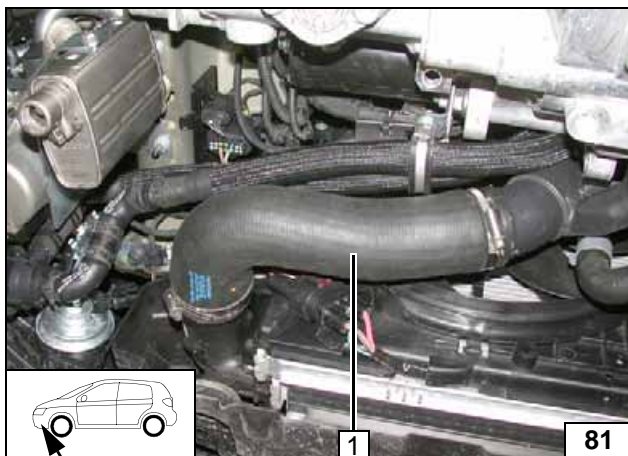

Align hoses. Ensure sufficient distance from neighbouring components, correct if necessary.

1 Charge air hose



**Mounting
charge-air
hose**



Fuel

CAUTION!

Open the vehicle's fuel tank cap, ventilate the tank and then re-close the tank lock.

Catch any fuel running off in an appropriate container.

Route fuel line and metering pump wiring harness so that they are protected against stone impact. Unless specified otherwise, always fasten using cable ties. Mount the fuel line and wiring harness with rub protection on sharp edges.

WARNING!

The fuel line and wiring harness are routed to the metering pump as shown in the wiring harness routing diagram.



Route fuel line and wiring harness of metering pump in 1130mm corrugated tube 1 to firewall.



Route fuel line and wiring harness of metering pump 1 to the firewall behind the insulation mat on the right vehicle side.

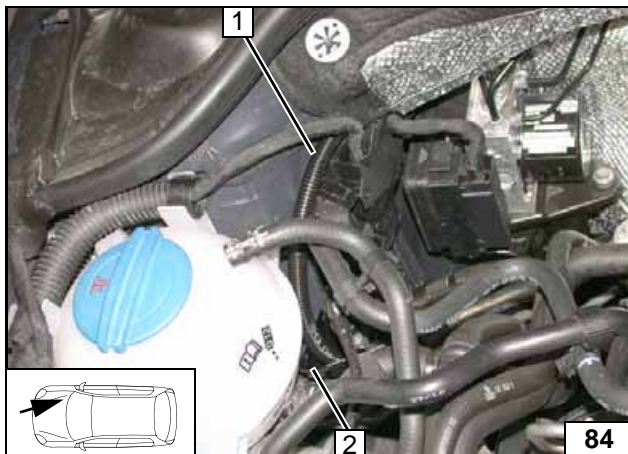

Cut off approx. 300mm from the 10mm dia. corrugated tube and slide on to fuel line and wiring harness of metering pump. Guide fuel line and wiring harness of metering pump 1 into original vehicle line duct 2 and route to underbody.



Routing lines



Routing lines



Routing lines



- 1 Fuel line and wiring harness of metering pump
- 2 Original vehicle line duct

Routing lines

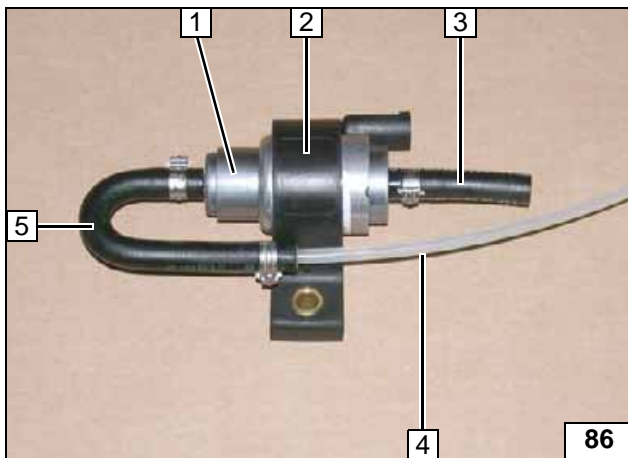

Cut off approx. 600mm from fuel line.

- 1 Metering pump
- 2 Mounting of metering pump
- 3 Hose section, 10mm dia. clamp
- 4 600mm fuel line
- 5 180° moulded hose, 10mm dia. clamp [2x]

Premounting metering pump

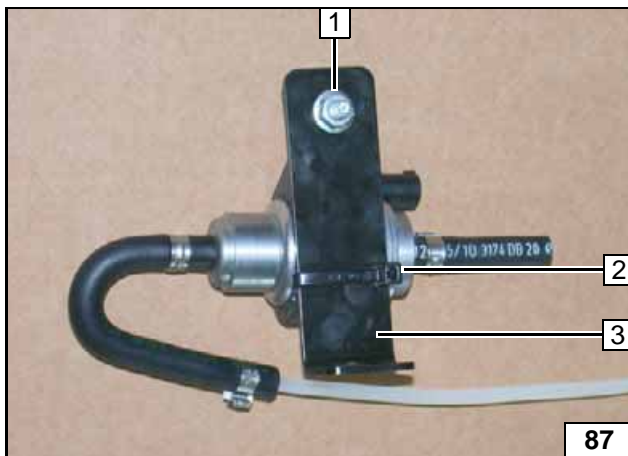

- 1 M6x25 bolt, flanged nut
- 2 Cable tie
- 3 Bracket of metering pump

Premounting metering pump

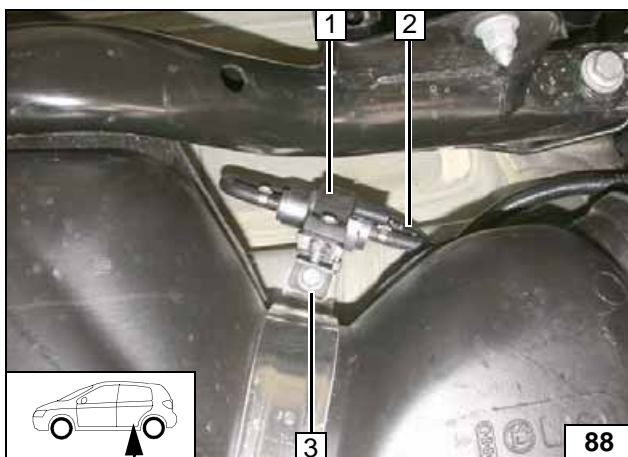

Slide approx 500mm of 10mm dia. corrugated tube 2 onto fuel line of fuel standpipe and route to the fuel-tank sending unit.

- 1 Preassembled metering pump
- 3 Original vehicle bolt

Mounting metering pump

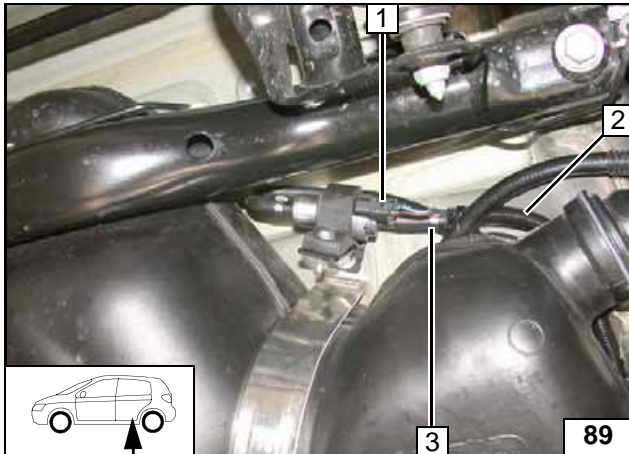

- 1 Wiring harness of metering pump, connector mounted
- 2 Fuel line of heater and wiring harness of metering pump in corrugated tube
- 3 10 mm dia. clamp



**Connect-
ing meter-
ing pump**

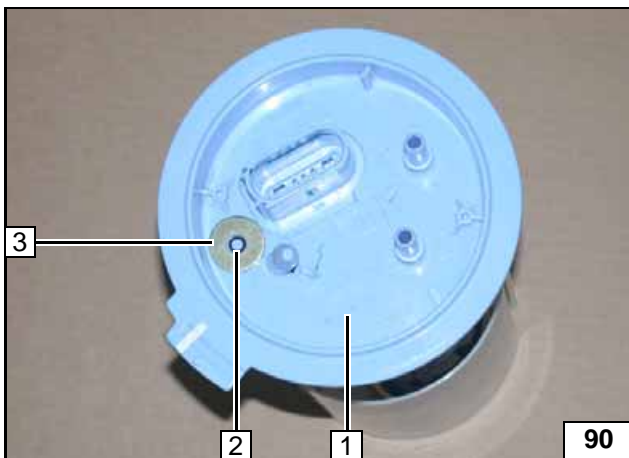

Remove fuel-tank sending unit 1 in accordance with manufacturer's instructions. Position large diameter washer 3 as shown.

- 2 6 mm dia. hole



**Fuel ex-
traction**

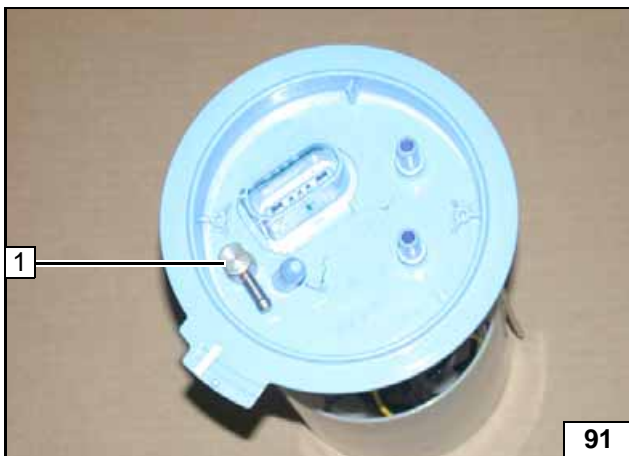

Shape fuel standpipe 1 according to template, cut to length and install.



**Installing
fuel stand-
pipe**

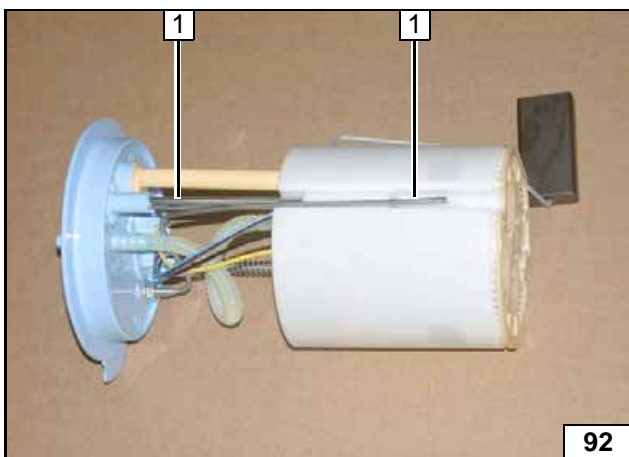

Align fuel standpipe 1 as shown.



**Installing
fuel stand-
pipe**

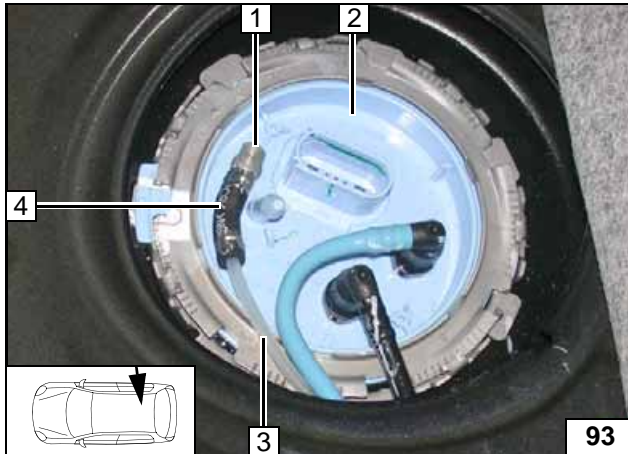

Mount fuel-tank sending unit **2** in accordance with manufacturer's instructions. Ensure sufficient spacing between hose section **4** and edge of locking ring.

- 1** Fuel standpipe
- 3** Fuel line
- 4** Hose section, 10 mm dia. clamp [2x]



**Mounting
fuel-tank
sending
unit**

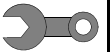

Wheel-Well Inner Panel / Underride Protection

Cut out wheel-well inner panel 1 at the marking 2.



Cutting out wheel-well inner panel

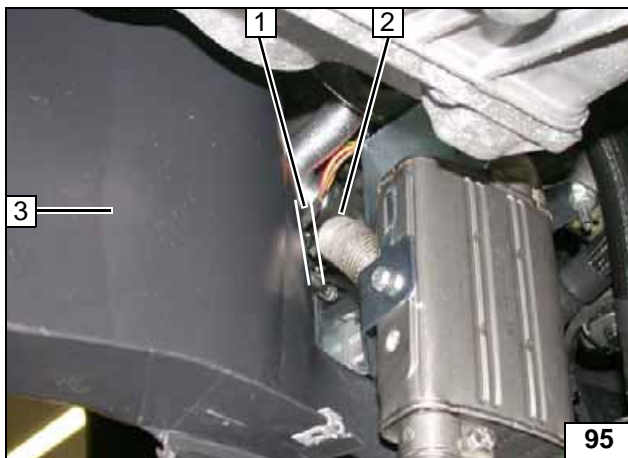

Ensure sufficient distance between wheel-well inner panel 3 and exhaust pipe 2 at position 1 (min. 10mm)!



Mounting wheel-well inner panel

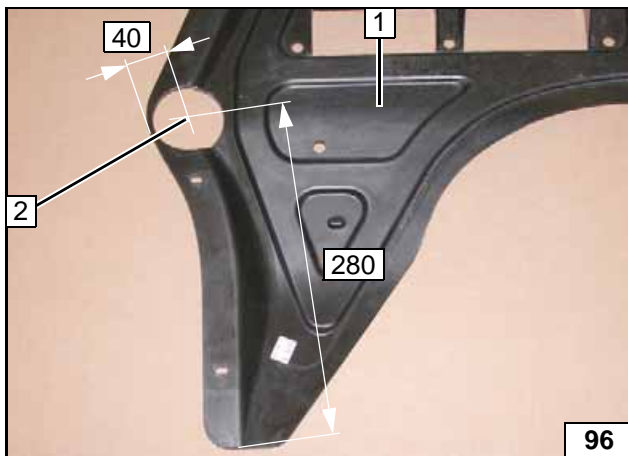

1 Underride protection
2 60mm dia. hole



Cutting out underride protection

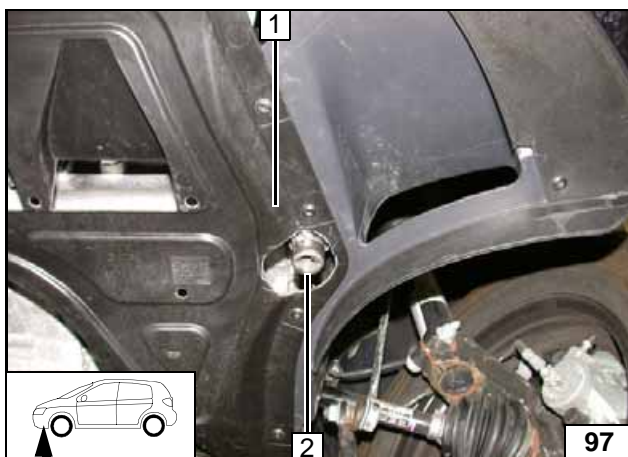

Align exhaust end section 2 in centre of hole and flush with underride protection 1.



Aligning exhaust end section



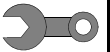

Final Work

WARNING!

Mount removed parts in reverse order. Check all hoses, clamps and all electrical connections for firm seating. Insulate and tie back all loose lines.

Only use manufacturer-approved coolant. Spray the heater components with anti-corrosion wax (Tectyl 100K, Order No. 111329).

- **Connect the battery.**
- **Fill and bleed the coolant circuit according to the vehicle manufacturer's specifications.**
- **Set digital timer, teach telestart transmitter.**
- **Make settings on A/C control panel according to the "Operating Instructions for End Customer".**
- **Place the "Switch off parking heater before refuelling" signboard near the filler neck.**
- **See installation instructions for initial start-up and function test.**



Webasto Thermo & Comfort SE
Postfach 1410
82199 Gilching
Germany
Internet: www.webasto.com
Technical Extranet:
<http://dealers.webasto.com>

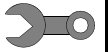

Template for Fuel Standpipe



100mm



Scale 1:1

Compare the size of the printed version with dimension lines.
Permitted tolerance a maximum of 2%.

Set the printer settings to "no margin" or "minimise margins"
and 100% of the normal size.

100mm

0

Operating Instructions for End Customer

Please remove page and add to the vehicle operating instructions.

Note:

We recommend matching the heating time to the driving time.

Heating time = driving time

Example:

For a driving time of approx. 20 min. (in one direction), we recommend not exceeding a switch-on time of 20 min.

Passenger compartment monitoring unit, if installed, must be deactivated in addition to vehicle settings for the heating operation.

For information on deactivation, please see the vehicle owner's manual.

Before parking the vehicle, make the following settings:

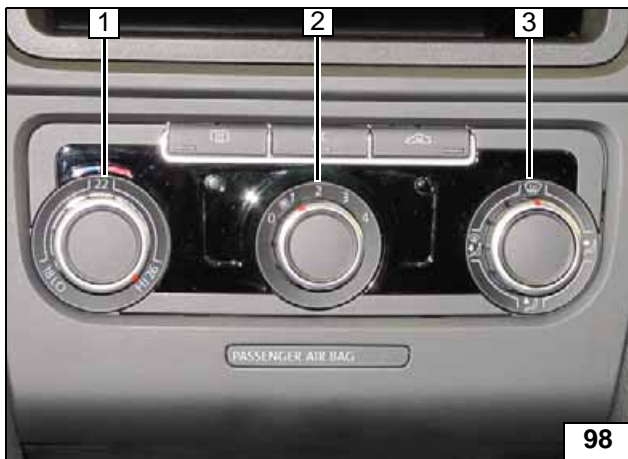

- 1 Set temperature to "max."
- 2 Fan level 1 or 2
- 3 Air outlet to windscreen

Climatic



- 1 Air outlet to windscreen
- 2 Set temperature on both sides to "HI"

Climatronic