



Water Heater

Thermo Top Evo Parking Heater



With FuelFix

Installation Documentation VW Tiguan

Validity

Manufacturer	Model	Type	EG-BE No. / ABE
VW	Tiguan	5N	e1 * 2001 / 116 * 0450 * ...

Motorisation	Fuel	Transmission type	Output in kW	Displacement in cm ³	Engine code
2.0 TDI	Diesel	DSG	81	1968	CFFD
2.0 TDI	Diesel	SG	100	1968	CFFA
2.0 TDI	Diesel	SG	103	1968	CFFB
2.0 TDI	Diesel	SG / DSG	125	1968	CFGD
1.4 TSI	Petrol	SG	90	1390	CAXA
1.4 TSI	Petrol	SG	118	1390	CAVD
2.0 TSI	Petrol	DSG	132	1984	CCZD
2.0 TSI	Petrol	DSG	147	1984	CCTA
2.0 TSI	Petrol	SG	155	1984	CCZB

SG = manual transmission
 DSG = direct gear transmission

From model year 2012
Left-hand drive vehicle

Verified equipment variants: Climatronic
 Front fog lights
 Xenon / Headlight washer system
 Front wheel drive / 4 Motion

Not verified: Climatic
 Passenger compartment monitoring

Total installation time: approx. 7.5 hours

VW Tiguan

Table of Contents

Validity	1	Preparing Installation Location	14
Necessary Components	2	Preparing Heater	16
Installation Overview	2	Installing Heater	17
Information on Total Installation Time	2	Coolant Circuit of 1.4 TSI	18
Information on Operating and Installation Instructions	3	Coolant Circuit of 2.0 TSI	19
Information on Validity	4	Coolant Circuit for Diesel Vehicle	20
Technical Information	4	Fuel	28
Explanatory Notes on Document	4	Installing FuelFix	31
Preliminary Work	5	Exhaust Gas	37
Heater Installation Location	5	Combustion Air	39
Preparing Electrical System	6	Final Work	40
Electrical System	9	FuelFix Template	41
Wiring Harness Routing	10	Operating Instructions for End Customer	42
Fan Controller	11		
Digital Timer Option	13		
Remote Option (Telestart)	13		

Necessary Components

- Basic delivery scope of Top Evo according to price list
- Installation kit with FuelFix for VW Tiguan 2012 Petrol and diesel: **1318054B**
- Heater control in accordance with price list and upon consultation with end customer
- In case of Telestart, indicator lamp in accordance with price list and in consultation with end customer

Installation instructions:

- Arrange for the vehicle to be delivered with the tank only about $\frac{1}{4}$ full.
- The installation location of the push button in case of Telestart or Thermo Call should be confirmed with the end customer.
- Depending on the space required and the manufacturer's instructions, we recommend the use of a vehicle battery with a higher electrical capacity.

Installation Overview

Legend:

1. Heater
2. Engine compartment fuse holder
3. Passenger compartment relay and fuse holder
4. Circulating pump
5. Digital Timer
6. Metering pump
7. FuelFix

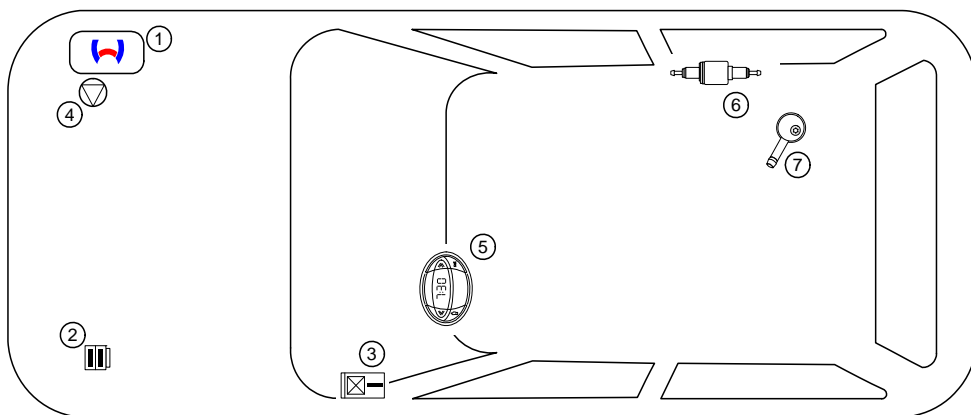

Information on Total Installation Time

The total installation time includes the time needed for mounting and demounting the vehicle-specific components, the heater specific installation time and all other times required for the system integration and initial start-up of the heater. The total installation time may vary for vehicle equipment other than provided.

Information on Operating and Installation Instructions

1 Important information (not complete)

1.1 Installation and repair



The improper installation or repair of Webasto heating and cooling systems can cause fire or the leakage of deadly carbon monoxide, leading to serious injury or death.



To install and repair Webasto heating and cooling systems you need to have completed a special company training course and have the appropriate technical documentation, special tools and special equipment.



Installation and repair may ONLY be carried out by persons trained and certified in a Webasto training course. NEVER try to install or repair Webasto heating or cooling systems if you have not completed a Webasto training course, you do not have the necessary technical skills and you do not have the technical documentation, tools and equipment available to ensure that you can complete the installation and repair work properly.

Only use genuine Webasto parts. See the Webasto air and water heaters accessories catalogue for this purpose.

1.2 Operation

To ensure safe operation, we recommend having the heater checked every two years by an authorised Webasto dealer, especially when used over a long period and/or under extreme environmental conditions.

Do not operate the heater in closed rooms due to the danger of poisoning and suffocation.

Always switch off the heater before refuelling.

The heater may only be used with the prescribed fuel diesel (DIN EN 590) or petrol (DIN EN 228).

The heater may not be cleaned with a high-pressure cleaner.

1.3 Please note

ALWAYS follow all Webasto installation and operating instructions and observe all warnings.

To become familiar with and understand all functions and properties of the heater, the operating instructions must be read carefully and observed at all times.

For proper, safe installation and repair work, the installation instructions with all warnings and safety information must be carefully read and observed at all times. Please always contact a workshop authorised by Webasto for all installation and repair work.

Important

Webasto shall assume no liability for defects, damage and injuries resulting from a failure to observe the installation, repair and operating instructions of the information contained in them.

This liability exclusion particularly applies to improper installations and repairs, installations and repairs by untrained persons or in the case of a failure to use genuine spare parts.

The liability due to culpable disregard to life, limb or health and due to damage or injuries caused by a wilful or reckless breach of duty remain unaffected, as does the obligatory product liability.

Installation should be carried out according to the general, standard rules of technology. Unless specified otherwise, fasten hoses, lines and wiring harnesses to original vehicle lines and wiring harnesses using cable ties. Insulate loose wire ends and tie back. Connectors on electronic components must audibly snap into place during assembly.

Sharp edges should be fitted with rub protection. Spray unfinished body areas, e.g. drilled holes, with anti-corrosion wax (Tectyl 100K).

Observe the instructions and guidelines of the respective vehicle manufacturer for demounting and mounting vehicle specific components!

The initial startup is to be executed with the Webasto Thermo Test Diagnosis.

When installing a programmable control module (e.g. a PWM Gateway), the corresponding settings must be checked or adjusted.

2 Statutory regulations governing installation

Guidelines	Thermo Top Evo
Heating Directive ECE R122	E1 00 0258
EMC Directive ECE R10	E1 04 5627

Note

The regulations of these guidelines are binding in the scope of the Directive 70/156/EEC and/or 2007/46/EC (for new vehicle models from 29/04/2009) and should also be observed in countries in which there are no special regulations.

Important

Failure to follow the installation instructions will result in the invalidation of the type approval for the heater and therefore invalidation of the general **homologation of the vehicle**.

Note

The heater is licensed in accordance with paragraph 19, section 3, No. 2b of the StVZO (German Road Traffic Licensing Authority).

2.1 Excerpt from ECE regulation 122 (heating system) paragraph 5 for the installation of the heater

Beginning of excerpt.

ANNEX VII

REQUIREMENTS FOR COMBUSTION HEATERS AND THEIR INSTALLATION

1. GENERAL REQUIREMENTS

1.7.1. A clearly visible tell-tale in the operator's field of view shall inform when the combustion heater is switched on or off.

2. VEHICLE INSTALLATION REQUIREMENTS

2.1. Scope

2.1.1. Subject to paragraph 2.1.2, combustion heaters shall be installed according to the requirements of this Annex.

2.1.2. Vehicles of category O having liquid fuel heaters are deemed to comply with the requirements of this Annex.

2.2. Positioning of heater

2.2.1. Body sections and any other components in the vicinity of the heater must be protected from excessive heat and the possibility of fuel or oil contamination.

2.2.2. The combustion heater shall not constitute a risk of fire, even in the case of overheating. This requirement shall be deemed to be fulfilled if the installation ensures an adequate distance to all parts and suitable ventilation, by the use of fire resistant materials or by the use of heat shields.

2.2.3. In the case of M2 and M3 vehicles, the heater must not be positioned in the passenger compartment. However, an installation in an effectively sealed envelope which also complies with the conditions in paragraph 2.2.2 may be used.

2.2.4. The label referred to in paragraph 1.4 or a duplicate, must be positioned so that it can be easily read when the heater is installed in the vehicle.

2.2.5. Every reasonable precaution should be taken in positioning the heater to minimise the risk of injury and damage to personal property.

2.3. Fuel supply

2.3.1. The fuel filler must not be situated in the passenger compartment and must be provided with an effective cap to prevent fuel spillage.

2.3.2. In the case of liquid fuel heaters, where a supply separate to that of the vehicle is provided, the type of fuel and its filler point must be clearly labelled.

2.3.3. A notice, indicating that the heater must be shut down before refuelling, must be affixed to the fuelling point. In addition a suitable instruction must be included in the manufacturer's operating manual.

2.4. Exhaust system

2.4.1. The exhaust outlet must be located so as to prevent emissions from entering the vehicle through ventilators, heated air inlets or opening windows.

2.5. Combustion air inlet

2.5.1. The air for the combustion chamber of the heater must not be drawn from the passenger compartment of the vehicle.

2.5.2. The air inlet must be so positioned or guarded that blocking by rubbish or luggage is unlikely.

2.6. Heating air inlet

2.6.1. The heating air supply may be fresh or recirculated air and must be drawn from a clean area not likely to be contaminated by exhaust fumes emitted either by the propulsion engine, the combustion heater or any other vehicle source.

2.6.2. The inlet duct must be protected by mesh or other suitable means.

2.7. Heating air outlet

2.7.1. Any ducting used to route the hot air through the vehicle must be so positioned or protected that no injury or damage could be caused if it were to be touched.

2.7.2. The air outlet must be so positioned or guarded that blocking by rubbish or luggage is unlikely.

End of excerpt.

In multilingual versions the German language is binding.

VW Tiguan

Information on Validity

The installation instructions apply to VW Tiguan Petrol and diesel vehicles - for validity, see page 1 - from model year 2012 and later, assuming technical modifications to the vehicle do not affect installation, any liability claims excluded. Depending on the vehicle version and equipment, modifications may be necessary during installation with respect to this 'installation documentation'.

Vehicle and engine types, equipment variants and other specifications not listed in this installation documentation have not been tested. However, installation according to this installation documentation may be possible.

Technical Information

Special Tools

- Hose clamp pliers for auto-tightening hose clamps
- Hose clamp pliers for Clic hose clamps of type W
- Automatic wire stripper 0.2 - 6mm²
- Crimping pliers for cable lug / tab connector 0.5 - 6mm²
- Torque wrench for 2.0 - 10 Nm
- Hose clamping pliers
- Metric thread-setter kit
- Deep-hole marker
- Webasto Thermo Test Diagnosis with current software

Dimensions

- All dimensions are in mm.

Tightening torque values

- Tightening torque values of 5x13 heater bolts and 5x11 heater stud bolts = 8Nm.
- Tightening torque value of 5x15 water connection piece retaining plate bolt = 7Nm.
- Tighten other bolt connections in accordance with manufacturer's instructions or in accordance with state-of-the-art technology.

Explanatory Notes on Document

You will find an identification mark on the outside top right corner of the page in question to provide you with a quick overview of the individual working steps.

Special features are highlighted using the following symbols:

Mechanical System



Electrical System



Coolant Circuit



Combustion Air



Fuel



Exhaust Gas



Software



Specific risk of damage to components.



Specific risk due to electrical voltage.



Specific risk of injury or fatal accidents.



Specific risk of fire or explosion.



Reference to vehicle specific documents of the manufacturer's or to the installation instructions of the Webasto components.



Reference to a special technical feature.



The arrow in the vehicle icon indicates the position on the vehicle and the viewing angle.

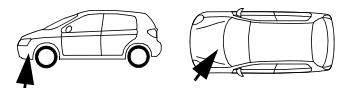

Tightening torque according to the manufacturer's vehicle-specific documents.



Preliminary Work

Vehicle



- Open the fuel tank cap.
- Ventilate the fuel tank.
- Close the fuel tank cap again.
- Depressurise the cooling system.
- Disconnect and remove the battery.
- Remove the battery carrier.
- Remove the charge-air tube.
- Remove the air filter completely, together with the intake hose.
- Remove the front underride protection.
- Remove the right front wheel.
- Remove the wheel well trim on the right-hand side.
- Remove the horn on the right.
- Remove the right rear seat.
- Loosen the right underride protection.
- Open the right-hand tank-fitting service lid.
- Remove the footwell trim on the driver's and front passenger's side.



Heater

- Remove years that do not apply from the type and duplicate label.
- Attach the duplicate label (type label) visibly in the appropriate place in the engine compartment.

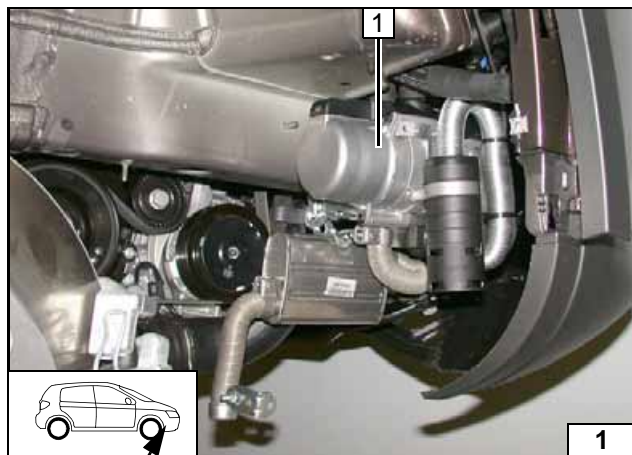

Heater Installation Location

- 1 Heater



Installation
location

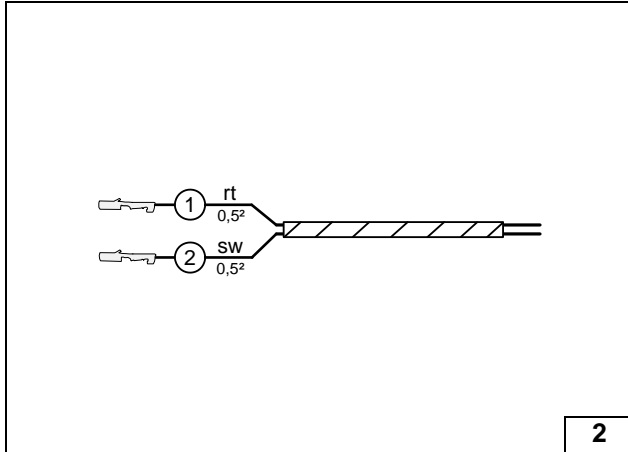
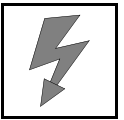

Preparing Electrical System

Wire sections retain their numbering in the entire document.

Produce all following electrical connections as shown in the wiring diagram.

- ① Red (rt) wire from wiring harness of PWM control
- ② Black (sw) wire from wiring harness of PWM control

Assigning wire

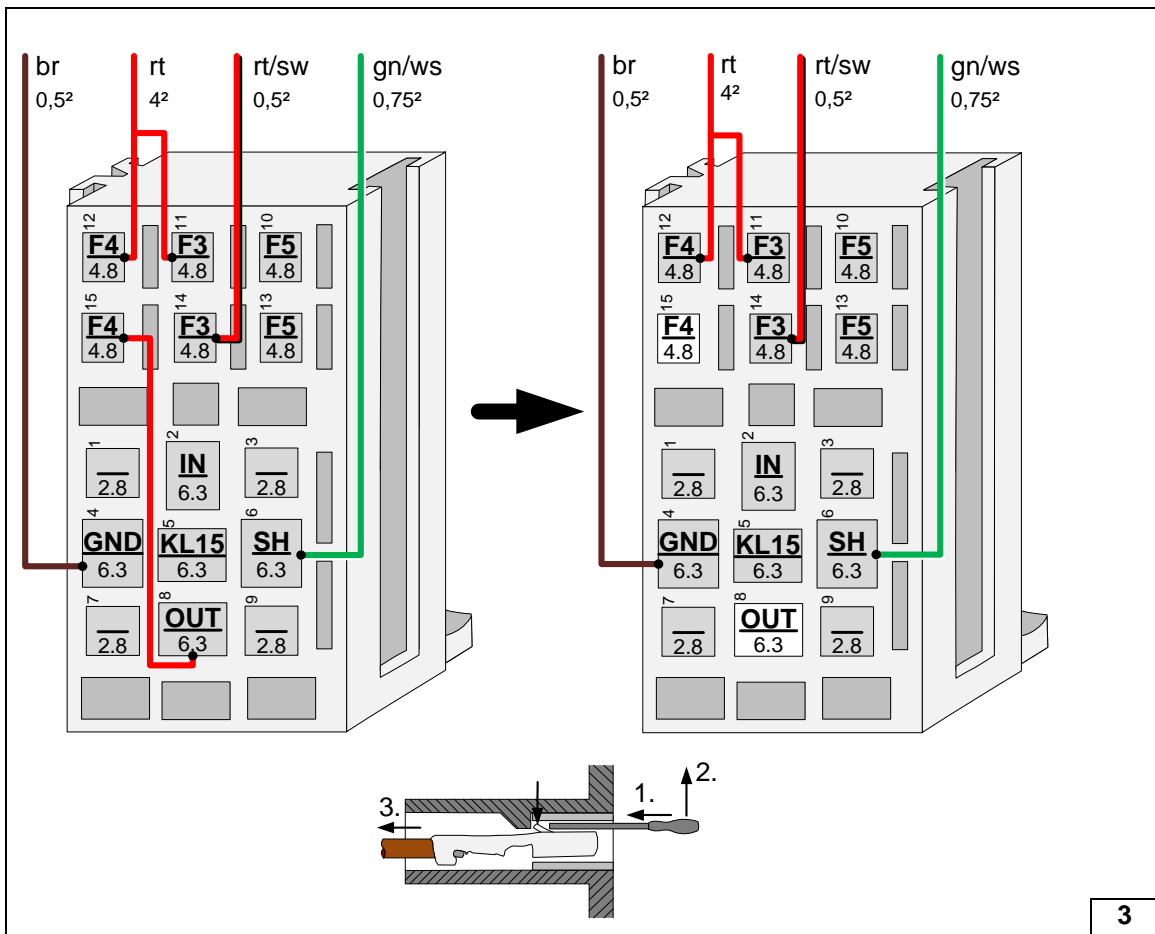

Removing red (rt) wire from passenger compartment relay and fuse holder

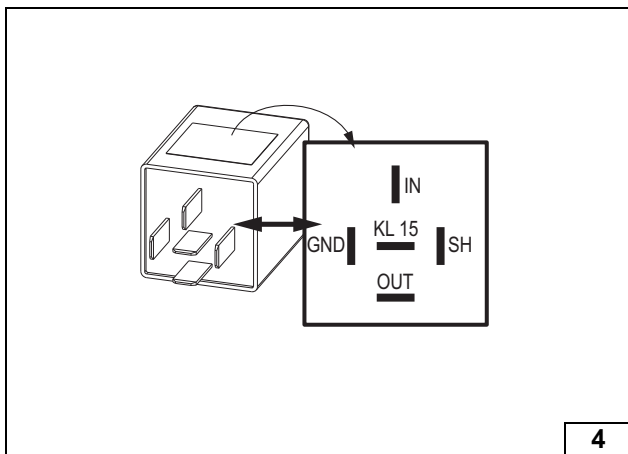

Check the PWM Gateway settings when starting up the heater and adjust if necessary.

Settings:

- Duty cycle: 30%
- Frequency: 400Hz
- Voltage: 8V
- Function: High side

View of PWM GW

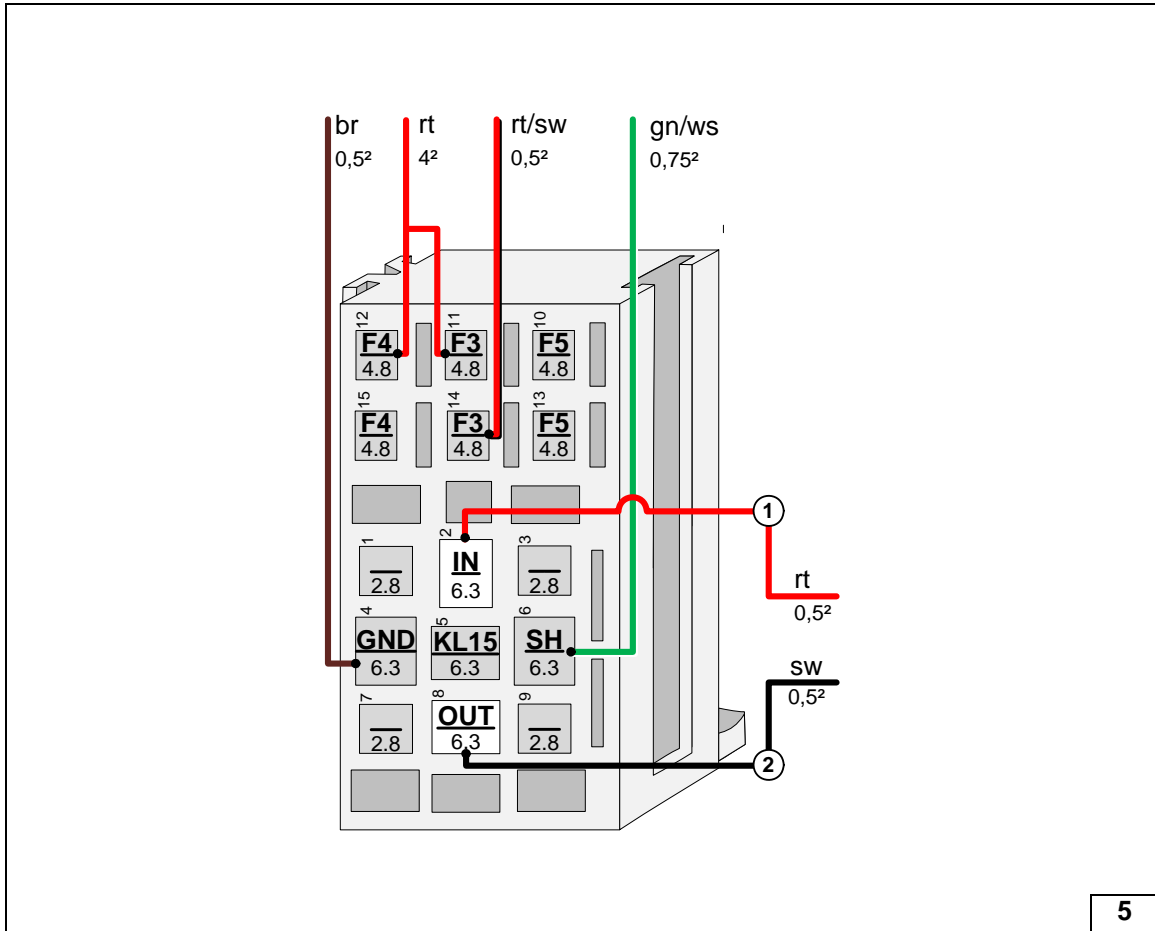

Connecting wires to passenger compartment relay and fuse holder

5

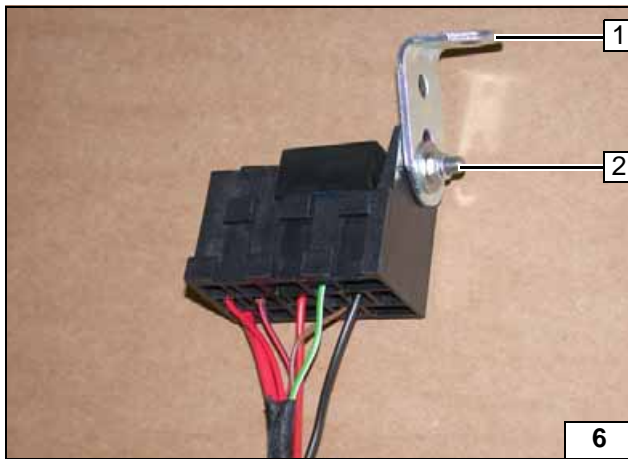

- 1 Angle bracket
- 2 M5x16 bolt, large diameter washer [2x], fuse holder, self-locking nut

Premounting passenger compartment relay and fuse holder

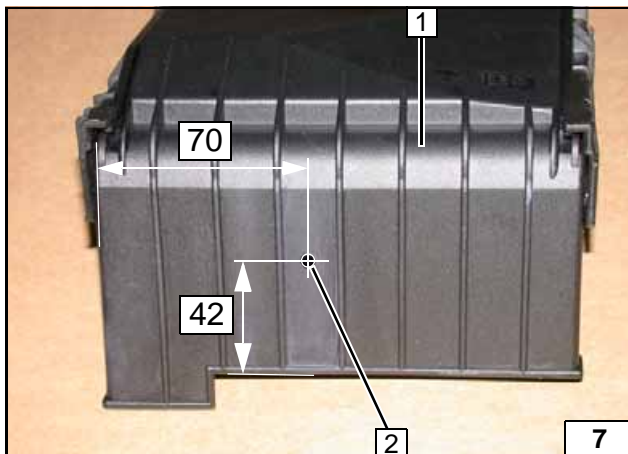

Engine compartment fuse holder

Countersink hole 2 from behind for M5 countersunk head screws.

- 1 Cover of fuse/relay carrier in engine compartment
- 2 5 mm dia. hole



Hole in cover

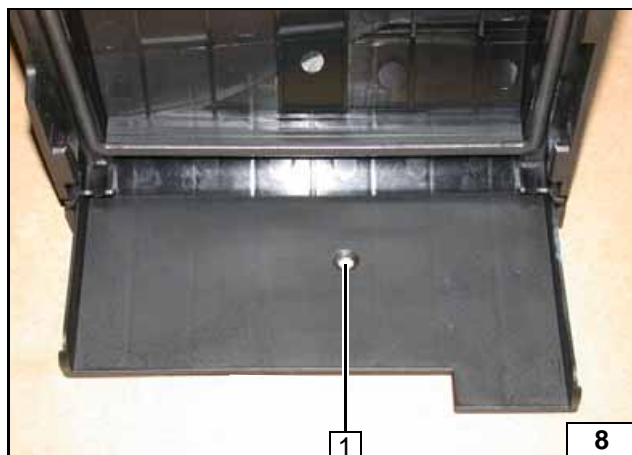

Countersink 5 mm dia. hole **1** from behind to M5 countersunk head screws.



Hole in cover

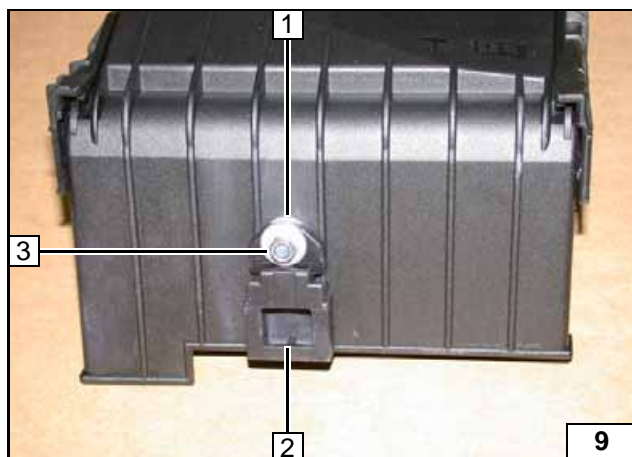

Insert large diameter washer **1** between cover of fuse and relay carrier and engine compartment fuse holder **2**.



- 3** M5x12 countersunk head screw, large diameter washer [2x], self-retaining nut

Installing engine compartment fuse holder



Electrical System



Wiring harness routing

See following page for routing.

- 1 Heater wiring harness in 10 mm dia. corrugated tube

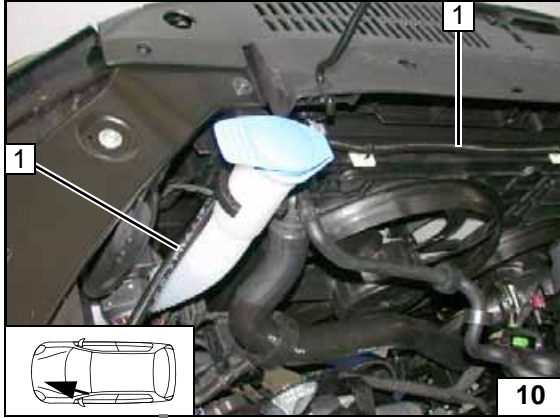

Wiring harness pass through

Detach line duct 3 and put aside.

- 1 Protective rubber plug
- 2 Heater wiring harnesses, heater control

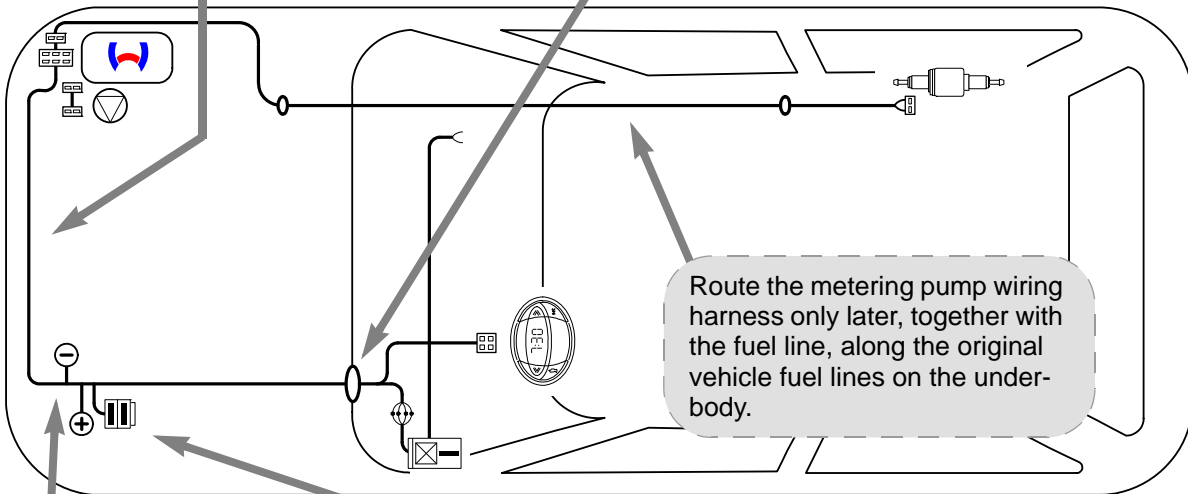
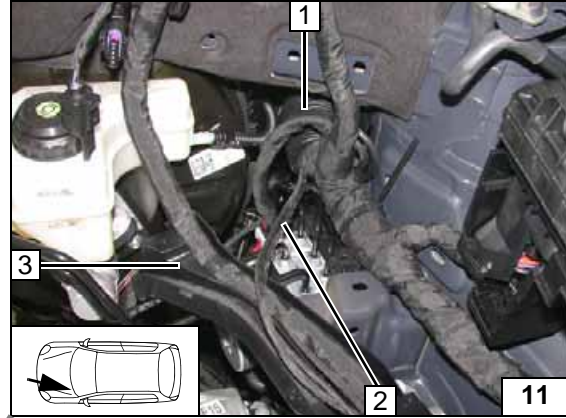

Wiring harness routing diagram

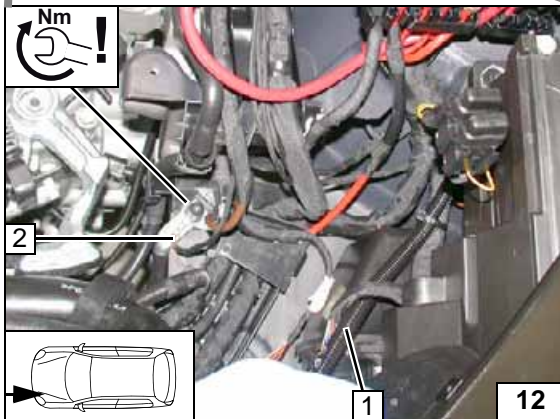

Earth wire

- 1 Heater wiring harness in 10 mm dia. corrugated tube
- 2 Earth wire on original vehicle earth point

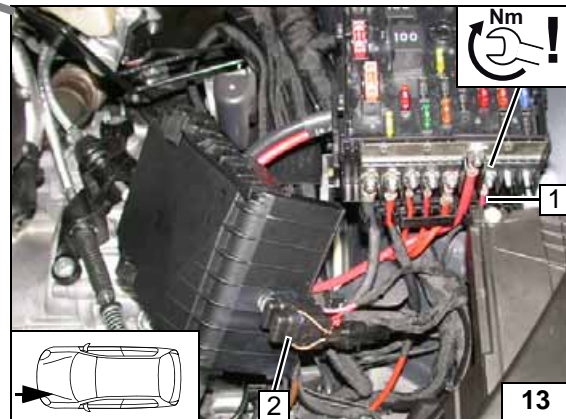

Fuse holder of engine compartment, positive wire

- 1 Positive wire on positive distributor
- 2 Fuses F1-2 inserted



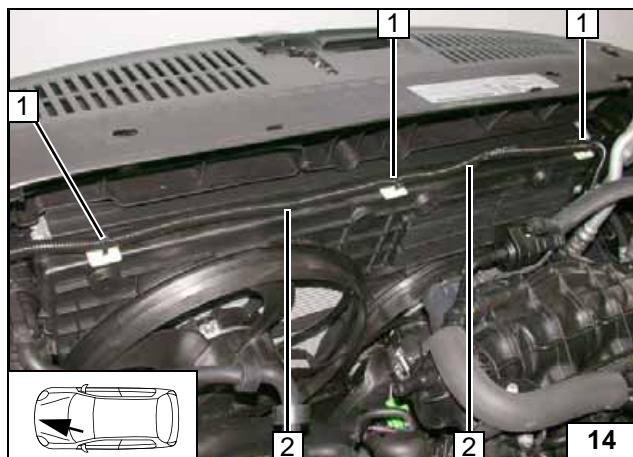

Wiring Harness Routing

Degrease adhesive area. Cut corrugated tube lengthways.

- 1 Adhesive base, cable tie [3x each]
- 2 Heater wiring harness in 10 mm dia. corrugated tube

Routing wiring harness of heater

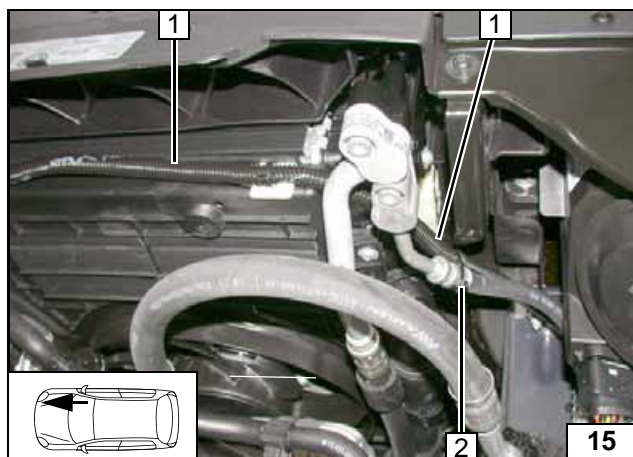

- 1 10 mm dia. heater wiring harness
- 2 Cable tie

Routing wiring harness of heater



Fan Controller

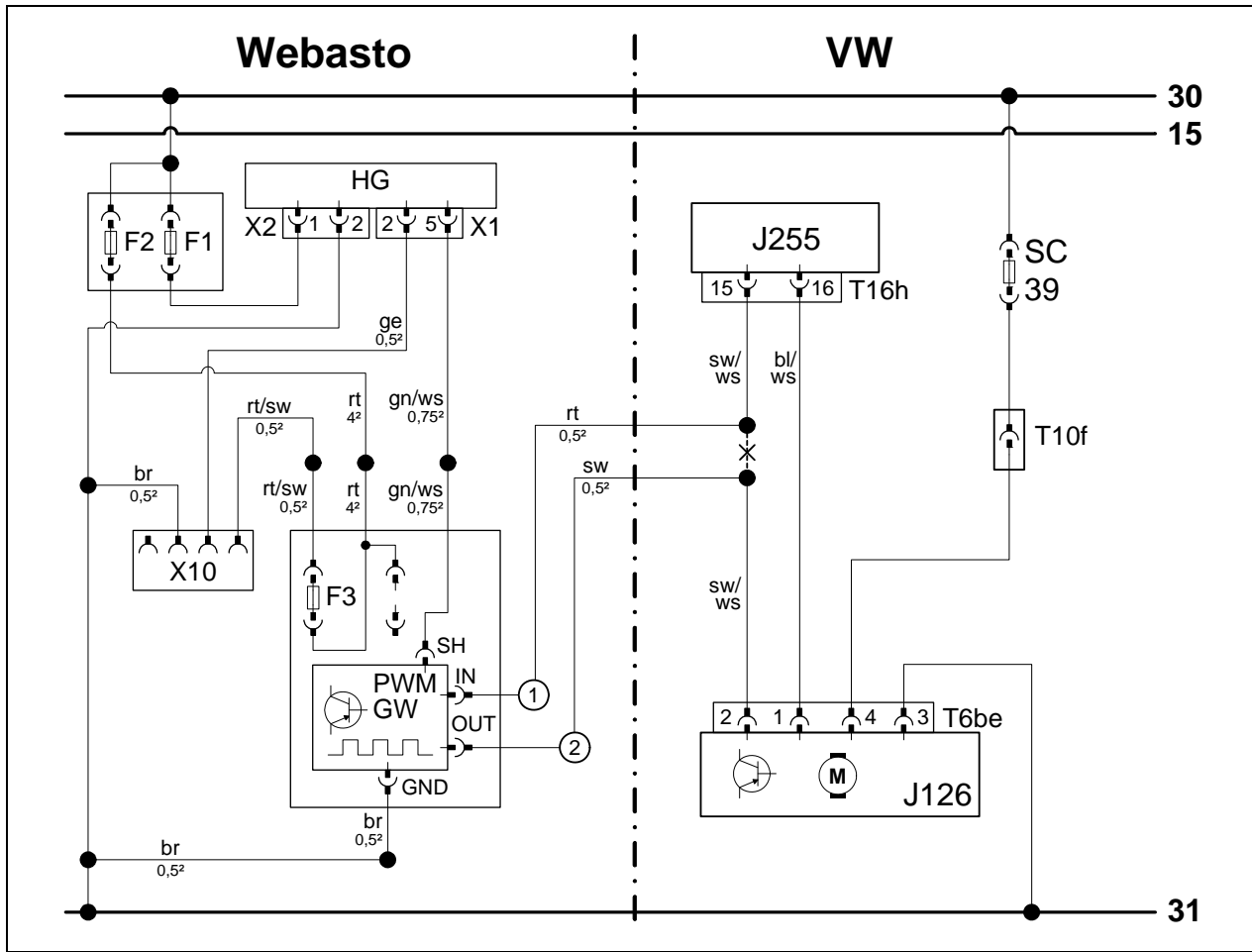

Wiring diagram

Webasto components		Vehicle components		Colours and symbols	
HG	TT-Evo heater	J255	A/C control unit	rt	red
X1	6-pin heater connector	T16h	16-pin connector J255	sw	black
X2	2-pin heater connector	SC39	40A fuse	ge	yellow
X10	4-pin connector of heater control	T10f	10-pin connector	gn	green
K1	Fan relay	J126	Fan unit	bl	blue
F1	20A fuse	T6be	6-pin connector J126	ws	white
F2	30A fuse			br	brown
F3	1A fuse				
PWM GW	Pulse width modulator				
PWM GW settings:					
Duty cycle: 30%					
Frequency: 400Hz					
Voltage: 8V				X	Cutting point
Function: High side				Wiring colours may vary.	

Legend

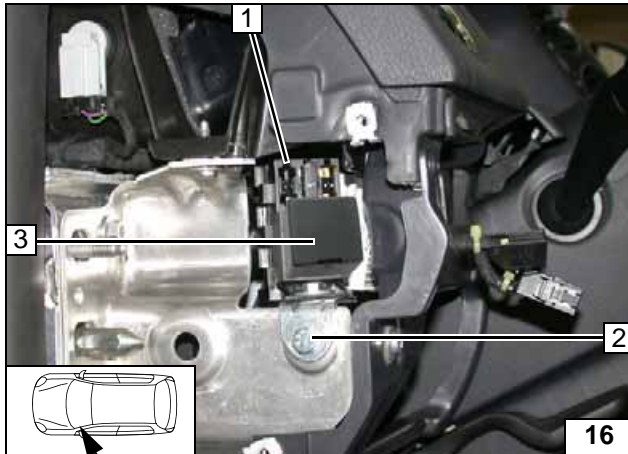
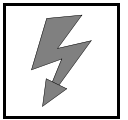

- 1 Passenger compartment relay and fuse holder
- 2 M6x20 bolt, angle bracket, existing hole, large diameter washer, flanged nut
- 3 PWM GW

Installing passenger compartment relay and fuse holder

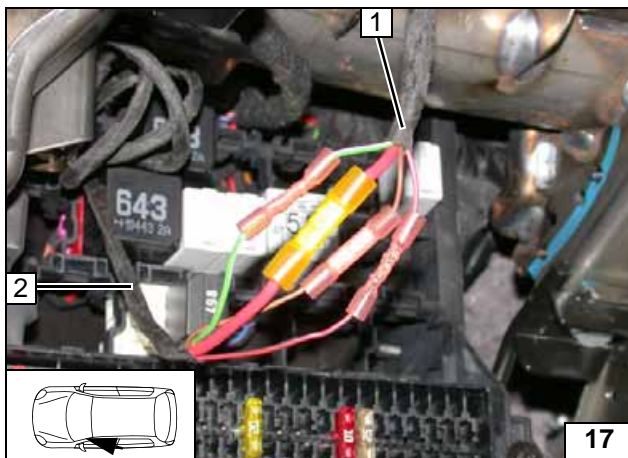

- 1 Heater wiring harness
- 2 Passenger compartment relay and fuse holder wiring harness



Connecting same colour wires of wiring harnesses

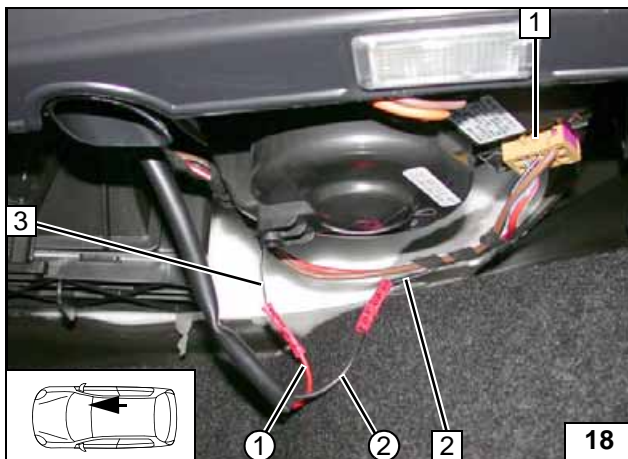

Connection to 6-pin connector T6be 1 from the fan unit.

- 2 Black/white (sw/ws) wire from 6-pin connector T6be / pin 2
- 3 Black/white (sw/ws) wire from A/C control unit
- ① Red (rt) wire from PWM GW / IN of wiring harness of PWM control
- ② Black (sw) wire from PWM GW / OUT of wiring harness of PWM control



Connecting fan unit

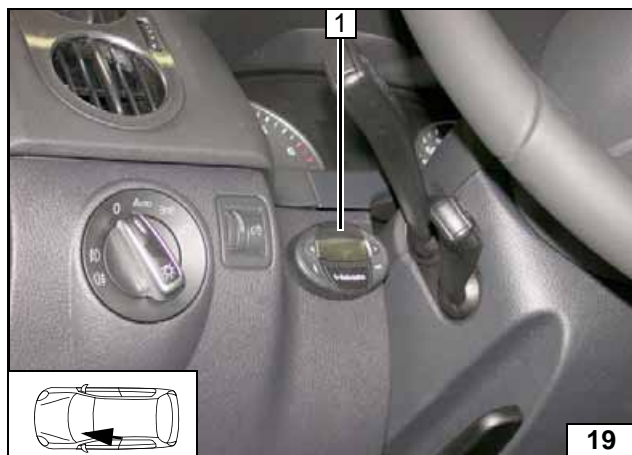

Digital Timer Option

1 Digital timer



Installing digital timer

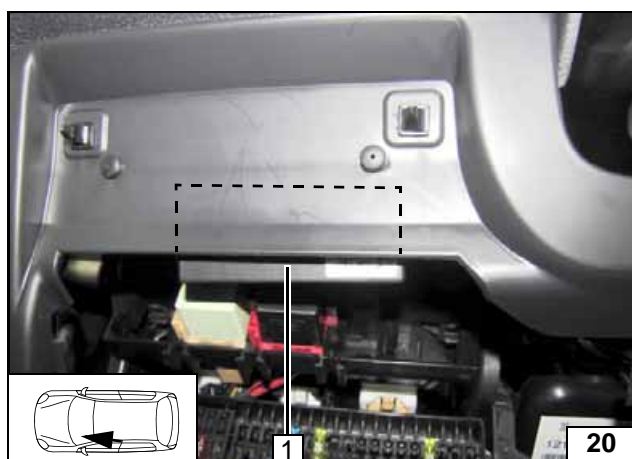

Remote Option (Telestart)

Fasten receiver 1 with adhesive tape.



Installing receiver

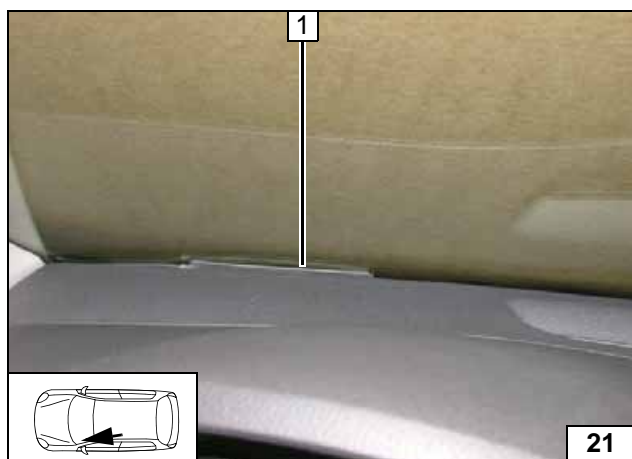

1 Aerial

Installing aerial

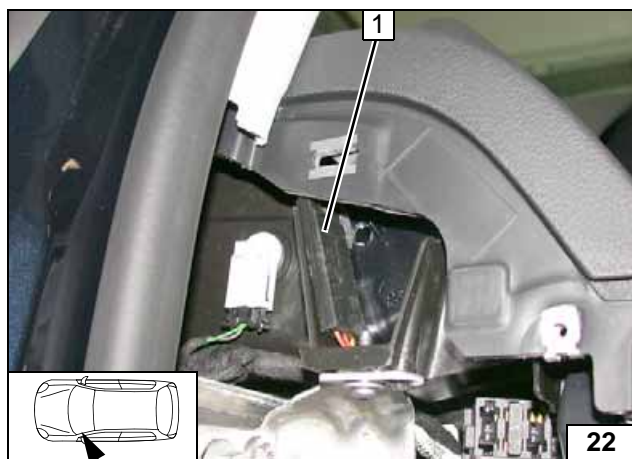

Temperature sensor T100 HTM

Fasten temperature sensor 1 with adhesive tape.



Installing temperature sensor

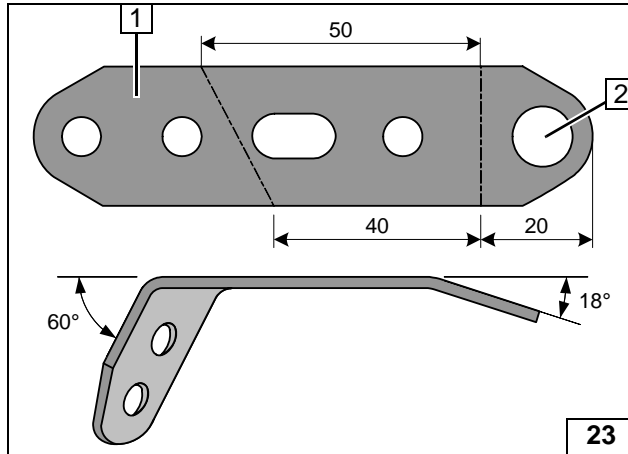
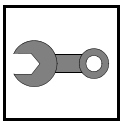

Preparing Installation Location

- 1 Perforated bracket **A**
- 2 11 mm dia. hole



Preparing perforated bracket

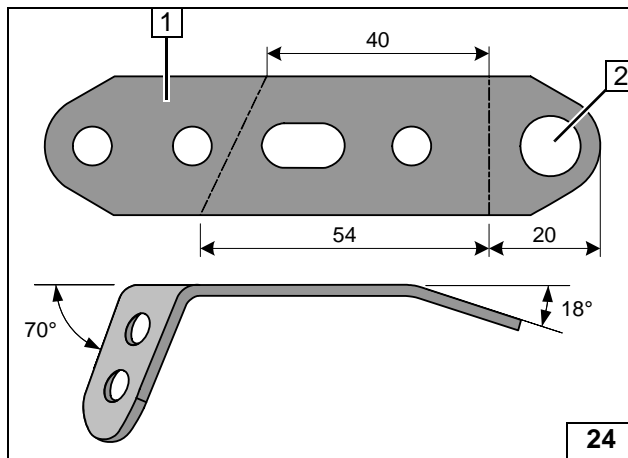

- 1 Perforated bracket **B**
- 2 11 mm dia. hole



Preparing perforated bracket

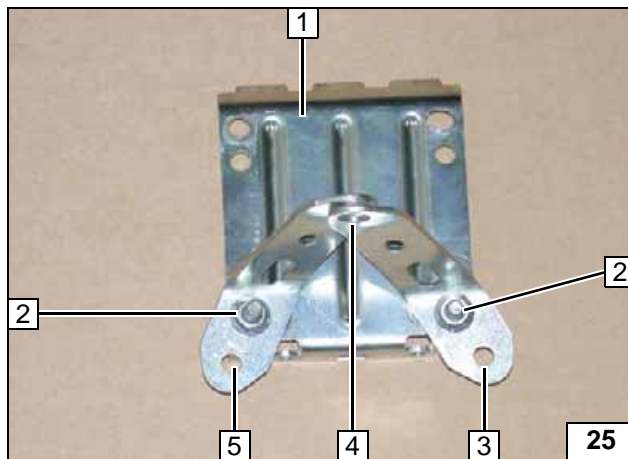

Congruently align 11 mm dia. holes of both perforated brackets at position 4.

- 1 Bracket section **A**
- 2 M6x20 bolt, loosely install flanged nut [2x each]
- 3 Perforated bracket **B**
- 5 Perforated bracket **A**



Premounting bracket

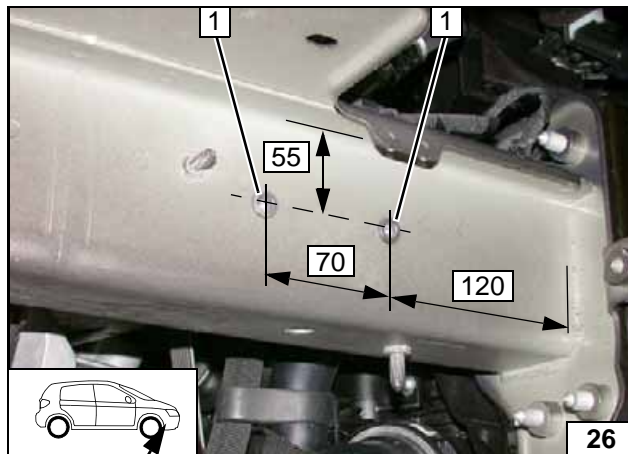

- 1 9.1 mm dia. hole; rivet nut [2x each]

Installing rivet nut

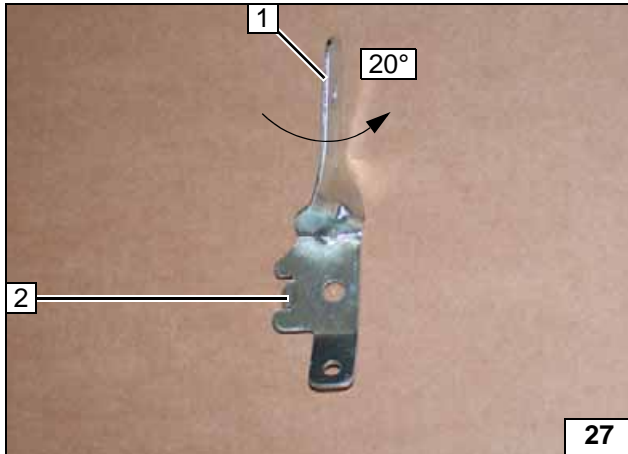
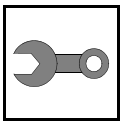

Remove horn with bracket. Twist leg 1 of bracket by 20°. Bend twist protection 2 in the opposite direction.



Preparing bracket of horn

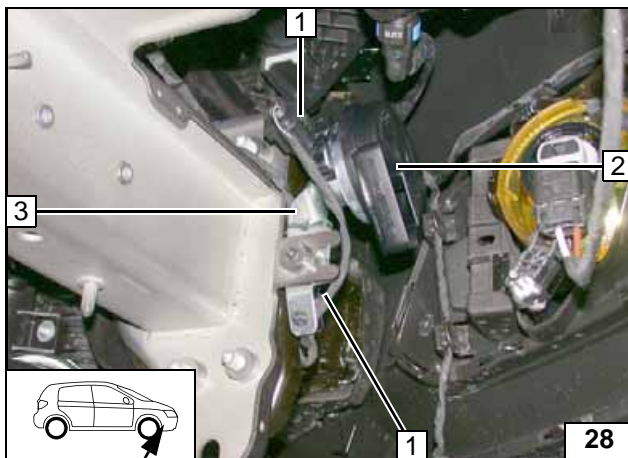

Remount horn 2. Attach and fasten wiring harness 1.



3 Bracket of horn

Installing horn

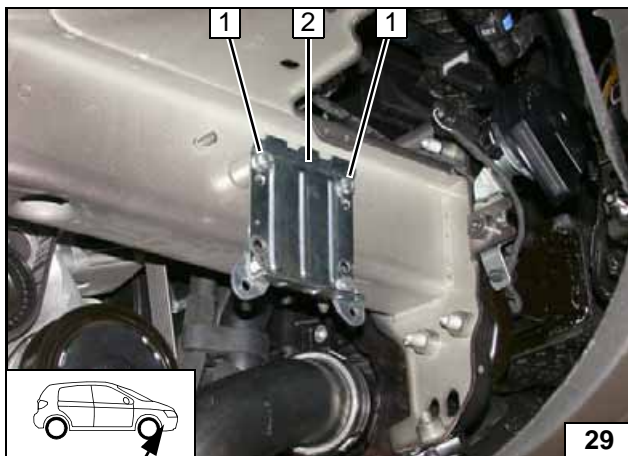

Insert one 20 mm shim each at position 1 between frame side member and bracket of section A.



- 1 M6x40 bolt, spring lockwasher, loosely mount 20 mm shim [2x each]
- 2 Bracket section A

Loosely mounting bracket section A

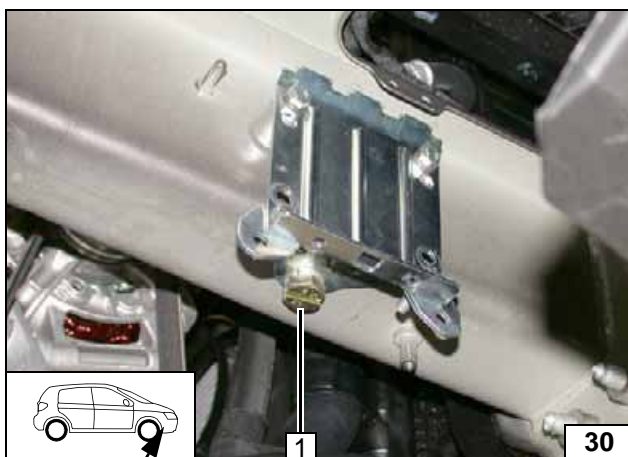

Align bracket section A, tighten all screw connections.



- 1 M10x12 bolt, spring lockwasher, existing threaded hole

Installing bracket section A

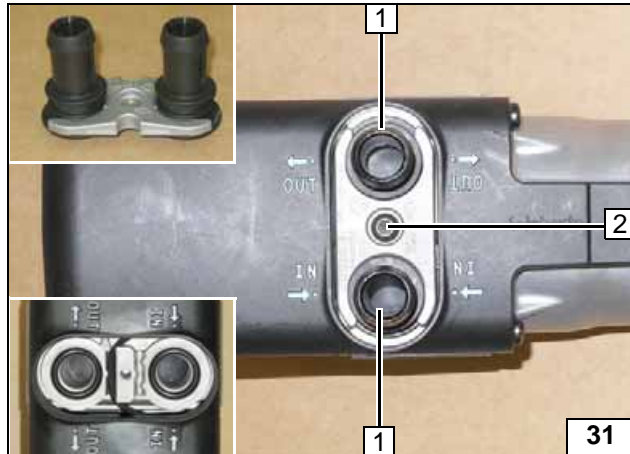
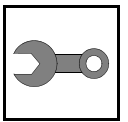

Preparing Heater

- 1 Water connection piece, sealing ring [2x each]
- 2 5x15 self-tapping bolt, retaining plate of water connection piece



Installing water connection piece

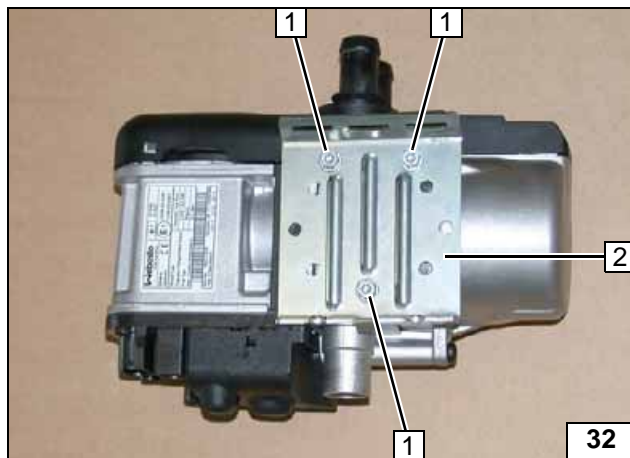

- 1 5x13 self-tapping bolt [3x]
- 2 Bracket section B

Premounting bracket section B

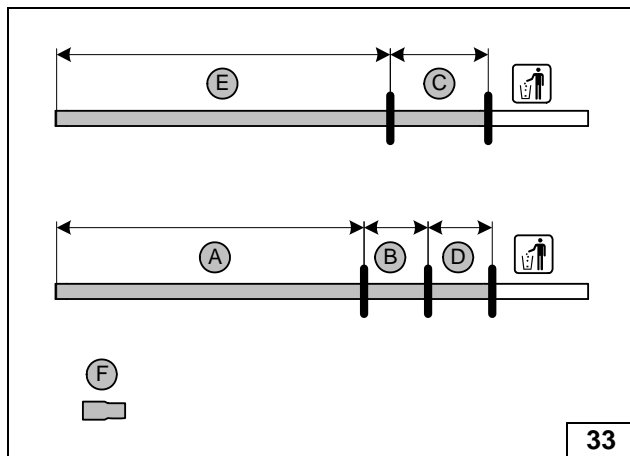

	1.4 TSI	2.0 TSI	Diesel
A=	1360	1400	1450
B=	60	60	60
C=	190	190	190
D=	60	60	60
E=	1320	1320	1380
F=	18x20 mm dia. moulded hose	18x20 mm dia. moulded hose	

Cutting hoses to length

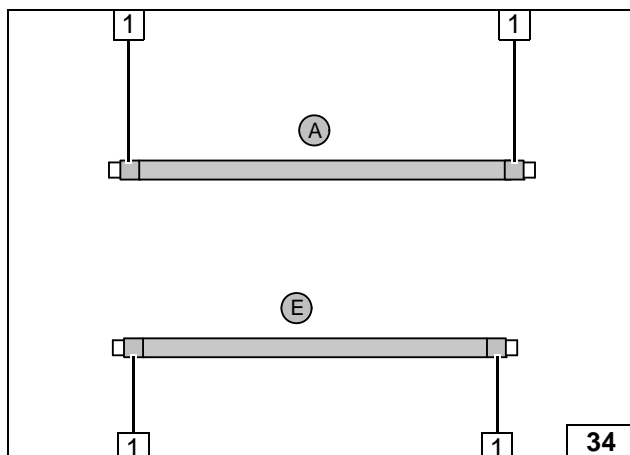

Push braided protection hose onto hoses **A** and **E** and cut to length.
Cut heat shrink plastic tubing to size.



- 1 50 mm long heat shrink plastic tubing [4x]

Preparing hoses

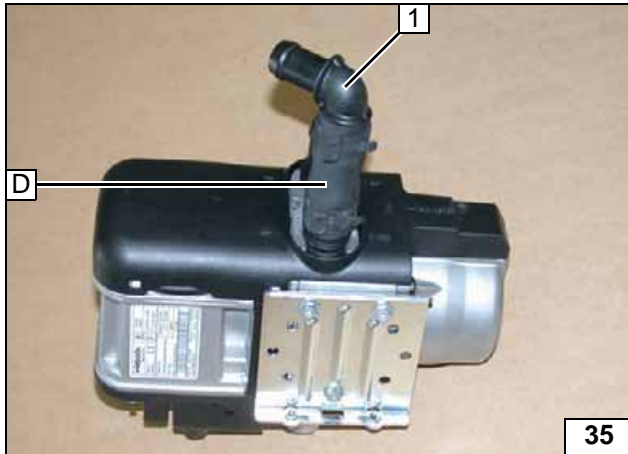
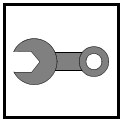

All spring clips 25 mm dia.

- 1 90°, 18x18 mm dia. connecting pipe



Premounting hose D



- 1 25 mm dia. spring clip

Premounting hose E

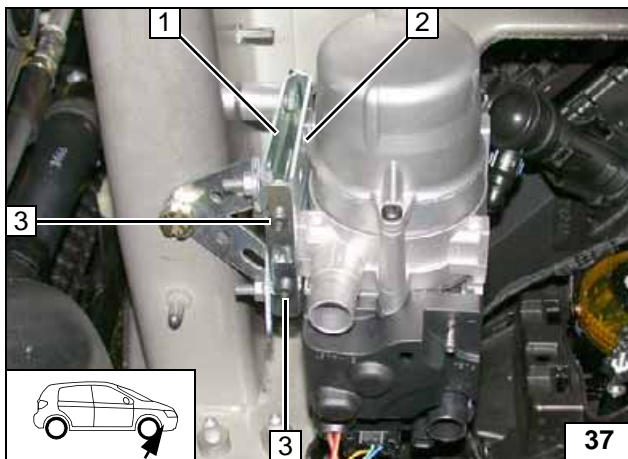

Installing Heater

Insert heater with heater section B into bracket section A.

- 1 Bracket section A
- 2 Bracket section B
- 3 5x15 self-tapping bolt [2x]



Installing heater

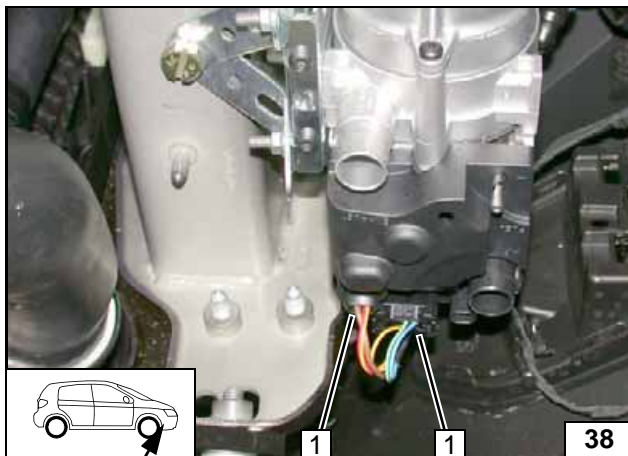

- 1 Heater wiring harness connector [2x]

Installing wiring harness



Coolant Circuit of 1.4 TSI





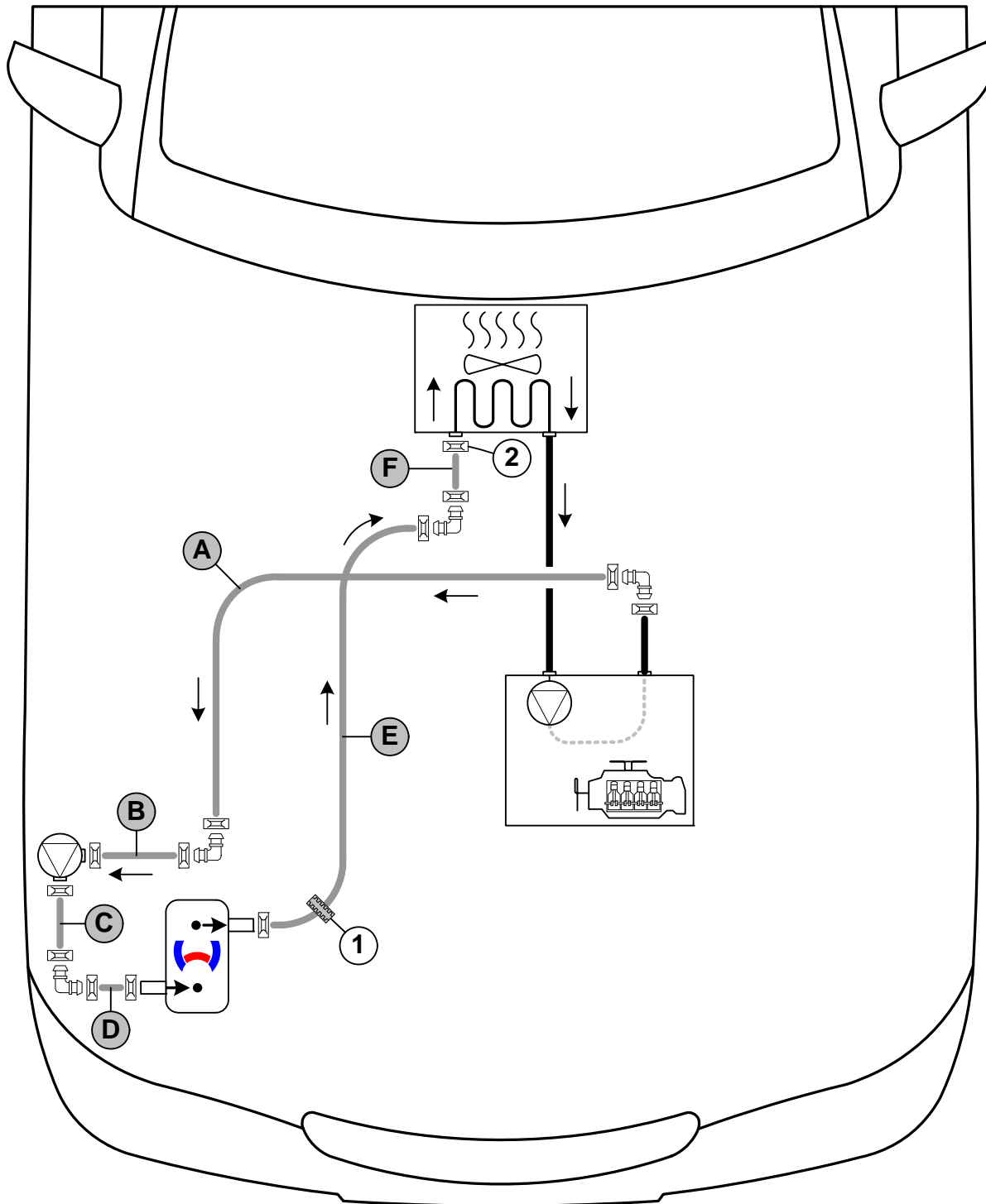

Any coolant running off should be collected in an appropriate container. Route hoses kink-free. Unless specified otherwise, always fasten using cable ties. Position clamps so that other hoses cannot be damaged. The heater must be filled with coolant when installing the hoses.

The connection should be modelled on an 'inline' circuit and based on the following diagram:



Hose routing diagram

All spring clips without a specific designation  = 25 mm dia. All connecting pipes  = 18x18 mm dia.
 1 = Black (sw) rubber isolator 
 2 = Original vehicle spring clip .





Coolant Circuit of 2.0 TSI





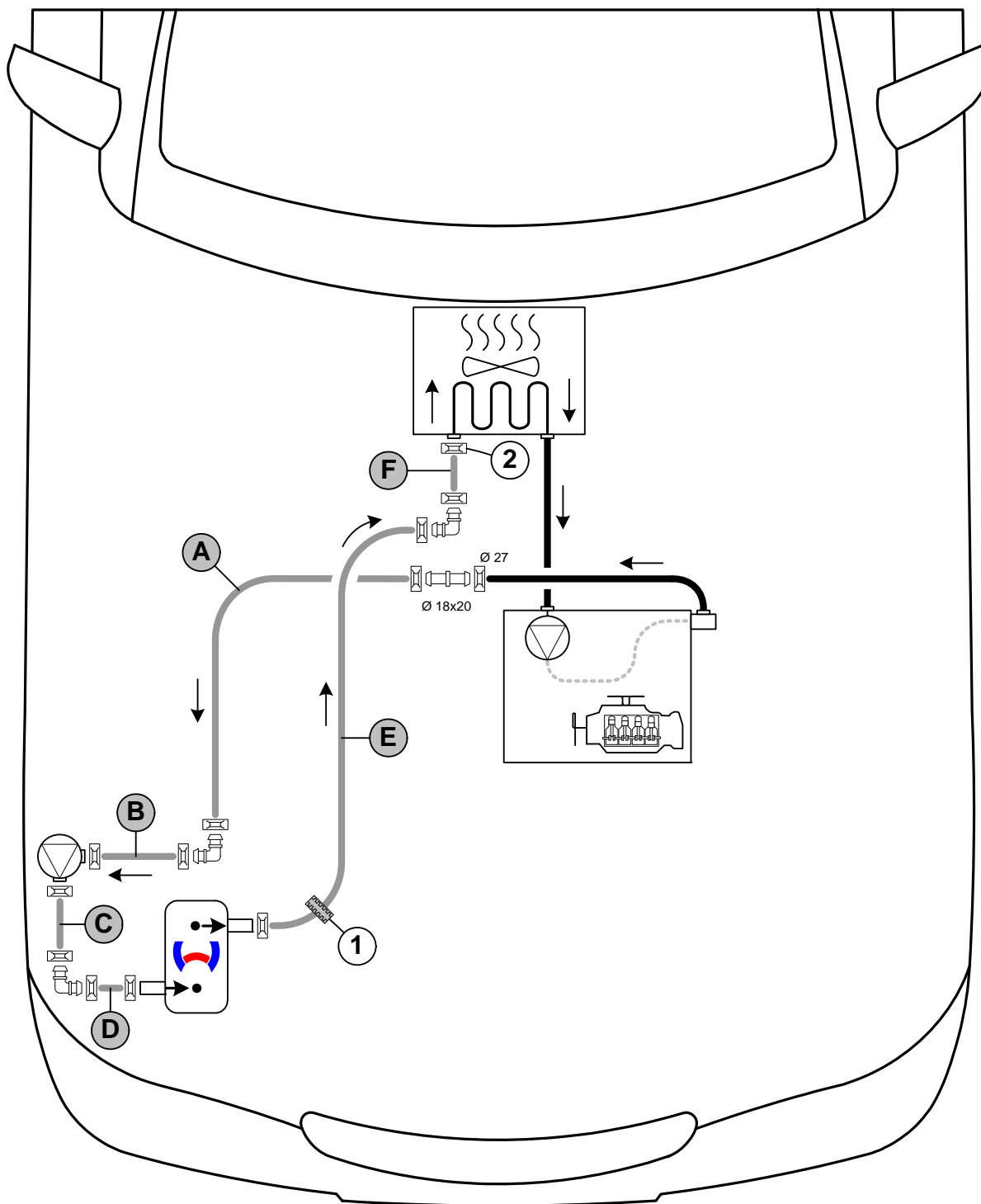

Any coolant running off should be collected in an appropriate container. Route hoses kink-free. Unless specified otherwise, always fasten using cable ties. Position clamps so that other hoses cannot be damaged. The heater must be filled with coolant when installing the hoses.

The connection should be modelled on an 'inline' circuit and based on the following diagram:



Hose routing diagram

All spring clips without a specific designation  = 25 mm dia. All connecting pipes  = 18x18 mm dia.
 1 = Black (sw) rubber isolator 
 2 = Original vehicle spring clip .





Coolant Circuit for Diesel Vehicle



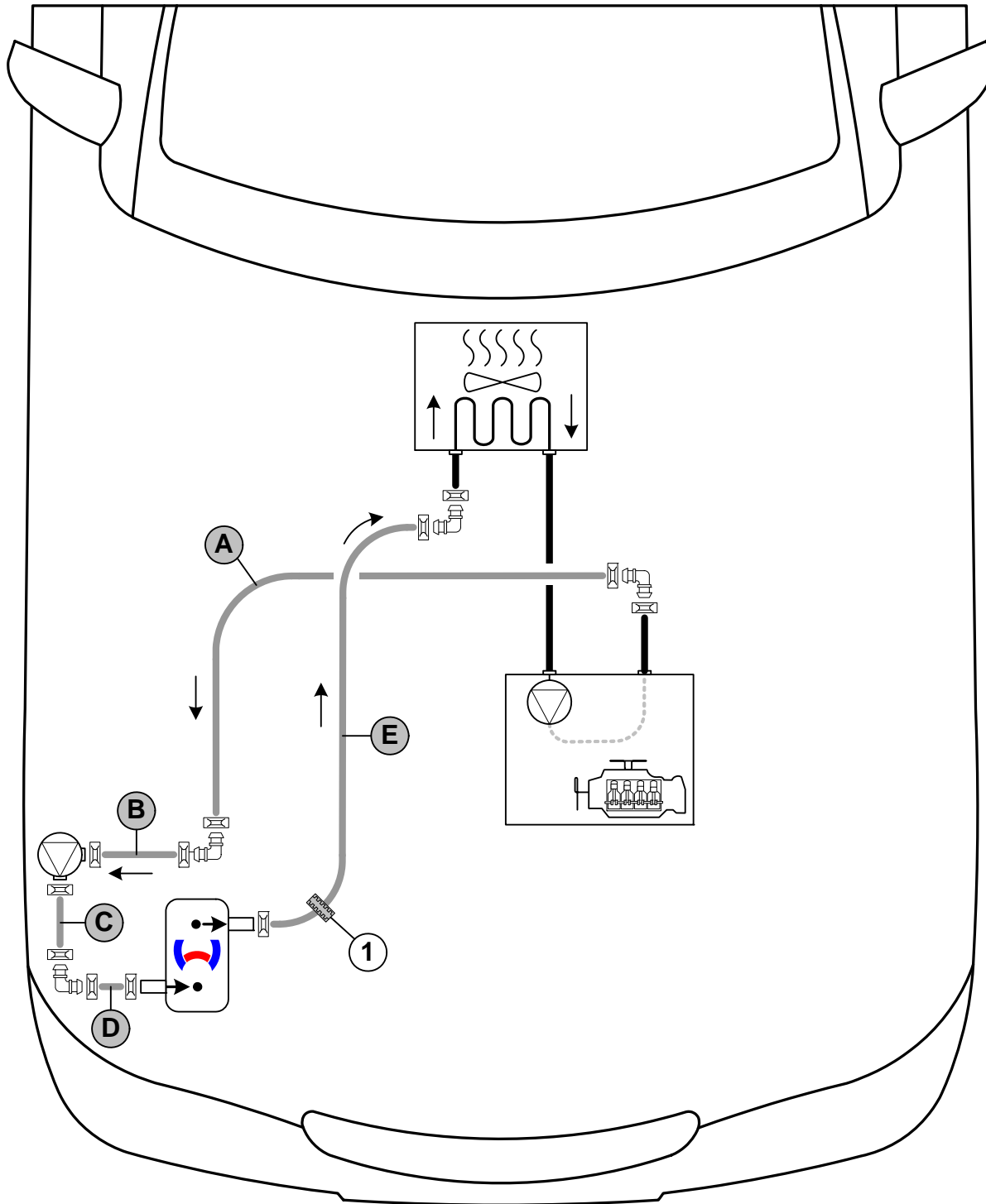

Any coolant running off should be collected in an appropriate container. Route hoses kink-free. Unless specified otherwise, always fasten using cable ties. Position clamps so that other hoses cannot be damaged. The heater must be filled with coolant when installing the hoses.

The connection should be modelled on an 'inline' circuit and based on the following diagram:



Hose routing diagram

All spring clips without a specific designation  = 25 mm dia. All connecting pipes  = 18x18 mm dia.
 1 = Black (sw) rubber isolator 



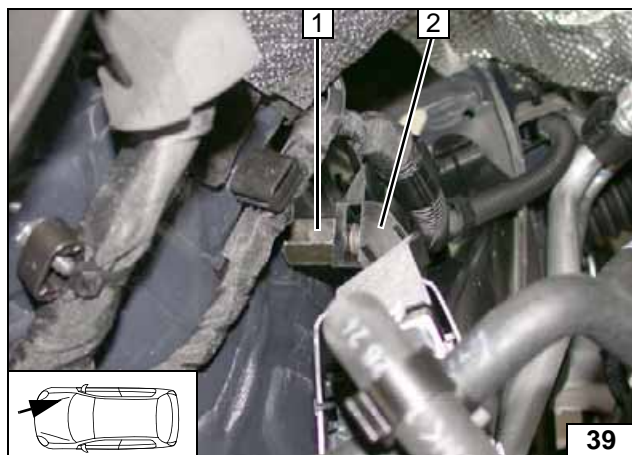

All vehicles

All the following images show a petrol vehicle. The particular work steps are nearly identical for petrol and diesel vehicles.

Detach plastic duct **2** and discard original vehicle nut.

- 1 M6x20 spacer nut, M6x12 bolt, spring lockwasher, washer [2x]

Preparing routing of hoses

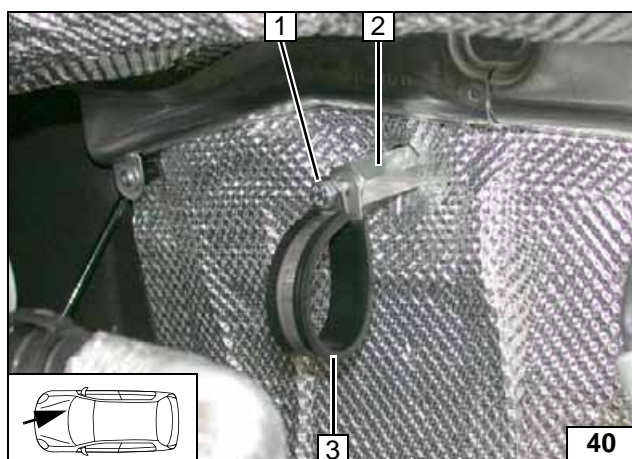

- 1 Loosely mount M6x16 bolt
- 2 M6x40 spacer nut, existing stud bolt
- 3 38 mm dia. rubber-coated p-clamp

Preparing routing of hoses

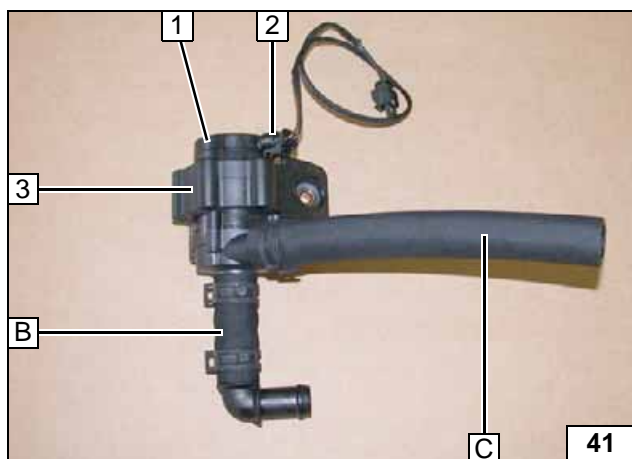

- 1 Circulating pump
- 2 Connector of circulating pump wiring harness
- 3 Circulating pump mount

Premounting circulating pump

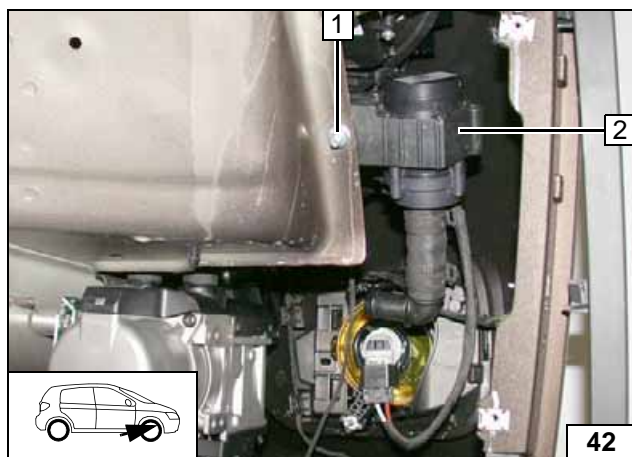

- 1 M6x20 bolt, flanged nut, existing hole
- 2 Circulating pump mount

Installing circulating pump



- 1 Connector of circulating pump wiring harness

Installing wiring harness

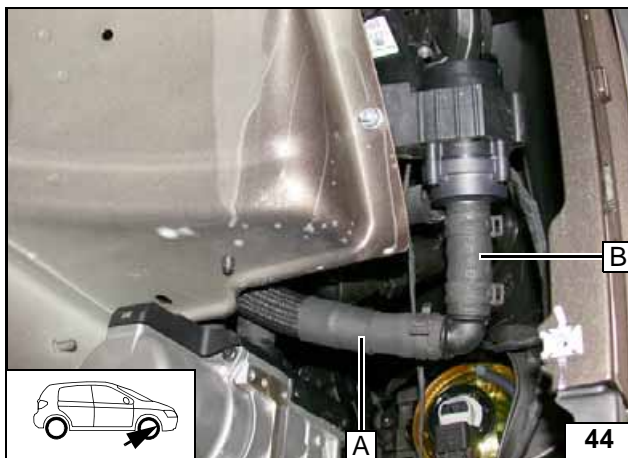

Connecting hose A and B

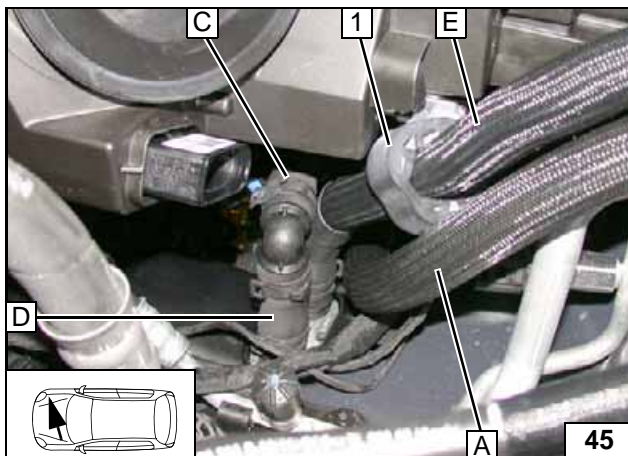

- 1 Slide on black (sw) rubber isolator and align

Routing in engine compartment

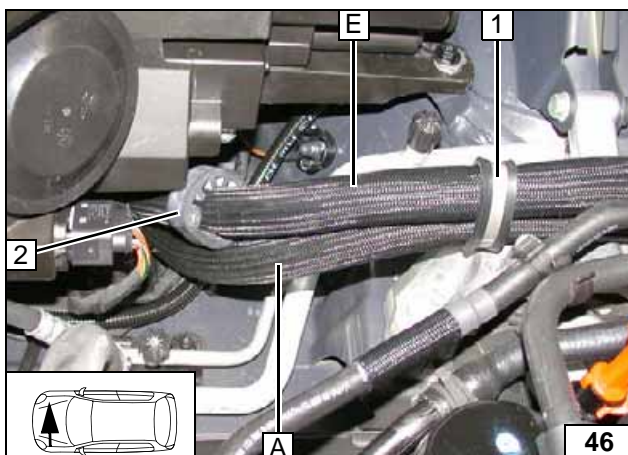

- 1 38 mm dia. rubber-coated p-clamp
- 2 Position black (sw) rubber isolator

Routing in engine compartment

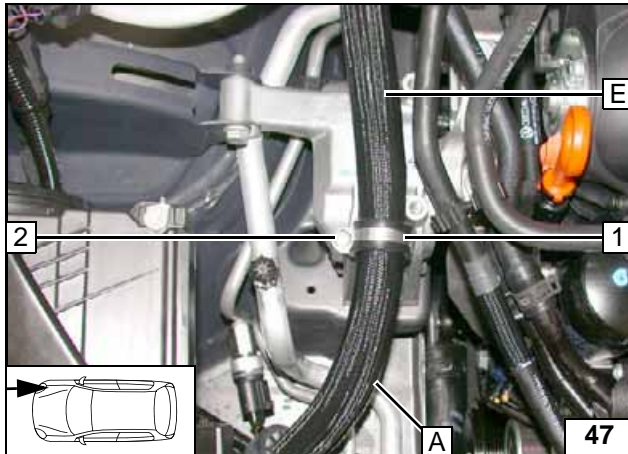

1.4 and 2.0 TSI

Hose **A** below hose **E** (hidden).

- 1 38 mm dia. rubber-coated p-clamp
- 2 M6x20 bolt, existing threaded hole



Routing in engine compartment



Routing in engine compartment

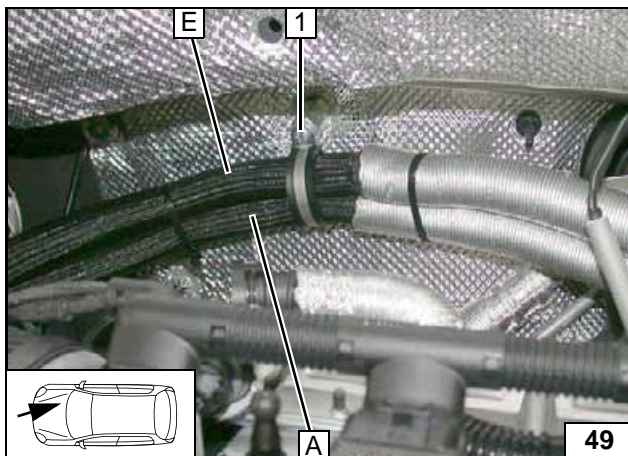

Route hose **E** and **A** through rubber-coated p-clamp. Separate heat protection hose in the centre and push one end each onto hose **E** and **A**.



- 1 Tighten M6x20 bolt

Routing in engine compartment

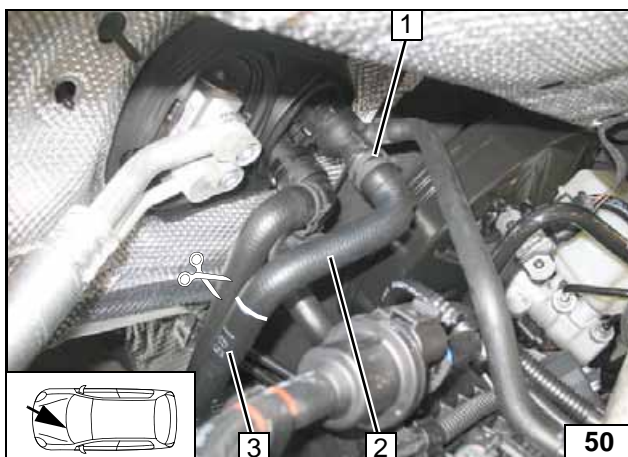

1.4 TSI

Remove heat exchanger inlet hose section **2** and discard. Spring clip **1** will be re-used.



- 3 Engine outlet hose section

Cutting point

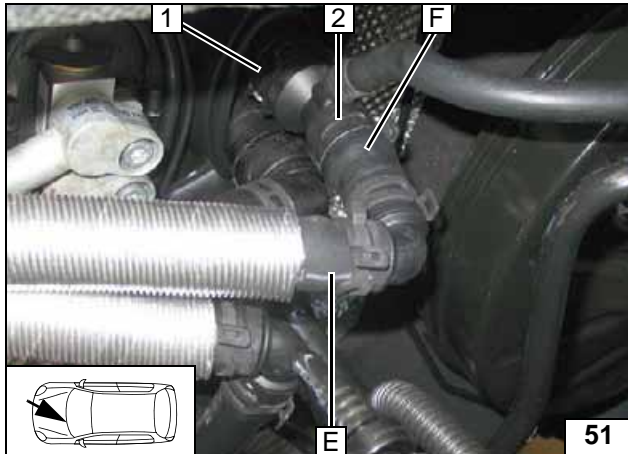

- 1 Coupling from heat exchanger inlet
- 2 Original vehicle spring clip

Connect-
ing heat ex-
changer
inlet

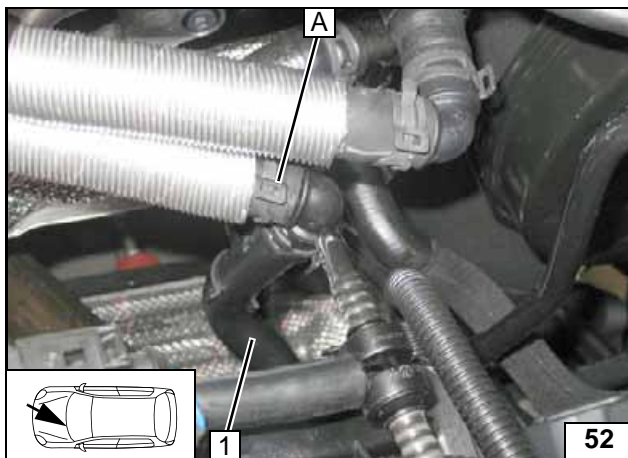

- 1 Engine outlet hose section

Connect-
ing engine
outlet



Ensure sufficient distance from neighbour-
ing components.



Aligning
hoses

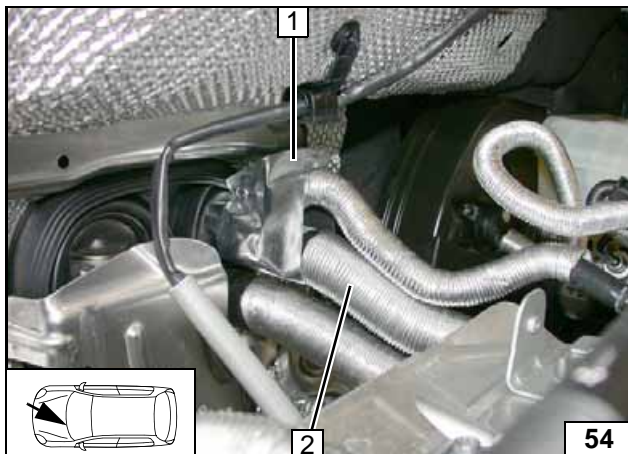

2.0 TSI

Remove protection tape 1, will be reused.
Push back heat protection hose 2 onto
hose of engine outlet / heat exchanger in-
let.



Cutting
point

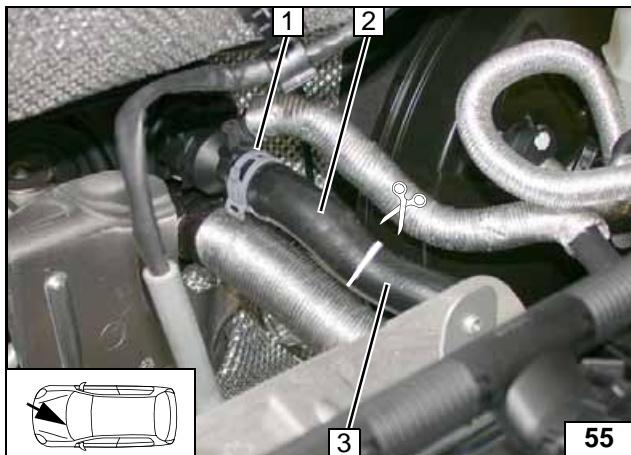

Remove heat exchanger inlet hose section 2 and discard. Spring clip 1 will be re-used.



3 Engine outlet hose section

Cutting point

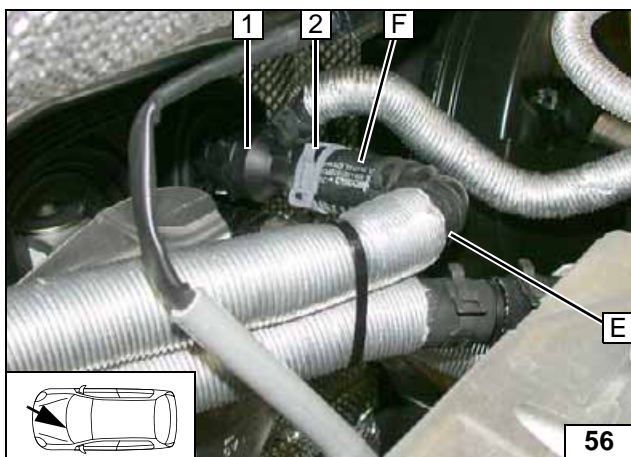

1 Coupling from heat exchanger inlet
2 Original vehicle spring clip

Connect-
ing heat ex-
changer
inlet

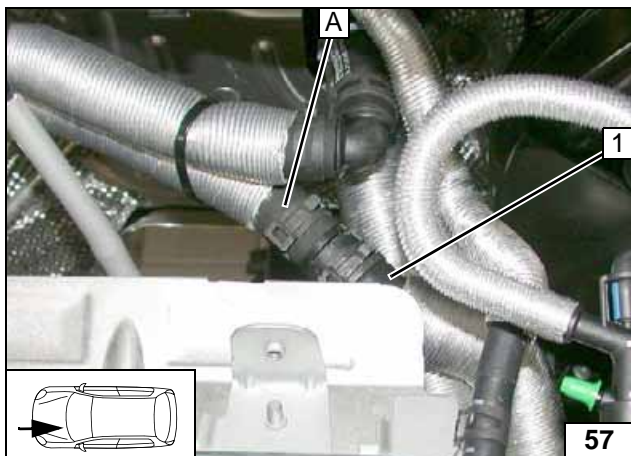

1 Engine outlet hose section

Connect-
ing engine
outlet

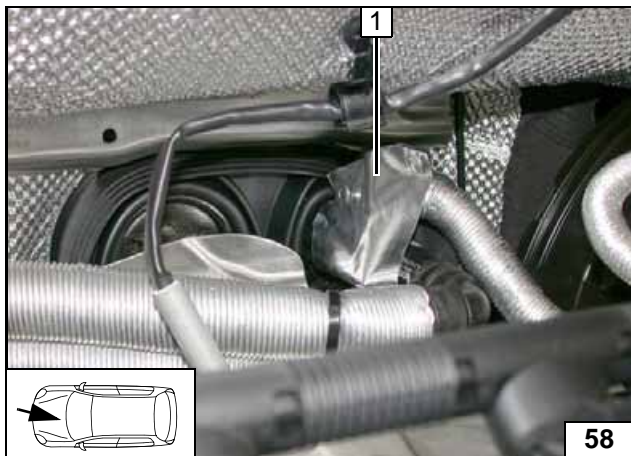

Remount protection tape 1. Align hoses. Ensure sufficient distance from neighbouring components.



Mounting
protection
tape

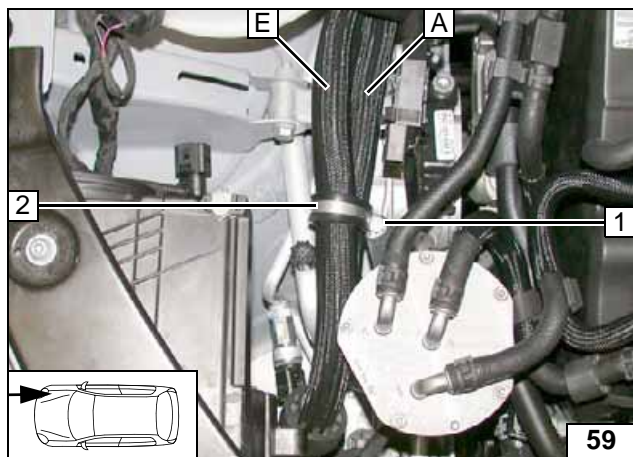

Diesel

- 1 M6x20 bolt, existing threaded hole
- 2 38 mm dia. rubber-coated p-clamp

Routing in engine compartment



Routing in engine compartment

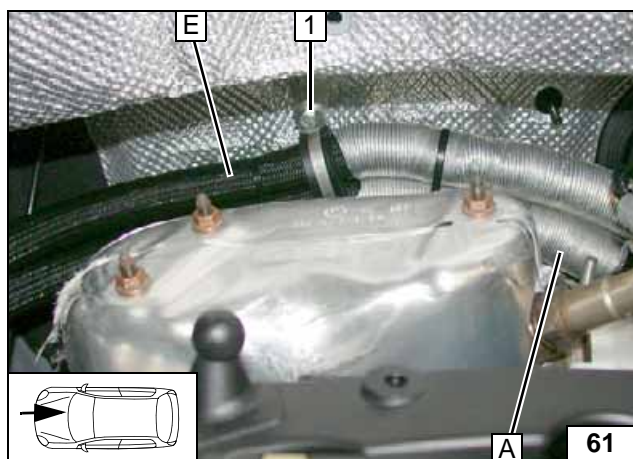

Route hose **E** and **A** through rubber-coated p-clamp. Separate heat protection hose in the centre and push one end each onto hose **E** and **A**.



- 1 Tighten M6x20 bolt

Routing in engine compartment

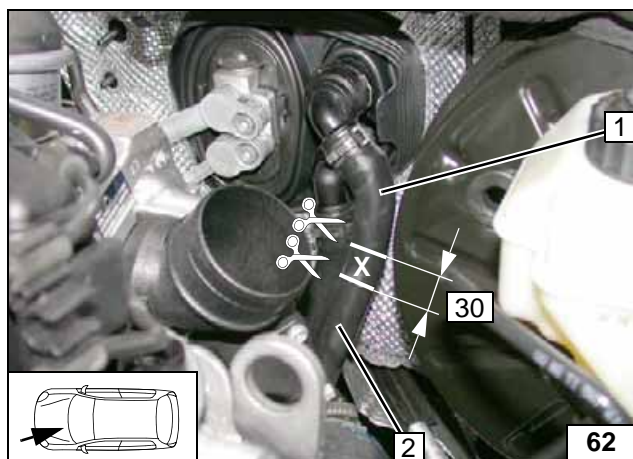

- 1 Hose section of heat exchanger inlet
- 2 Engine outlet hose section



X = 

Cutting point

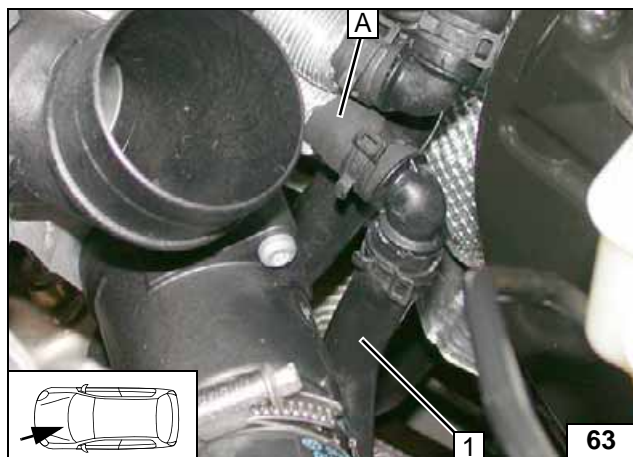

1 Engine outlet hose section

Connect-
ing engine
outlet

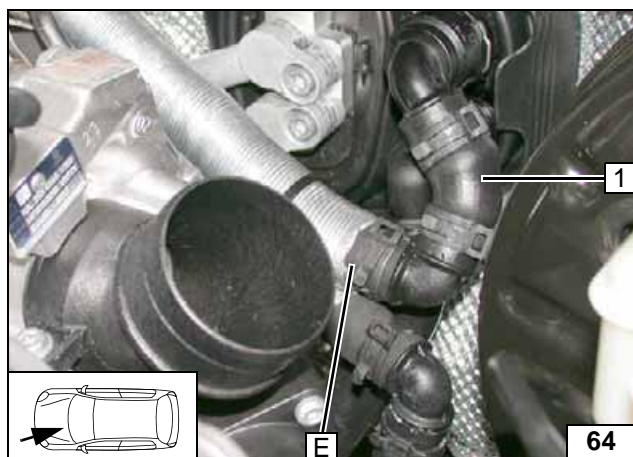

Align hoses. Ensure sufficient distance from neighbouring components.



1 Hose section of heat exchanger inlet

Connect-
ing heat ex-
changer
inlet

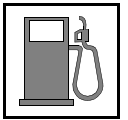

Fuel



Open the vehicle's fuel tank cap, ventilate the tank and then re-close the fuel tank cap.

Catch any fuel running off in an appropriate container.

Route fuel line and metering pump wiring harness so that they are protected against stone impact. Unless specified otherwise, always fasten using cable ties.



Provide rub protection for fuel line and wiring harness in areas where there are sharp edges.

The fuel line and wiring harness are routed to the metering pump as shown in the wiring harness routing diagram.

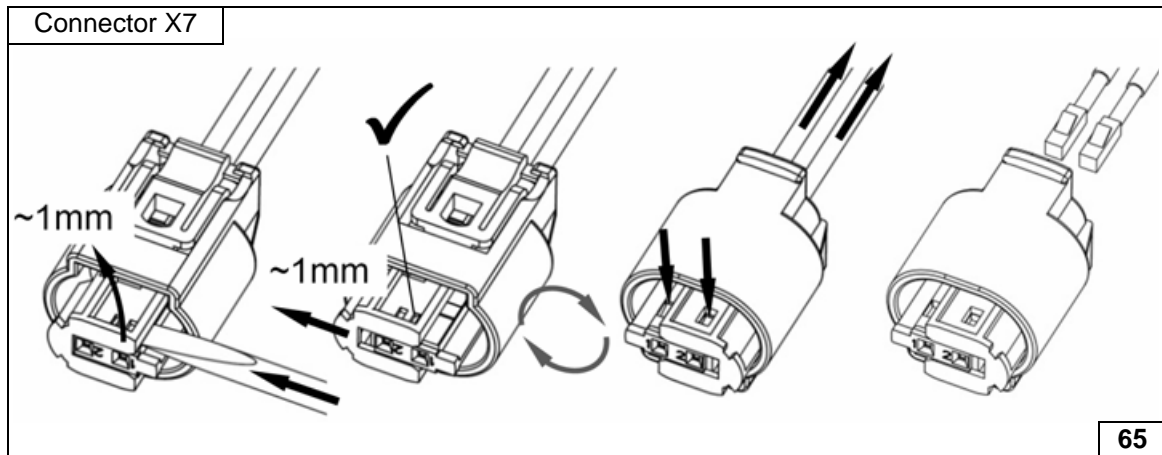

Dismantling metering pump connector

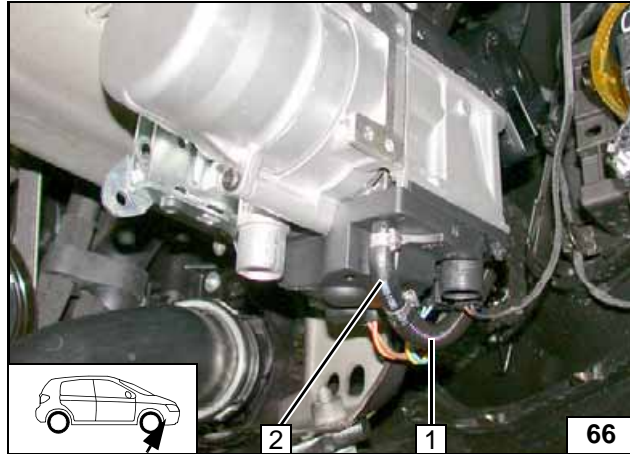

Pull fuel line and metering pump wiring harness into 10 mm dia. corrugated tube 1.

2 90° moulded hose, 10mm dia. clamp [2x]

Connecting heater

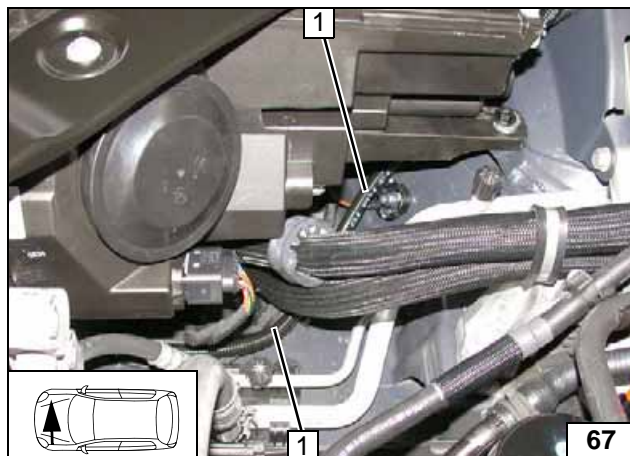

1 Fuel line, metering pump wiring harness in 10 mm dia. corrugated tube

Routing lines

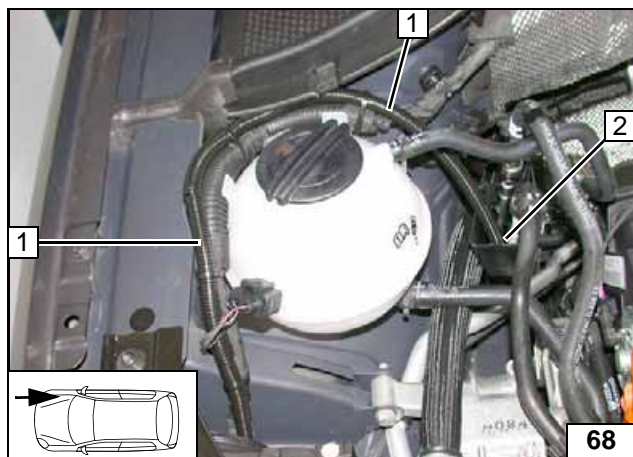

Cut corrugated tube on cable duct 2 to length. Route fuel line and metering pump wiring harness to underbody through cable duct 2.

- 1 Fuel line, metering pump wiring harness in 10 mm dia. corrugated tube



Routing lines

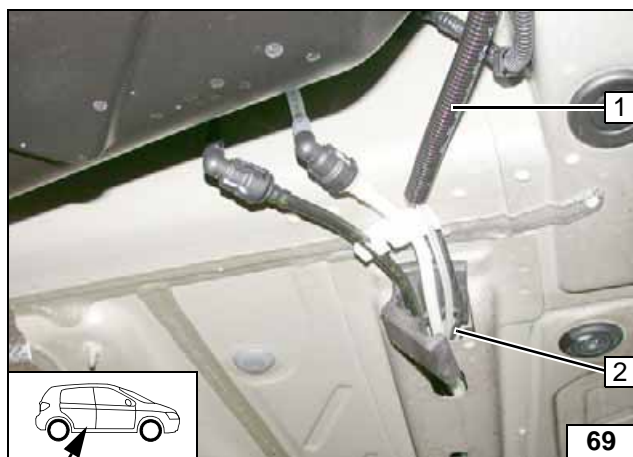

Lead fuel line and metering pump wiring harness out of cable duct 2 and pull them into 10 mm dia. corrugated tube 1.

- 1 Fuel line, metering pump wiring harness in 10 mm dia. corrugated tube



Routing lines

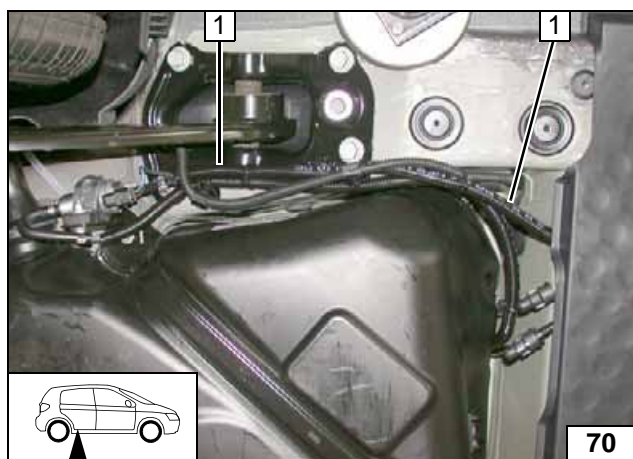

- 1 Angle bracket



Routing lines

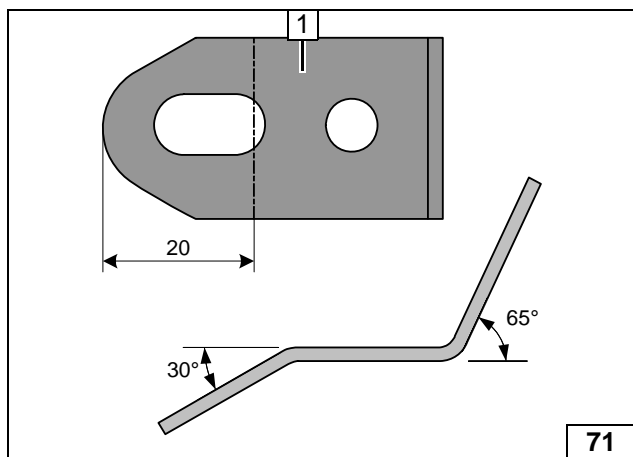

Preparing angle bracket

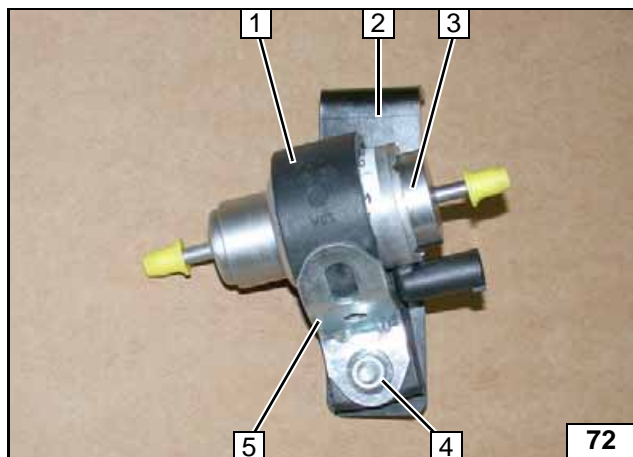

- 1 Metering pump mount
- 2 Metering pump bracket
- 3 Metering pump
- 4 M6x25 bolt, flanged nut
- 5 Angle bracket

Premounting metering pump

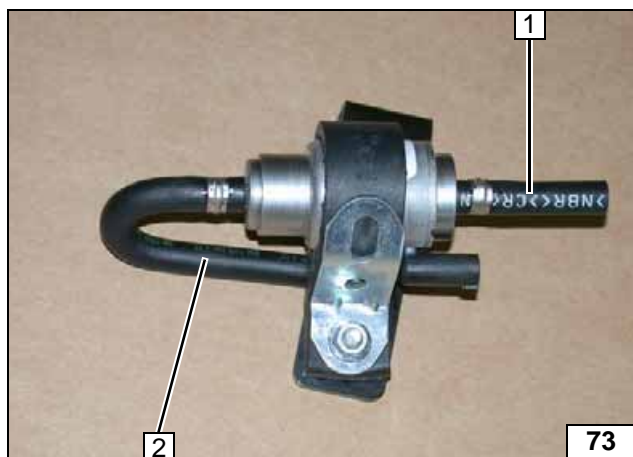

- 1 Hose section, 10 mm dia. clamp
- 2 180° moulded hose, 10 mm dia. clamp

Premounting metering pump

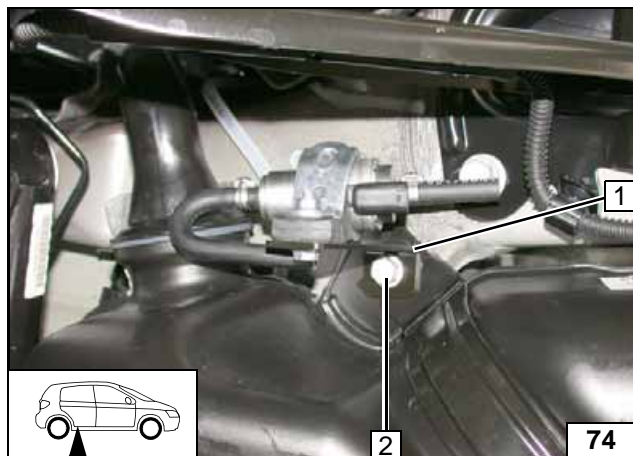

- 1 Metering pump bracket
- 2 Original vehicle bolt



Installing metering pump

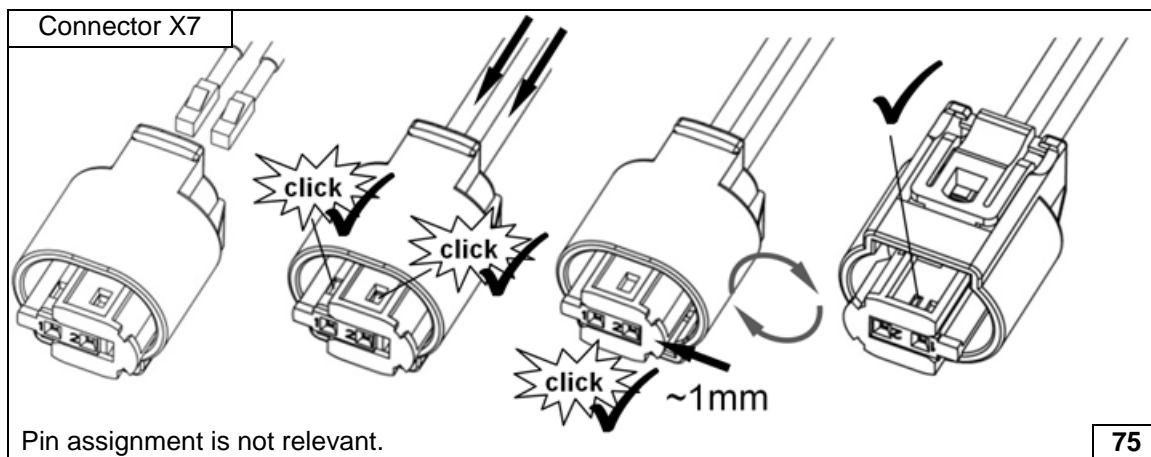

Completing metering pump connector

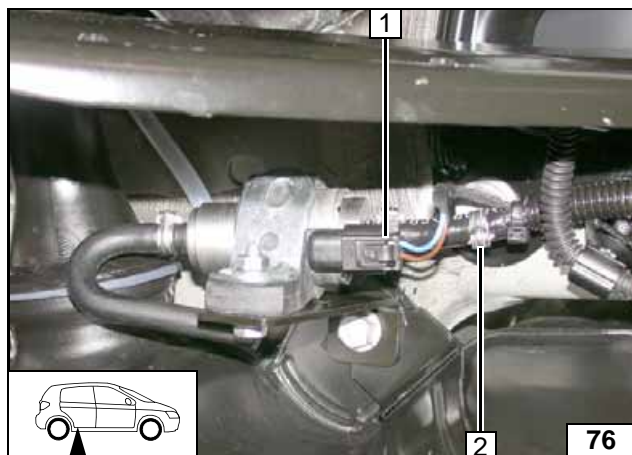
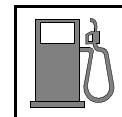

- 1 Metering pump wiring harness, connector X7 mounted
- 2 Fuel line, 10 mm dia. clamp

Connect-
ing meter-
ing pump

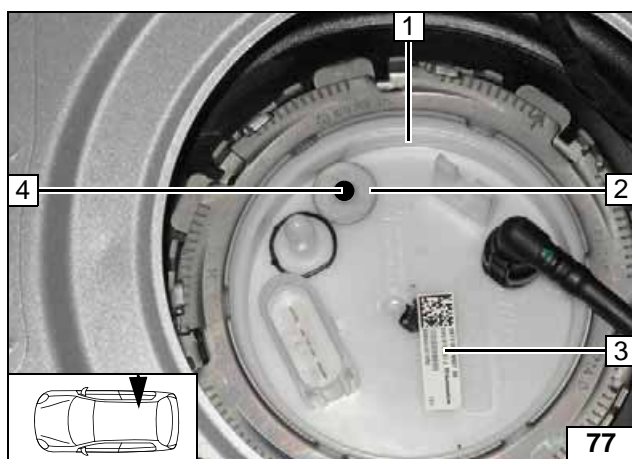

Installing FuelFix

Petrol

Work steps F1, F2 and F3.

Move sticker to position 3.

- 1 Fuel tank sending unit, right side
- 2 Position washer with outer dia. $d_a = 21.6\text{mm}$ as template at the edge and the marked nipple.
- 4 Hole pattern, hole made with provided drill



Copying
hole pattern

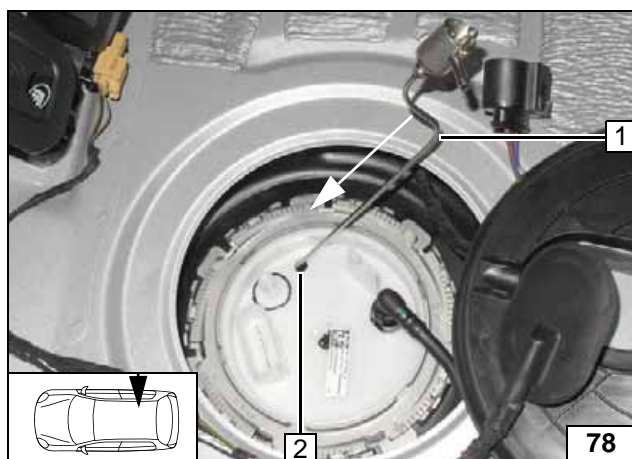

Work steps F4 and F5.

Bend FuelFix 1 according to template and cut to length.
Insert into hole 2.



Inserting
FuelFix



Inserting
FuelFix



Inserting FuelFix

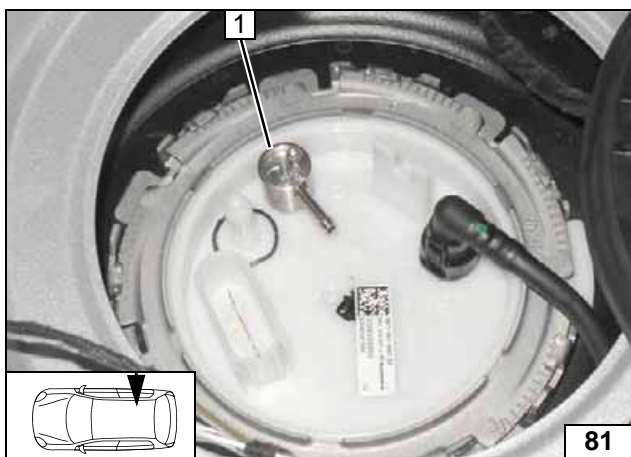

Work steps F5.3 and 5.4.

Position FuelFix 1 as shown .

Aligning FuelFix

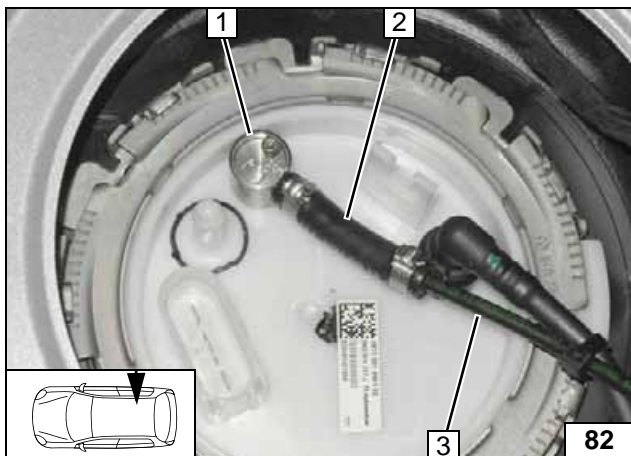

Work step F6.

- 1 FuelFix
- 2 Hose section, 10mm dia. clamp [2x]
- 3 Fuel line

Connecting fuel line

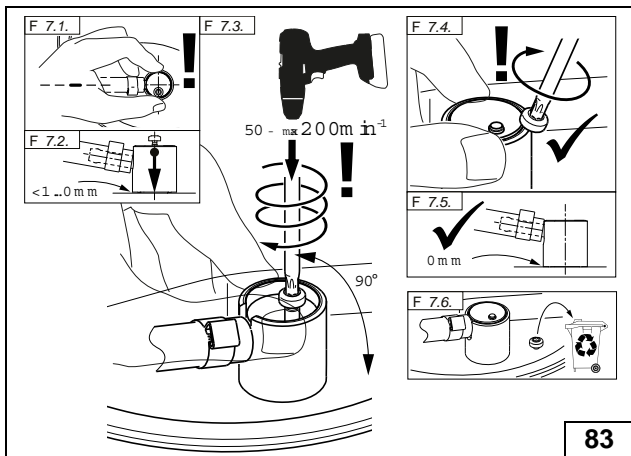

Work step F7.

Installing FuelFix

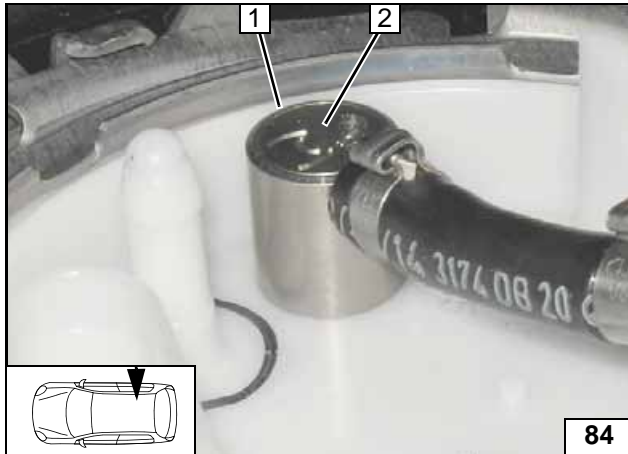

Work step F8.

Ensure firm seating of FuelFix and positioning of clamping piece 2 with respect to upper edge 1 of the housing.



Checking final position

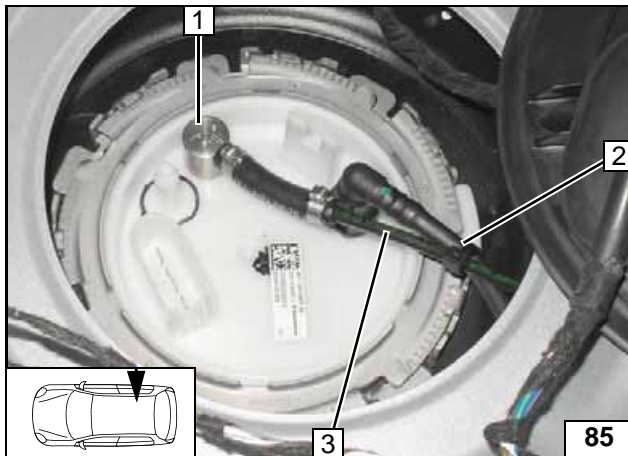

Work step F8.

- 1 FuelFix installed
- 2 Cable tie as tension relief
- 3 Fuel line of FuelFix



Securing fuel line

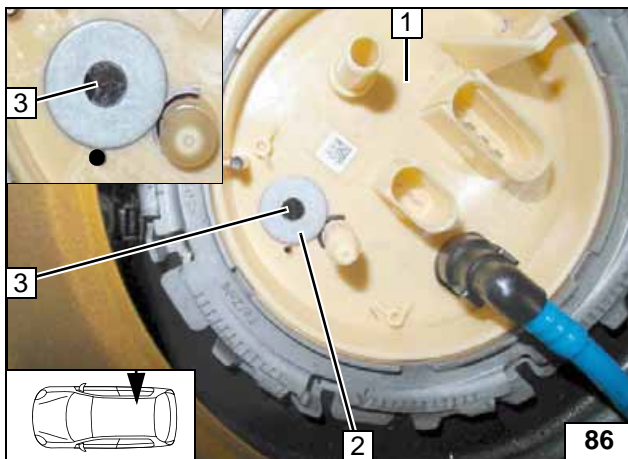

Diesel

Version 1

Work steps F1, F2 and F3.

- 1 Fuel tank sending unit
- 2 Position washer with outer dia. $d_a = 21.6\text{mm}$ as template at the connection piece and the marked nipple.
- 3 Hole pattern, hole made with provided drill



Copying hole pattern, drilling hole

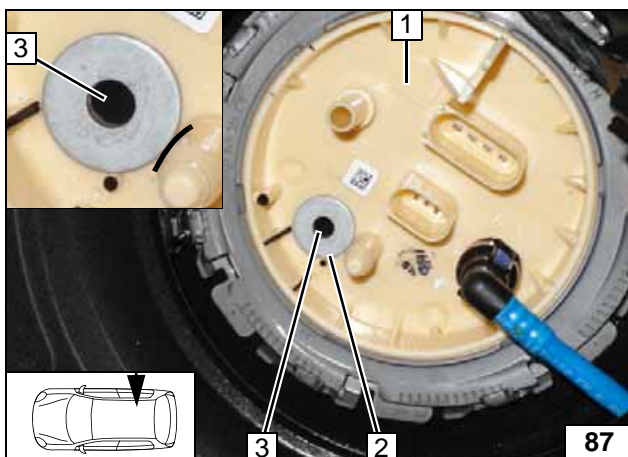

Version 2

Work steps F1, F2 and F3.

- 1 Fuel tank sending unit
- 2 Position washer with outer dia. $d_a = 21.6\text{mm}$ as template at the connection piece, the rib and the marked nipple.
- 3 Hole pattern, hole made with provided drill



Copying hole pattern, drilling hole

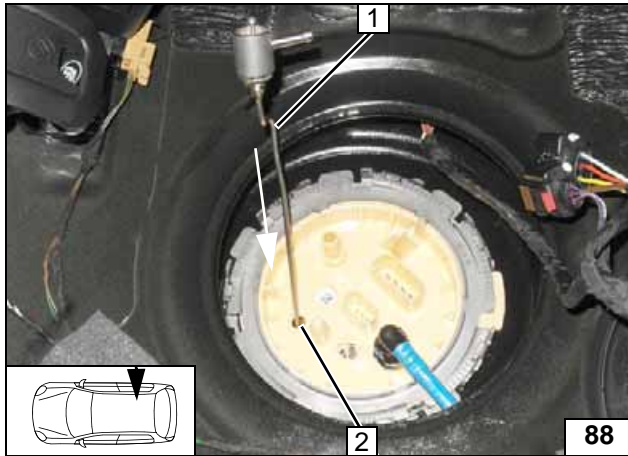
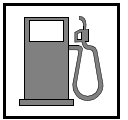

All versions

Work steps F4 and F5.

Bend FuelFix 1 according to template and cut to length.
Insert into hole 2.



Inserting FuelFix

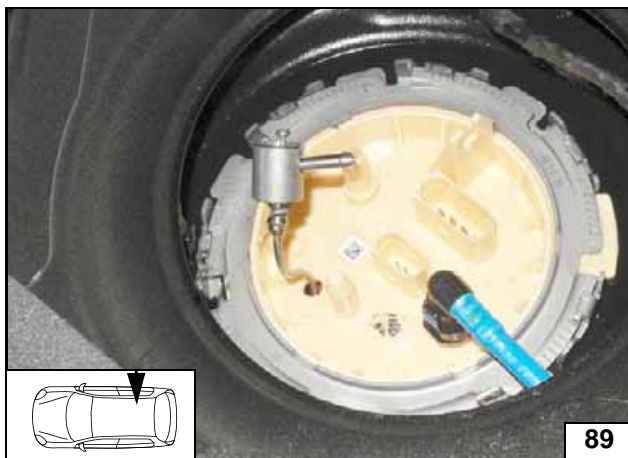

Inserting FuelFix



Inserting FuelFix

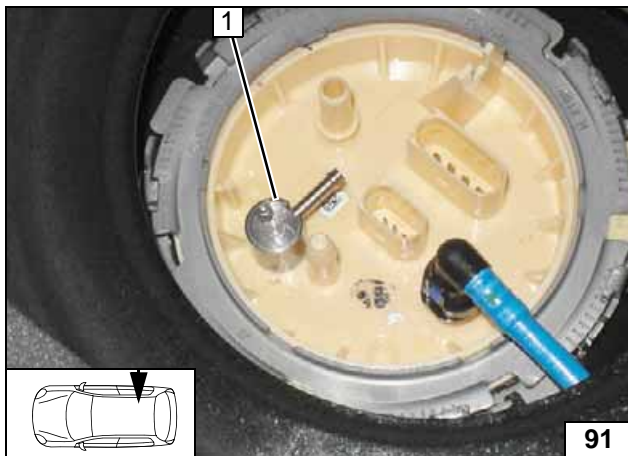

Work steps F5.3 and F5.4.

Position FuelFix 1 as shown .



Aligning FuelFix

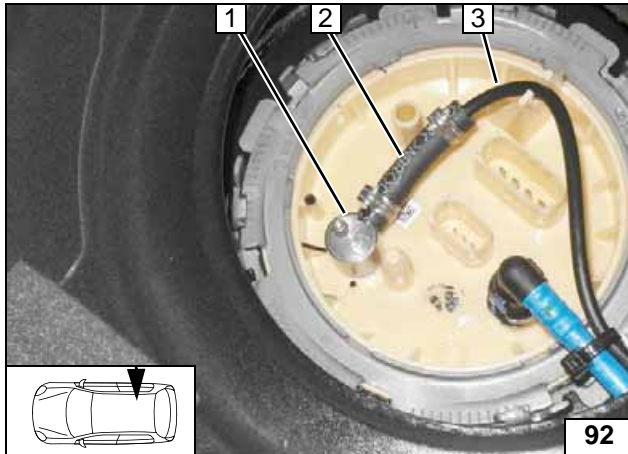
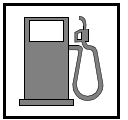

Work step F6.

- 1 FuelFix
- 2 Hose section, 10mm dia. clamp [2x]
- 3 Fuel line



Connect-
ing fuel line

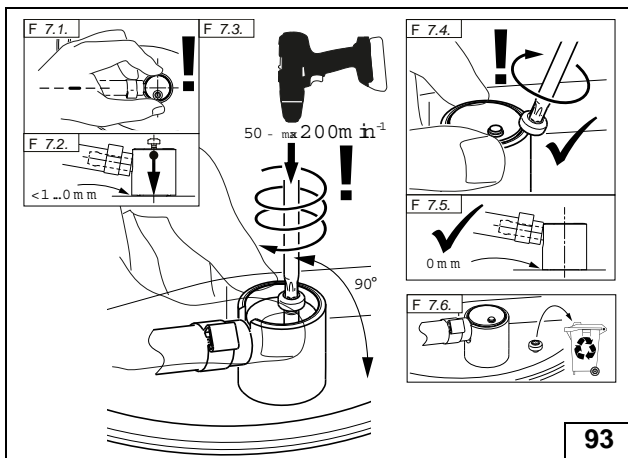

Work step F7.



Installing
FuelFix

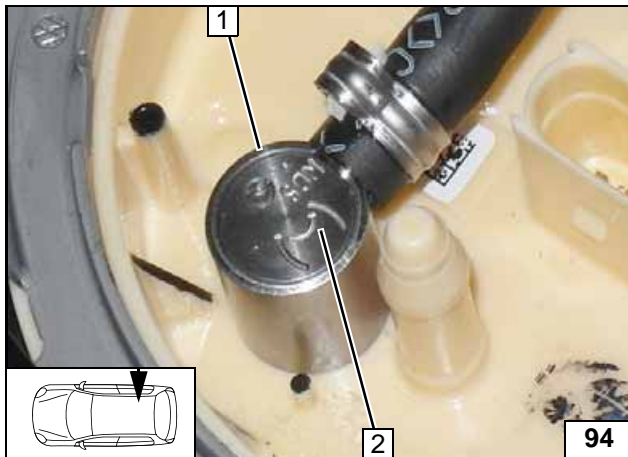

Work step F8.

Ensure firm seating of FuelFix and positioning of clamping piece 2 with respect to upper edge 1 of the housing.



Checking
final posi-
tion

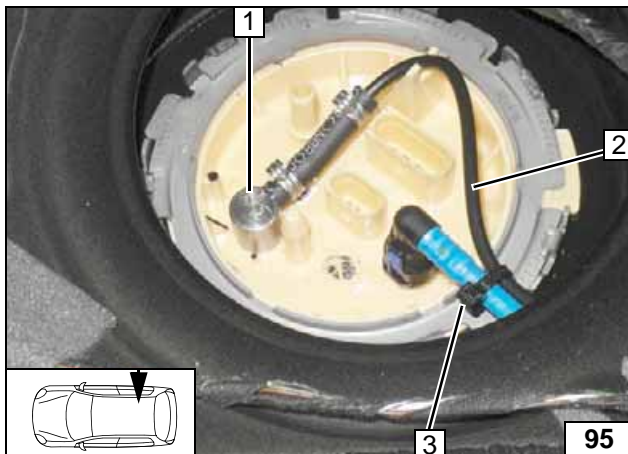

Work step F8.

- 1 FuelFix installed
- 2 Fuel line of FuelFix
- 3 Cable tie as tension relief



Securing
fuel line

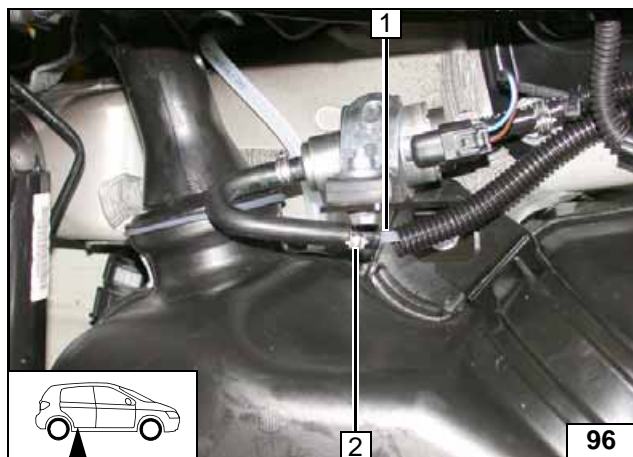

All vehicles

Slide corrugated tube onto fuel line **1**. Check the position of the components; adjust if necessary. Check that they have freedom of movement.

2 10 mm dia. clamp



**Connect-
ing meter-
ing pump**

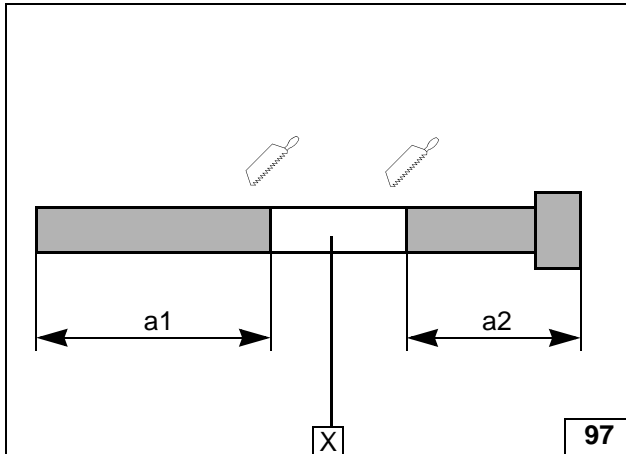
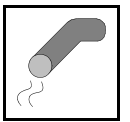

Exhaust Gas

a1 = 240mm - exhaust pipe
a2 = 140mm - exhaust end section

X =

Preparing exhaust pipe

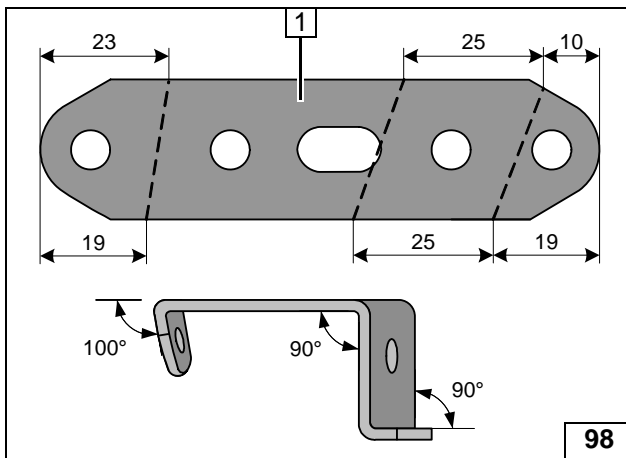

1 Perforated bracket



Preparing perforated bracket

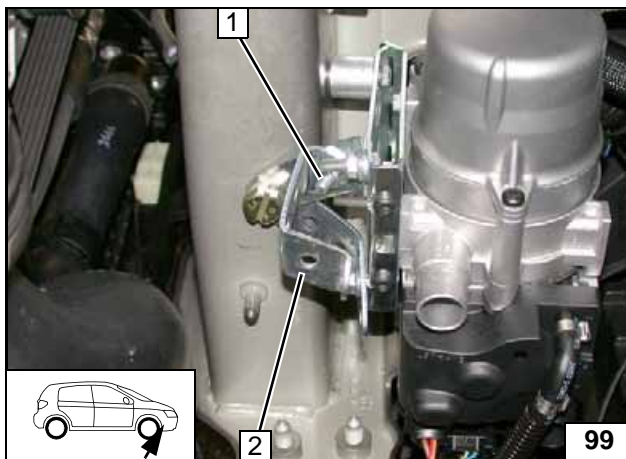

- 1 M6x20 bolt, large diameter washer, flanged nut
- 2 Perforated bracket

Installing perforated bracket

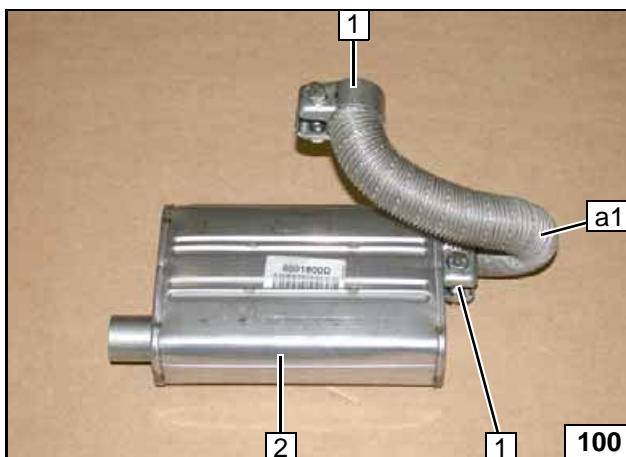

- 1 Hose clamp [2x]
- 2 Exhaust silencer

Pre-mounting silencer

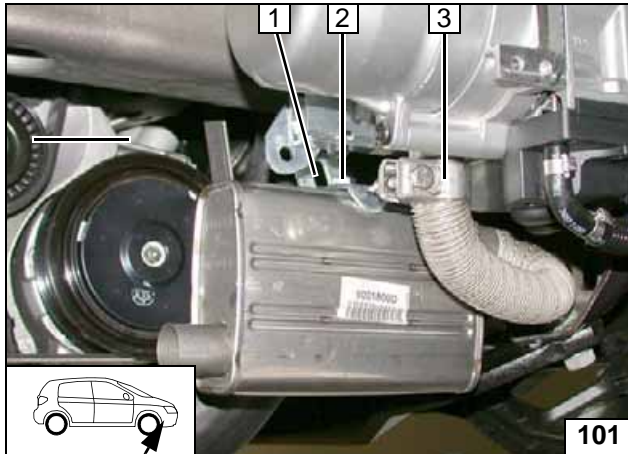
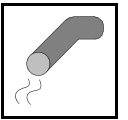

- 1 Perforated bracket
- 2 M6x16 bolt, spring lockwasher
- 3 Tighten hose clamp

Installing silencer

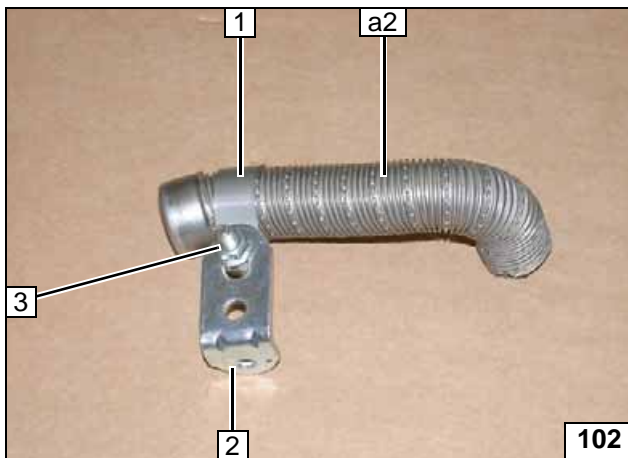

- 1 P-clamp
- 2 Angle bracket
- 3 M6x20 bolt, flanged nut

Premounting exhaust end section

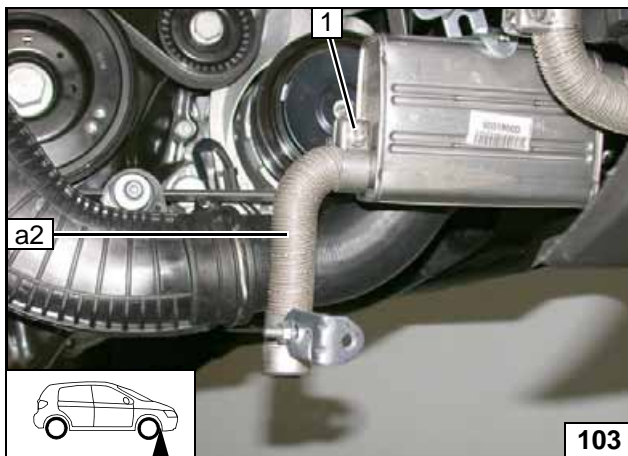

- 1 Hose clamp
- 2 Exhaust end section

Installing exhaust end section

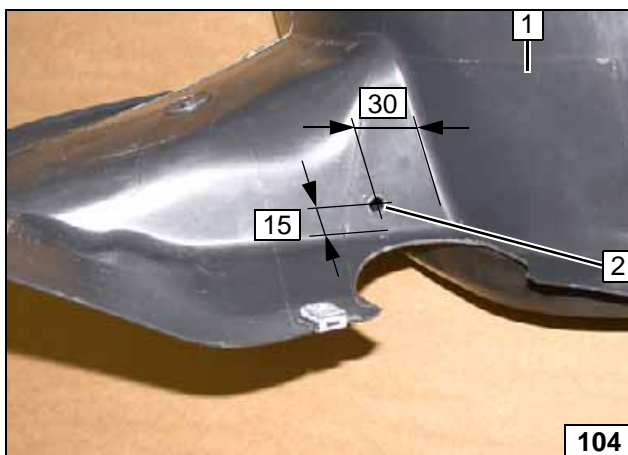

- 1 Wheel-well inner panel
- 2 7 mm dia. hole

Cutting out wheel-well inner panel

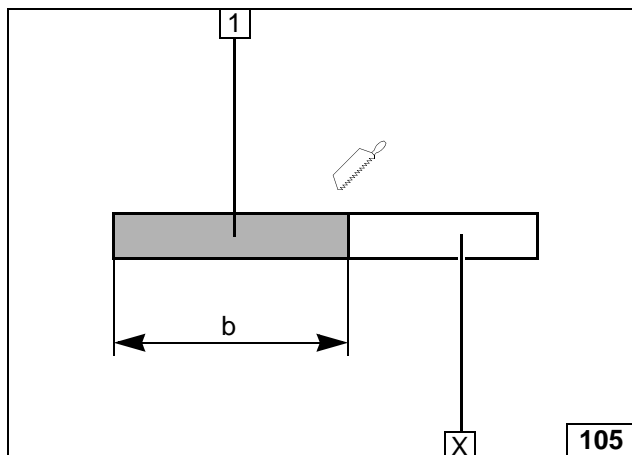
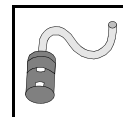

Combustion Air

- 1 Combustion air pipe
b = 360

X =

Cutting combustion air pipe to length

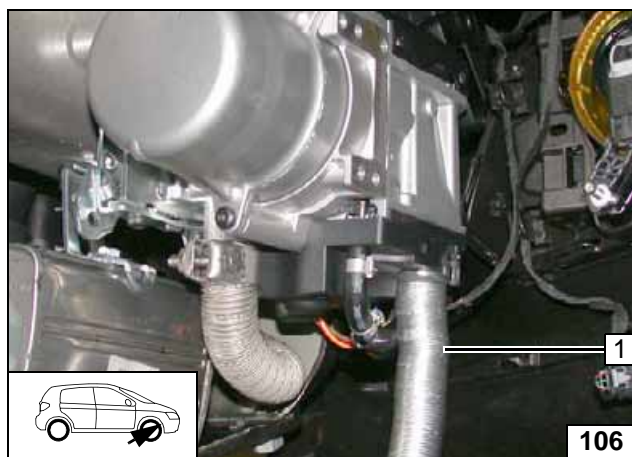

- 1 Combustion air pipe



Installing combustion air pipe

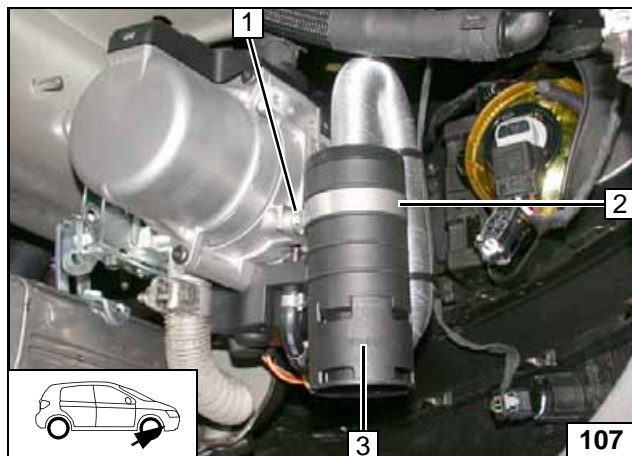

- 1 5x13 self-tapping bolt
- 2 51 mm dia. clamp
- 3 Silencer



Installing silencer



Final Work



Install removed parts in reverse order. Check all hoses, clamps and all electrical connections for firm seating. Insulate and tie back all loose lines. Only use manufacturer-approved coolant. Spray the heater components with anti-corrosion wax (Tectyl 100K, Order No. 111329).

- Connect the battery.
- Fill and bleed the coolant circuit according to the vehicle manufacturer's specifications.
- Set digital timer, teach Telestart transmitter.
- Make settings on A/C control panel according to the 'Operating Instructions for End Customer'.
- Place the 'Switch off parking heater before refuelling' caution label near the filler neck.
- For initial startup and function check, please see installation instructions.

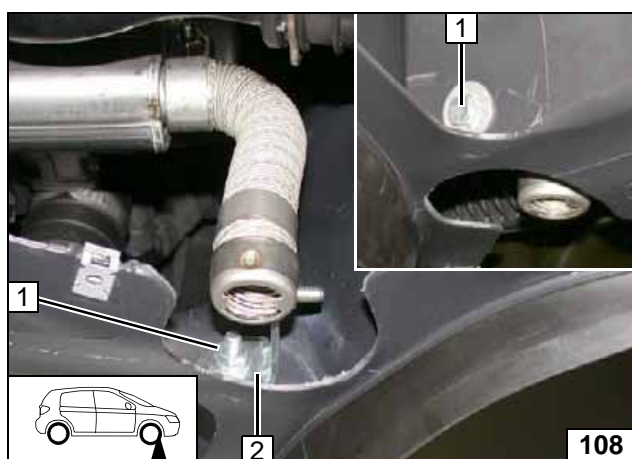

Mount wheel-well inner panel.

- 1 M6x20 bolt, large diameter washer, flanged nut
- 2 Angle bracket



Securing exhaust end section

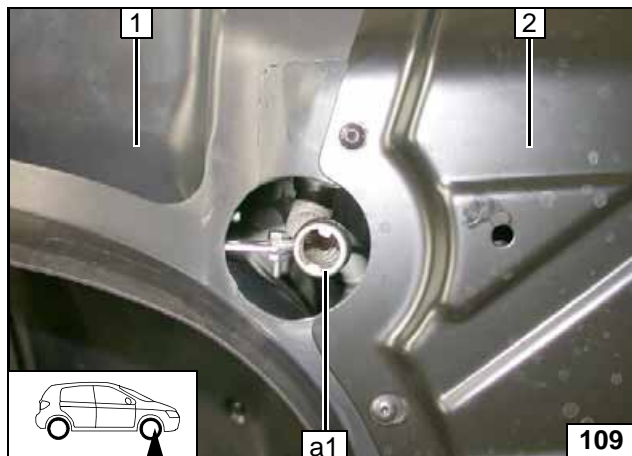

Ensure sufficient distance from neighbouring components. Align exhaust end section **a1** with the centre of the under-ride protection **1** / wheel-well inner panel **2** hole.



Aligning exhaust end section

Webasto Thermo & Comfort SE
Postfach 1410
82199 Gilching
Germany
Internet: www.webasto.com
Technical Extranet:
<http://dealers.webasto.com>



FuelFix Template

Top view

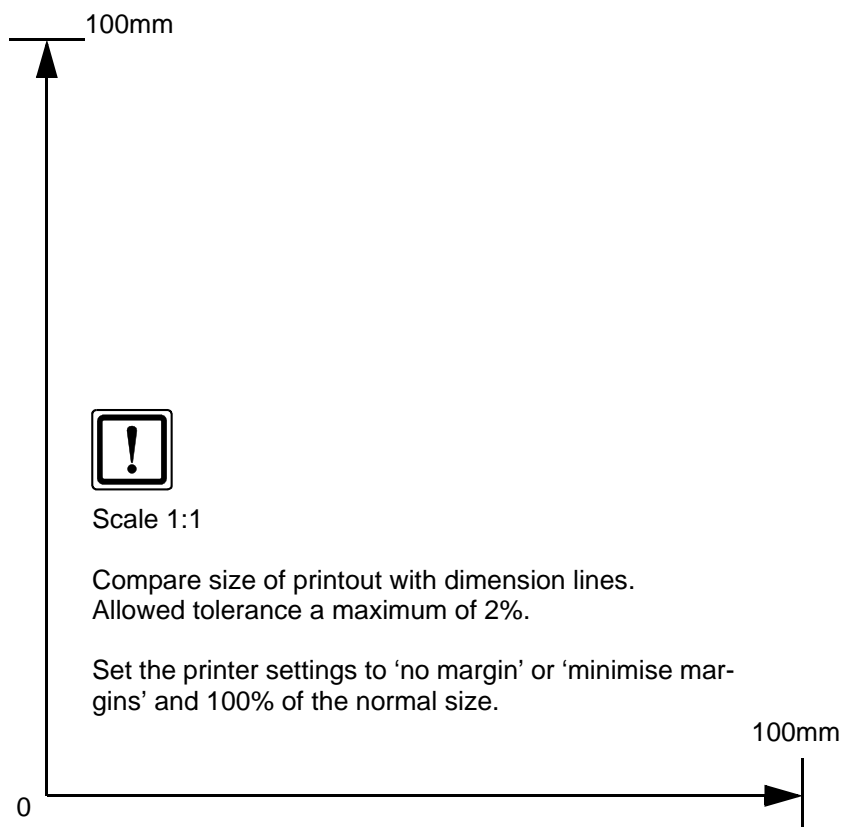
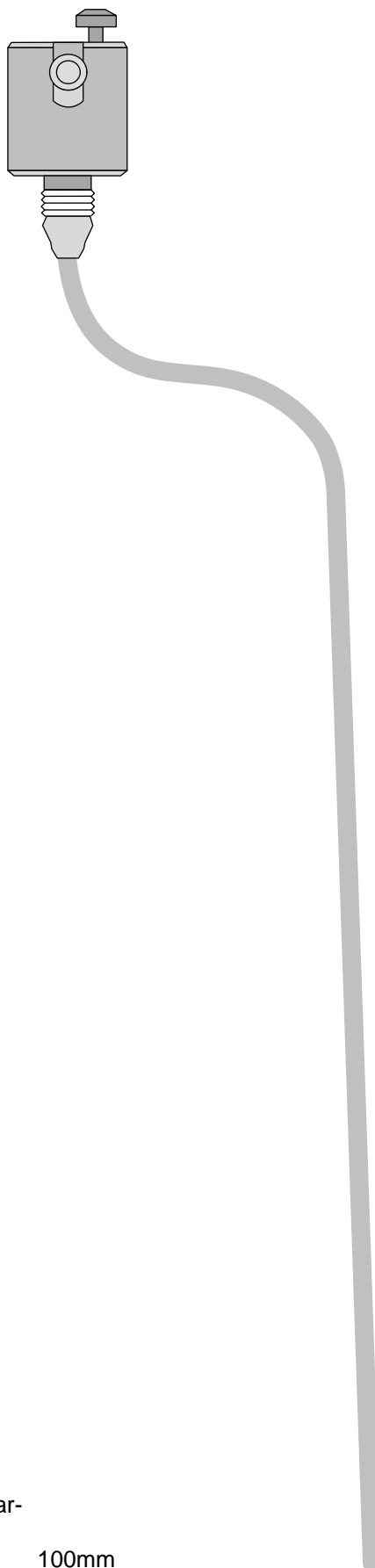
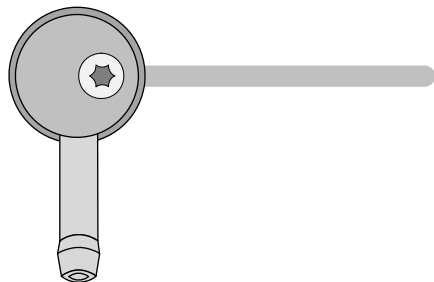

Operating Instructions for End Customer

Please remove page and add to the vehicle operating instructions.

Note:

We recommend matching the heating time to the driving time.
 Heating time = driving time

Example:

For a driving time of approx. 20 min. (in one direction), we recommend not exceeding a switch-on time of 20 min.

Passenger compartment monitoring, if installed, must be deactivated in addition to vehicle settings for the heating operation .

For instructions on deactivation, please refer to the operating instructions of the vehicle.

Before parking the vehicle, make the following settings:

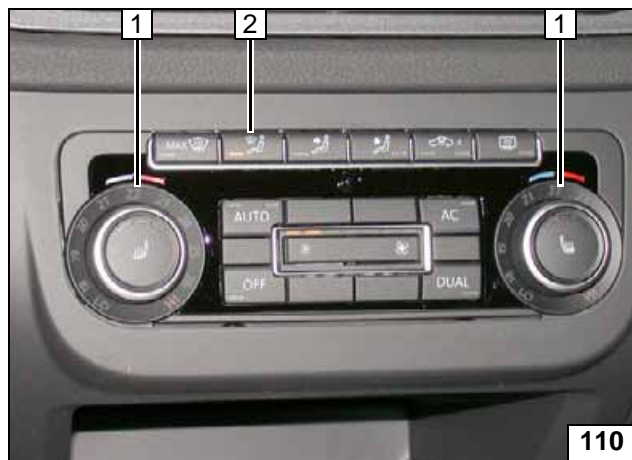

- 1 Set temperature to 'HI'
- 2 Air outlet to windscreen



A/C control panel

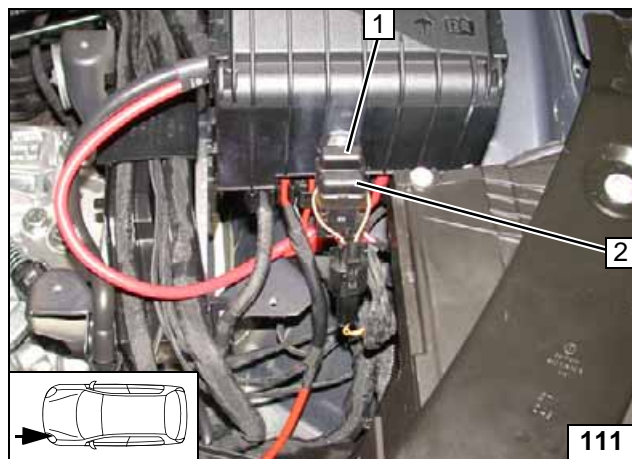

- 1 30A main fuse F2 of passenger compartment
- 2 20A heater fuse F1

Engine compartment fuses

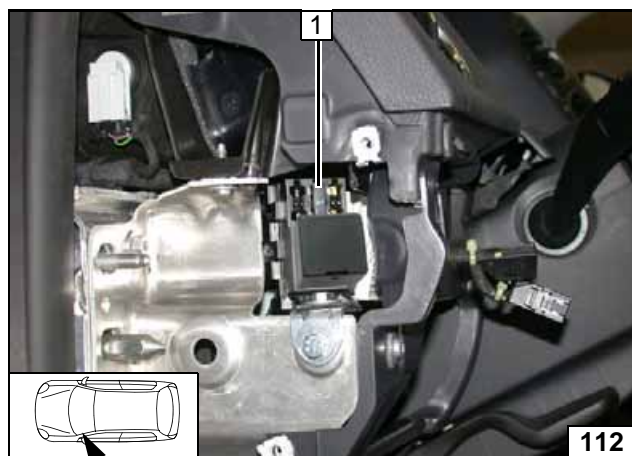

- 1 1A fuse F3 of heater control

Passenger compartment fuse

