

# Water Heater

## Thermo Top Evo Parking Heater



## Installation Documentation Skoda Citigo / VW up / Seat Mii

### Validity

Manufacturer	Model	Type	EG-BE No./ ABE
Skoda	Citigo	AA	e13 * 2001 / 46 * 1169 * ...
VW	up	AA	e13 * 2007 / 46 * 1167 * ...
Seat	Mii	AA	e13 * 2007 / 46 * 1168 * ...

Motorisation	Fuel	Transmission type	Output in kW	Displacement in cm <sup>3</sup>	Engine code
1.0 MPI	Petrol	5-gear SG	44	999	CHYA
1.0 MPI	Petrol	5-gear SG	55	999	CHYB

SG = manual transmission

**From Model Year 2012**

**Left-hand drive vehicle**

**Verified equipment variants:** Manual air-conditioning  
Front fog light

**Not verified:** Passenger compartment monitoring  
Automatic transmission  
Automatic air-conditioning  
Headlight washer system  
blue motion

**Total installation time:** approx. 7 hours

## Table of Contents

Validity	1	Preparing Installation Location	11
Necessary Components	2	Preparing Heater	12
Installation Overview	2	Installing Heater	13
Information on Total Installation Time	2	Exhaust Gas	15
Information on Operating and Installation Instructions	3	Fuel	18
Information on Validity	4	Coolant Circuit	21
Technical Information	4	Final Work	25
Explanatory Notes on Document	4	Template for Fuel Standpipe	26
Preliminary Work	5	Drilling Template of Bracket	27
Heater Installation Location	5	Operating Instructions for End Customer	28
Preparing Electrical System	6		
Electrical System	7		
Fan Controller	8		
Digital Timer	10		
Remote Option (Telestart)	10		

## Necessary Components

- Basic delivery scope *Thermo Top Evo* in accordance with price list
- Installation kit for Skoda Citigo / VW up / Seat Mii 2012 Petrol: **1318215A**
- Heater control in accordance with price list and upon consultation with end customer
- In case of Telestart, indicator lamp in accordance with price list and in consultation with end customer

## Installation Overview

### Legend:

1. Heater
2. Engine compartment fuse holder
3. Passenger compartment fuse holder
4. Circulating pump
5. Digital timer
6. Metering pump

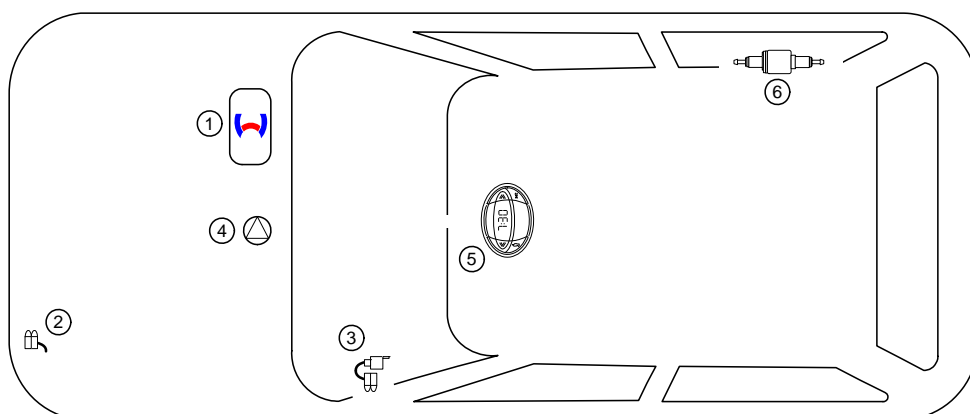

## Information on Total Installation Time

The total installation time includes the time needed for mounting and demounting of the vehicle-specific components, the heater specific installation time and all other times required for the system integration and initial start-up of the heater.

The total installation time may vary for vehicle equipment other than provided.

## Information on Operating and Installation Instructions

### 1 Important Information (not complete)

#### 1.1 Installation and Repair



The improper installation or repair of Webasto heating and cooling systems can cause fire or the leakage of deadly carbon monoxide, leading to serious injury or death.



To install and repair Webasto heating and cooling systems you need to have completed a special company training course and have the appropriate technical documentation, special tools and special equipment.



Installation and repair may ONLY be carried out by persons trained and certified in a Webasto training course. NEVER try to install or repair Webasto heating or cooling systems if you have not completed a Webasto training course, you do not have the necessary technical skills and you do not have the technical documentation, tools and equipment available to ensure that you can complete the installation and repair work properly.

Only use genuine Webasto parts. See the Webasto air and water heaters accessories catalogue for this purpose.

#### 1.2 Operation

To ensure safe operation, we recommend having the heater checked every two years by an authorised Webasto dealer, especially when used over a long period and/or under extreme environmental conditions.

Do not operate the heater in closed rooms due to the danger of poisoning and suffocation.

Always switch off the heater before refuelling.

The heater may only be used with the prescribed fuel Diesel (DIN EN 590) or petrol (DIN EN 227).

The heater may not be cleaned with a high-pressure cleaner.

#### 1.3 Please note

ALWAYS follow all Webasto installation and operating instructions and observe all warnings.

To become familiar with and understand all functions and properties of the heater, the operating instructions must be read carefully and observed at all times.

For proper, safe installation and repair work, the installation instructions with all warnings and safety information must be carefully read and observed at all times. Please always contact a workshop authorised by Webasto for all installation and repair work.

### IMPORTANT

**Webasto shall assume no liability for defects, damage and injuries resulting from a failure to observe the installation, repair and operating instructions of the information contained in them.**

**This liability exclusion particularly applies to improper installations and repairs, installations and repairs by untrained persons or in the case of a failure to use genuine spare parts.**

**The liability due to culpable disregard to life, limb or health and due to damage or injuries caused by a wilful or reckless breach of duty remain unaffected, as does the obligatory product liability.**

**Installation should be carried out according to the general, standard rules of technology. Unless specified otherwise, fasten hoses, lines and wiring harnesses to original vehicle lines and wiring harnesses using cable ties. Insulate loose wire ends and tie back.**

**Sharp edges should be fitted with rub protection (split-open fuel hose)! Spray unfinished body areas, e.g. drilled holes, with anti-corrosion wax (Tectyl 100K, Order No. 111329).**

**Observe the instructions and guidelines of the respective vehicle manufacturer for demounting and mounting vehicle specific components!**

**The initial startup is to be executed with the Webasto Thermo Test Diagnosis.**

**When installing an IPCU, the corresponding settings must be checked or adjusted before the installation.**

### 2 Statutory regulations governing installation

Guidelines	Thermo Top Evo
Heating Directive ECE R122	E1 00 0258
EMC Directive ECE R10	E1 03 5627

#### NOTE

The regulations of these guidelines are binding in the scope of the Directive 70/156/EEC and/or 2007/46/EC (for new vehicle models from 29/04/2009) and should also be observed in countries in which there are no special regulations.

### IMPORTANT

Failure to follow the installation instructions will result in the invalidation of the type approval for the heater and therefore invalidation of the general **homologation of the vehicle**.

#### NOTE

For vehicles with an EU permit, no entry in accordance with § 19 Sub-Section 4 of Annex VIII b to the Road Traffic Act is required.

#### 2.1 Excerpt from the directive 2001/56/EC Appendix VII for the installation of the heater

Beginning of excerpt.

### ANNEX VII

#### REQUIREMENTS FOR COMBUSTION HEATERS AND THEIR INSTALLATION

##### 1. GENERAL REQUIREMENTS

1.1.1. A clearly visible tell-tale in the operator's field of view shall inform when the combustion heater is switched on or off.

##### 2. VEHICLE INSTALLATION REQUIREMENTS

###### 2.1. Scope

2.1.1. Subject to paragraph 2.1.2. combustion heaters shall be installed according to the requirements of this Annex.

2.1.2. Vehicles of category O having liquid fuel heaters are deemed to comply with the requirements of this Annex.

###### 2.2. Positioning of heater

2.2.1. Body sections and any other components in the vicinity of the heater must be protected from excessive heat and the possibility of fuel or oil contamination.

2.2.2. The combustion heater shall not constitute a risk of fire, even in the case of overheating. This requirement shall be deemed to be fulfilled if the installation ensures an adequate distance to all parts and suitable ventilation, by the use of fire resistant materials or by the use of heat shields.

2.2.3. In the case of M2 and M3 vehicles, the heater must not be positioned in the passenger compartment. However, an installation in an effectively sealed envelope which also complies with the conditions in paragraph 2.2.2 may be used.

2.2.4. The label referred to in paragraph 1.4 or a duplicate, must be positioned so that it can be easily read when the heater is installed in the vehicle.

2.2.5. Every reasonable precaution should be taken in positioning the heater to minimise the risk of injury and damage to personal property.

###### 2.3. Fuel supply

2.3.1. The fuel filler must not be situated in the passenger compartment and must be provided with an effective cap to prevent fuel spillage.

2.3.2. In the case of liquid fuel heaters, where a supply separate to that of the vehicle is provided, the type of fuel and its filler point must be clearly labelled.

2.3.3. A notice, indicating that the heater must be shut down before refuelling, must be affixed to the fuelling point. In addition a suitable instruction must be included in the manufacturer's operating manual.

###### 2.4. Exhaust system

2.4.1. The exhaust outlet must be located so as to prevent emissions from entering the vehicle through ventilators, heated air inlets or opening windows.

###### 2.5. Combustion air inlet

2.5.1. The air for the combustion chamber of the heater must not be drawn from the passenger compartment of the vehicle.

2.5.2. The air inlet must be so positioned or guarded that blocking by rubbish or luggage is unlikely.

###### 2.6. Heating air inlet

2.6.1. The heating air supply may be fresh or recirculated air and must be drawn from a clean area not likely to be contaminated by exhaust fumes emitted either by the propulsion engine, the combustion heater or any other vehicle source.

2.6.2. The inlet duct must be protected by mesh or other suitable means.

###### 2.7. Heating air outlet

2.7.1. Any ducting used to route the hot air through the vehicle must be so positioned or protected that no injury or damage could be caused if it were to be touched.

2.7.2. The air outlet must be so positioned or guarded that blocking by rubbish or luggage is unlikely.

End of excerpt.

In multilingual versions the German language is binding.

## Information on Validity

This installation documentation applies to Skoda Citigo / VW up / Seat Mii Petrol vehicles - for validity, see page 1 - from model year 2012 and later, assuming technical modifications to the vehicle do not affect installation, any liability claims excluded. Depending on the vehicle version and equipment, modifications may be necessary during installation with respect to this installation documentation.

Vehicle and engine types, equipment variants and other specifications not listed in this installation documentation have not been tested. However, installation according to this installation documentation may be possible.

## Technical Information

### Special tools

- Hose clamp pliers for self-clamping hose clamps
- Hose clamp pliers for Clic hose clamps of type W
- Automatic wire stripper 0.2 - 6mm<sup>2</sup>
- Crimping pliers for cable lug / tab connector 0.5 - 6mm<sup>2</sup>
- Torque wrench for 2.0 - 10 Nm
- Hose clamping pliers
- Webasto Thermo Test Diagnosis with current software

### Dimensions

- All dimensions are in mm

### Tightening torque values

- Tightening torque values of 5x13 heater bolts = 8Nm.
- Tightening torque values of 5x15 retaining plate of water connection piece bolts = 7Nm.
- Tighten other bolt connections in accordance with manufacturer's instructions or in accordance with state-of-the-art-technology.

## Explanatory Notes on Document

You will find an identification mark on the outside top right corner of the page in question to provide you with a quick overview of the individual working steps.

Special features are highlighted using the following symbols:

### Mechanical system



### Electrical system



### Coolant circuit

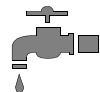

### Combustion air

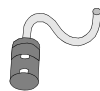

### Fuel



### Exhaust gas



### Software



### Specific risk of injury or fatal accidents



### Specific risk of damage to components



### Specific risk of fire and explosion



### Reference to general installation instructions of the Webasto components or to the manufacturer's vehicle-specific documents.



### Reference to a special technical feature



### The arrow in the vehicle icon indicates the position on the vehicle and the viewing angle

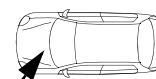

## Preliminary Work

### Vehicle

- Open the fuel tank cap.
- Ventilate the fuel tank.
- Close the fuel tank cap again.
- Depressurise the cooling system.
- Disconnect and completely remove the battery together with the carrier.
- Remove the air filter together with the intake hose.
- Remove the coolant reservoir cap.
- Remove the windscreen wiper.
- Remove the right-hand wheel well trim.
- Remove the rear bench seat.
- Open the right-hand tank-fitting service lid.
- Remove the fuel-tank sending unit in accordance with the manufacturer's instructions.
- Remove the instrument panel trim beneath the steering wheel.

### Heater

- Remove years that do not apply from the type and duplicate label.
- Attach the duplicate label (type label) in the appropriate place in the engine compartment.

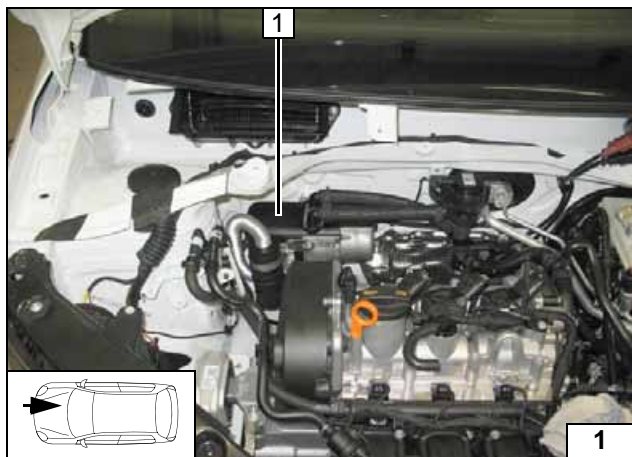

### Heater Installation Location

1 Heater

Installation  
location

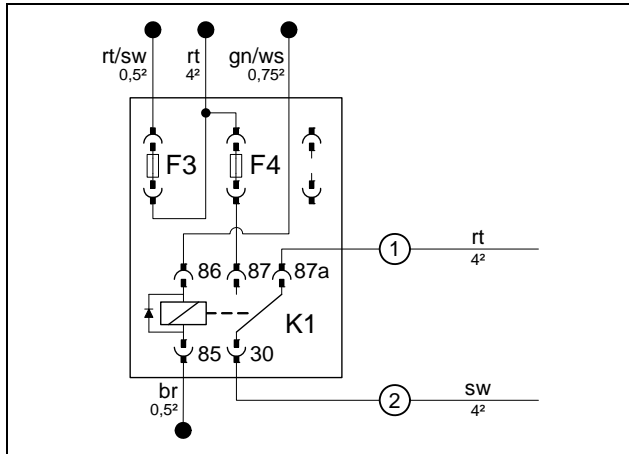

## Preparing Electrical System

Produce connections as shown in wiring diagram. 1A fuse F3, 25A fuse F4 and K1 relay will not be inserted until after the installation of the fuse holder.



**Preparing fuse holder of passenger compartment**

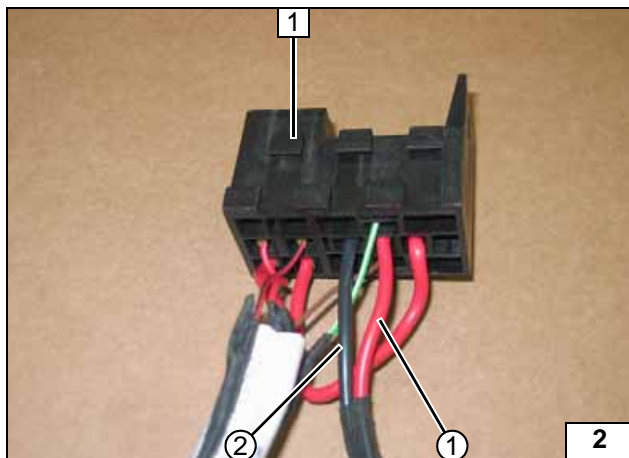

- 1 Fuse holder of passenger compartment
- ① Red (rt) wire from K1/87a
- ② Black (sw) wire from K1/30

**Connecting wires**

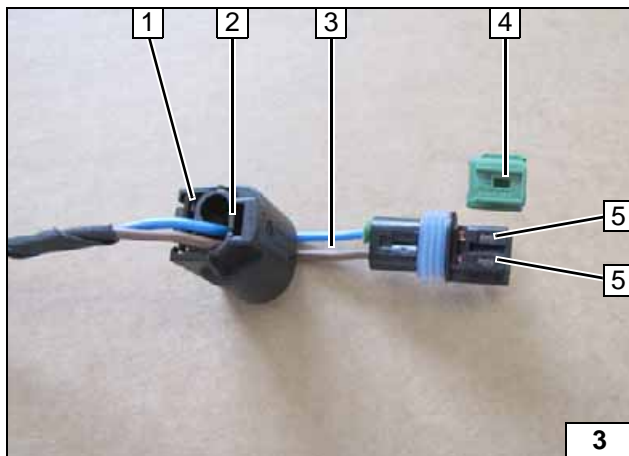

Reassemble connector of metering pump after routing. Pin assignment is not relevant.



- 1 Connector housing
- 2 Lock
- 3 Blue / brown (bl/br) wires
- 4 Coding
- 5 Timer lock

**Removing connector**



## Electrical System

### Earth wire

Positive wire will be installed to the battery positive distributor later.

- 1 Earth wire on original vehicle earth support point

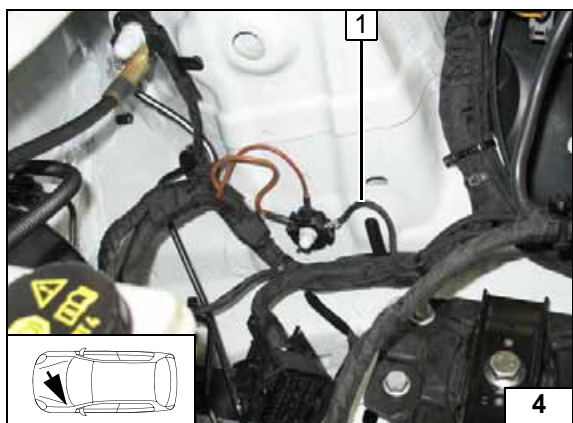

### Wiring harness routing

Route wiring harnesses of heater and circulating pump **2** to the installation location of the heater along original vehicle brake lines.

- 1 Wiring harnesses of circulating pump

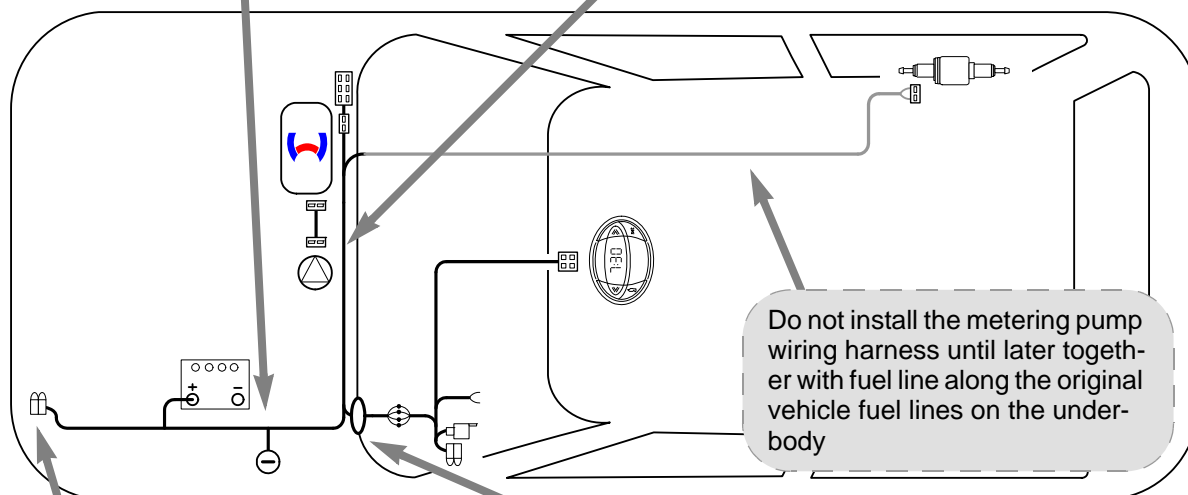
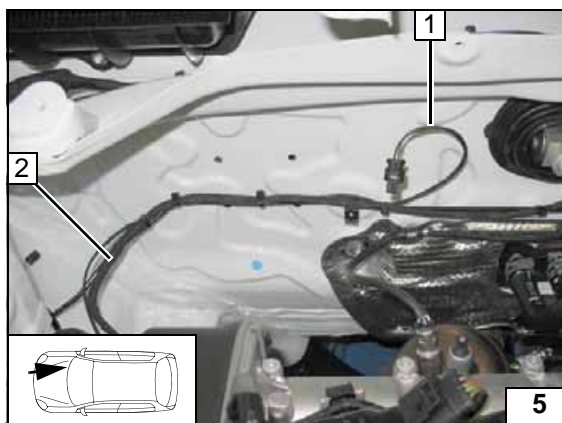

Wiring harness routing diagram

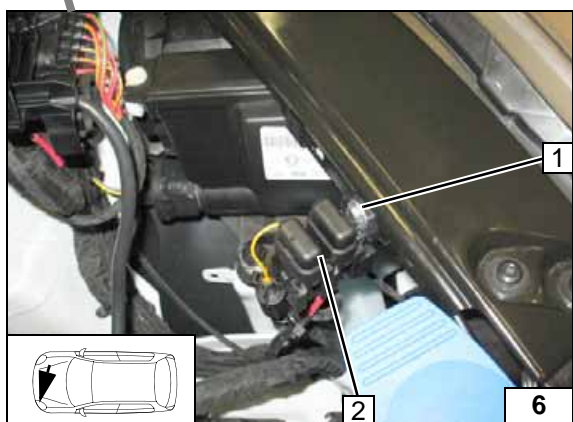

### Fuse holder of engine compartment

- 1 M5x16 bolt, washer [2x], retaining plate of fuse holder, nut, existing hole
- 2 Fuses F1-2

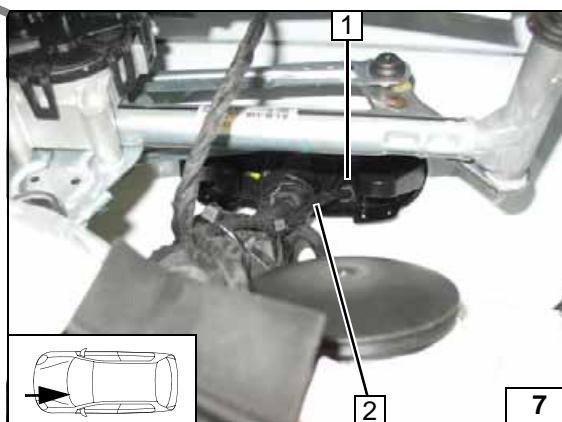

### Wiring harness pass through

- 1 Protective rubber plug
- 2 Wiring harnesses of heater, heater control

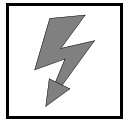

Fan Controller

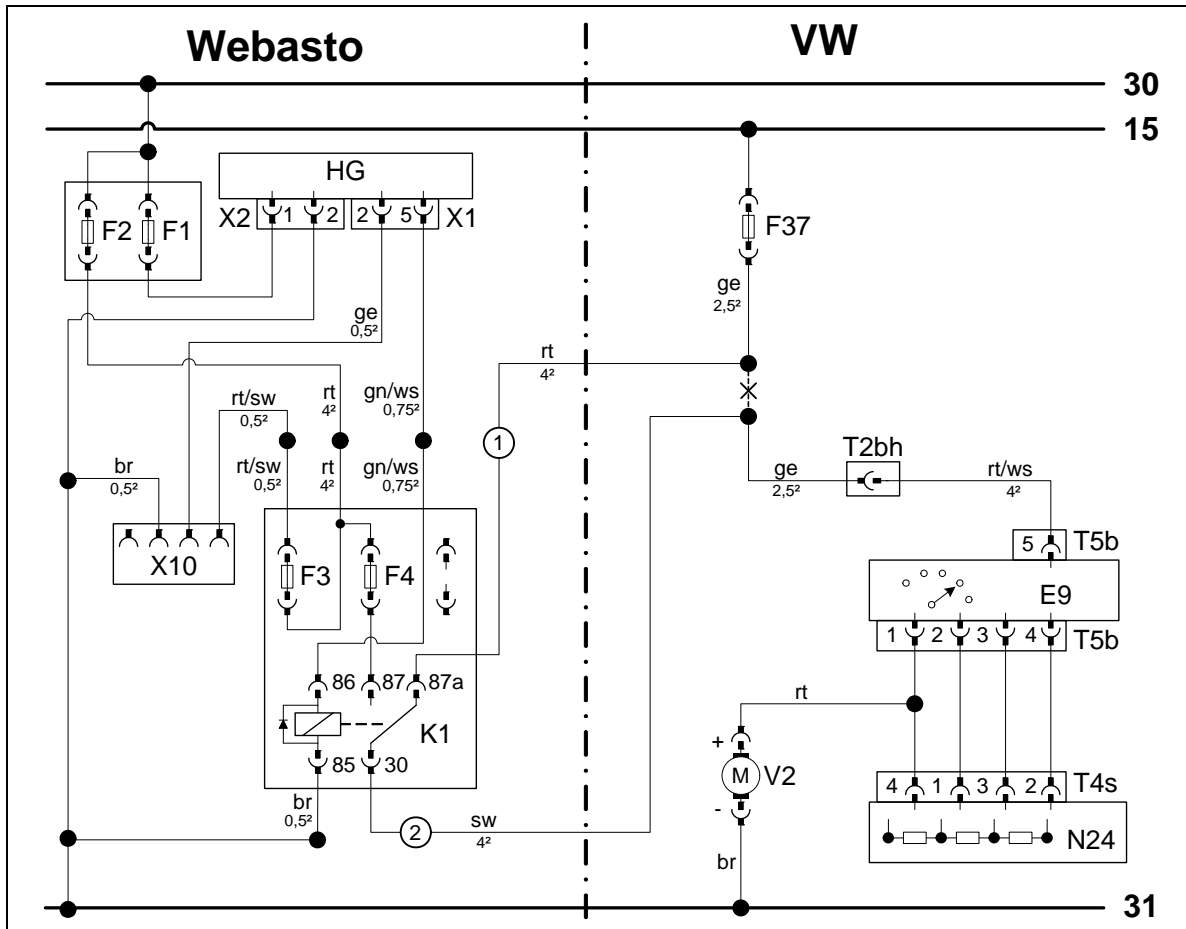

Wiring diagram

Webasto components		Vehicle components		Colours and symbols	
HG	Heater TT-Evo	E9	Fan switch	rt	red
X1	6-pin heater connector	T5b	5-pin connector E9	sw	black
X2	2-pin heater connector	N24	Resistor group	ge	yellow
X10	4-pin connector Heater control	T4s	4-pin connector N24	gn	green
K1	Fan relay	V2	Fan motor	or	orange
F1	Fuse, 20A	T2bh	2-pin connector	ws	white
F2	Fuse, 30A	F37	Fuse, 30A	br	brown
F3	Fuse, 1A			X	Cutting point
F4	Fuse, 25 A			Wiring colours may vary.	

Legend

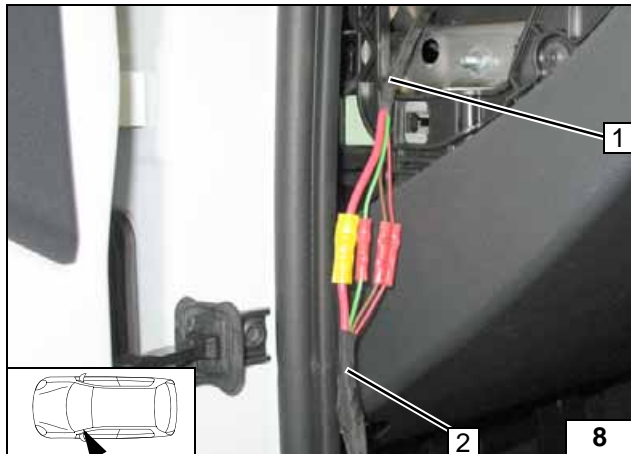

Connect same colour wires of passenger compartment fuse holder wiring harness 2 and wiring harness of heater 1 according to wiring diagram.



Connecting the wiring harnesses



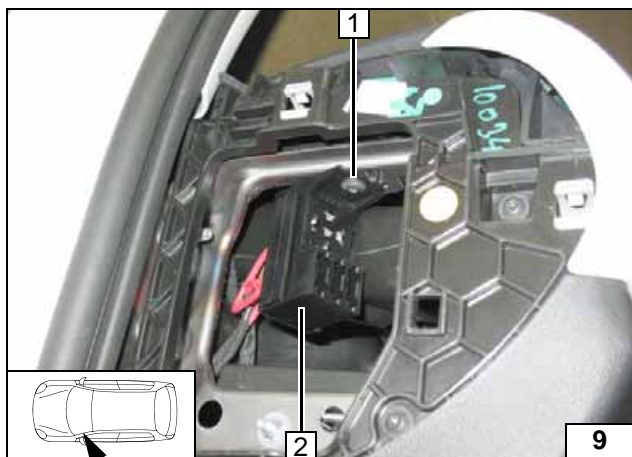

- 1 Original vehicle bolt
- 2 Fuse holder of passenger compartment

Installing fuse holder of passenger compartment

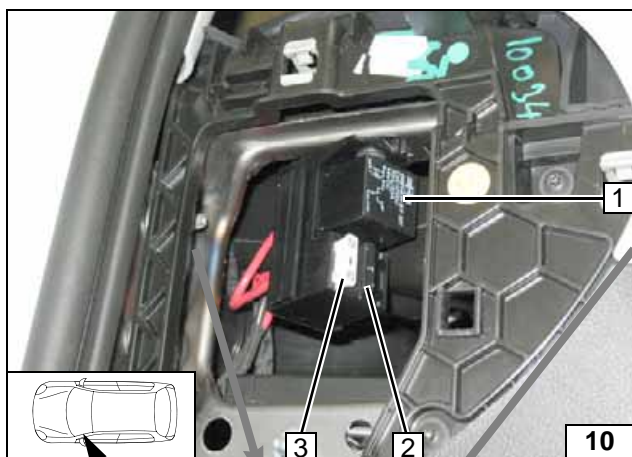

- 1 K1 relay
- 2 1A fuse F3
- 3 25A fuse F4

Completing fuse holder of passenger compartment

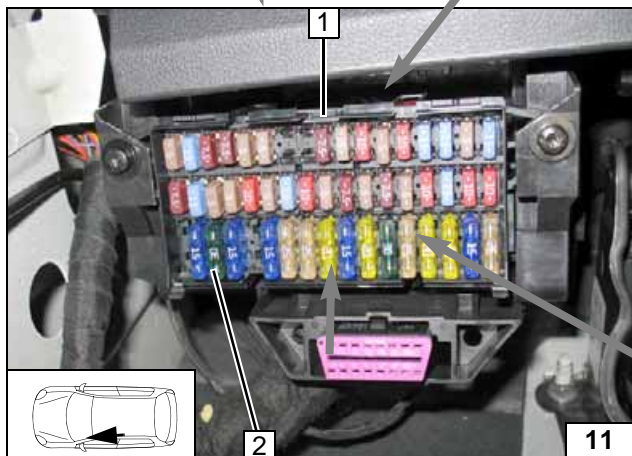

Loosen fuse and relay carrier 1.

- 2 Socket of fuse F37



Fuse and relay carrier

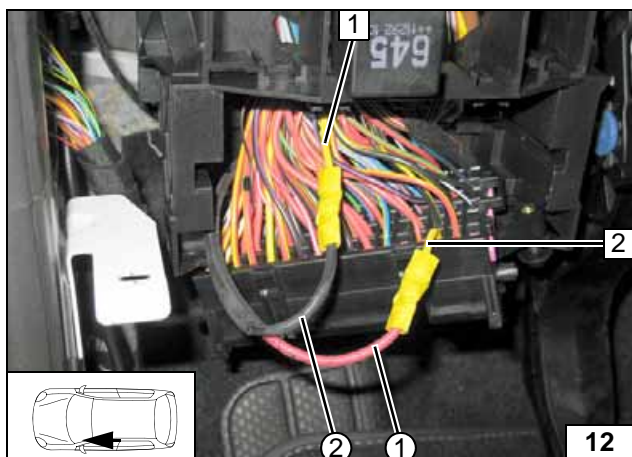

Connection to 30A fuse F37. Produce connections as shown in wiring diagram.

- 1 Yellow (ge) wire of fan switch E9
- 2 Yellow (ge) wire of fuse F37
- ① Red (rt) wire from K1/87a
- ② Black (sw) wire from K1/30



Connection of fan switch

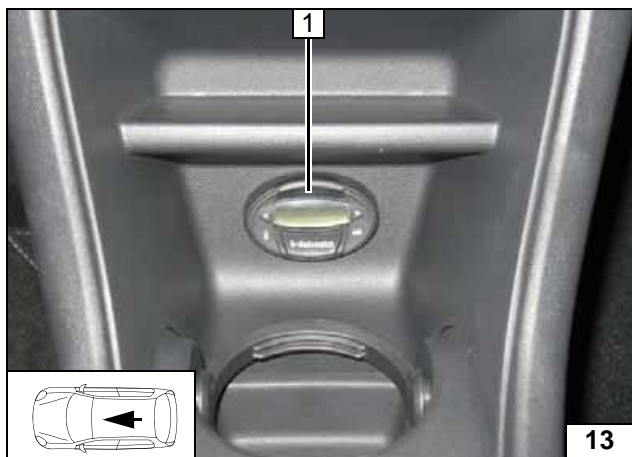

### Digital Timer

- 1 Digital timer



Installing digital timer

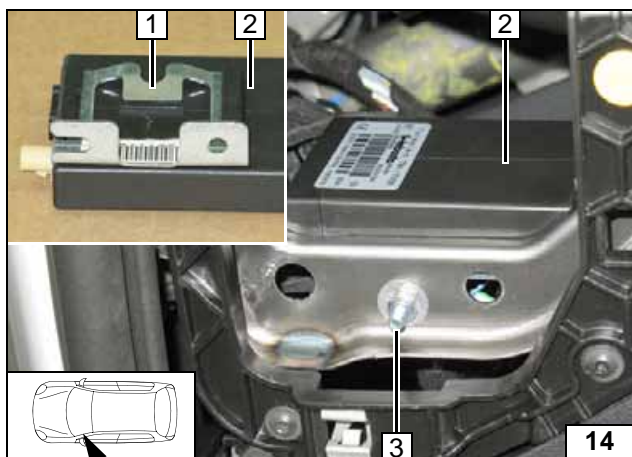

### Remote Option (Telestart)

Angle bracket 1 down by 90°.

- 2 Receiver
- 3 M5x16 bolt, large diameter washer [2x], nut, existing hole



Installing receiver

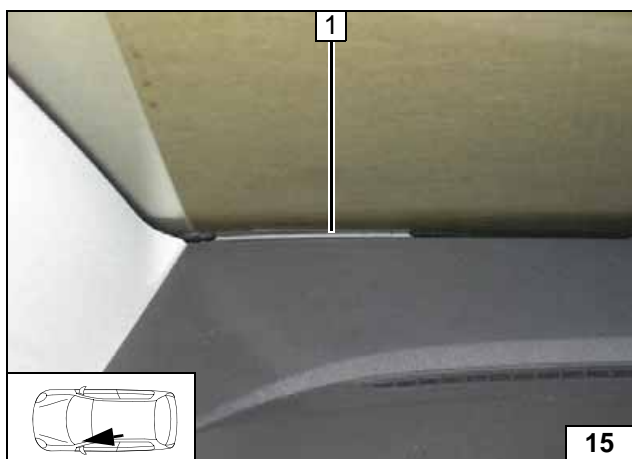

- 1 Antenna

Installing antenna

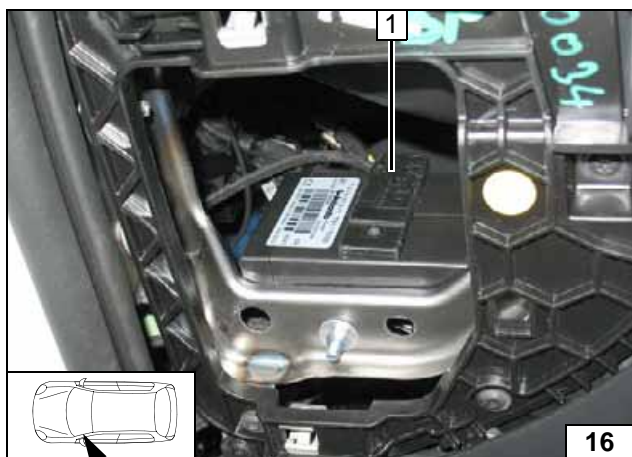

### Temperature sensor T100 HTM

Fasten temperature sensor 1 with adhesive tape.



Installing temperature sensor

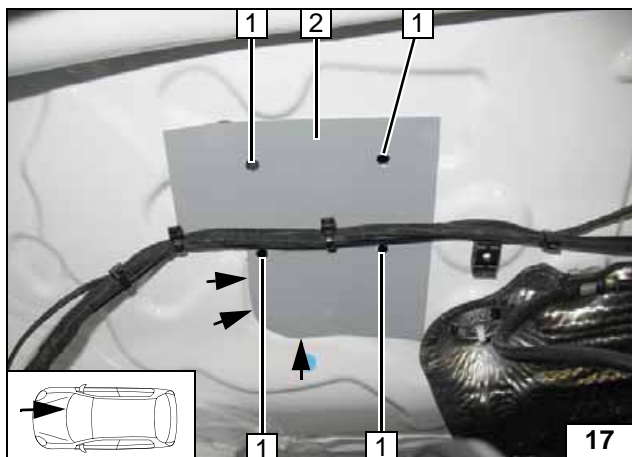

### Preparing Installation Location

Cut out template 2 and place it on the contours of the firewall.

- 1 Copy hole pattern [4x]



Copying hole pattern

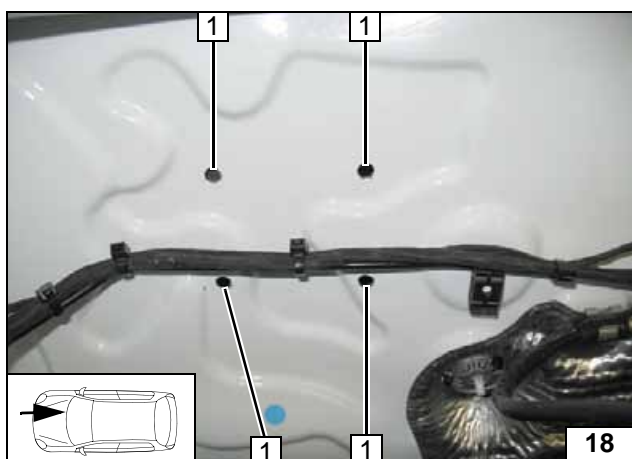

Remove template. Fold back insulation mat in the passenger compartment. When drilling, watch components located behind!

- 1 7mm dia. hole [4x]



Holes in firewall

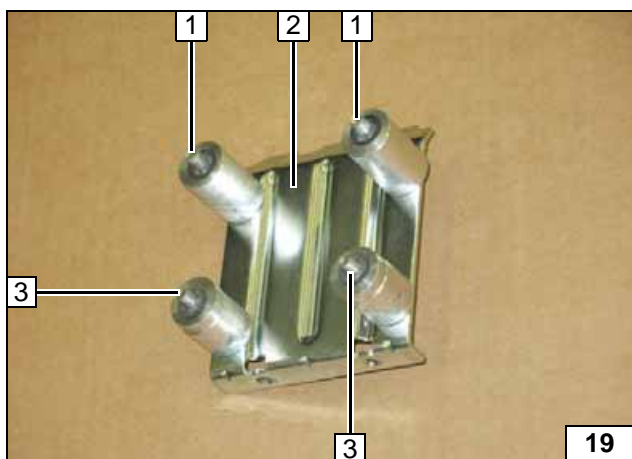

- 1 M6x40 bolt, 30mm shim, pin lock [2x each]
- 2 Bracket part A
- 3 M6x35 bolt, 20mm shim, 5mm shim, pin lock [2x each]

Preparing bracket part A

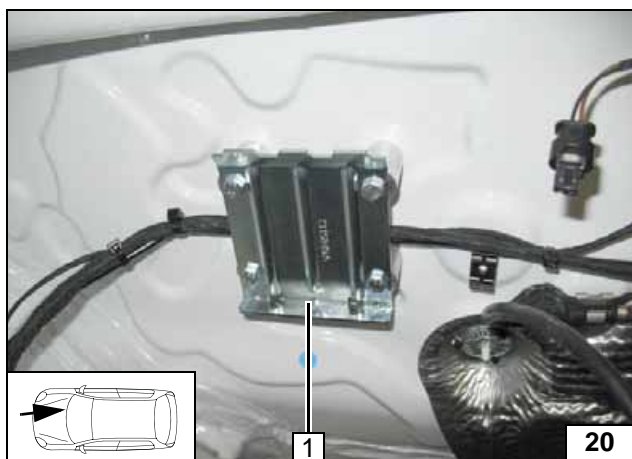

Ensure sufficient distance to brake line and wiring harnesses of heater / circulating pump.

- 1 Insert bracket



Installing bracket part A

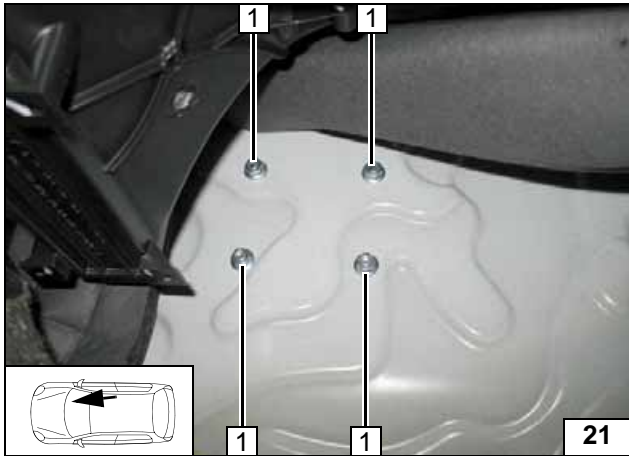

- 1 Flanged nut [4x]

Installing bracket part A

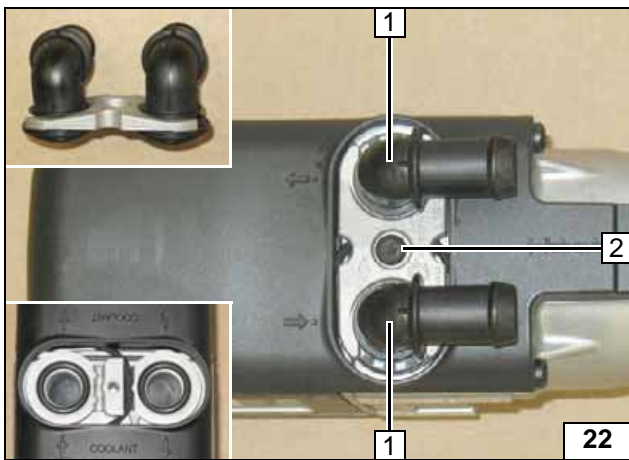

**Preparing Heater**

- 1 Water connecting piece, sealing ring [2x each]
- 2 5x15mm self-tapping bolt, retaining plate of water connecting piece



Installing water connecting piece

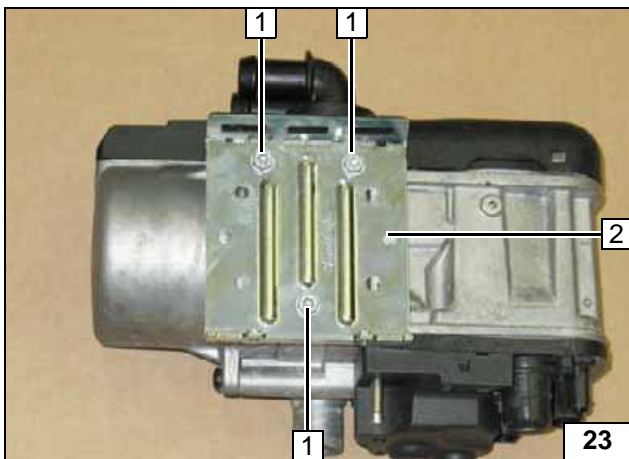

- 1 5x13 self-tapping bolt [3x]
- 2 Bracket part B

Premounting bracket part B



- 1 Combustion air pipe



Installing combustion air pipe

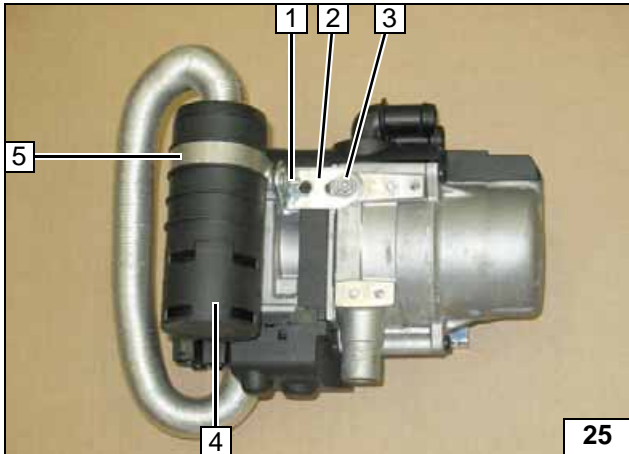

- 1 M5x16 bolt, flanged nut
- 2 Angle bracket
- 3 5x13 self-tapping bolt
- 4 Silencer
- 5 51mm dia. clamp

Installing silencer

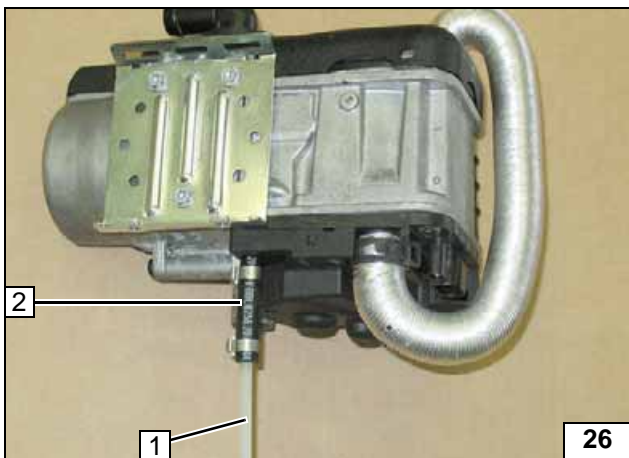

- 1 Fuel line
- 2 Hose section, 10 mm dia. clamp [2x]

Premounting fuel line

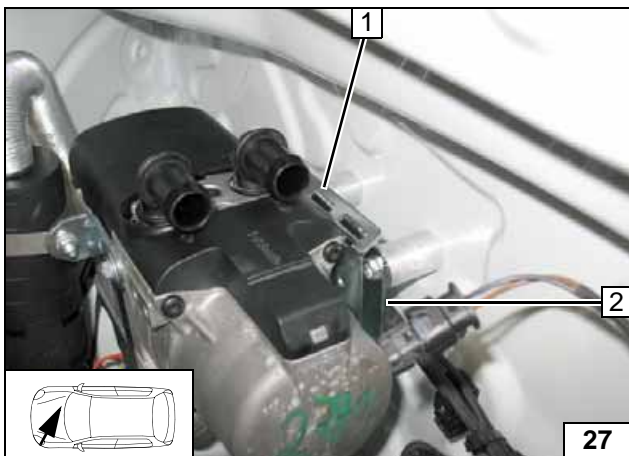

### Installing Heater

Insert heater with bracket **B** into premounted bracket **A**.

- 1 Bracket **B**
- 2 Bracket **A**

Installing heater

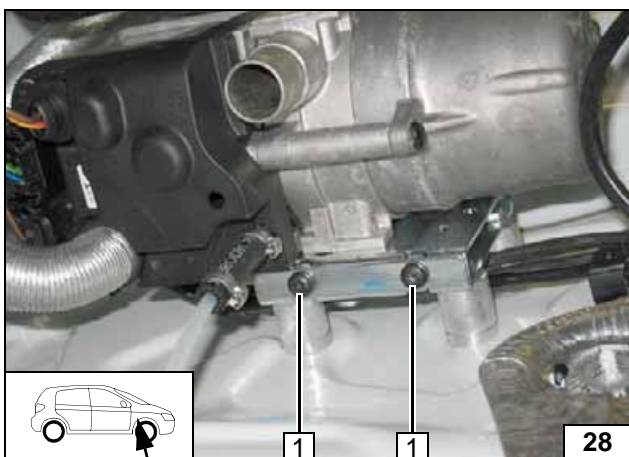

Bolt bracket **A** and bracket **B** together.

- 1 M5x12 Torx screw [2x]

Installing heater

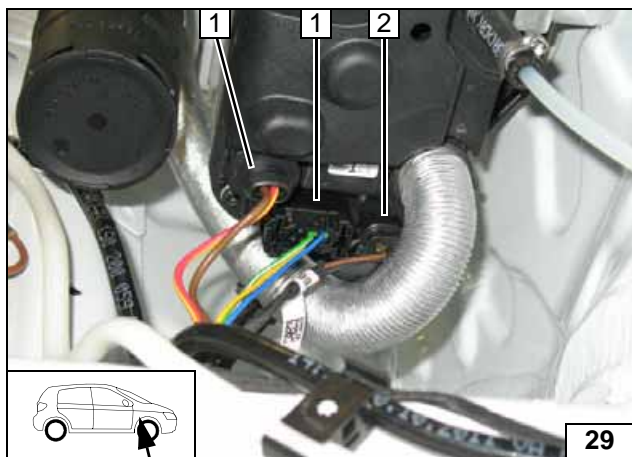

- 1 Wiring harness of heater [2x]
- 2 Wiring harness of circulating pump

Attaching  
wiring har-  
nesses

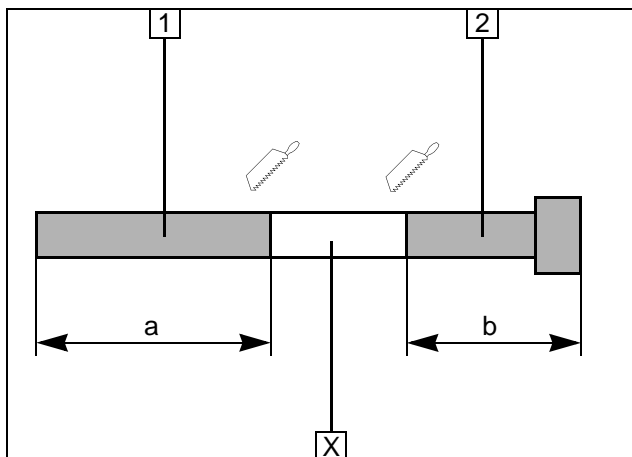
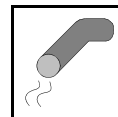

### Exhaust Gas

Discard section X.

- 1 Exhaust pipe  
a = 410
- 2 Exhaust end section  
b = 170

Preparing exhaust pipe

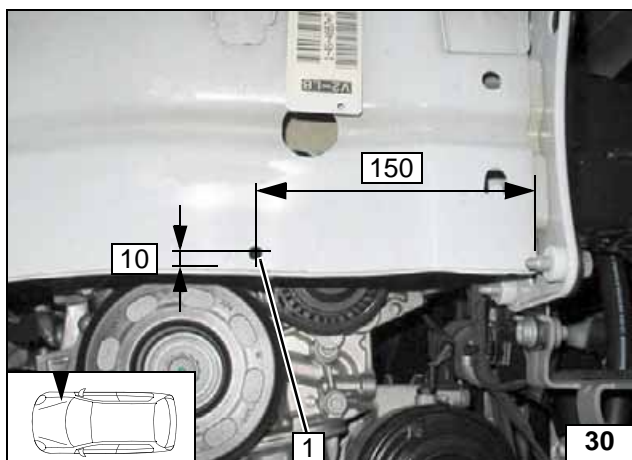

- 1 7mm dia. hole

Hole for silencer

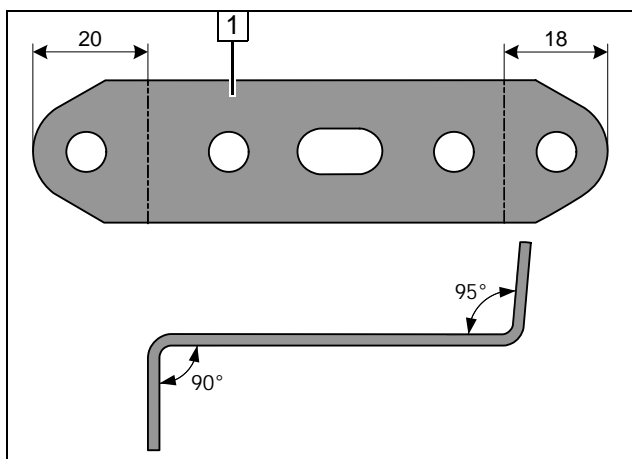

- 1 Perforated bracket

Angling down perforated bracket

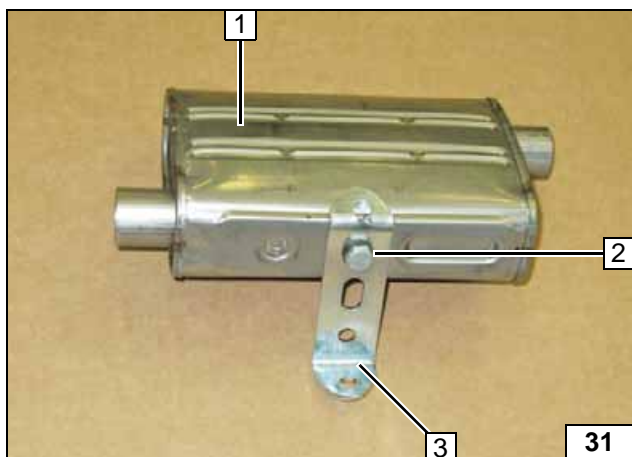

- 1 Silencer
- 2 M6x16 bolt, spring lockwasher
- 3 Perforated bracket

Premounting silencer

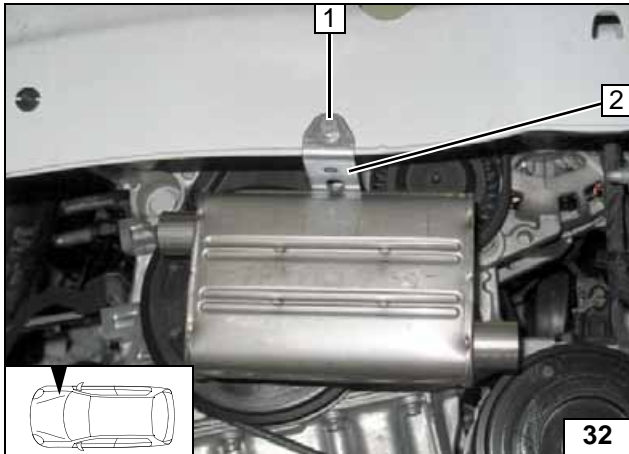

- 1 M6x20 bolt, flanged nut
- 2 Perforated bracket

**Installing silencer**

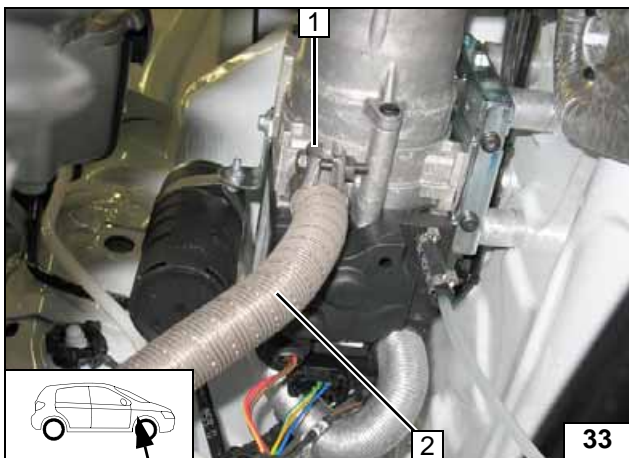

- 1 Hose clamp
- 2 Exhaust pipe

**Installing exhaust pipe**

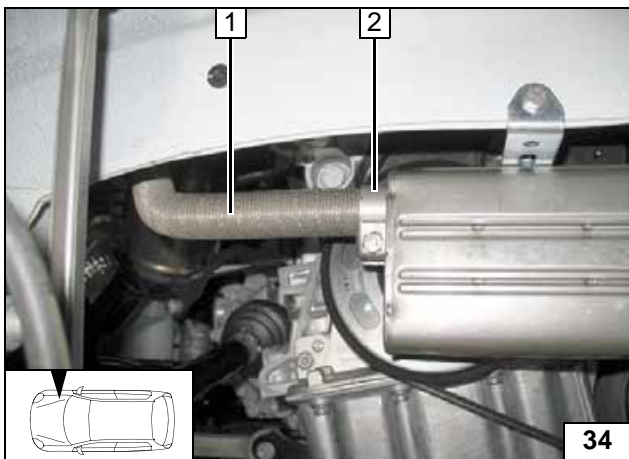

- 1 Exhaust pipe
- 2 Hose clamp

**Installing exhaust pipe**

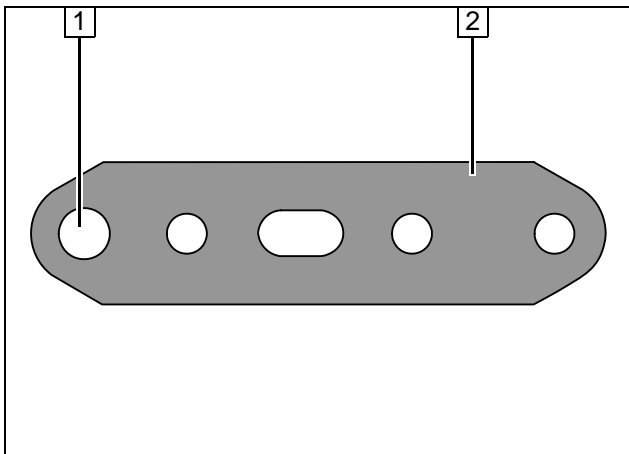

- 1 8.5mm dia. hole
- 2 Perforated bracket

**Drilling out perforated bracket**



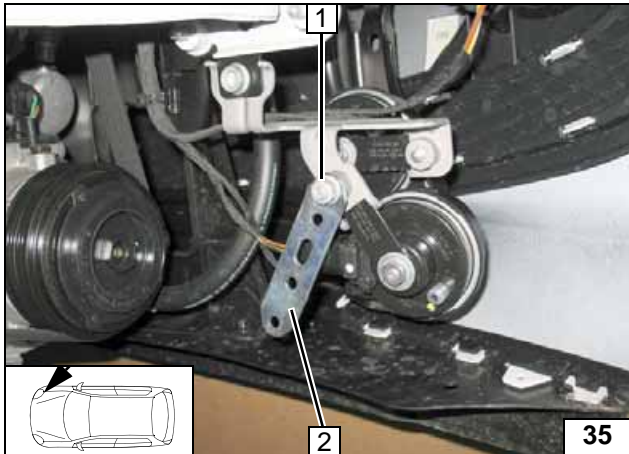

Remove original vehicle bolt (if present) at Position 1 and discard.

- 1 M8x30 bolt, flanged nut
- 2 Perforated bracket



**Installing perforated bracket**

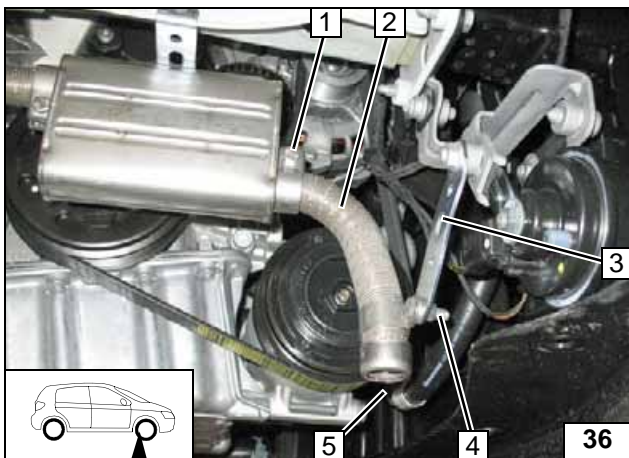

Ensure sufficient distance to neighbouring components, especially at position 5, correct if necessary.

- 1 Hose clamp
- 2 Exhaust end section
- 3 Perforated bracket
- 4 M6x20 bolt, p-clamp, flanged nut



**Installing exhaust end section**

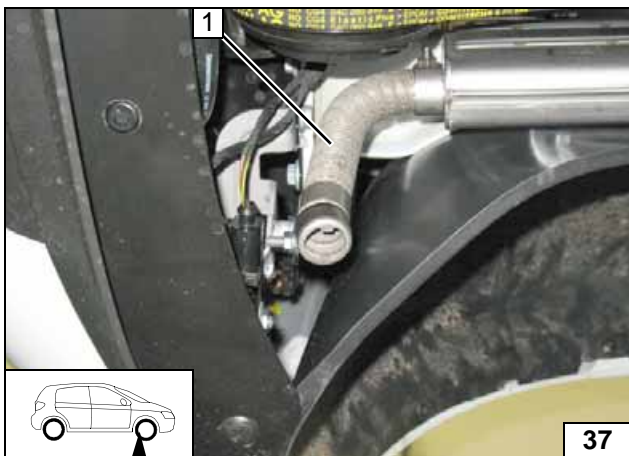

Ensure sufficient distance to neighbouring components, correct if necessary.

- 1 Exhaust end section



**Aligning exhaust end section**



**Fuel**

**CAUTION!**

Open the vehicle's fuel tank cap, ventilate the tank and then re-close the tank lock.

Catch any fuel running off with an appropriate container.

Install fuel line and metering pump wiring harness so that they are protected against stone impact. Unless specified otherwise, always fasten using cable ties.

Mount the fuel line and wiring harness with rub protection on sharp edges.

**WARNING!**

The fuel line and wiring harness are routed to the metering pump in as shown in the wiring harness routing diagram.

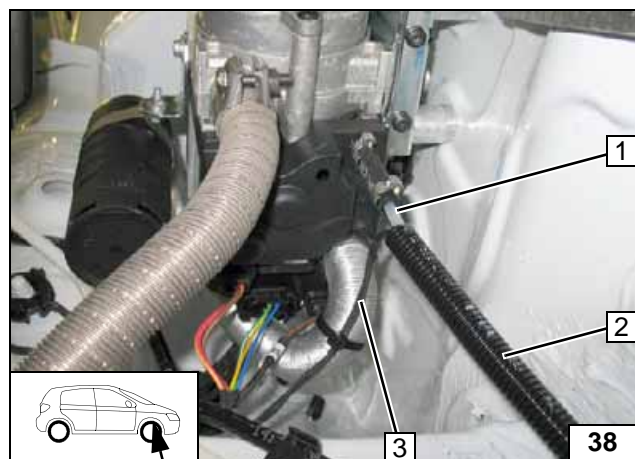

Route fuel line 1 and wiring harness of metering pump 3 to the underbody in 10mm dia. corrugated tube 2.

**Routing lines**



Route fuel line and wiring harness of metering pump in 10mm dia. corrugated tube 1 to the installation location of the metering pump along original vehicle lines.

**Routing lines**

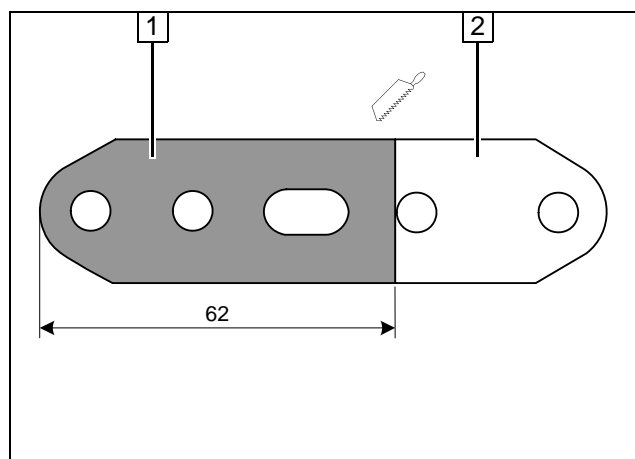

- 1 Perforated bracket
- 2 Discard section

**Cutting perforated bracket to length**

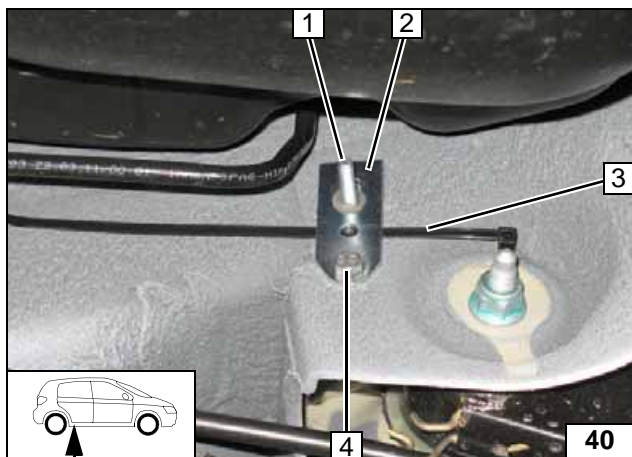

Insert cable tie 3 between perforated bracket 2 and body.

- 1 Premount M6x25 bolt, pin lock
- 4 M6x20 bolt, flanged nut, existing hole



**Installing perforated bracket**

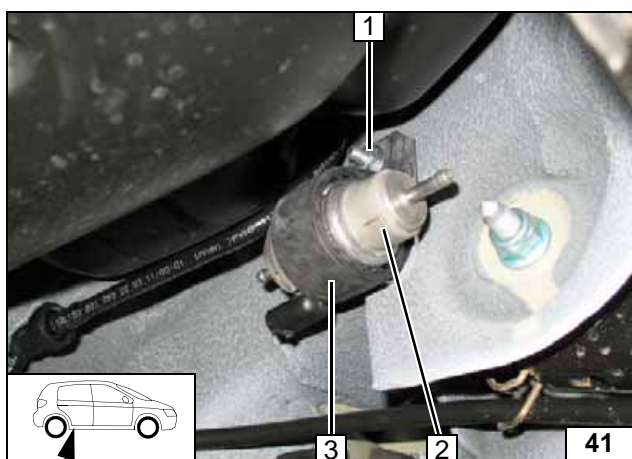

Close cable tie around metering pump mounting 3.

- 1 M6 flanged nut
- 2 Metering pump



**Installing metering pump**

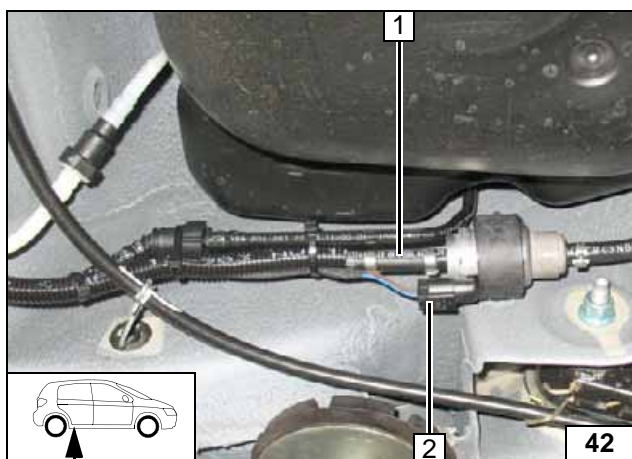

- 1 Fuel line of heater, hose section, 10mm dia. clamp [2x]
- 2 Wiring harness of metering pump, connector mounted

**Connecting metering pump**

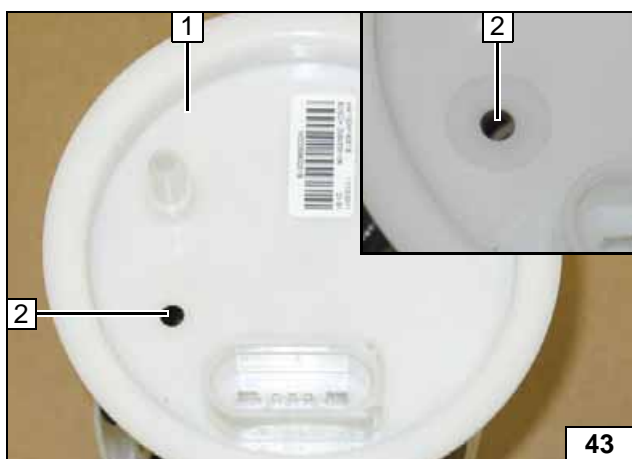

Remove fuel-tank sending unit 1 in accordance with manufacturer's instructions. 6mm dia. hole 2 centrally in stamping.



**Fuel extraction**

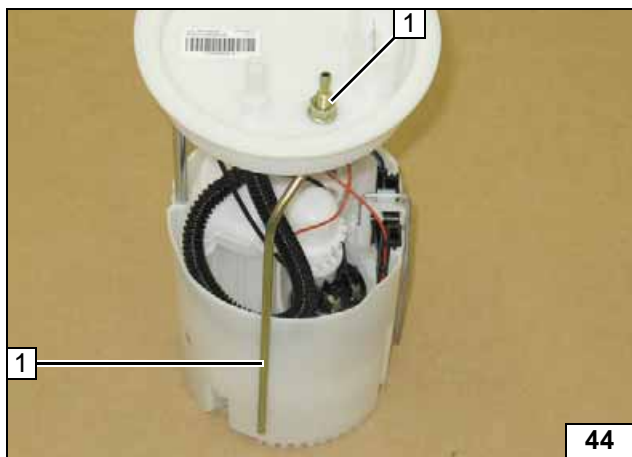

Shape fuel standpipe **1** according to template, cut to length and install.



**Installing fuel standpipe**



Install fuel-tank sending unit **3** in accordance with manufacturer's instructions.



**Connecting fuel line**

- 1** 90° moulded hose, 10mm dia. clamp [2x]
- 2** Fuel line
- 4** Fuel standpipe

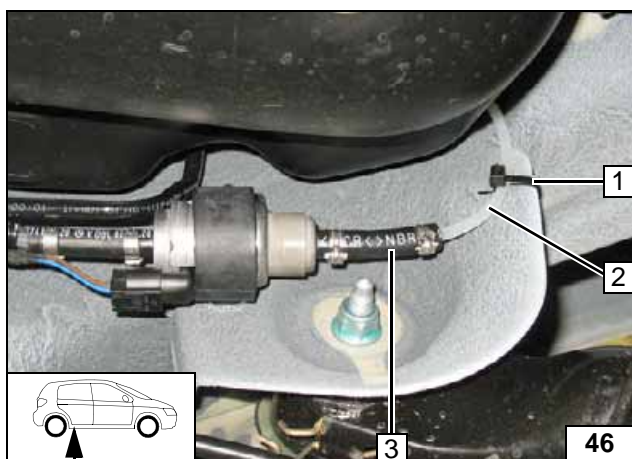

Check the position of the components; adjust if necessary. Check that they have freedom of movement.



**Connecting metering pump**

- 1** Cable tie through existing hole
- 2** fuel line, fuel standpipe
- 3** Hose section, 10 mm dia. clamp [2x]





## Coolant Circuit

### WARNING!

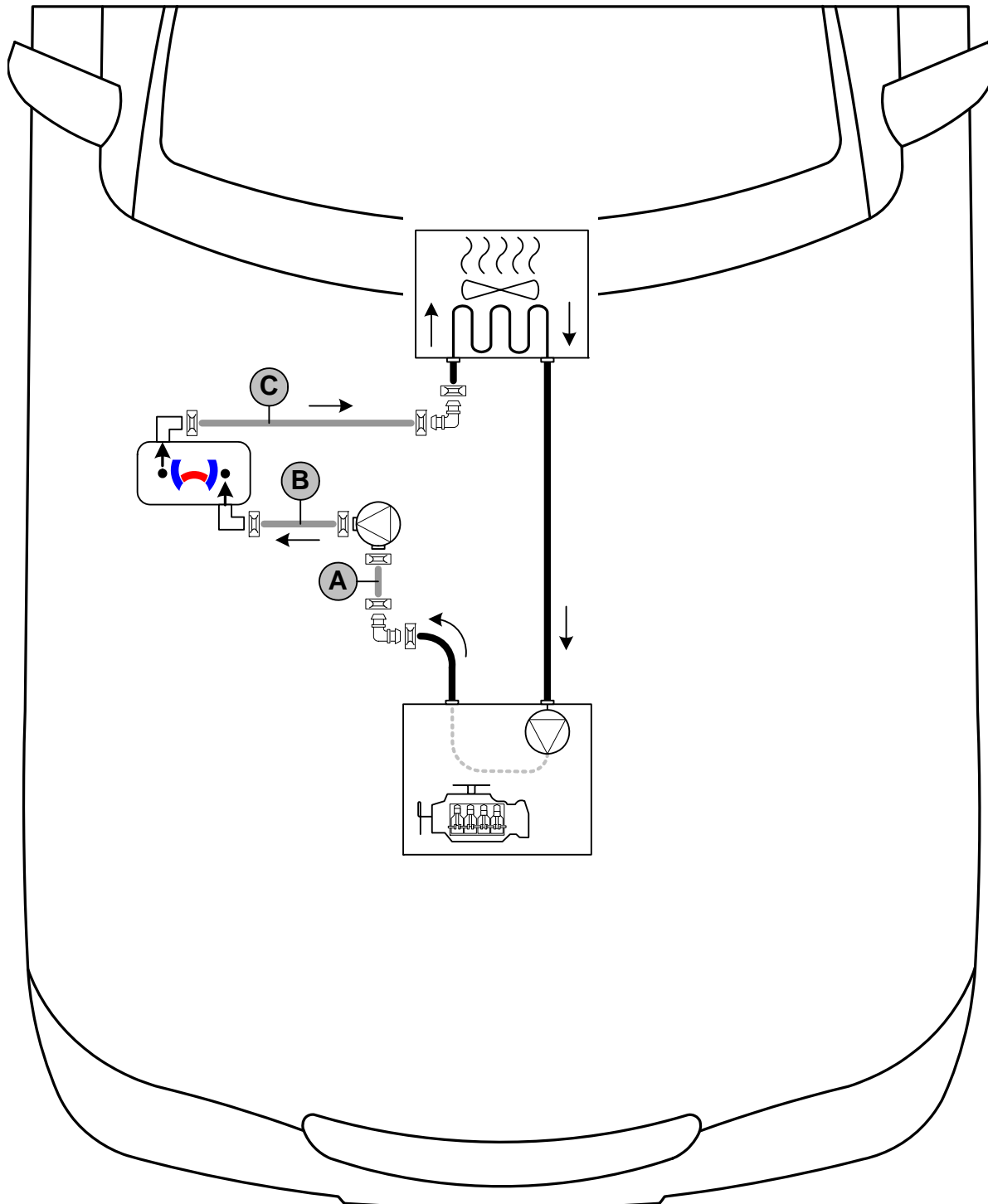
Any coolant running off should be collected using an appropriate container. Install hoses so that they are kink-free. Unless specified otherwise, always fasten using cable ties. Position clamps so that no other hose can be damaged! When installing the hoses, the heater must be filled with coolant. The connection should be "inline" based on the following diagram:



Hose routing diagram

All spring clips without a specific designation  = 25 mm dia.  
 All connecting pipes  = 18x18mm dia.



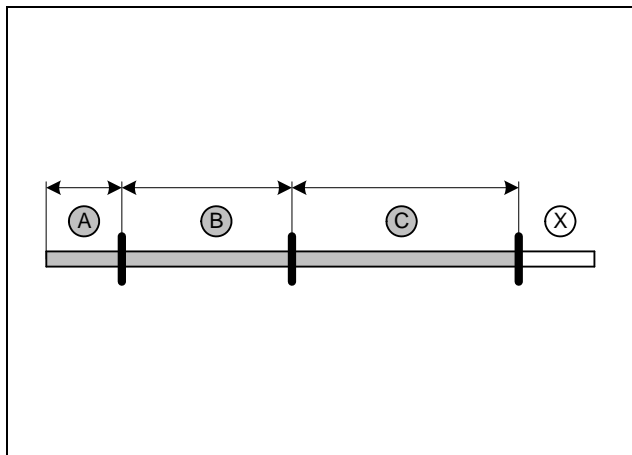

Discard section X.

- A = 60
- B = 210
- C = 370



**Cutting hoses to length**

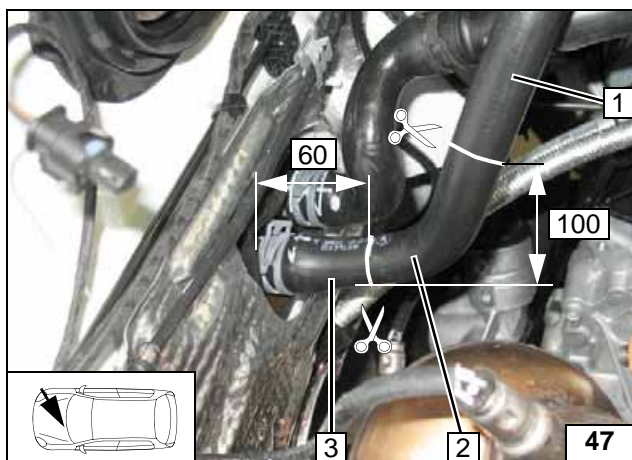

Image shows vehicle with hose of engine outlet on right heat exchanger connection. The positions of the hoses on the heat exchanger may vary. Cut off hose on engine outlet at the markings.



**Cutting point**

- 1 Engine outlet hose section
- 2 Discard section
- 3 Hose section of heat exchanger

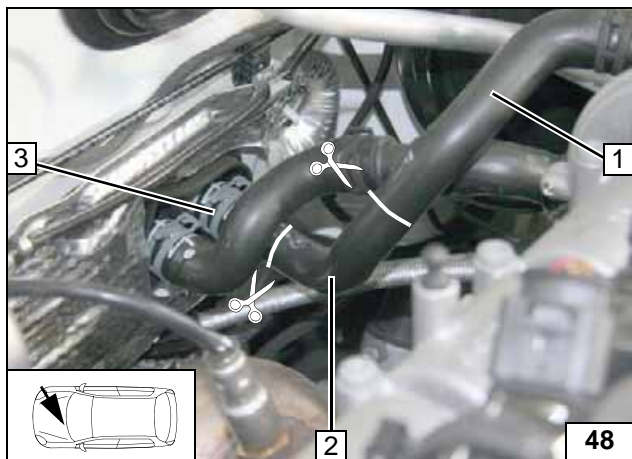
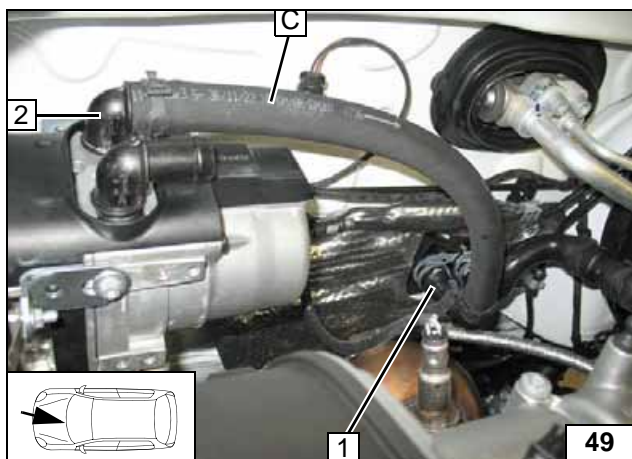

Image shows vehicle with hose of engine outlet on left heat exchanger connection. Separate hose of engine outlet at the markings (copy dimensions from previous image).



**Cutting point**

- 1 Engine outlet hose section
- 2 Discard section
- 3 Hose section of heat exchanger



In the following images, the connection is portrayed on the right side of the heat exchanger. In case of connection on the left side, act accordingly.



**Connection of heat exchanger inlet**

- 1 Hose on heat exchanger inlet
- 2 Connection piece of heater outlet

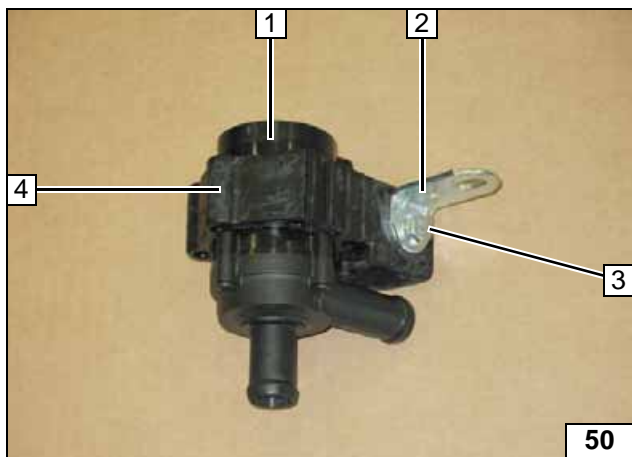

- 1 Circulating pump
- 2 Angle bracket
- 3 M6x25 bolt, flanged nut
- 4 Circulating pump mounting

**Premounting circulating pump**

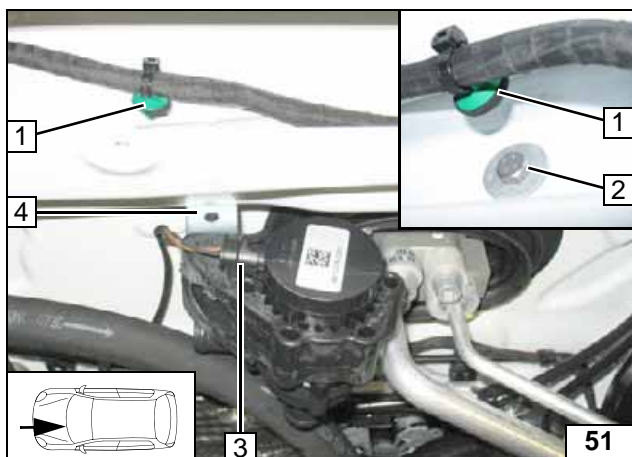

Detach retaining clip 1 from original vehicle wiring harness and fasten angle bracket 4 of circulating pump in hole.



- 2 M6x20 bolt, large diameter washer [2x], flanged nut
- 3 Mount wiring harness of circulating pump

**Installing circulating pump**

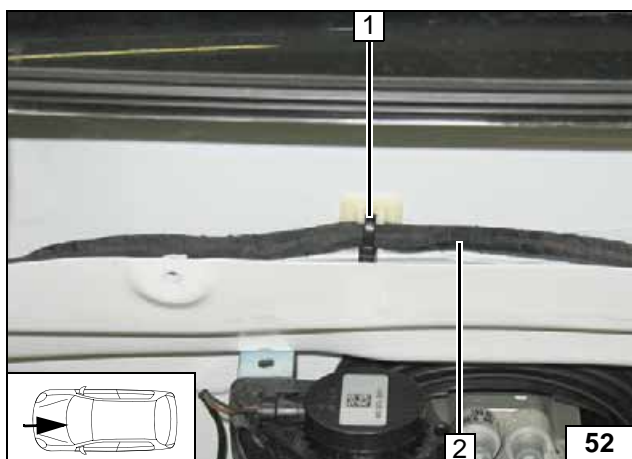

Clean adhesive surface.

- 1 Adhesive base with cable tie
- 2 Original vehicle wiring harness



**Fastening wiring harness**



- 1 Hose of engine outlet

**Connecting engine outlet**

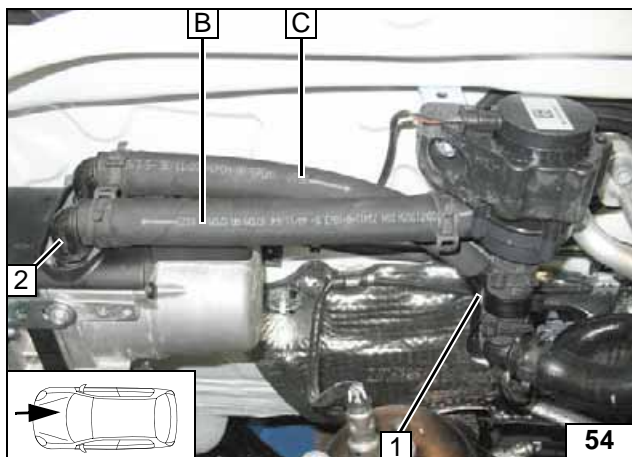

Align hoses. Insert spacer bracket **1** between hose **A** and **C**.  
Ensure sufficient distance to neighbouring components, correct if necessary.

- 1 Spacer bracket
- 2 Connection piece of heater inlet



**Connect-  
ing heater**



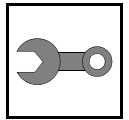

## Final Work

### WARNING!

Reassemble the disassembled components in reverse order. Check all hoses, clamps and all electrical connections for firm seating. Insulate all loose wires and tie back. Only use manufacturer-approved coolant. Spray the heater components with anti-corrosion wax (Tectyl 100K, Order No. 111329).



- **Connect the battery.**
- **Fill and bleed the coolant circuit according to the vehicle manufacturer's specifications.**
- **Adjust digital timer, teach Telestart transmitter.**
- **Make settings on A/C control panel according to the "Operating Instructions for End Customer".**
- **Place the instruction signboard "Switch off parking heater before refuelling" in the area of the filler neck.**
- **For initial start-up and function test, refer to installation instructions.**

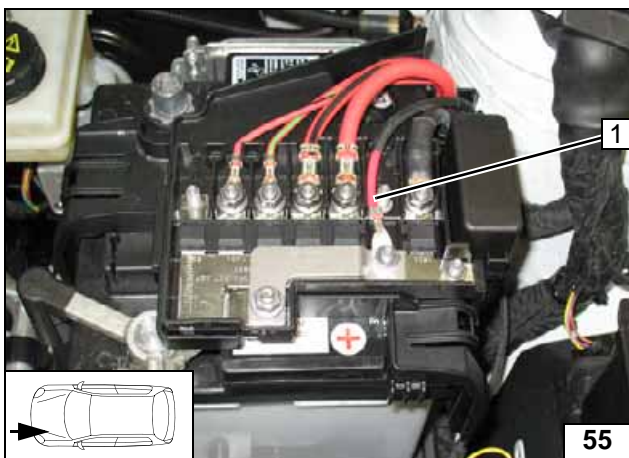

Connect positive wire 1 to original vehicle positive distributor.

**Connect-  
ing positive  
wire**

Webasto Thermo & Comfort SE  
Postfach 1410  
82199 Gilching  
Germany  
Internet: [www.webasto.com](http://www.webasto.com)  
Technical Extranet:  
<http://dealers.webasto.com>

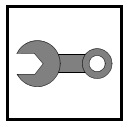

Template for Fuel Standpipe

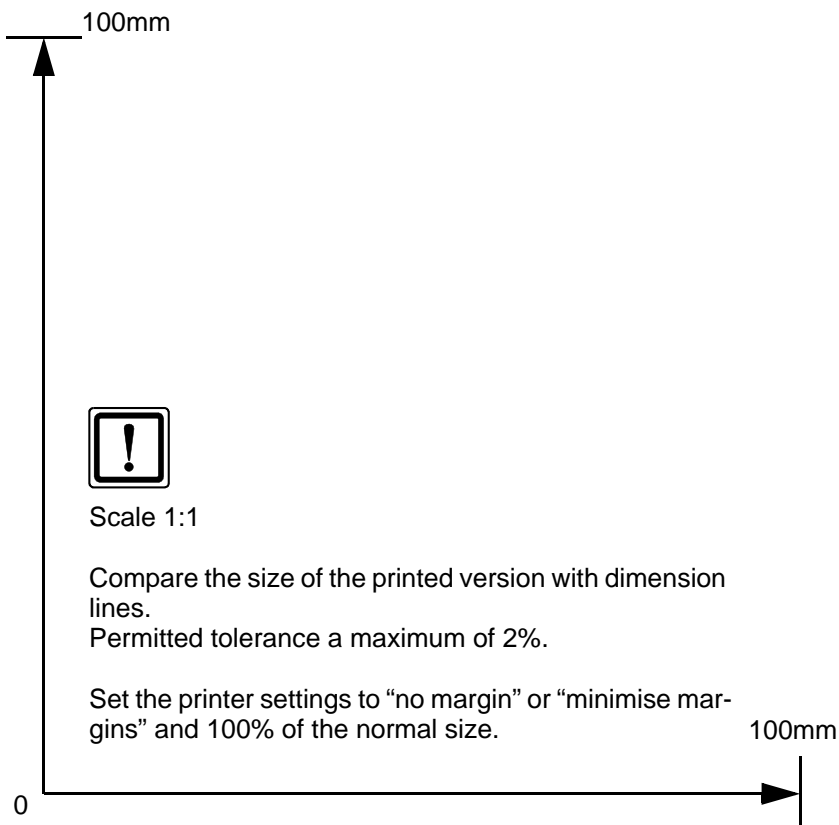



Drilling Template of Bracket

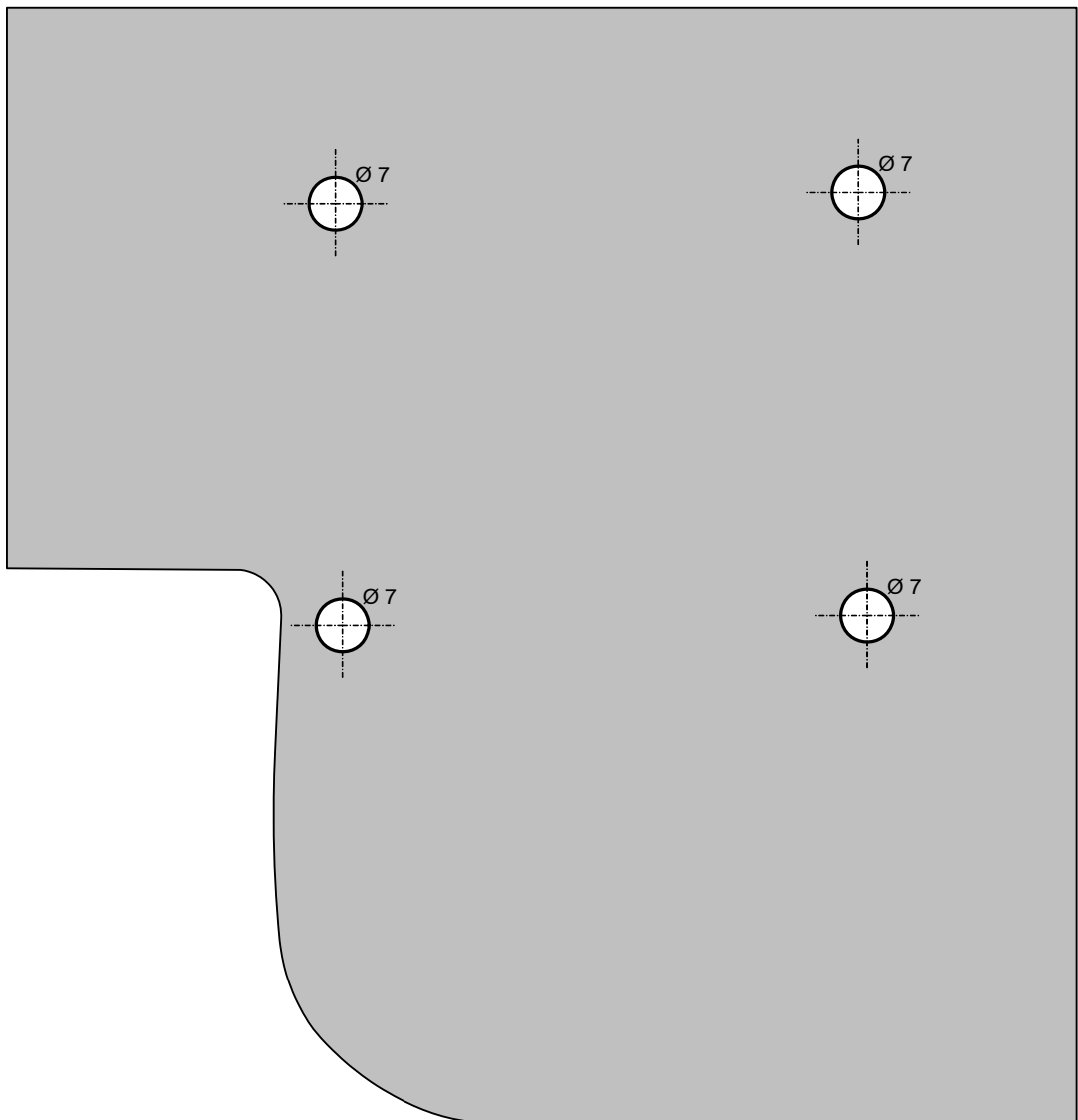

100mm



Scale 1:1

Compare the size of the printed version with dimension lines.  
Permitted tolerance a maximum of 2%.

Set the printer settings to "no margin" or "minimise margins" and 100% of the normal size.

100mm

0

## Operating Instructions for End Customer

Please remove this page in case of manual air-conditioning and add it to the vehicle operating instructions.

**Note:**

We recommend matching the heating time to the driving time.

Heating time = driving time

**Example:**

For a driving time of approx. 20 min. (in one direction), we recommend not exceeding a switch-on time of 20 min.

Passenger compartment monitoring, if installed, must be deactivated in addition to the vehicle settings for the heating operation.

For information on deactivation, please see the vehicle owner's manual.

Before parking the vehicle, make the following settings:

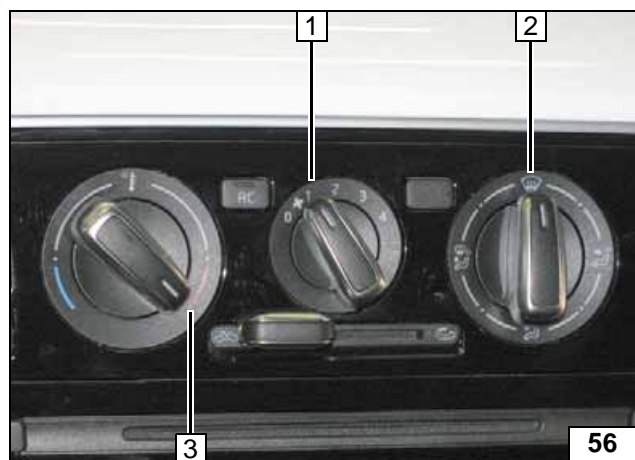

- 1 Set fan to level "1", max. "2"
- 2 Direct air outlet towards windscreen
- 3 Set temperature to "max."

A/C control panel

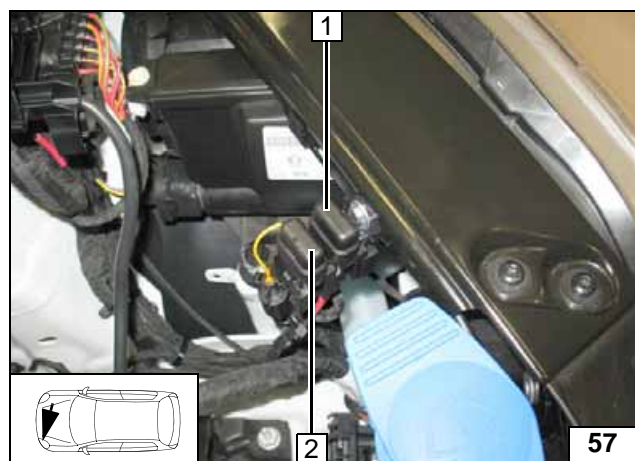

- 1 30A main fuse F2 of passenger compartment
- 2 20A heater fuse F1

Fuses of engine compartment

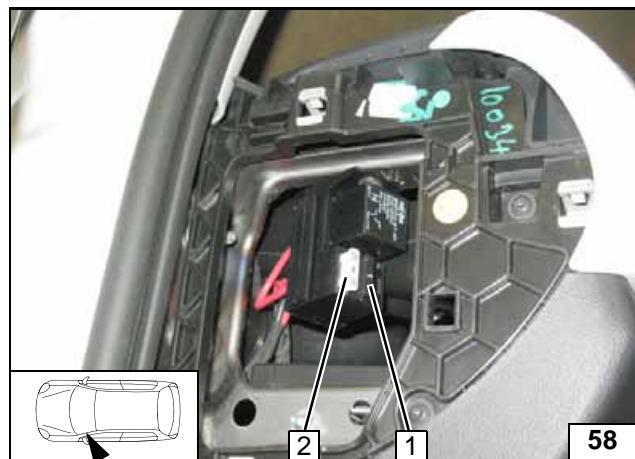

- 1 1A fuse F3 of heater control
- 2 25A fan fuse F4

Fuses of passenger compartment

