

Water Heater

Thermo Top Evo Parking Heater



Installation Documentation Hyundai i40

Validity

Manufacturer	Model	Type	EG-BE No. / ABE
Hyundai	i40	VF	e4 * 2007 / 46 * 0263 * ...

Motorisation	Fuel	Transmission type	Output in kW	Displacement in cm ³	Engine code
1.7 CRDi	Diesel	6-speed AG	100	1685	D4FD

AG = automatic transmission

From model year 2011
Left-hand drive vehicle

Verified equipment variants: Manual / automatic air-conditioning system
Front fog lights
Headlight washer system
Xenon

Not verified: Passenger compartment monitoring

Total installation time: approx. 9.5 hours

Table of Contents

Validity	1	Thermo Call Option	14
Necessary Components	2	Preparing Installation Location	15
Installation Overview	2	Preparing Heater	15
Information on Total Installation Time	2	Installing Heater	18
Information on Operating and Installation Instructions	3	Combustion Air	20
Information on Validity	4	Coolant Circuit	21
Technical Information	4	Fuel	25
Explanatory Notes on Document	4	Exhaust Gas	29
Preliminary Work	5	Final Work	30
Heater Installation Location	5	Template for Fuel Standpipe	31
Preparing Electrical System	6	Operating Instructions for Manual Air-Conditioning	32
Electrical System	7	Operating Instructions for Automatic Air-Conditioning	33
Installing Passenger Compartment Relay and Fuse Holder	8		
Fan Controller for Manual Air-Conditioning	9		
Fan Controller for Automatic Air-Conditioning	11		
MultiControl CAR Option	13		
Remote Option (Telestart)	13		

Necessary Components

- Basic delivery scope of *Thermo Top Evo* based on price list
- Installation kit for Hyundai i40 2011 Diesel: **1318408C**
- Heater control in accordance with price list and upon consultation with end customer
- In case of Telestart, indicator lamp in accordance with price list and in consultation with end customer

Installation instructions:

- Arrange for the vehicle to be delivered with the tank only about ¼ full.
- The installation location of the push button in case of Telestart or Thermo Call should be confirmed with the end customer.
- Depending on the space required and the vehicle manufacturer's instructions, we recommend the use of a vehicle battery with a higher electrical capacity.

Installation Overview

Legend:

1. Heater
2. Engine compartment fuse holder
3. Passenger compartment relay and fuse holder
4. Circulating pump
5. MultiControl CAR
6. Metering pump

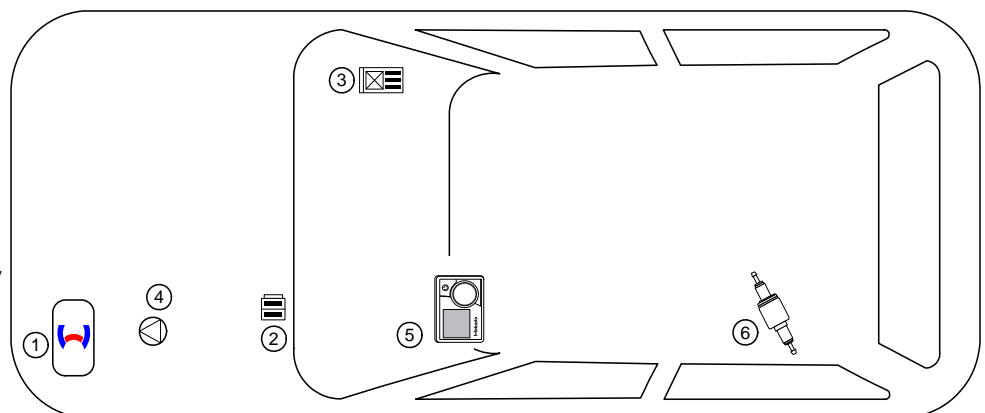

Information on Total Installation Time

The total installation time includes the time needed for mounting and demounting the vehicle-specific components, the heater specific installation time and all other times required for the system integration and initial start-up of the heater.

The total installation time may vary for vehicle equipment other than provided.

Information on Operating and Installation Instructions

1 Important information (not complete)

1.1 Installation and repair



The improper installation or repair of Webasto heating and cooling systems can cause fire or the leakage of deadly carbon monoxide, leading to serious injury or death.



To install and repair Webasto heating and cooling systems you need to have completed a special company training course and have the appropriate technical documentation, special tools and special equipment.



Installation and repair may ONLY be carried out by persons trained and certified in a Webasto training course. NEVER try to install or repair Webasto heating or cooling systems if you have not completed a Webasto training course, you do not have the necessary technical skills and you do not have the technical documentation, tools and equipment available to ensure that you can complete the installation and repair work properly.

Only use genuine Webasto parts. See the Webasto air and water heaters accessories catalogue for this purpose.

1.2 Operation

To ensure safe operation, we recommend having the heater checked every two years by an authorised Webasto dealer, especially when used over a long period and/or under extreme environmental conditions.

Do not operate the heater in closed rooms due to the danger of poisoning and suffocation.

Always switch off the heater before refuelling.

The heater may only be used with the prescribed fuel diesel (DIN EN 590) or petrol (DIN EN 228).

The heater may not be cleaned with a high-pressure cleaner.

1.3 Please note

ALWAYS follow all Webasto installation and operating instructions and observe all warnings.

To become familiar with and understand all functions and properties of the heater, the operating instructions must be read carefully and observed at all times.

For proper, safe installation and repair work, the installation instructions with all warnings and safety information must be carefully read and observed at all times. Please always contact a workshop authorised by Webasto for all installation and repair work.

Important

Webasto shall assume no liability for defects, damage and injuries resulting from a failure to observe the installation, repair and operating instructions of the information contained in them.

This liability exclusion particularly applies to improper installations and repairs, installations and repairs by untrained persons or in the case of a failure to use genuine spare parts.

The liability due to culpable disregard to life, limb or health and due to damage or injuries caused by a wilful or reckless breach of duty remain unaffected, as does the obligatory product liability.

Installation should be carried out according to the general, standard rules of technology. Unless specified otherwise, fasten hoses, lines and wiring harnesses to original vehicle lines and wiring harnesses using cable ties. Insulate loose wire ends and tie back. Connectors on electronic components have to audibly click into place during installation.

Sharp edges should be fitted with rub protection. Spray unfinished body areas, e.g. drilled holes, with anti-corrosion wax (Tectyl 100K).

Observe the instructions and guidelines of the respective vehicle manufacturer for demounting and mounting vehicle specific components!

The initial startup is to be executed with the Webasto Thermo Test Diagnosis.

When installing a programmable control module (e.g. a PWM Gateway), the corresponding settings must be checked or adjusted.

2 Statutory regulations governing installation

Guidelines	Thermo Top Evo
Heating Directive ECE R122	E1 00 0258
EMC Directive ECE R10	E1 04 5627

Note

The regulations of these guidelines are binding in the scope of the Directive 70/156/EEC and/or 2007/46/EC (for new vehicle models from 29/04/2009) and should also be observed in countries in which there are no special regulations.

Important

Failure to follow the installation instructions will result in the invalidation of the type approval for the heater and therefore invalidation of the general **homologation of the vehicle**.

Note

The heater is licensed in accordance with paragraph 19, section 3, No. 2b of the StVZO (German Road Traffic Licensing Authority).

2.1 Excerpt from ECE regulation 122 (heating system) paragraph 5 for the installation of the heater

Beginning of excerpt.

ANNEX VII

REQUIREMENTS FOR COMBUSTION HEATERS AND THEIR INSTALLATION

1. GENERAL REQUIREMENTS

1.7.1. A clearly visible tell-tale in the operator's field of view shall inform when the combustion heater is switched on or off.

2. VEHICLE INSTALLATION REQUIREMENTS

2.1. Scope

2.1.1. Subject to paragraph 2.1.2, combustion heaters shall be installed according to the requirements of this Annex.

2.1.2. Vehicles of category O having liquid fuel heaters are deemed to comply with the requirements of this Annex.

2.2. Positioning of heater

2.2.1. Body sections and any other components in the vicinity of the heater must be protected from excessive heat and the possibility of fuel or oil contamination.

2.2.2. The combustion heater shall not constitute a risk of fire, even in the case of overheating. This requirement shall be deemed to be fulfilled if the installation ensures an adequate distance to all parts and suitable ventilation, by the use of fire resistant materials or by the use of heat shields.

2.2.3. In the case of M2 and M3 vehicles, the heater must not be positioned in the passenger compartment. However, an installation in an effectively sealed envelope which also complies with the conditions in paragraph 2.2.2 may be used.

2.2.4. The label referred to in paragraph 1.4 or a duplicate, must be positioned so that it can be easily read when the heater is installed in the vehicle.

2.2.5. Every reasonable precaution should be taken in positioning the heater to minimise the risk of injury and damage to personal property.

2.3. Fuel supply

2.3.1. The fuel filler must not be situated in the passenger compartment and must be provided with an effective cap to prevent fuel spillage.

2.3.2. In the case of liquid fuel heaters, where a supply separate to that of the vehicle is provided, the type of fuel and its filler point must be clearly labelled.

2.3.3. A notice, indicating that the heater must be shut down before refuelling, must be affixed to the fuelling point. In addition a suitable instruction must be included in the manufacturer's operating manual.

2.4. Exhaust system

2.4.1. The exhaust outlet must be located so as to prevent emissions from entering the vehicle through ventilators, heated air inlets or opening windows.

2.5. Combustion air inlet

2.5.1. The air for the combustion chamber of the heater must not be drawn from the passenger compartment of the vehicle.

2.5.2. The air inlet must be so positioned or guarded that blocking by rubbish or luggage is unlikely.

2.6. Heating air inlet

2.6.1. The heating air supply may be fresh or recirculated air and must be drawn from a clean area not likely to be contaminated by exhaust fumes emitted either by the propulsion engine, the combustion heater or any other vehicle source.

2.6.2. The inlet duct must be protected by mesh or other suitable means.

2.7. Heating air outlet

2.7.1. Any ducting used to route the hot air through the vehicle must be so positioned or protected that no injury or damage could be caused if it were to be touched.

2.7.2. The air outlet must be so positioned or guarded that blocking by rubbish or luggage is unlikely.

End of excerpt.

In multilingual versions the German language is binding.

Hyundai i40

Information on Validity

This installation documentation applies to Hyundai i40 Diesel vehicles - for validity, see page 1 - from model year 2011 and later, assuming technical modifications to the vehicle do not affect installation, any liability claims excluded. Depending on the vehicle version and equipment, modifications may be necessary during installation with respect to this 'installation documentation'.

Vehicle and engine types, equipment variants and other specifications not listed in this installation documentation have not been tested. However, installation according to this installation documentation may be possible.

Technical Information

Special Tools

- Hose clamp pliers for auto-tightening hose clamps
- Hose clamp pliers for Clic hose clamps of type W
- Automatic wire stripper 0.2 - 6mm²
- Crimping pliers for cable lug / tab connector 0.5 - 6mm²
- Torque wrench for 2.0 - 10 Nm
- Hose clamping pliers
- Deep-hole marker
- Webasto Thermo Test Diagnosis with current software

Dimensions

- All dimensions are in mm.















Tightening torque values

- Tightening torque values of 5x13 heater bolts and 5x11 heater stud bolts = 8Nm.
- Tightening torque value of 5x15 water connection piece retaining plate bolt = 7Nm.
- Tighten other bolt connections in accordance with manufacturer's instructions or in accordance with state-of-the-art-technology.

Explanatory Notes on Document

You will find an identification mark on the outside top right corner of the page in question to provide you with a quick overview of the individual working steps.

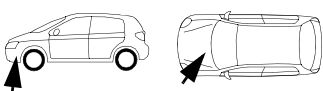
Special features are highlighted using the following symbols:

Mechanical System		Specific risk of damage to components.	
Electrical System		Specific risk due to electrical voltage.	
Coolant Circuit		Specific risk of injury or fatal accidents.	
Combustion Air		Specific risk of fire or explosion.	
Fuel		Reference to the manufacturer's vehicle-specific documents or to the general installation instructions of Webasto components.	
Exhaust Gas		Reference to a special technical feature.	
Software		The arrow in the vehicle icon indicates the position on the vehicle and the viewing angle.	
		Tightening torque according to the manufacturer's vehicle-specific documents.	

Hyundai i40

Preliminary Work

Vehicle

- Open the fuel tank cap.
- Ventilate the fuel tank.
- Close the fuel tank cap again.
- Depressurise the cooling system.
- Disconnect and completely remove the battery together with the carrier.
- Remove the air filter.
- Remove the engine control unit.
- Remove the bumper trim.
- Remove the wheel well trim on the left-hand side.
- Remove the front underride protection.
- Remove the underbody trim (fuel line cover) on the left.
- Open the right-hand tank-fitting service lid (boot).
- Remove the fuel tank sending unit in accordance with the manufacturer's instructions.
- Remove the footwell trim on the front passenger's side.
- Remove the A-pillar trim in the footwell on the front passenger's side (only with Telestart).
- Remove the glove box and the trim behind.
- Remove the A/C control panel according to the manufacturer's instructions.

Heater

- Remove years that do not apply from the type and duplicate label.
- Attach the duplicate label (type label) visibly in the appropriate place in the engine compartment.



Heater Installation Location

1 Heater

Installation location

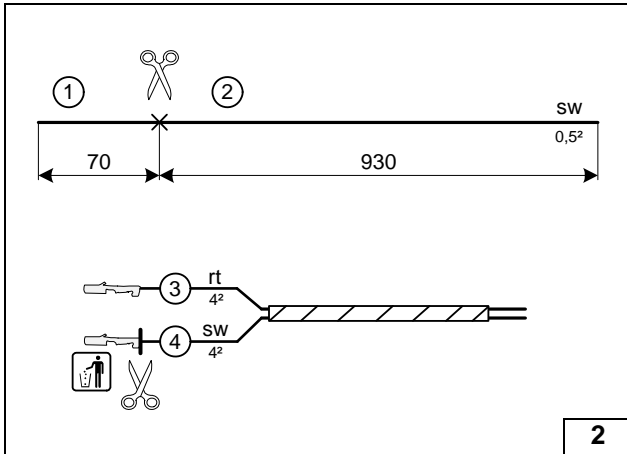

Preparing Electrical System

Wire sections retain their numbering in the entire document.

Produce all following electrical connections as shown in the wiring diagram.

Pull wire section ② into provided protective sleeving.

- ③ Red (rt) wire of fan wiring harness
- ④ Black (sw) wire of fan wiring harness



Cutting to length / assigning wires

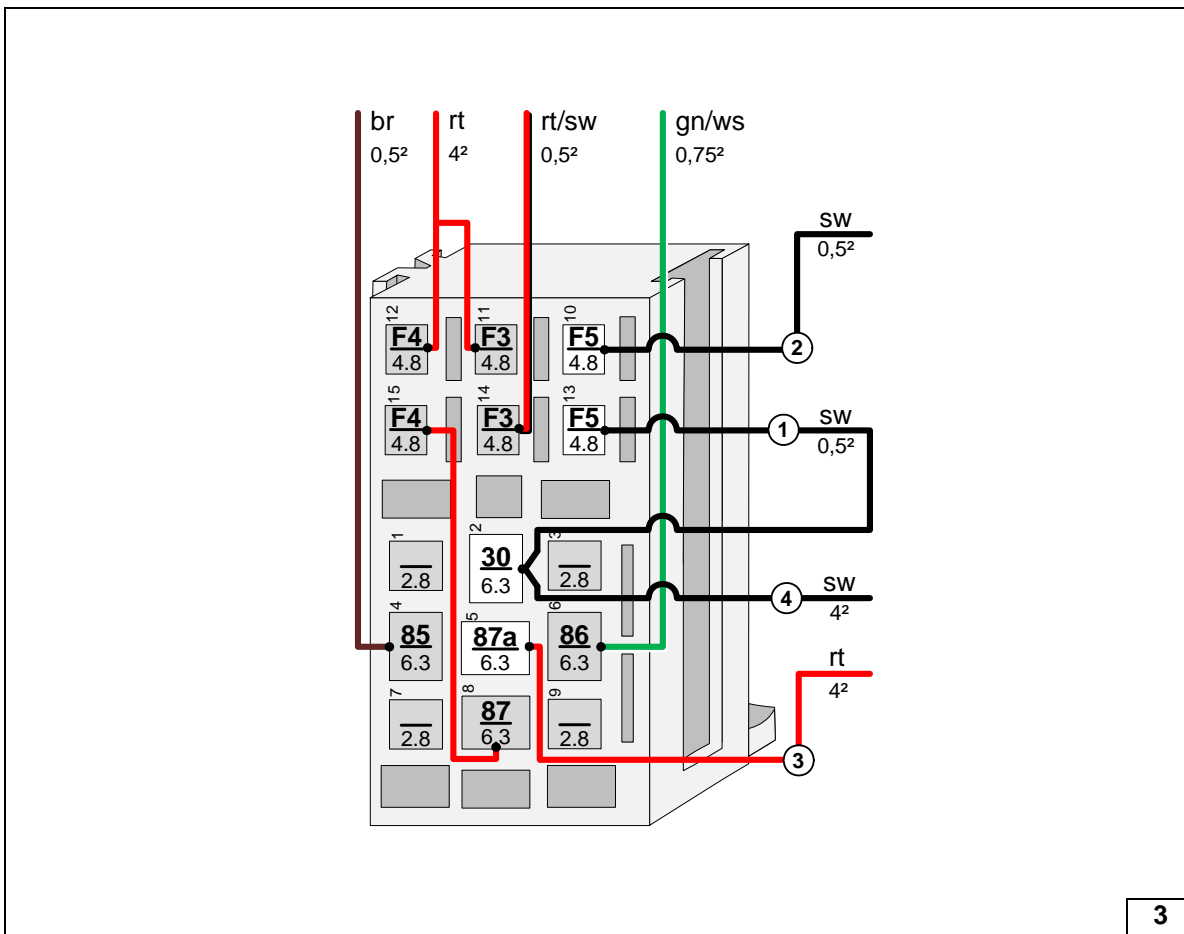

Connecting wires to socket of passenger compartment relay and fuse holder

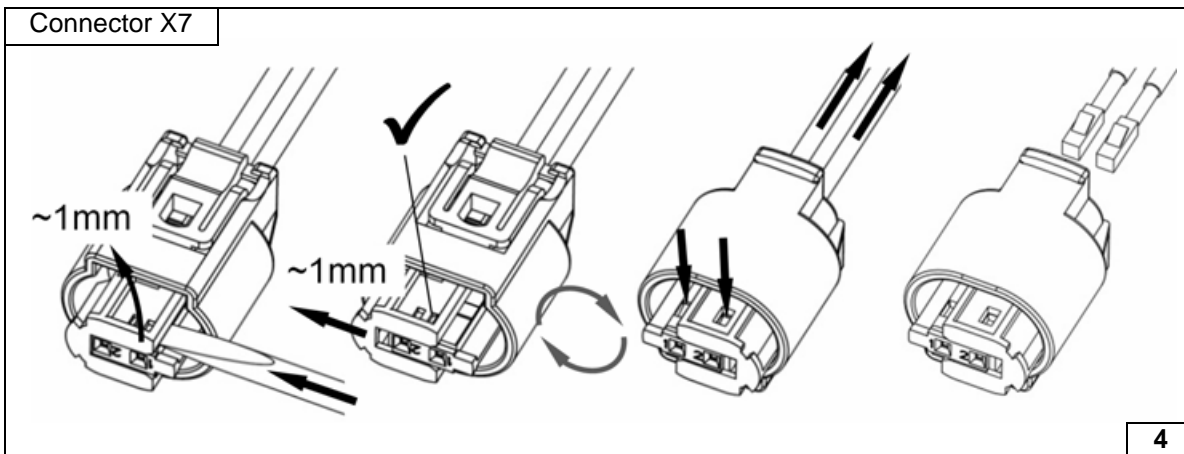

Dismantling metering pump connector



Electrical System

Earth wire

- 1 Earth wire on original vehicle earth support point

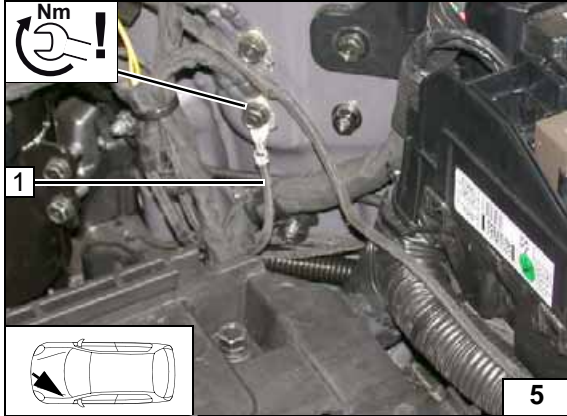

Wiring harness pass through

- 1 Protective rubber plug
- 2 Wiring harnesses of heater, heater control

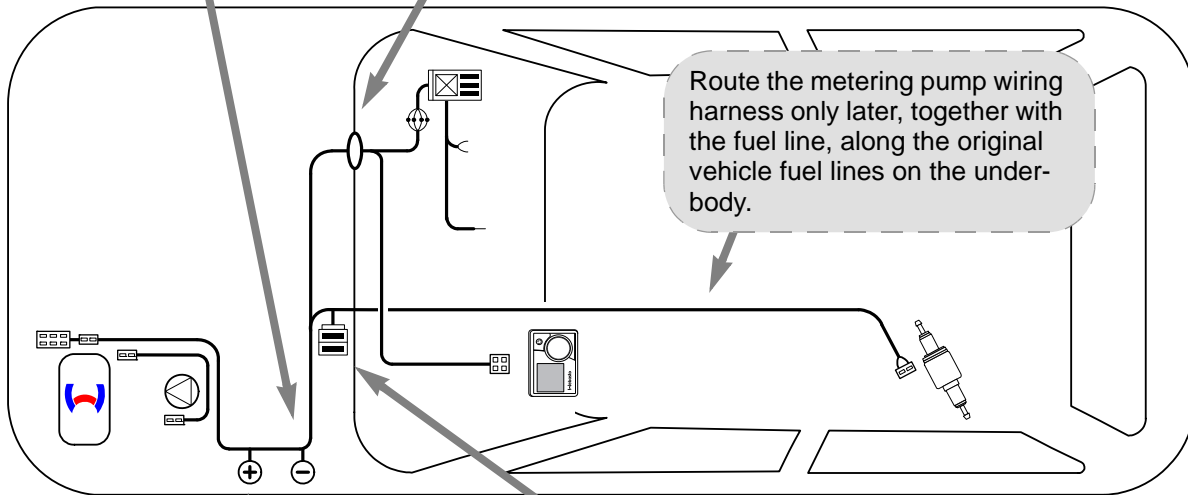
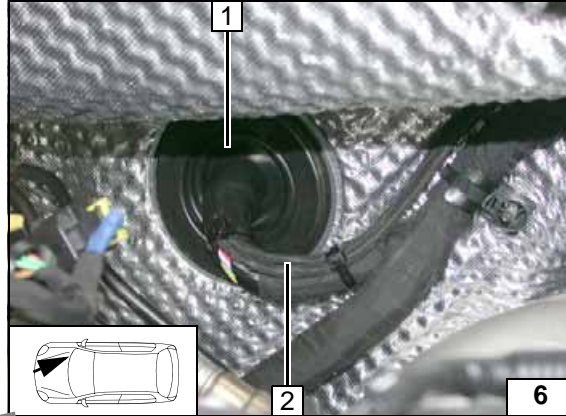

Wiring harness routing diagram

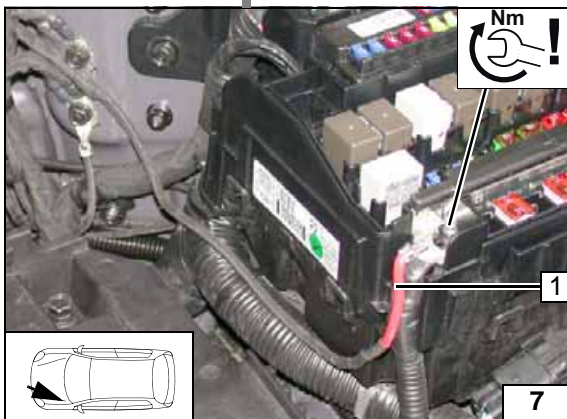

Positive wire

- 1 Positive wire on original vehicle positive support point

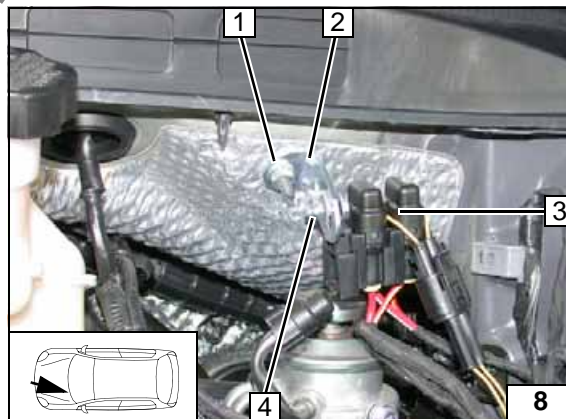

Engine compartment fuse holder

- 1 Original vehicle stud bolt, M6 flanged nut
- 2 Angle bracket
- 3 Fuses F1-2
- 4 M5x16 bolt, washer [2x], retaining plate of fuse holder, nut



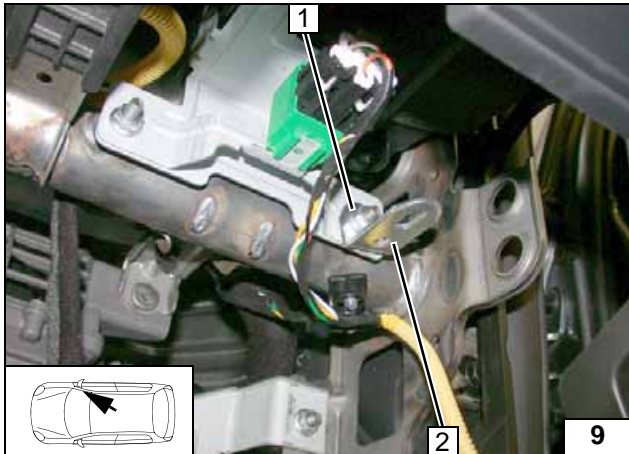

Installing Passenger Compartment Relay and Fuse Holder

- 1 Original vehicle bolt, original vehicle nut
- 2 Angle bracket

Installing angle bracket

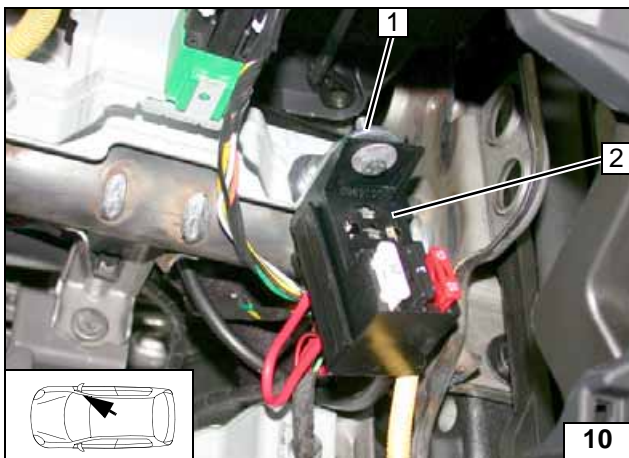

- 1 M5x16 bolt, large diameter washer [2x], nut
- 2 Passenger compartment relay and fuse holder

Installing passenger compartment relay and fuse holder

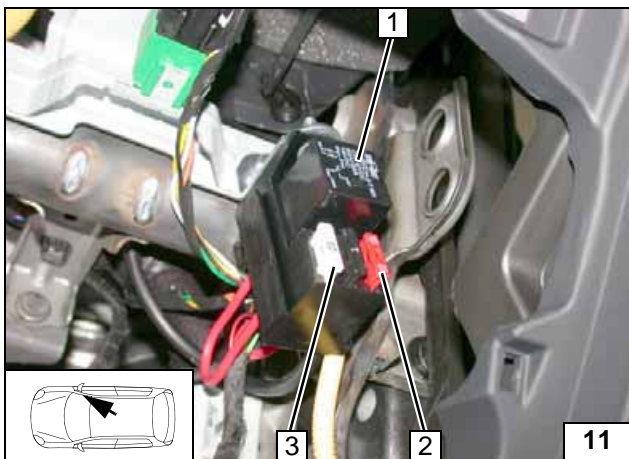

- 1 K1 relay
- 2 10A fuse F5
- 3 25A fuse F4

Installing K1 relay, fuses F4 and F5

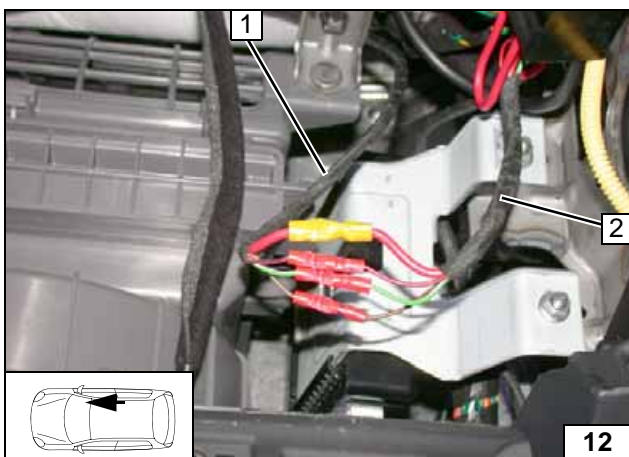

- 1 Wiring harness of heater
- 2 Wiring harness of passenger compartment relay and fuse holder

Connecting same colour wires of wiring harnesses



Fan Controller for Manual Air-Conditioning

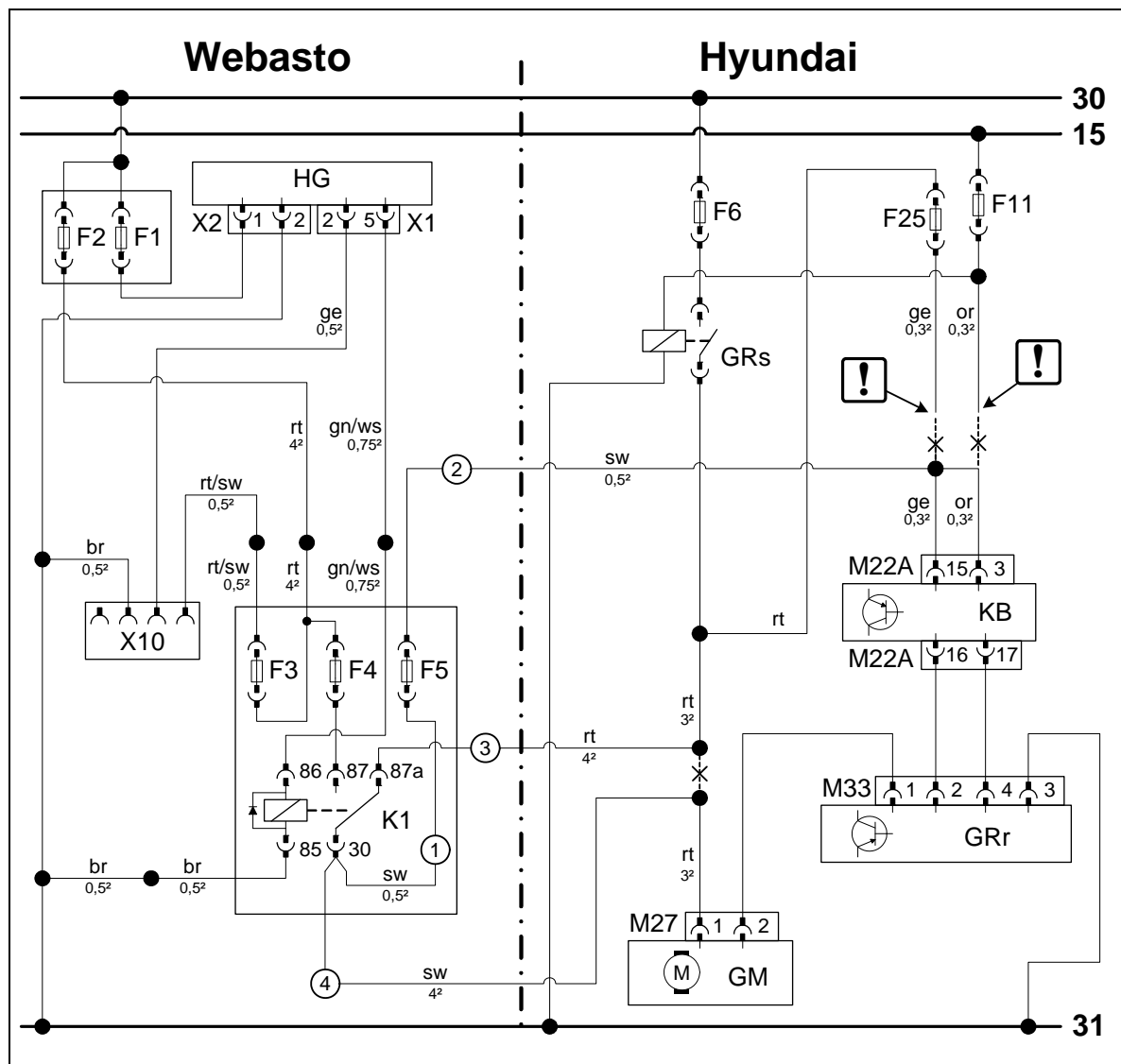

Wiring diagram

Webasto components		Vehicle components		Colours and symbols	
HG	TT-Evo heater	F11	7.5A fuse	rt	red
X1	6-pin heater connector	F6	40A fuse	sw	black
X2	2-pin heater connector	F25	10A fuse	ge	yellow
F1	20A fuse	GRs	Fan relay	gn	green
F2	30A fuse	KB	A/C control panel	or	orange
X10	4-pin connector of heater control	M22A	26-pin connector of KB	ws	white
F3	1A fuse	GRr	Fan controller	br	brown
F4	25A fuse	M33	4-pin connector of GRr		
F5	10A fuse	GM	Fan motor		
K1	Fan relay	M27	2-pin connector of GM		
					Insulate wire end and tie back
				X	Cutting point
					Wiring colours may vary.

Legend

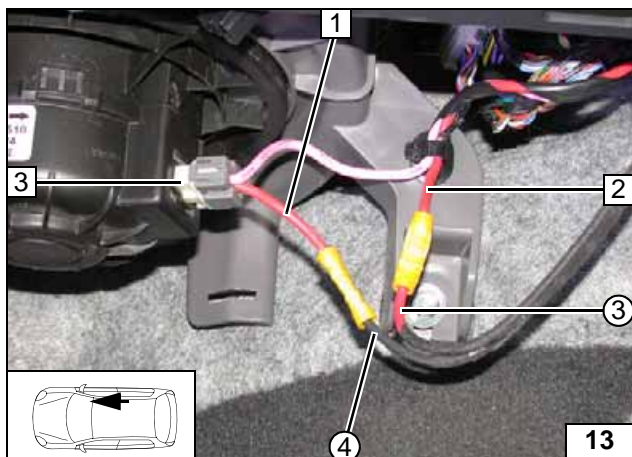

Connection to 2-pin connector 3 M27 from the fan motor.

- 1 Red (rt) wire of connector, GM M27
- 2 Red (rt) wire of fan relay
- ③ Red (rt) wire of K1/87a, fan wiring harness
- ④ Black (sw) wire of K1/30, fan wiring harness



**Connect-
ing fan mo-
tor**

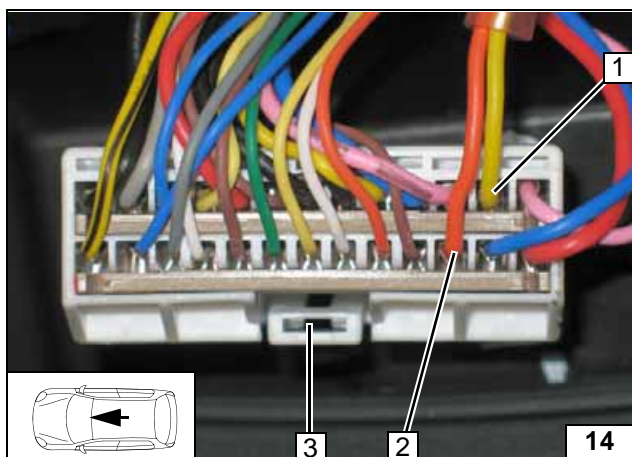

Connection to 26-pin connector 3 M22A from A/C control unit.

- 1 Yellow (ge) wire of 26-pin connector, pin 15
- 2 Orange (or) wire of 26-pin connector, pin 3



**Connect-
ing A/C
control unit**

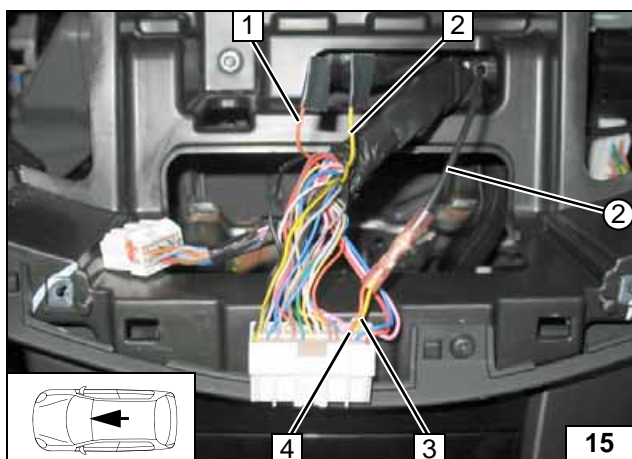

Insulate and tie back orange (or) 1 and yellow (ge) 2 wires.

- 3 Yellow (ge) wire of 26-pin connector, pin 15
- 4 Orange (or) wire of 26-pin connector, pin 3
- ② Black (sw) wire of fuse F5



**Connect-
ing A/C
control unit**

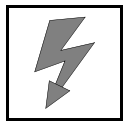

Fan Controller for Automatic Air-Conditioning

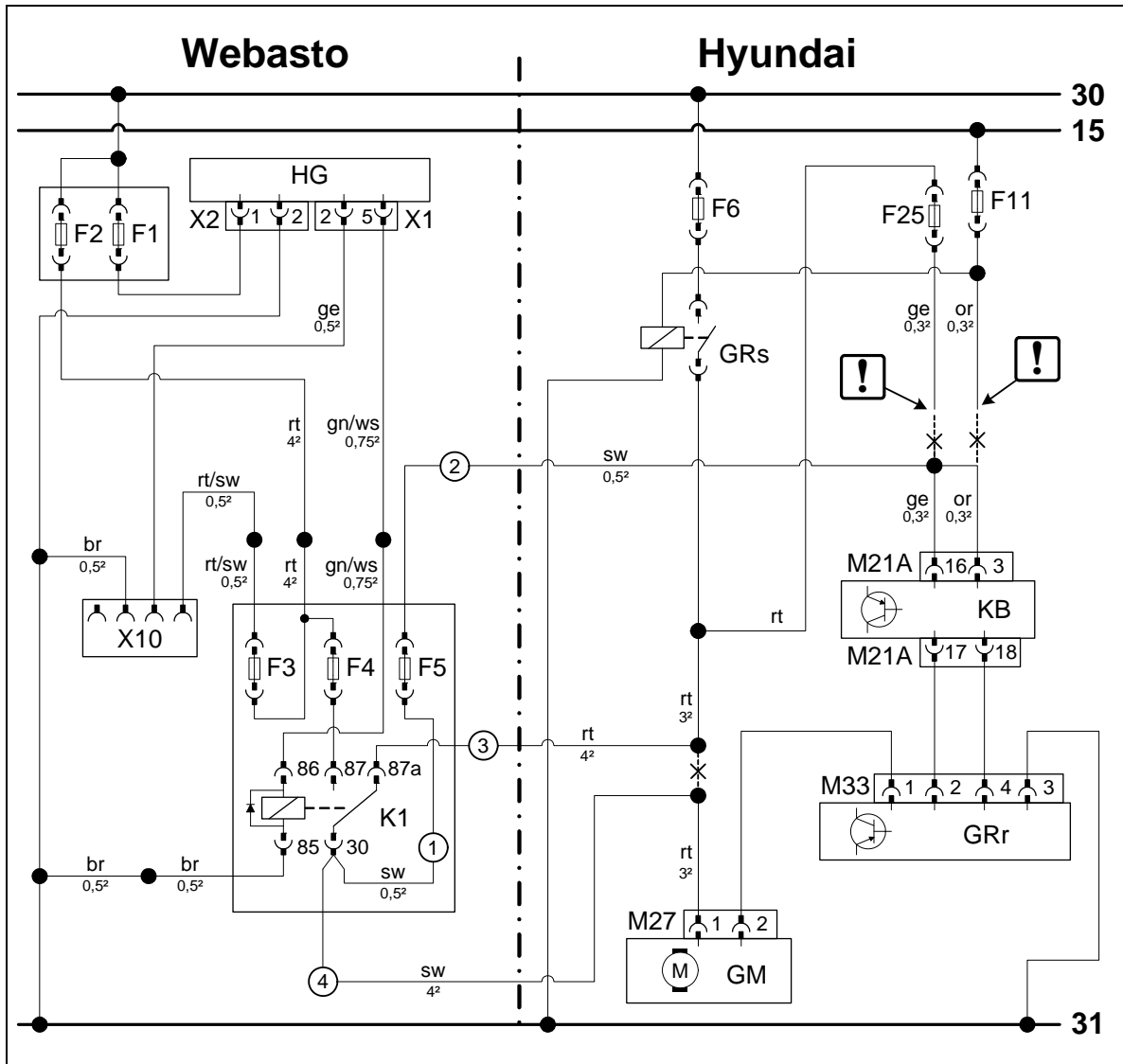

Wiring diagram

Webasto components		Vehicle components		Colours and symbols	
HG	TT-Evo heater	F11	7.5A fuse	rt	red
X1	6-pin heater connector	F8	40A fuse	sw	black
X2	2-pin heater connector	F25	10A fuse	ge	yellow
F1	20A fuse	GRs	Fan relay	gn	green
F2	30A fuse	KB	A/C control panel	or	orange
X10	4-pin connector of heater control	M21A	40-pin connector of KB	ws	white
F3	1A fuse	GRr	Fan controller	br	brown
F4	25A fuse	M33	4-pin connector of GRr		
F5	10A fuse	GM	Fan motor		
K1	Fan relay	M27	2-pin connector of GM		
					Insulate wire end and tie back
				X	Cutting point
Wiring colours may vary.					

Legend

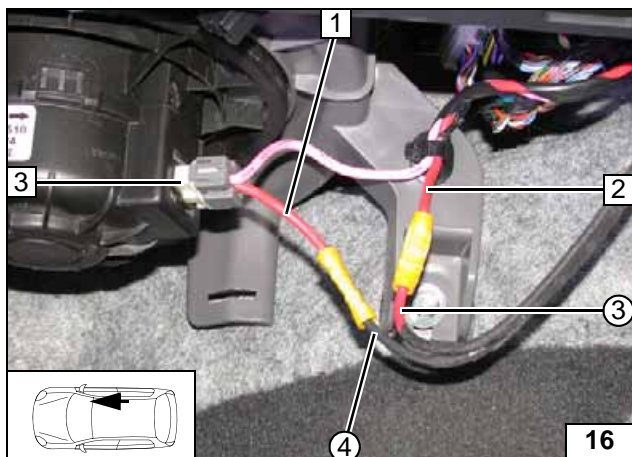
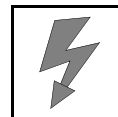

Connection to 2-pin connector 3 M27 from the fan motor.

- 1 Red (rt) wire of connector, GM M27
- 2 Red (rt) wire of fan relay
- ③ Red (rt) wire of K1/87a, fan wiring harness
- ④ Black (sw) wire of K1/30, fan wiring harness



**Connect-
ing fan mo-
tor**

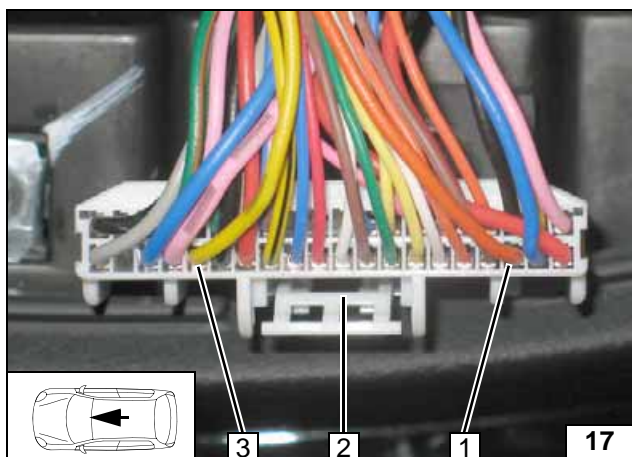

Connection to 40-pin connector 2 M21A from A/C control unit.

- 1 Orange (or) wire of 40-pin connector, pin 3
- 3 Yellow (ge) wire of 40-pin connector, pin 16



**Connect-
ing A/C
control unit**

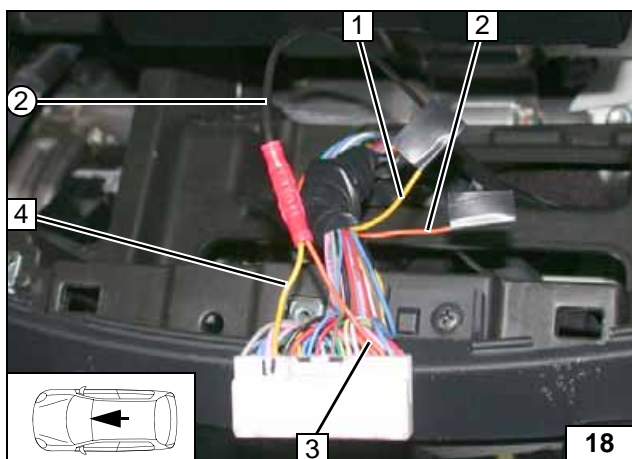

Insulate and tie back yellow (ge) 1 and orange (or) 2 wires.

- 3 Orange (or) wire of 40-pin connector, pin 3
- 4 Yellow (ge) wire of 40-pin connector, pin 16
- ② Black (sw) wire of fuse F5



**Connect-
ing A/C
control unit**

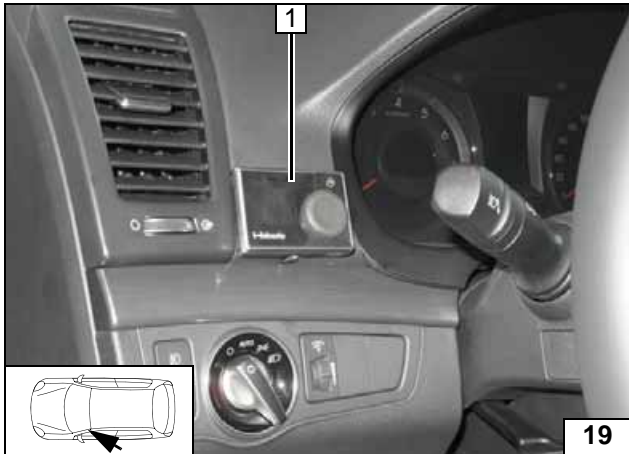

MultiControl CAR Option

- 1 MultiControl CAR



Installing
MultiControl
CAR

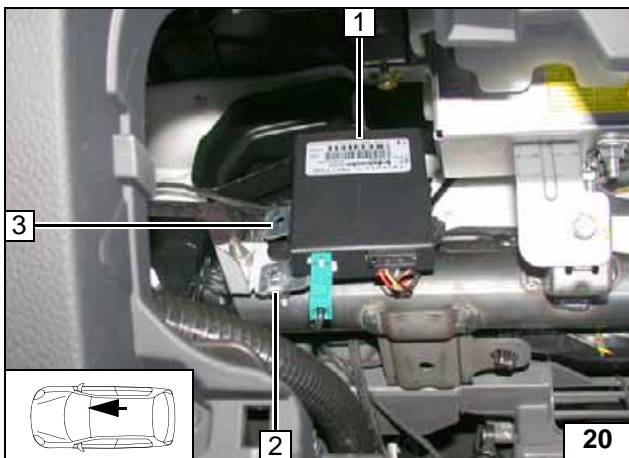

Remote Option (Telestart)

- 1 Receiver
- 2 M6x12 bolt, flanged nut, existing hole
- 3 Align bracket



Installing
receiver

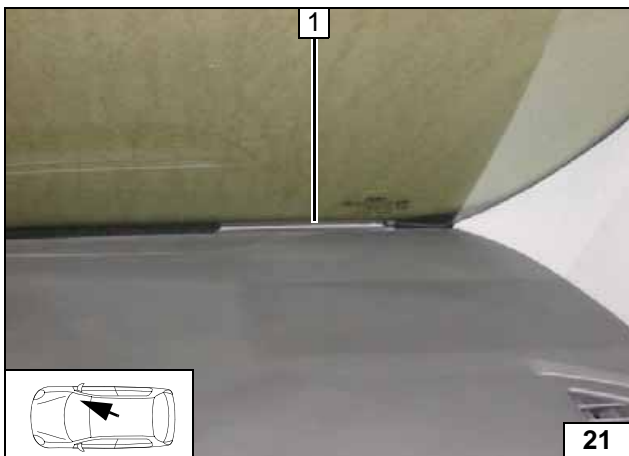

- 1 Aerial

Installing
aerial

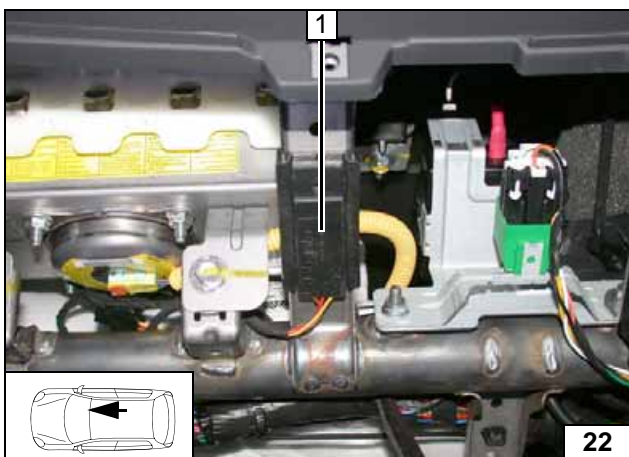

Temperature sensor T100 HTM

Fasten temperature sensor 1 with adhesive tape.



Installing
tempera-
ture sensor

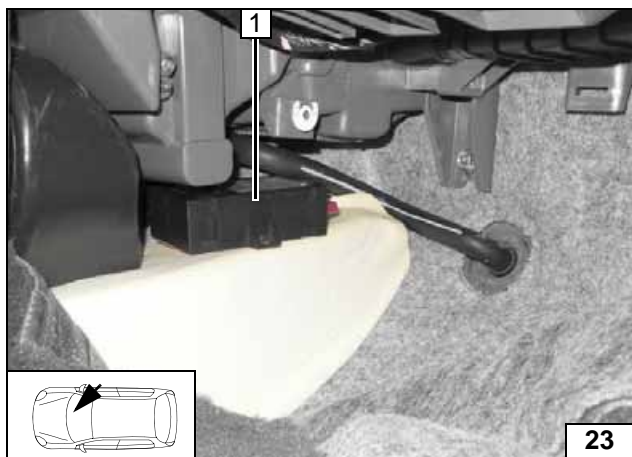

Thermo Call Option

Fold back the floor covering for the installation. Fasten receiver 1 with adhesive tape.

Installing receiver

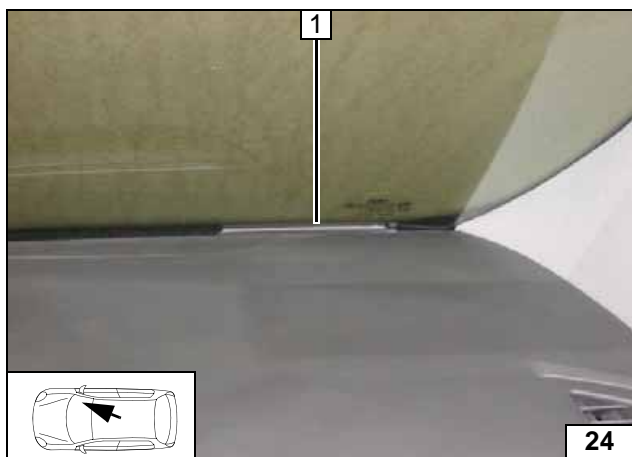

1 Aerial

Installing aerial

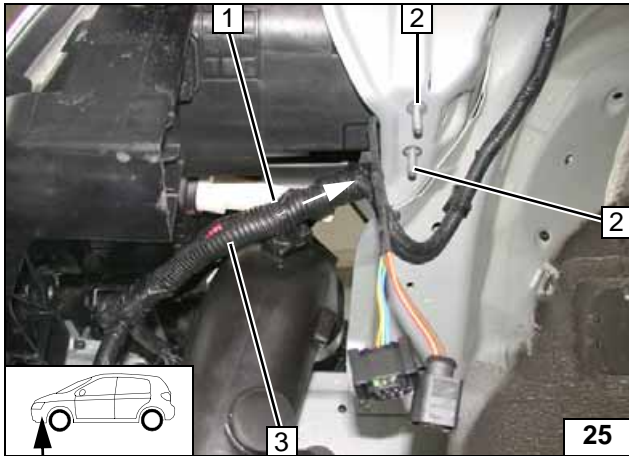

Preparing Installation Location

Detach cable tie **1**, push original vehicle wiring harness **3** back by 20mm and close cable tie **1** again.

- 2** M6x20 bolt, pin lock [2x]



Inserting bolts



- 1** 100 mm edge protection

Installing edge protection

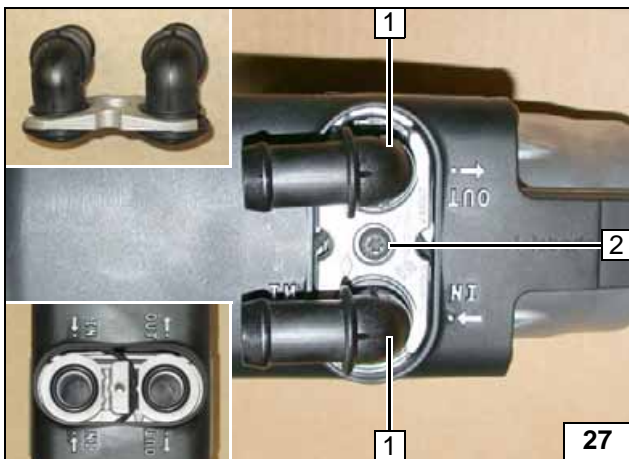

Preparing Heater

- 1** Water connection piece, sealing ring [2x]
- 2** 5x15 self-tapping bolt, retaining plate of water connection piece



Installing water connection piece

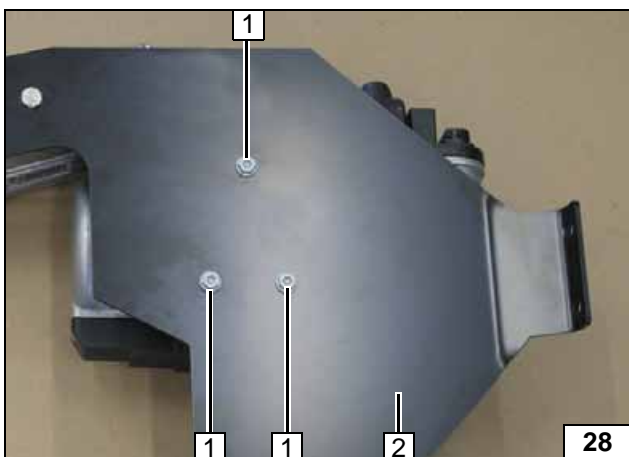

- 1** 5x13 self-tapping bolt [3x]
- 2** Bracket

Installing bracket

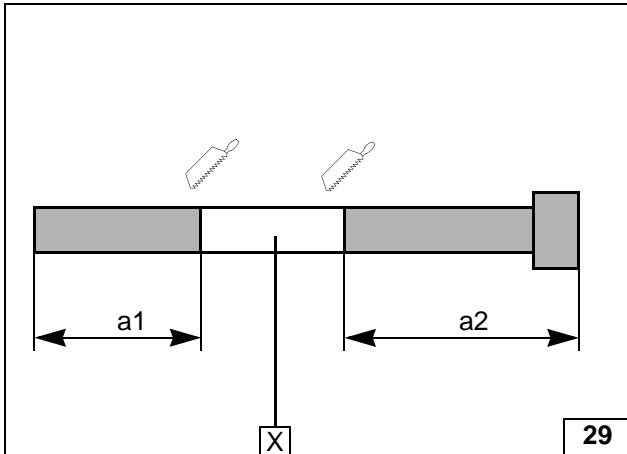

	with Xenon	without Xenon
$a1 =$	85	100
$a2 =$	270	270



Preparing exhaust pipe

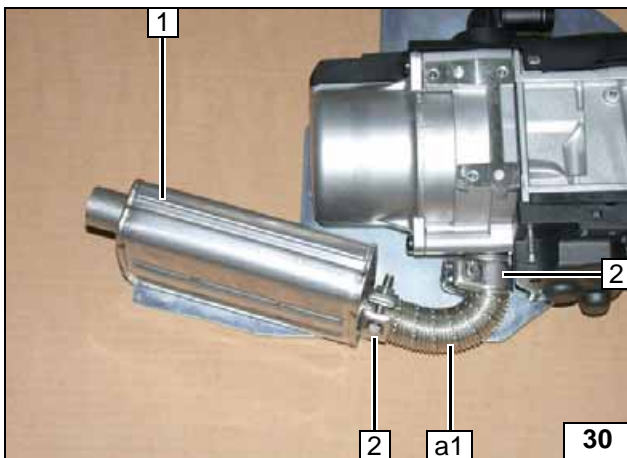
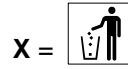

- 1 Silencer
- 2 Hose clamp [2x]

Installing exhaust pipe a1 and silencer

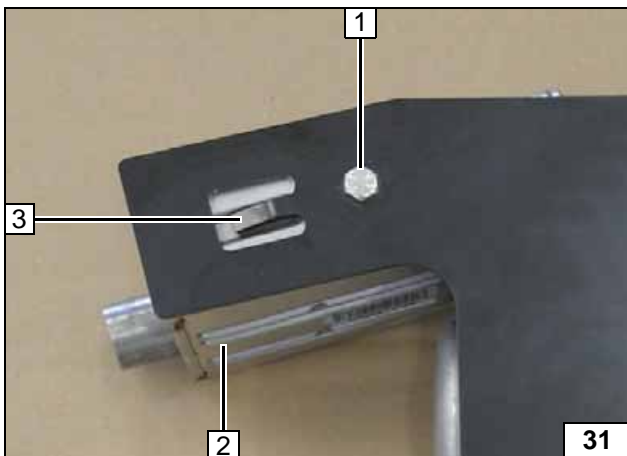

Align locking tab 3 with recess (twist protection)!

- 1 M6x20 bolt, spring lockwasher
- 2 Silencer



Installing silencer

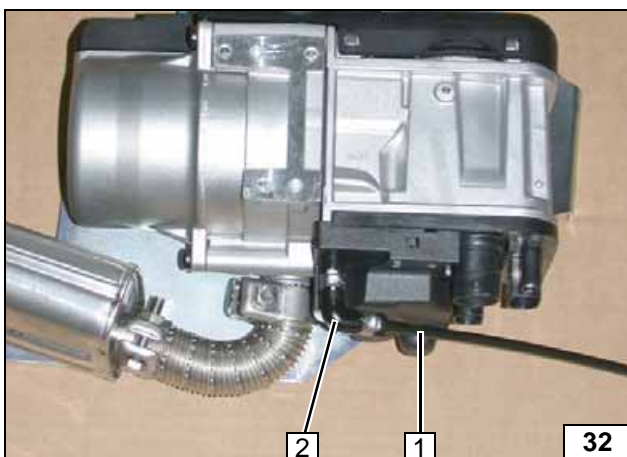

- 1 Fuel line
- 2 90° moulded hose, 10mm dia. clamp [2x]

Installing fuel line

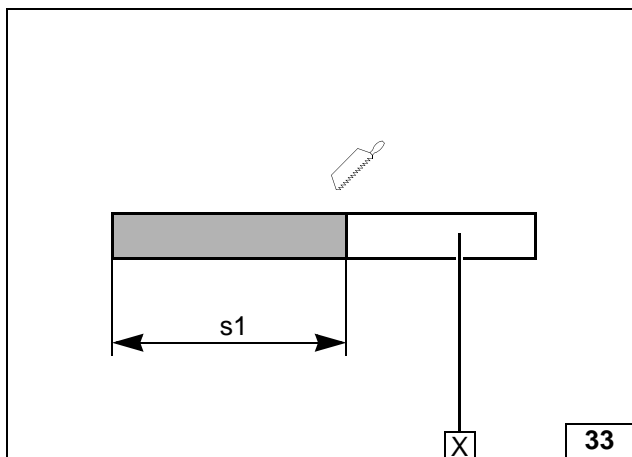

s1 = 290

X =



Cutting combustion air pipe to length

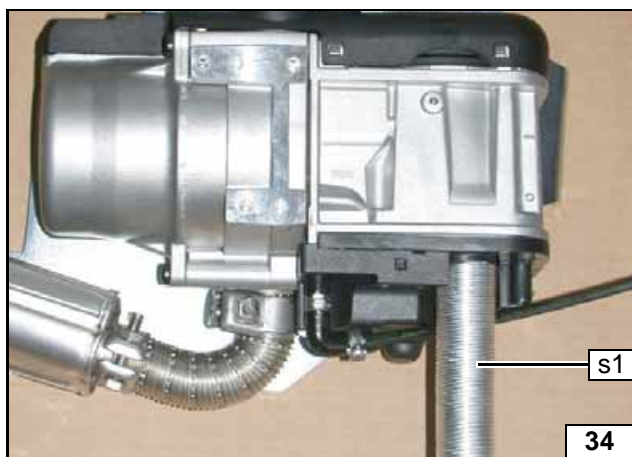

1 Combustion air pipe



Installing combustion air pipe s1

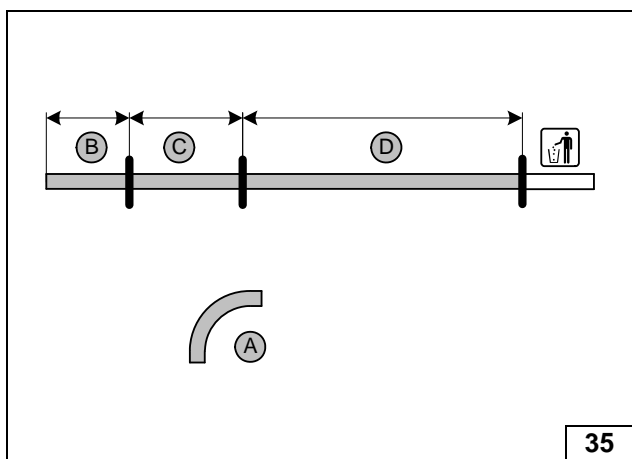

Hose A = 18x 20 mm dia., 90° moulded hose

	with Xenon	without Xenon
B =	115	115
C =	595	580
D =	975	960



Cutting hoses to length

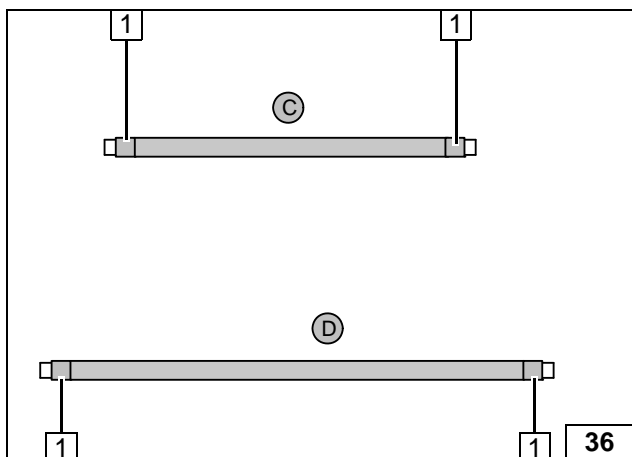

Push braided protection hoses onto hoses C and D and cut to length. Cut heat shrink plastic tubing to size.

1 25 mm long heat shrink plastic tubing [4x]



Preparing hoses

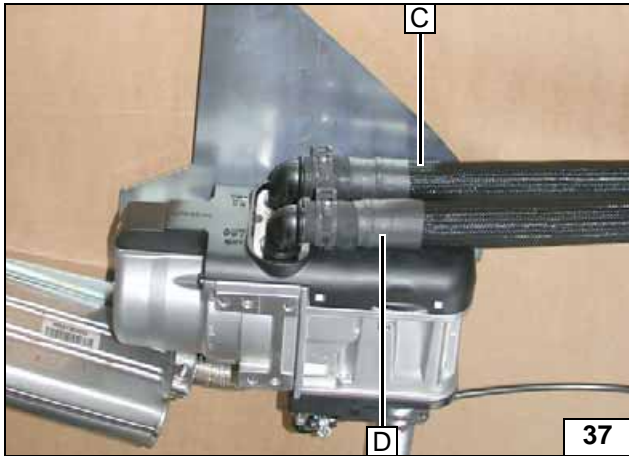

All spring clips = 25 mm dia.



Premounting hoses

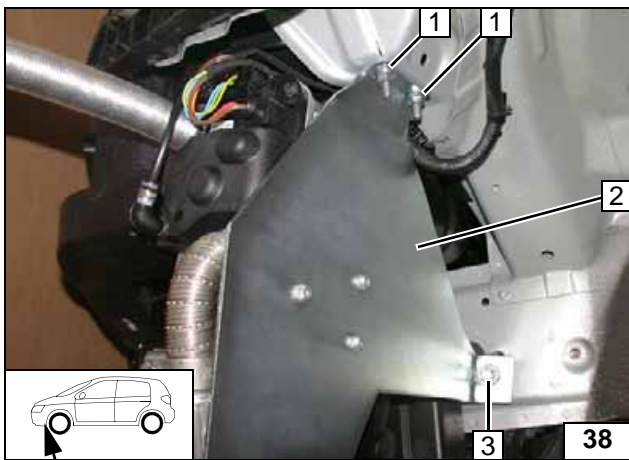

Installing Heater

Remove original vehicle bolt at position 3. Fasten bracket 2 with M6x35 bolt, large diameter washer and resonator to original vehicle threaded hole at position 3.



Installing heater

- 1 Flanged nut [2x]
- 3 M6x35 bolt, large diameter washer

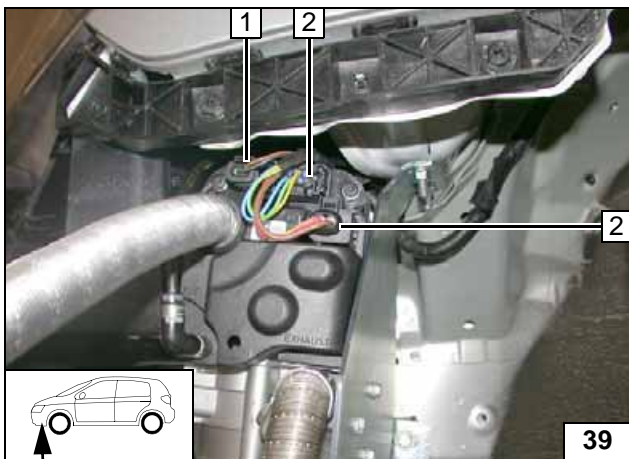

- 1 Wiring harness of circulating pump
- 2 Wiring harness of heater [2x]

Installing wiring harnesses



- 1 5x13 self-tapping bolt [2x]
- 2 Strut
- 3 M6x25 bolt

Installing strut

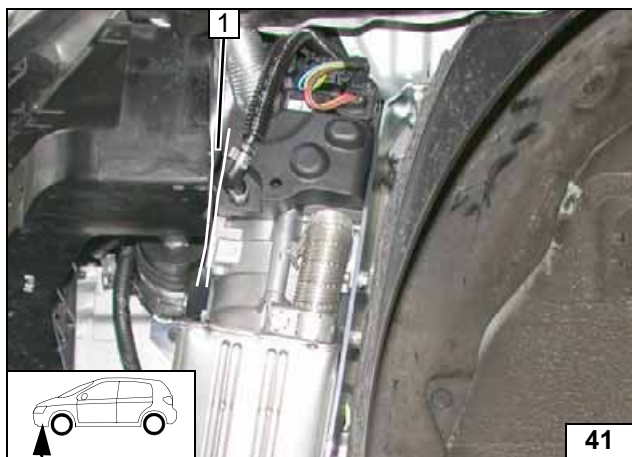
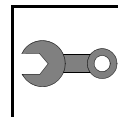

Ensure sufficient distance between heater and vehicle at position 1, correct if necessary.



Aligning heater

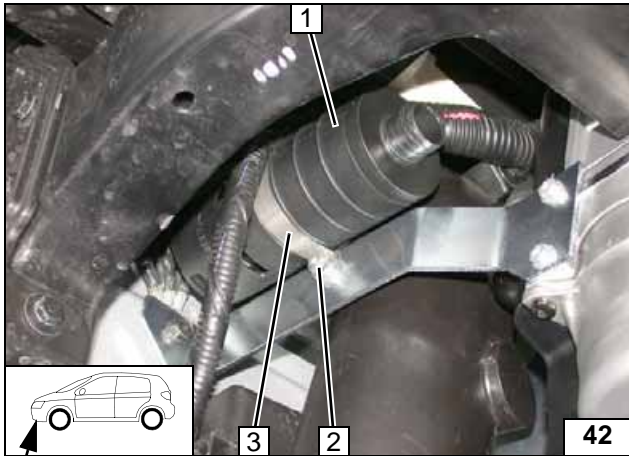
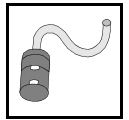

Combustion Air

- 1 Loosely mount silencer
- 2 M5x16 bolt, flanged nut
- 3 51mm dia. clamp



**Installing
silencer
loosely**



Align silencer 1. Tighten M5x16 bolt.



**Installing
combustion
air pipe
s1**



Coolant Circuit



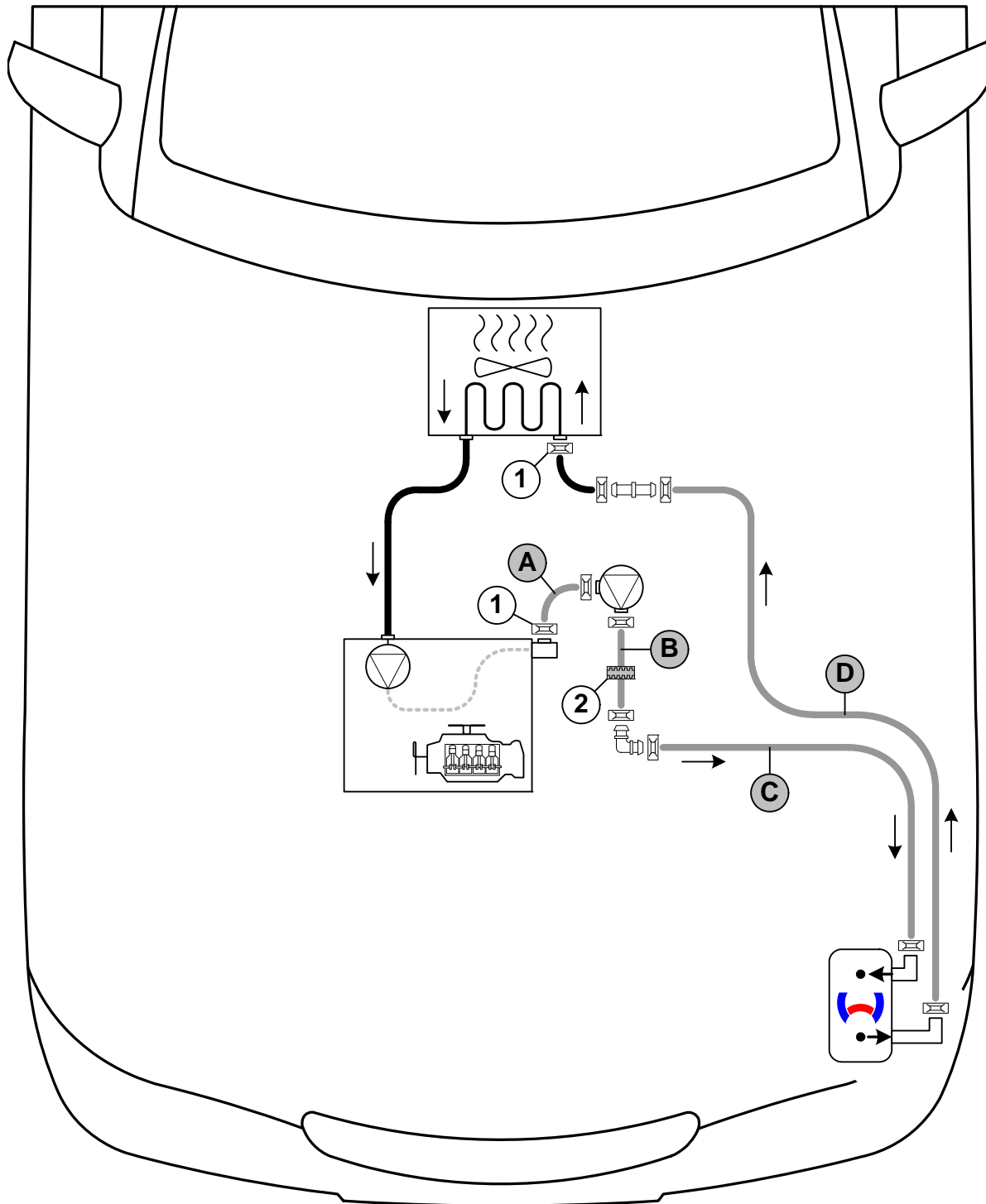

WARNING!

Any coolant running off should be collected in an appropriate container. Route hoses kink-free. Unless specified otherwise, always fasten using cable ties. Position clamps so that other hoses cannot be damaged. The heater must be filled with coolant when installing the hoses.

The connection should be modelled on an 'inline' circuit and based on the following diagram:



Hose routing diagram

All spring clips without a specific designation  = 25 mm dia.
1 = Original vehicle spring clip . **2** = Black (sw) rubber isolator .
 All connecting pipes  and  = 18x18 mm dia.



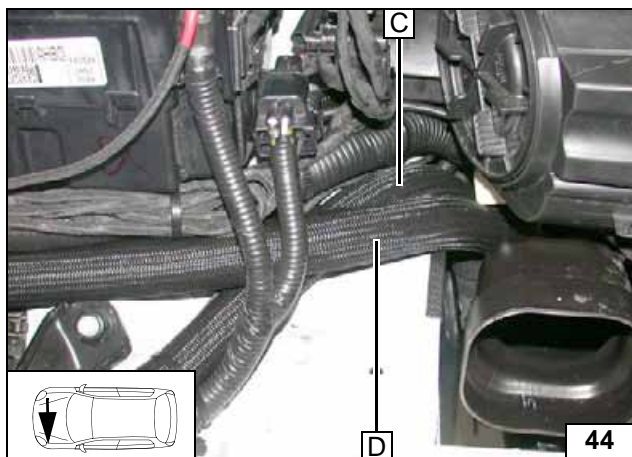

Routing in engine compartment

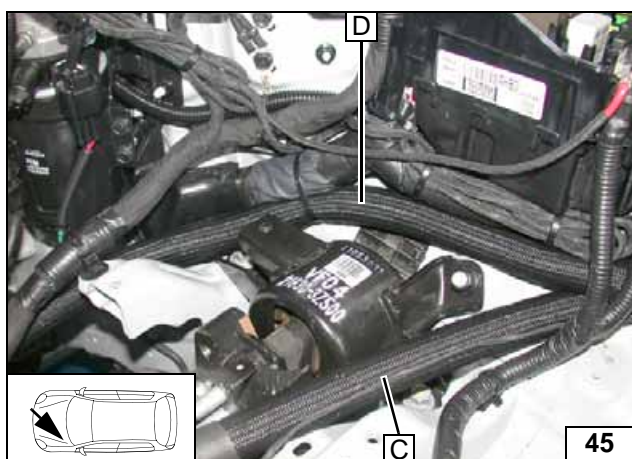

Routing in engine compartment

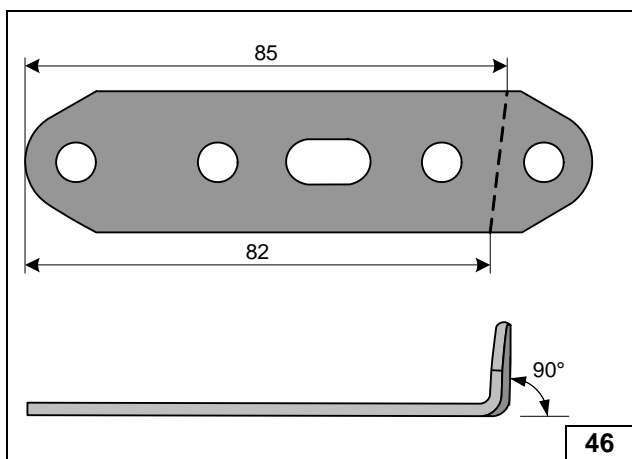

Angling down perforated bracket

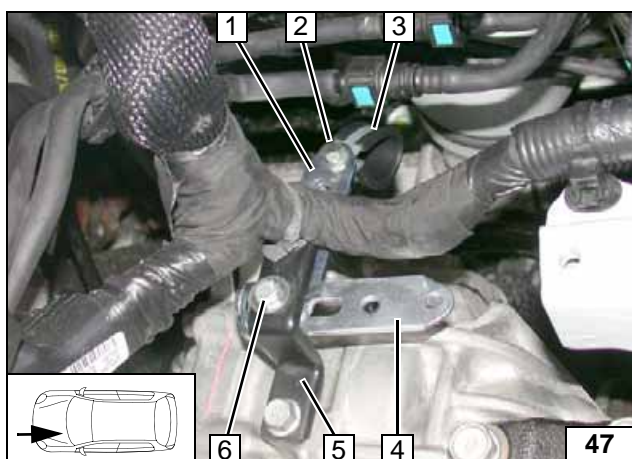

Insert 10mm shim between original vehicle bracket 5 and prepared perforated bracket 4.



- 1 Perforated bracket
- 2 M6x20 bolt, flanged nut
- 3 Install 25 mm dia. rubber-coated p-clamp
- 6 M6x30 bolt, large diameter washer, 10mm shim, flanged nut

Installing perforated brackets

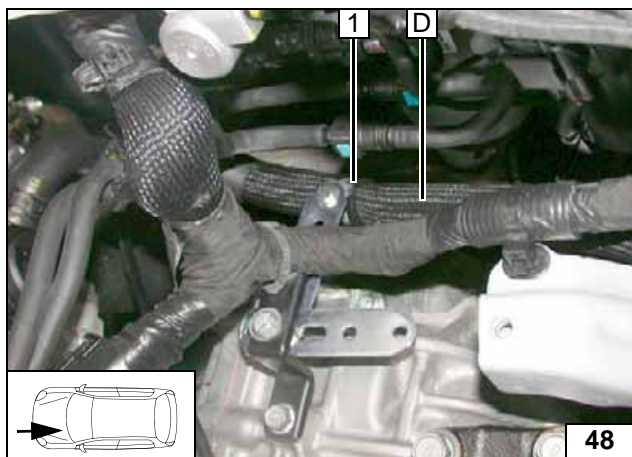

Route hose **D** through rubber-coated p-clamp **1**.



Routing in engine compartment

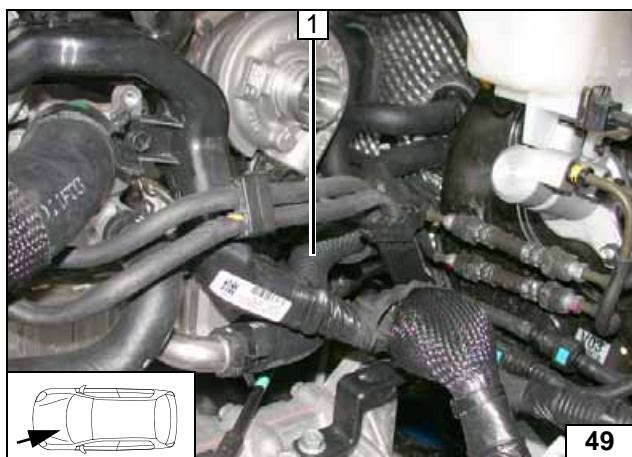

Remove hose **1** from engine outlet/heat exchanger inlet. Spring clips will be re-used.



Cutting point

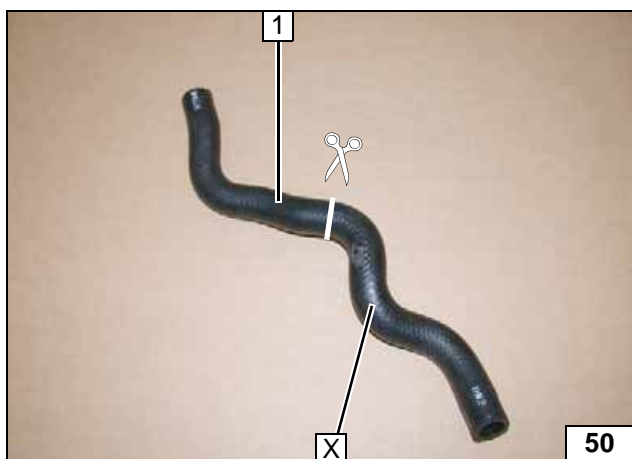

Remount hose section of heat exchanger inlet **1**.



1 Hose section of heat exchanger inlet

X =

Cutting point

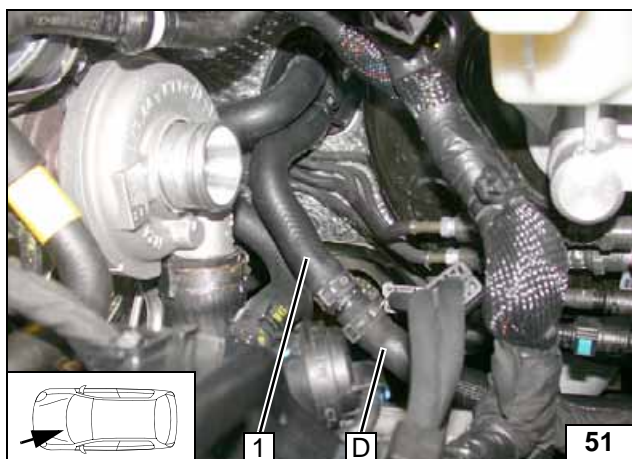

Install hose section of heat exchanger inlet **1** with original vehicle spring clip.



Connecting heat exchanger inlet

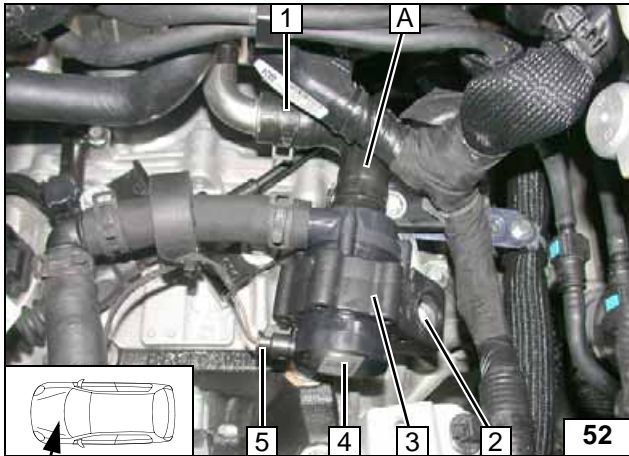

- 1 Original vehicle spring clip
- 2 M6x25 bolt, perforated bracket, flanged nut
- 3 Circulating pump mount
- 4 Circulating pump
- 5 Mount wiring harness of circulating pump

Installing circulating pump, connection of engine outlet

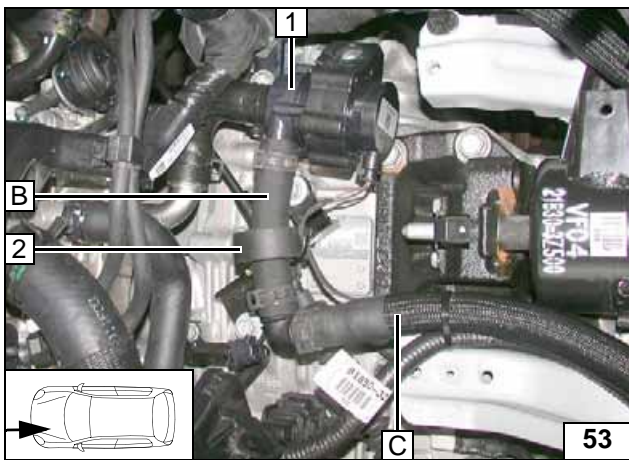

Slide black (sw) rubber isolator **2** onto hose **B** and align.

- 1 Circulating pump



Connecting hoses B and C

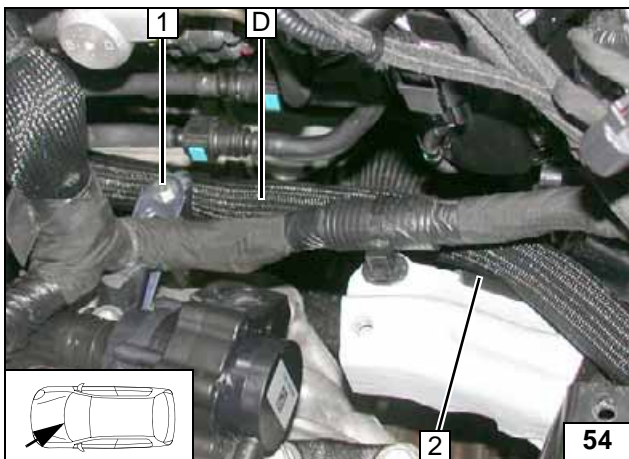

Align hoses. Ensure sufficient distance from neighbouring components, correct if necessary.

- 1 Tighten M6x20 bolt
- 2 100 mm edge protection



Installing edge protection



Fuel

CAUTION!

Open the vehicle's fuel tank cap, ventilate the tank and then re-close the tank lock.

Catch any fuel running off in an appropriate container.

Route fuel line and metering pump wiring harness so that they are protected against stone impact. Unless specified otherwise, always fasten using cable ties.

Provide rub protection for fuel line and wiring harness in areas where there are sharp edges.

WARNING!

The fuel line and wiring harness are routed to the metering pump as shown in the wiring harness routing diagram.



Route fuel line and wiring harness of metering pump in 10 mm dia. corrugated tube 1 in engine compartment.

Routing lines

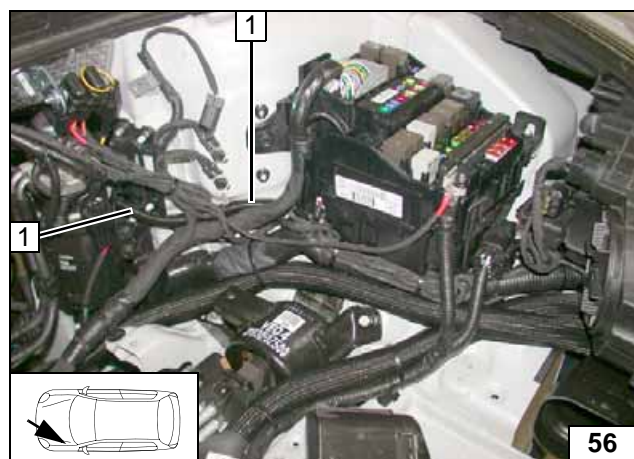

Route fuel line and wiring harness of metering pump in 10mm dia. corrugated tube 1 to the firewall.

Routing lines

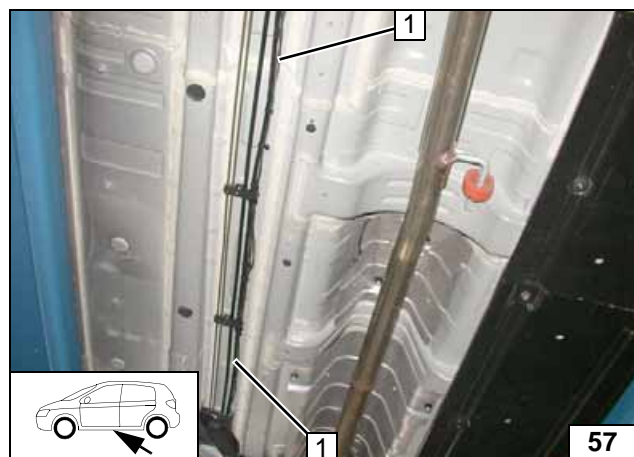

1 Fuel line and wiring harness of metering pump

Routing lines

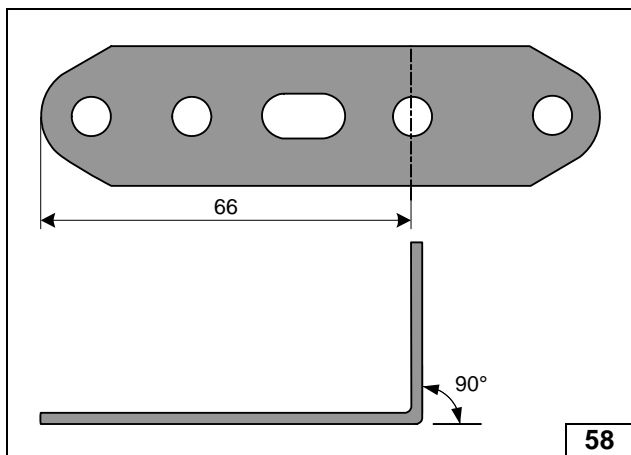
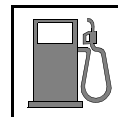

Cutting perforated bracket to length

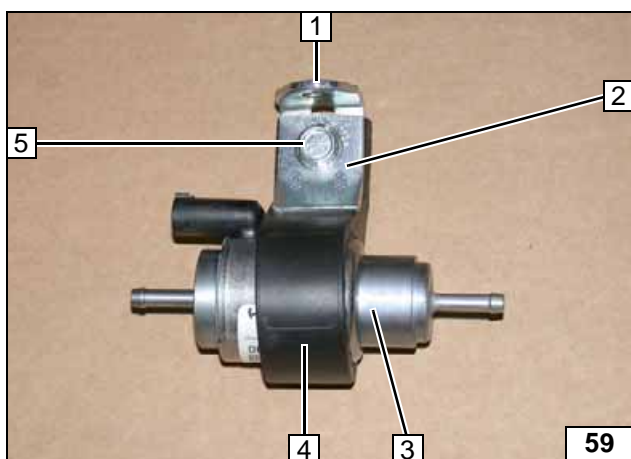

- 1 Perforated bracket
- 2 Support angle bracket
- 3 Metering pump
- 4 Metering pump mount
- 5 M6x25 bolt, flanged nut

Premounting metering pump

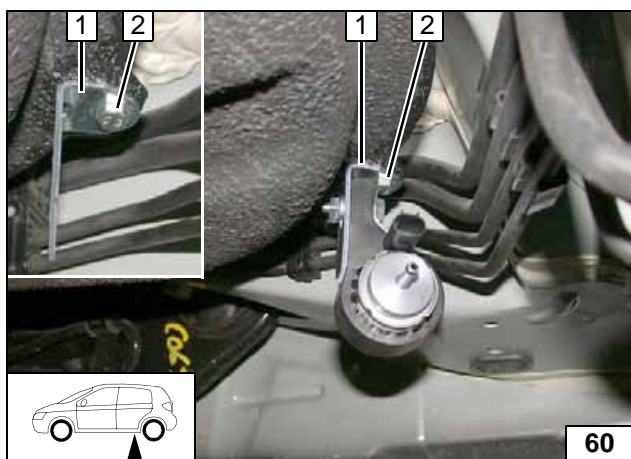

- 1 Perforated bracket
- 2 M6x20 bolt, flanged nut, existing hole



Installing metering pump

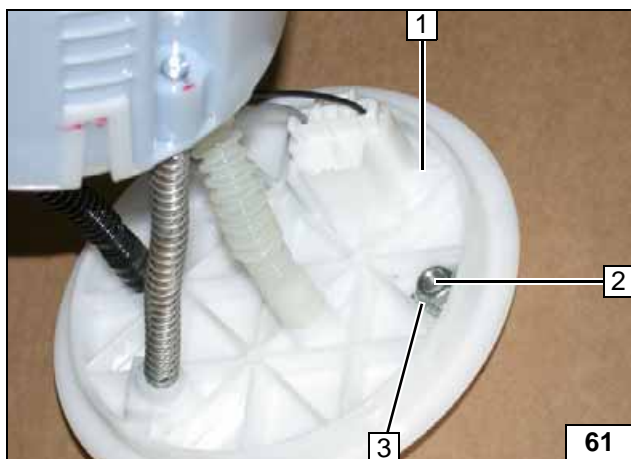

Remove fuel tank sending unit 1 in accordance with the manufacturer's instructions. Position M6 flanged nut 3 between the ribs.

- 2 Copy hole pattern, 6mm dia. hole



Fuel extraction

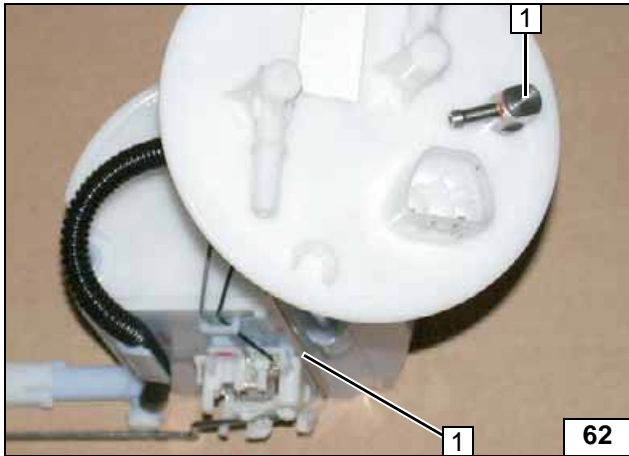

Bend fuel standpipe **1** according to template and cut to length.



Installing fuel stand-pipe

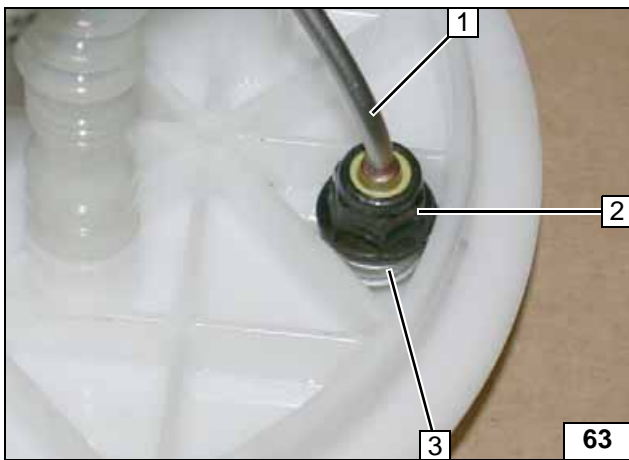

Insert three washers as height compensation at position **3**.



Installing fuel stand-pipe

- 1** Fuel standpipe
- 2** Tighten flanged nut

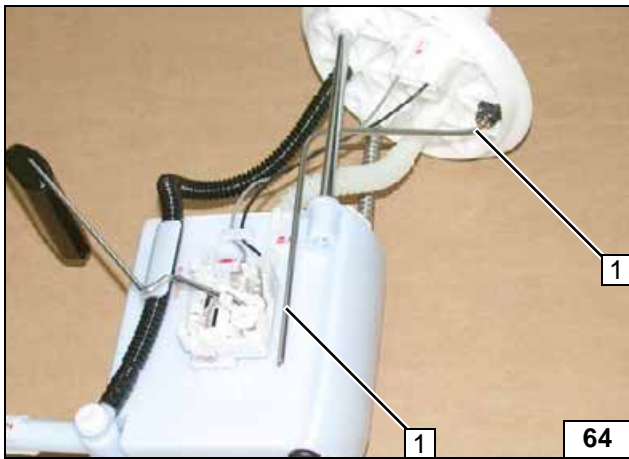

1 Align fuel standpipe



Installing fuel stand-pipe

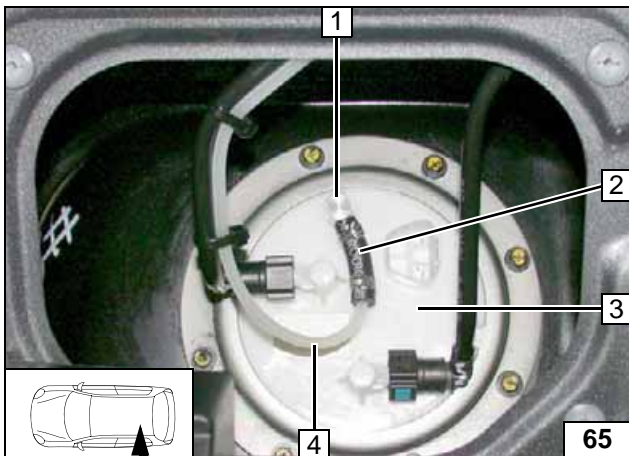

Install fuel tank sending unit **3** in accordance with manufacturer's instructions.



- 1** Fuel standpipe
- 2** Moulded hose, 10 mm dia. clamp [2x]
- 4** Fuel line

Connecting fuel line

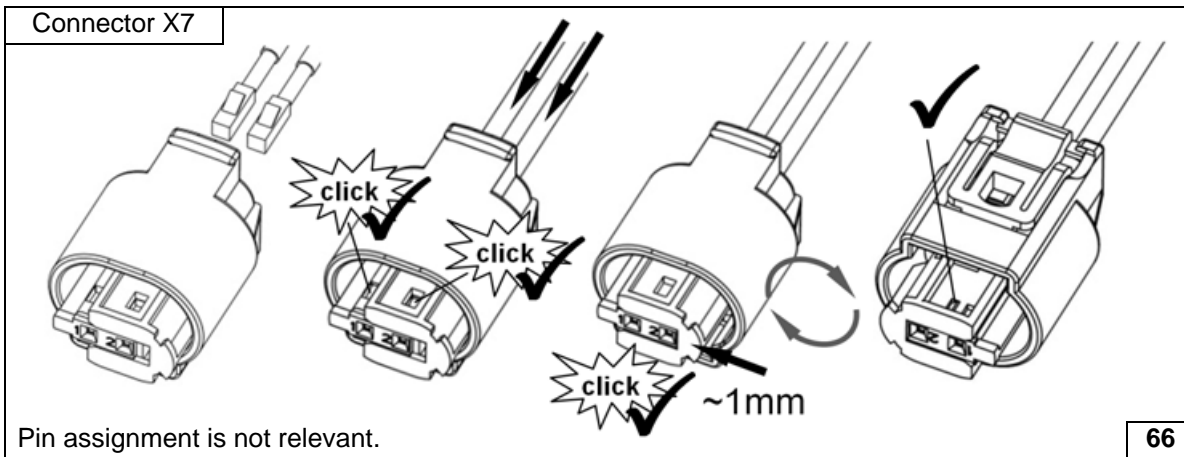
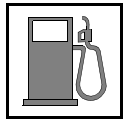

Completing metering pump connector

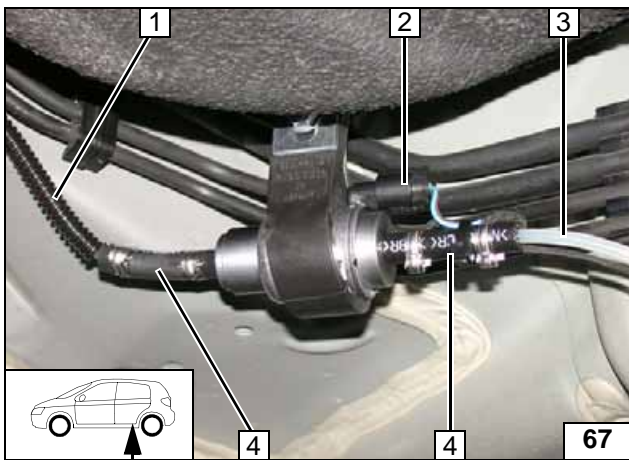

Slide 10mm dia. corrugated tube 1 on to fuel line of fuel standpipe. Check the position of the components; adjust if necessary. Check that they have freedom of movement.



- 2 Wiring harness of metering pump, connector X7 mounted
- 3 Fuel line of heater
- 4 Hose section [2x], 10mm dia. clamp [4x]

Connecting metering pump

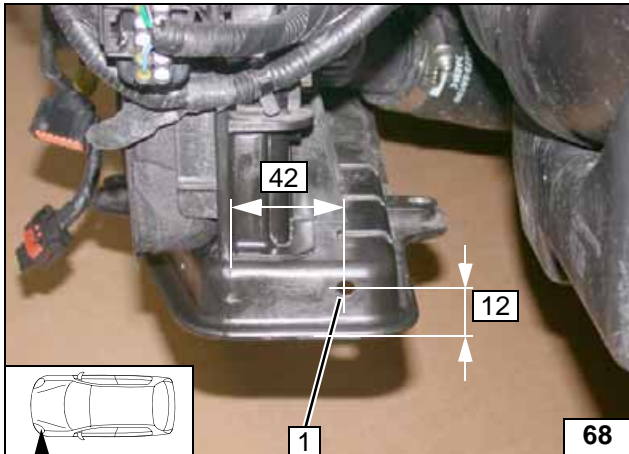
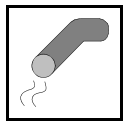

Exhaust Gas

- 1 7 mm dia. hole

Hole in cross member

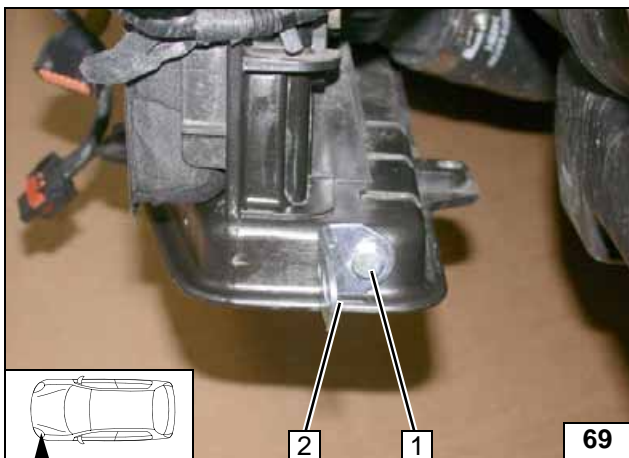

- 1 M6x20 bolt, flanged nut
- 2 Angle bracket

Installing angle bracket

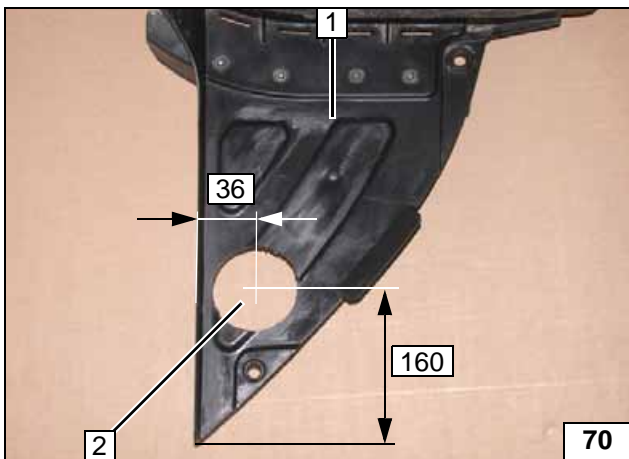

- 1 Wheel well trim on left-hand side
- 2 60 mm dia. hole

Cutting out left-hand wheel well trim

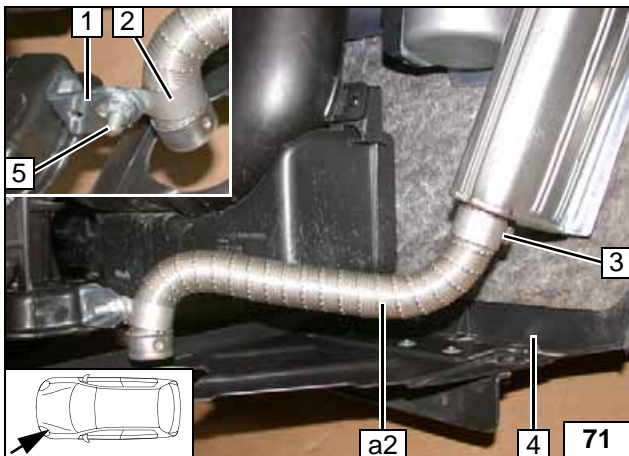

- 1 Angle bracket
- 2 25 mm dia. p-clamp
- 3 Hose clamp
- 4 Wheel well trim on the left-hand side, mounted
- 5 M6x20 bolt, flanged nut

Installing exhaust pipe a2

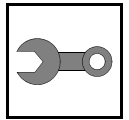

Final Work

WARNING!

Reassemble the components in reverse order. Check all hoses, clamps and all electrical connections for firm seating. Insulate and tie back all loose lines.

Only use manufacturer-approved coolant. Spray the heater components with anti-corrosion wax (Tectyl 100K, Order No. 111329).

- **Connect the battery.**
- **Fill and bleed the coolant circuit according to the vehicle manufacturer's specifications.**
- **Program MultiControl CAR, teach Telestart transmitter.**
- **Make settings on A/C control panel according to the 'Operating Instructions for End Customer'.**
- **Place the 'Switch off parking heater before refuelling' caution label near the filler neck.**
- **For initial startup and function check, please see installation instructions.**

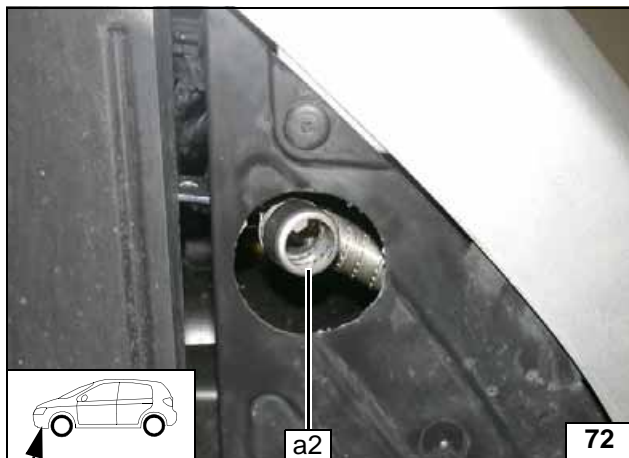

Align exhaust pipe **a2** with the centre of the hole.



**Aligning
exhaust
pipe a2**

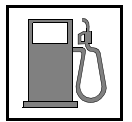

Template for Fuel Standpipe

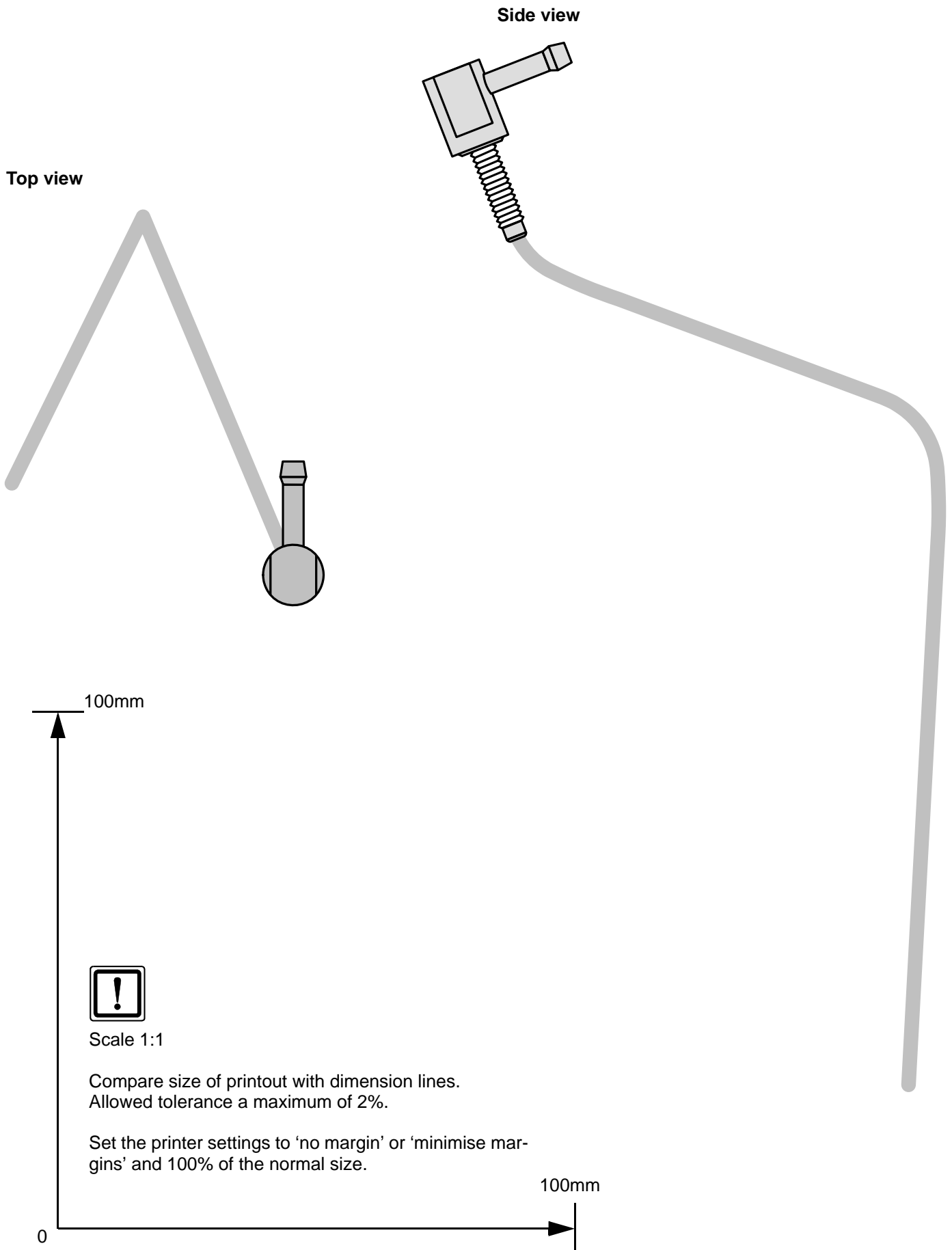

Operating Instructions for Manual Air-Conditioning

Please remove page and add to the vehicle operating instructions.

Note:

We recommend matching the heating time to the driving time.

Heating time = driving time

Example:

For a driving time of approx. 20 min. (in one direction), we recommend not exceeding a switch-on time of 20 min.

Passenger compartment monitoring, if installed, must be deactivated in addition to the vehicle settings for the heating operation.

For instructions on deactivation, please refer to the operating instructions of the vehicle.

Before parking the vehicle, make the following settings:



- 1 Set fan to level '2', or max. '3'
- 2 Air outlet to windscreen/ footwell.
- 3 Set temperature to 'max.'

A/C control panel

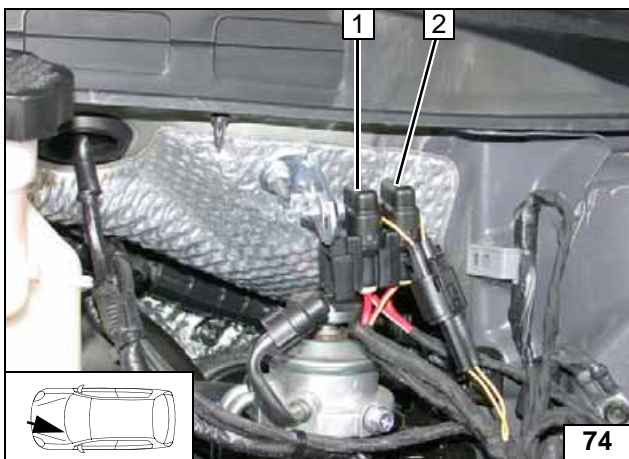

- 1 30A main fuse F2 of passenger compartment
- 2 20A heater fuse F1

Engine compartment fuses

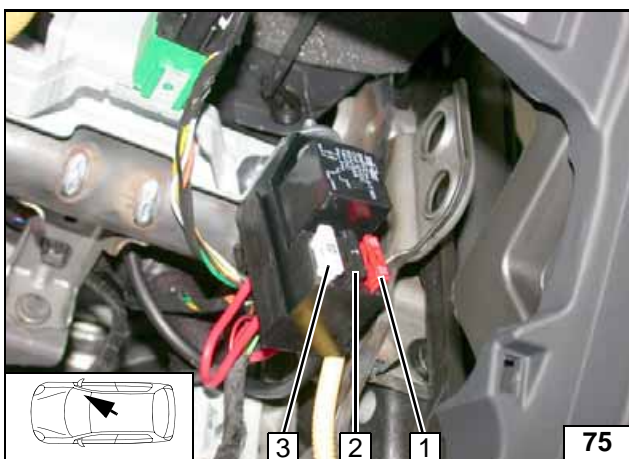

- 1 10A additional fuse F5
- 2 1A fuse F3 of heater control
- 3 25A fan fuse F4

Passenger compartment fuses



Operating Instructions for Automatic Air-Conditioning

Please remove page and add to the vehicle operating instructions.

Note:

We recommend matching the heating time to the driving time.

Heating time = driving time

Example:

For a driving time of approx. 20 min. (in one direction), we recommend not exceeding a switch-on time of 20 min.

Passenger compartment monitoring, if installed, must be deactivated in addition to the vehicle settings for the heating operation.

For instructions on deactivation, please refer to the operating instructions of the vehicle.

Before parking the vehicle, make the following settings:

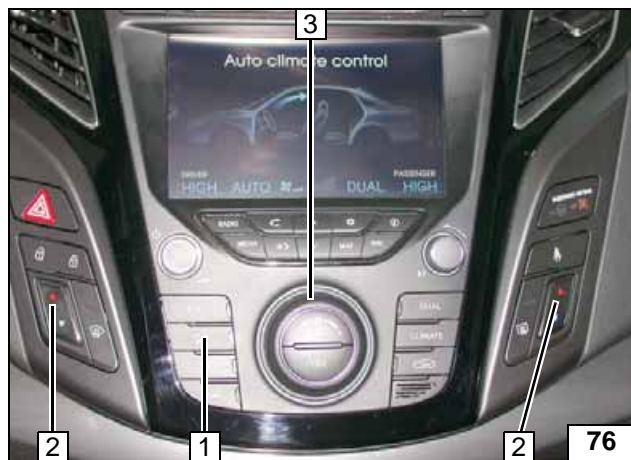

- 1 Air outlet faces 'upward'
- 2 Set temperature on both sides to 'HI'
- 3 Set fan to level '1', or max. '2'

A/C control panel

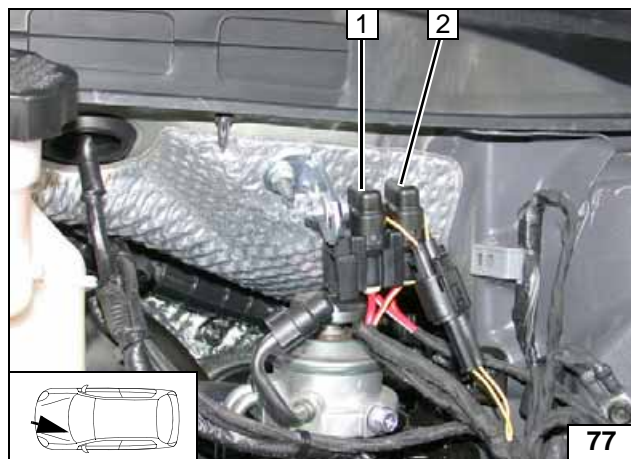

- 1 30A main fuse F2 of passenger compartment
- 2 20A heater fuse F1

Engine compartment fuses

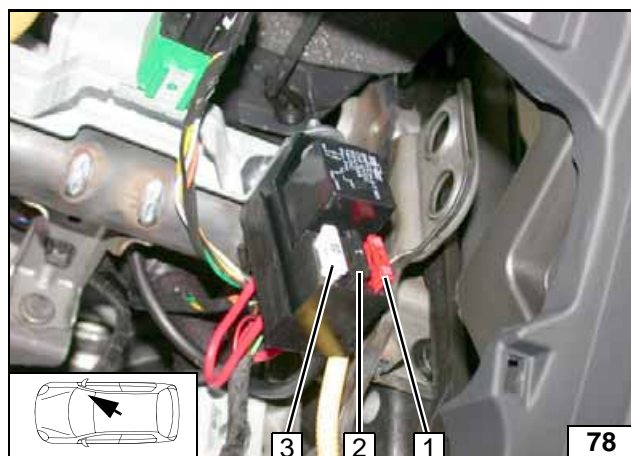

- 1 10A additional fuse F5
- 2 1A fuse F3 of heater control
- 3 25A fan fuse F4

Passenger compartment fuses

