

Water Heater

Thermo Top Evo Parking Heater



Installation Documentation

Citroen Jumper / Fiat Ducato / Peugeot Boxer

Validity

Fiat

Manufacturer	Model	Type	EG-BE No. / ABE
Fiat	Ducato	Multijet	e3 * 2007 / 46 * 0044 * ...
Fiat	Ducato	250 L	L779

Motorisation	Fuel	Transmission type	Output in kW	Displacement in cm ³	Engine code
2.0 D	Diesel	SG	85	1956	4HV
2.3 D	Diesel	SG	96	2287	F1AE3481D
2.3 D	Diesel	SG	109	2287	F1AE3481E
3.0 D	Diesel	SG	130	2999	F1CE3481E

Peugeot

Manufacturer	Model	Type	EG-BE-No.
Peugeot	Boxer	100/130	e3 * 2007 / 46 * 0045 * ...

Motorisation	Fuel	Transmission type	Output in kW	Displacement in cm ³	Engine code
2.2 HDI	Diesel	SG	74	2198	4HY
2.2 HDI	Diesel	SG	96	2198	4HH

Citroen

Manufacturer	Model	Type	EG-BE-No.
Citroen	Jumper	110 / 130 / 150	e3 * 2007 / 46 * 0046 * ...

Motorisation	Fuel	Transmission type	Output in kW	Displacement in cm ³	Engine code
2.2 HDI	Diesel	SG	81	2198	4H03/4HG
2.2 HDI	Diesel	SG	96	2198	4H03/4HH
2.2 HDI	Diesel	SG	110	2198	4H03/4HJ

SG = Manual transmission

From Model Year 2012

Left-hand drive vehicle

Verified equipment variants: Manual / automatic air-conditioning system

Not verified:

- Front fog lights
- Headlight washer system
- Start-Stop

Total installation time: approx. 8.5 hours

Table of Contents

Validity	1	Preparing Installation Location	18
Necessary Components	2	Exhaust Gas Part 1	20
Installation Overview	2	Combustion Air	22
Information on Total Installation Time	2	Coolant Circuit 2.0 D / 2.2 HDI / 2.3 D	23
Information on Operating and Installation Instructions	3	Coolant Circuit 3.0 D	24
Information on Validity	4	Fuel	31
Technical Information	4	Exhaust Gas Part 2	34
Explanatory Notes on Document	4	Final Work	35
Preliminary Work	5	Template for Fuel Standpipe	36
Heater Installation Location	5	Template for Bracket	37
Dismantling Instructions from MY 2014	6	Operating Instructions for Manual Air-Conditioning	38
Preparing Electrical System	7	Operating Instructions Automatic Air-Conditioning	39
Electrical System	11		
Fan Controller for Manual Air-Conditioning	12		
Fan Controller for Automatic Air-Conditioning	14		
MultiControl CAR Option	17		
Remote Option (Telestart)	17		

Necessary Components

- Basic delivery scope of *Thermo Top Evo* based on price list
- Installation kit for Citroen Jumper / Fiat Ducato / Peugeot Boxer 2012 Diesel: **1318462C**
- Additionally required in case of automatic air-conditioning: Citroen Jumper automatic air-conditioning kit / Fiat Ducato / Peugeot Boxer 2012: **1318504B**
- Heater control in accordance with price list and upon consultation with end customer
- In case of Telestart, indicator lamp in accordance with price list and in consultation with end customer

Installation instructions:

- Arrange for the vehicle to be delivered with the tank only about ¼ full!
- The installation location of the push button in case of Telestart or Thermo Call should be confirmed with the end customer.
- Depending on the available space and manufacturer's instructions, we recommend the use of a vehicle battery with more electrical capacity.

Installation Overview

Legend:

1. Heater
2. Fuse holder of engine compartment
3. Passenger compartment relay and fuse holder
4. PWM GW (only in case of automatic air-conditioning)
5. Circulating pump
6. MultiControl CAR
7. Metering pump

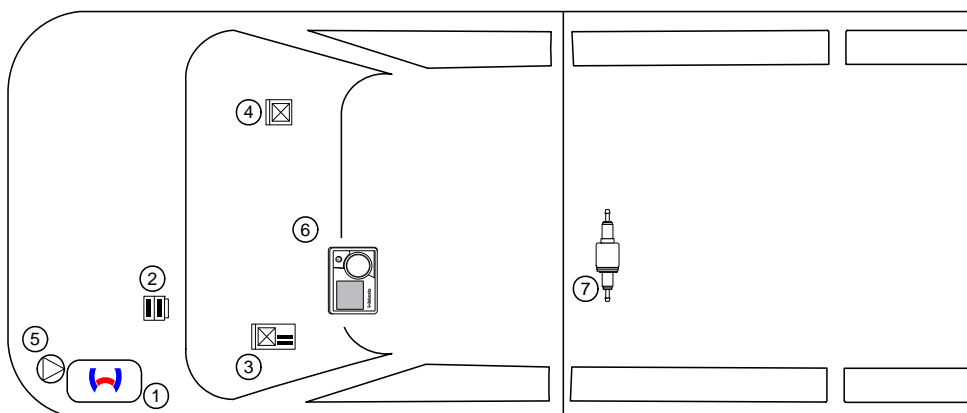

Information on Total Installation Time

The total installation time includes the time needed for mounting and demounting of the vehicle-specific components, the heater specific installation time and all other times required for the system integration and initial start-up of the heater.

The total installation time may vary for vehicle equipment other than provided.

Information on Operating and Installation Instructions

1 Important notes (not complete)

1.1 Installation and Repair



The improper installation or repairing of Webasto heating and cooling systems can cause fire or the leakage of deadly carbon monoxide, leading to serious injury or death.



To install and repair Webasto heating and cooling systems you need to have completed a special company training course and have the appropriate technical documentation, special tools and special equipment.



Installation and repair may ONLY be carried out by persons trained and certified in a Webasto training course. NEVER try to install or repair Webasto heating or cooling systems if you have not completed a Webasto training course, you do not have the necessary technical skills and you do not have the technical documentation, tools and equipment available to ensure that you can complete the installation and repair work properly.

Only use genuine Webasto parts. See the Webasto air and water heaters accessories catalogue for this purpose.

1.2 Operation

To ensure safe operation, we recommend having the heater checked every two years by an authorised Webasto dealer, especially when used over a long period and/or under extreme environmental conditions.

Do not operate the heater in closed rooms due to the danger of poisoning and suffocation.

Always switch off the heater before refuelling.

The heater may only be used with the prescribed fuel Diesel (DIN EN 590) or petrol (DIN EN 228).

The heater may not be cleaned with a high-pressure cleaner.

1.3 Please note

ALWAYS follow all Webasto installation and operating instructions and observe all warnings.

To become familiar with and understand all functions and properties of the heater, the operating instructions must be read carefully and observed at all times.

For proper, safe installation and repair work, the installation instructions with all warnings and safety information must be carefully read and observed at all times. Please always contact a workshop authorised by Webasto for all installation and repair work.

Important

Webasto shall assume no liability for defects, damage and injuries resulting from a failure to observe the installation, repair and operating instructions of the information contained in them.

This liability exclusion particularly applies to improper installations and repairs, installations and repairs by untrained persons or in the case of a failure to use genuine spare parts.

The liability due to culpable disregard to life, limb or health and due to damage or injuries caused by a wilful or reckless breach of duty remain unaffected, as does the obligatory product liability.

Installation should be carried out according to the general, standard rules of technology. Unless specified otherwise, fasten hoses, lines and wiring harnesses to original vehicle lines and wiring harnesses using cable ties. Insulate loose wire ends and tie back. Connectors on electronic components have to audibly click into place during installation.

Sharp edges should be fitted with rub protection. Spray unfinished body areas, e.g. drilled holes, with anti-corrosion wax (Tectyl 100K, Order No. 111329).

Observe the instructions and guidelines of the respective vehicle manufacturer for demounting and mounting vehicle specific components!

The initial startup is to be executed with the Webasto Thermo Test Diagnosis.

When installing a programmable control module (e.g. a PWM Gateway), the corresponding settings must be checked or adjusted.

2 Statutory regulations governing installation

Guidelines	Thermo Top Evo
Heating Directive ECE R122	E1 00 0258
EMC Directive ECE R10	E1 04 5627

Note

The regulations of these guidelines are binding in the scope of the Directive 70/156/EEC and/or 2007/46/EC (for new vehicle models from 29/04/2009) and should also be observed in countries in which there are no special regulations.

Important

Failure to follow the installation instructions will result in the invalidation of the type approval for the heater and therefore invalidation of the general **homologation of the vehicle**.

Note

The heater is licensed in accordance with paragraph 19, section 3, No. 2b of the StVZO (German Road Traffic Licensing Authority).

2.1 Excerpt from the directive 122 (heater) section 5 for the installation of the heater.

Beginning of excerpt.

ANNEX VII

REQUIREMENTS FOR COMBUSTION HEATERS AND THEIR INSTALLATION

1. GENERAL REQUIREMENTS

1.7.1. A clearly visible indicator in the operator's field of view shall inform when the combustion heater is switched on or off.

2. VEHICLE INSTALLATION REQUIREMENTS

2.1. Scope

2.1.1. Subject to paragraph 2.1.2. combustion heaters shall be installed according to the requirements of this Annex.

2.1.2. Vehicles of category O having liquid fuel heaters are deemed to comply with the requirements of this Annex.

2.2. Positioning of heater

2.2.1. Body sections and any other components in the vicinity of the heater must be protected from excessive heat and the possibility of fuel or oil contamination.

2.2.2. The combustion heater shall not constitute a risk of fire, even in the case of overheating. This requirement shall be deemed to be fulfilled if the installation ensures an adequate distance to all parts and suitable ventilation, by the use of fire resistant materials or by the use of heat shields.

2.2.3. In the case of M2 and M3 vehicles, the heater must not be positioned in the passenger compartment. However, an installation in an effectively sealed envelope which also complies with the conditions in paragraph 2.2.2 may be used.

2.2.4. The label referred to in paragraph 1.4 or a duplicate, must be positioned so that it can be easily read when the heater is installed in the vehicle.

2.2.5. Every reasonable precaution should be taken in positioning the heater to minimise the risk of injury and damage to personal property.

2.3. Fuel supply

2.3.1. The fuel filler must not be situated in the passenger compartment and must be provided with an effective cap to prevent fuel spillage

2.3.2. In the case of liquid fuel heaters, where a supply separate to that of the vehicle is provided, the type of fuel and its filler neck must be clearly labelled

2.3.3. A notice, indicating that the heater must be shut down before refuelling, must be affixed to the filler neck. In addition a suitable instruction must be included in the manufacturer's operating manual.

2.4. Exhaust system

2.4.1. The exhaust gas outlet must be located so as to prevent emissions from entering the vehicle through ventilators, heated air inlets or opening windows.

2.5. Combustion air inlet

2.5.1. The air for the combustion chamber of the heater must not be drawn from the passenger compartment of the vehicle.

2.5.2. The air inlet must be so positioned or guarded that blocking by rubbish or luggage is unlikely.

2.6. Heating air inlet

2.6.1. The heating air supply may be fresh or recirculated air and must be drawn from a clean area not likely to be contaminated by exhaust fumes emitted either by the propulsion engine, the combustion heater or any other vehicle source.

2.6.2. The inlet duct must be protected by mesh or other suitable means.

2.7. Heating air outlet

2.7.1. Any ducting used to route the hot air through the vehicle must be so positioned or protected that no injury or damage could be caused if it were to be touched.

2.7.2. The air outlet must be so positioned or guarded that blocking by rubbish or luggage is unlikely.

End of excerpt.

In multilingual versions the German language is binding.

Citroen Jumper / Fiat Ducato / Peugeot Boxer

Information on Validity

This installation documentation applies to Citroen Jumper / Fiat Ducato / Peugeot Boxer Diesel vehicles - for validity, see page 2 - from model year 2012 and later, assuming technical modifications to the vehicle do not affect installation, any liability claims excluded. Depending on the vehicle version and equipment, modifications may be necessary during installation with respect to this installation documentation.

Vehicle and engine types, equipment variants and other specifications not listed in this installation documentation have not been tested. However, installation according to this installation documentation may be possible.

Technical Information

Special Tools

- Hose clamp pliers for auto-tightening hose clamps
- Hose clamp pliers for Clic hose clamps of type W
- Automatic wire stripper 0.2 - 6mm²
- Crimping pliers for cable lug / tab connector 0.5 - 6mm²
- Torque wrench for 2.0 - 10 Nm
- Hose clamping pliers
- Metric thread-setter kit
- Webasto Thermo Test Diagnosis with current software

Dimensions

- All dimensions in mm.



Tightening torque values

- Tightening torque values of 5x13 heater bolts = 8Nm.
- Tightening torque values of 5x15 retaining plate of water connection piece bolts = 7Nm.
- Tighten other bolt connections in accordance with manufacturer's instructions or in accordance with state-of-the-art-technology.

Explanatory Notes on Document

You will find an identification mark on the outside top right corner of the page in question to provide you with a quick overview of the individual working steps.

Special features are highlighted using the following symbols:

Mechanical system		Specific risk of injury or fatal accidents	
Electrical system		Specific risk due to electrical voltage	
Coolant circuit		Specific risk of damage to components	
Combustion air		Specific risk of fire or explosion	
Fuel		Reference to general installation instructions of the Webasto components or to the manufacturer's vehicle-specific documents	
Exhaust gas		Reference to a special technical feature	
Software		The arrow in the vehicle icon indicates the position on the vehicle and the viewing angle	
		Tightening torque according to the manufacturer's vehicle-specific documents	

Citroen Jumper / Fiat Ducato / Peugeot Boxer

Preliminary Work

Vehicle

- Open the fuel tank cap.
- Ventilate the fuel tank.
- Close the fuel tank cap again.
- Depressurise the cooling system.
- Disconnect the battery.
- Remove the underride protection on the right and on the left, if present.
- Detach the upper wing trim on the left and right, if present (see the dismantling instructions).
- If the wing trim is present, remove the wheel well trim on the left and on the right, otherwise detach only on the front left side.
- Remove the left and right-hand headlight.
- Remove the radiator grille and bumper trim (see the dismantling instructions).
- Detach the fuse and relay box (only with Telestart).
- Remove the lower footwell trim on the front passenger's side (only with automatic air-conditioning).

The following work should only be performed during the corresponding installation sequence:

- Open the right-hand tank-fitting service lid.
- Remove the fuel-tank sending unit in accordance with the manufacturer's instructions.

Heater

- Remove years that do not apply from the type and duplicate label.
- Attach the duplicate label (type label) in the appropriate place in the engine compartment.

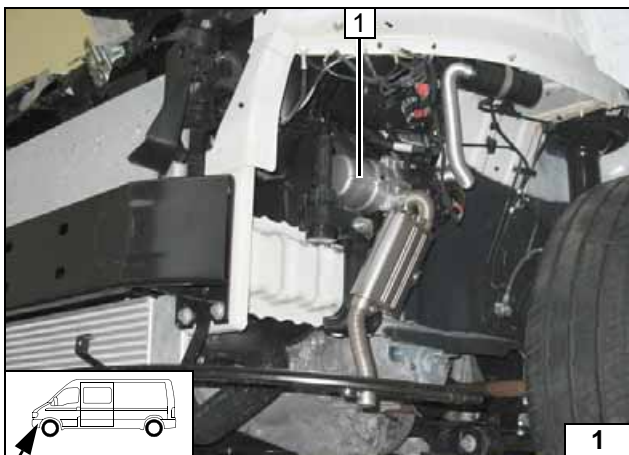

Heater Installation Location

- 1 Heater

Installation location

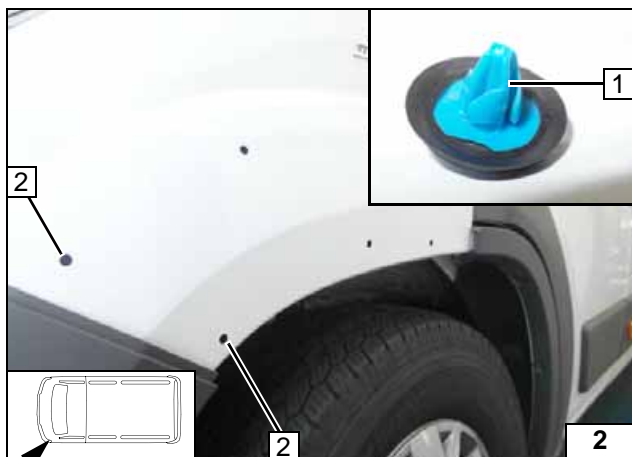

Dismantling Instructions from MY 2014

Fiat Ducato

Only needed if there is wing trim.
Remove retaining clip 1 [2x] at position 2 and take care not to damage the locking tab!

Detaching upper wing trim on the left and right

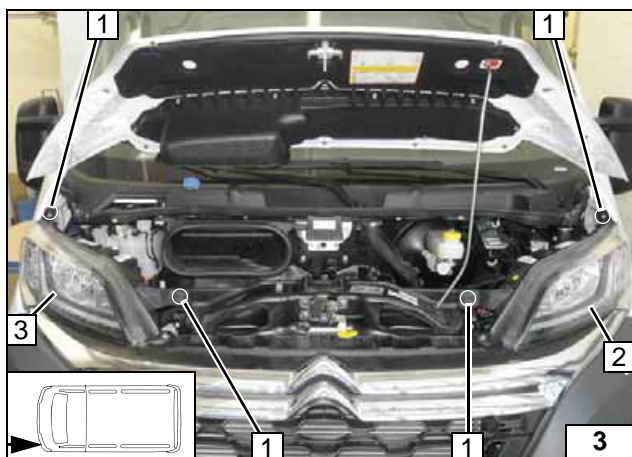

Citroen Jumper and Fiat Ducato

Further dismantling instructions are demonstrated on a Citroen Jumper but shall also apply for a Fiat Ducato!

- 1 Remove bolts [4x]
- 2 Left headlight
- 3 Right headlight

Removing headlights on the right and on the left

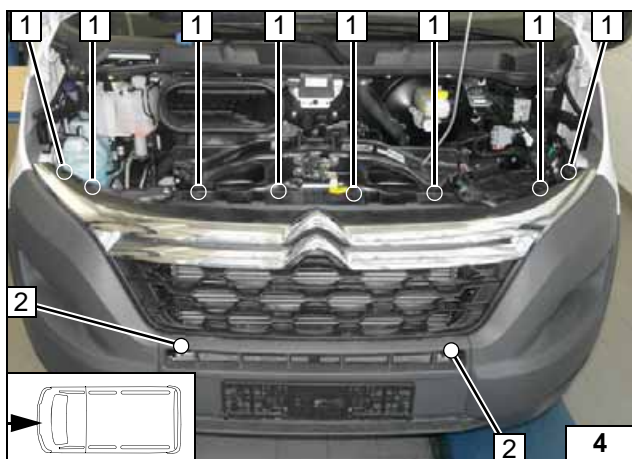

- 1 Remove bolts [8x]
- 2 Remove bolts (hidden) [2x]

Removing radiator grille

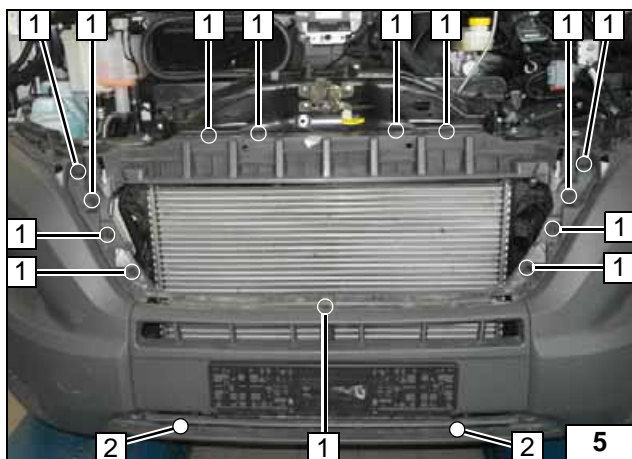

- 1 Remove bolts [13x]
- 2 Remove bolts (hidden) [2x]

Removing middle section of front bumper trim

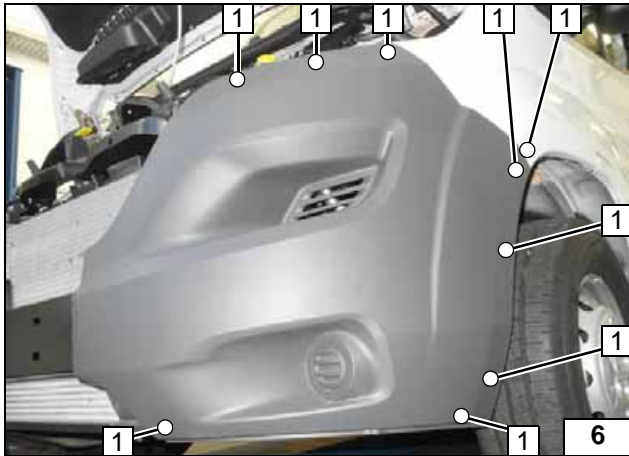

1 Remove bolts (hidden) [9x]

Removing left section of front bumper trim

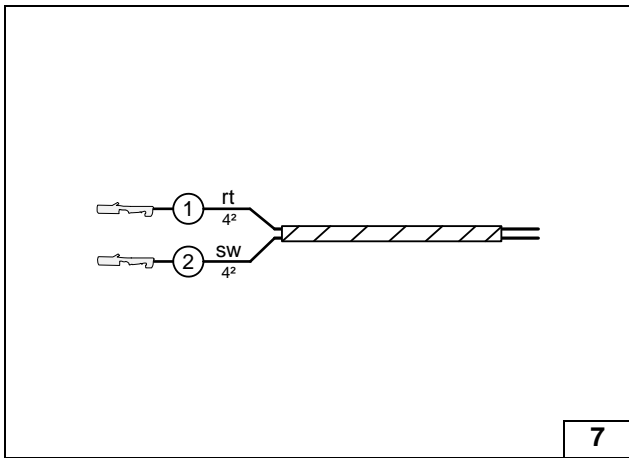

Preparing Electrical System

Wire sections retain their numbering throughout the entire document.

Manual air-conditioning system

- ① Red (rt) wire of fan wiring harness
- ② Black (sw) wire of fan wiring harness



Preparing wires

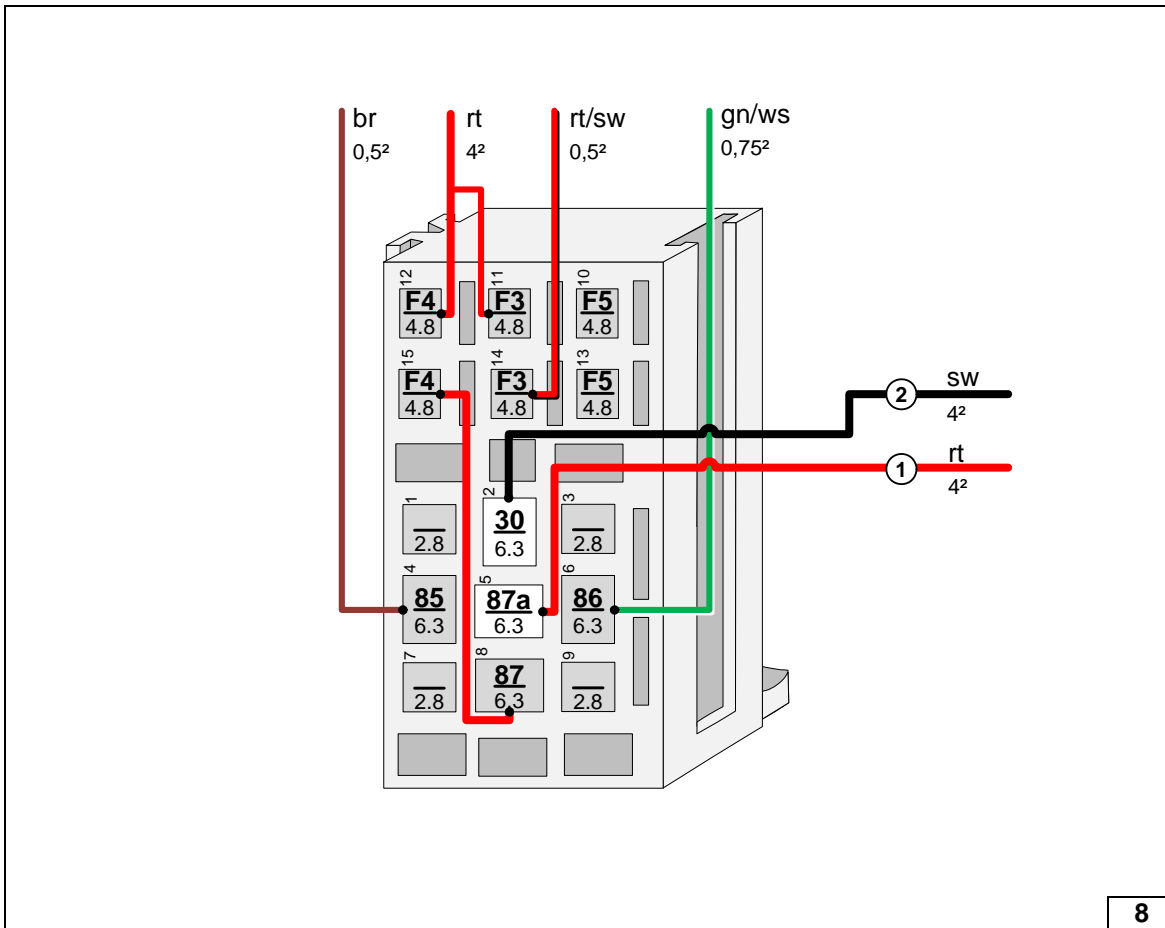

Connecting wires to passenger compartment relay and fuse holder



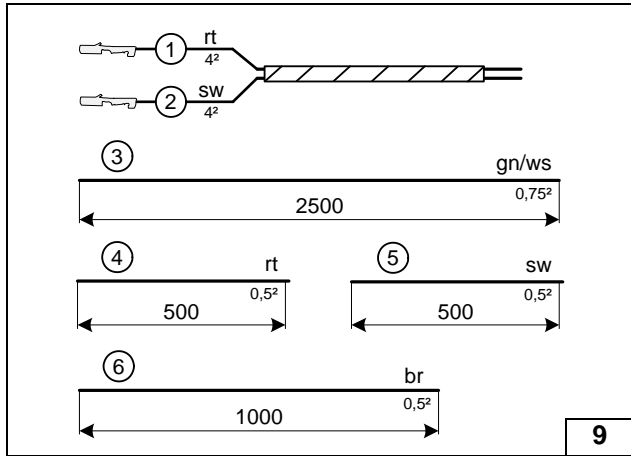
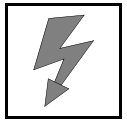

Automatic air-conditioning system

Pull wire section ③ into provided protective sleeving.

- ① Red (rt) wire from K1/87a, fan wiring harness
- ② Black (sw) wire from K1/30, fan wiring harness



Preparing wires

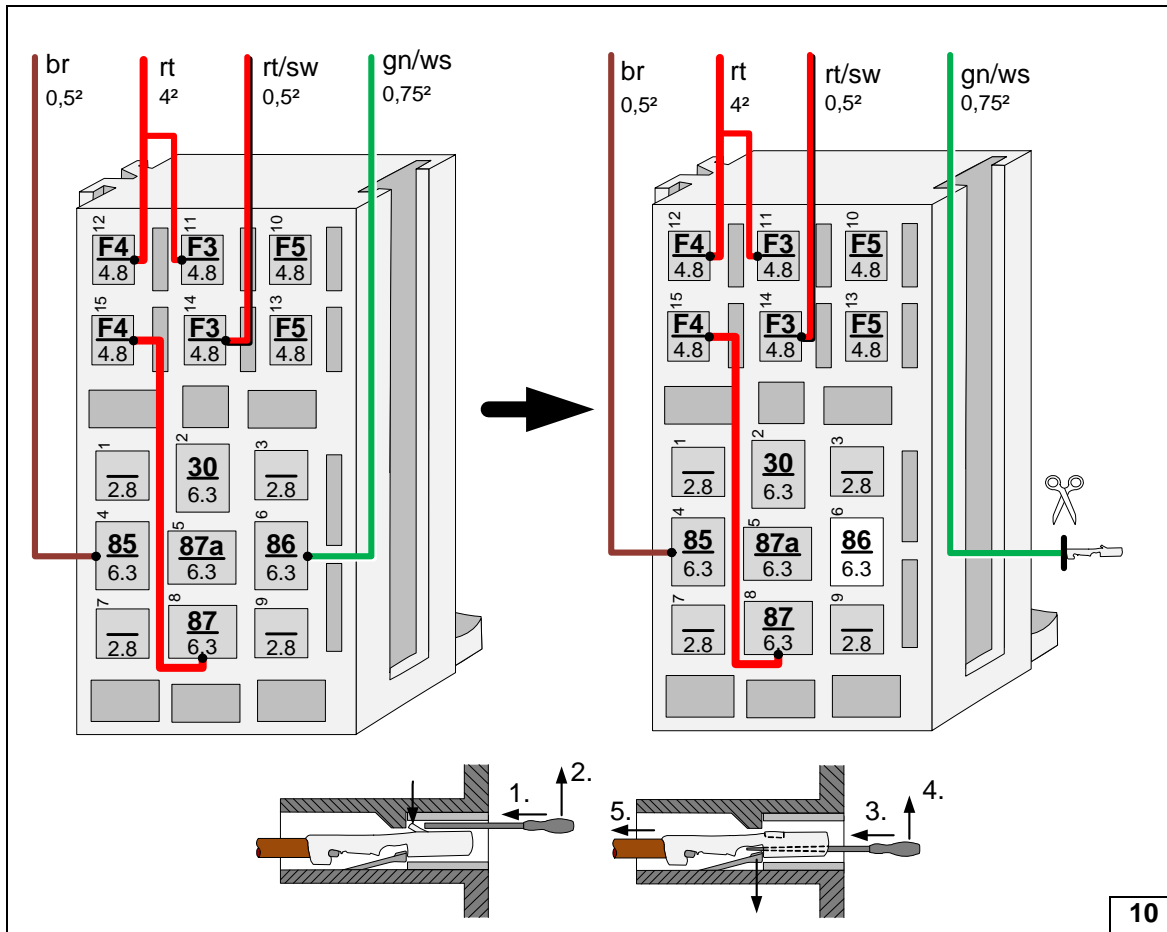

Preparing passenger compartment relay and fuse holder

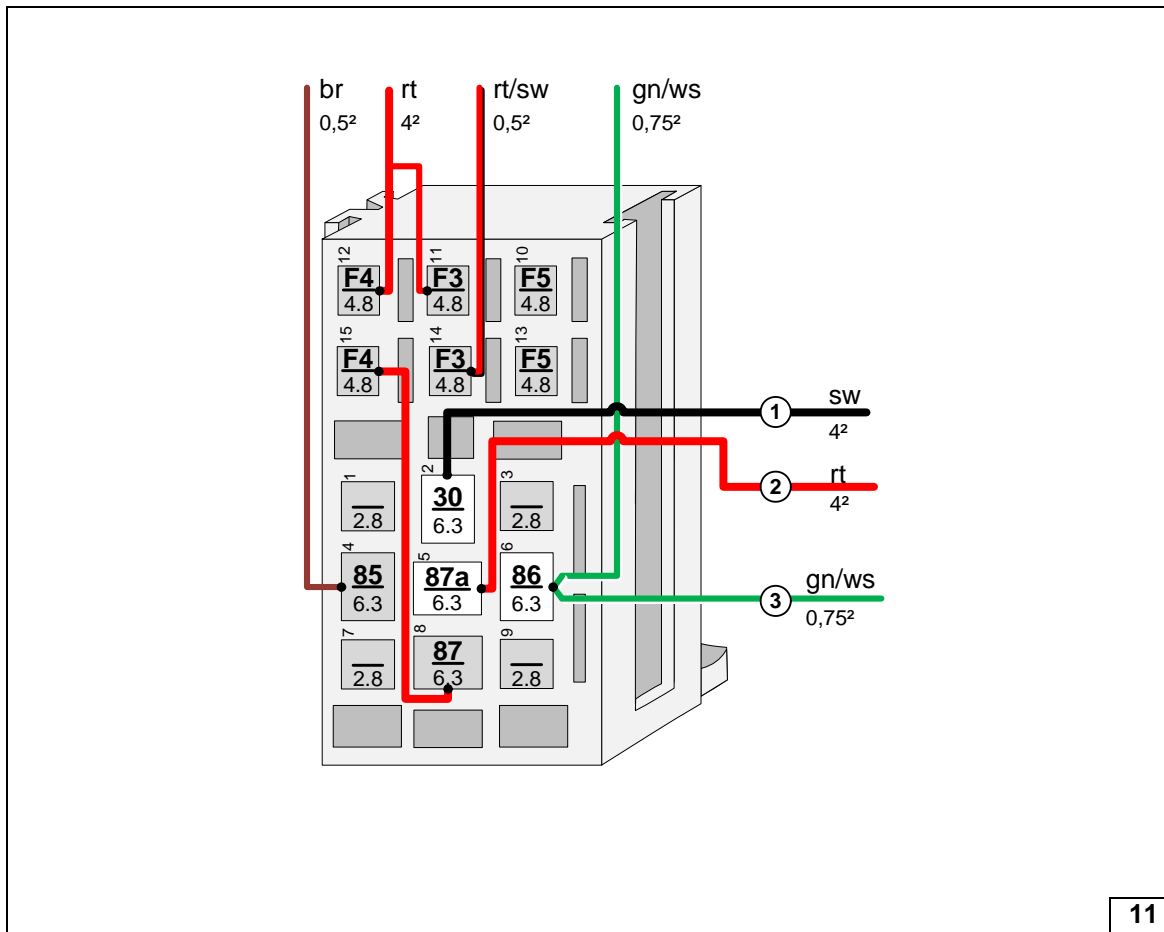

Connecting wires to passenger compartment relay and fuse holder

11

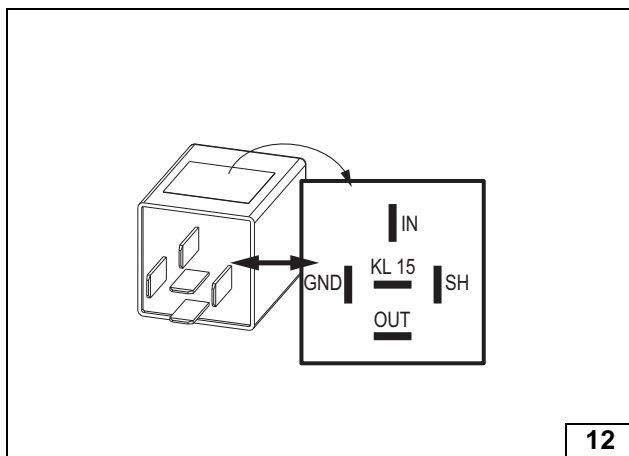

Check the PWM Gateway settings when starting up the heater and adjust if necessary.



Settings:

- Duty cycle: 35%
- Frequency: 1200Hz
- Voltage: 4.2V
- Function: High side

View of PWM-GW

12

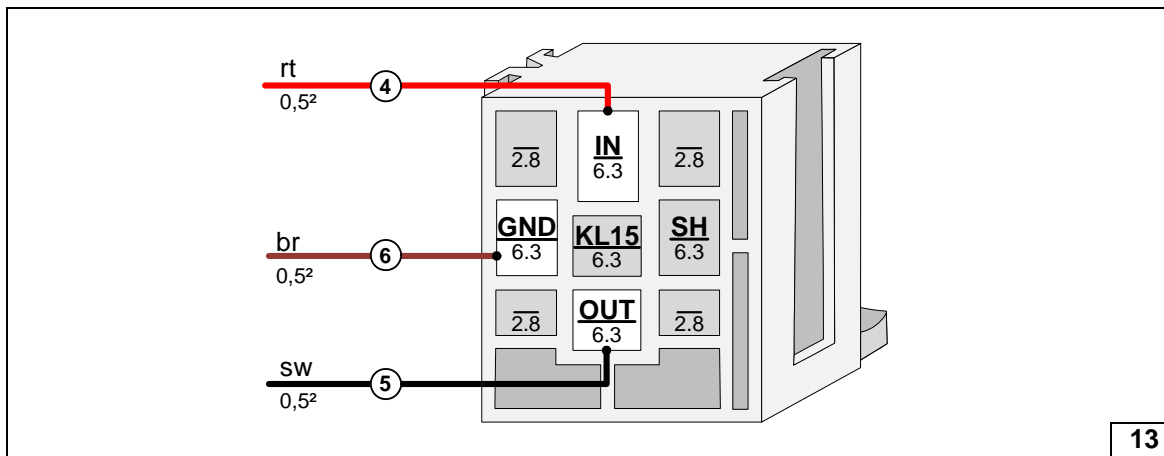

Connecting wires to PWM GW socket

13

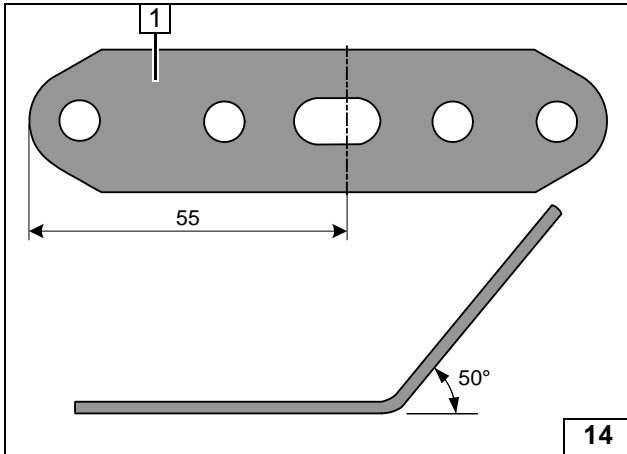

All vehicles

- 1 Perforated bracket

Preparing perforated bracket

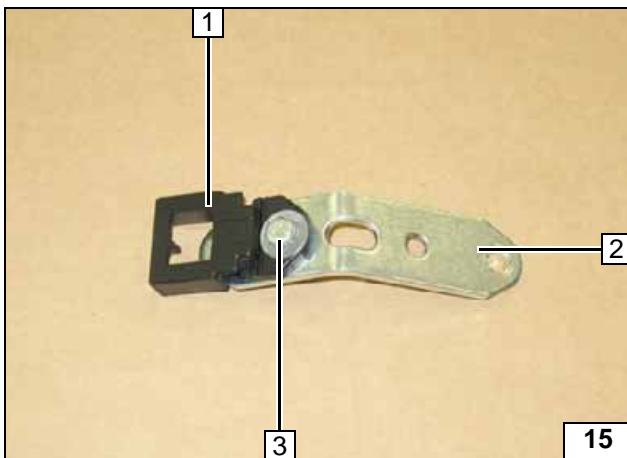

- 1 Retaining plate of engine compartment fuse holder
- 2 Perforated bracket
- 3 M5x16 bolt, large diameter washer [2x], nut

Premounting perforated bracket

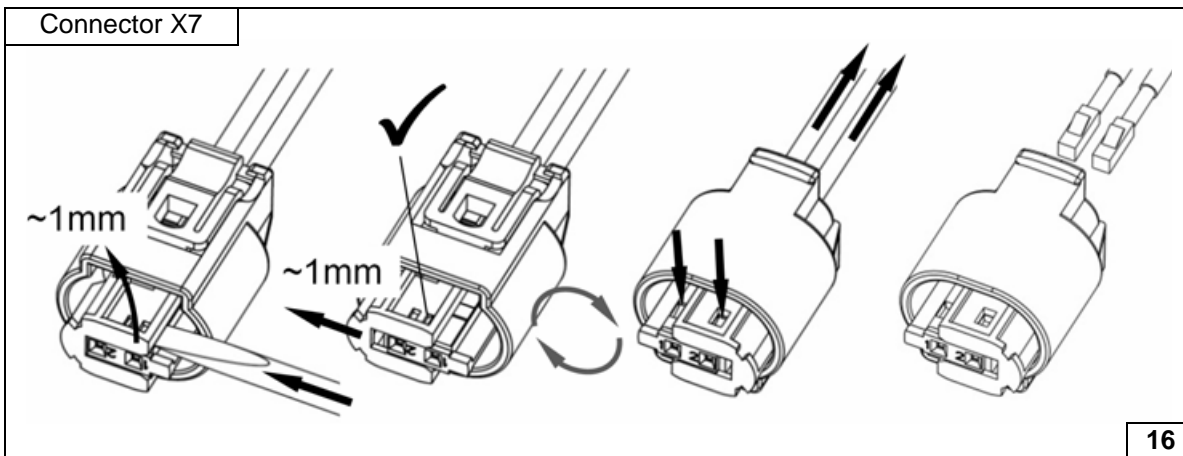

Dismantling connector of metering pump

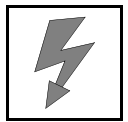

Electrical System

Positive wire

- 1 Positive wire on positive distributor

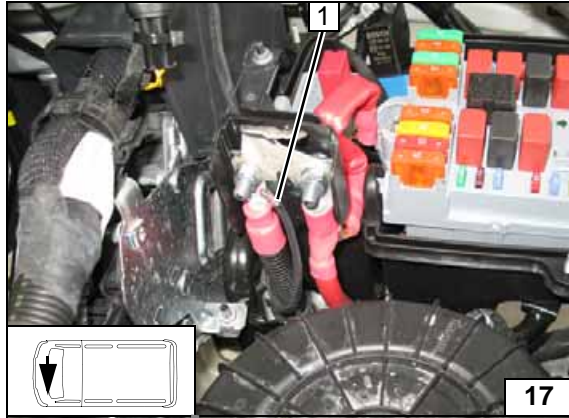

Fuse holder of engine compartment

- 1 M6x20 bolt, flanged nut, existing hole
- 2 Perforated bracket
- 3 F1-2 fuses

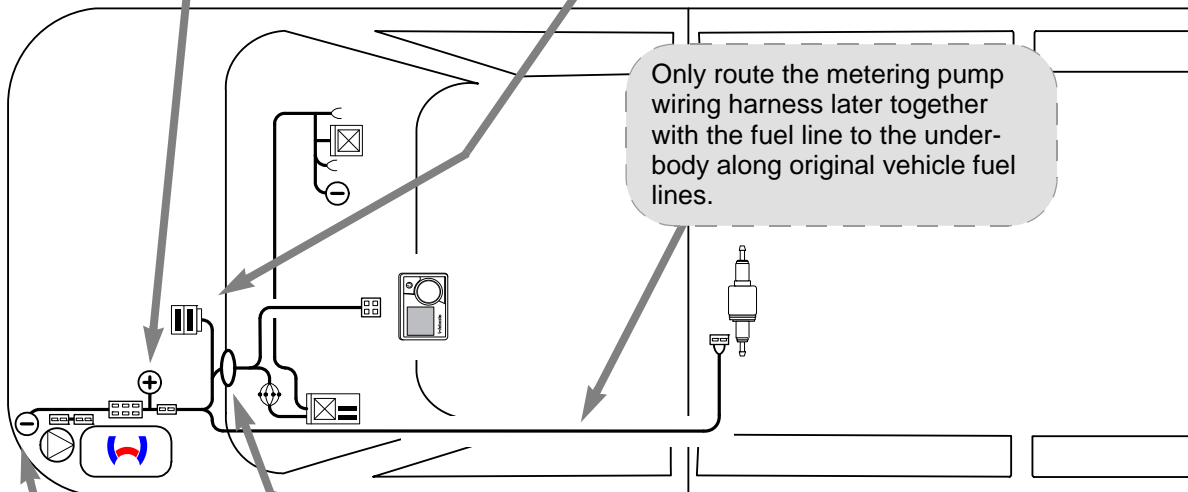
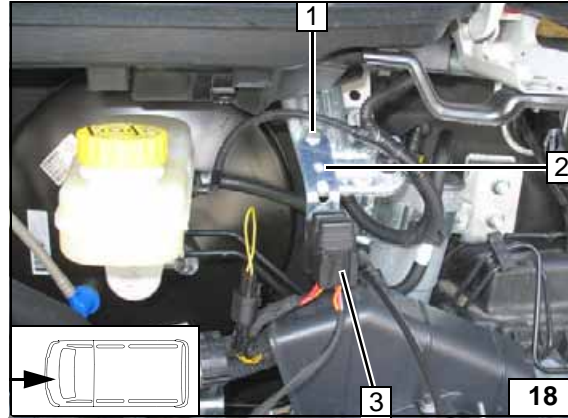

Wiring harness routing diagram

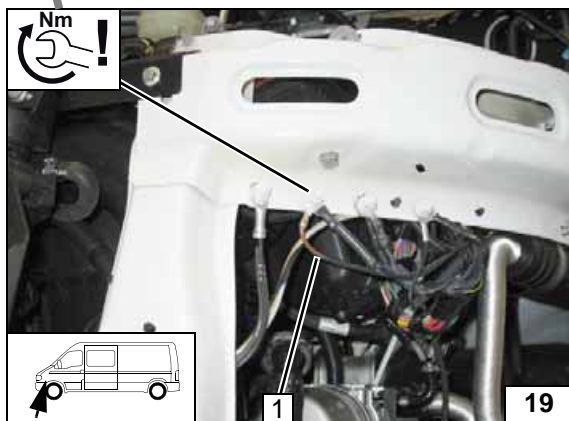

Earth wire

- 1 Earth wire on original vehicle earth support point

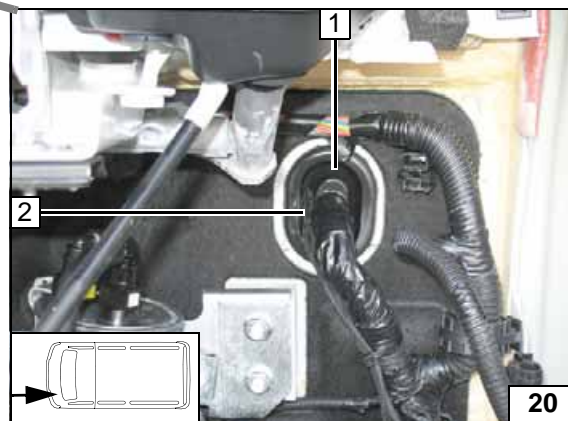

Wiring harness pass through

- 1 Protective rubber plug
- 2 Wiring harnesses of heater, heater control





Fan Controller for Manual Air-Conditioning

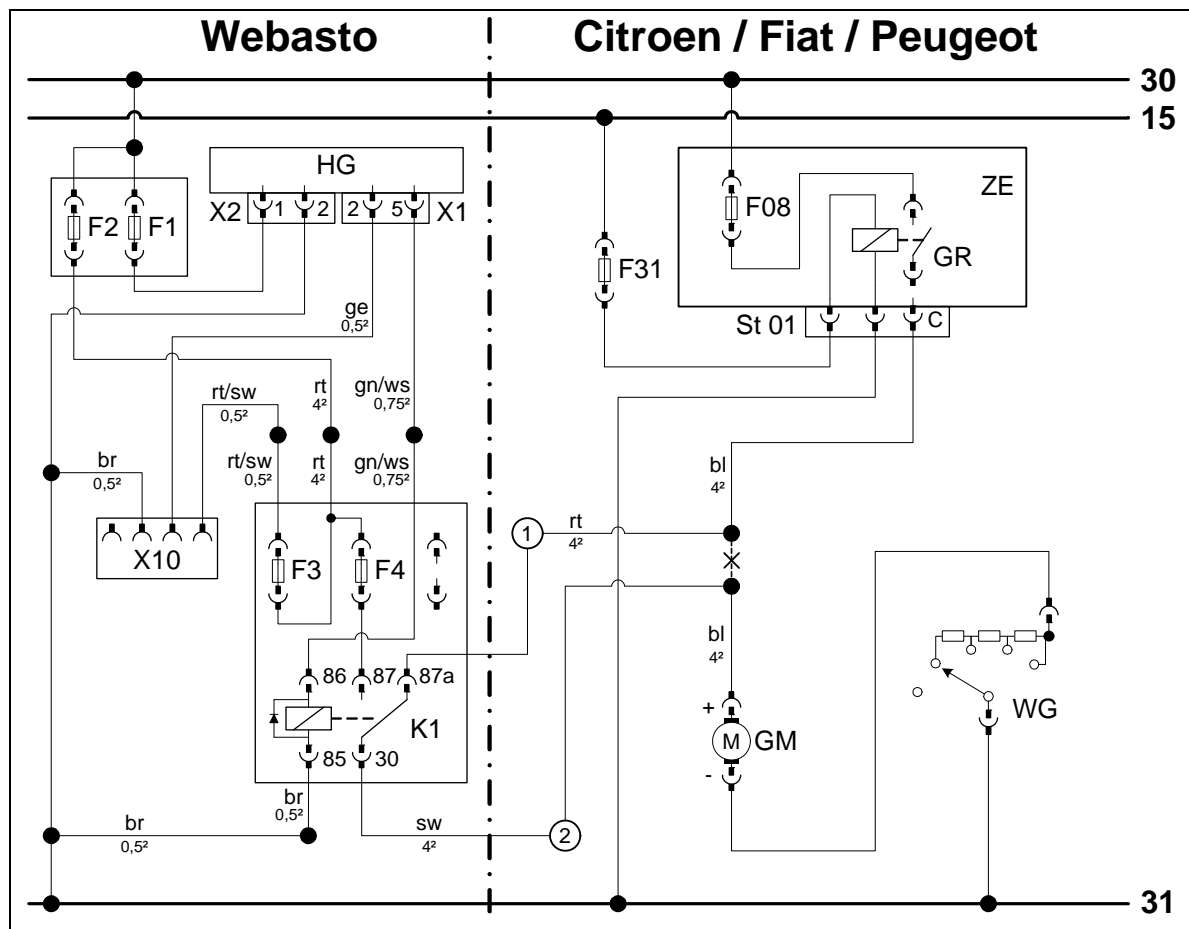

Wiring diagram

Webasto components		Vehicle components		Colours and symbols	
HG	TT-Evo heater	ZE	Central electrical box	rt	red
X1	6-pin heater connector	GR	Fan relay	sw	black
X2	2-pin heater connector	F08	40A fuse	ge	yellow
F1	20A fuse	St 01	3-pin connector, grey	gn	green
F2	30A fuse	F31	7.5A fuse	bl	blue
X10	4-pin connector of heater control	WG	Resistor group	ws	white
F3	1A fuse	GM	Fan motor	br	brown
F4	25A fuse				
K1	Fan relay				
				X	Cutting point
				Wiring colours may vary.	

Legend

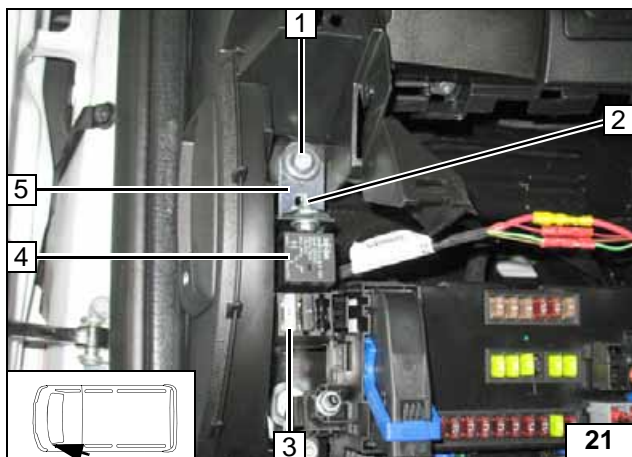

- 1 Original vehicle bolt
- 2 M5x16 bolt, large diameter washer [2x], nut
- 3 25A fuse F4 inserted
- 4 K1 relay mounted
- 5 Angle bracket

Mounting passenger compartment relay and fuse holder

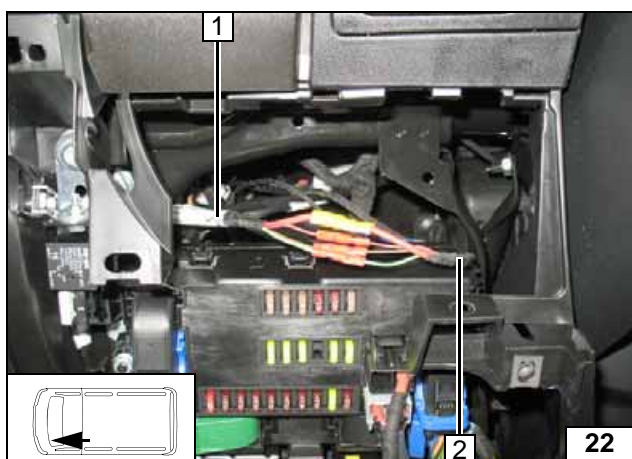

- 1 Wiring harness of passenger compartment relay and fuse holder
- 2 Wiring harness of heater

Connecting same colour wires of wiring harnesses

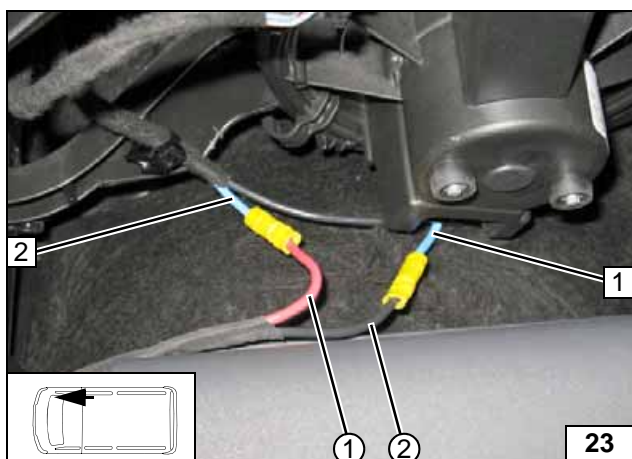

Connection to fan motor connector. Produce connections as shown in wiring diagram.



- 1 Blue (bl) wire of connector GM
- 2 Blue (bl) wire of fan relay
- ① Red (rt) wire from K1/87a, fan wiring harness
- ② Black (sw) wire from K1/30, fan wiring harness

Connecting fan motor



Fan Controller for Automatic Air-Conditioning

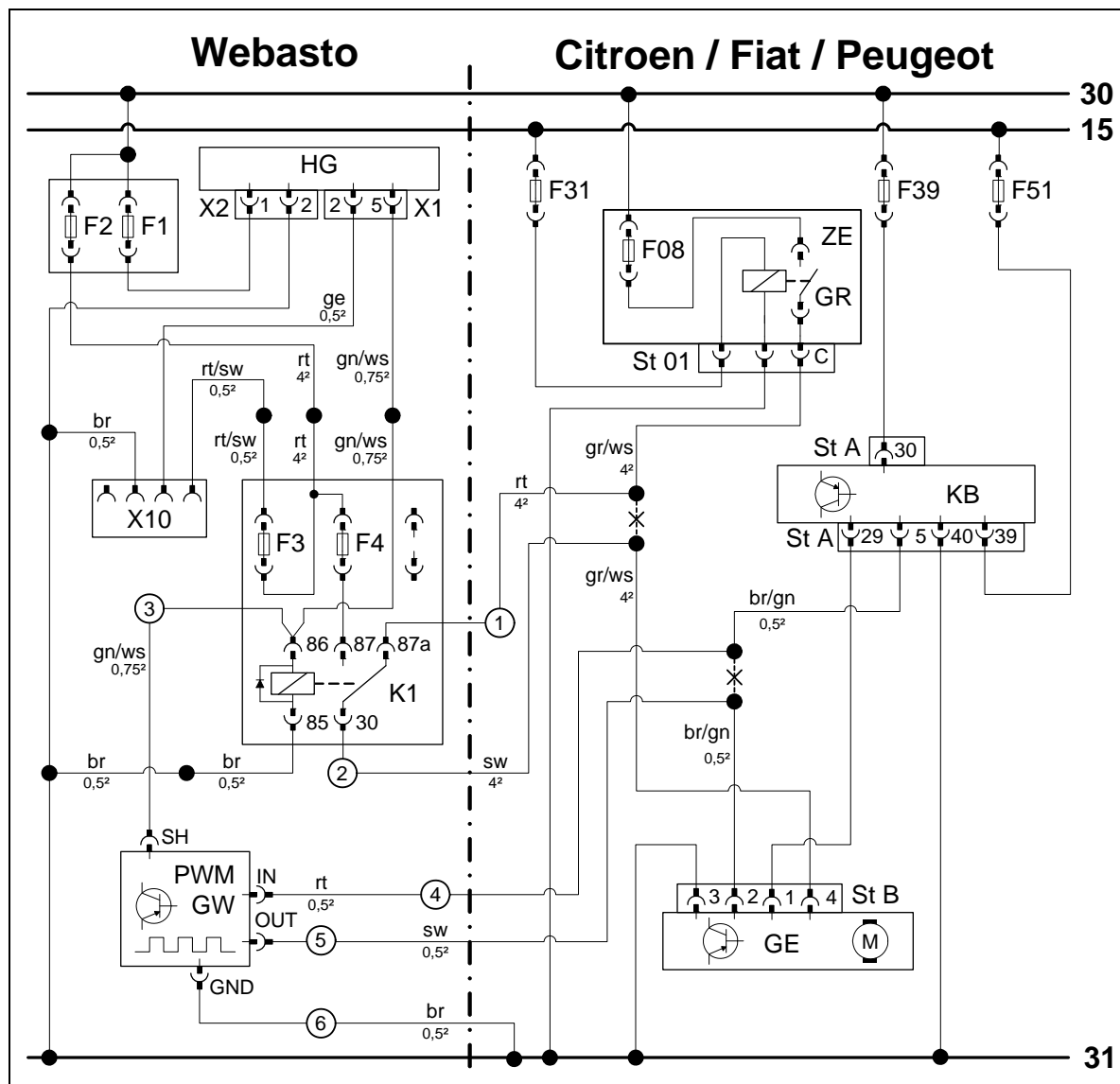

Wiring diagram

Webasto components		Vehicle components		Colours and symbols	
HG	TT-Evo heater	F31	7.5A fuse	rt	red
X1	6-pin heater connector	F39	10A fuse	sw	black
X2	2-pin heater connector	F51	7.5A fuse	ge	yellow
F1	20A fuse	ZE	Central electrical box	gn	green
F2	30A fuse	F08	40A fuse	bl	blue
X10	4-pin connector of heater control	GR	Fan relay	ws	white
F3	1A fuse	St 01	3-pin connector	br	brown
F4	25A fuse	KB	A/C control panel	gr	grey
K1	Fan relay	St A	40-pin connector KB		
PWM	Pulse width modulator	GE	Fan unit		
GW		St B	6-pin connector GE		
Settings of PWM GW:					
Duty cycle: 35%					
Frequency: 1200Hz					
Voltage: 4.2V				X	Cutting point
Function: High side				Wiring colours may vary.	

Legend

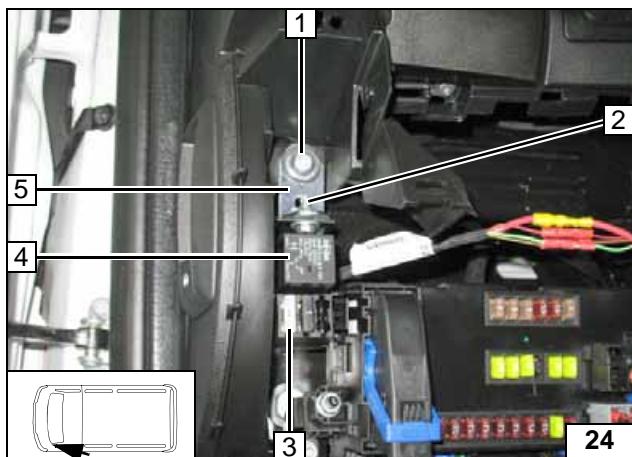

- 1 Original vehicle bolt
- 2 M5x16 bolt, large diameter washer [2x], nut
- 3 25A fuse F4 inserted
- 4 K1 relay mounted
- 5 Angle bracket

Mounting passenger compartment relay and fuse holder

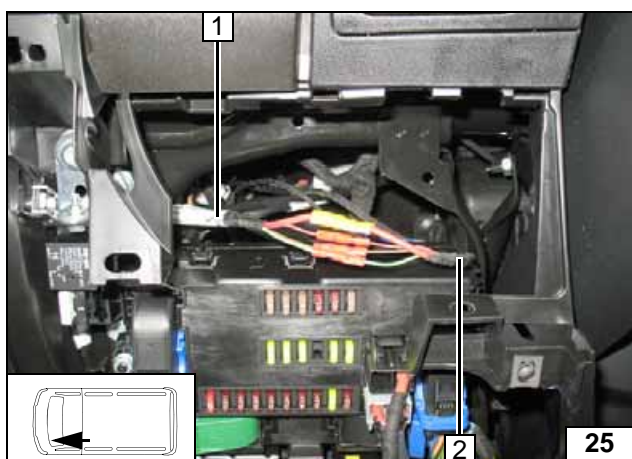

- 1 Wiring harness of passenger compartment relay and fuse holder
- 2 Wiring harness of heater

Connecting same colour wires of wiring harnesses

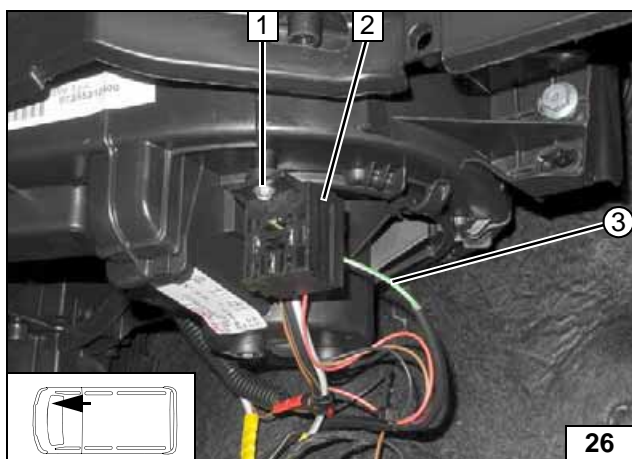

- 1 Original vehicle bolt of fan motor
- 2 PWM GW socket
- ③ Green/white (gn/ws) additional wire of K1/86 and PWM GW/SH

Installing PWM GW socket

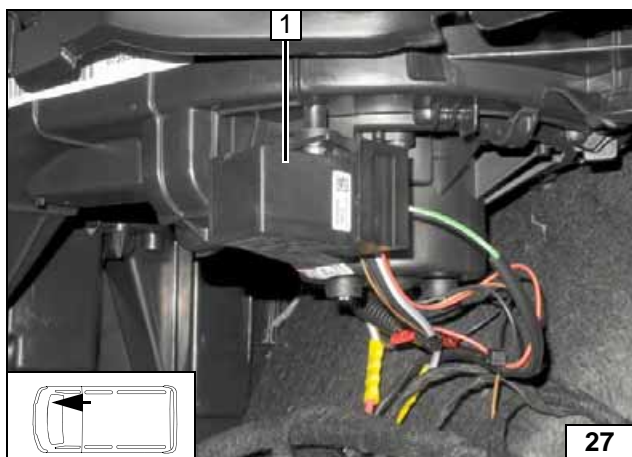

- 1 PWM GW

Inserting PWM GW

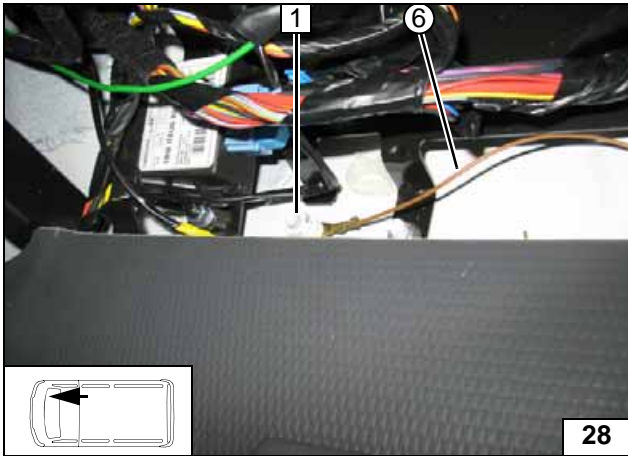
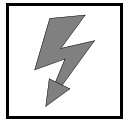

PWM GW earth connection

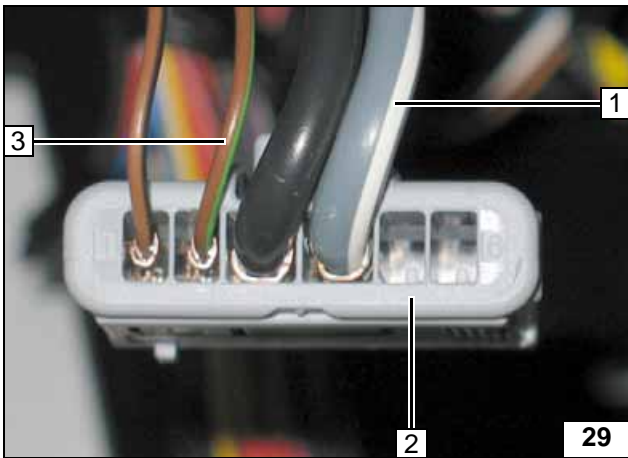

View of fan unit connector

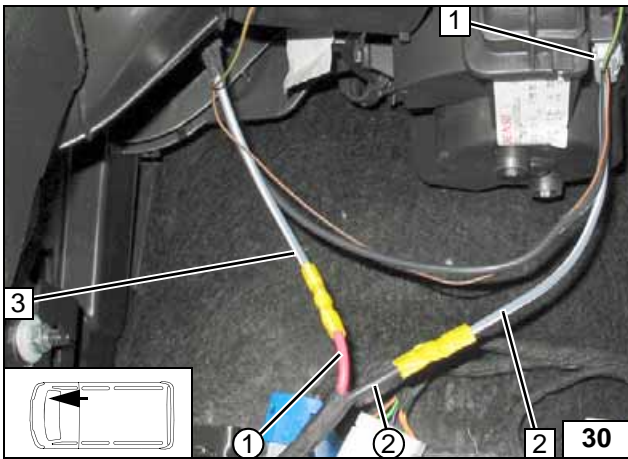

Connecting fan unit

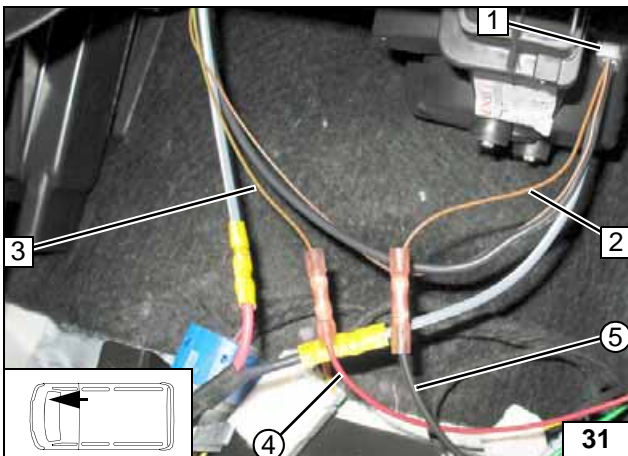

Connecting fan unit

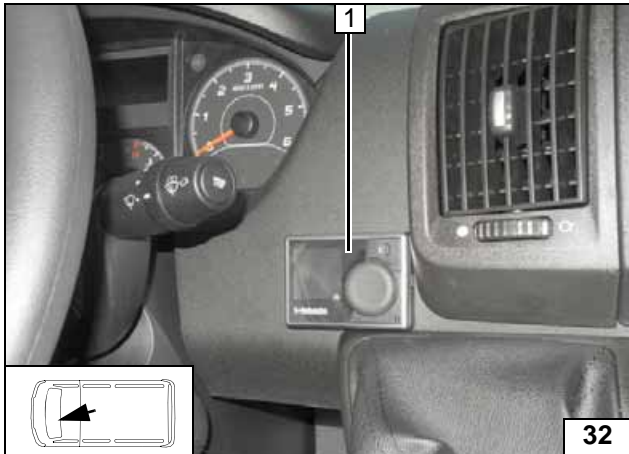

MultiControl CAR Option

- 1 MultiControl CAR



Installing MultiControl CAR

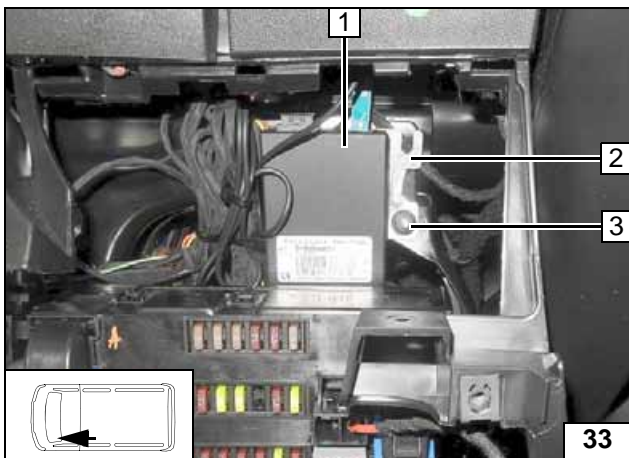

Remote Option (Telestart)

- 1 Receiver
- 2 Bracket
- 3 M5x16 bolt, flanged nut, existing hole



Installing receiver

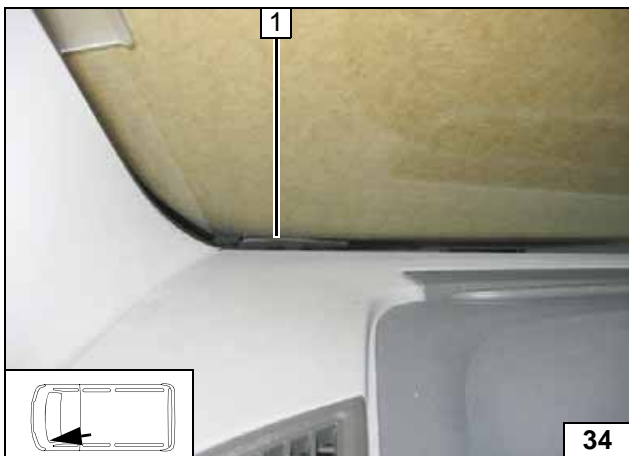

- 1 Antenna

Installing antenna

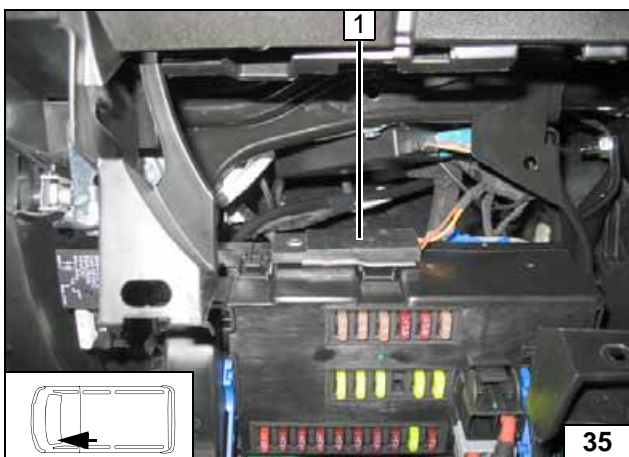

Temperature sensor T100 HTM

Fasten temperature sensor 1 with adhesive tape.



Installing temperature sensor



Preparing Installation Location

Existing holes at position 1 [3x] are vehicle-dependent, drill out to Ø 8.5 mm dia. if necessary!



Hole pattern of bracket

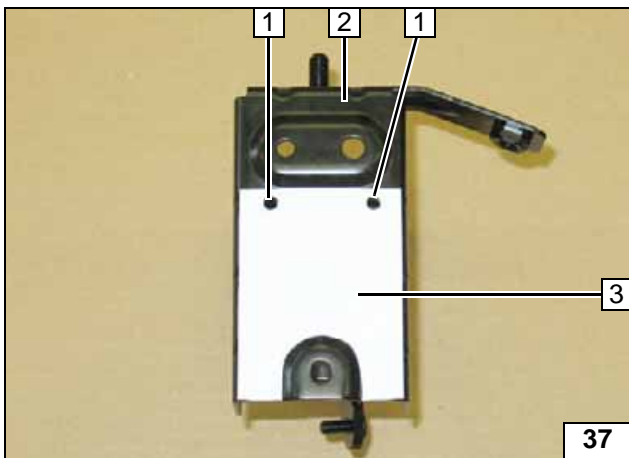

Cut out template 3 and place!

- 1 Copy hole pattern, 7mm dia. hole [2x each]
- 2 Bracket



Preparing bracket

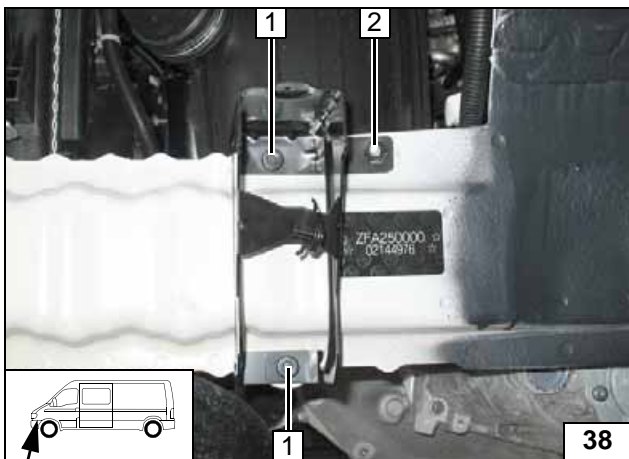

- 1 M8 flanged nut [2x] (hidden)
- 2 M8x20 bolt, spring lockwasher (hidden)

Installing bracket

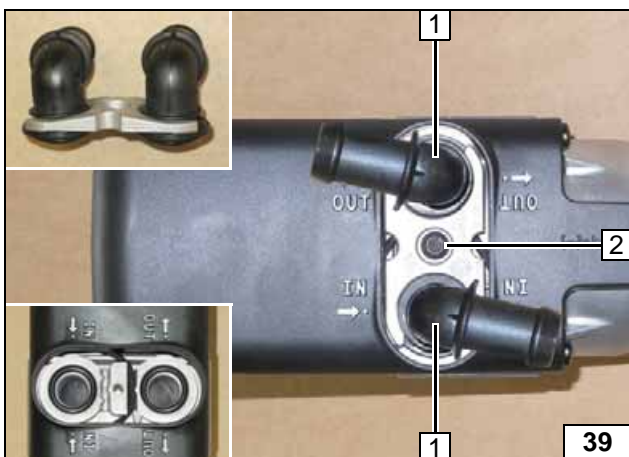

Preparing heater

- 1 Water connection piece, sealing ring [2x each]
- 2 5x15 self-tapping bolt, retaining plate of water connection pieces



Installing water connection pieces

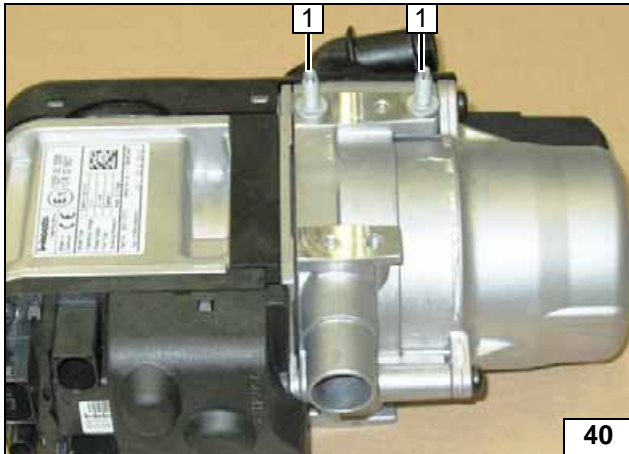

- 1 Self-tapping stud bolt [2x]

Premounting stud bolts

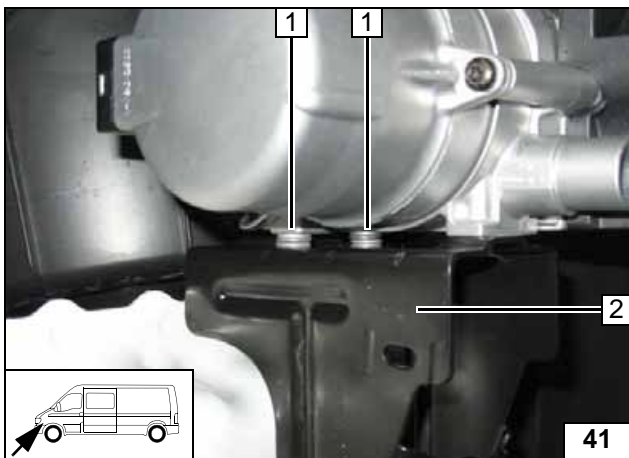

Installing heater

Insert two washers each at position 1 to serve as height compensation.



- 2 Bracket

Inserting heater into bracket

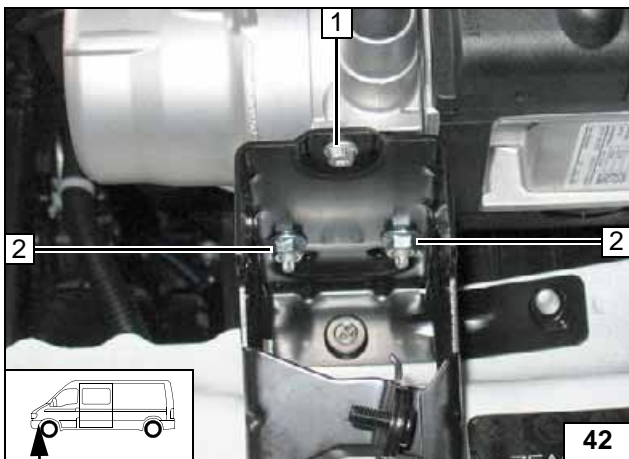

- 1 5x13 self-tapping bolt
- 2 M6 flanged nut [2x]

Mounting heater

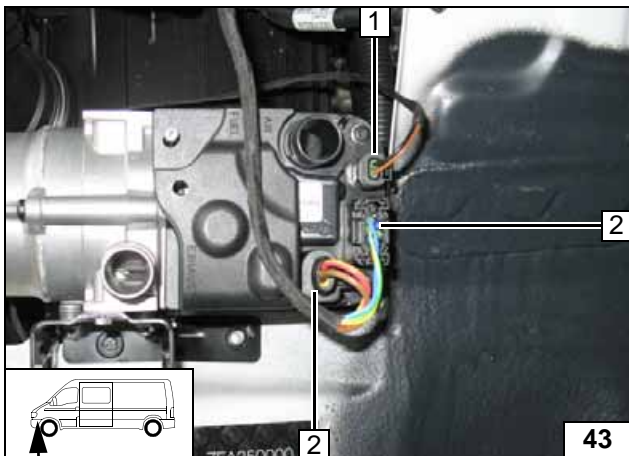

- 1 Connector of circulating pump wiring harness
- 2 Heater wiring harness connector [2x]

Mounting wiring harnesses

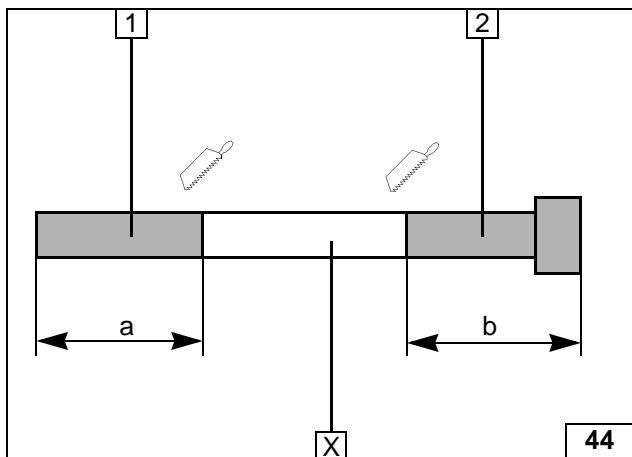
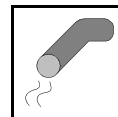

Exhaust Gas Part 1

Discard section X.

- 1 Exhaust pipe
a = 100
- 2 Exhaust end section
b = 170



Preparing exhaust pipe

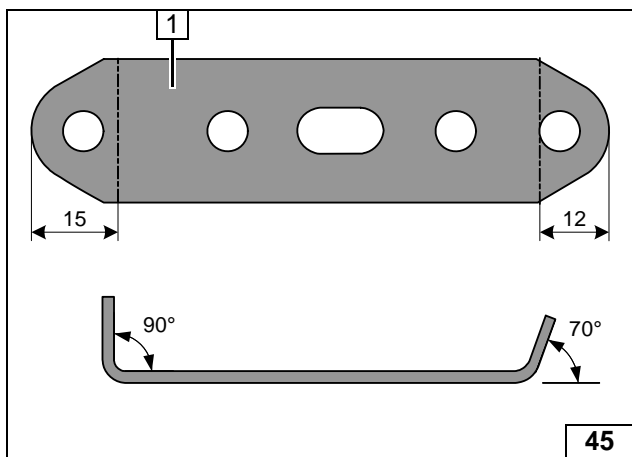

- 1 Perforated bracket



Angling down perforated bracket

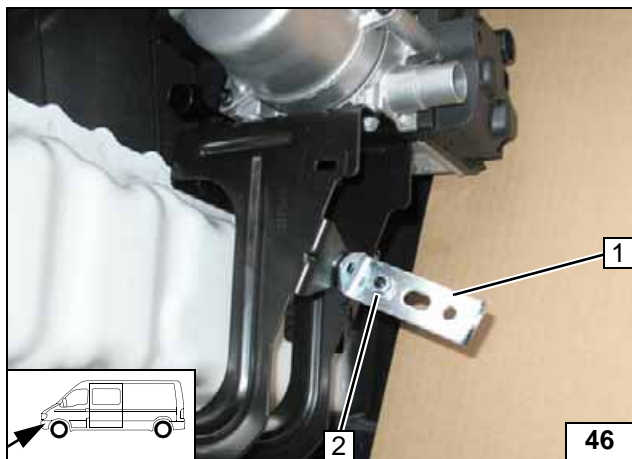

- 1 Perforated bracket
- 2 Flanged nut, stud bolt of bracket

Installing perforated bracket

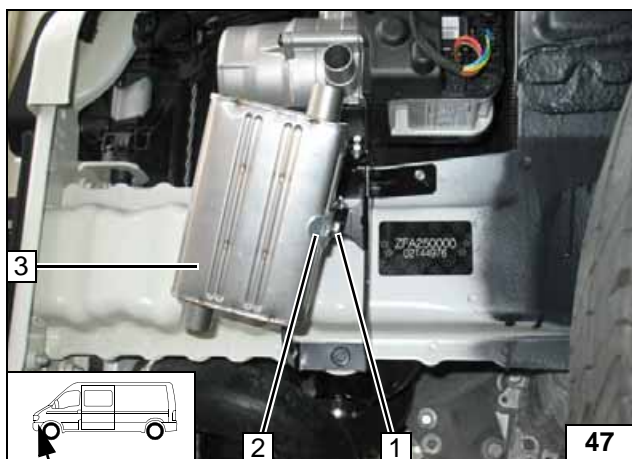

- 1 M6x16 bolt, spring lockwasher
- 2 Perforated bracket
- 3 Exhaust silencer

Mounting silencer

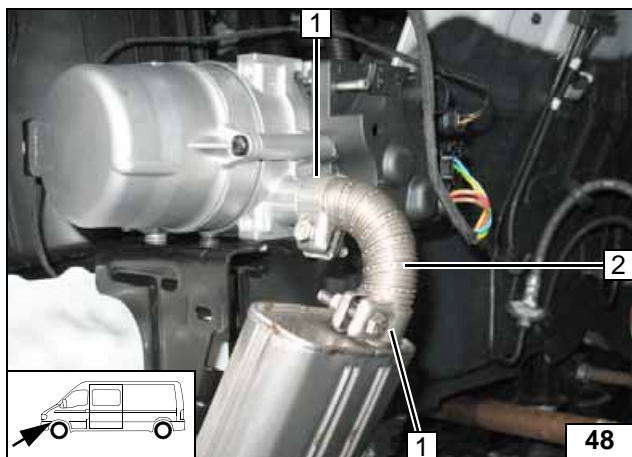
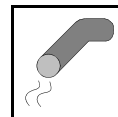

- 1 Hose clamp [2x]
- 2 Exhaust pipe

Installing
exhaust
pipe

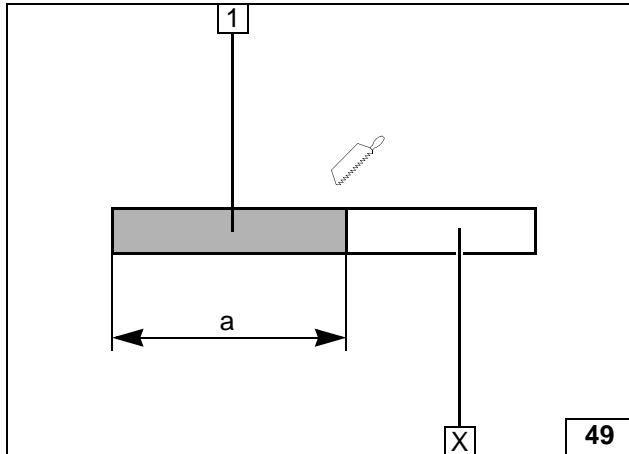
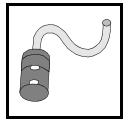

Combustion Air

Discard section X.

- 1 Combustion air pipe
a = 350



Cutting combustion air pipe to length

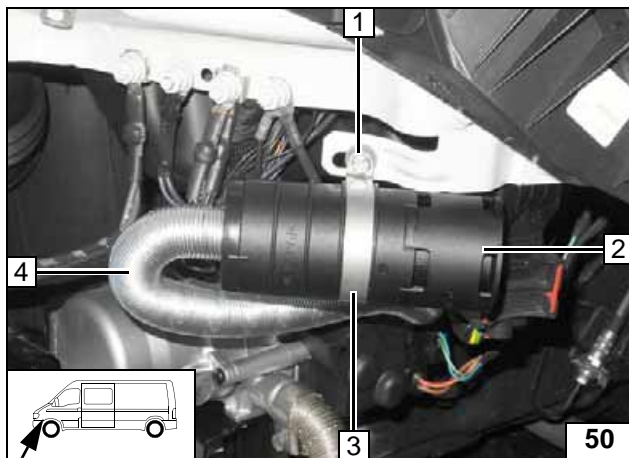

- 1 M5x16 bolt, large diameter washer, flanged nut, existing hole
- 2 Silencer
- 3 51mm dia. clamp
- 4 Combustion air pipe



Mounting silencer

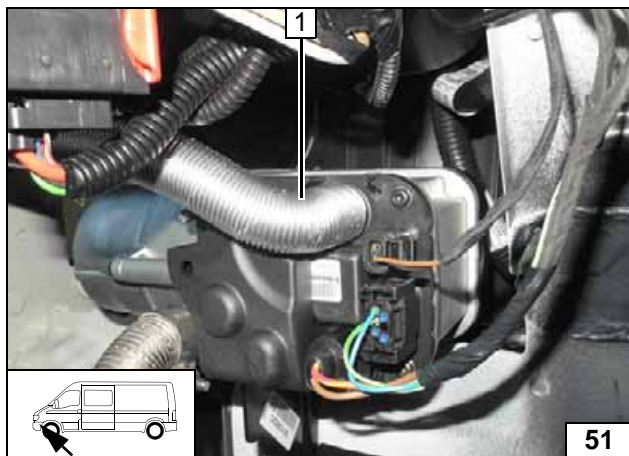

- 1 Combustion air pipe



Installing combustion air pipe



Coolant Circuit 2.0 D / 2.2 HDI / 2.3 D

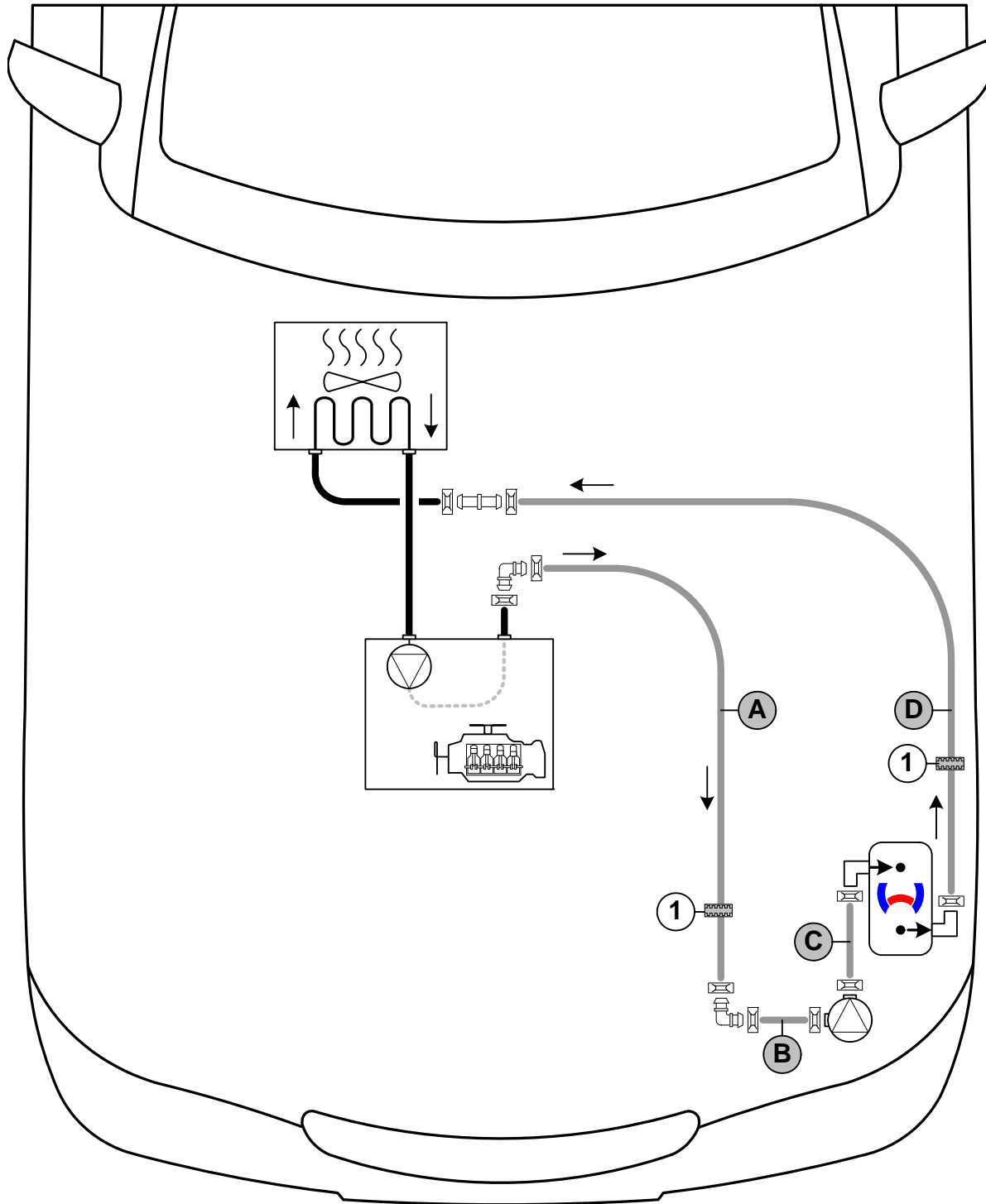

WARNING!

Any coolant running off should be collected in an appropriate container. Route hoses so that they are kink-free. Unless specified otherwise, always fasten using cable ties. Position clamps so that other hoses cannot be damaged. When installing the hoses, the heater must be filled with coolant. The connection should be modelled on an "inline" circuit and based on the following diagram:



Hose routing diagram

All spring clips  = 25 mm dia.

1 = Black (sw) rubber isolator . All connecting pipes  and  = 18x18mm dia.







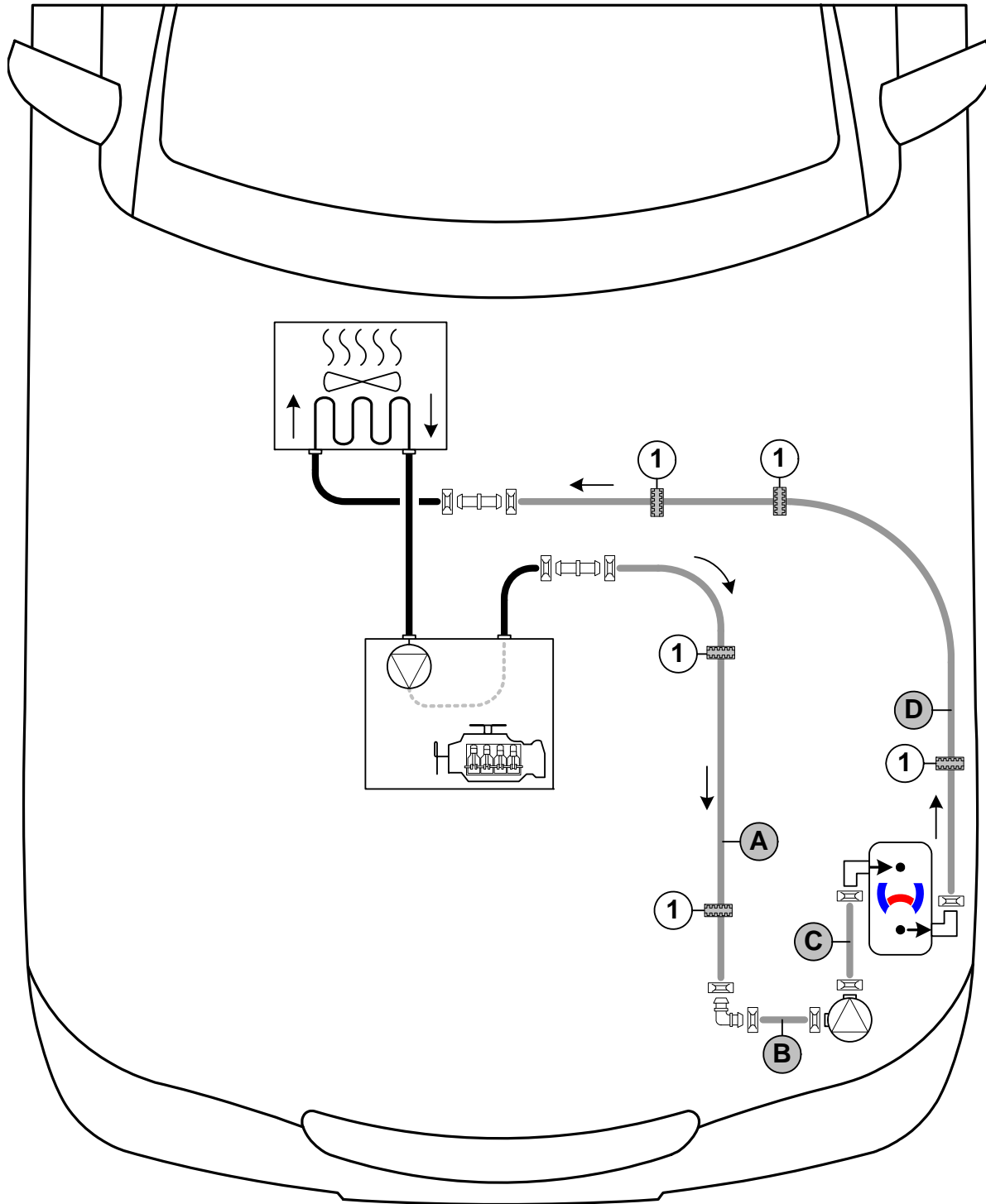

Coolant Circuit 3.0 D

WARNING!

Any coolant running off should be collected in an appropriate container. Route hoses so that they are kink-free. Unless specified otherwise, always fasten using cable ties. Position clamps so that other hoses cannot be damaged. When installing the hoses, the heater must be filled with coolant. The connection should be modelled on an "inline" circuit and based on the following diagram:



Hose routing diagram

All spring clips  = 25 mm dia.
 1 = Black (sw) rubber isolator .
 All connecting pipes  and  = 18x18mm dia.



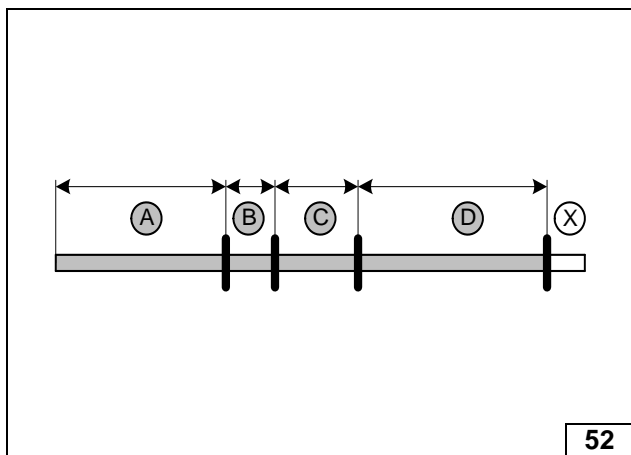

All vehicles

Discard section **X**.
Hoses **A** and **D** are not cut to length accordingly until installation.

	2.0 / 2.3 D	2.2 HDI	3.0 D
A =	710	560	1010
B =	80	80	80
C =	130	130	130
D =	750	480	830

Cutting hoses to length

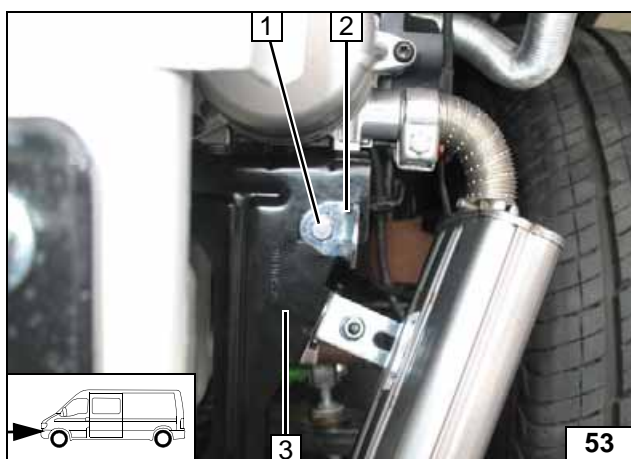

- 1 M6x20 bolt, flanged nut, existing hole
- 2 Angle bracket
- 3 Bracket

Installing angle bracket

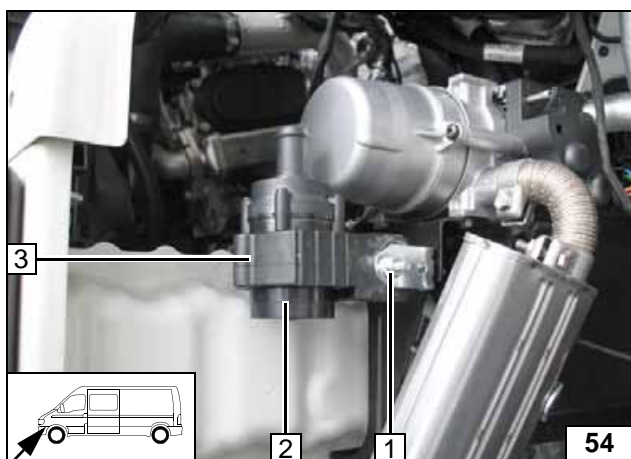

- 1 M6x25 bolt, large diameter washer with outer dia. $d_a = 17.6\text{mm}$; flanged nut
- 2 Circulating pump
- 3 Circulating pump mounting

Mounting circulating pump



- 1 Connector of circulating pump wiring harness

Mounting wiring harness

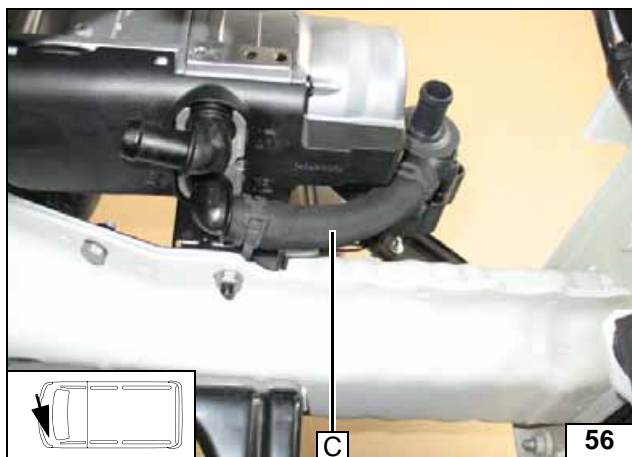

Air filter housing only removed for documentary purposes.



**Connect-
ing heater
inlet**

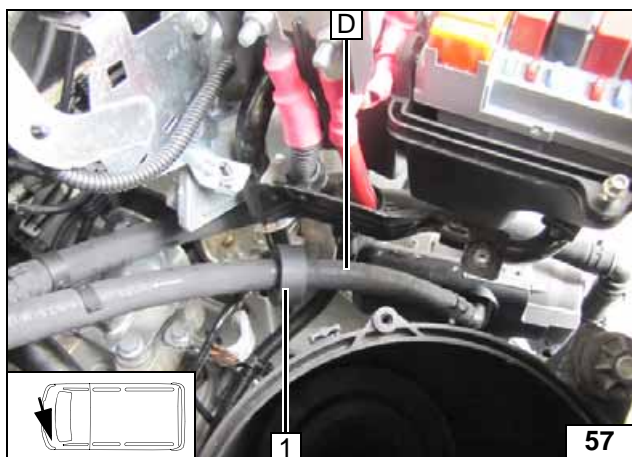

1 Rubber isolator

**Connection
/ routing**

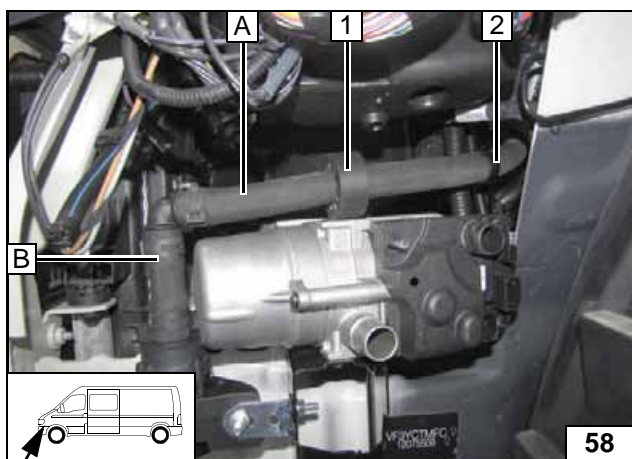

Route hose **A** to the cutting point!

- 1 Rubber isolator
- 2 Hose bracket (between hose **A** and original vehicle wiring harness)



**Connection
/ routing**

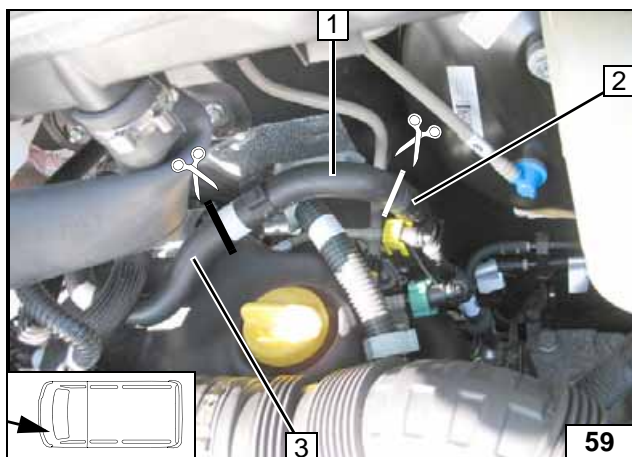

2.0 D

Cut hose on engine outlet / heat exchanger inlet at the marking. Discard hose section 1.

- 2 Hose section of engine outlet
- 3 Hose section of heat exchanger inlet



**Cutting
point**

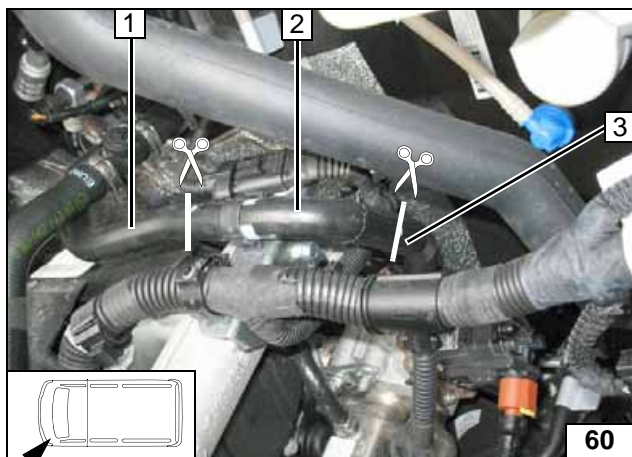

2.3 D

Cut hose on engine outlet / heat exchanger inlet at the marking. Remove braided protection hose (if present) at position 3. Discard hose section 2.

- 1 Hose section of heat exchanger inlet
- 3 Hose section of engine outlet



Cutting point

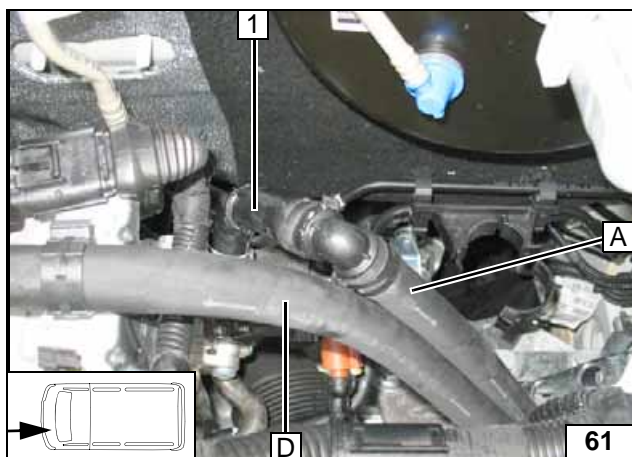

2.0 and 2.3 D

The next three images show the connection of hoses **A** and **D** for the 130 Multijet. Cut hose **A** to length and connect with engine outlet hose 1!



Connecting engine outlet

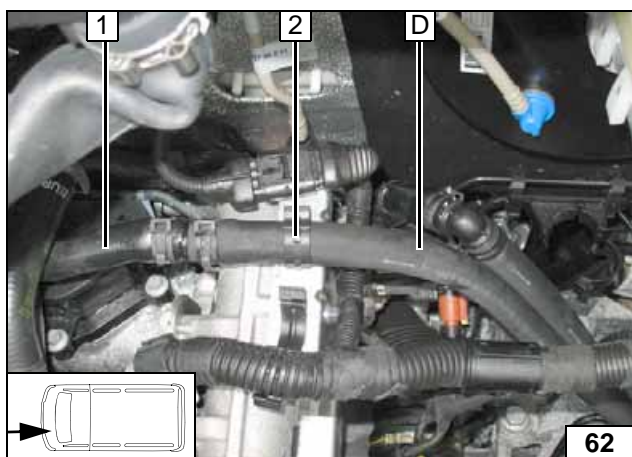

Cut hose **D** to length and connect with heat exchanger inlet hose 1!

- 2 Original vehicle hose bracket



Connecting heat exchanger inlet

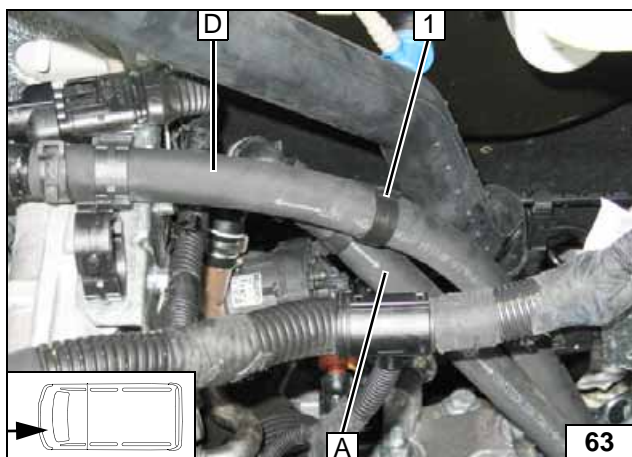

Align hoses. Ensure sufficient distance to neighbouring components; correct if necessary.

- 1 Hose bracket (between hoses **A** and **D**)



Inserting hose bracket

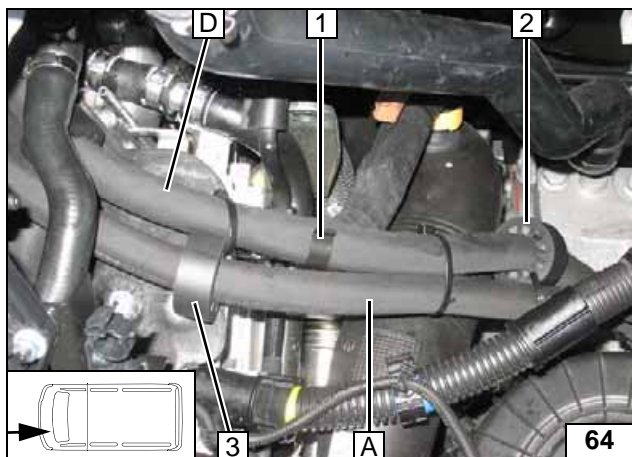

3.0 D

Slide black (sw) rubber isolator **2** onto hose **D**.
Slide black (sw) rubber isolator **3** onto hose **A**.

- 1 Install hose bracket (between hose **D** and original vehicle wiring harness)

Routing in engine compartment

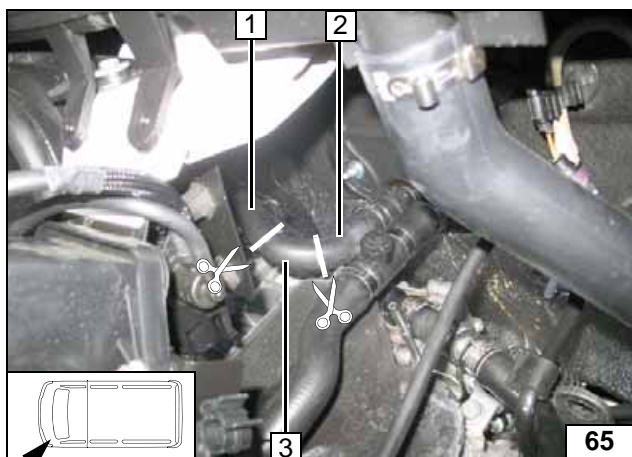

Cut hose on engine outlet / heat exchanger inlet at the marking.

- 1 Hose section of heat exchanger inlet
- 2 Hose section of engine outlet
- 3 Discard hose section

Cutting point

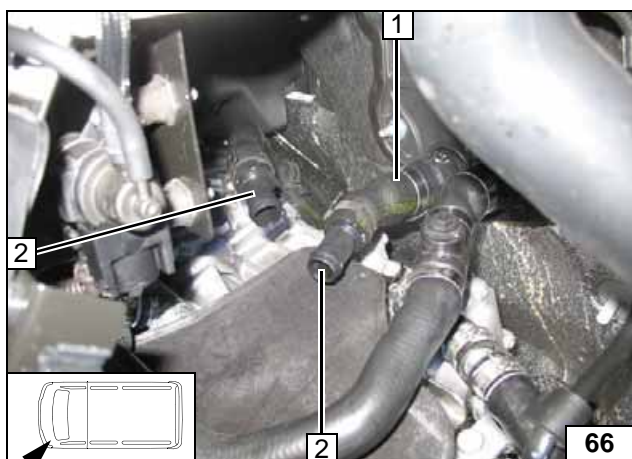

Hose section of heat exchanger inlet **1** twisted to the left on the connection piece.

- 2 18x18mm dia. connecting pipes

Premounting connecting pipes

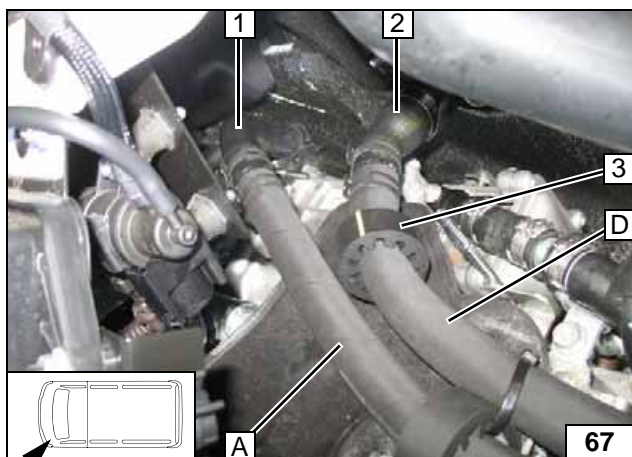

Slide black (sw) rubber isolator **3** onto hose **D**!

- 1 Hose of engine outlet
- 2 Hose of heat exchanger inlet

Connecting engine outlet and heat exchanger inlet



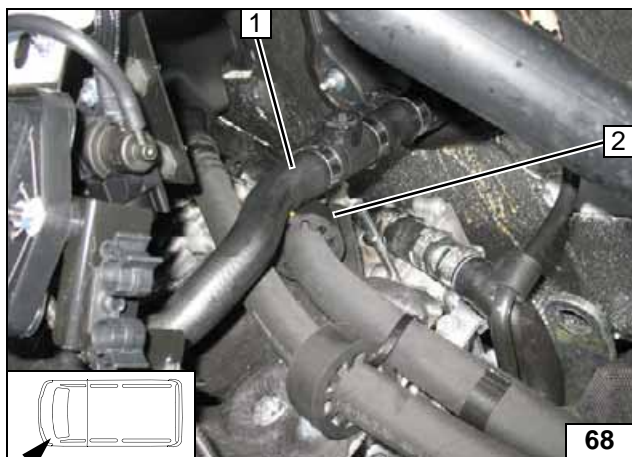

- 1 Hose of heat exchanger outlet
- 2 Black (sw) rubber isolator

Aligning rubber isolator

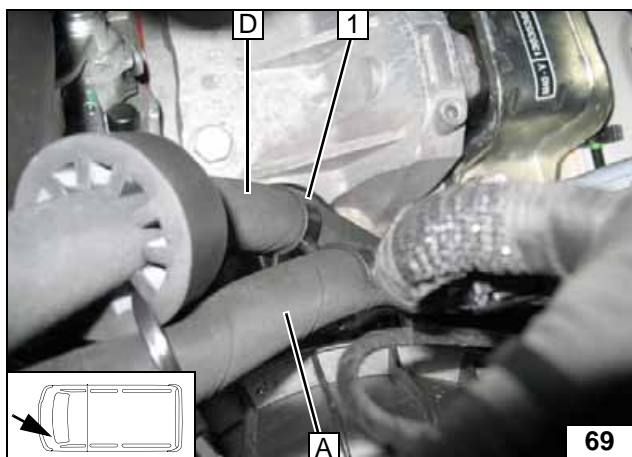

Align hoses. Ensure sufficient distance to neighbouring components; correct if necessary.

- 1 Hose bracket (between hoses A and D)

Mounting hose bracket

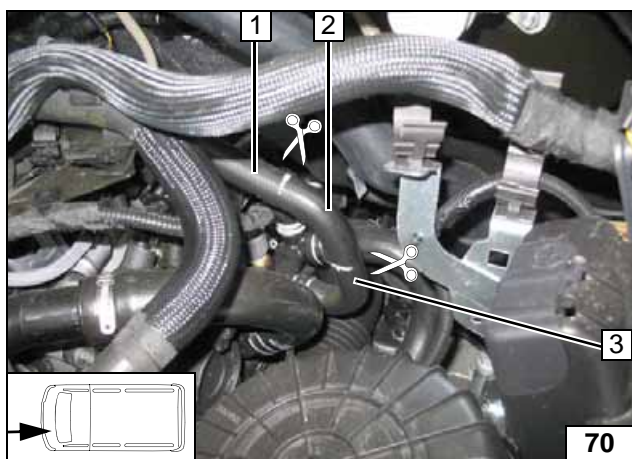

2.2 HDI

Cut hose on engine outlet / heat exchanger inlet at the marking.

- 1 Hose section of heat exchanger inlet
- 2 Discard hose section
- 3 Hose section of engine outlet

Cutting point

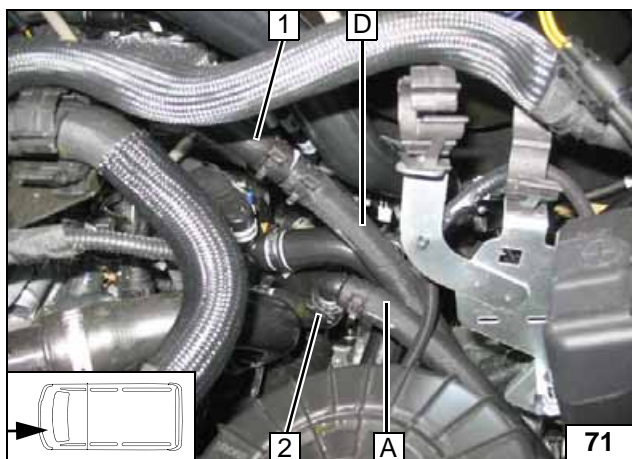

- 1 Hose section of heat exchanger inlet
- 2 Hose section of engine outlet

Connecting heat exchanger inlet and engine outlet

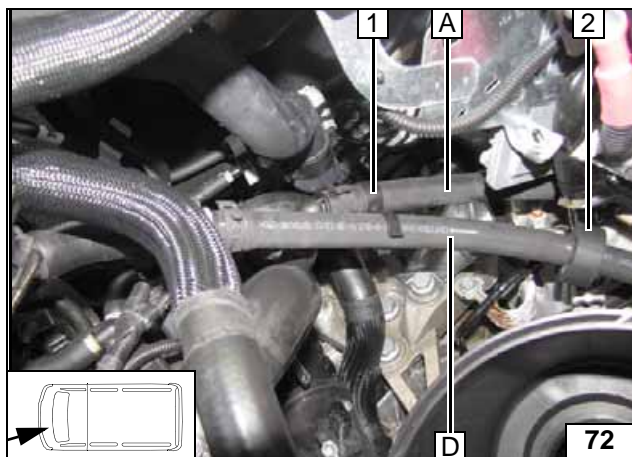

Align hoses. Ensure sufficient distance to neighbouring components; correct if necessary.

- 1 Hose bracket (between hoses **A** and **D**)
- 2 Align black (sw) rubber isolator



**Mounting
hose
bracket**



Fuel

CAUTION!

Open the vehicle's fuel tank cap, ventilate the tank and then re-close the tank lock.

Catch any fuel running off in an appropriate container.

Route fuel line and metering pump wiring harness so that they are protected against stone impact. Unless specified otherwise, always fasten using cable ties.

Provide rub protection for fuel line and wiring harness in areas where there are sharp edges.

WARNING!

The fuel line and wiring harness are routed to the metering pump as shown in the wiring harness routing diagram.

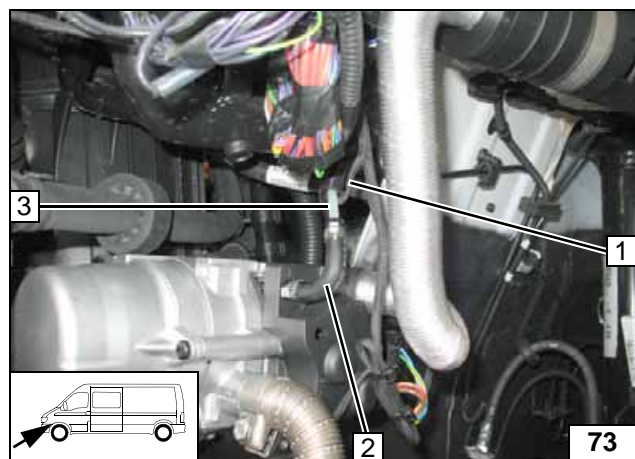

Pull fuel line **3** and wiring harness of metering pump **1** into 10mm dia. corrugated tube.

- 2 90° moulded hose, 10mm dia. clamp [2x]



**Connect-
ing heater**

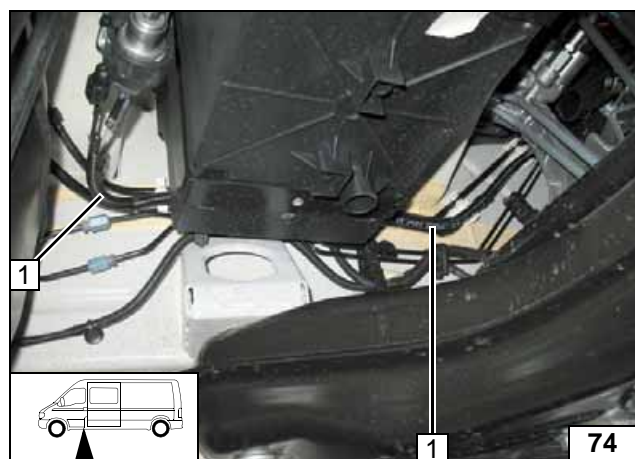

Route fuel line and wiring harness of metering pump in 10mm dia. corrugated tube **1** along original vehicle fuel lines to installation location of metering pump.



**Routing
lines**

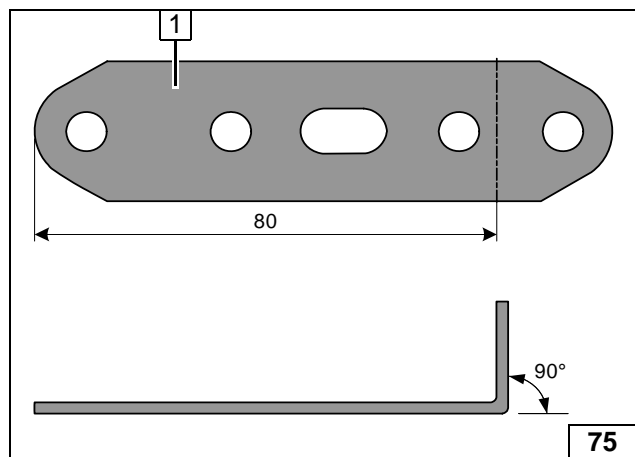

- 1 Perforated bracket



**Angling
down per-
forated
bracket**

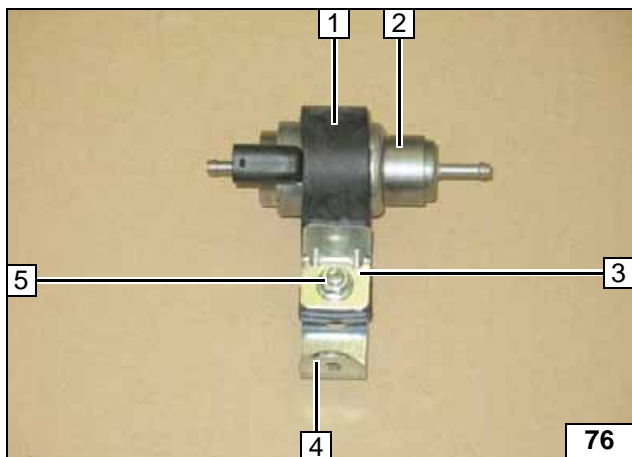

- 1 Mounting of metering pump
- 2 Metering pump
- 3 Support angle bracket
- 4 Perforated bracket
- 5 M6x25 bolt, flanged nut

Premounting metering pump

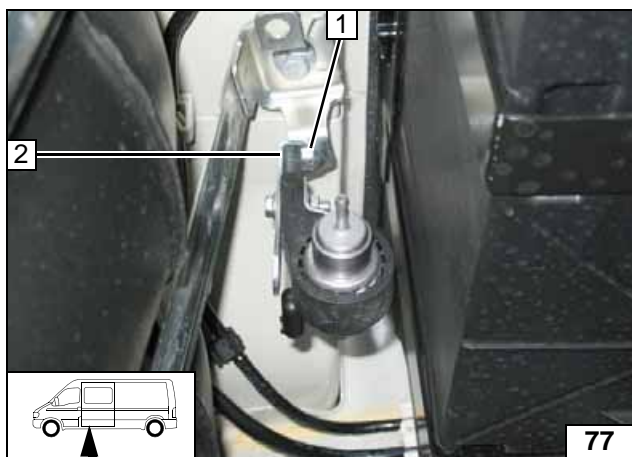

- 1 M6x20 bolt, large diameter washer, flanged nut on existing hole
- 2 Perforated bracket



Mounting metering pump

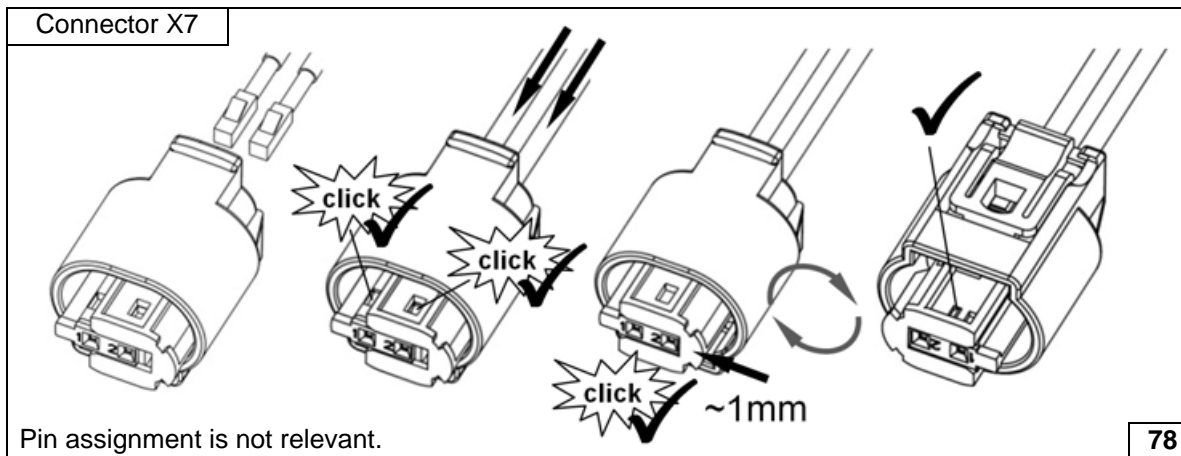

Completing connector of metering pump

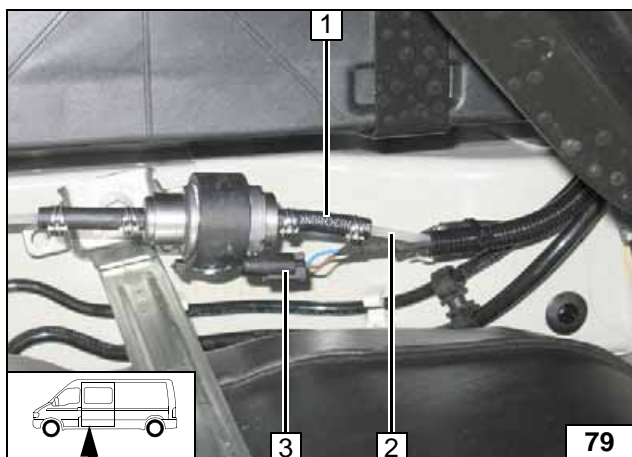

- 1 Hose section, 10mm dia.clamp [2x]
- 2 Fuel line of heater
- 3 Wiring harness of metering pump, connector X7 mounted



Connecting metering pump

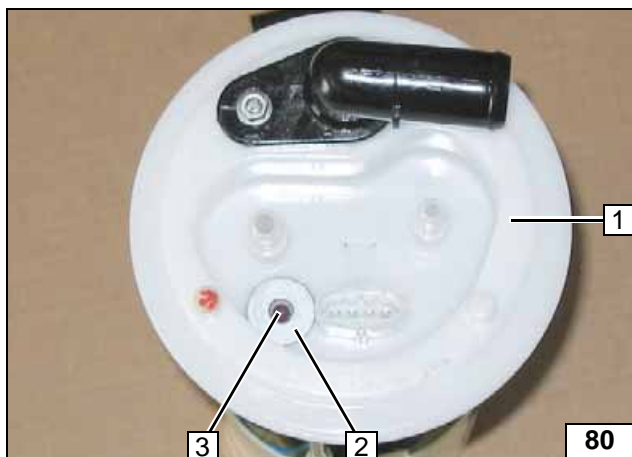

Remove fuel-tank sending unit **1** in accordance with the manufacturer's instructions.

- 2** Large diameter washer with outer dia. $d_a = 21.6\text{mm}$
- 3** Copy hole pattern, 6mm dia. hole



Fuel extraction

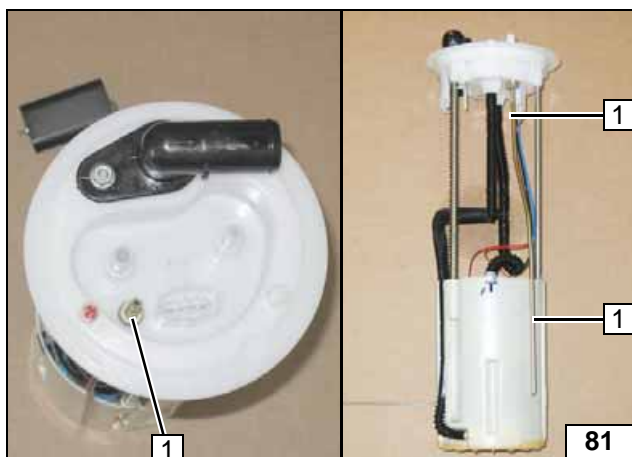

Shape fuel standpipe **1** according to template and cut it to length.



Installing fuel standpipe

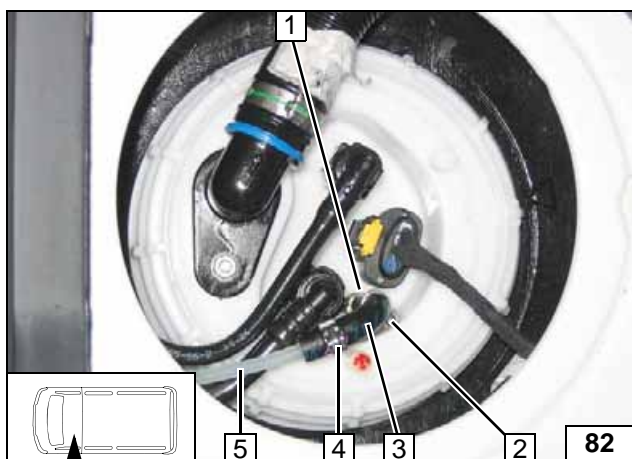

Install fuel-tank sending unit according to manufacturer's instructions.

- 1** Fuel standpipe
- 2** 9mm dia. clamp
- 3** 90°, 3.5 x 4.5 mm dia. moulded hose
- 4** 10mm dia. clamp
- 5** Fuel line



Connecting fuel line

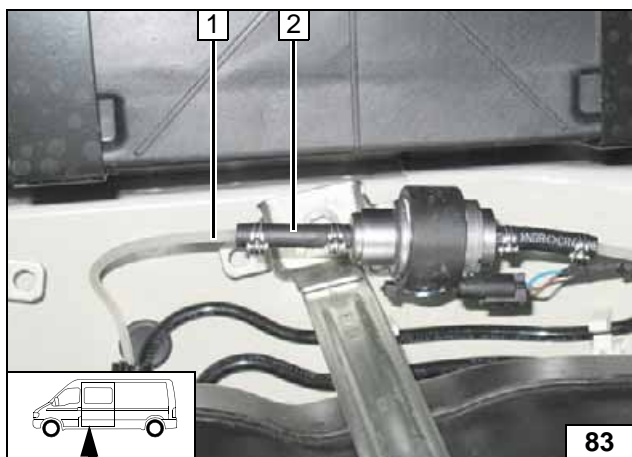

Ensure sufficient distance to neighbouring components; correct if necessary.

- 1** Fuel line of fuel standpipe
- 2** Hose section, 10mm dia.clamp [2x]



Connecting metering pump

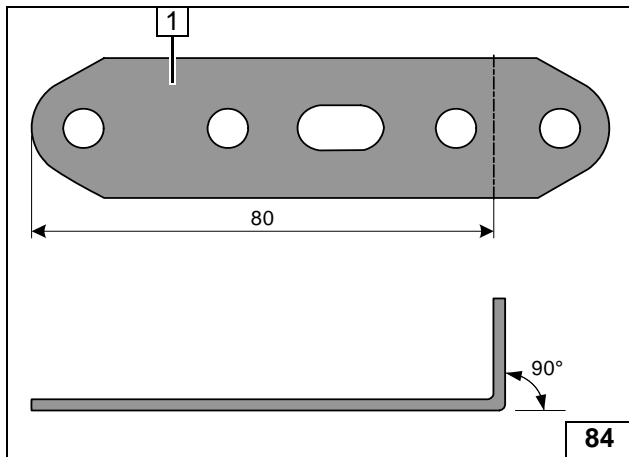

Exhaust Gas Part 2

- 1 Perforated bracket



Angling down perforated bracket

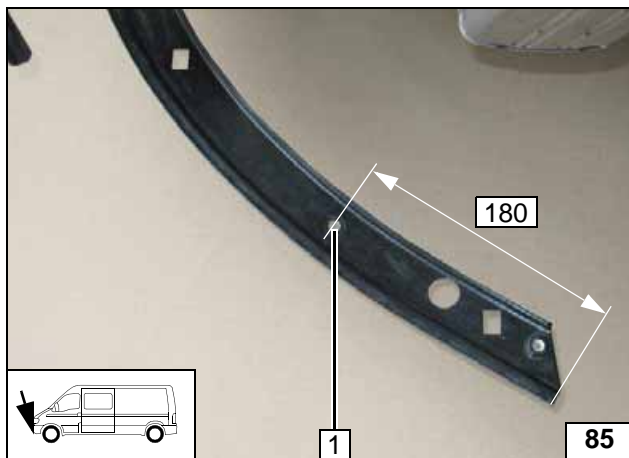

- 1 7 mm dia. hole

Hole in cross member

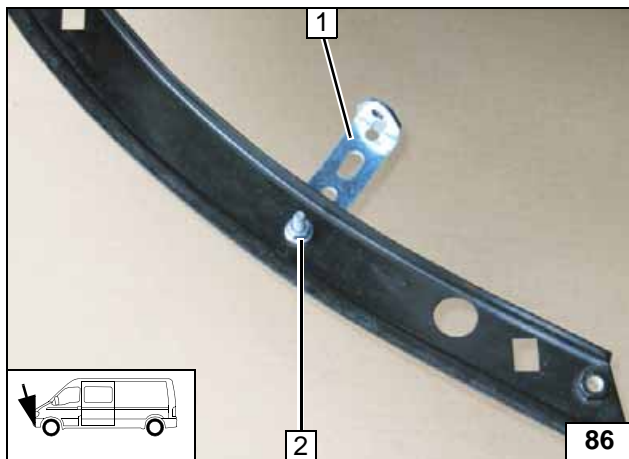

- 1 Perforated bracket
- 2 M6x20 bolt, flanged nut

Installing perforated bracket

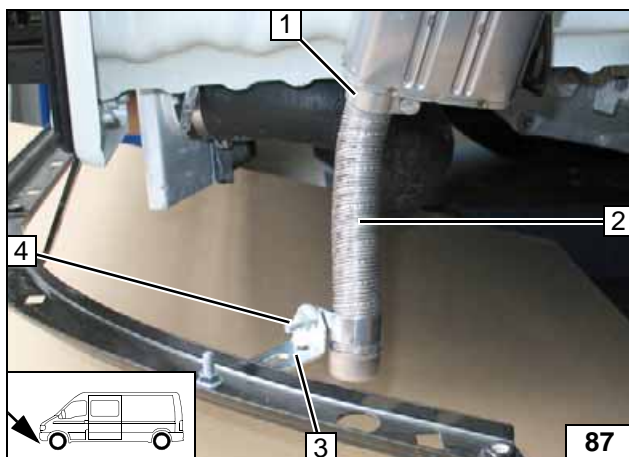

Ensure sufficient distance to neighbouring components; correct if necessary.

- 1 Hose clamp
- 2 Exhaust end section
- 3 Perforated bracket
- 4 M6x20 bolt, p-clamp, flanged nut



Installing exhaust end section



Final Work

WARNING!

Mount removed parts in reverse order. Check all hoses, clamps and all electrical connections for firm seating. Insulate all loose wires and tie back.

Only use manufacturer-approved coolant. Spray the heater components with anti-corrosion wax (Tectyl 100K, Order No. 111329).



- **Connect the battery.**
- **Fill and bleed the coolant circuit according to the vehicle manufacturer's specifications.**
- **Adjust MultiControl CAR, teach telestart transmitter.**
- **Make settings on A/C control panel according to the "Operating Instructions for End Customer".**
- **Place the "Switch off parking heater before refuelling" caution label in the area of the filler neck.**
- **For initial startup and function check, please see installation instructions.**



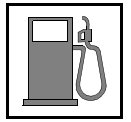

Template for Fuel Standpipe

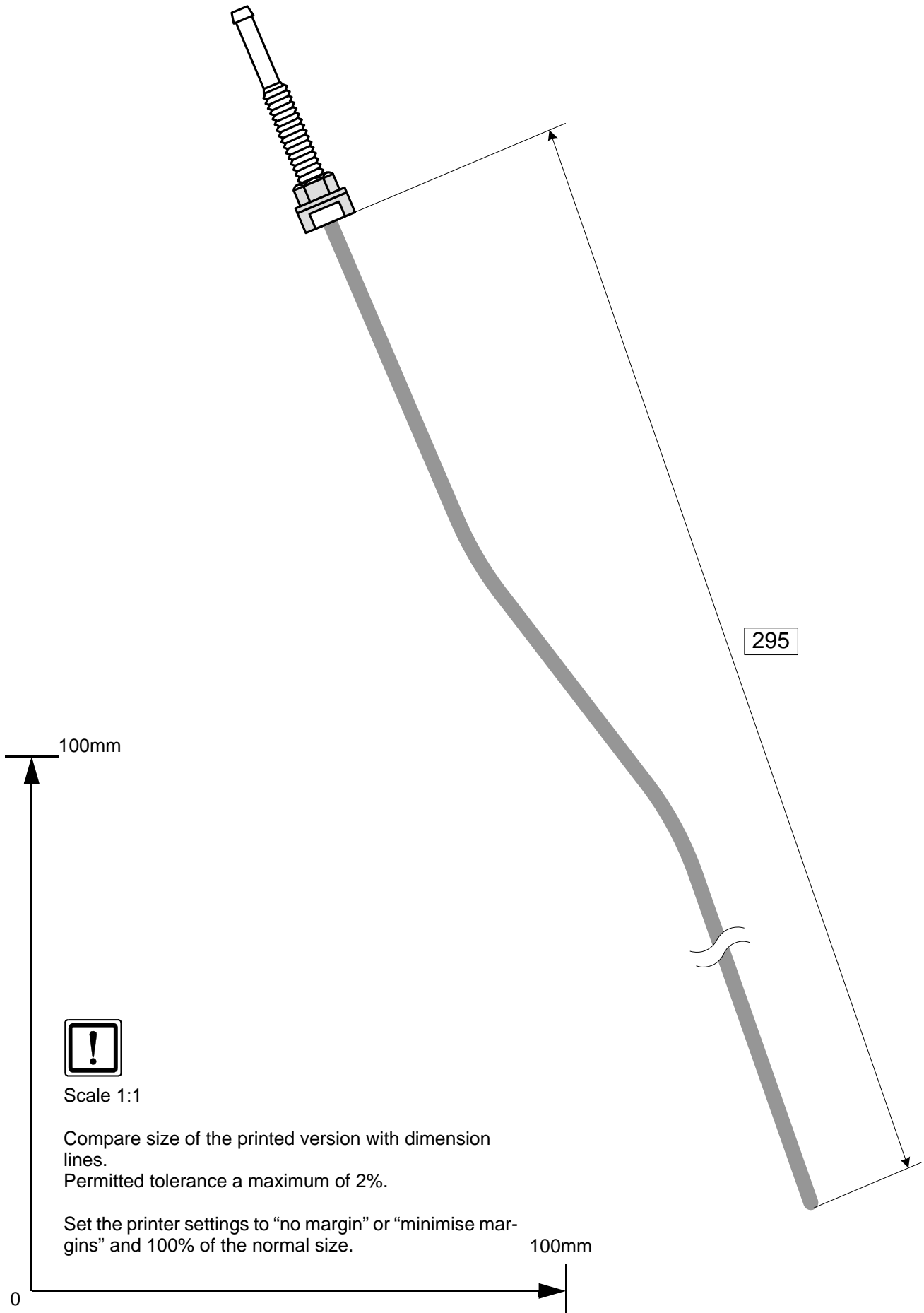



Template for Bracket

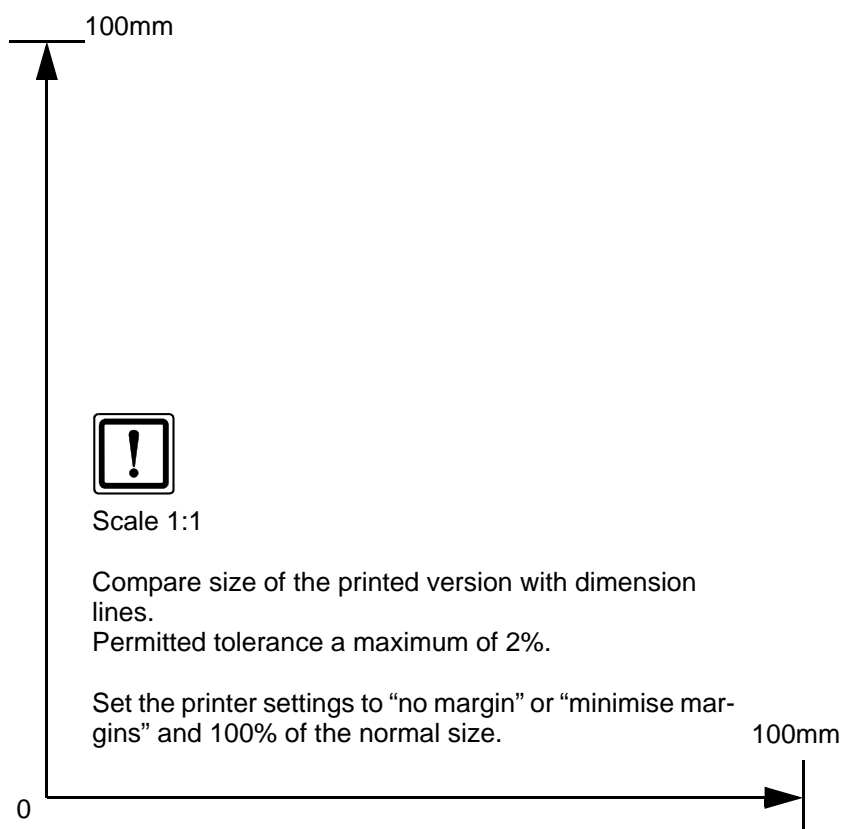
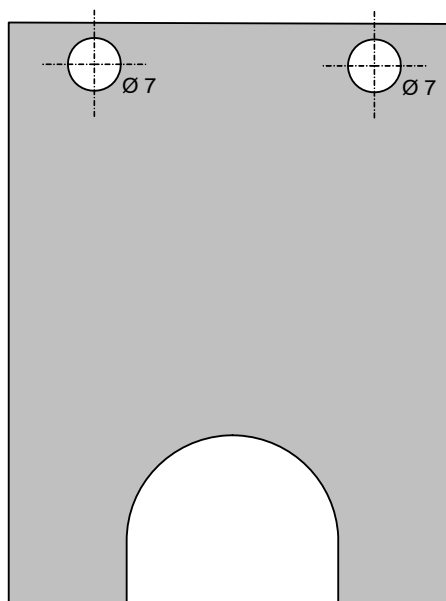

Operating Instructions for Manual Air-Conditioning

Please remove page and add to the vehicle operating instructions.

Note:

We recommend matching the heating time to the driving time.

Heating time = driving time

Example:

For a driving time of approx. 20 min. (in one direction), we recommend not exceeding a switch-on time of 20 min.

Passenger compartment monitoring, if installed, must be deactivated in addition to the vehicle settings for the heating operation.

For instructions on deactivation, please refer to the operating instructions of the vehicle.

Before parking the vehicle, make the following settings:

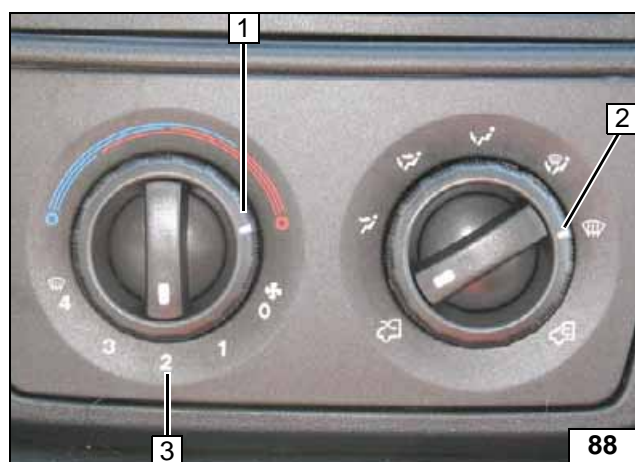

- 1 Set temperature to "max."
- 2 Air outlet onto windscreen
- 3 Set fan to level "1", or possibly "2"

A/C control panel

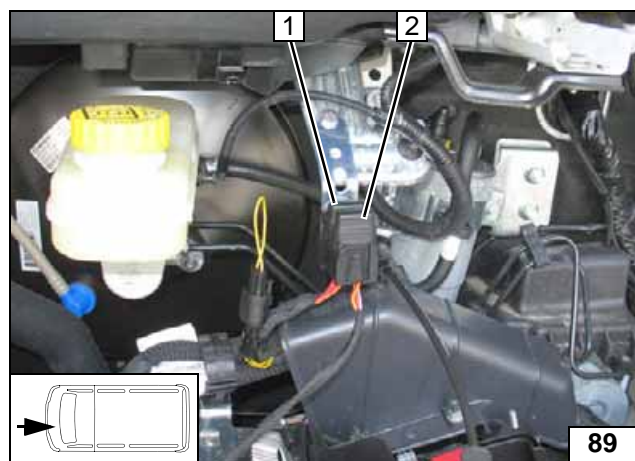

- 1 30A passenger compartment main fuse F2
- 2 20A heater fuse F1

Fuses of engine compartment



- 1 1A fuse of heater control F3
- 2 25A fan fuse F4

Fuses of passenger compartment



Operating Instructions Automatic Air-Conditioning

Please remove page and add to the vehicle operating instructions.

Note:

We recommend matching the heating time to the driving time.

Heating time = driving time

Example:

For a driving time of approx. 20 min. (in one direction), we recommend not exceeding a switch-on time of 20 min.

Passenger compartment monitoring, if installed, must be deactivated in addition to the vehicle settings for the heating operation.

For instructions on deactivation, please refer to the operating instructions of the vehicle.

Before parking the vehicle, make the following settings:



- 1 Air outlet onto windscreen
- 2 Set temperature to "HI"

A/C control panel

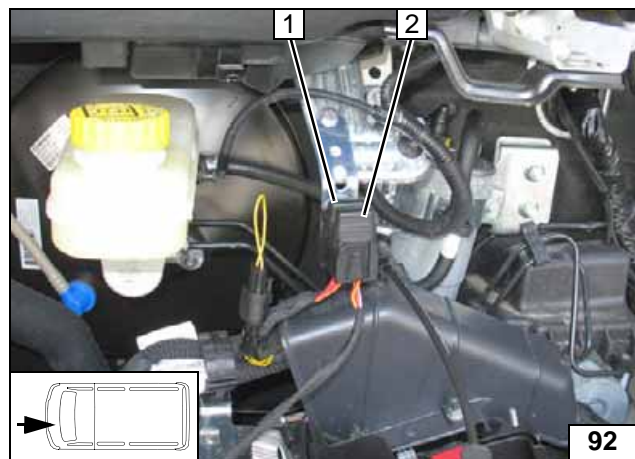

- 1 30A passenger compartment main fuse F2
- 2 20A heater fuse F1

Fuses of engine compartment



- 1 1A fuse of heater control F3
- 2 25A fan fuse F4

Fuses of passenger compartment

