

Water Heater

Thermo Top Evo Parking Heater

 00 0258

Installation Documentation Subaru XV / Forester



Validity

Manufacturer	Model	Type	Model Year	EG BE No. / ABE
Subaru	XV	G4	From model year 2012	e1 * 2007 / 46 * 0597 * ...
Subaru	Forester	SJ	From model year 2013 up to 2014	e13 * 2007 / 46 * 1305 * ...

Motorisation	Fuel	Transmission type	Output in kW	Displacement in cm ³	Engine code
2.0	Diesel	6-speed SG	108	1998	EE20

SG = manual transmission

Left-hand drive vehicle

Verified equipment variants: 1 and 2 zone automatic air-conditioning
 Front fog lights
 Keyless access
 4WD
 Headlight washer system with / without Xenon
 Rear level regulation
 Euro 5 emission standard
 Euro 6 emission standard (XV only)

Not verified: Stop & Go automatic choke

Total installation time: about 8 hours

Table of Contents

Validity	1	Preparing Installation Location	15
Necessary Components	2	Preparing Heater	17
Installation Overview	2	Installing Heater	20
Information on Total Installation Time	2	Combustion Air	21
Information on Operating and Installation Instructions	3	Fuel	22
Information on Validity	4	Coolant Circuit	28
Technical Information	4	Exhaust for Vehicles with Euro 5 Emission Standard	33
Explanatory Notes on Document	4	Exhaust for Vehicles with Euro 6 Emission Standard	35
Preliminary Work	5	Final Work	37
Heater Installation Location	5	Template for Fuel Standpipe Version 1	38
Preparing Electrical System	6	Template for Fuel Standpipe Version 2	39
Electrical System	8	Operating Instructions for 1-Zone Automatic Air-Conditioning	40
Fan Controller	9	Operating Instructions for 2-Zone Automatic Air-Conditioning	41
A/C Control Panel Installation Aid	10		
MultiControl CAR Option	13		
Remote Option (Telestart)	13		
ThermoCall Option	14		

Necessary Components

- Basic delivery scope of Thermo Top Evo based on price list
Subaru part number: **1166**
- Installation kit Subaru XV 2012 / Forester 2013 Diesel: **1318549B**
Subaru Kit number: **1166-01**
- In case of Telestart, heater control as well as indicator lamp in accordance with price list and in consultation with end customer
- In case of MultiControl CAR installation: MultiControl installation frame: **9030077_**
Subaru part number: **9965-27**

Installation instructions:

- Arrange for the vehicle to be delivered with the tank only about ¼ full.
- The installation location of the push button in case of Telestart or ThermoCall should be confirmed with the end customer.
- Depending on the space required and the vehicle manufacturer's instructions, we recommend the use of a vehicle battery with a higher electrical capacity.

Installation Overview

Legend:

1. Heater
2. Engine compartment fuse holder
3. Passenger compartment relay and fuse holder
4. Circulating pump
5. MultiControl CAR
6. Metering pump

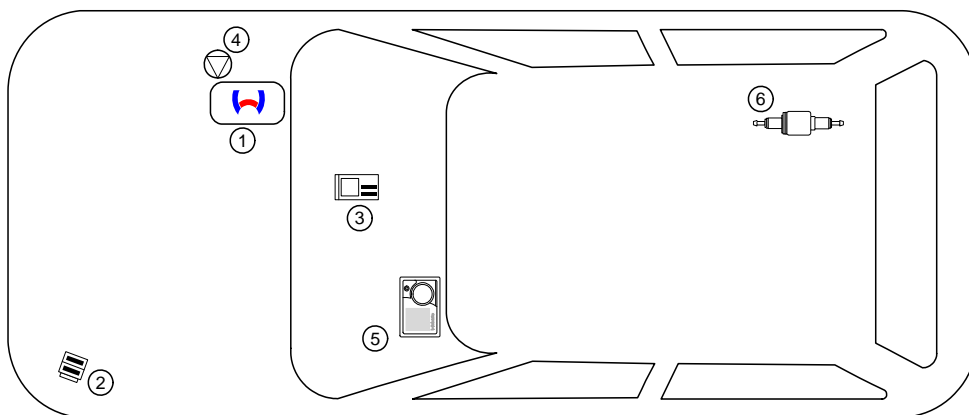

Information on Total Installation Time

The total installation time includes the time needed for mounting and demounting the vehicle-specific components, the heater specific installation time and all other times required for the system integration and initial start-up of the heater.

The total installation time may vary for vehicle equipment other than provided.

Information on Operating and Installation Instructions

1 Important information (not complete)

1.1 Installation and repair



The improper installation or repair of Webasto heating and cooling systems can cause fire or the leakage of deadly carbon monoxide, leading to serious injury or death.



To install and repair Webasto heating and cooling systems you need to have completed a special company training course and have the appropriate technical documentation, special tools and special equipment.



Installation and repair may ONLY be carried out by persons trained and certified in a Webasto training course. NEVER try to install or repair Webasto heating or cooling systems if you have not completed a Webasto training course, you do not have the necessary technical skills and you do not have the technical documentation, tools and equipment available to ensure that you can complete the installation and repair work properly.

Only use genuine Webasto parts. See the Webasto air and water heaters accessories catalogue for this purpose.

1.2 Operation

To ensure safe operation, we recommend having the heater checked every two years by an authorised Webasto dealer, especially when used over a long period and/or under extreme environmental conditions.

Do not operate the heater in closed rooms due to the danger of poisoning and suffocation.

Always switch off the heater before refuelling.

The heater may only be used with the prescribed fuel diesel (DIN EN 590) or petrol (DIN EN 228).

The heater may not be cleaned with a high-pressure cleaner.

1.3 Please note

ALWAYS follow all Webasto installation and operating instructions and observe all warnings.

To become familiar with and understand all functions and properties of the heater, the operating instructions must be read carefully and observed at all times.

For proper, safe installation and repair work, the installation instructions with all warnings and safety information must be carefully read and observed at all times. Please always contact a workshop authorised by Webasto for all installation and repair work.

Important

Webasto shall assume no liability for defects, damage and injuries resulting from a failure to observe the installation, repair and operating instructions of the information contained in them.

This liability exclusion particularly applies to improper installations and repairs, installations and repairs by untrained persons or in the case of a failure to use genuine spare parts.

The liability due to culpable disregard to life, limb or health and due to damage or injuries caused by a wilful or reckless breach of duty remain unaffected, as does the obligatory product liability.

Installation should be carried out according to the general, standard rules of technology. Unless specified otherwise, fasten hoses, lines and wiring harnesses to original vehicle lines and wiring harnesses using cable ties. Insulate loose wire ends and tie back. Connectors on electronic components must audibly snap into place during assembly.

Sharp edges should be fitted with rub protection. Spray unfinished body areas, e.g. drilled holes, with anti-corrosion wax (Tectyl 100K).

Observe the instructions and guidelines of the respective vehicle manufacturer for demounting and mounting vehicle specific components!

The initial startup is to be executed with the Webasto Thermo Test Diagnosis.

When installing a programmable control module (e.g. a PWM Gateway), the corresponding settings must be checked or adjusted.

2 Statutory regulations governing installation

Guidelines	Thermo Top Evo
Heating Directive ECE R122	E1 00 0258
EMC Directive ECE R10	E1 04 5627

Note

The regulations of these guidelines are binding in the scope of the Directive 70/156/EEC and/or 2007/46/EC (for new vehicle models from 29/04/2009) and should also be observed in countries in which there are no special regulations.

Important

Failure to follow the installation instructions will result in the invalidation of the type approval for the heater and therefore invalidation of the general **homologation of the vehicle**.

Note

The heater is licensed in accordance with paragraph 19, section 3, No. 2b of the StVZO (German Road Traffic Licensing Authority).

2.1 Excerpt from ECE regulation 122 (heating system) paragraph 5 for the installation of the heater

Beginning of excerpt.

ANNEX VII

REQUIREMENTS FOR COMBUSTION HEATERS AND THEIR INSTALLATION

1. GENERAL REQUIREMENTS

1.7.1. A clearly visible tell-tale in the operator's field of view shall inform when the combustion heater is switched on or off.

2. VEHICLE INSTALLATION REQUIREMENTS

2.1. Scope

2.1.1. Subject to paragraph 2.1.2. combustion heaters shall be installed according to the requirements of this Annex.

2.1.2. Vehicles of category O having liquid fuel heaters are deemed to comply with the requirements of this Annex.

2.2. Positioning of heater

2.2.1. Body sections and any other components in the vicinity of the heater must be protected from excessive heat and the possibility of fuel or oil contamination.

2.2.2. The combustion heater shall not constitute a risk of fire, even in the case of overheating. This requirement shall be deemed to be fulfilled if the installation ensures an adequate distance to all parts and suitable ventilation, by the use of fire resistant materials or by the use of heat shields.

2.2.3. In the case of M2 and M3 vehicles, the heater must not be positioned in the passenger compartment. However, an installation in an effectively sealed envelope which also complies with the conditions in paragraph 2.2.2 may be used.

2.2.4. The label referred to in paragraph 1.4 or a duplicate, must be positioned so that it can be easily read when the heater is installed in the vehicle.

2.2.5. Every reasonable precaution should be taken in positioning the heater to minimise the risk of injury and damage to personal property.

2.3. Fuel supply

2.3.1. The fuel filler must not be situated in the passenger compartment and must be provided with an effective cap to prevent fuel spillage.

2.3.2. In the case of liquid fuel heaters, where a supply separate to that of the vehicle is provided, the type of fuel and its filler point must be clearly labelled.

2.3.3. A notice, indicating that the heater must be shut down before refuelling, must be affixed to the fuelling point. In addition a suitable instruction must be included in the manufacturer's operating manual.

2.4. Exhaust system

2.4.1. The exhaust gas outlet must be located so as to prevent emissions from entering the vehicle through ventilators, heated air intakes or opening windows.

2.5. Combustion air inlet

2.5.1. The air for the combustion chamber of the heater must not be drawn from the passenger compartment of the vehicle.

2.5.2. The air inlet must be so positioned or guarded that blocking by rubbish or luggage is unlikely.

2.6. Heating air inlet

2.6.1. The heating air supply may be fresh or recirculated air and must be drawn from a clean area not likely to be contaminated by exhaust fumes emitted either by the propulsion engine, the combustion heater or any other vehicle source.

2.6.2. The inlet duct must be protected by mesh or other suitable means.

2.7. Heating air outlet

2.7.1. Any ducting used to route the hot air through the vehicle must be so positioned or protected that no injury or damage could be caused if it were to be touched.

2.7.2. The air outlet must be so positioned or guarded that blocking by rubbish or luggage is unlikely.

End of excerpt.

In multilingual versions the German language is binding.

Information on Validity

This installation documentation applies to Subaru XV diesel vehicles from model year 2012 and later as well as Subaru Forester vehicles from model year 2013 up to 2014 - for validity, see page 1 - , assuming technical modifications to the vehicle do not affect installation, any liability claims excluded. Depending on the vehicle version and equipment, modifications may be necessary during installation with respect to this 'installation documentation'.

Vehicle and engine types, equipment variants and other specifications not listed in this installation documentation have not been tested. However, installation according to this installation documentation may be possible.

Technical Information

Special Tools

- Hose clamp pliers for auto-tightening hose clamps
- Hose clamp pliers for Clic hose clamps of type W
- Automatic wire stripper, 0.2 - 6mm²
- Crimping pliers for cable lug / tab connector, 0.5 - 6mm²
- Torque wrench for 2.0 - 10 Nm
- Hose clamping pliers
- Metric thread-setter kit
- Deep-hole marker
- Webasto Thermo Test Diagnosis with current software

Dimensions

- All dimensions are in mm.















Tightening torque values

- Tightening torque values of 5x13 heater bolts and 5x11 heater stud bolts = 8Nm.
- Tightening torque value of 5x15 water connection piece retaining plate bolt = 7Nm.
- Tighten other bolt connections in accordance with manufacturer's instructions or in accordance with state-of-the-art-technology.

Explanatory Notes on Document

You will find an identification mark on the outside top right corner of the page in question to provide you with a quick overview of the individual working steps.

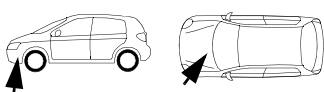
Special features are highlighted using the following symbols:

Mechanical System		Specific risk of injury or fatal accidents.	
Electrical System		Specific risk due to electrical voltage.	
Coolant Circuit		Specific risk of damage to components.	
Combustion Air		Specific risk of fire and explosion.	
Fuel		Reference to general installation instructions of the Webasto components or to the manufacturer's vehicle-specific documents.	
Exhaust Gas		Reference to a special technical feature.	
Software		The arrow in the vehicle icon indicates the position on the vehicle and the viewing angle.	
		Tightening torque according to the manufacturer's vehicle-specific documents.	

Subaru XV / Forester

Preliminary Work

Vehicle

- Open the fuel tank cap.
- Ventilate the fuel tank.
- Close the fuel tank cap again.
- Depressurise the cooling system.
- Disconnect the battery.
- Remove the engine cover.
- Remove the intercooler.
- Remove the wheel-well inner panel on the right.
- Remove the front and centre underride protection.
- Remove the rear underride protection on the right side.
- Remove the right front and rear door sill trims.
- Remove the glove box.
- Remove the A/C control panel in accordance with the manufacturer's instructions (see the dismantling instructions).
- Remove the lower instrument panel trim.
- Remove knee airbag and set aside.
- Remove the rear bench seat.
- Open the right-hand tank-fitting service lid.
- Remove the fuel tank sending unit in accordance with the manufacturer's instructions.

Heater

- Remove years that do not apply from the type and duplicate label.
- Attach the duplicate label (type label) visibly in the appropriate place in the engine compartment.

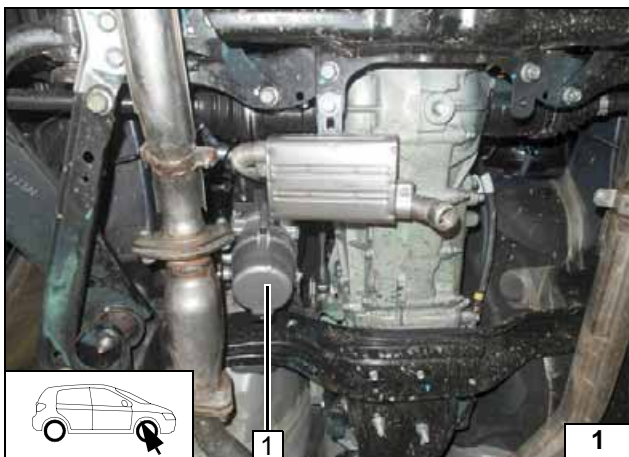

Heater Installation Location

Shown on a vehicle with Euro 6 emission standard!

- 1 Heater



Installation location

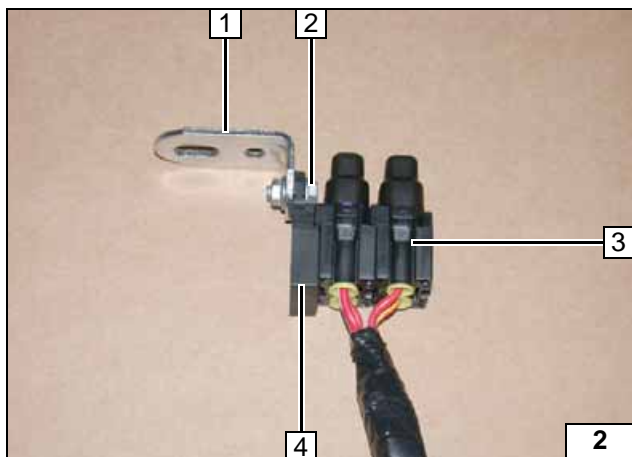

Preparing Electrical System

Wire sections retain their numbering in the entire document.

Produce all following electrical connections as shown in the wiring diagram.

- 1 Angle bracket
- 2 M5x16 bolt, washer [2x], nut
- 3 Fuses F1 - 2 mounted
- 4 Retaining plate of fuse holder



Preparing engine compartment fuse holder

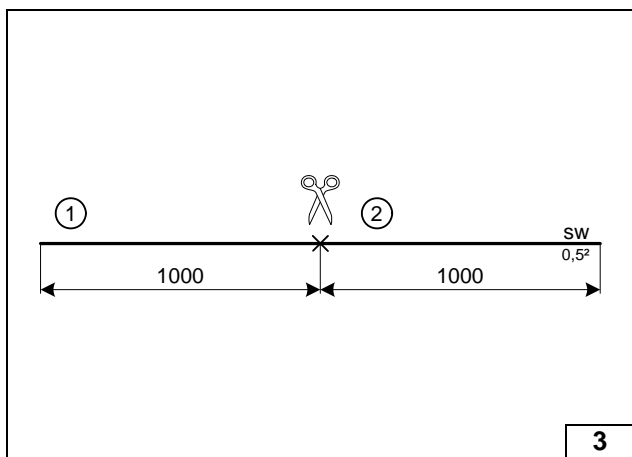

Pull wire sections ① and ② into one protective sleeving each.



Cutting to length / assigning wires

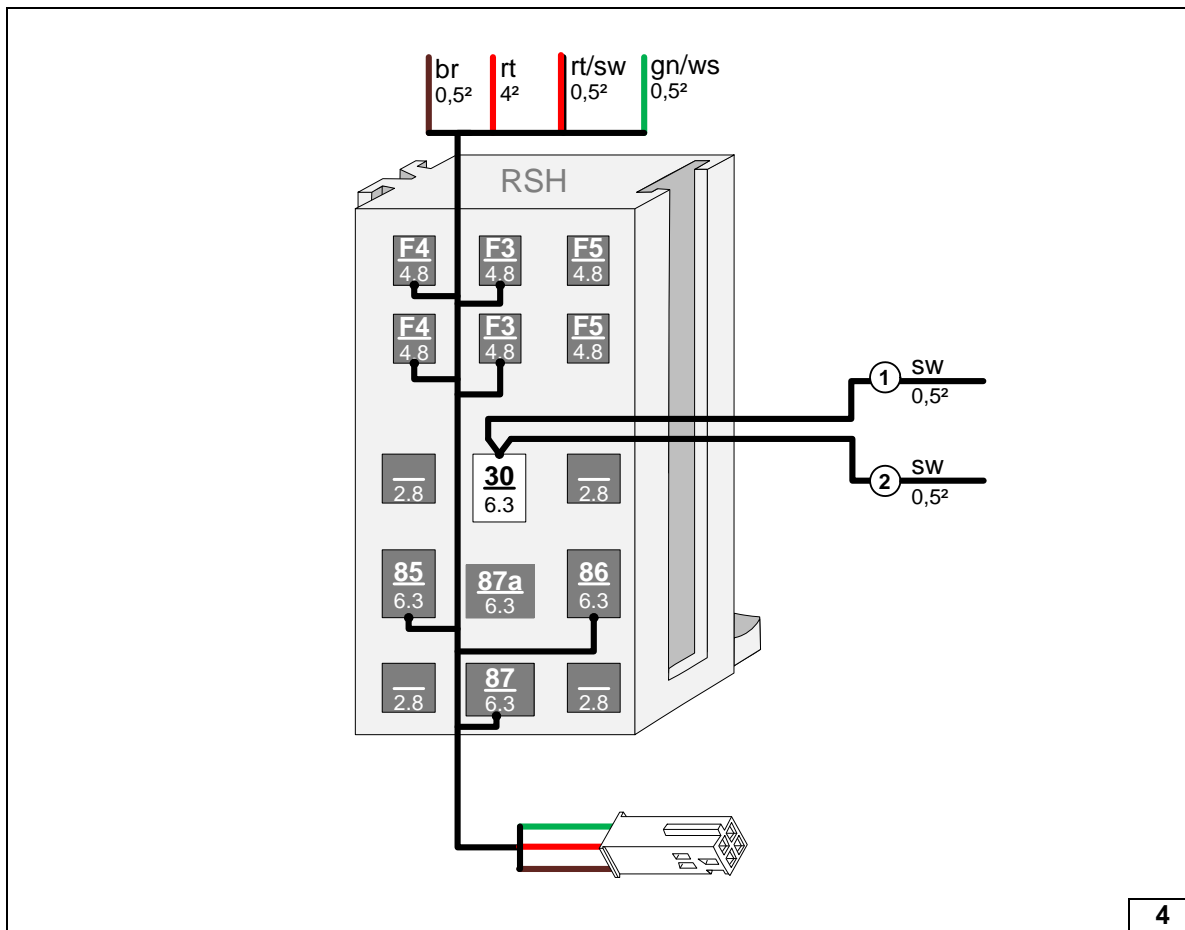

Connecting wires to passenger compartment relay and fuse holder

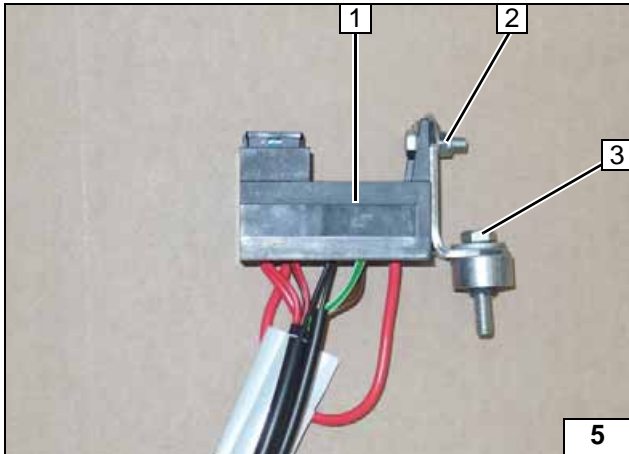

- 1 Passenger compartment relay and fuse holder
- 2 M5x16 bolt, washer, angle bracket, washer, nut
- 3 M6x25 bolt, washer, 10mm shim, pin lock

Preparing passenger compartment relay and fuse holder

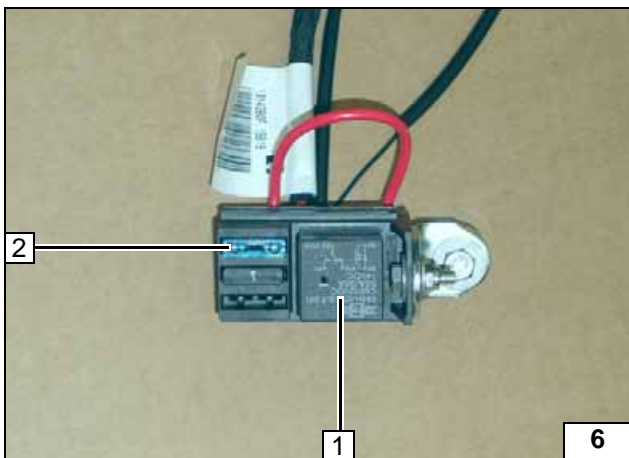

- 1 Relay K1
- 2 15A fuse F4

Inserting fuse F4 and relay K1

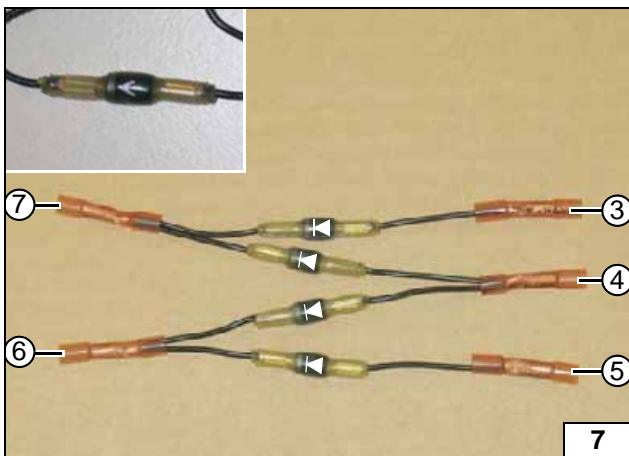

Premount four diodes with connectors to diode group D1 as shown. Watch direction of flow of diodes.



Premounting / assigning diode group

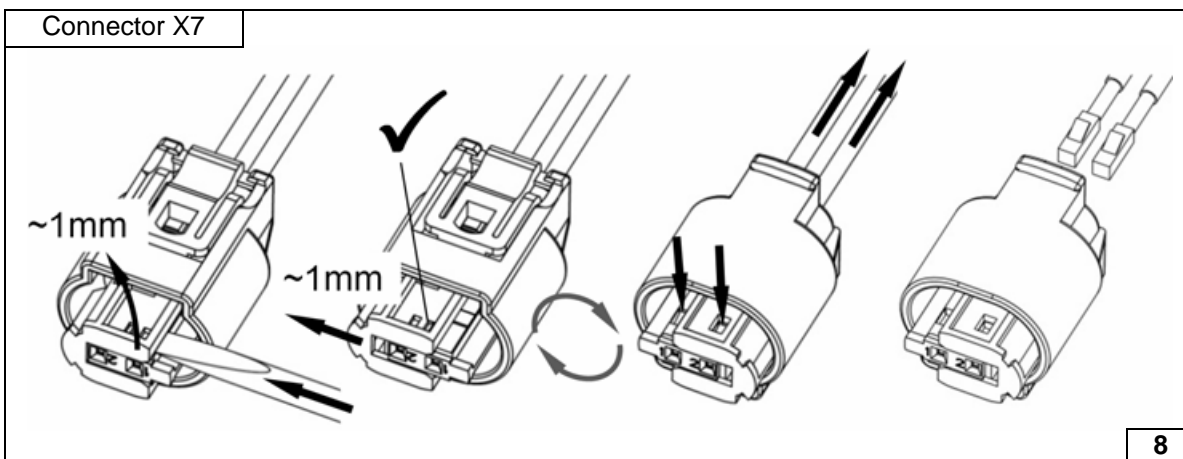

Dismantling metering pump connector



Electrical System

Positive wire

- 1 Positive wire on positive battery terminal

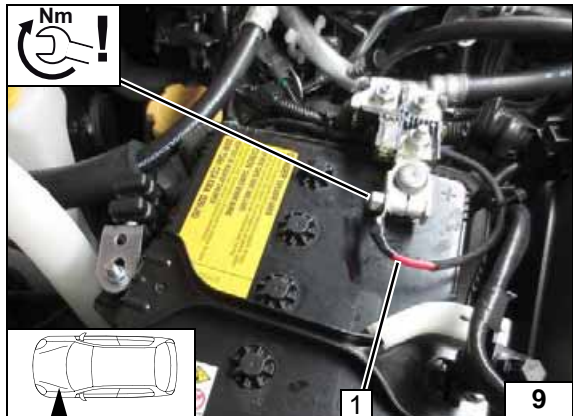

Wiring harness pass through

- 1 Punch 5mm dia. hole into rubber plug at position 1.
- 2 Wiring harnesses of heater, heater control

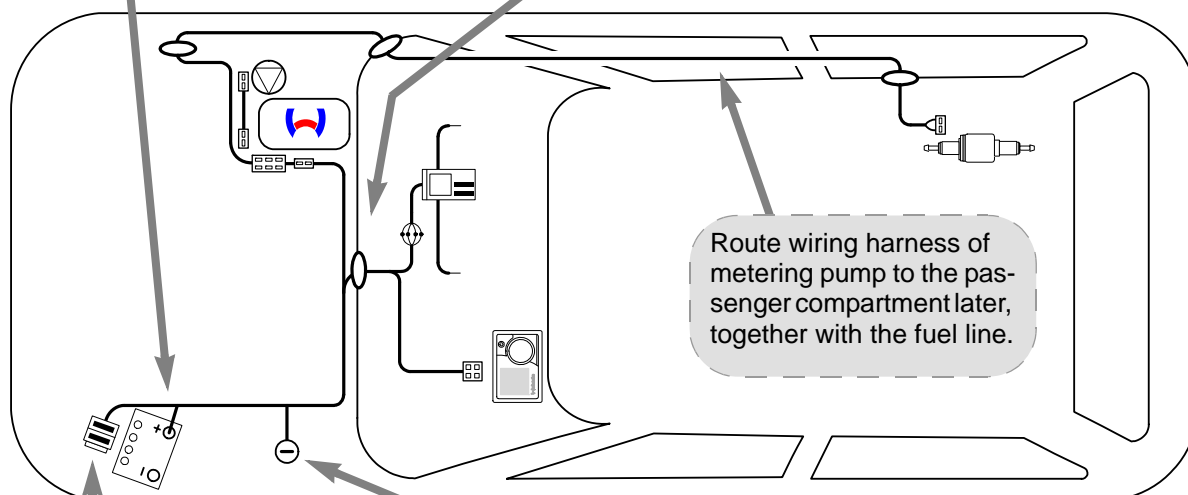
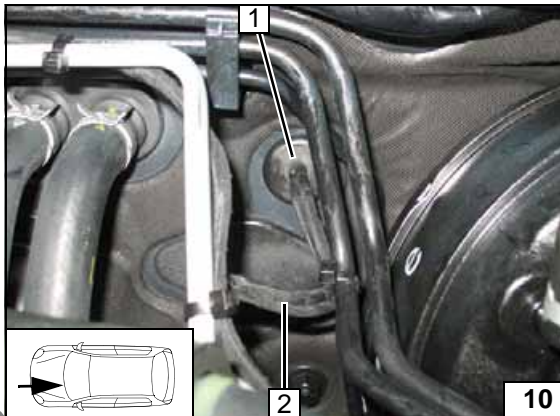

Wiring harness routing diagram

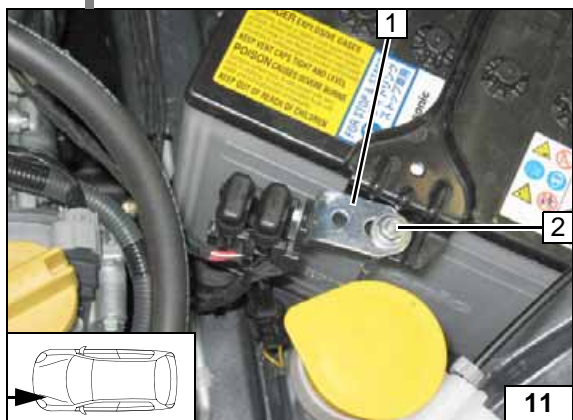

Engine compartment fuse holder

- 1 Angle bracket
- 2 Fastening bolts of battery, M6 flanged nut

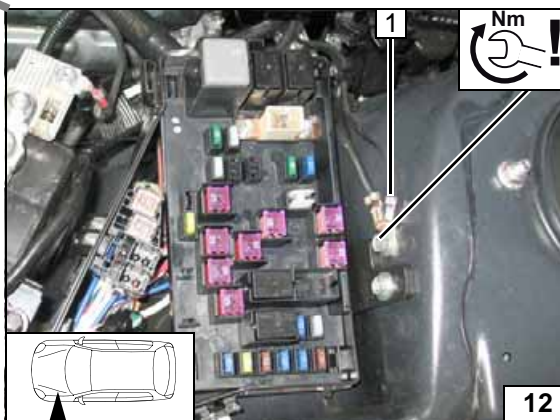

Earth wire

- 1 Earth wire on original vehicle earth support point





Fan Controller



System wiring diagram

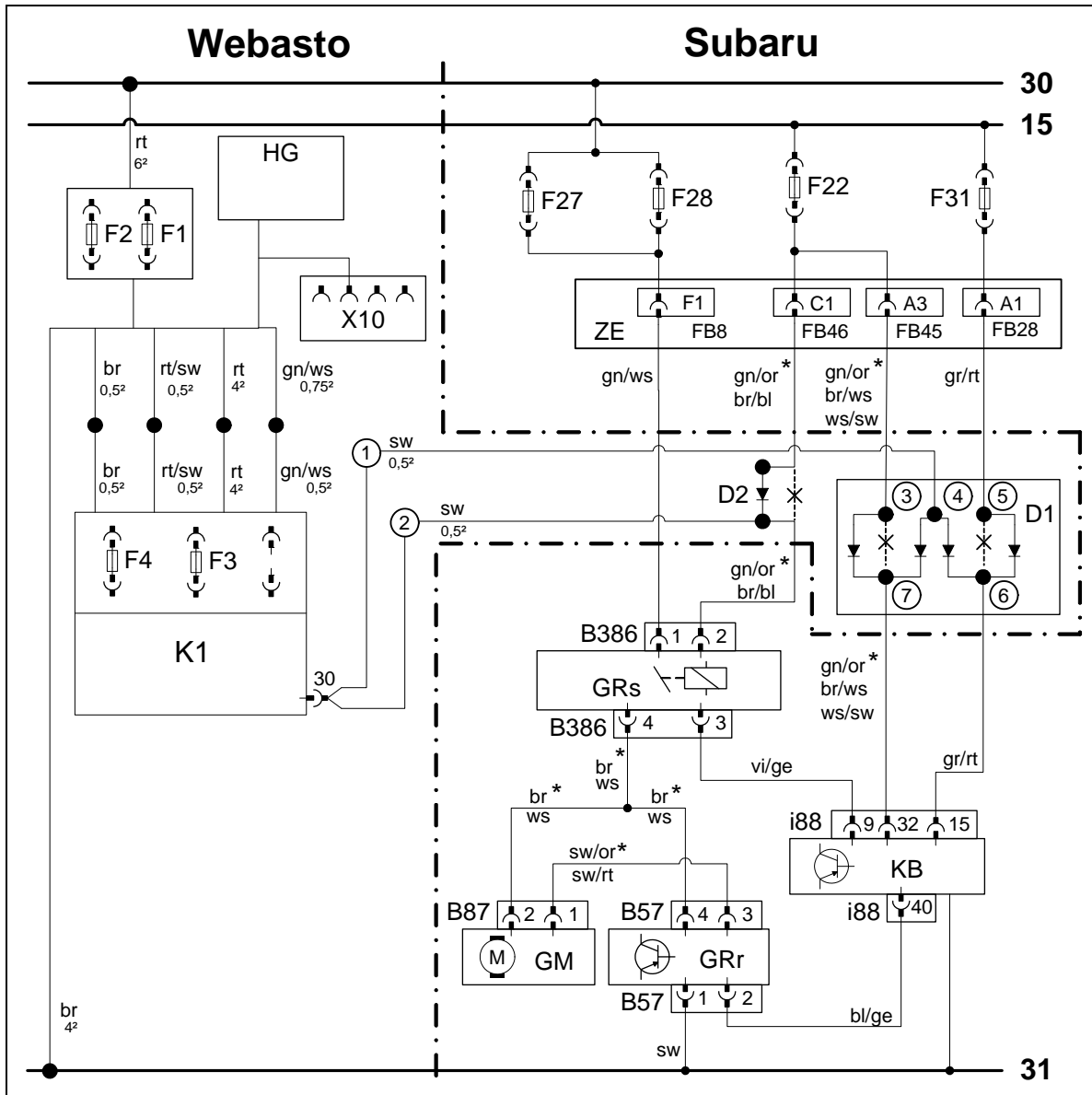

Webasto components		Vehicle components		Colours and symbols	
HG	TT-Evo heater	F22	10A / 15A fuse	rt	red
X10	4-pin connector of heater control	F27	15A fuse	ws	white
K1	Fan relay	F28	15A fuse	sw	black
F1	20A fuse	F31	7.5A fuse	br	brown
F2	30A fuse	ZE	Central electrical box	gn	green
F3	1A fuse	C1	24-pin connector C B52 of central electrical box, pin 1	bl	blue
F4	15A fuse	A3	20-pin connector A (i5) of central electrical box, pin 3	ge	yellow
D1	Diode group (4x3A)	A1	20-pin connector A (i5) of central electrical box, pin 1	or	orange
D2	3A diode			vi	violet
		GRs	Fan relay		
		B386	5-pin connector of GRs		
		KB	A/C control panel	*	Wiring colours, depending on equipment
		i88	40-pin connector of KB		
		GM	Fan motor	X	Cutting point
		GRr	Fan controller		Wiring colours may vary.

Legend

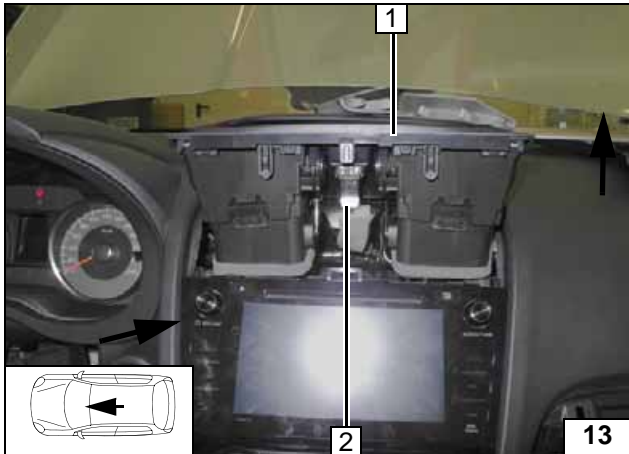

A/C Control Panel Installation Aid

Pull air outlet **1** from the clips in the opposite direction of travel and detach connector **2**.



**Dismantling
air outlet**

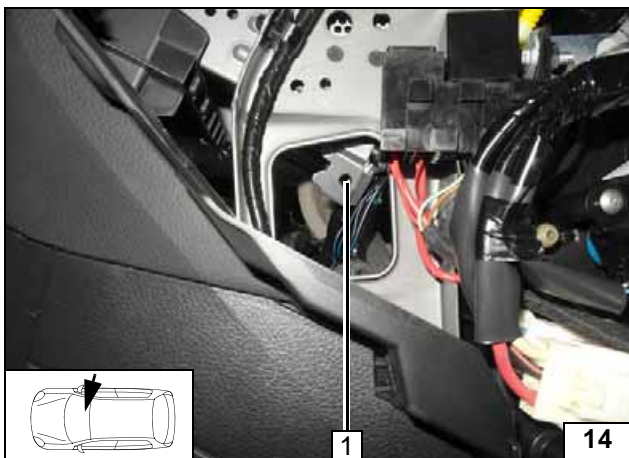

Remove original vehicle A/C control panel bolt Klimabedienteil at position **1**.



**Removing
bolt**

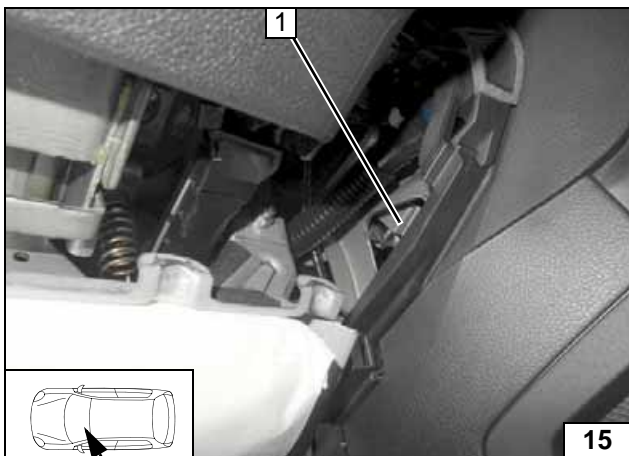

Remove original vehicle A/C control panel bolt at position **1** (covered).



**Removing
bolt**

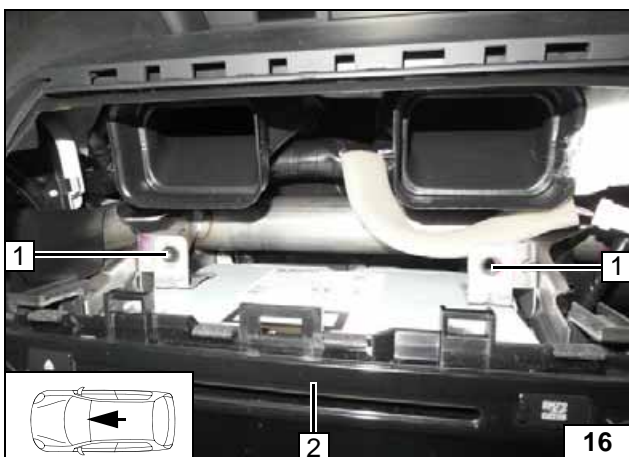

Remove original vehicle bolts of A/C control panel [2x] at position **1**.



2 A/C control panel

**Removing
A/C control
panel**

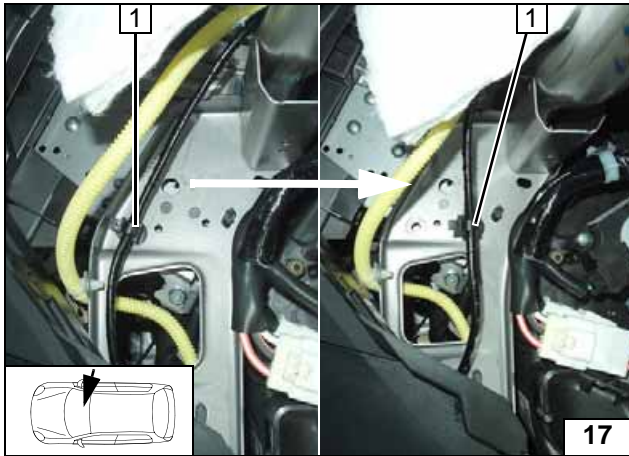
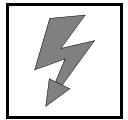

Fan controller

Move original vehicle wiring harness (if present) with clip 1 as shown.

Moving wiring harness

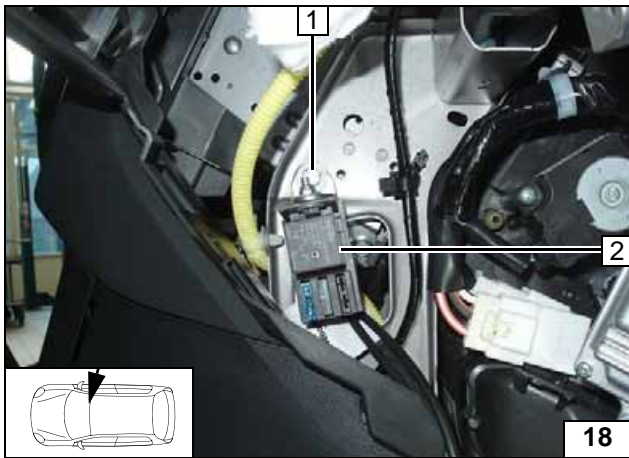

- 1 M6x25 bolt premounted, existing hole, flanged nut
- 2 Passenger compartment relay and fuse holder

Installing passenger compartment relay and fuse holder

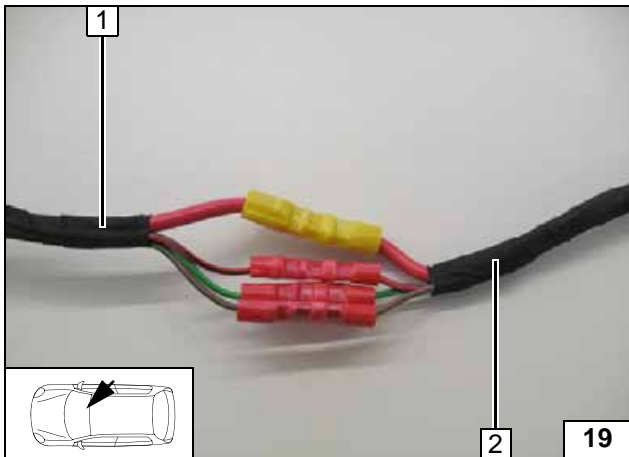

- 1 Passenger compartment relay and fuse holder wiring harness
- 2 Wiring harness of heater

Connecting same colour wires of wiring harnesses

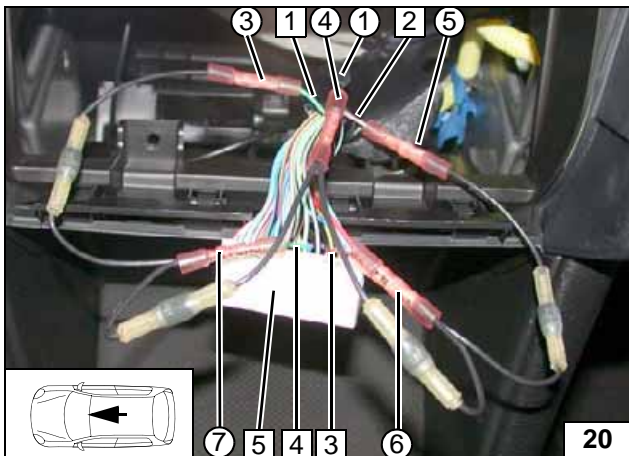

Connection to 40-pin connector i88 (see next figure) 5, pin 15 and 32 of A/C control panel.

- 1 Green/orange (gn/or) or green/yellow (gn/ge) wire of terminal 15
- 2 Grey/red (gr/rt) wire of terminal 15
- 3 Grey/red (gr/rt) wire of connector i88, pin 15
- 4 Green/orange (gn/or) or green/yellow (gn/ge) wire of connector i88, pin 32
- ① Black (sw) wire of K1/30
- ③ Black (sw) wire of D1
- ④ Black (sw) wire of D1
- ⑤ Black (sw) wire of D1
- ⑥ Black (sw) wire of D1
- ⑦ Black (sw) wire of D1



Connecting A/C control panel

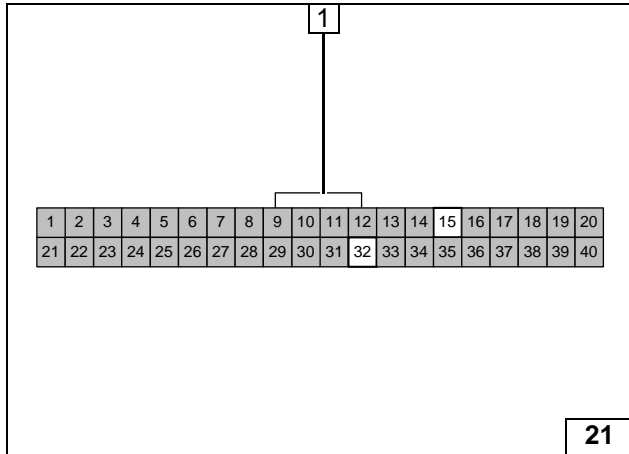

1 40-pin connector i88, on contact side

Connector i88 of A/C control panel

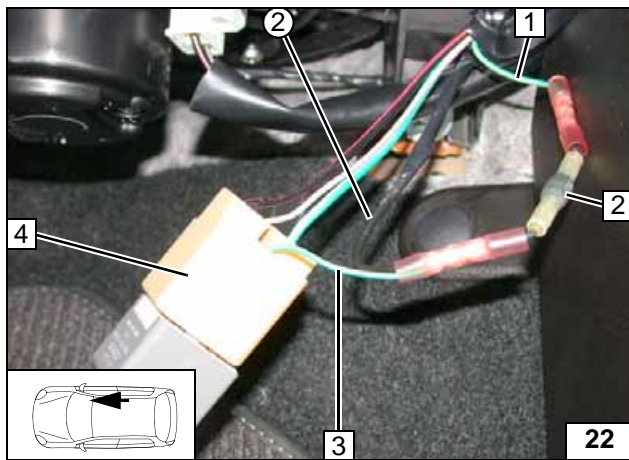

Watch direction of flow of diode D2 2.

- 1 Green/orange (gn/or) or brown/blue (br/bl) wire of connector C, pin 1 (FB46) ZE
- 3 Green/orange (gn/or) or brown/blue (br/bl) wire of connector B386 from fan relay, pin 2
- 4 5-pin connector B386 / PIN 2 of fan relay
- ② Black (sw) wire of K1/30



Connecting fan relay

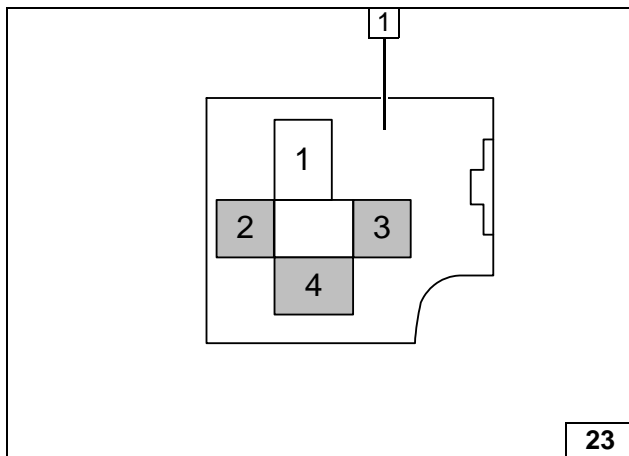

1 5-pin connector B386, on contact side

Connector B386 of fan relay

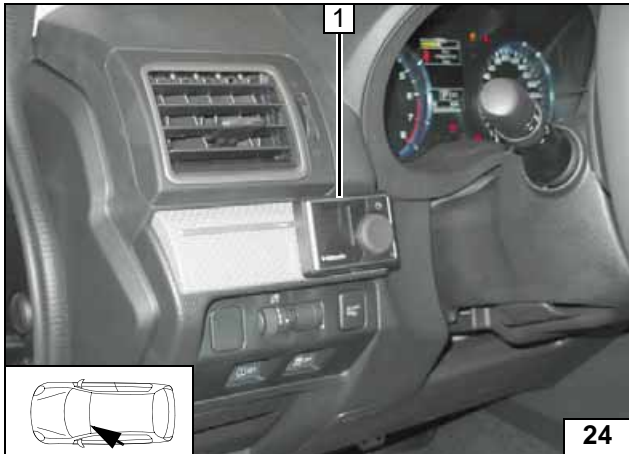

MultiControl CAR Option

- 1 Installation frame



Installing
MultiControl
CAR

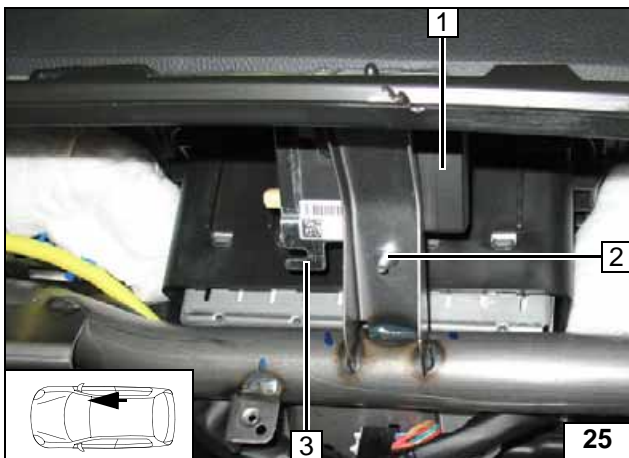

Remote Option (Telestart)

- 1 Receiver
- 2 M5x16 bolt, flanged nut, existing hole
- 3 Bracket



Installing
receiver

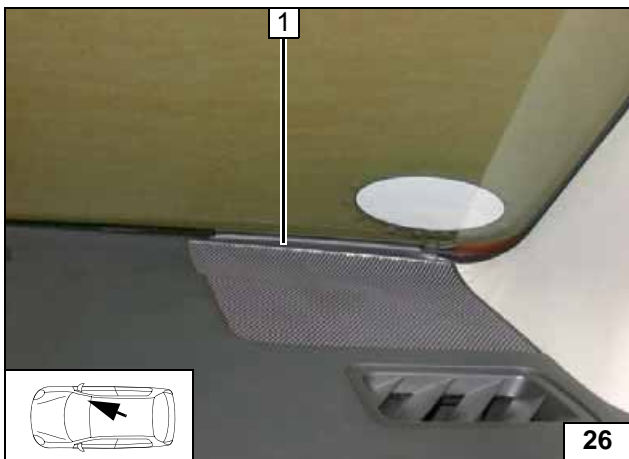

- 1 Aerial

Installing
aerial

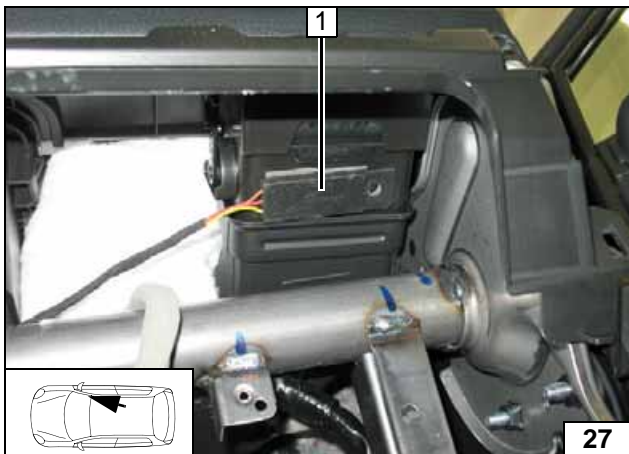

Temperature sensor T100 HTM

Fasten temperature sensor 1 with double-sided adhesive tape.



Installing
tempera-
ture sensor

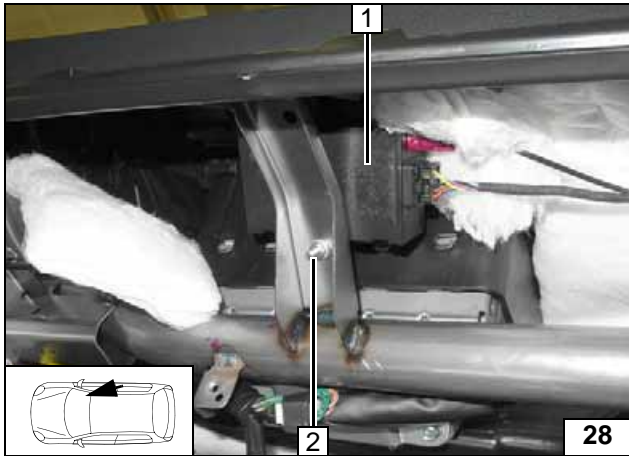
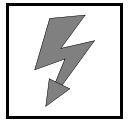

ThermoCall Option

- 1 Receiver
- 2 M5x16 bolt, flanged nut, existing hole

Installing receiver

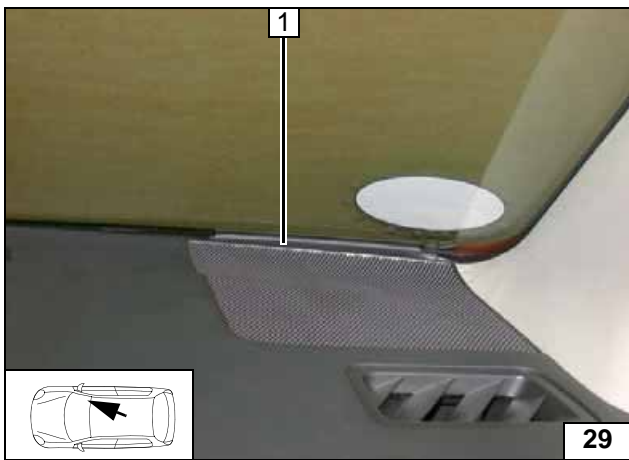

- 1 Aerial (optional)

Installing aerial

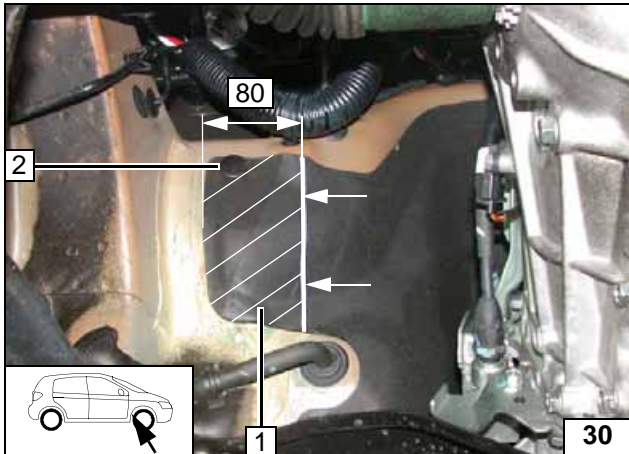

Preparing Installation Location



Shown on vehicle without exhaust gas recirculation.

Remove retaining clip 2, cut out insulation mat 1 and discard.

Cutting out insulation mat

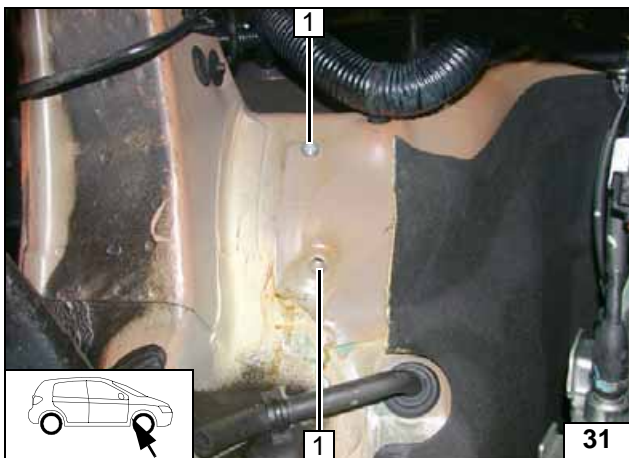

1 Drill out hole to 9.1 mm dia., rivet nut [2x each]

Installing rivet nut

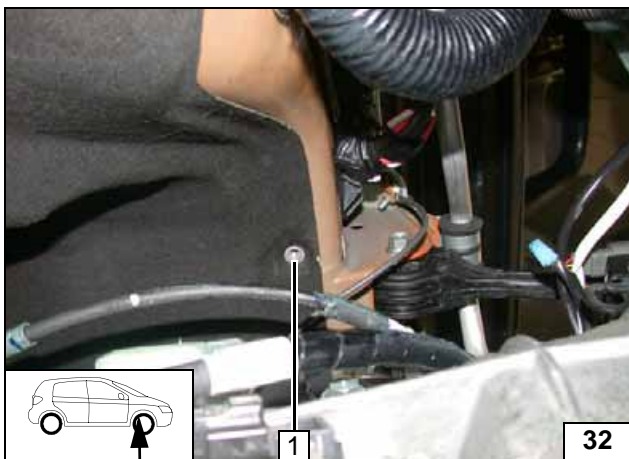

Remove retaining clip, drill out existing hole to 9.1mm dia., insert rivet nut.



Installing rivet nut

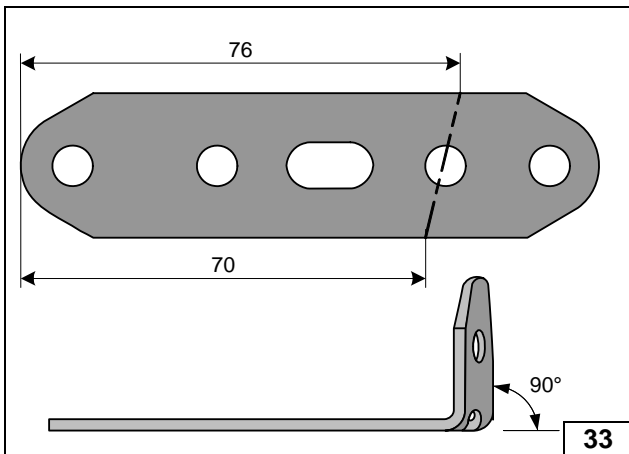

Angling down perforated bracket

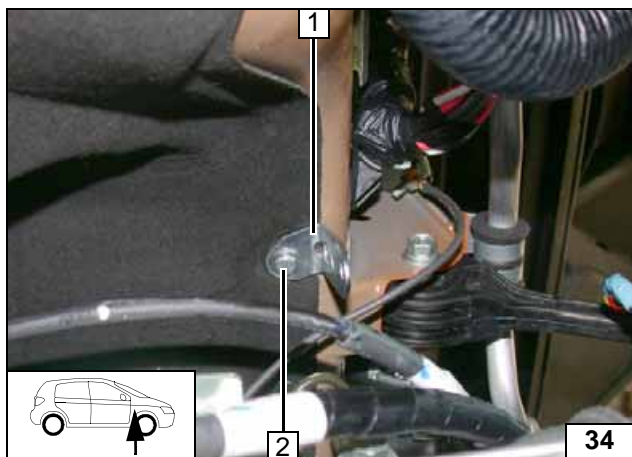

Insert 5mm shim between perforated bracket 1 and rivet nut.

- 2 M6x20 bolt, spring lockwasher, 5 mm shim



Installing perforated bracket

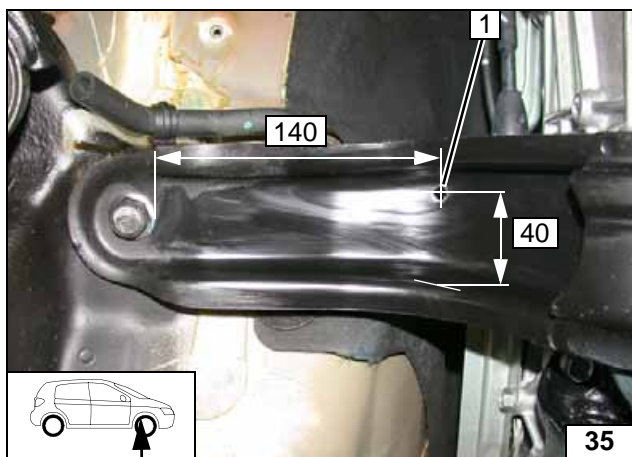

Vehicle with Euro 5 emission standard

- 1 7 mm dia. hole

Hole in cross member

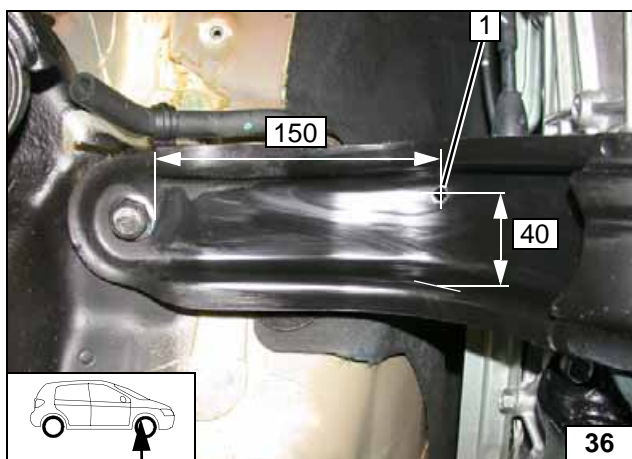

Vehicle with Euro 6 emission standard

- 1 7 mm dia. hole

Hole in cross member

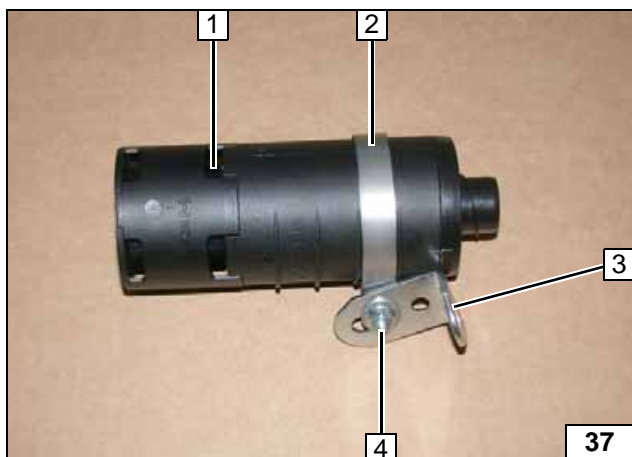

All vehicles

- 1 Loosely mount combustion air silencer
- 2 51 mm dia. clamp
- 3 Angle bracket
- 4 M5x16 bolt, flanged nut

Loosely pre-mounting combustion air silencer

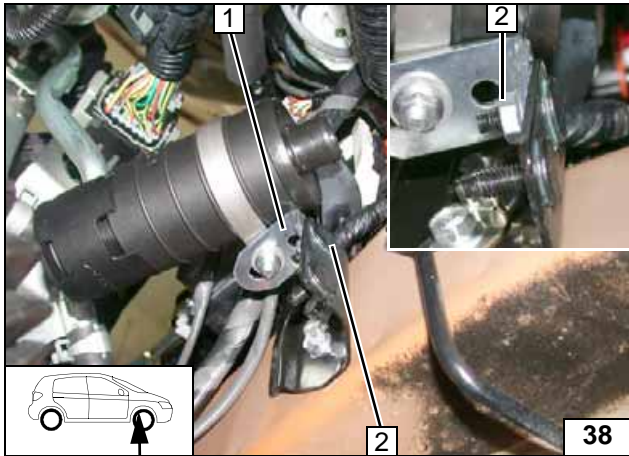

- 1 Angle bracket
- 2 Original vehicle stud bolt (upper), M6 flanged nut



Installing combustion air silencer

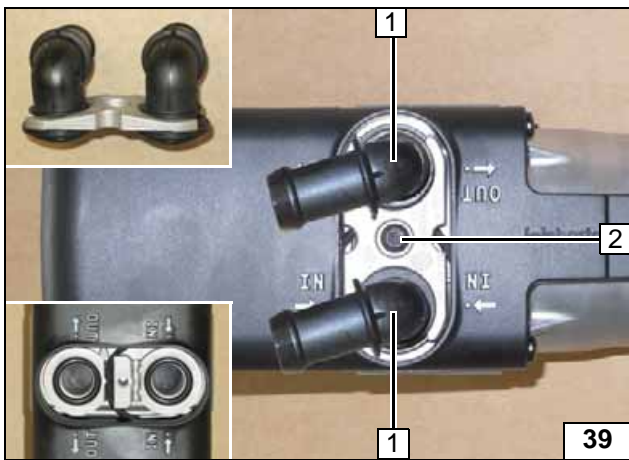

Preparing Heater

- 1 Water connection piece, sealing ring [2x each]
- 2 5x15 self-tapping bolt, retaining plate of water connection piece



Installing water connection piece

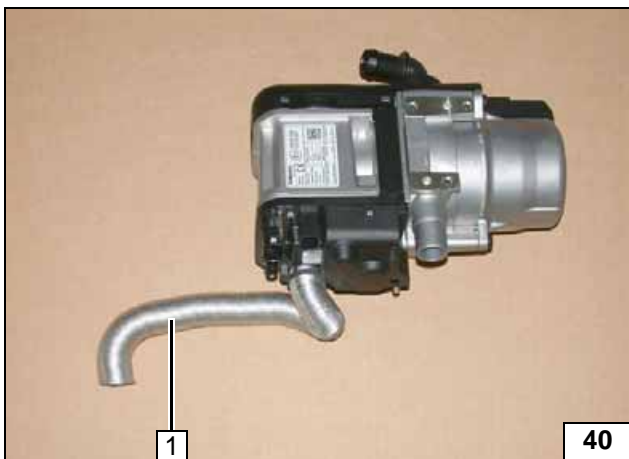

Vehicle with Euro 5 emission standard

- 1 Combustion air pipe



Premounting combustion air pipe

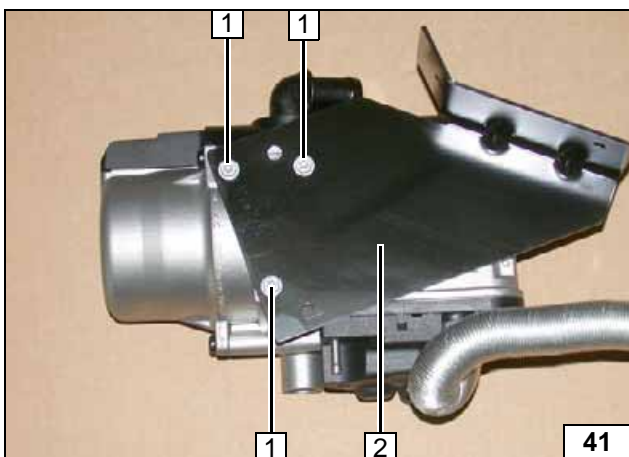

- 1 5x13 self-tapping bolt [3x]
- 2 Bracket

Installing bracket

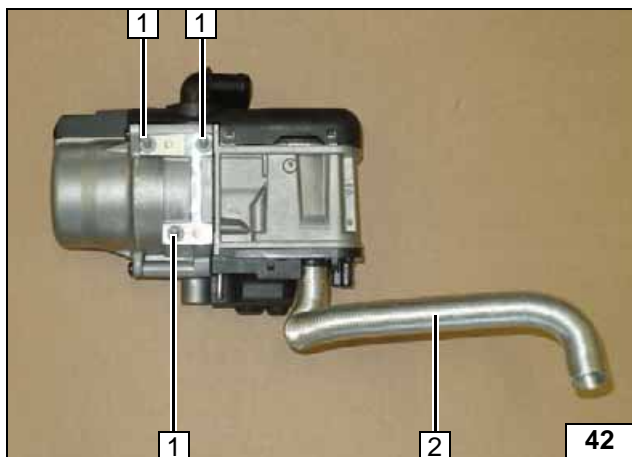

Vehicle with Euro 6 emission standard

- 1 M6/M5x25 self-tapping stud bolt [3x]
- 2 Combustion air pipe



Premounting heater

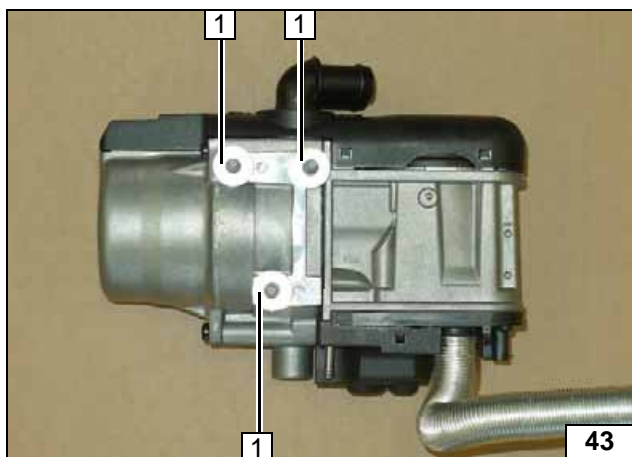

- 1 10mm shim [3x]

Fitting shims

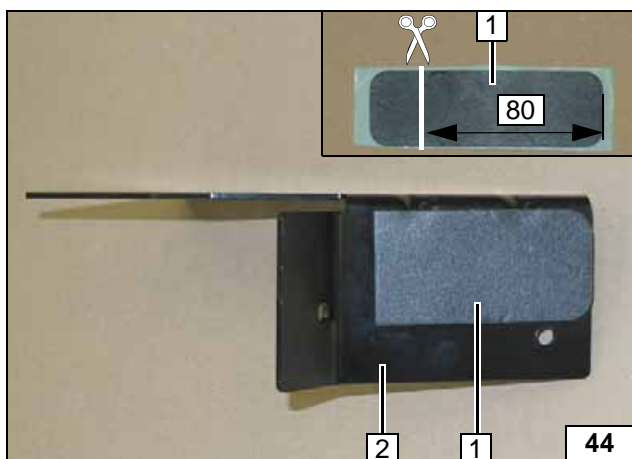

Cut self-adhesive foam 1 to length, stick on as shown.

- 2 Bracket



Preparing bracket

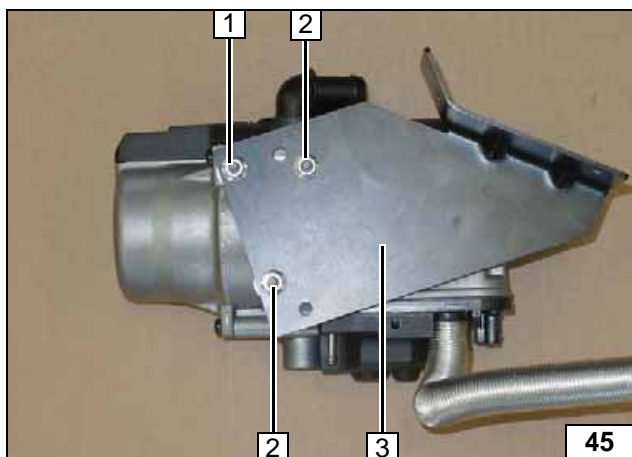

Drill out hole in bracket 3 at position 2 [2x] to 7mm.

- 1 M6 flanged nut
- 2 M6 flanged nut [2x]



Installing bracket

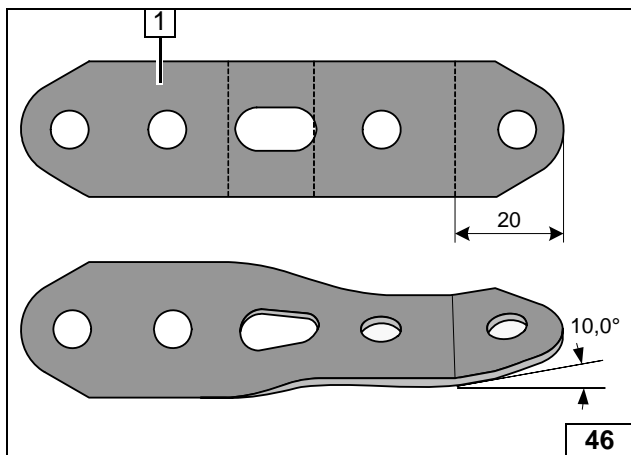

All vehicles

- 1 Twist perforated bracket by 45° in longitudinal direction and angle down by 10°

Preparing perforated bracket

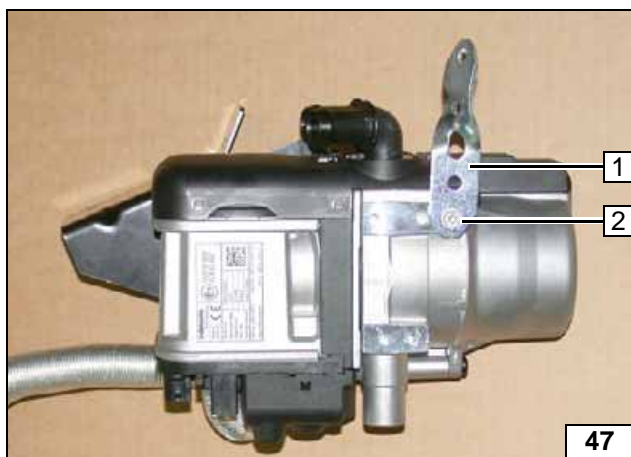

- 1 Loosely install perforated bracket
- 2 5x13 self-tapping bolt

Loosely installing perforated bracket

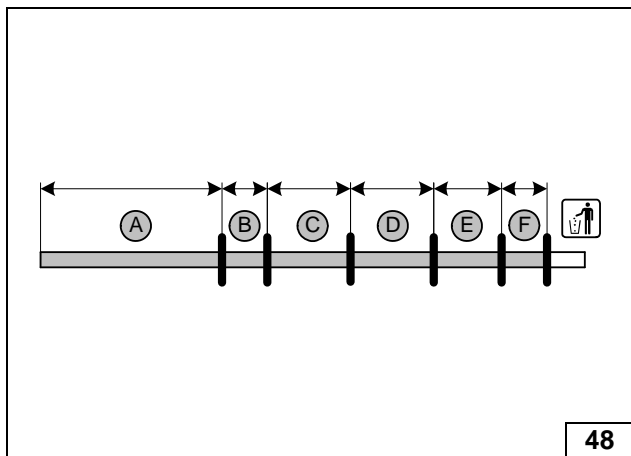

- A = 470
- B = 90
- C = 330
- D = 310
- E = 260
- F = 60

Cutting hoses to length

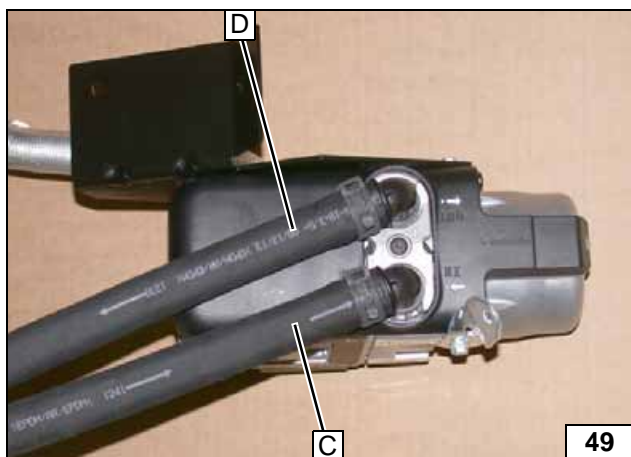

All spring clips 25 mm dia.



Premounting hoses

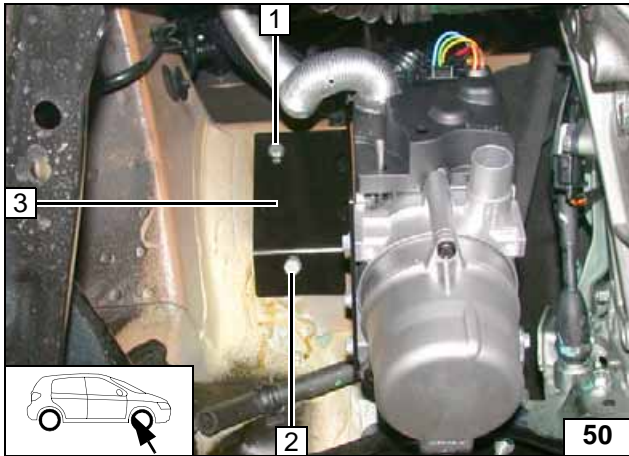

Installing Heater

Shown on a vehicle with Euro 5 emission standard!

Insert 5mm shim between bracket 3 and rivet nut at position 2.

- 1 M6x20 bolt, spring lockwasher
- 2 M6x25 bolt, spring lockwasher, 5 mm shim



Installing heater

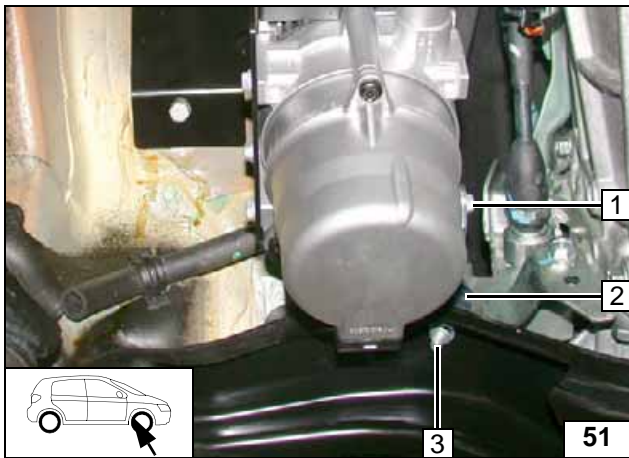

Tighten 5x13 self-tapping bolt 1.

- 2 Perforated bracket
- 3 M6x20 bolt, flanged nut



Installing heater



- 1 Heater wiring harness connector [2x]

Installing wiring harness

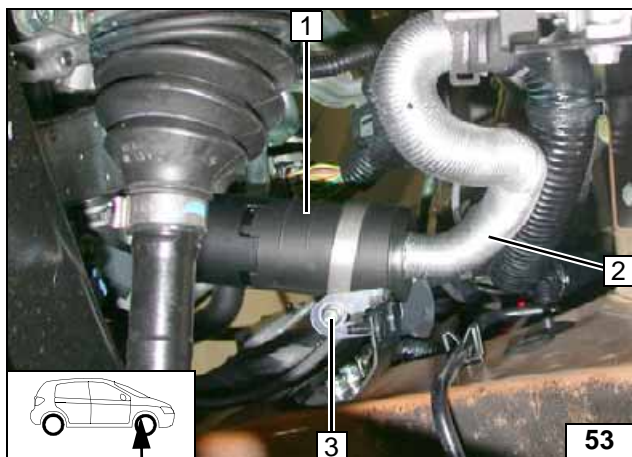
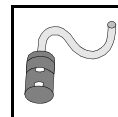

Combustion Air

Twist silencer 1 onto combustion air pipe 2.
Tighten M5x16 bolt 3.

**Installing
silencer**



Fuel

CAUTION!

Open the vehicle's fuel tank cap, ventilate the tank and then re-close the tank lock.

Catch any fuel running off in an appropriate container.

Route fuel line and metering pump wiring harness so that they are protected against stone impact. Unless specified otherwise, always fasten using cable ties.

Provide rub protection for fuel line and wiring harness in areas where there are sharp edges.

WARNING!

The fuel line and wiring harness are routed to the metering pump as shown in the wiring harness routing diagram.

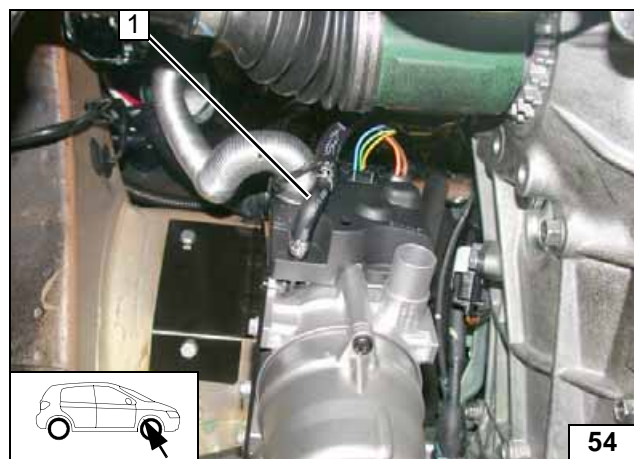

1 Fuel line, 90° moulded hose, 10 mm dia. clamp [2x]

**Connect-
ing heater**

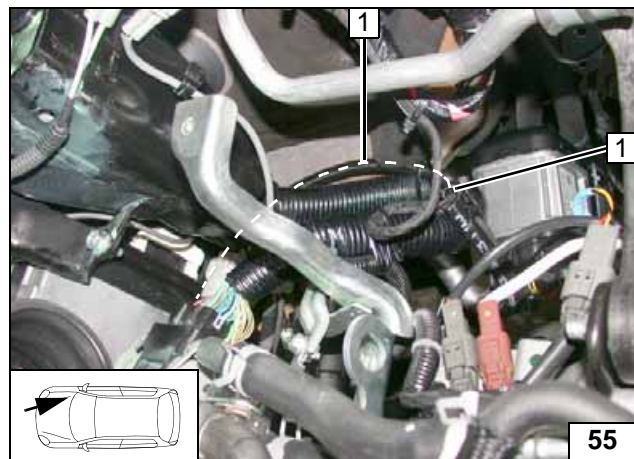

Route fuel line and wiring harness of metering pump in 10mm dia., 1130mm long corrugated tube 1 to the top along the firewall.



**Routing
lines**

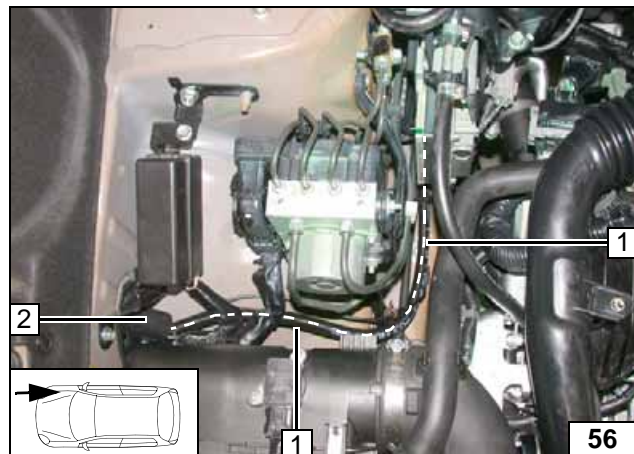

Route fuel line and wiring harness of metering pump in 10mm dia. corrugated tube 1 to the right wheel well through original vehicle pass through 2.



**Routing
lines**

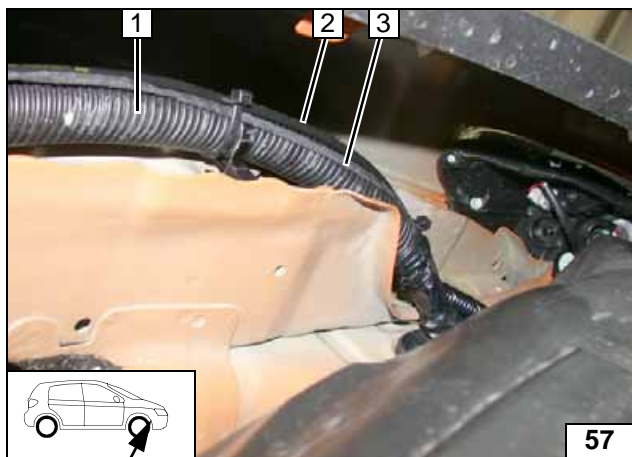

Route fuel line 2 and metering pump wiring harness 3 to the rear of the wheel well along original vehicle wiring harness 1.



Routing lines

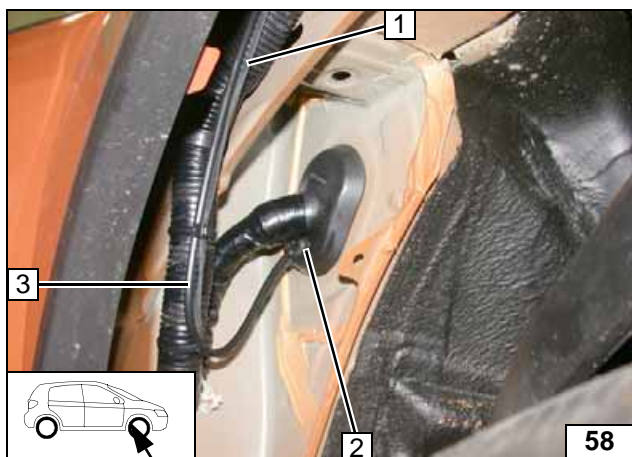

Route fuel line 3 and metering pump wiring harness 1 through original vehicle pass through 2 into passenger compartment.



Routing lines

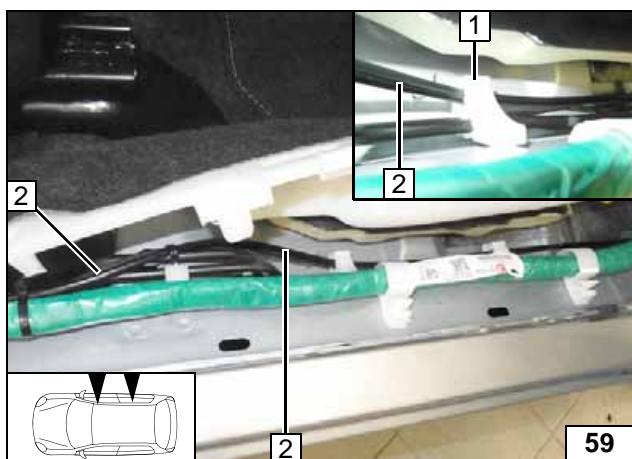

Route fuel line and wiring harness of metering pump 2 in the passenger compartment (front and rear) to the rear within cable duct along original vehicle fuel lines.



Routing lines

- 1 Mounting/bracket of fuel lines

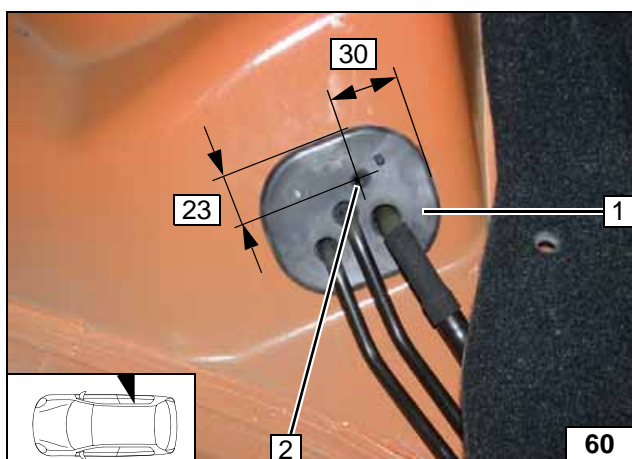

- 1 Protective rubber plug
- 2 7 mm dia. hole

Hole in protective rubber plug

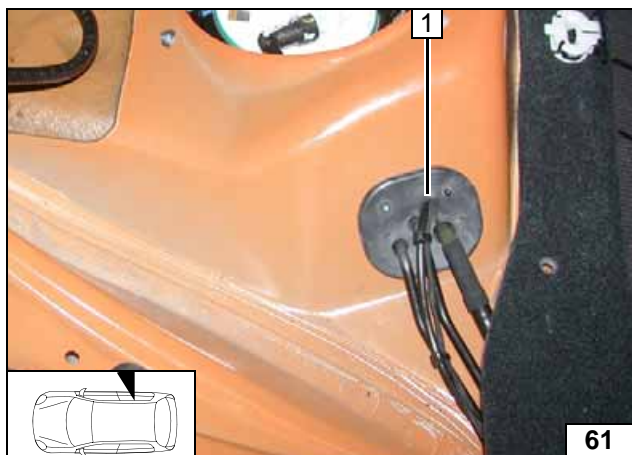

Route fuel line and metering pump wiring harness to the underbody through hole in protective rubber plug 1.



Routing lines

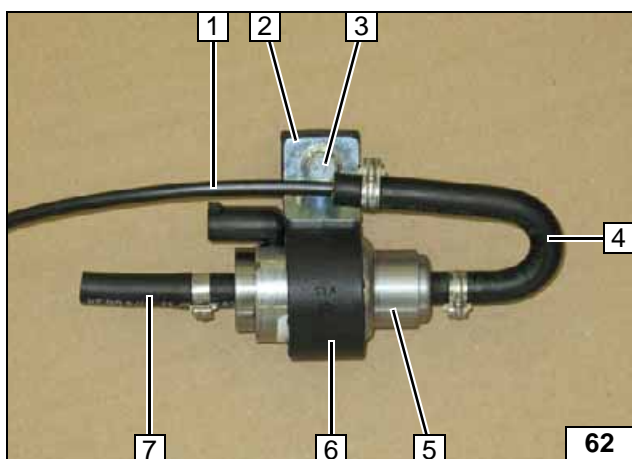

Cut off 1000mm from fuel line.

- 1 1000 mm long fuel line
- 2 Support angle bracket
- 3 Insert M6x25 bolt
- 4 180° moulded hose, 10 mm dia. clamp [2x]
- 5 Metering pump
- 6 Metering pump mount
- 7 Hose section, 10 mm dia. clamp



Premounting metering pump

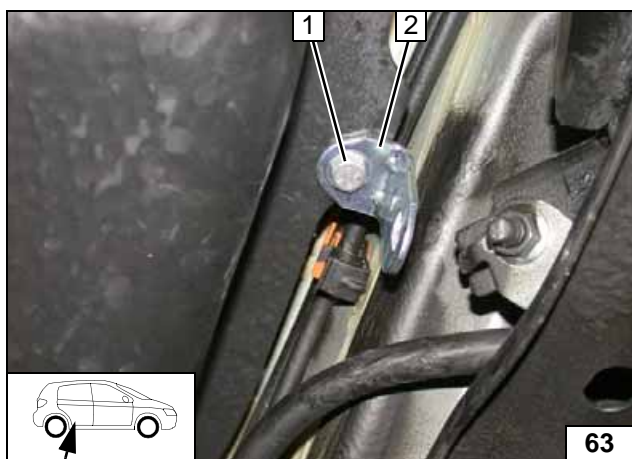

- 1 M6x20 bolt, flanged nut, existing hole
- 2 Angle bracket

Installing angle bracket

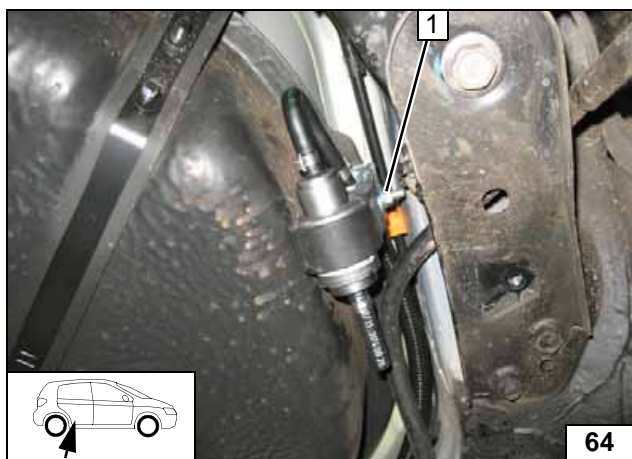

Route fuel line to fuel tank sending unit.

- 1 Flanged nut on M6x25 bolt



Installing metering pump



Fuel tank sending unit depends on vehicle equipment variant.

Version 1

Remove and dismantle fuel tank sending unit on right 1 according to manufacturer's instructions.



Preparing fuel extraction

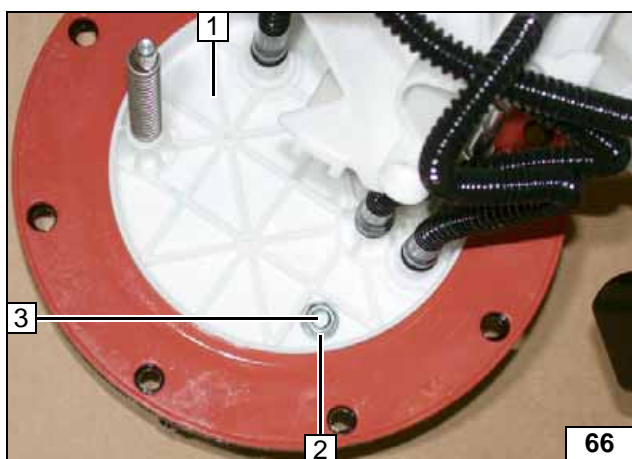

- 1 Fuel tank sending unit
- 2 Flanged nut
- 3 Copy hole pattern, 6 mm dia. hole



Preparing fuel extraction

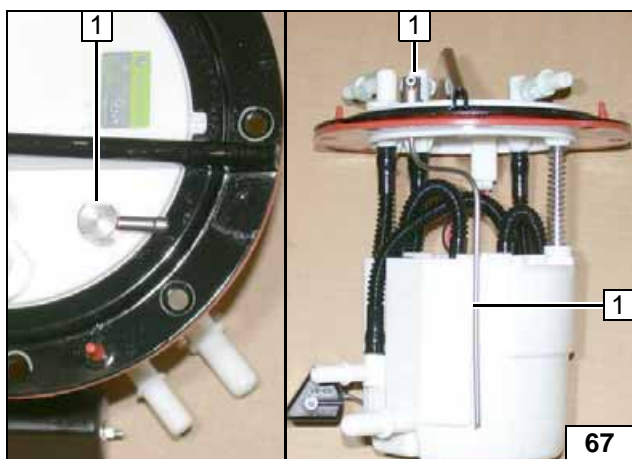

Bend fuel standpipe 1 according to template and cut to length. Complete fuel tank sending unit.



Installing fuel standpipe

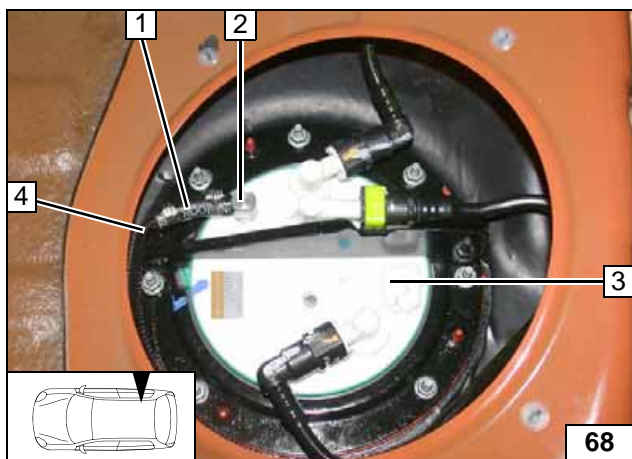

Install fuel tank sending unit 3 according to manufacturer's instructions.

- 1 Hose section, 10 mm dia. clamp [2x]
- 2 Fuel standpipe
- 4 Fuel line of fuel standpipe



Connecting fuel line

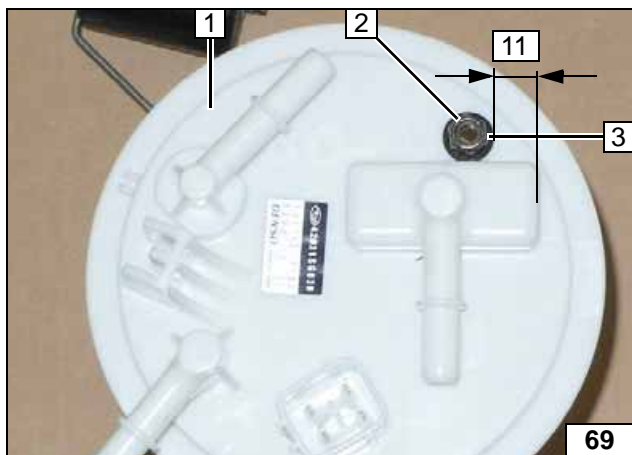

Version 2

Remove fuel tank sending unit on right 1 according to manufacturer's instructions.

- 2 Flanged nut
- 3 Copy hole pattern, 6 mm dia. hole



Preparing fuel extraction



Bend fuel standpipe 1 according to template and cut to length.



Installing fuel standpipe

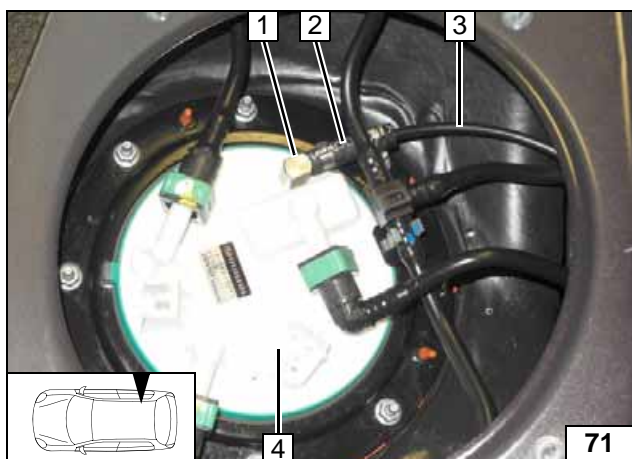

Install fuel tank sending unit 4 according to manufacturer's instructions.

- 1 Fuel standpipe
- 2 Hose section, 10 mm dia. clamp [2x]
- 3 Fuel line of fuel standpipe



Connecting fuel line

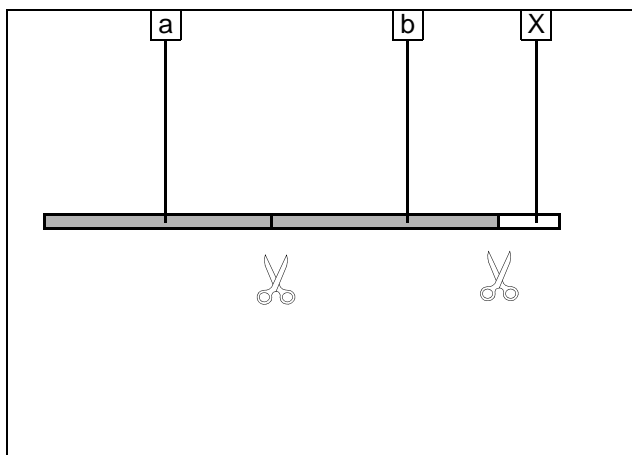

All vehicles

Cut 10mm dia. corrugated tube to length.

a = 750

b = 750

X =



Cutting corrugated tube to length

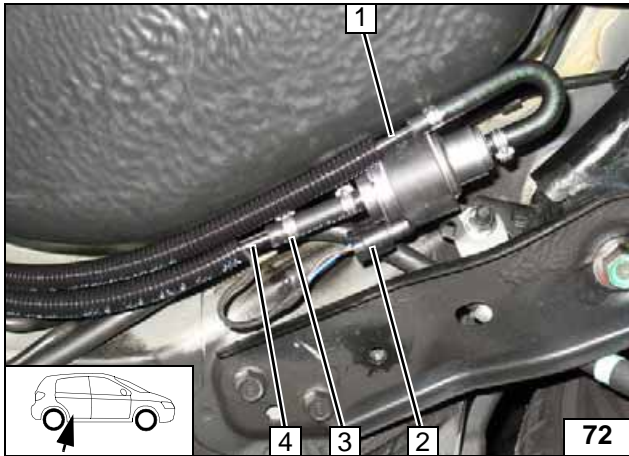
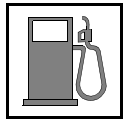

Images show XV.

Push one 750 mm long, 10 mm dia. corrugated tube each onto fuel line of fuel standpipe 1 and fuel line of heater 4.

- 2 Metering pump wiring harness, connector X7 mounted
- 3 10 mm dia. clamp [2x]



**Connect-
ing meter-
ing pump**

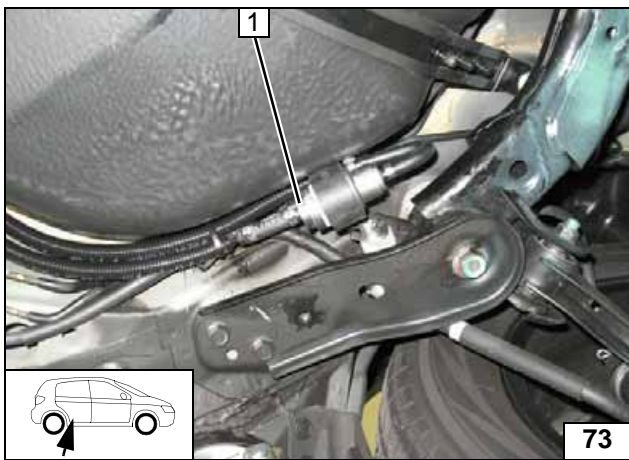

Twist connector of metering pump 1 upwards. Check the position of the components; correct if necessary. Check that they have freedom of movement.



**Aligning
metering
pump**



Coolant Circuit



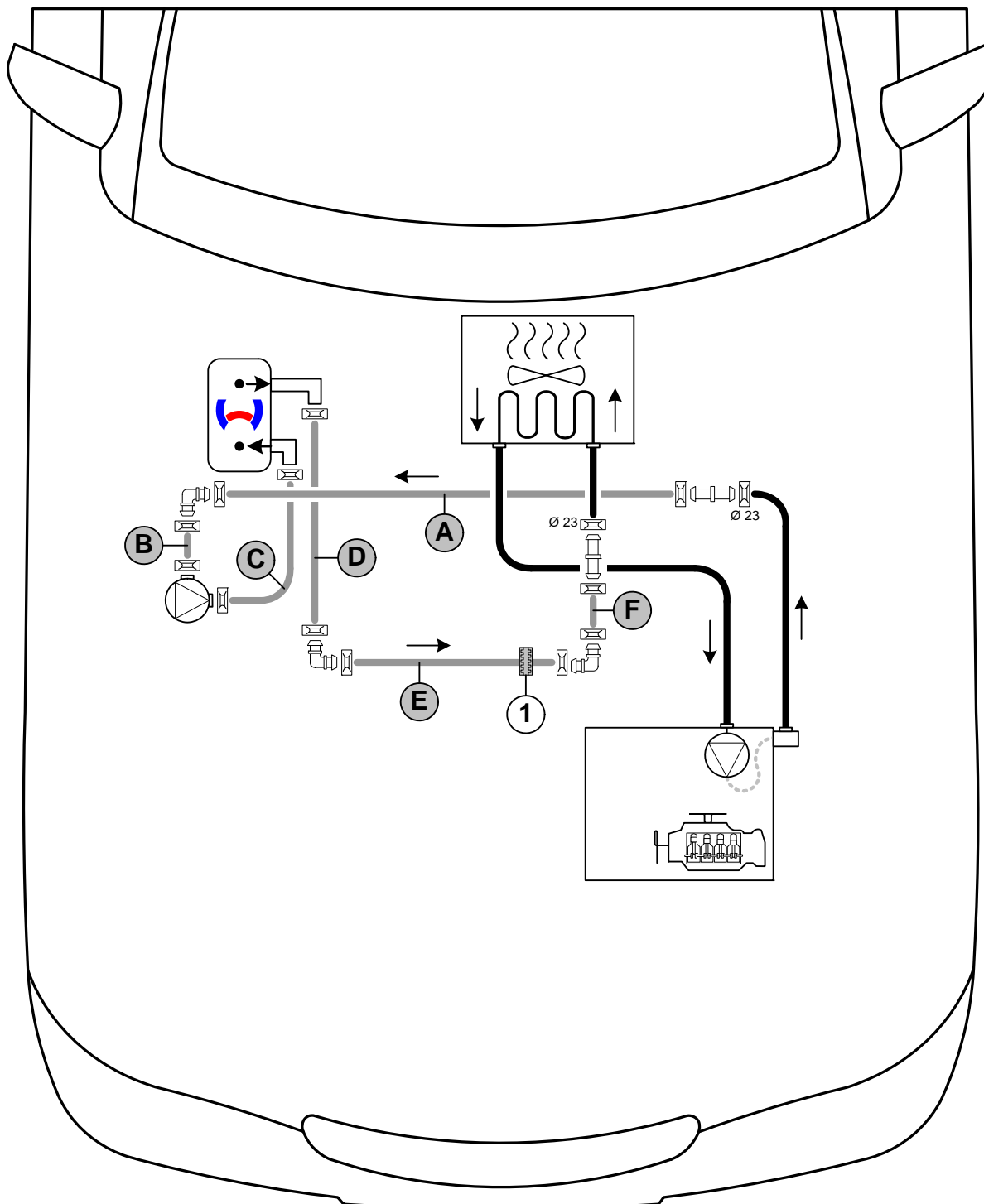

WARNING!

Any coolant running off should be collected in an appropriate container. Route hoses kink-free. Unless specified otherwise, always fasten using cable ties. Position clamps so that other hoses cannot be damaged. The heater must be filled with coolant when installing the hoses.

The connection should be modelled on an 'inline' circuit and based on the following diagram:



Hose routing diagram

All spring clips without a specific designation  = 25 mm dia.
 All connecting pipes  = 16x18 mm dia. All connecting pipes  = 18x18 mm dia.
 1 = Black (sw) rubber isolator 



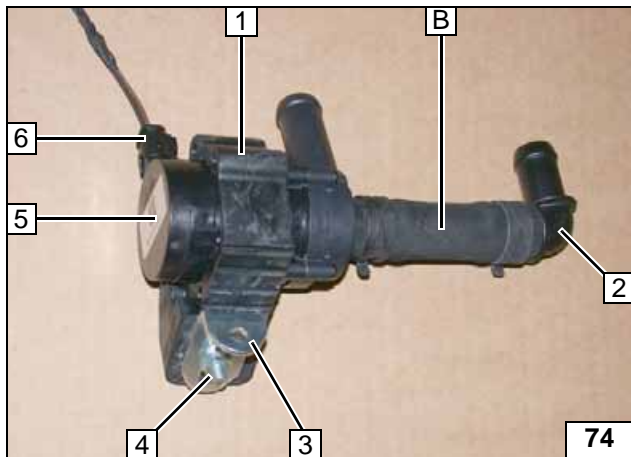

- 1 Circulating pump mount
- 2 Premount 90° connecting pipe
- 3 Angle bracket
- 4 M6x25 bolt, flanged nut
- 5 Circulating pump
- 6 Connector of circulating pump wiring harness

Premounting circulating pump

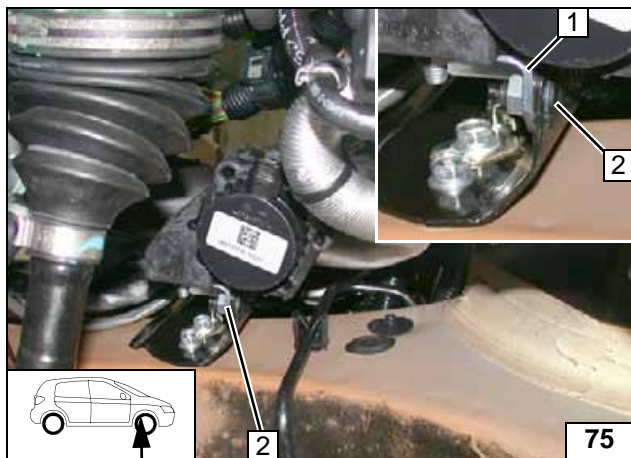

- 1 Angle bracket
- 2 Original vehicle stud bolt (lower), M6 flanged nut

Installing circulating pump

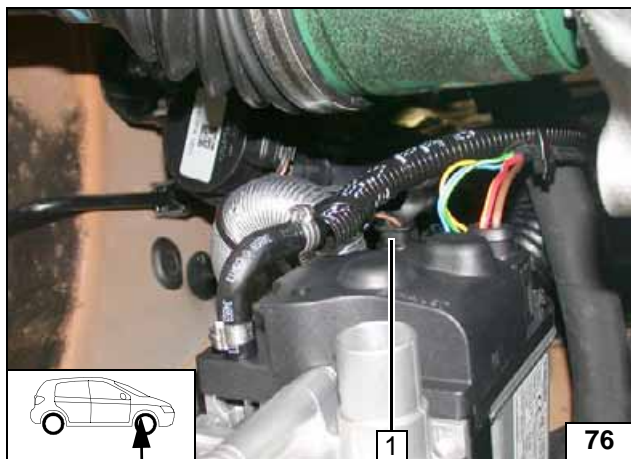

- 1 Circulating pump wiring harness

Mounting wiring harness of circulating pump

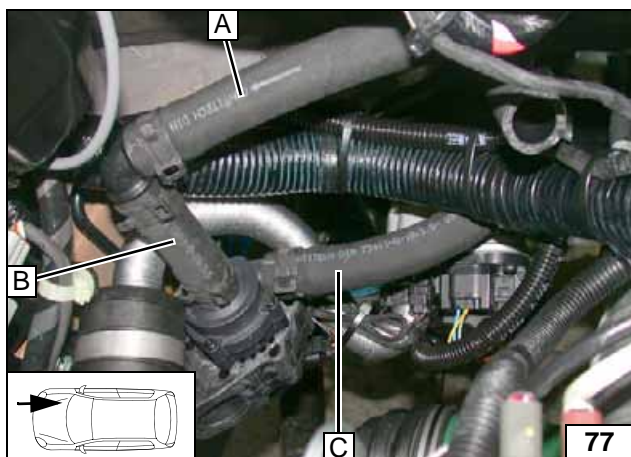

Connecting heater

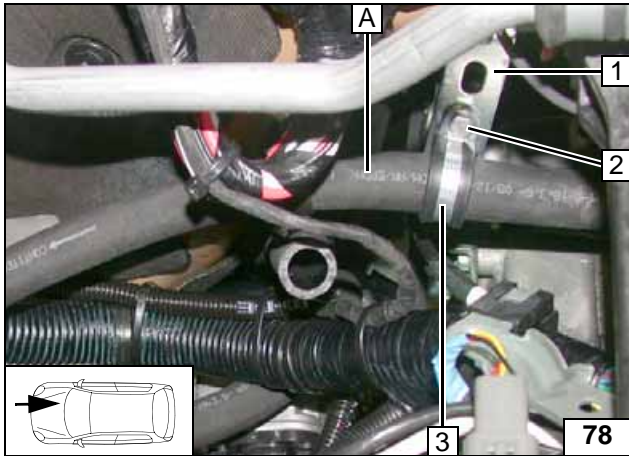

- 1 Perforated bracket
- 2 M6x20 bolt, flanged nut
- 3 25 mm dia. rubber-coated p-clamp

Routing in engine compartment

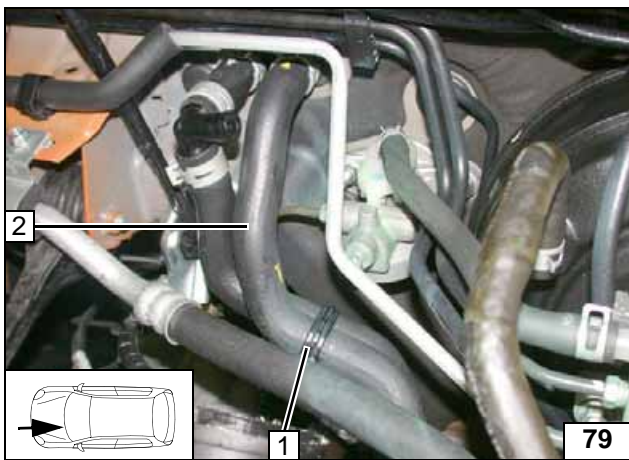

Remove and discard original vehicle spacer bracket 1. Remove hose of engine outlet / heat exchanger inlet 2, spring clips will be re-used.



Cutting point

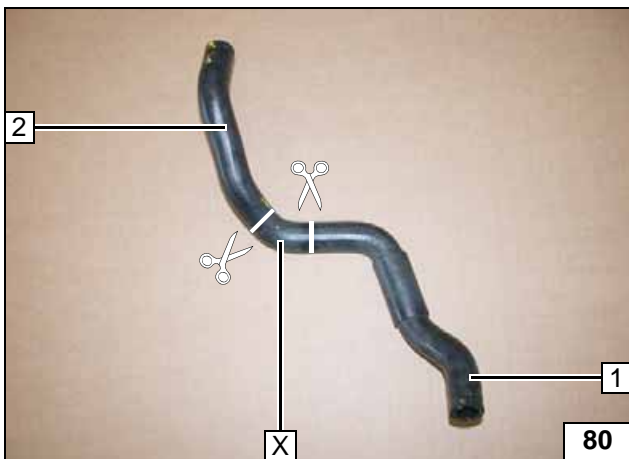

Cut off hose on engine outlet / heat exchanger inlet at markings. Reinstall hose section of engine outlet 1.



- 2 Heat exchanger inlet hose section

X =

Cutting point

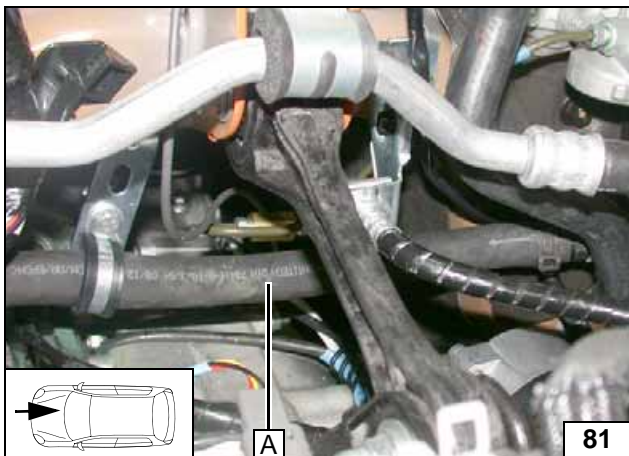

Routing in engine compartment

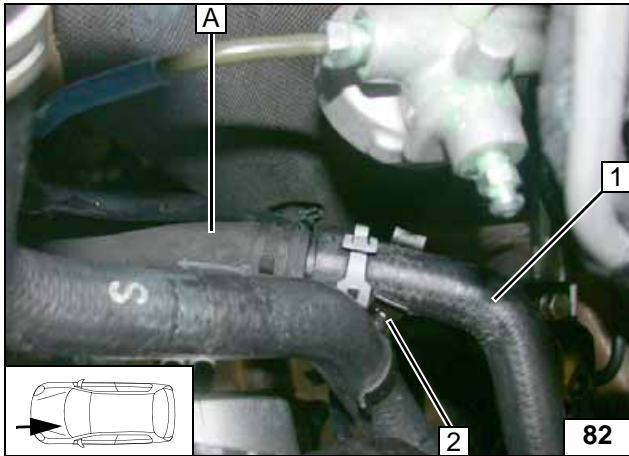

- 1 Engine outlet hose section
- 2 Hose bracket

Connect-
ing engine
outlet

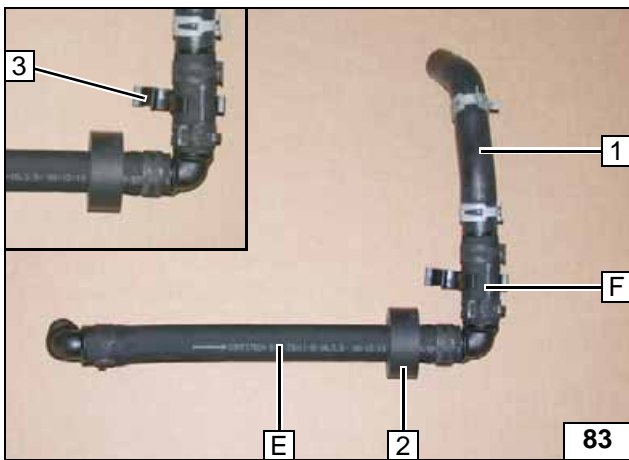

- 1 Heat exchanger inlet hose section
- 2 Push on black (sw) rubber isolator
- 3 Mount hose bracket on hose F

Premount-
ing hoses E
and F

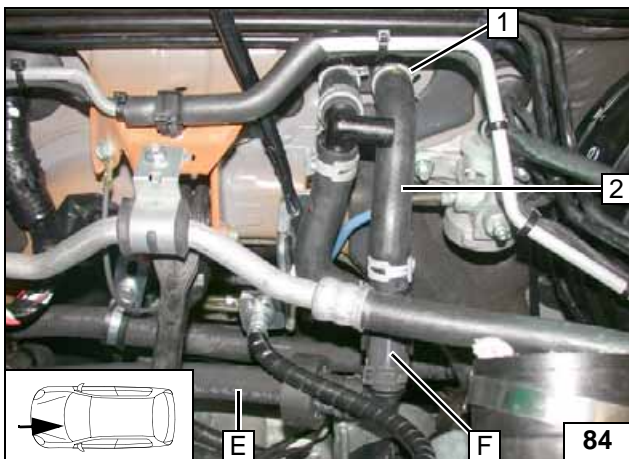

- 1 Original vehicle spring clip
- 2 Hose of heat exchanger inlet

Connect-
ing heat ex-
changer
inlet

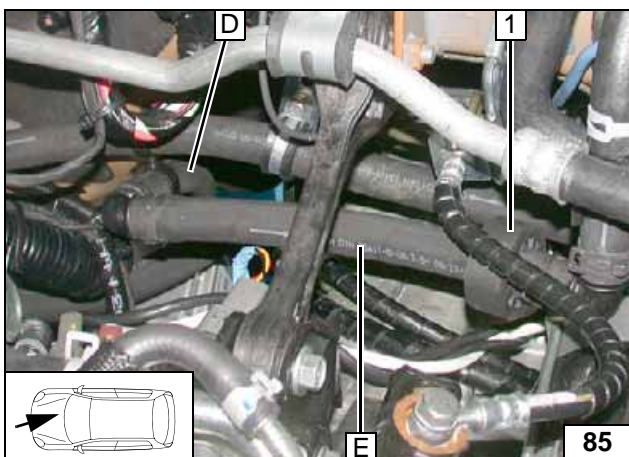

- 1 Align black (sw) rubber isolator

Connect-
ing heater

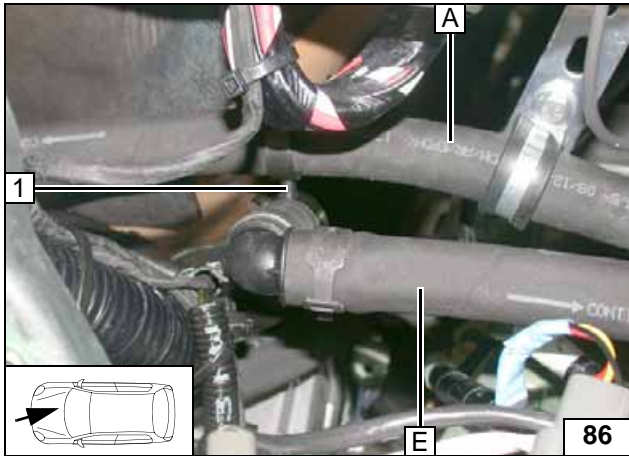

1 Hose bracket

Inserting
hose
bracket

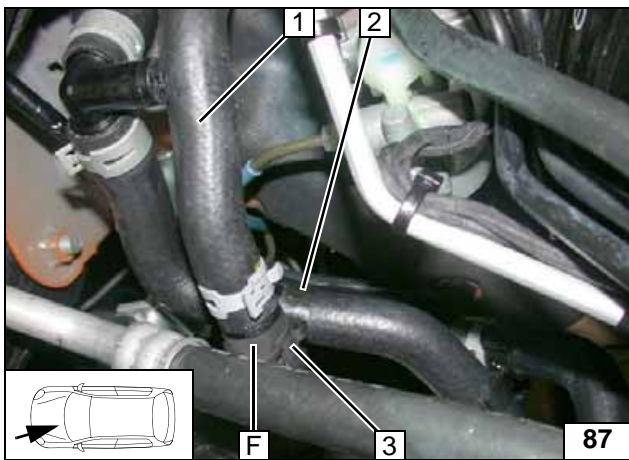

Align hoses. Ensure sufficient distance from adjacent components, correct if necessary.

- 1 Hose of heat exchanger inlet
- 2 Hose bracket on original vehicle hose
- 3 Align spring clip (lock)



Aligning
spring clips



Exhaust for Vehicles with Euro 5 Emission Standard

a1 = 230

a2 = 230

X =

**Preparing ex-
haust pipe**

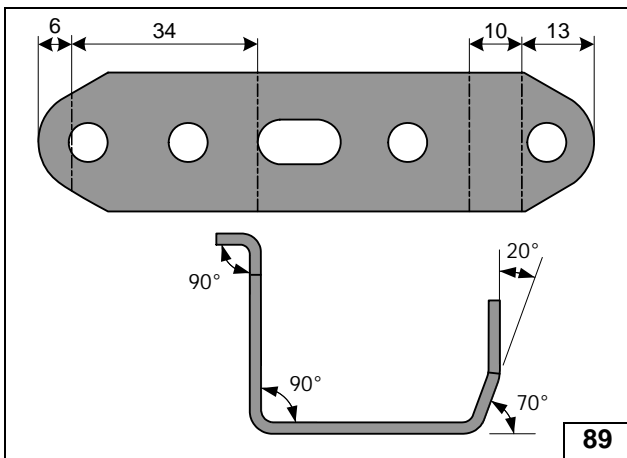
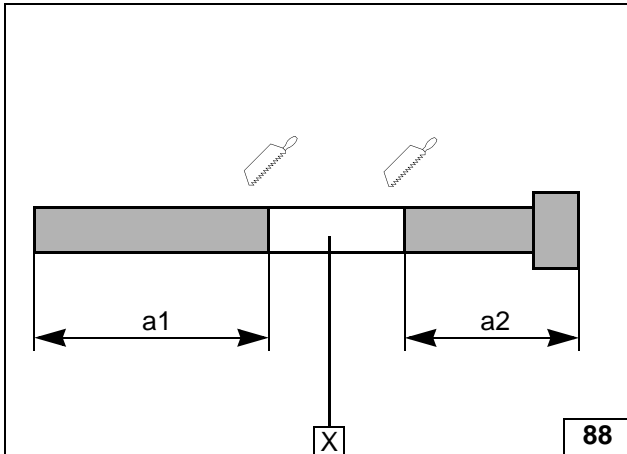

**Angling
down per-
forated
bracket**

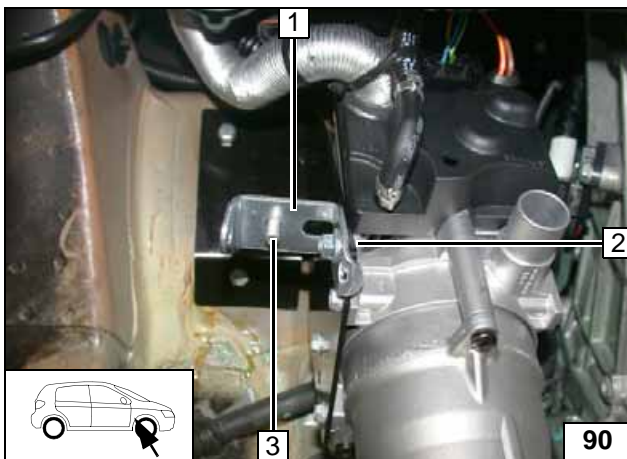

- 1 Perforated bracket
- 2 M6x20 bolt, flanged nut
- 3 M6x16 bolt, insert spring lockwasher from above

**Installing
perforated
bracket**

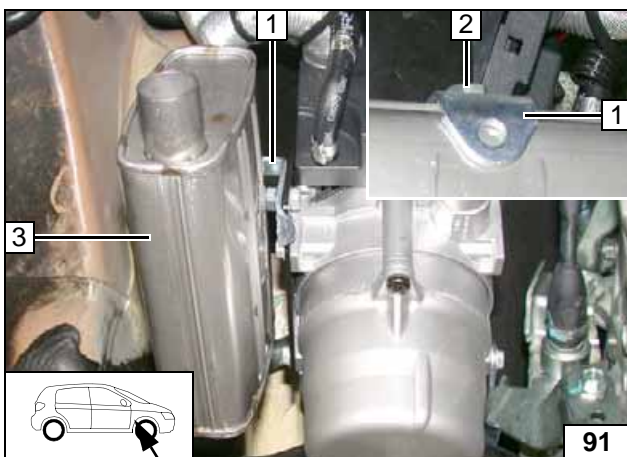

- 1 Perforated bracket
- 2 Tighten M6x16 bolt
- 3 Silencer

**Installing
silencer**

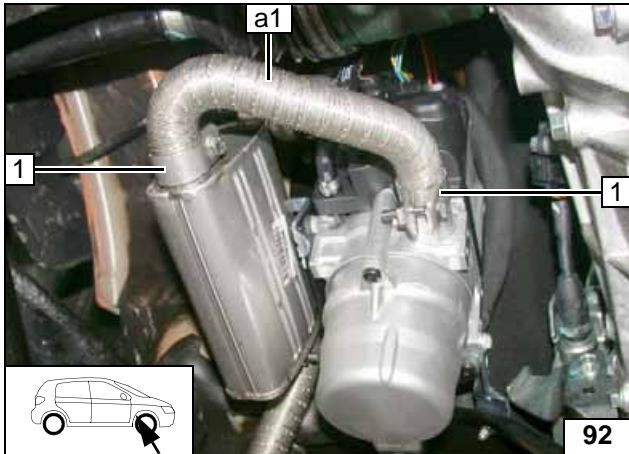
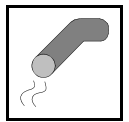

1 Hose clamp [2x]

Installing exhaust pipe a1

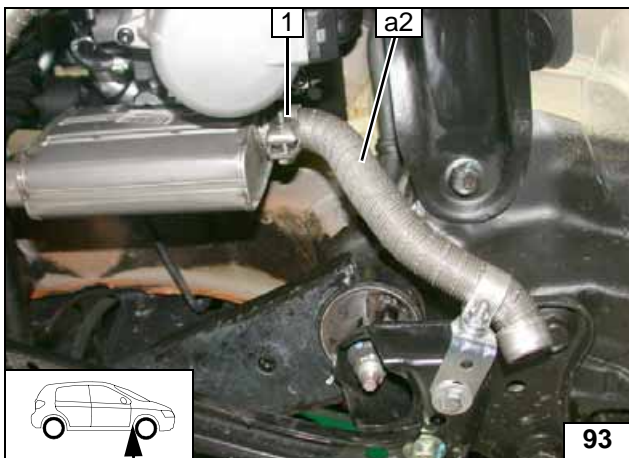

1 Hose clamp

Installing exhaust pipe a2

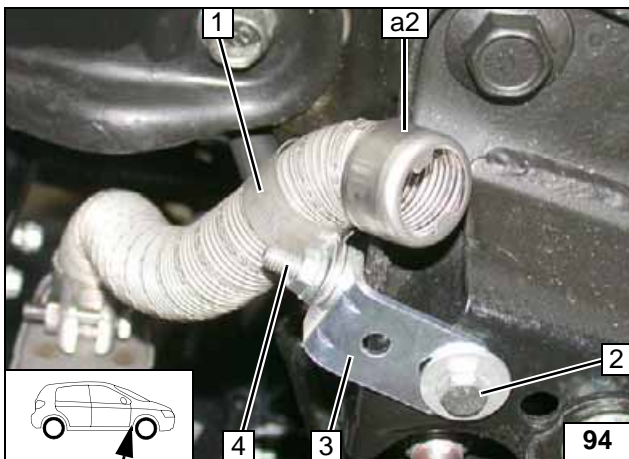

Ensure sufficient distance from adjacent components, correct if necessary.



- 1 P-clamp
- 2 M6x20 bolt, large diameter washer, flanged nut, existing hole
- 3 Angle bracket
- 4 M6x20 bolt, flanged nut

Fastening exhaust pipe a2

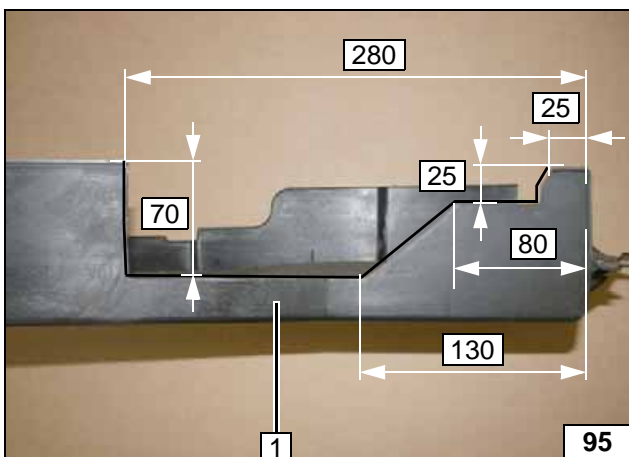

1 Underride protection

Cutting out underride protection

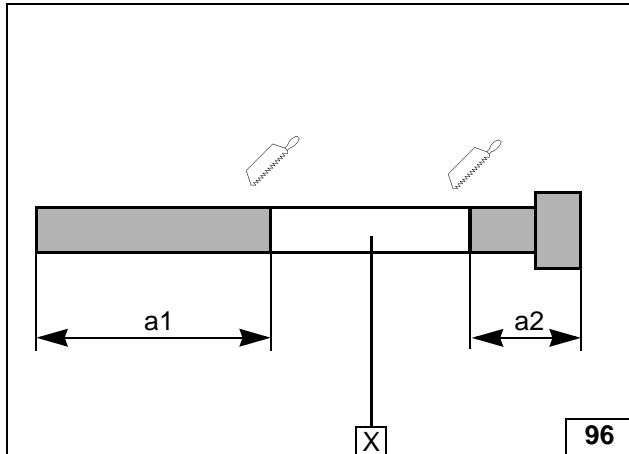
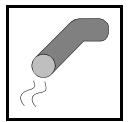

Exhaust for Vehicles with Euro 6 Emission Standard

a1 = 200

a2 = 70

X =

Preparing ex-haust pipe

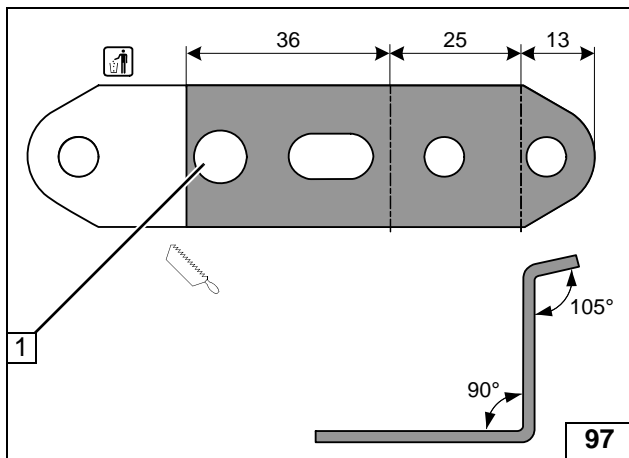

1 Drill out hole to 8.5 mm dia.

Angling down/ adapting perforated bracket

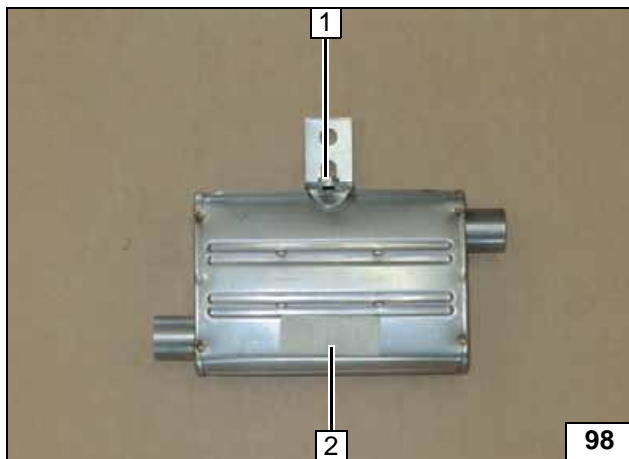

- 1 M6x16 bolt, perforated bracket
- 2 Silencer

Installing perforated bracket

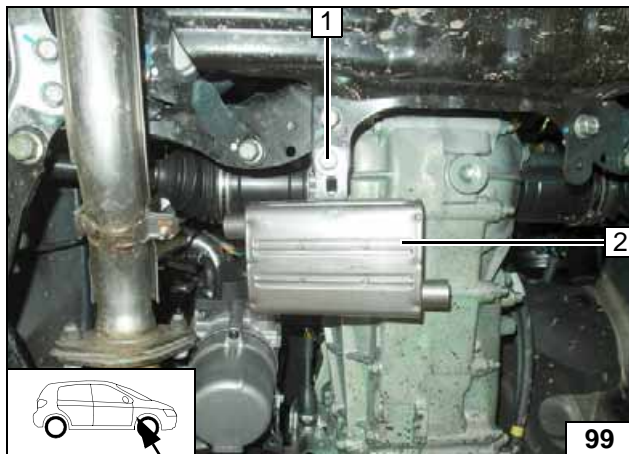

- 1 M8x20 bolt, large diameter washer, original vehicle thread
- 2 Silencer

Installing silencer

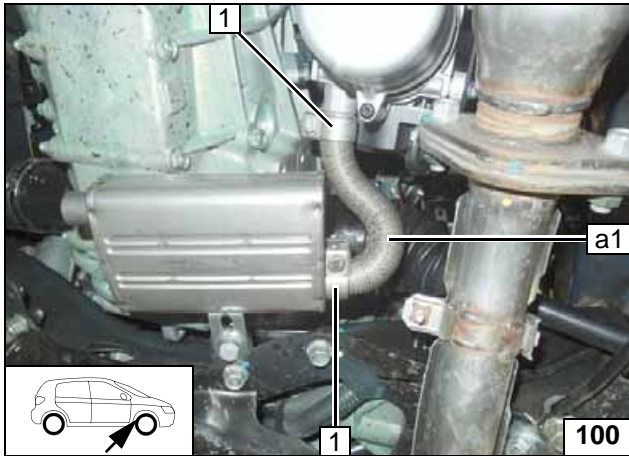
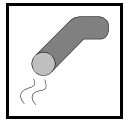

1 Hose clamp [2x]

Installing
exhaust
pipe a1

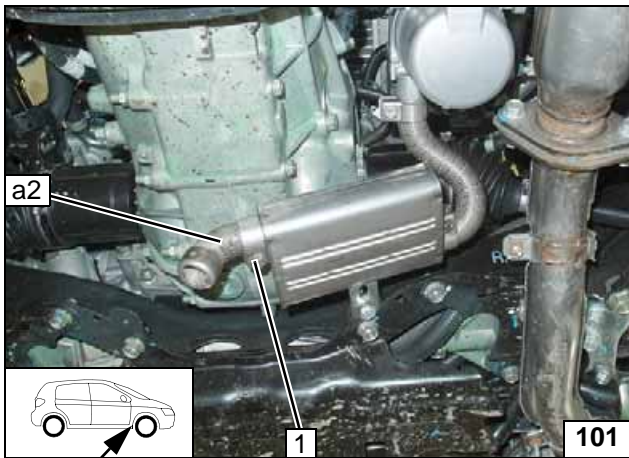

1 Hose clamp



Installing
exhaust
pipe a2



Final Work

WARNING!

Reassemble the components in reverse order. Check all hoses, clamps and all electrical connections for firm seating. Insulate and tie back loose lines.

Only use manufacturer-approved coolant. Spray the heater components with anti-corrosion wax (Tectyl 100K).

- **Connect the battery.**
- **Fill and bleed the coolant circuit according to the vehicle manufacturer's specifications.**
- **Program MultiControl CAR, teach Telestart transmitter.**
- **Make settings on the A/C control panel according to the 'operating instructions'.**
- **Place the 'Switch off parking heater before refuelling' caution label near the filler neck.**
- **For initial startup and function check, please see installation instructions.**

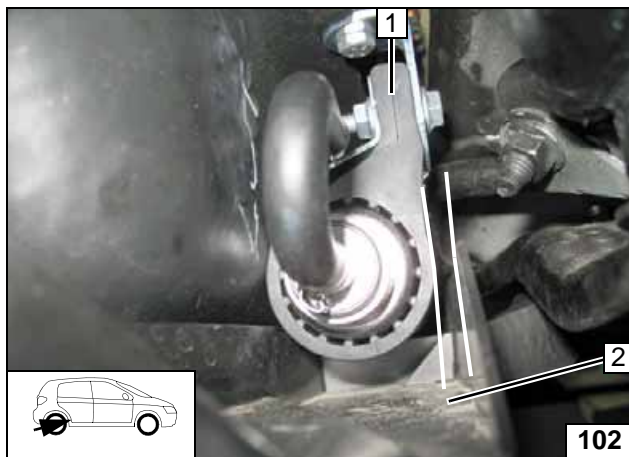

Install underside protection **2**.
Ensure sufficient distance (at least 5 mm)
from metering pump mount **1** to underside
protection **2**, correct if necessary.

**Aligning
mounting
of meter-
ing pump**

Webasto Thermo & Comfort SE
Postfach 1410
82199 Gilching
Germany
Internet: www.webasto.com
Technical Extranet:
<http://dealers.webasto.com>

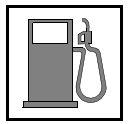

Template for Fuel Standpipe Version 1

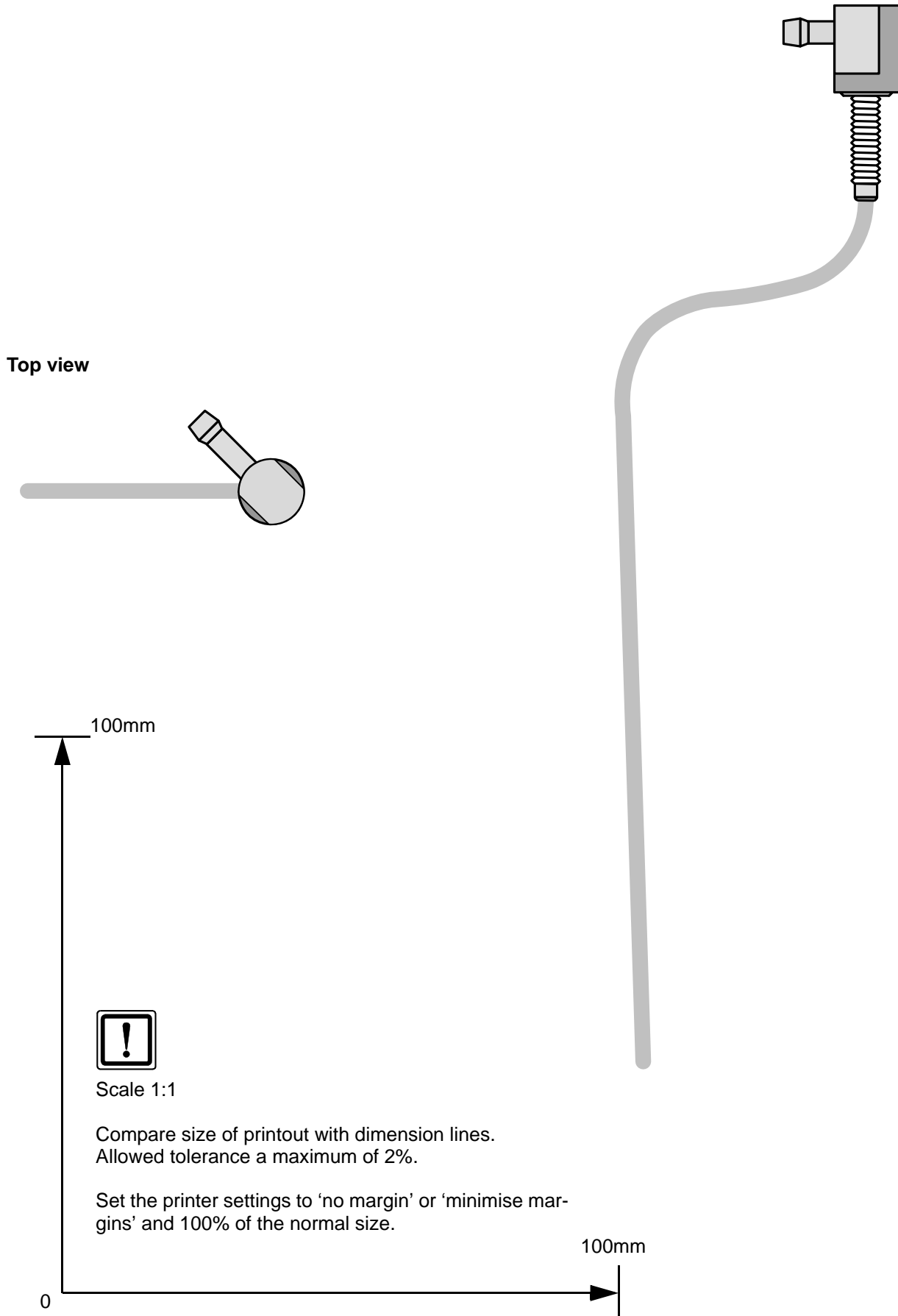

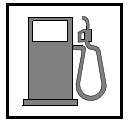

Template for Fuel Standpipe Version 2

Top view

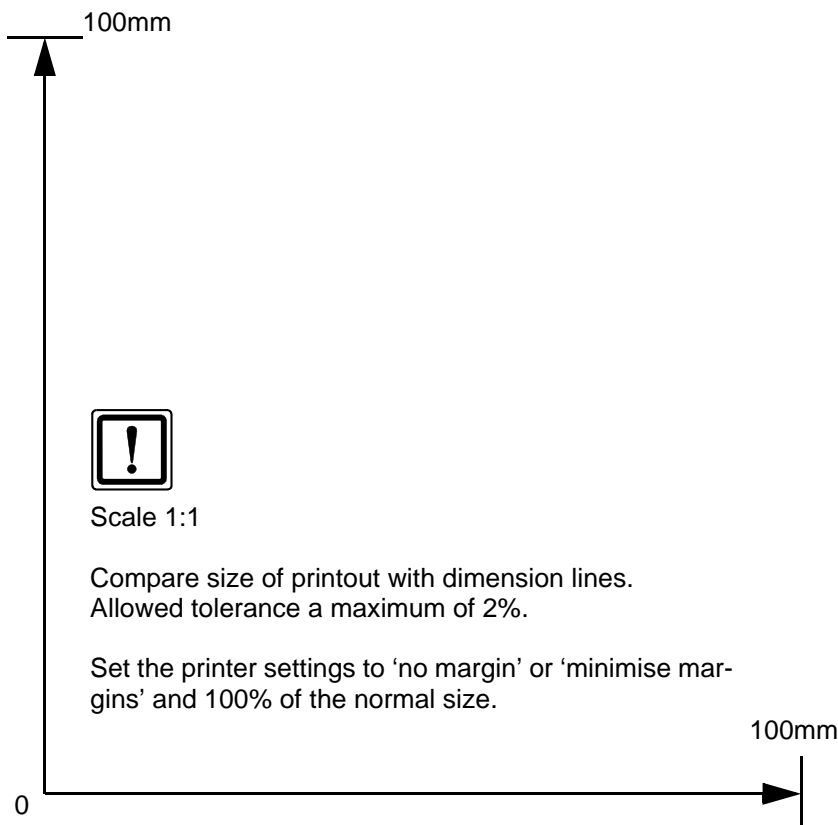
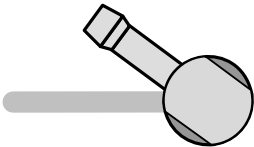

Operating Instructions for 1-Zone Automatic Air-Conditioning

Please remove page and add to the vehicle operating instructions.

Note:

We recommend matching the heating time to the driving time.

Heating time = driving time

Example:

For a driving time of approx. 20 min. (in one direction), we recommend not exceeding a switch-on time of 20 min.

Passenger compartment monitoring, if installed, must be deactivated in addition to the vehicle settings for the heating operation.

For instructions on deactivation, please refer to the operating instructions of the vehicle.

Before parking the vehicle, make the following settings:

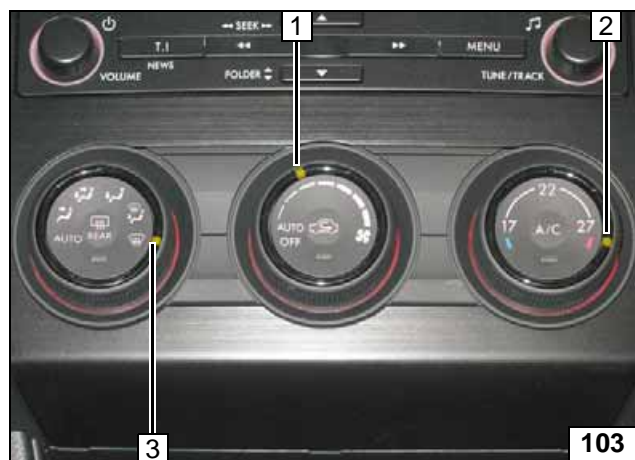

- 1 Set fan to level '2', or max. '3'
- 2 Temperature to 'max.'
- 3 Air outlet to windscreen

A/C control panel

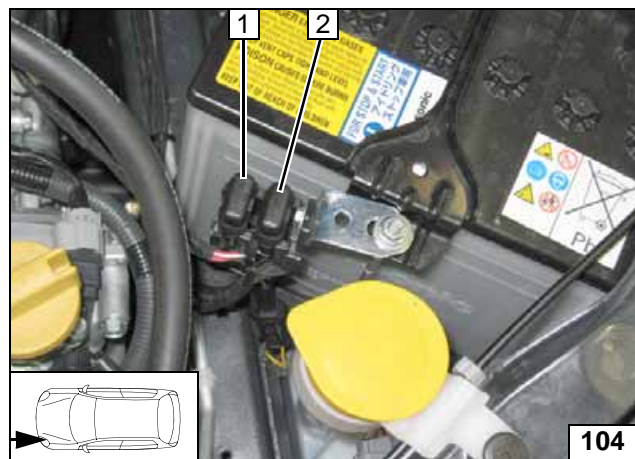

- 1 20A heater fuse F1
- 2 30A passenger compartment main fuse F2

Engine compartment fuses

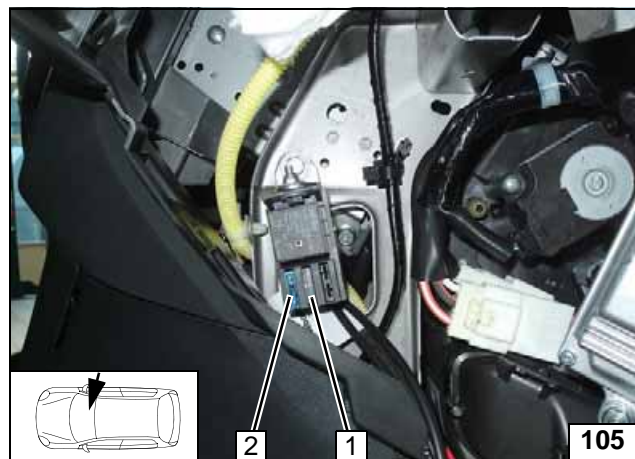

- 1 1A heater control fuse F3
- 2 15A fan fuse F4

Passenger compartment fuses



Operating Instructions for 2-Zone Automatic Air-Conditioning

Please remove page and add to the vehicle operating instructions.

Note:

We recommend matching the heating time to the driving time.
Heating time = driving time

Example:

For a driving time of approx. 20 min. (in one direction), we recommend not exceeding a switch-on time of 20 min.

Passenger compartment monitoring, if installed, must be deactivated in addition to the vehicle settings for the heating operation.

For instructions on deactivation, please refer to the operating instructions of the vehicle.

Before parking the vehicle, make the following settings:



- 1 Air outlet to windscreen
- 2 Set fan to level '2'
- 3 Set temperature on both sides to 'HI'

A/C control panel

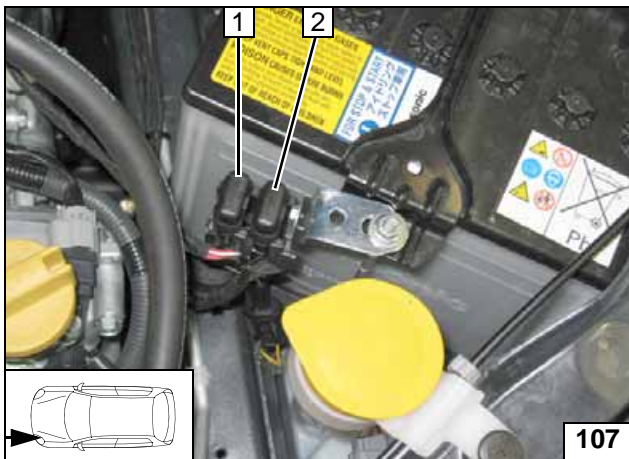

- 1 20A heater fuse F1
- 2 30A passenger compartment main fuse F2

Engine compartment fuses

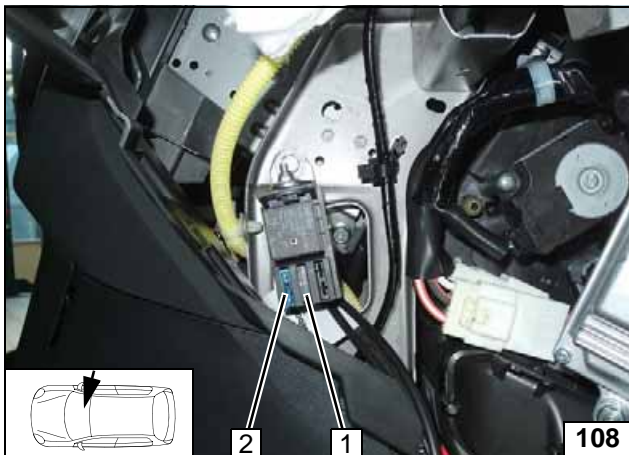

- 1 1A heater control fuse F3
- 2 15A fan fuse F4

Passenger compartment fuses

