

Water Heater

Thermo Top Evo Parking Heater



Installation Documentation

Kia cee'd

Validity

Manufacturer	Model	Type	EG-BE-No. / ABE
Kia	cee'd	U2	e4 * 2007 / 46 * 0496 * ...

Motorisation	Fuel	Transmission type	Output in kW	Displacement in cm ³	Engine code
1.4 CRDi	Diesel	6-speed SG	66	1396	D4FC
1.6 CRDi	Diesel	6-speed SG	94	1582	D4FB
1.6 CRDi	Diesel	AG	94	1582	D4FB

SG = manual transmission

AG = automatic transmission

From Model Year 2012

Left-hand drive vehicle

Verified equipment variants: Manual / automatic air-conditioning system

Front fog lights

Start-Stop

Alarm system without passenger compartment monitoring

Headlight washer system

Daytime running lights

Total installation time: approx. 6.5 hours

Table of Contents

Validity	1	Preparing Installation Location	18
Necessary Components	2	Exhaust Gas	19
Installation Overview	2	Preparing Heater	21
Information on Total Installation Time	2	Installing Heater	22
Information on Operating and Installation Instructions	3	Fuel	25
Information on Validity	4	Coolant Circuit	28
Technical Information	4	Combustion Air	34
Explanatory Notes on Document	4	Final Work	35
Preliminary Work	5	Operating Instructions for Manual Air-Conditioning	36
Heater Installation Location	5	Operating Instructions for Automatic Air-Conditioning	37
Preparing Electrical System	6		
Electrical System	8		
Instrument Panel Dismantling Instructions	9		
Fan Controller for Manual Air-Conditioning	11		
Fan Controller for Automatic Air-Conditioning	13		
Digital Timer	16		
Remote Option (Telestart)	16		
Thermo Call Option	17		

Necessary Components

- Basic delivery scope of *Thermo Top Evo* in accordance with price list
- Installation kit for Kia cee'd 2012 Diesel: **1318687C**
- Heater control in accordance with price list and upon consultation with end customer
- In case of digital timer installation: Digital timer wire extension: **1319724_**
- In case of Telestart, indicator lamp in accordance with price list and in consultation with end customer

Installation instructions:

- Arrange for the vehicle to be delivered with the tank only about ¼ full.
- The installation location of the push button in case of Telestart or Thermo Call should be confirmed with the end customer.
- Depending on the available space and manufacturer's instructions, we recommend the use of a vehicle battery with more electrical capacity.

Installation Overview

Legend:

1. Heater
2. Engine compartment fuse holder
3. Passenger compartment relay and fuse holder
4. Circulating pump
5. Digital timer
6. Metering pump

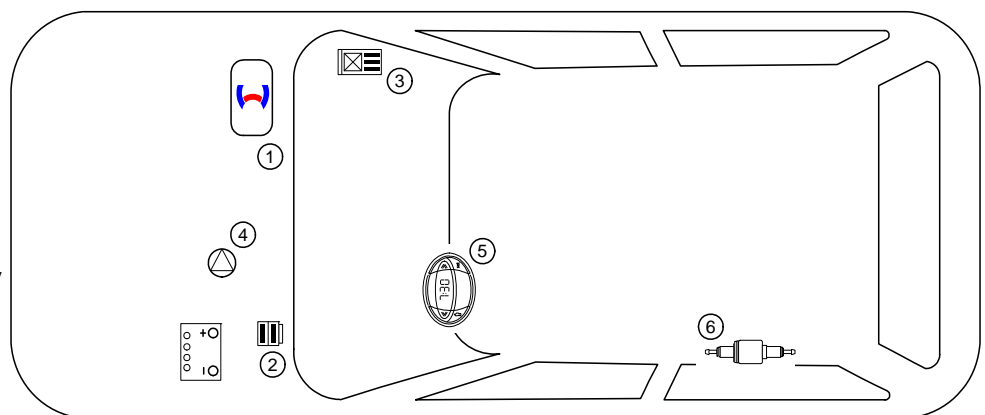

Information on Total Installation Time

The total installation time includes the time needed for mounting and demounting of the vehicle-specific components, the heater specific installation time and all other times required for the system integration and initial start-up of the heater.

The total installation time may vary for vehicle equipment other than provided.

Information on Operating and Installation Instructions

1 Important information (not complete)

1.1 Installation and repair



The improper installation or repair of Webasto heating and cooling systems can cause fire or the leakage of deadly carbon monoxide, leading to serious injury or death.



To install and repair Webasto heating and cooling systems you need to have completed a special company training course and have the appropriate technical documentation, special tools and special equipment.



Installation and repair may ONLY be carried out by persons trained and certified in a Webasto training course. NEVER try to install or repair Webasto heating or cooling systems if you have not completed a Webasto training course, you do not have the necessary technical skills and you do not have the technical documentation, tools and equipment available to ensure that you can complete the installation and repair work properly.

Only use genuine Webasto parts. See the Webasto air and water heaters accessories catalogue for this purpose.

1.2 Operation

To ensure safe operation, we recommend having the heater checked every two years by an authorised Webasto dealer, especially when used over a long period and/or under extreme environmental conditions.

Do not operate the heater in closed rooms due to the danger of poisoning and suffocation.

Always switch off the heater before refuelling.

The heater may only be used with the prescribed fuel diesel (DIN EN 590) or petrol (DIN EN 228).

The heater may not be cleaned with a high-pressure cleaner.

1.3 Please note

ALWAYS follow all Webasto installation and operating instructions and observe all warnings.

To become familiar with and understand all functions and properties of the heater, the operating instructions must be read carefully and observed at all times.

For proper, safe installation and repair work, the installation instructions with all warnings and safety information must be carefully read and observed at all times. Please always contact a workshop authorised by Webasto for all installation and repair work.

Important

Webasto shall assume no liability for defects, damage and injuries resulting from a failure to observe the installation, repair and operating instructions of the information contained in them.

This liability exclusion particularly applies to improper installations and repairs, installations and repairs by untrained persons or in the case of a failure to use genuine spare parts.

The liability due to culpable disregard to life, limb or health and due to damage or injuries caused by a wilful or reckless breach of duty remain unaffected, as does the obligatory product liability.

Installation should be carried out according to the general, standard rules of technology. Unless specified otherwise, fasten hoses, lines and wiring harnesses to original vehicle lines and wiring harnesses using cable ties. Insulate loose wire ends and tie back. Connectors on electronic components must audibly snap into place during assembly.

Sharp edges should be fitted with rub protection. Spray unfinished body areas, e.g. drilled holes, with anti-corrosion wax (Tectyl 100K, Order No. 111329).

Observe the instructions and guidelines of the respective vehicle manufacturer for demounting and mounting vehicle specific components!

The initial startup is to be executed with the Webasto Thermo Test Diagnosis.

When installing a programmable control module (e.g. a PWM Gateway), the corresponding settings must be checked or adjusted.

2 Statutory regulations governing installation

Guidelines	Thermo Top Evo
Heating Directive ECE R122	E1 00 0258
EMC Directive ECE R10	E1 04 5627

Note

The regulations of these guidelines are binding in the scope of the Directive 70/156/EEC and/or 2007/46/EC (for new vehicle models from 29/04/2009) and should also be observed in countries in which there are no special regulations.

Important

Failure to follow the installation instructions will result in the invalidation of the type approval for the heater and therefore invalidation of the general **homologation of the vehicle**.

Note

The heater is licensed in accordance with paragraph 19, section 3, No. 2b of the StVZO (German Road Traffic Licensing Authority).

2.1 Excerpt from ECE regulation 122 (heating system) paragraph 5 for the installation of the heater

Beginning of excerpt.

ANNEX VII

REQUIREMENTS FOR COMBUSTION HEATERS AND THEIR INSTALLATION

1. GENERAL REQUIREMENTS

1.7.1. A clearly visible tell-tale in the operator's field of view shall inform when the combustion heater is switched on or off.

2. VEHICLE INSTALLATION REQUIREMENTS

2.1. Scope

2.1.1. Subject to paragraph 2.1.2. combustion heaters shall be installed according to the requirements of this Annex.

2.1.2. Vehicles of category O having liquid fuel heaters are deemed to comply with the requirements of this Annex.

2.2. Positioning of heater

2.2.1. Body sections and any other components in the vicinity of the heater must be protected from excessive heat and the possibility of fuel or oil contamination.

2.2.2. The combustion heater shall not constitute a risk of fire, even in the case of overheating. This requirement shall be deemed to be fulfilled if the installation ensures an adequate distance to all parts and suitable ventilation, by the use of fire resistant materials or by the use of heat shields.

2.2.3. In the case of M2 and M3 vehicles, the heater must not be positioned in the passenger compartment. However, an installation in an effectively sealed envelope which also complies with the conditions in paragraph 2.2.2 may be used.

2.2.4. The label referred to in paragraph 1.4 or a duplicate, must be positioned so that it can be easily read when the heater is installed in the vehicle.

2.2.5. Every reasonable precaution should be taken in positioning the heater to minimise the risk of injury and damage to personal property.

2.3. Fuel supply

2.3.1. The fuel filler must not be situated in the passenger compartment and must be provided with an effective cap to prevent fuel spillage.

2.3.2. In the case of liquid fuel heaters, where a supply separate to that of the vehicle is provided, the type of fuel and its filler point must be clearly labelled.

2.3.3. A notice, indicating that the heater must be shut down before refuelling, must be affixed to the fuelling point. In addition a suitable instruction must be included in the manufacturer's operating manual.

2.4. Exhaust system

2.4.1. The exhaust outlet must be located so as to prevent emissions from entering the vehicle through ventilators, heated air inlets or opening windows.

2.5. Combustion air inlet

2.5.1. The air for the combustion chamber of the heater must not be drawn from the passenger compartment of the vehicle.

2.5.2. The air inlet must be so positioned or guarded that blocking by rubbish or luggage is unlikely.

2.6. Heating air inlet

2.6.1. The heating air supply may be fresh or recirculated air and must be drawn from a clean area not likely to be contaminated by exhaust fumes emitted either by the propulsion engine, the combustion heater or any other vehicle source.

2.6.2. The inlet duct must be protected by mesh or other suitable means.

2.7. Heating air outlet

2.7.1. Any ducting used to route the hot air through the vehicle must be so positioned or protected that no injury or damage could be caused if it were to be touched.

2.7.2. The air outlet must be so positioned or guarded that blocking by rubbish or luggage is unlikely.

End of excerpt.

In multilingual versions the German language is binding.

Kia cee'd

Information on Validity

This installation documentation applies to Kia cee'd Diesel vehicles - for validity, see page 1 - from model year 2012 and later, assuming technical modifications to the vehicle do not affect installation, any liability claims excluded. Depending on the vehicle version and equipment, modifications may be necessary during installation with respect to this "installation documentation".

Vehicle and engine types, equipment variants and other specifications not listed in this installation documentation have not been tested. However, installation according to this installation documentation may be possible.

Technical Information

Special Tools

- Hose clamp pliers for self-clamping hose clamps
- Hose clamp pliers for Clic hose clamps of type W
- Automatic wire stripper 0.2 - 6mm²
- Crimping pliers for cable lug / tab connector 0.5 - 6mm²
- Torque wrench for 2.0 - 10 Nm
- Hose clamping pliers
- Metric thread-setter kit
- Deep-hole marker
- Webasto Thermo Test diagnosis with current software

Dimensions

- All dimensions are in mm.













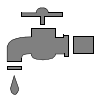

Tightening torque values

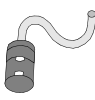
- Tightening torque values of 5x13 heater bolts and 5x11 heater stud bolts = 8Nm.
- Tightening torque value of 5x15 water connection piece retaining plate bolt = 7Nm.
- Tighten other bolt connections in accordance with manufacturer's instructions or in accordance with state-of-the-art-technology.

Explanatory Notes on Document

You will find an identification mark on the outside top right corner of the page in question to provide you with a quick overview of the individual working steps.

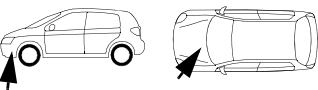
Special features are highlighted using the following symbols:

Mechanical System		Specific risk of injury or fatal accidents.	
Electrical System		Specific risk due to electrical voltage.	
Coolant Circuit		Specific risk of damage to components.	
Combustion Air		Specific risk of fire and explosion.	
Fuel		Reference to general installation instructions of the Webasto components or to the manufacturer's vehicle-specific documents.	
Exhaust Gas		Reference to a special technical feature.	
Software		The arrow in the vehicle icon indicates the position on the vehicle and the viewing angle.	
		Tightening torque according to the manufacturer's vehicle-specific documents.	

Kia cee'd

Preliminary Work

Vehicle

- Open the fuel tank cap.
- Ventilate the fuel tank.
- Close the fuel tank cap again.
- Depressurise the cooling system.
- Remove the engine design cover.
- Disconnect the battery and remove it completely, including the carrier.
- Remove the engine control unit.
- Remove the air filter box completely, including the intake hose.
- Remove the lateral instrument panel trim on the right.
- Remove the glove box.
- Remove the glove box frame.
- Remove the lower instrument panel trim on the right (only with automatic air-conditioning).
- Remove the A/C control panel (only with automatic air-conditioning).
- Remove the front underride protection.
- Remove the lateral cover of fuel lines on the underbody.

Heater

- Remove years that do not apply from the type and duplicate label.
- Attach the duplicate label (type label) visibly in the appropriate place in the engine compartment.

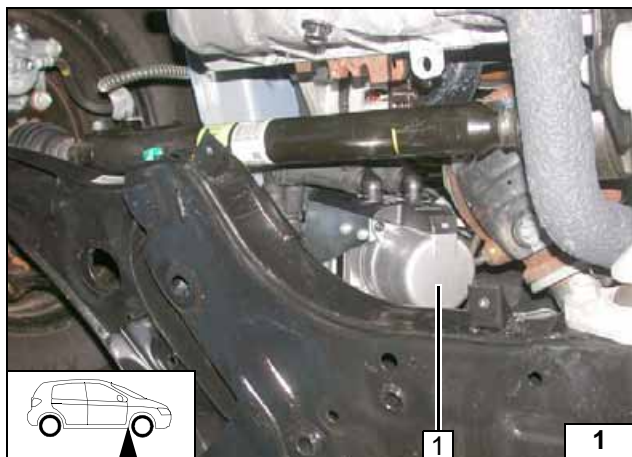

Heater Installation Location

1 Heater

Installation
location

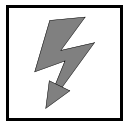

Preparing Electrical System

Manual air-conditioning

Wire sections retain their numbering throughout the entire document.

Produce all following electrical connections as shown in the wiring diagram.

- ① Red (rt) wire of fan wiring harness
- ② Black (sw) wire of fan wiring harness

Cutting to length/ assigning wires

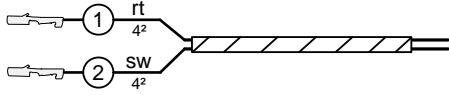

2

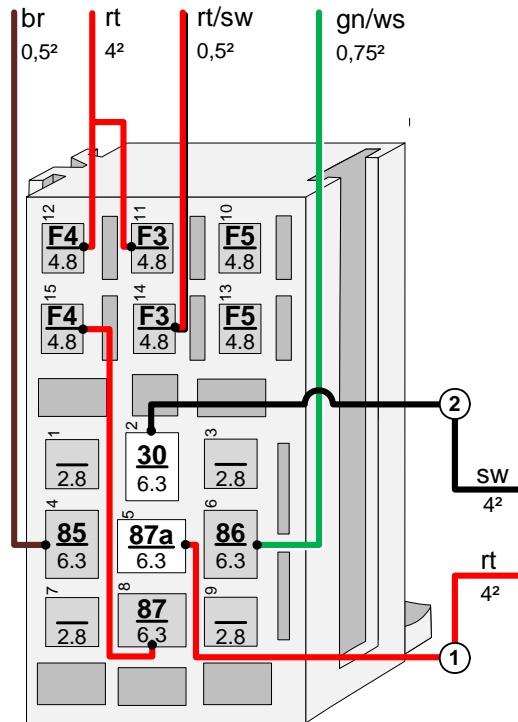

Connecting wires to passenger compartment relay and fuse holder

3

Automatic air-conditioning

Discard sections X.

- ① Red (rt) wire of fan wiring harness
- ② Black (sw) wire of fan wiring harness

Cutting to length/ assigning wires

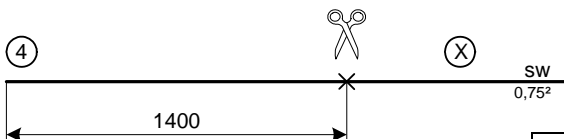
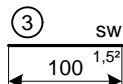
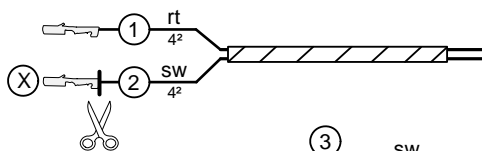

4



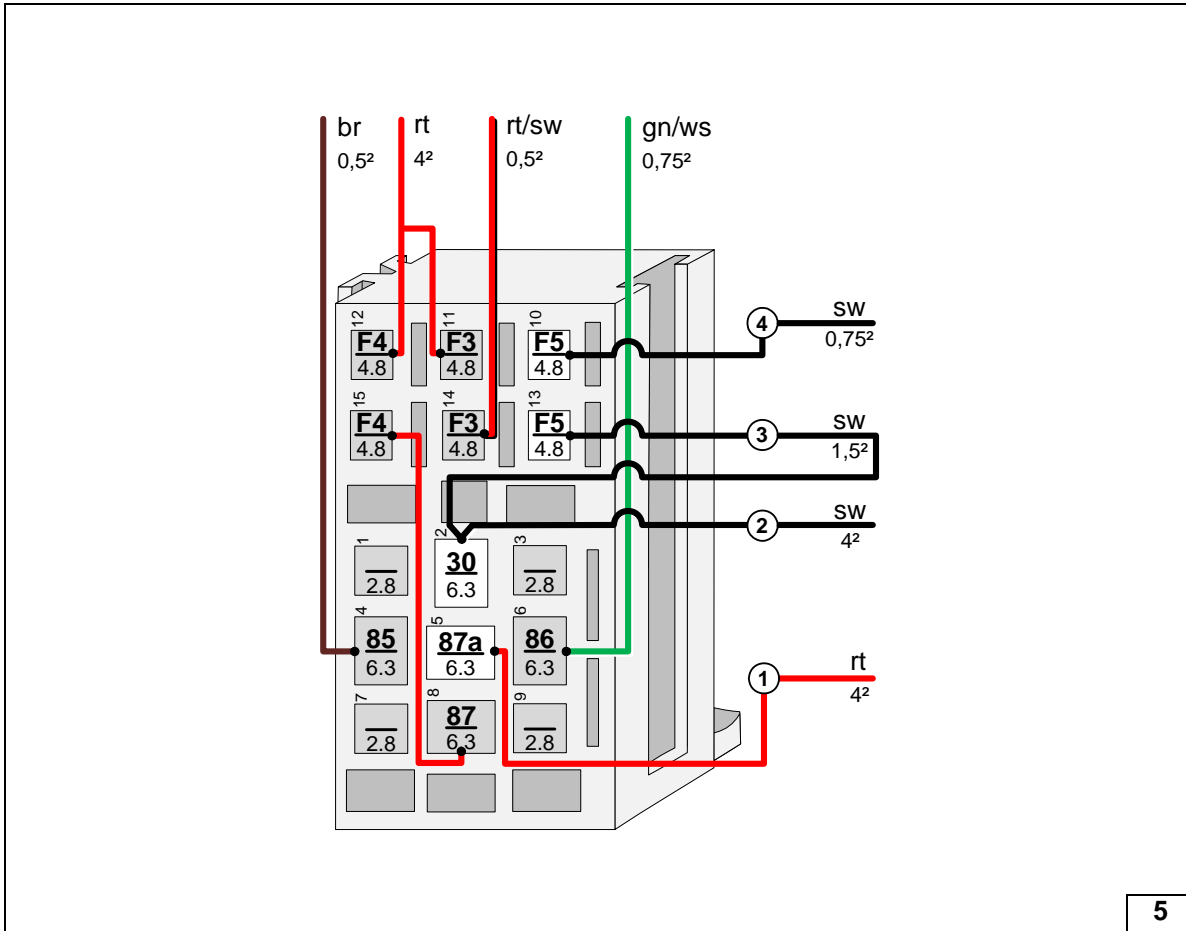
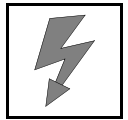

Connecting wires to passenger compartment relay and fuse holder

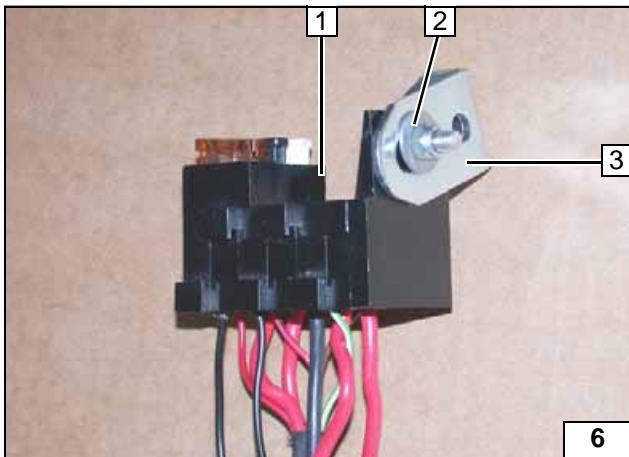

All vehicles

- 1 Passenger compartment relay and fuse holder
- 2 M5x16 bolt, washer [2x], nut
- 3 Angle bracket



Premounting passenger compartment relay and fuse holder

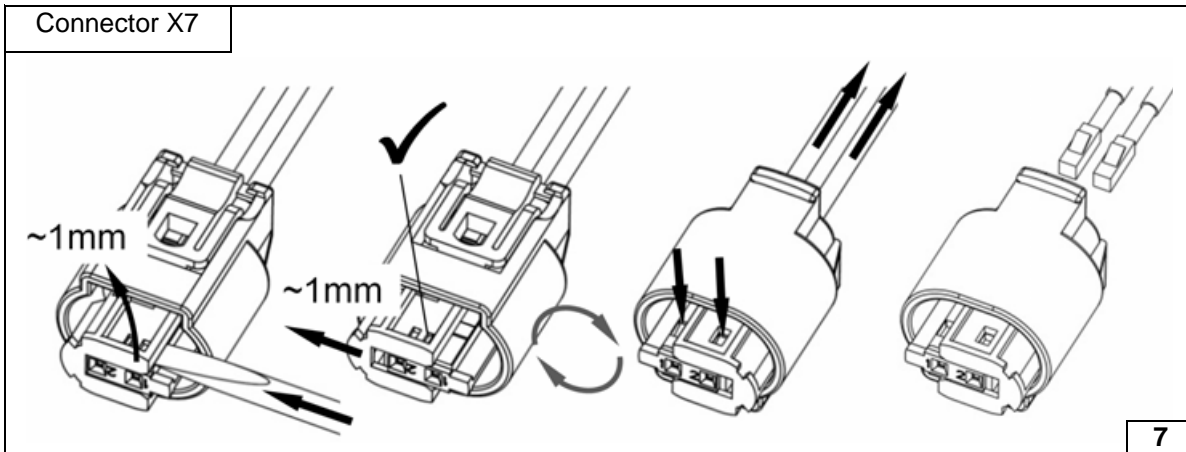

Dismantling metering pump connector



Electrical System

Wiring harness pass through

- 1 Protective rubber plug
- 2 Wiring harnesses of heater and heater control

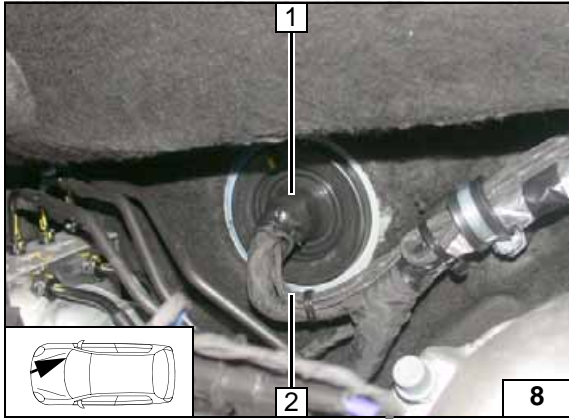

Wiring harness routing

- Remove wiring harness clip [2x] at position 2.
- 1 Wiring harnesses of heater and heater control
 - 2 M6x16 bolt, spring lockwasher, 25mm dia. rubber-coated p-clamp, M6x30 spacer nut, original vehicle stud bolt [2x each]

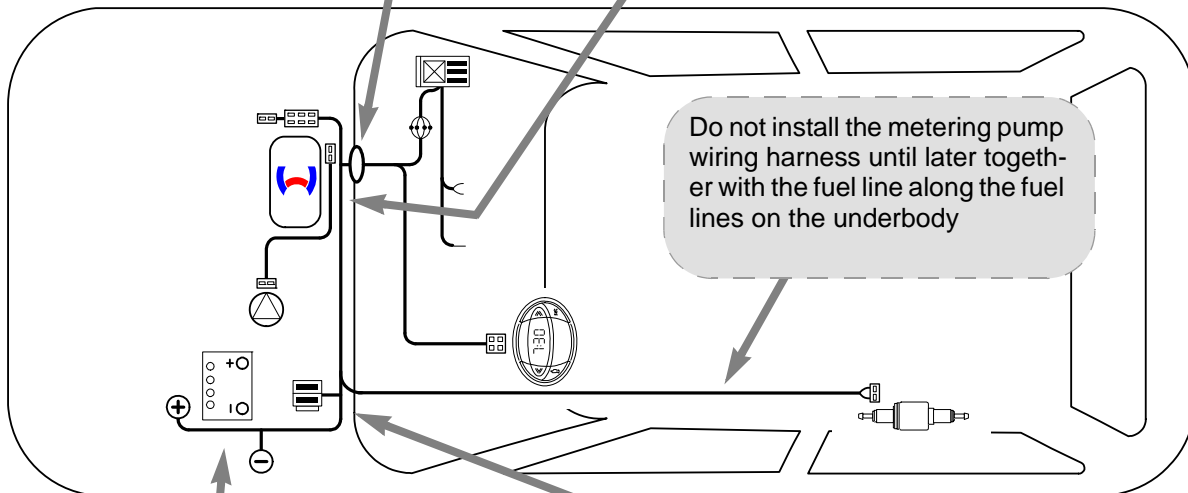
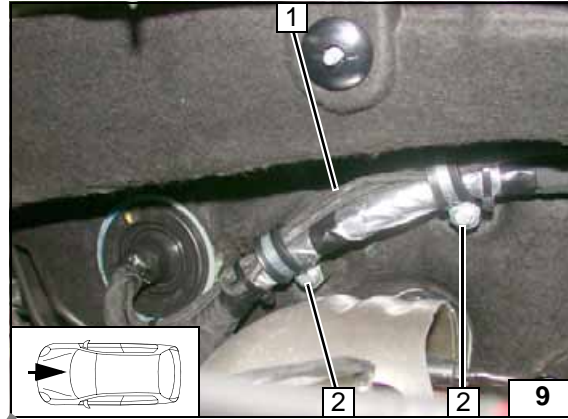

Wiring harness routing diagram

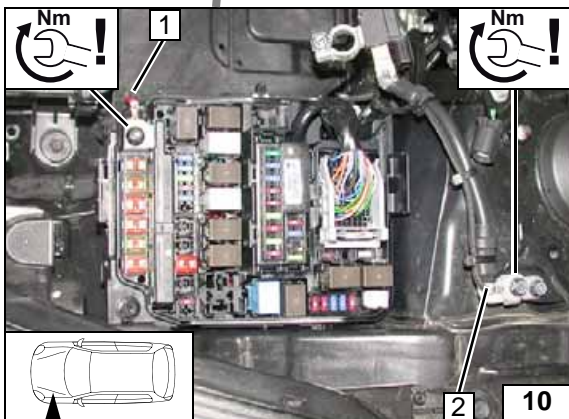

Positive and earth wire

- 1 Positive wire on original vehicle positive distributor
- 2 Earth wire on original vehicle earth support point

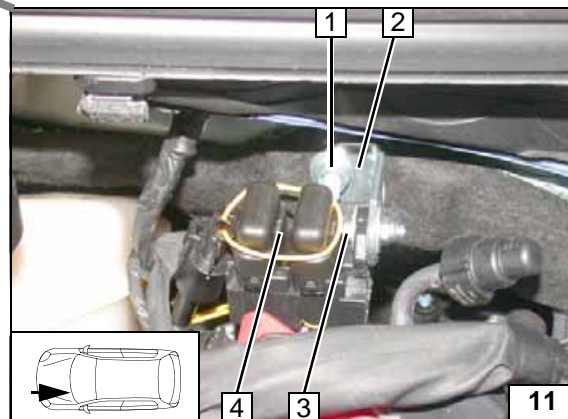

Engine compartment fuse holder

- Remove plastic nut at position 1.
- 1 M6 flanged nut, original vehicle stud bolt
 - 2 Angle bracket
 - 3 M5x16 bolt, washer [2x], retaining plate for fuse holder, nut
 - 4 Fuses F1-2



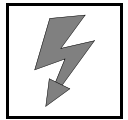

Instrument Panel Dismantling Instructions

Removing the glove box frame/mounting

- 1 Remove bolt [2x]
- 2 Remove and discard bolt

Removing glove box frame / mounting

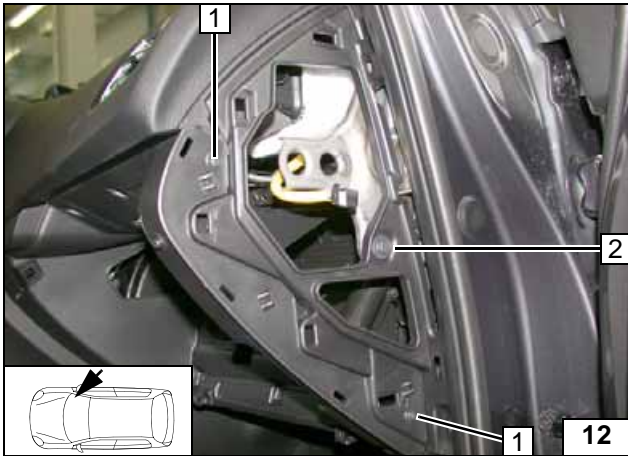

- 1 Remove bolt [8x]

Removing glove box frame / mounting

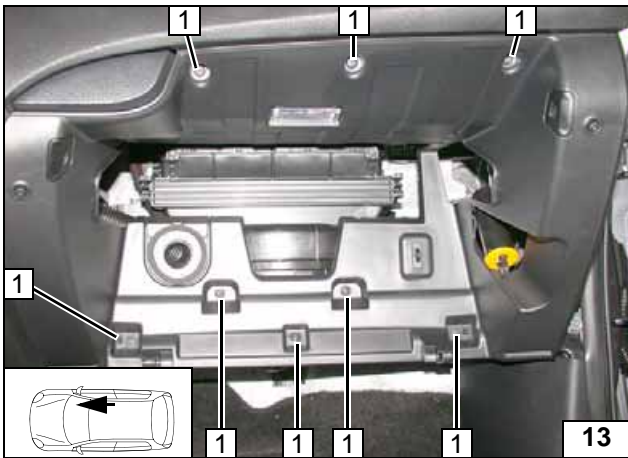

Removing the A/C control panel

Only in case of automatic air-conditioning

- 1 Remove bolt [2x]

Removing A/C control panel frame

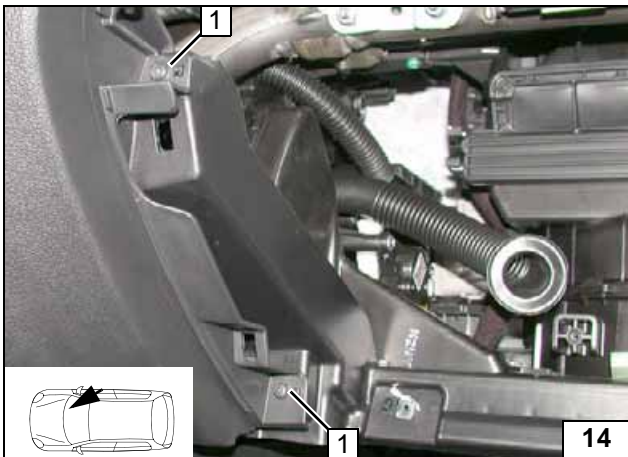

- 1 Remove bolt [3x]

Removing A/C control panel frame

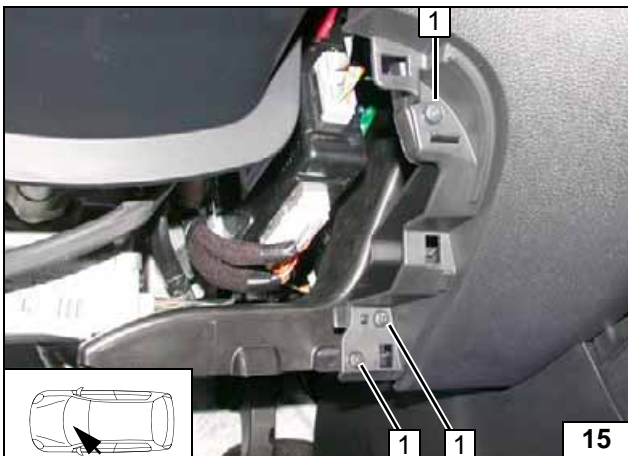

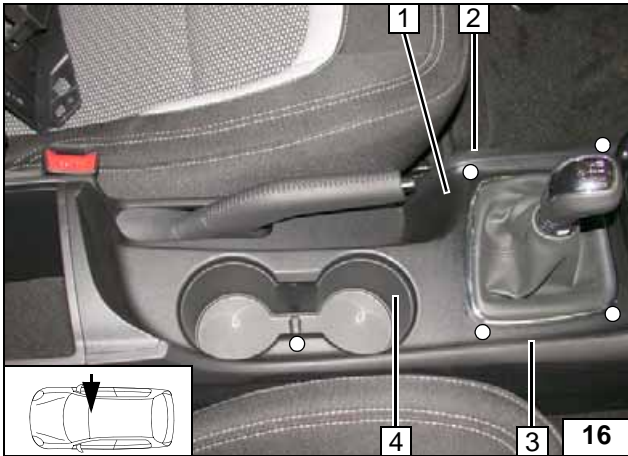

- 1 Loosen gear shifter boot
- 2 Remove left side trim
- 3 Remove right side trim
- 4 Remove the centre console
- Centre console retaining clip [5x]

Removing centre console and side trim on the left and right

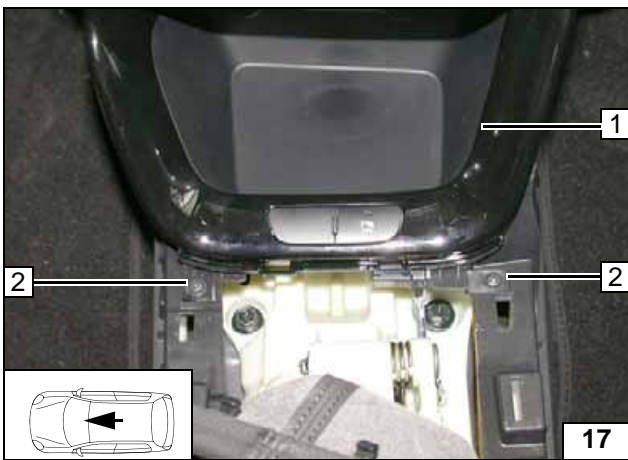

Pull out storage compartment 1 towards the passenger compartment.



- 2 Remove bolts [2x]

Removing storage compartment

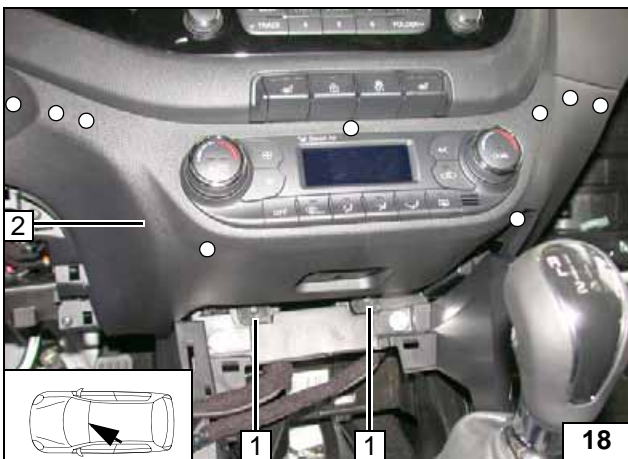

- 1 Remove bolts [2x]
- 2 Remove A/C control panel trim
- A/C control panel retaining clip [9x]

Removing A/C control panel

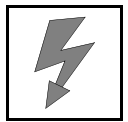

Fan Controller for Manual Air-Conditioning

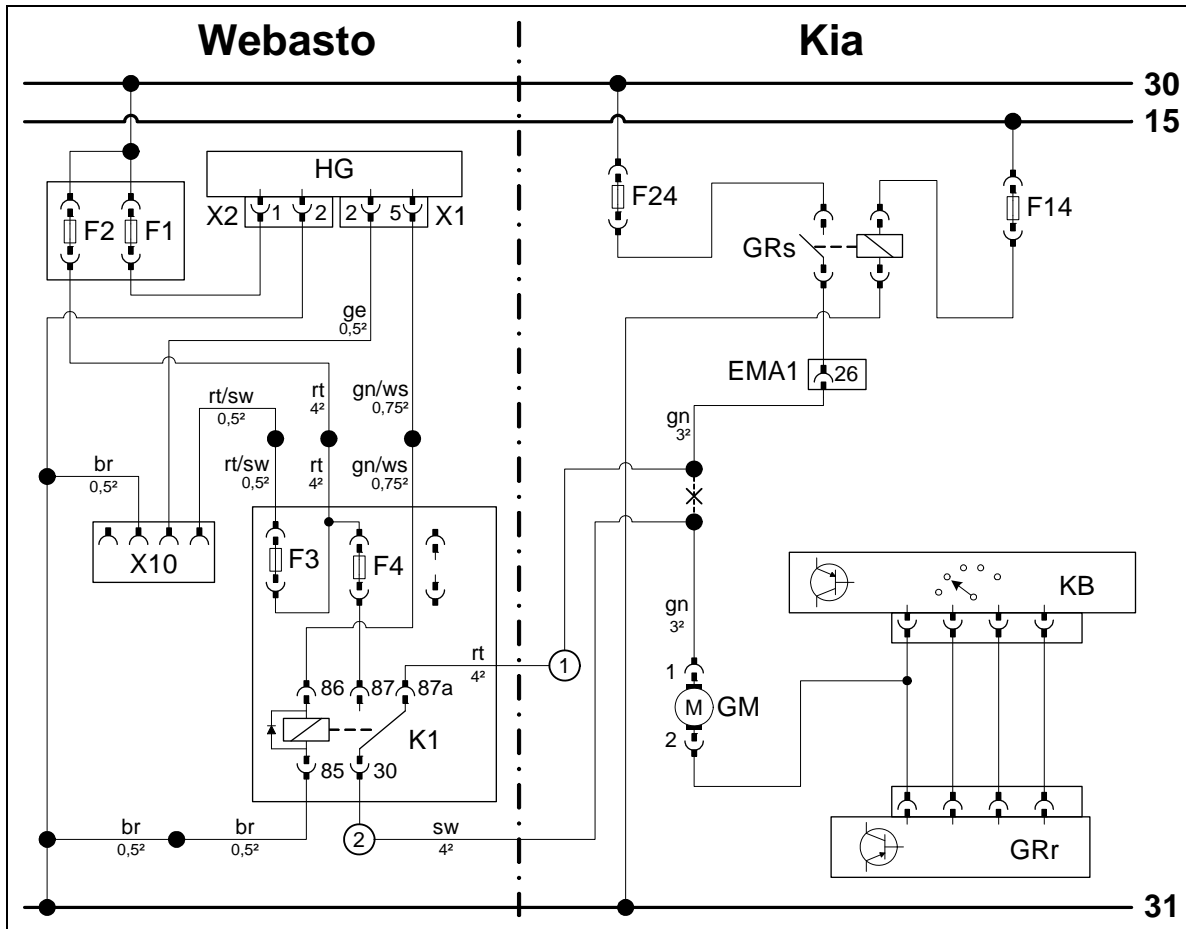

Wiring diagram

Webasto components		Vehicle components		Colours and symbols	
HG	TT-Evo heater	F24	50A fuse	rt	red
X1	6-pin heater connector	F14	7.5A fuse	sw	black
X2	2-pin heater connector	GRs	Fan relay	ge	yellow
F1	20A fuse	EMA1	Connector	gn	green
F2	30A fuse	KB	A/C control panel	br	brown
X10	4-pin connector of heater control	GM	Fan motor	ws	white
F3	1A fuse	GRr	Fan controller		
F4	25A fuse				
K1	Fan relay				
				X	Cutting point
				Wiring colours may vary.	

Legend

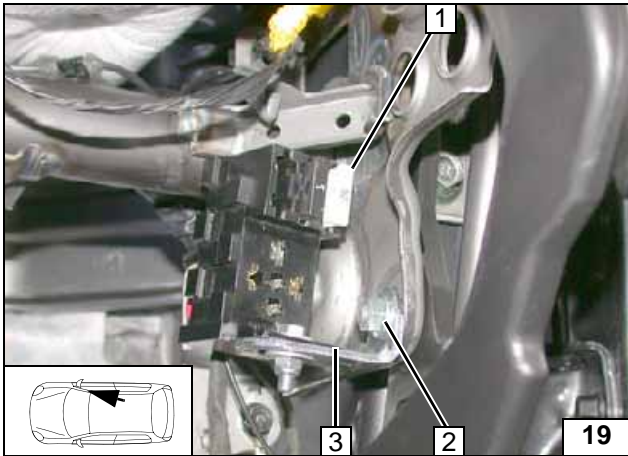
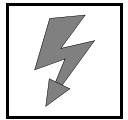

- 1 25A fuse F4
- 2 M6X20 bolt, flanged nut
- 3 Angle bracket

Installing passenger compartment relay and fuse holder

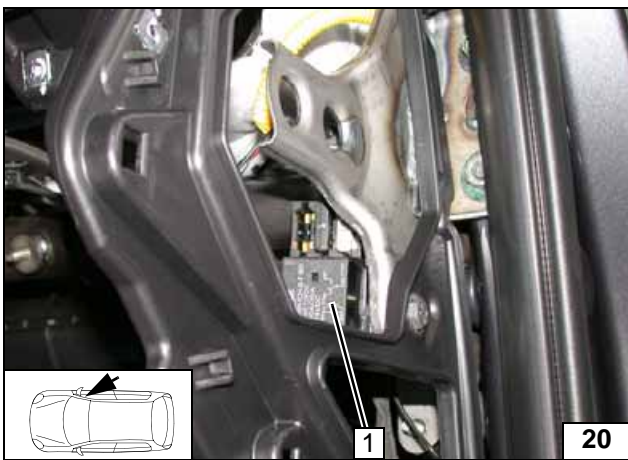

- 1 K1 relay

Attaching relay

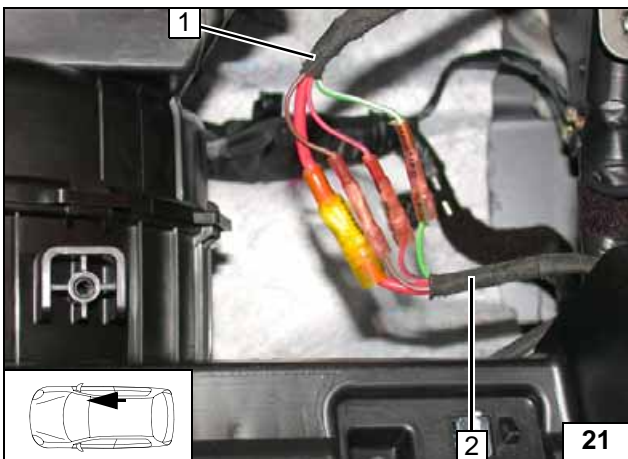

- 1 Wiring harness of passenger compartment relay and fuse holder
- 2 Wiring harness of heater



Connecting same colour wires of wiring harnesses

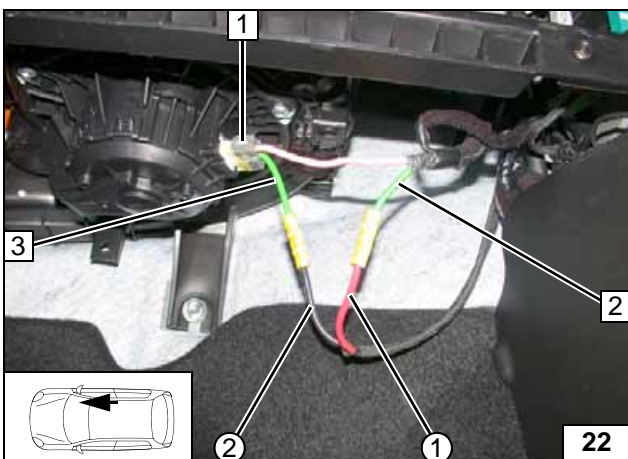

Connection to 2-pin connector 1 from the fan motor.

- 2 Green (gn) wire from fan relay
- 3 Green (gn) wire of connector GM, pin 1
- ① Red (rt) wire of K1/87a, fan wiring harness
- ② Black (sw) wire of K1/30, fan wiring harness



Connecting fan motor

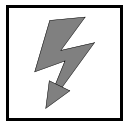

Fan Controller for Automatic Air-Conditioning

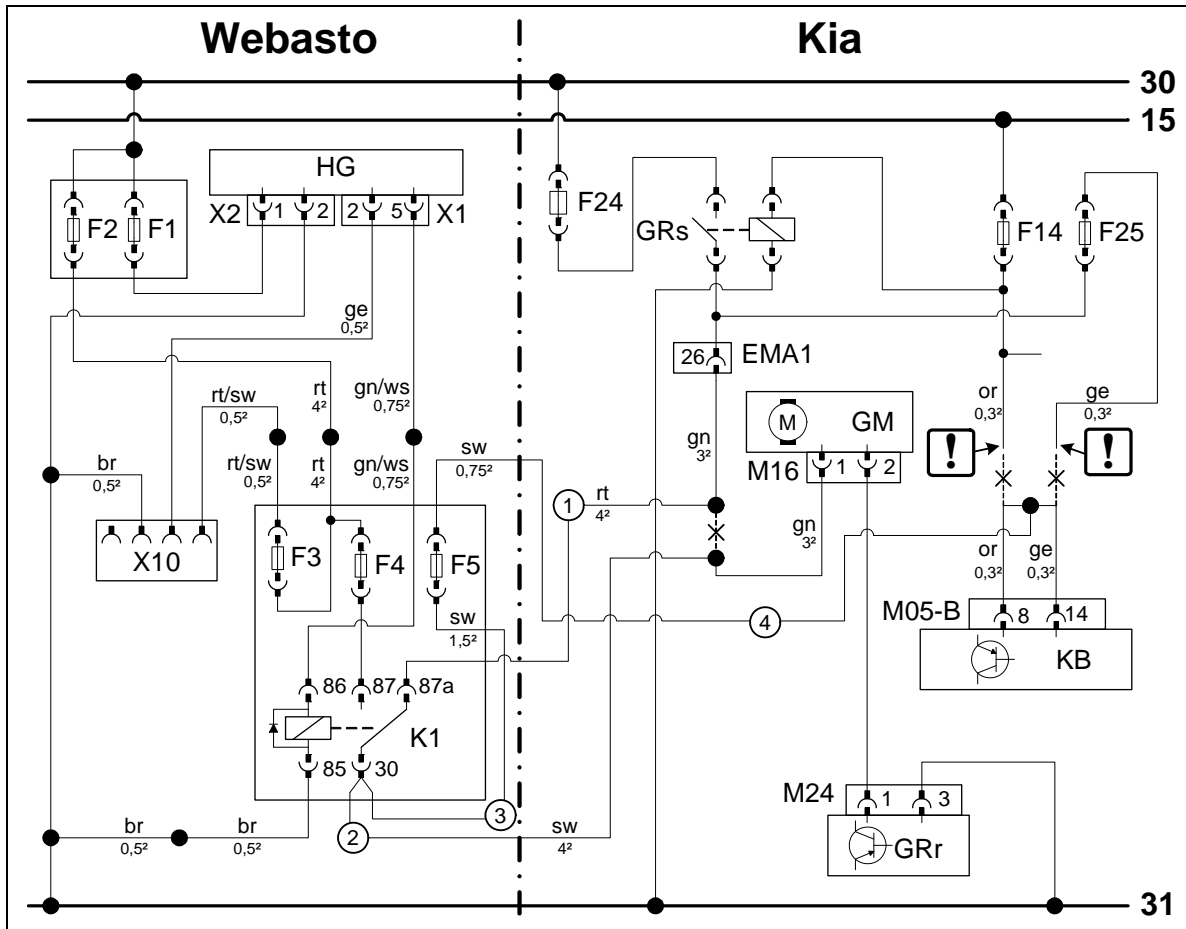

Wiring diagram

Webasto components		Vehicle components		Colours and symbols	
HG	TT-Evo heater	F24	50A fuse	rt	red
X1	6-pin heater connector	F14	7.5A fuse	sw	black
X2	2-pin heater connector	F25	10A fuse	ge	yellow
F1	20A fuse	GRs	Fan relay	gn	green
F2	30A fuse	EMA1	Connector	or	orange
X10	4-pin connector of heater control	GM	Fan motor	ws	white
F3	1A fuse	M16	2-pin connector of GM	br	brown
F4	25A fuse	KB	A/C control unit		
F5	7.5A fuse	M05-B	32-pin connector of KB		
K1	Fan relay	GRr	Fan controller		
		M24	4-pin connector of GRr		
					Insulate wire end and tie back
				X	Cutting point
					Wiring colours may vary.

Legend

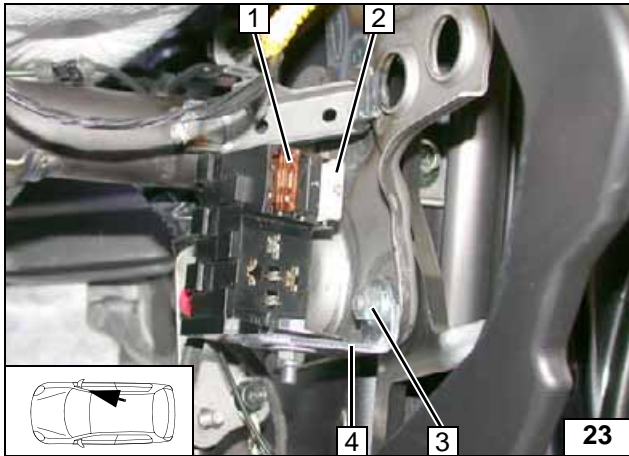

- 1 7.5A fuse F5
- 2 25A fuse F4
- 3 M6X20 bolt, flanged nut
- 4 Angle bracket

Installing passenger compartment relay and fuse holder

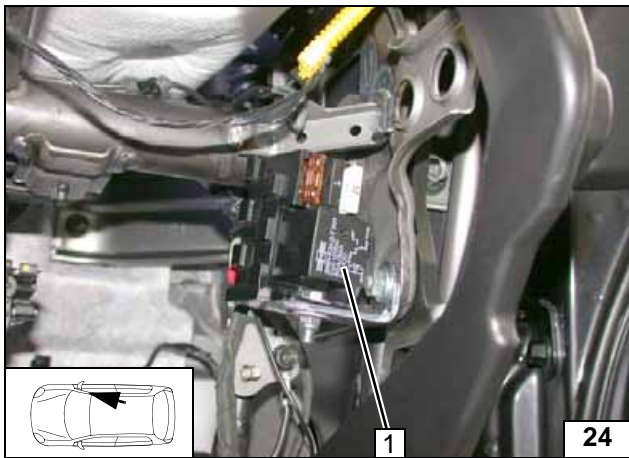

- 1 K1 relay

Attaching relay

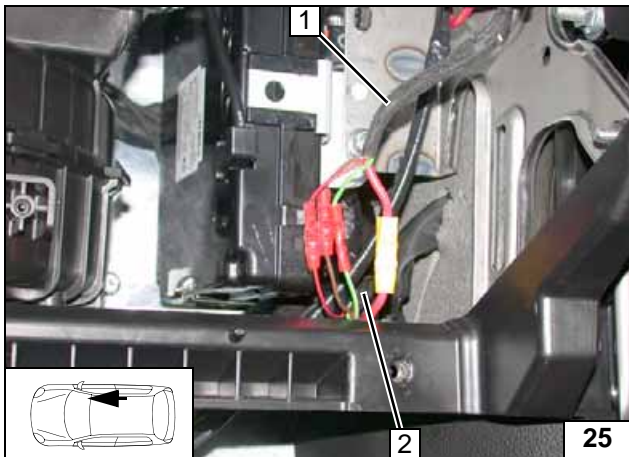

- 1 Wiring harness of passenger compartment relay and fuse holder
- 2 Wiring harness of heater



Connecting same colour wires of wiring harnesses

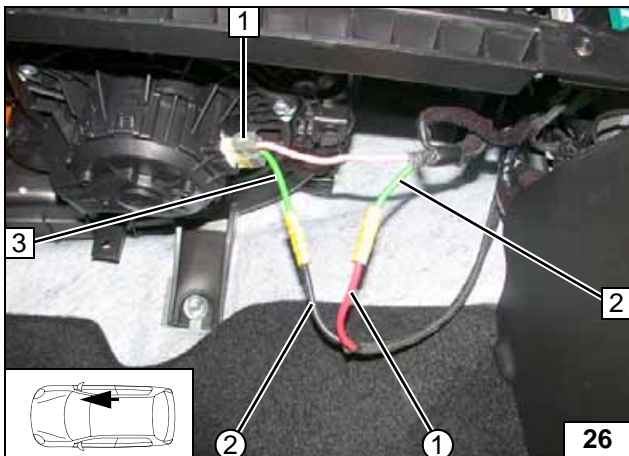

- 1 2-pin connector M16 of fan motor
- 2 Green (gn) wire from fan relay
- 3 Green (gn) wire of connector M16, pin 1
- ① Red (rt) wire of K1/87a, fan wiring harness
- ② Black (sw) wire of K1/30, fan wiring harness

Connecting fan motor

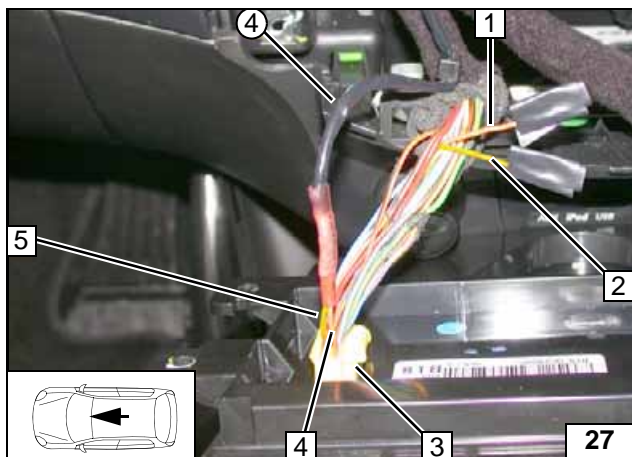

Insulate and tie back orange (or) wire **1** of fuse F14 and yellow (ge) wire **2** of fuse F25.



- 3** 32-pin connector M05-B of A/C control unit
- 4** Orange (or) wire of connector M05-B, pin 8
- 5** Yellow (ge) wire of connector M05-B, pin 14
- ④ Black (sw) wire of 7.5A fuse F5

**Connect-
ing A/C
control unit**



Digital Timer

A wiring harness extension is necessary for the installation of the digital timer.

- 1 Digital timer



Installing digital timer

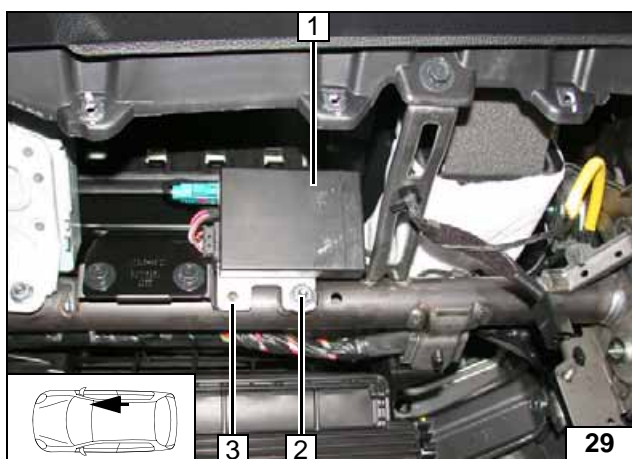

Remote Option (Telestart)

- 1 Receiver
- 2 Original vehicle stud bolt, M6 flanged nut
- 3 Bracket



Installing receiver

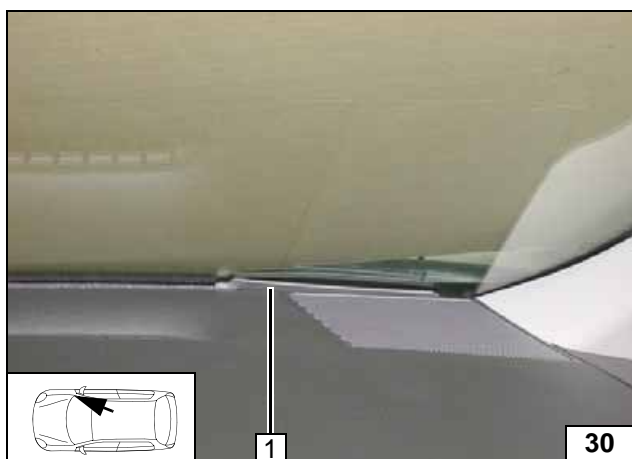

- 1 Aerial

Installing aerial

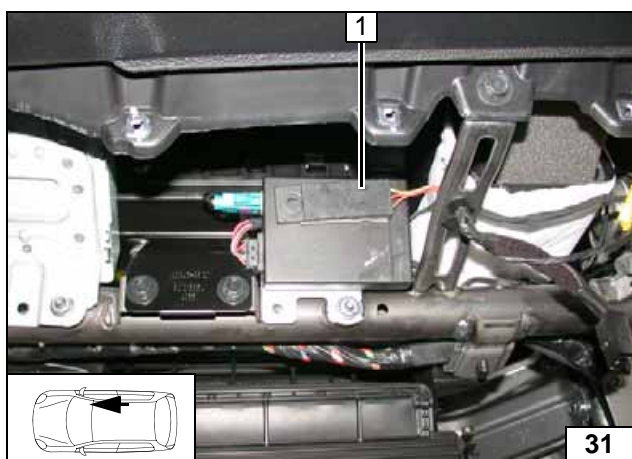

Temperature sensor T100 HTM

Fasten temperature sensor 1 with adhesive tape.



Installing temperature sensor

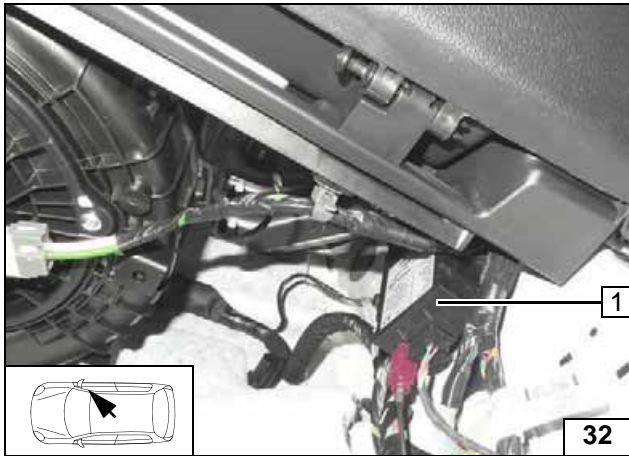

Thermo Call Option

Fasten receiver 1 with double-sided adhesive tape.

Installing receiver

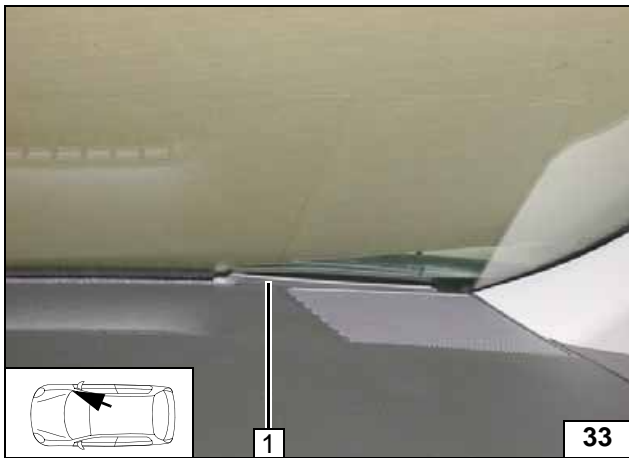

1 Aerial

Installing aerial

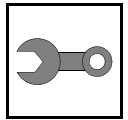

Preparing Installation Location



Cut out insulation mat in the area of marking 1.

Cutting out insulation mat

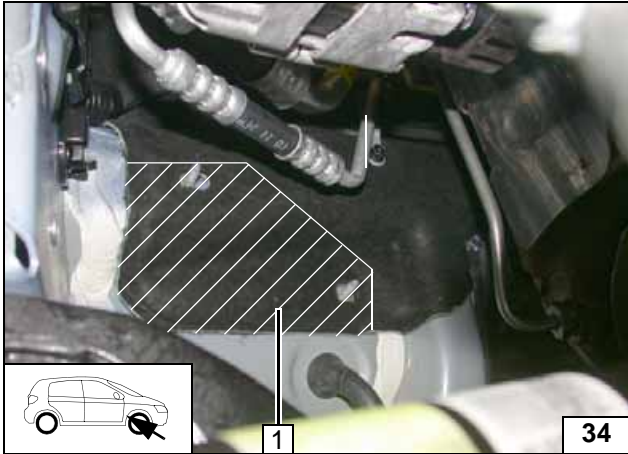

1 M6x40 spacer nut, original vehicle stud bolt

Installing spacer nut

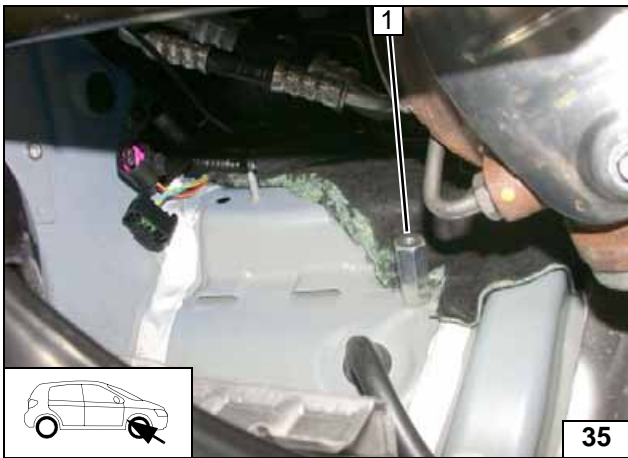

1 Drill out hole to 9.1 mm dia.; rivet nut [2x each]

Installing rivet nut

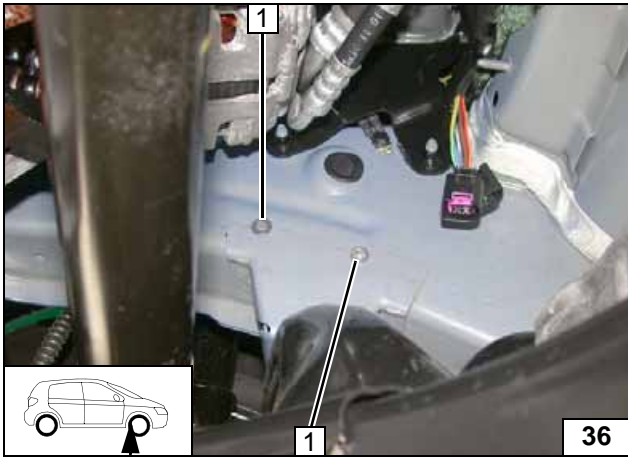

Insert 5mm shim between bracket section 1 and spacer nut. Align bracket section 1 upwards.



1 Flanged nut, original vehicle stud bolt
2 Bracket section 1
3 M6x20 bolt, spring lockwasher, 5mm shim

Installing bracket section 1

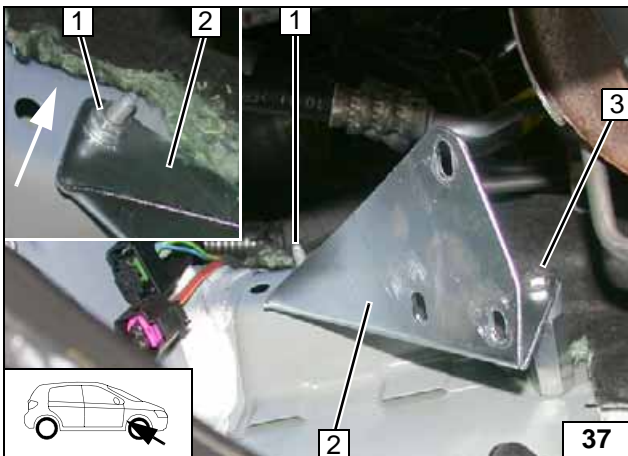

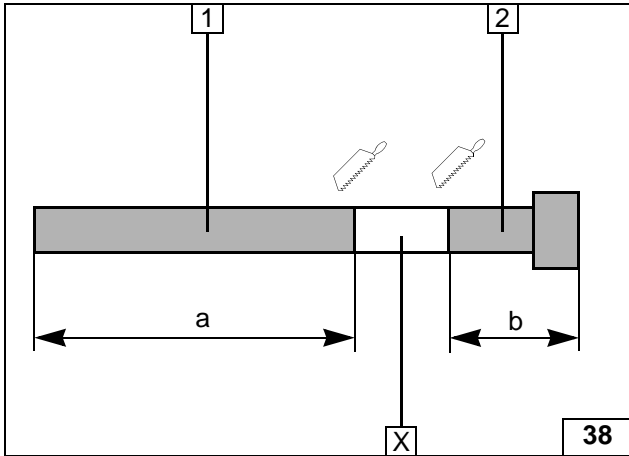
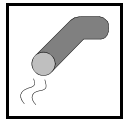

Exhaust Gas

Discard section X.

- 1 Exhaust pipe
a = 400
- 2 Exhaust end section
b = 140

Preparing exhaust pipe

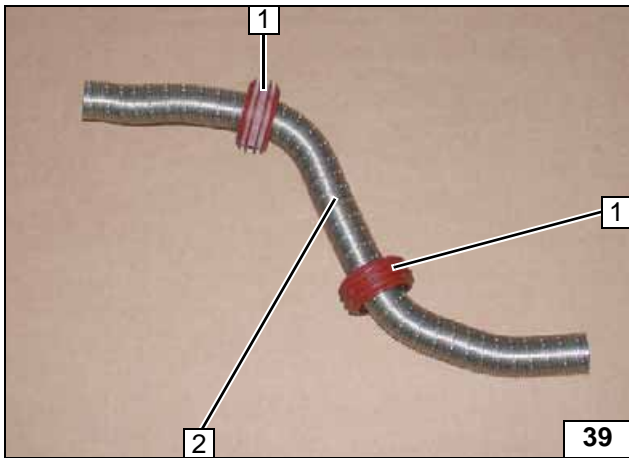

- 1 Slide on spacer bracket [2x]
- 2 Exhaust pipe

Preparing exhaust pipe

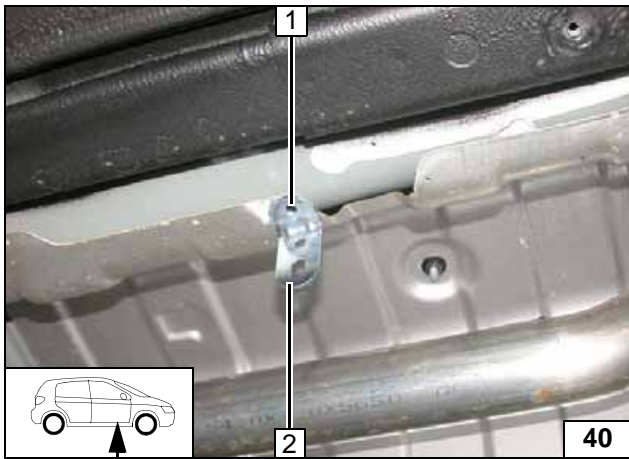

Place angle bracket 2 on the heat shield plate as shown.

- 1 Copy hole pattern, 7mm dia. hole

Hole for exhaust end section

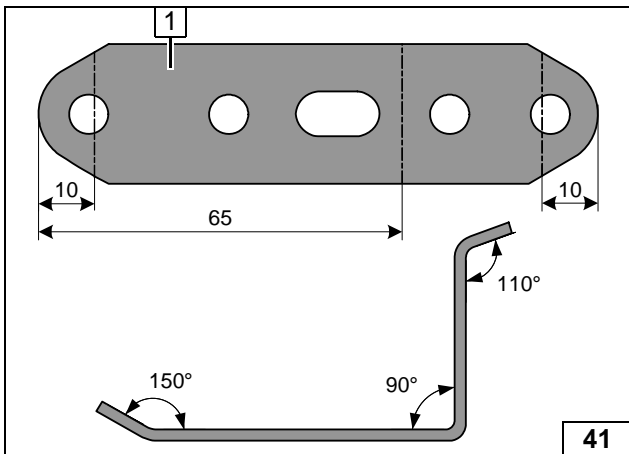

- 1 Perforated bracket

Angling down perforated bracket

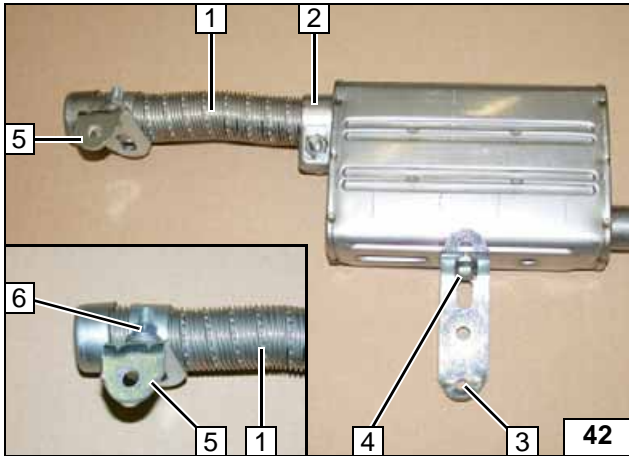
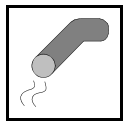

- 1 Exhaust end section
- 2 Hose clamp
- 3 Perforated bracket
- 4 M6x16 bolt, spring lockwasher
- 5 Angle bracket
- 6 M6x20 bolt, pipe clamp, flanged nut

**Premount-
silencer**

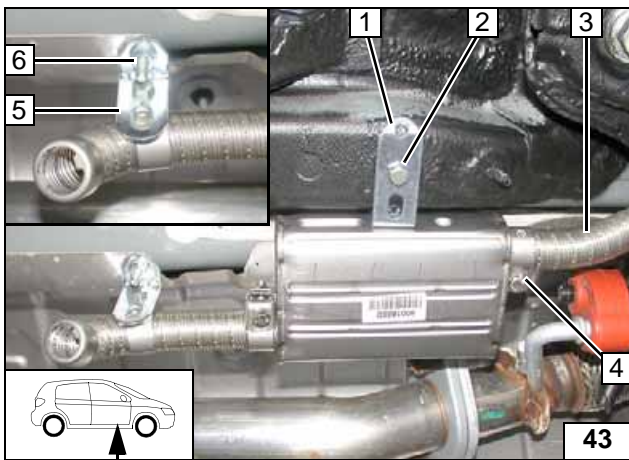

Ensure sufficient distance from neighbouring components, correct if necessary.



- 1 Perforated bracket
- 2 M6x20 bolt, spring lockwasher, large diameter washer, existing threaded hole (possibly hidden by underbody protection)
- 3 Exhaust pipe
- 4 Hose clamp
- 5 Angle bracket
- 6 M6x20 bolt, large diameter washer, flanged nut

**Installing
silencer
and ex-
haust end
section**

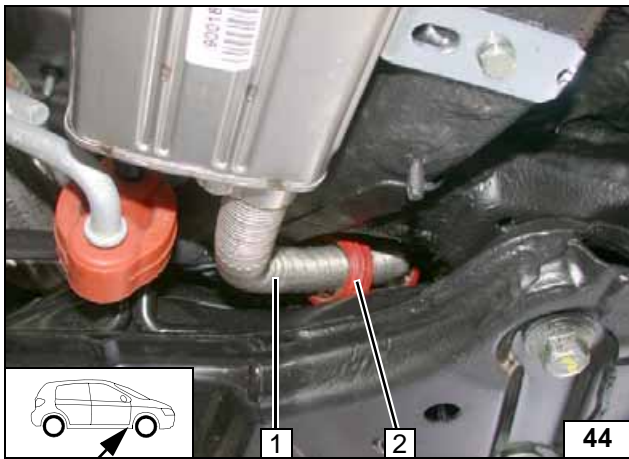

Align spacer bracket2 with exhaust pipe1.



**Installing
exhaust
pipe**

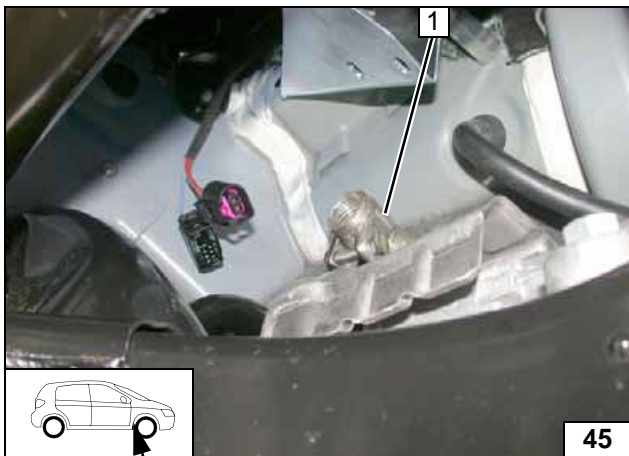

- 1 Slide on hose clamp

**Installing
exhaust
pipe**

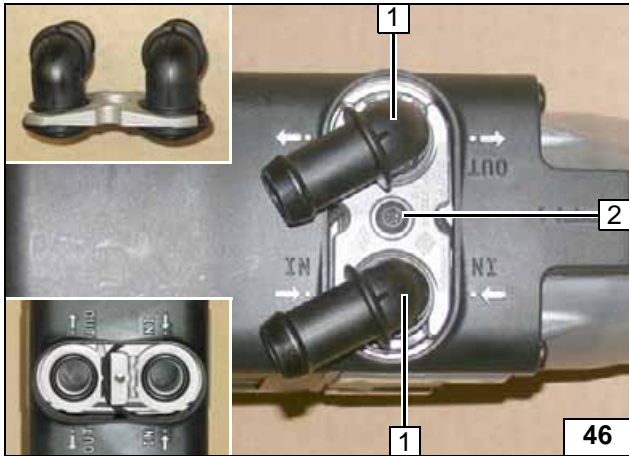
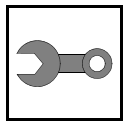

Preparing Heater

- 1 Water connection piece, sealing ring [2x each]
- 2 5x15 self-tapping bolt, retaining plate of water connection piece



Installing water connection piece

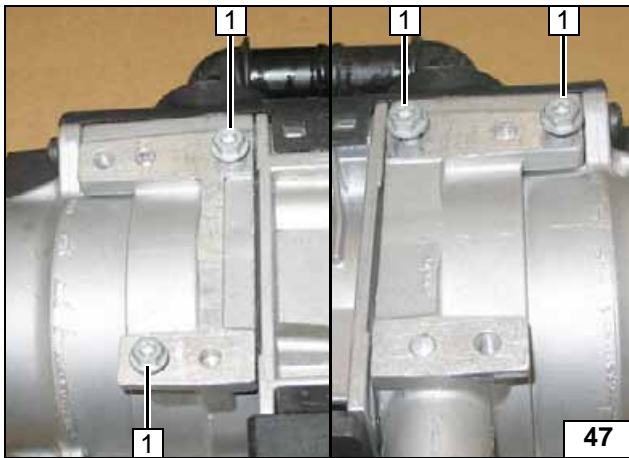

Screw 5x13 self-tapping bolts 1 [4x] into existing holes by a max. of 3 thread turns.



Premounting bolts loosely

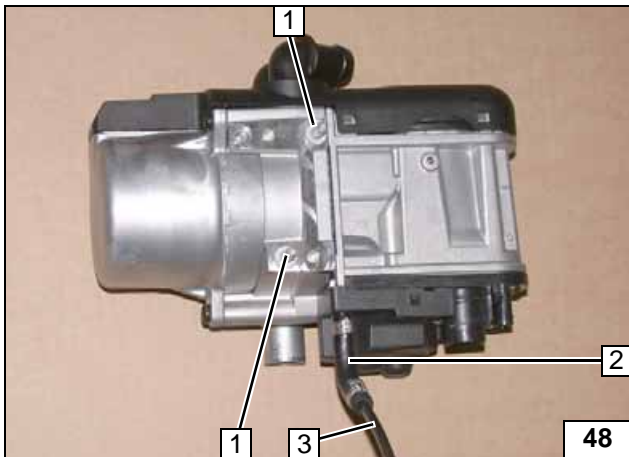

- 1 Stud bolt [2x]
- 2 90° moulded hose, 10mm dia. clamp [2x]
- 3 Fuel line

Premounting fuel line

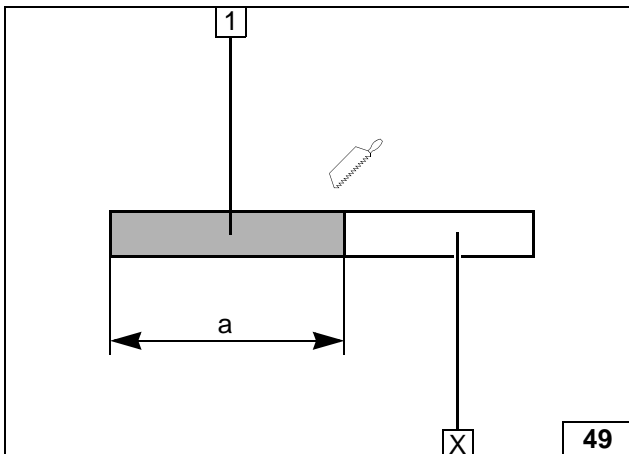

Discard section X.

- 1 Combustion air pipe
a = 670mm



Cutting combustion air pipe to length

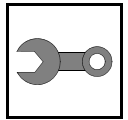

- 1 Combustion air pipe
- 2 Mount wiring harness of circulating pump

Premounting combustion air pipe

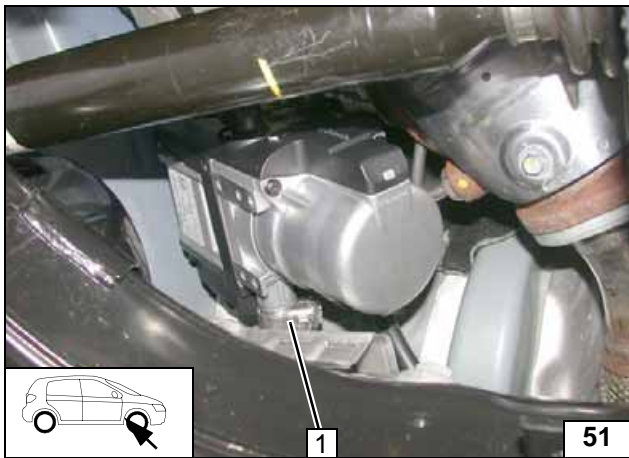

Installing Heater

Position heater at installation location. Mounting wiring harness on heater [2x].

- 1 Hose clamp

Installing exhaust pipe



Insert heater into oblong holes of bracket section 1 using stud bolts [2x] and loosely install it from behind using M6 flanged nut [2x] (see following image).

Mounting heater

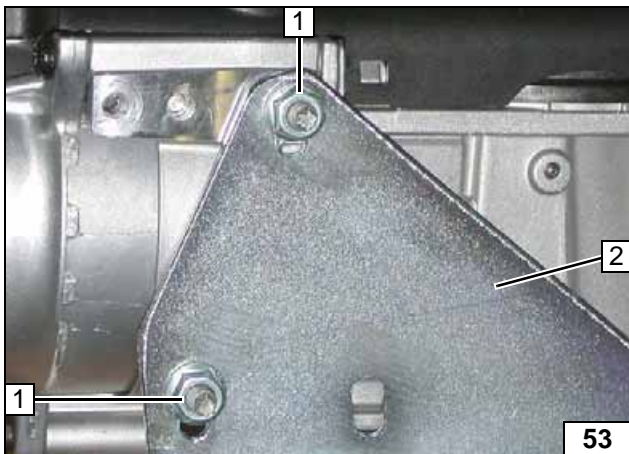
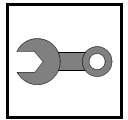

Image shows installation of heater on bracket section 1 - hidden side.

- 1 M6 flanged nut [2x]
- 2 Bracket section 1

Mounting heater



Routing combustion air pipe

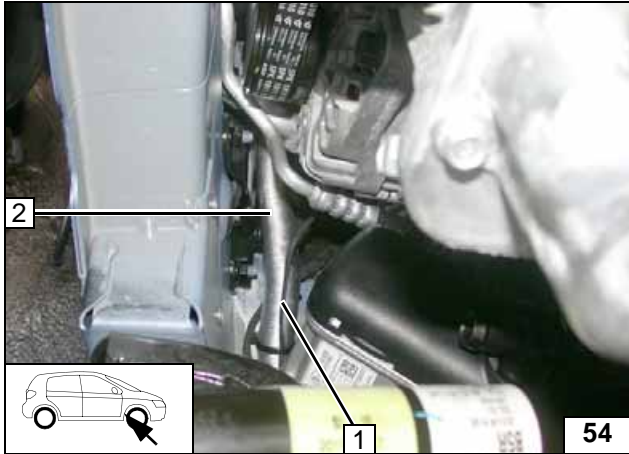

Route combustion air pipe 2 and wiring harness of circulating pump 1 upwards on the firewall.

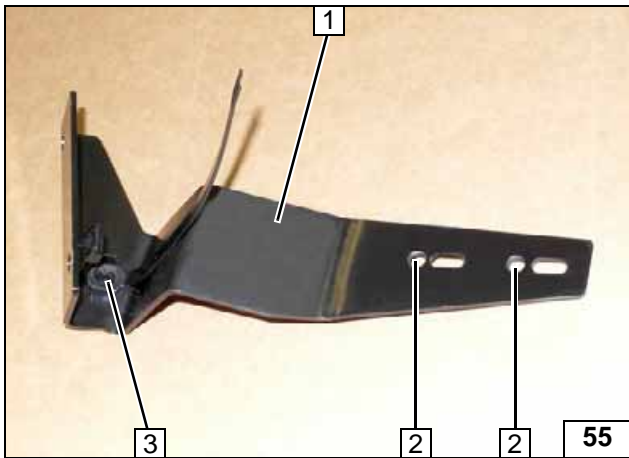

- 1 Bracket section 2
- 2 6mm dia. hole [2x] for fastening of heater
- 3 Insert clip-type cable tie, existing hole

Preparing bracket section 2

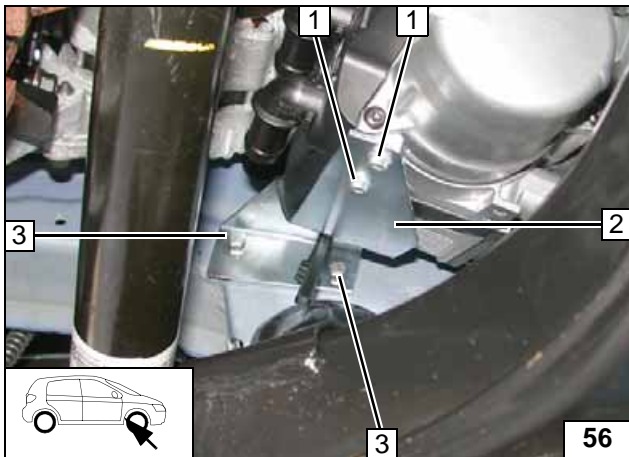

- 1 5x13 self-tapping bolt [2x]
- 2 Bracket section 2
- 3 M6x20 bolt, spring lockwasher [2x each]

Loosely installing heater



Align heater in such a way that there is a maximum distance between the heater and the stabiliser (coupling rod hung out and stabiliser in top position).



Aligning heater

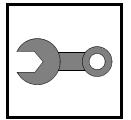

Align heater. Ensure max. distance to exhaust system at position **1**, correct if necessary. Tighten all loose screw connections.

**Mounting
heater**

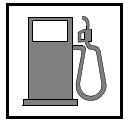

Fuel

CAUTION!

Open the vehicle's fuel tank cap, ventilate the tank and then re-close the tank lock.

Catch any fuel running off in a suitable container.

Route fuel line and metering pump wiring harness so that they are protected against stone impact. Unless specified otherwise, always fasten using cable ties. Provide rub protection for fuel line and wiring harness in areas where there are sharp edges.

WARNING!

The fuel line and wiring harness are routed to the metering pump as shown in the wiring harness routing diagram.



Routing lines

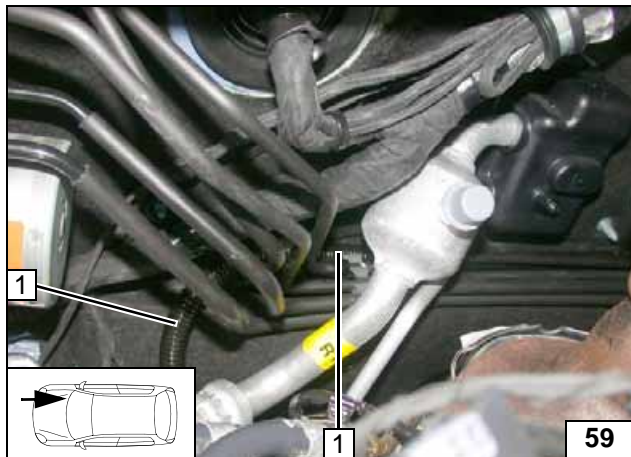

Route wiring harness of metering pump and fuel line in 10mm dia., 2100mm long corrugated tube 1 to the left side of the vehicle along original vehicle lines.

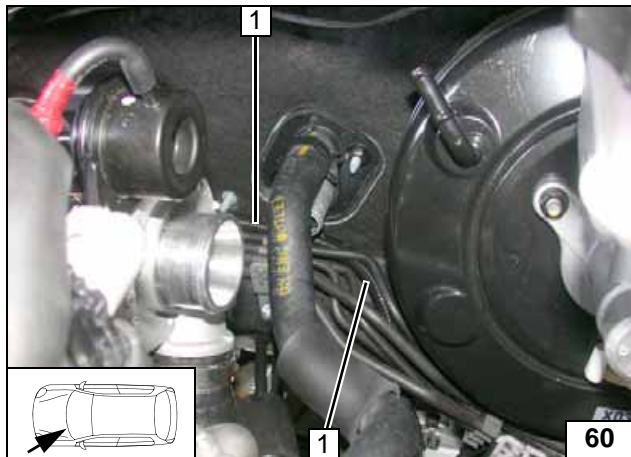

Route wiring harness of metering pump and fuel line in 10mm dia. corrugated tube 1 to the underbody along original vehicle lines.



Routing lines

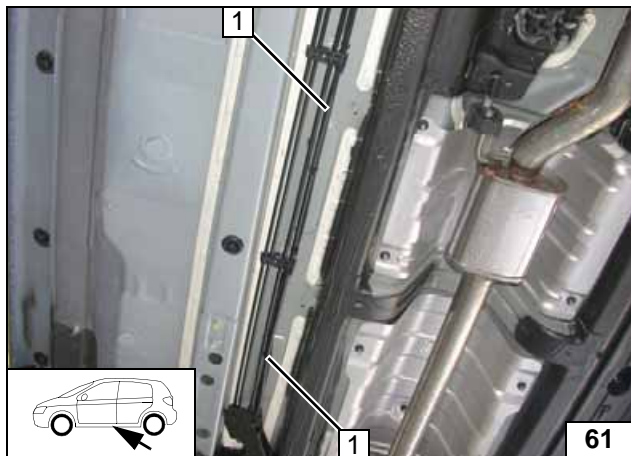

Route wiring harness of metering pump and fuel line in 10mm dia. corrugated tube 1 to the installation location of the metering pump along original vehicle lines.



Routing lines

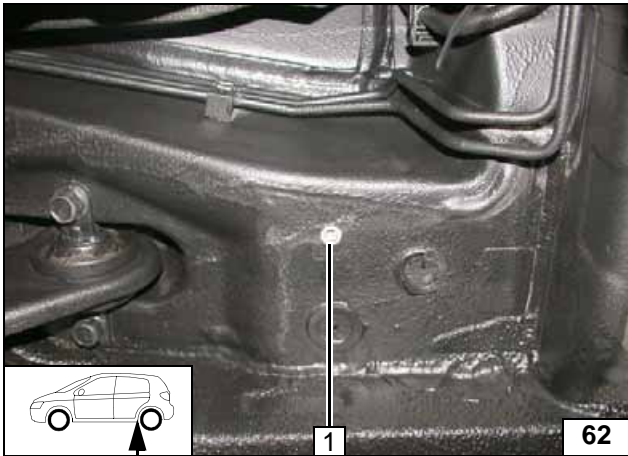
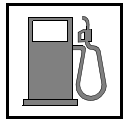

1 Rivet nut, existing hole

Installing rivet nut

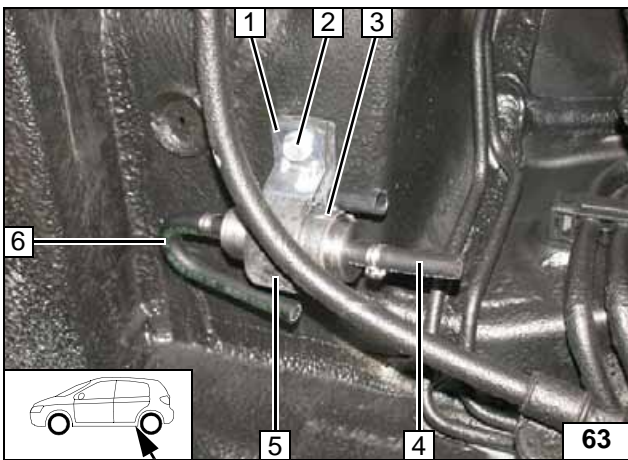

1 Support angle bracket
2 M6x25 bolt
3 Metering pump
4 Hose section, 10mm dia. clamp
5 Mounting of metering pump
6 180° moulded hose, 10mm dia. clamp



Mounting metering pump

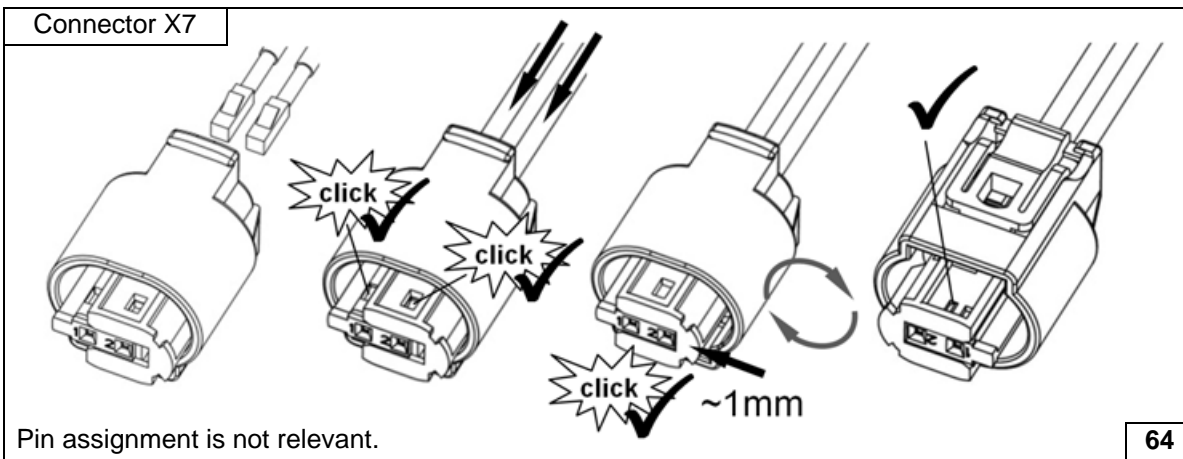

Completing metering pump connector

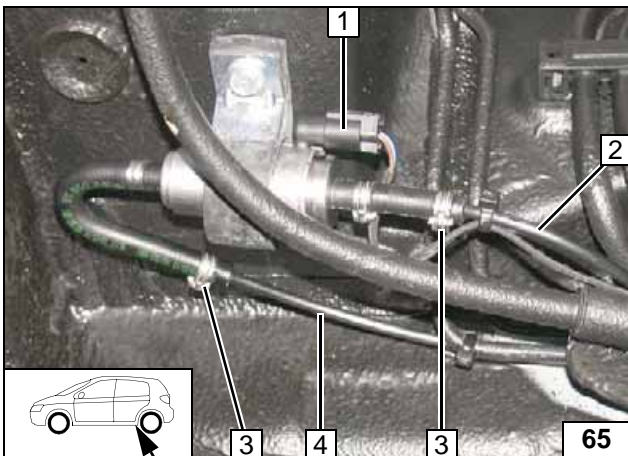

1 Wiring harness of metering pump, connector X7 mounted
2 Fuel line of heater
3 10mm dia. clamp [2x]
4 Fuel line of fuel standpipe

Connecting metering pump

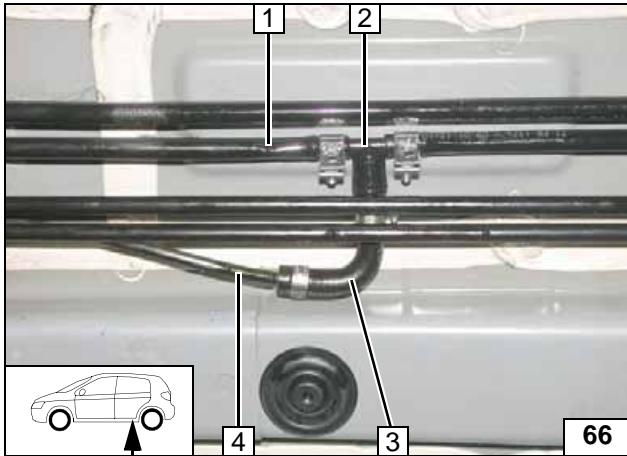
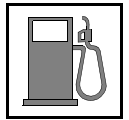

Separate fuel supply line **1** at position **2**.
Check the position of the components; adjust if necessary. Check that they have freedom of movement.

- 2** 6x5x6 fuel standpipe, 8mm dia. clamp [2x]
- 3** 90° moulded hose, 10mm dia. clamp [2x]
- 4** Fuel line

**Fuel ex-
traction**





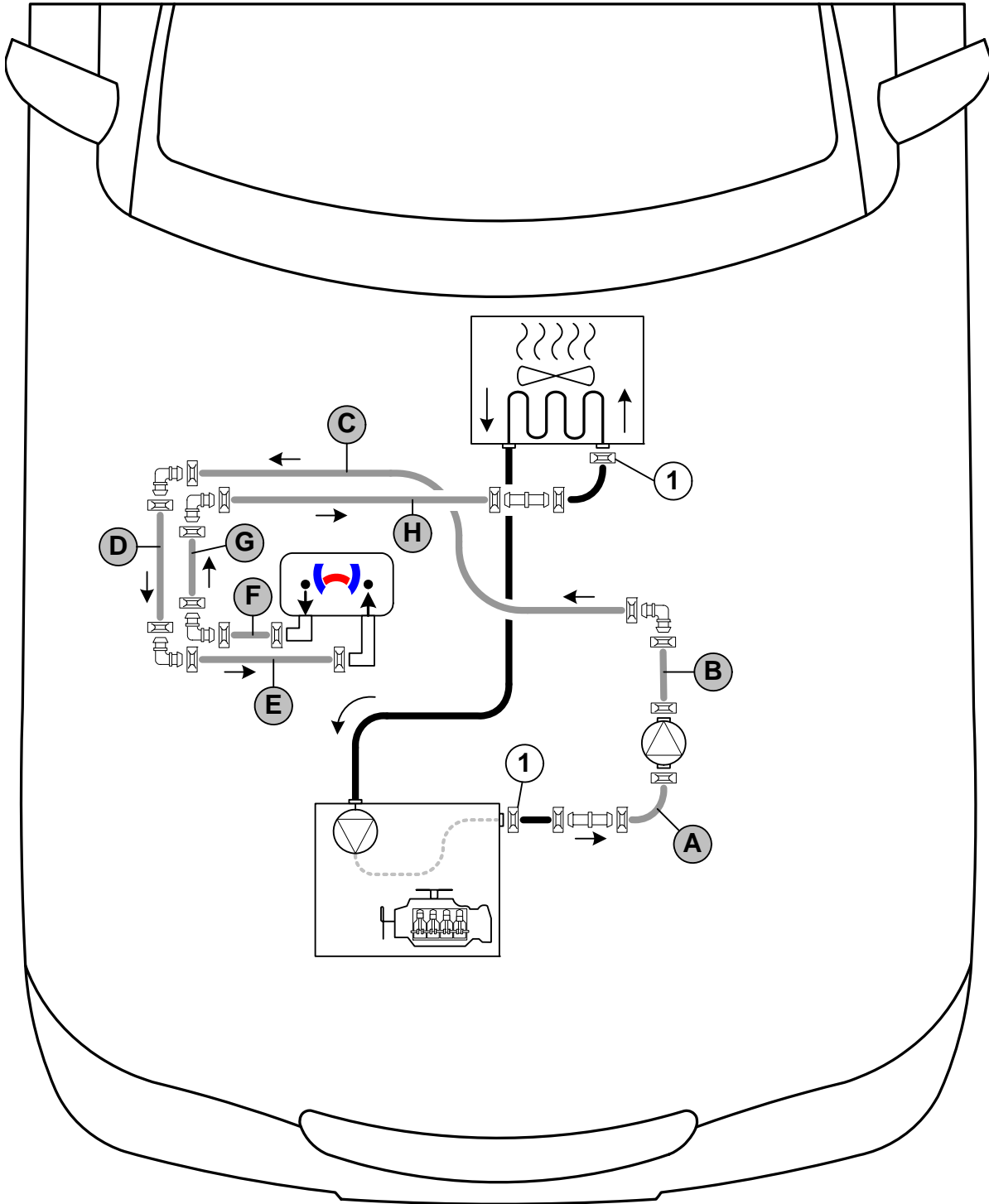

Coolant Circuit

WARNING!

Any coolant running off should be collected in a suitable container. Route hoses so that they are kink-free. Unless specified otherwise, always fasten using cable ties. Position clamps so that other hoses cannot be damaged. The heater must be filled with coolant when installing the hoses. The connection should be modelled on an "inline" circuit and based on the following diagram:



Hose routing diagram

All spring clips  = 25 mm dia.
 1 = Original vehicle spring clip .
 All connecting pipes  and  = 18x18mm dia.



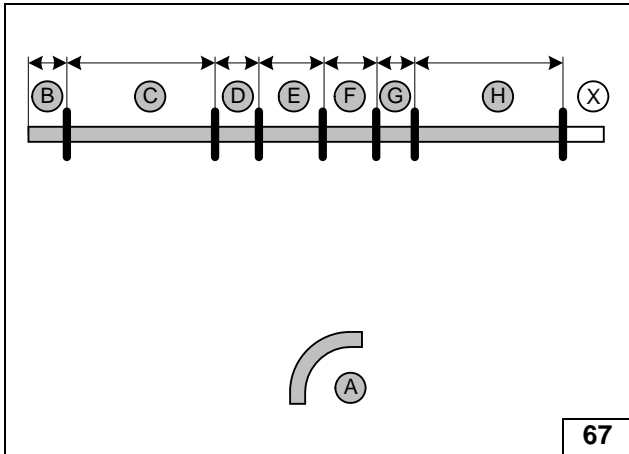

Discard section X.
Hose A = 90°, 18 mm dia. moulded hose

- B = 90
- C = 900
- D = 80
- E = 120
- F = 140
- G = 65
- H = 700



Cutting hoses to length

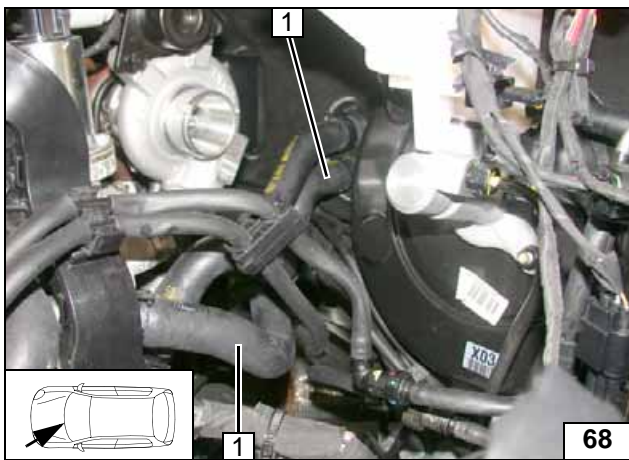

Remove hose on engine outlet / heat exchanger inlet 1. Spring clip will be reused!



Cutting point

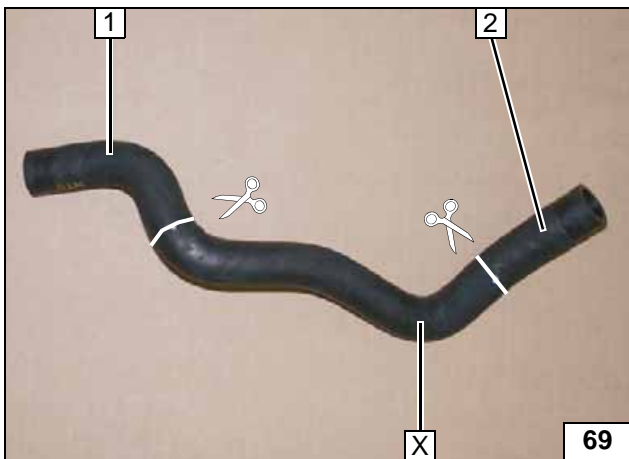

Discard section X.

- 1 Hose section of heat exchanger inlet
- 2 Engine outlet hose section

Cutting point

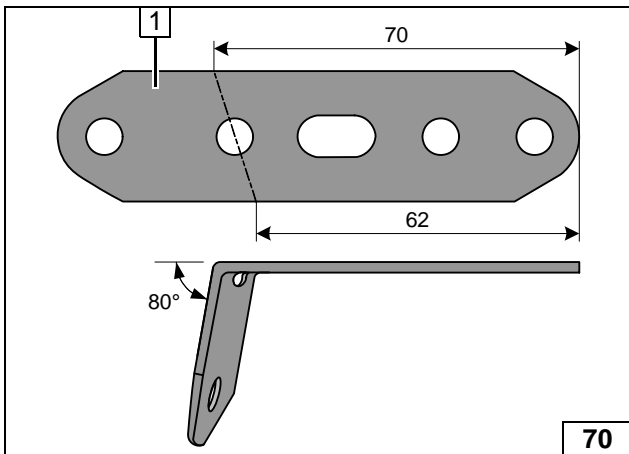

1 Perforated bracket



Angling down perforated bracket

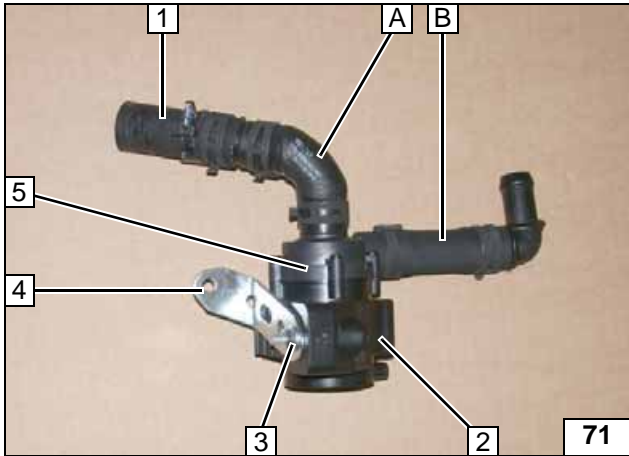

- 1 Hose of engine outlet
- 2 Circulating pump mounting
- 3 M6x25 bolt, flanged nut
- 4 Perforated bracket
- 5 Circulating pump

Premounting circulating pump

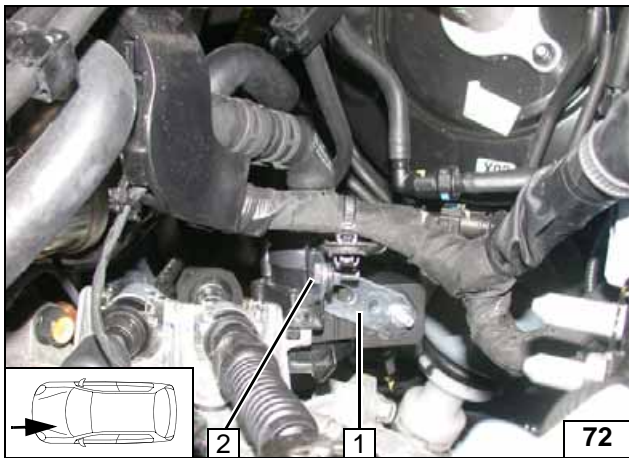

- 1 Perforated bracket
- 2 M6x20 bolt, flanged nut, existing hole

Installing circulating pump

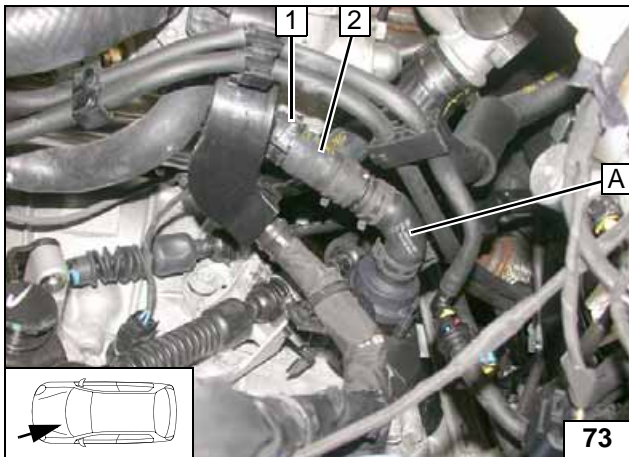

- 1 Original vehicle spring clip
- 2 Hose of engine outlet

Connecting engine outlet

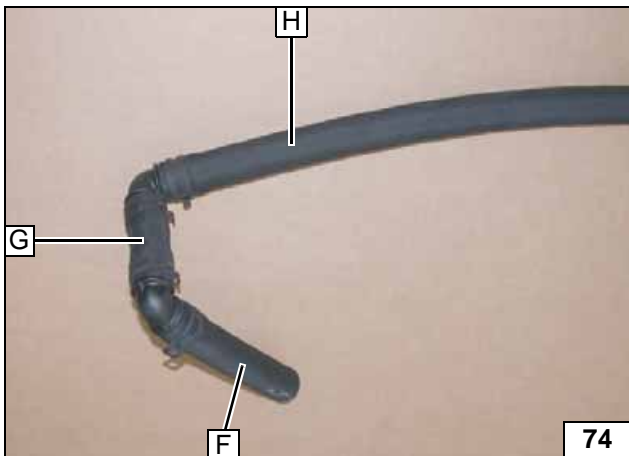

Premounting hoses



Route hose **H** upwards on the firewall.



Connect-
ing heater
outlet



Routing in
engine
compart-
ment

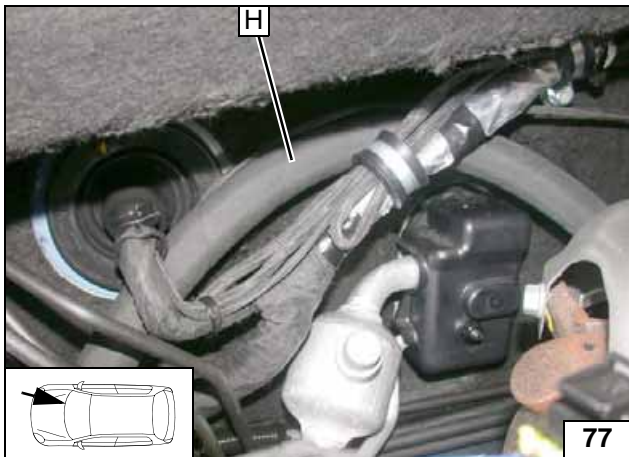

Route hose **H** to the left behind the original vehicle wiring harness.



Routing in
engine
compart-
ment

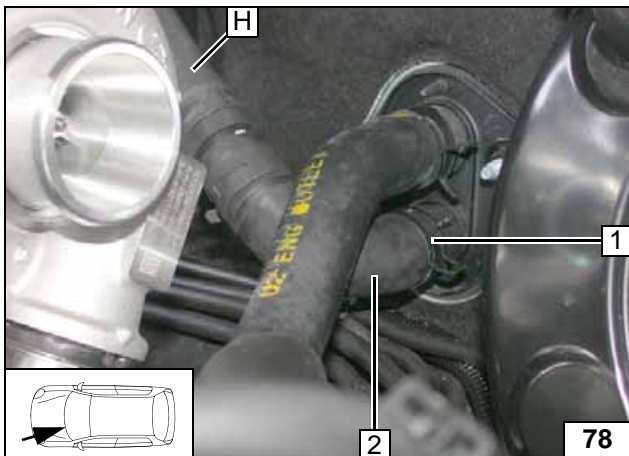

- 1 Original vehicle spring clip
- 2 Hose of heat exchanger inlet

Connect-
ing heat ex-
changer
inlet

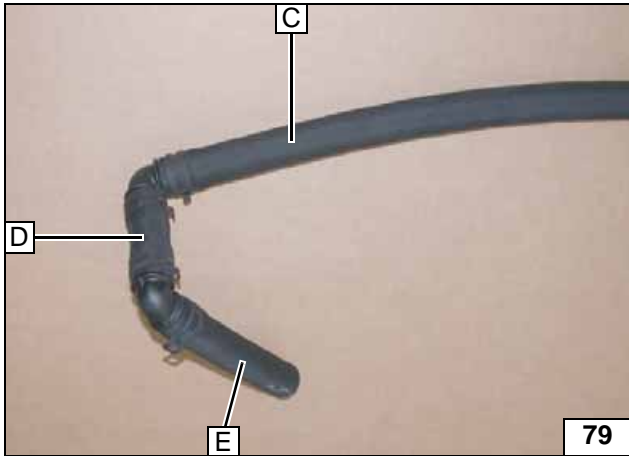

Premounting hoses



Route hose **C** upwards on the firewall along hose **H**.



Connecting heater inlet

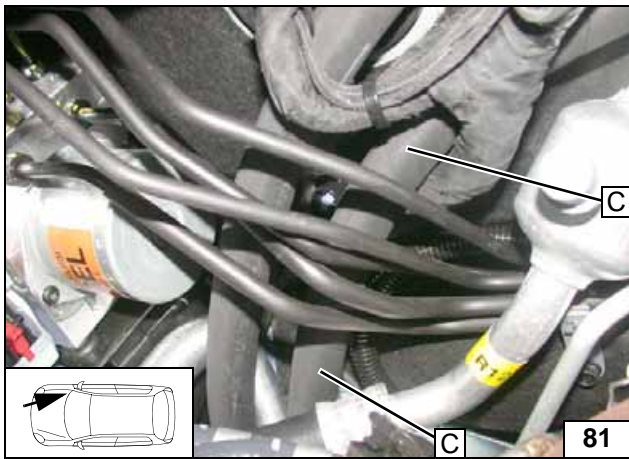

Routing in engine compartment

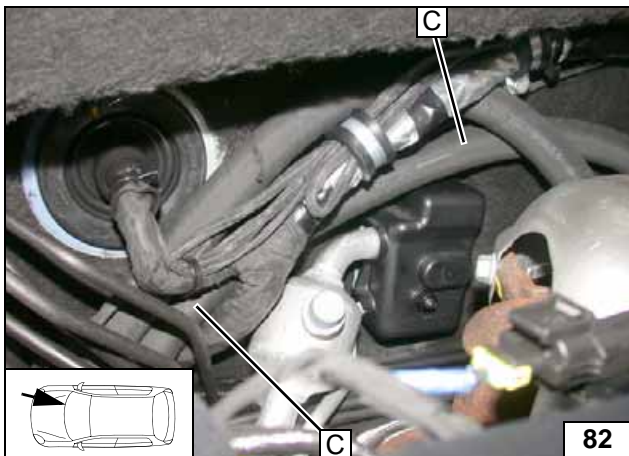

Route hose **C** to the left behind the original vehicle wiring harness.



Routing in engine compartment

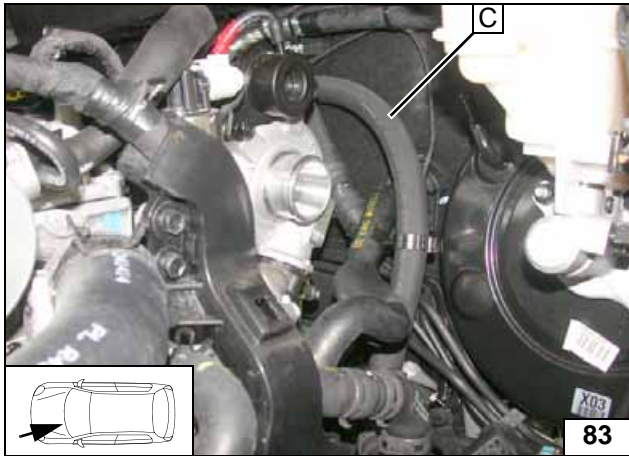

Route hose **C** to the circulating pump.



Routing in engine compartment

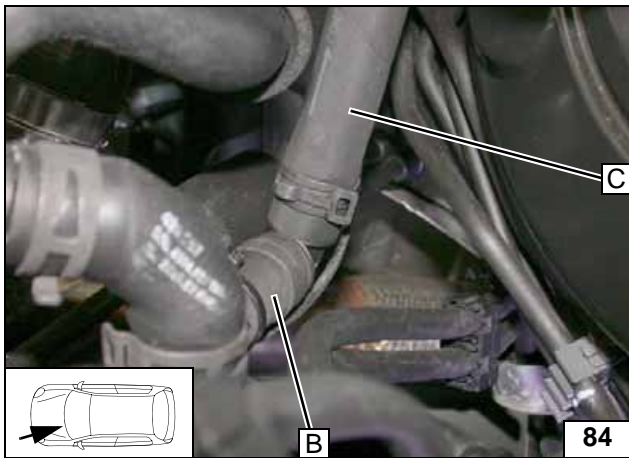

Connecting circulating pump

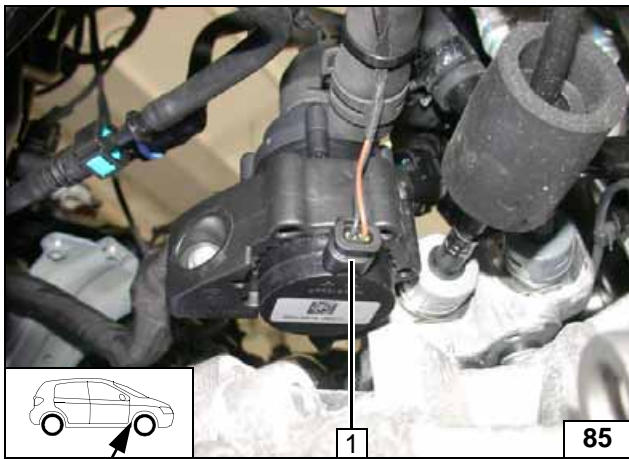

1 Wiring harness of circulating pump

Installing wiring harness

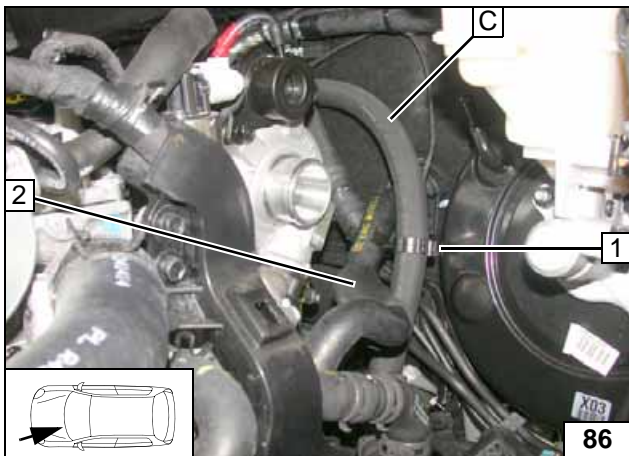

Align hoses. Ensure sufficient distance from neighbouring components, correct if necessary.



- 1 Hose bracket
- 2 Hose on heat exchanger outlet

Mounting hose bracket

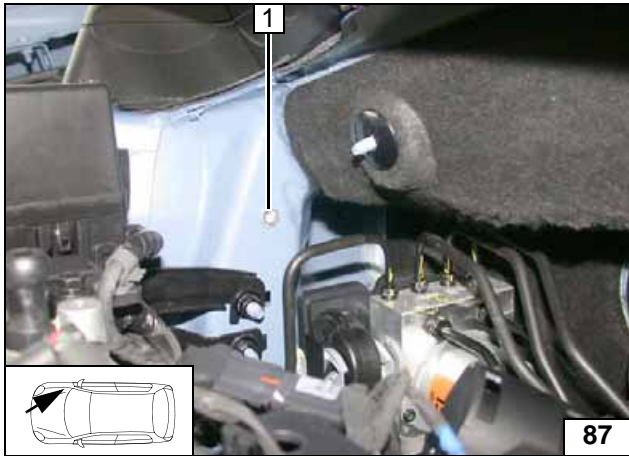
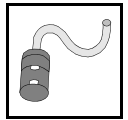

Combustion Air

- 1 Drill out existing hole to 9.1 mm dia.; rivet nut

Installing rivet nut

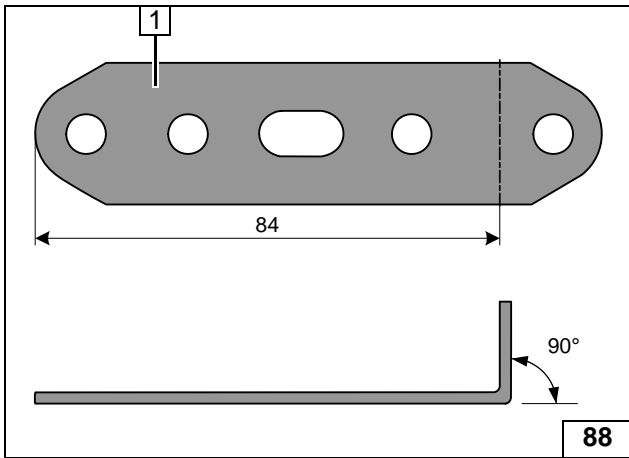

- 1 Perforated bracket



Angling down perforated bracket

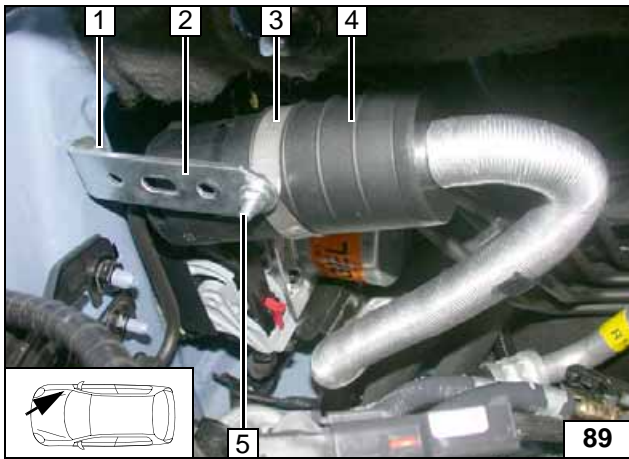

- 1 M6x20 bolt, spring lockwasher
- 2 Perforated bracket
- 3 51mm dia. clamp
- 4 Silencer
- 5 M6x20 bolt, flanged nut



Installing silencer

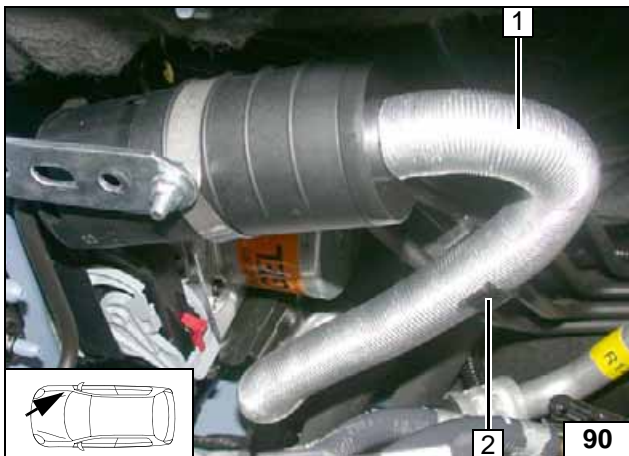

- 1 Combustion air pipe
- 2 8x22 spacer bracket on brake line

Installing combustion air pipe

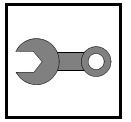

Final Work

WARNING!

Reassemble the components in reverse order. Check all hoses, clamps and all electrical connections for firm seating. Insulate and tie back all loose lines.

Only use manufacturer-approved coolant. Spray the heater components with anti-corrosion wax (Tectyl 100K, Order No. 111329).



- **Connect the battery.**
- **Fill and bleed the coolant circuit according to the vehicle manufacturer's specifications.**
- **Set the digital timer, teach Telestart transmitter**
- **Make settings on A/C control panel according to the "Operating Instructions for End Customer".**
- **Place the "Switch off parking heater before refuelling" caution label near the filler neck.**
- **For initial startup and function check, please see installation instructions.**

Operating Instructions for Manual Air-Conditioning

Please remove page and add to the vehicle operating instructions.

Note:

We recommend matching the heating time to the driving time.
Heating time = driving time

Example:

For a driving time of approx. 20 min. (in one direction), we recommend not exceeding a switch-on time of 20 min.

Passenger compartment monitoring, if installed, must be deactivated in addition to the vehicle settings for the heating operation.

For instructions on deactivation, please refer to the operating instructions of the vehicle.

Before parking the vehicle, make the following settings:



- 1 Air outlet to windscreen
- 2 Set fan to level "1", max. "2"
- 3 Set temperature to "max."

A/C control panel

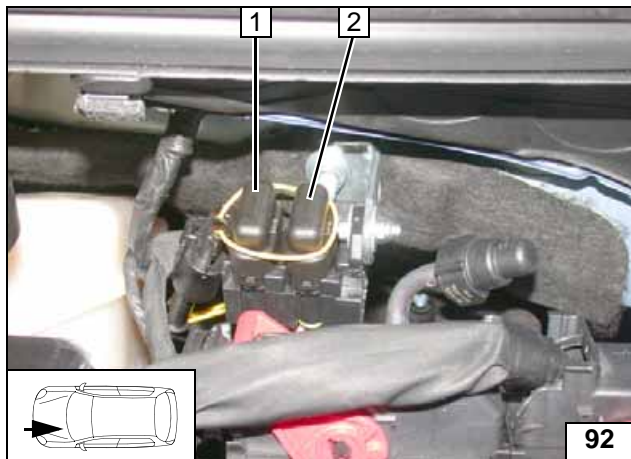

- 1 20A heater fuse F1
- 2 30A main fuse F2 of passenger compartment

Engine compartment fuses

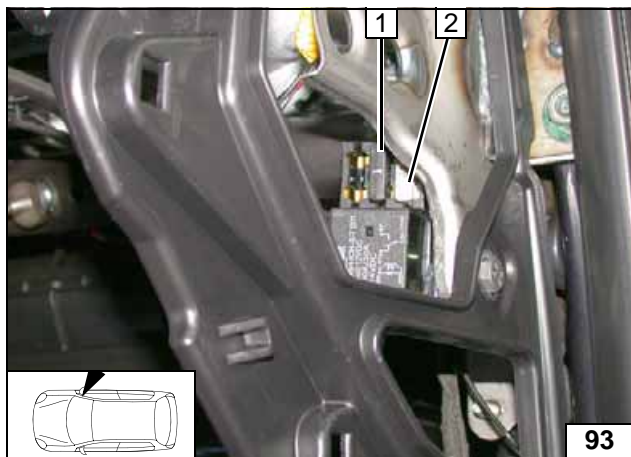

- 1 1A heater control fuse F3
- 2 25A fan fuse F4

Passenger compartment fuses



Operating Instructions for Automatic Air-Conditioning

Please remove page and add to the vehicle operating instructions.

Note:

We recommend matching the heating time to the driving time.
Heating time = driving time

Example:

For a driving time of approx. 20 min. (in one direction), we recommend not exceeding a switch-on time of 20 min.

Passenger compartment monitoring, if installed, must be deactivated in addition to the vehicle settings for the heating operation.

For instructions on deactivation, please refer to the operating instructions of the vehicle.

Before parking the vehicle, make the following settings:



- 1 Set temperature on both sides to "HI"
- 2 Air outlet faces "upward"
- 3 Set fan to level "2", max. "3"

A/C control panel

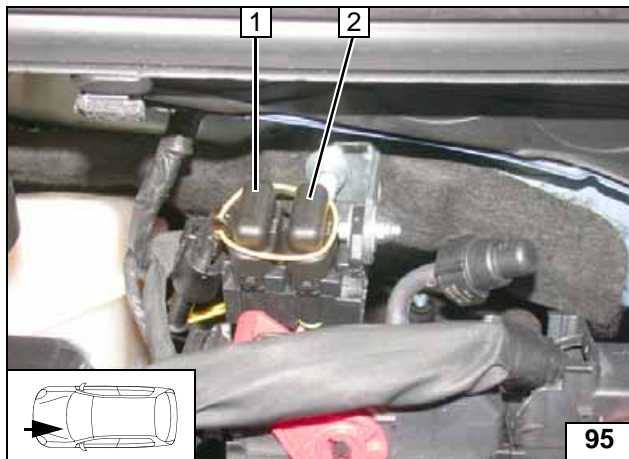

- 1 20A heater fuse F1
- 2 30A main fuse F2 of passenger compartment

Engine compartment fuses

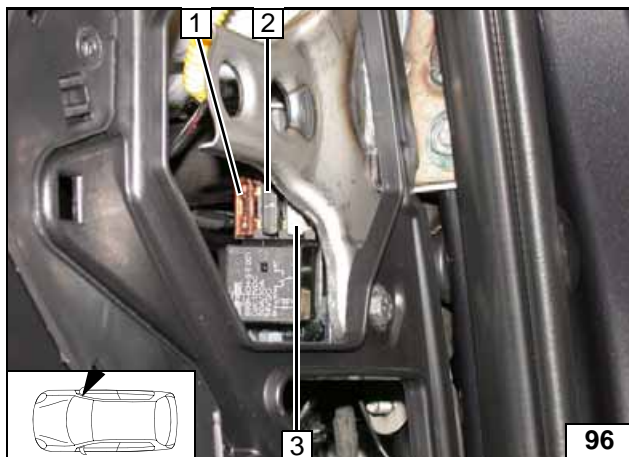

- 1 7.5A A/C control panel fuse F5
- 2 1A heater control fuse F3
- 3 25A fan fuse F4

Passenger compartment fuses

