

Water Heater

Thermo Top Evo Parking Heater



Installation Documentation

Mercedes Benz ML 250 (X166)

Validity

Manufacturer	Model	Type	EG-BE No. / ABE		
Mercedes Benz	ML 250 CDI	X166	e1 * 2007 / 46 * 0598 * ...		
Motorisation	Fuel	Transmission type	Output in kW	Displacement in cm ³	Engine code
250 CDI	Diesel R4	7G- Tronic	150	2143	OM 651

From Model Year 2012
Left-hand drive vehicle

Verified equipment variants:	Front fog light
	Headlight washer system
	ECO start-stop function
	Thermotronic
	Blue TEC
	Blue Efficiency
Not verified:	4 Matic
	Passenger compartment monitoring
Total installation time:	about 9.5 hours

Mercedes Benz ML 250 (X166)

Table of Contents

Validity	1	Preparing Installation Location	15
Necessary Components	2	Preparing Bracket	15
Installation Overview	2	Preparing Heater	16
Notes on Total Installation Time	2	Mounting Heater	17
Information on Operating and Installation Instructions	3	Exhaust Gas	18
Information on Validity	4	Fuel	19
Technical Information	4	Coolant Circuit	22
Explanatory Notes on Document	4	Final Work	29
Preliminary Work	5	Drilling Template of Bracket	30
Heater Installation Location	5	Operating Instructions for End Customer	31
Preparing Electrical System	6		
Electrical System	8		
Fan Controller	11		
Digital Timer	13		
Remote Option (Telestart)	13		
Remote Option (Thermo Call)	14		

Necessary Components

- Basic delivery scope of *Thermo Top Evobased* on price list
- Installation kit for Mercedes Benz ML 250 (X166) 2012: **1318716C**
- Heater control in accordance with price list and upon consultation with end customer
- In case of Telestart, indicator lamp in accordance with price list and in consultation with end customer

Installation instructions:

- The proper operation of the parking heater can only be guaranteed if the fuel tank is filled to at least a quarter. Please inform the end customer. Information available under section: "Operating Instructions for End Customer".
- The installation location of the push button in the case of Telestart or Thermo Call should be confirmed with the end customer.
- Depending on the available space and manufacturer's instructions, we recommend the use of a vehicle battery with more electrical capacity.

Installation Overview

Legend:

1. Heater
2. Fuse holder of engine compartment
3. Main fuse
4. CAN-node
5. CAN-node
6. Circulating pump
7. Digital timer
8. Metering pump

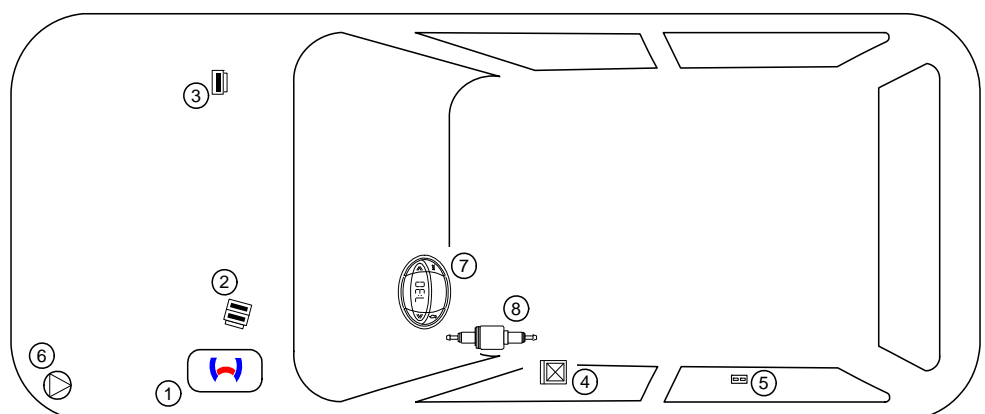

Notes on Total Installation Time

The total installation time includes the time needed for mounting and demounting of the vehicle-specific components, the heater specific installation time and all other times required for the system integration and initial start-up of the heater.

The total installation time may vary for vehicle equipment other than provided.

Information on Operating and Installation Instructions

1 Important Information (not complete)

1.1 Installation and Repair



The improper installation or repair of Webasto heating and cooling systems can cause fire or the leakage of deadly carbon monoxide, leading to serious injury or death.



To install and repair Webasto heating and cooling systems you need to have completed a special company training course and have the appropriate technical documentation, special tools and special equipment.



Installation and repair may ONLY be carried out by persons trained and certified in a Webasto training course. NEVER try to install or repair Webasto heating or cooling systems if you have not completed a Webasto training course, you do not have the necessary technical skills and you do not have the technical documentation, tools and equipment available to ensure that you can complete the installation and repair work properly.

Only use genuine Webasto parts. See the Webasto air and water heaters accessories catalogue for this purpose.

1.2 Operation

To ensure safe operation, we recommend having the heater checked every two years by an authorised Webasto dealer, especially when used over a long period and/or under extreme environmental conditions.

Do not operate the heater in closed rooms due to the danger of poisoning and suffocation.

Always switch off the heater before refuelling.

The heater may only be used with the prescribed fuel Diesel (DIN EN 590) or petrol (DIN EN 227).

The heater may not be cleaned with a high-pressure cleaner.

1.3 Please note

ALWAYS follow all Webasto installation and operating instructions and observe all warnings.

To become familiar with and understand all functions and properties of the heater, the operating instructions must be read carefully and observed at all times.

For proper, safe installation and repair work, the installation instructions with all warnings and safety information must be carefully read and observed at all times. Please always contact a workshop authorised by Webasto for all installation and repair work.

Important

Webasto shall assume no liability for defects, damage and injuries resulting from a failure to observe the installation, repair and operating instructions of the information contained in them.

This liability exclusion particularly applies to improper installations and repairs, installations and repairs by untrained persons or in the case of a failure to use genuine spare parts.

The liability due to culpable disregard to life, limb or health and due to damage or injuries caused by a wilful or reckless breach of duty remain unaffected, as does the obligatory product liability.

Installation should be carried out according to the general, standard rules of technology. Unless specified otherwise, fasten hoses, lines and wiring harnesses to original vehicle lines and wiring harnesses using cable ties. Insulate loose wire ends and tie back. Connectors on electronic components must audibly snap into place during assembly.

Sharp edges should be fitted with rub protection. Spray unfinished body areas, e.g. drilled holes, with anti-corrosion wax (Tectyl 100K, Order No. 111329).

Observe the instructions and guidelines of the respective vehicle manufacturer for demounting and mounting vehicle specific components!

The initial startup is to be executed with the Webasto Thermo Test Diagnosis.

When installing an IPCU, the corresponding settings must be checked or adjusted.

2 Statutory regulations governing installation

Guidelines	Thermo Top Evo
Heating Directive ECE R122	E1 00 0258
EMC Directive ECE R10	E1 04 5627

Note

The regulations of these guidelines are binding in the scope of the Directive 70/156/EEC and/or 2007/46/EC (for new vehicle models from 29/04/2009) and should also be observed in countries in which there are no special regulations.

Important

Failure to follow the installation instructions will result in the invalidation of the type approval for the heater and therefore invalidation of the general **homologation of the vehicle**.

Note

For vehicles with an EU permit, no entry in accordance with § 19 Sub-Section 4 of Annex VIII b to the Road Traffic Act is required.

2.1 Excerpt from the directive 2001/56/EC Appendix VII for the installation of the heater

Beginning of excerpt.

ANNEX VII

REQUIREMENTS FOR COMBUSTION HEATERS AND THEIR INSTALLATION

1. GENERAL REQUIREMENTS

1.7.1. A clearly visible tell-tale in the operator's field of view shall inform when the combustion heater is switched on or off.

2. VEHICLE INSTALLATION REQUIREMENTS

2.1. Scope

2.1.1. Subject to paragraph 2.1.2. combustion heaters shall be installed according to the requirements of this Annex.

2.1.2. Vehicles of category O having liquid fuel heaters are deemed to comply with the requirements of this Annex.

2.2. Positioning of heater

2.2.1. Body sections and any other components in the vicinity of the heater must be protected from excessive heat and the possibility of fuel or oil contamination.

2.2.2. The combustion heater shall not constitute a risk of fire, even in the case of overheating. This requirement shall be deemed to be fulfilled if the installation ensures an adequate distance to all parts and suitable ventilation, by the use of fire resistant materials or by the use of heat shields.

2.2.3. In the case of M2 and M3 vehicles, the heater must not be positioned in the passenger compartment. However, an installation in an effectively sealed envelope which also complies with the conditions in paragraph 2.2.2 may be used.

2.2.4. The label referred to in paragraph 1.4 or a duplicate, must be positioned so that it can be easily read when the heater is installed in the vehicle.

2.2.5. Every reasonable precaution should be taken in positioning the heater to minimise the risk of injury and damage to personal property.

2.3. Fuel supply

2.3.1. The fuel filler must not be situated in the passenger compartment and must be provided with an effective cap to prevent fuel spillage.

2.3.2. In the case of liquid fuel heaters, where a supply separate to that of the vehicle is provided, the type of fuel and its filler point must be clearly labelled.

2.3.3. A notice, indicating that the heater must be shut down before refuelling, must be affixed to the fuelling point. In addition a suitable instruction must be included in the manufacturer's operating manual.

2.4. Exhaust system

2.4.1. The exhaust outlet must be located so as to prevent emissions from entering the vehicle through ventilators, heated air inlets or opening windows.

2.5. Combustion air inlet

2.5.1. The air for the combustion chamber of the heater must not be drawn from the passenger compartment of the vehicle.

2.5.2. The air inlet must be so positioned or guarded that blocking by rubbish or luggage is unlikely.

2.6. Heating air inlet

2.6.1. The heating air supply may be fresh or recirculated air and must be drawn from a clean area not likely to be contaminated by exhaust fumes emitted either by the propulsion engine, the combustion heater or any other vehicle source.

2.6.2. The inlet duct must be protected by mesh or other suitable means.

2.7. Heating air outlet

2.7.1. Any ducting used to route the hot air through the vehicle must be so positioned or protected that no injury or damage could be caused if it were to be touched.

2.7.2. The air outlet must be so positioned or guarded that blocking by rubbish or luggage is unlikely.

End of excerpt.

In multilingual versions the German language is binding.

Mercedes Benz ML 250 (X166)

Information on Validity

This installation documentation applies to Mercedes Benz ML 250 (X166) Diesel vehicles - for validity, see page 1 - from model year 2012 and later, assuming technical modifications to the vehicle do not affect installation, any liability claims excluded. Depending on the vehicle version and equipment, modifications may be necessary during installation with respect to this installation documentation.

Vehicle and engine types, equipment variants and other specifications not listed in this installation documentation have not been tested. However, installation according to this installation documentation may be possible.

Technical Information

Special Tools

- Hose clamp pliers for self-clamping hose clamps
- Hose clamp pliers for Clic hose clamps of type W
- Automatic wire stripper 0.2 - 6mm²
- Crimping pliers for cable lug / tab connector 0.5 - 6mm²
- Torque wrench for 2.0 - 10 Nm
- Hose clamping pliers
- Metric thread-setter kit
- Webasto Thermo Test diagnosis with current software

Dimensions

- All dimensions are in mm.

Tightening torque values

- Tightening torque values of 5x13 heater bolts = 8Nm.
- Tightening torque values of 5x15 retaining plate of water connection piece bolt = 7Nm.
- Tighten other bolt connections in accordance with manufacturer's instructions or in accordance with state-of-the-art-technology.

Explanatory Notes on Document

You will find an identification mark on the outside top right corner of the page in question to provide you with a quick overview of the individual working steps.

Special features are highlighted using the following symbols:

Mechanical system



Electrical system



Coolant circuit

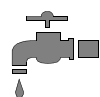

Combustion air

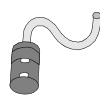

Fuel

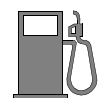

Exhaust gas



Software



Specific risk of injury or fatal accidents



Specific risk of damage to components



Specific risk of fire or explosion.



Reference to general installation instructions of the Webasto components or to the manufacturer's vehicle-specific documents.



Reference to a special technical feature



The arrow in the vehicle icon indicates the position on the vehicle and the viewing angle.

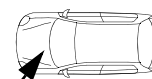
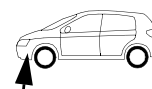

Mercedes Benz ML 250 (X166)

Preliminary Work

Vehicle

- Open the fuel tank cap, ventilate the tank.
- Close the fuel tank cap again.
- Disconnect the battery earth connection. (Move the front passenger's seat forward and remove the battery cover under the seating).
- Depressurise the cooling system.
- Pull off the front transversal sealing strip above the engine compartment partition wall, remove the trim on the left and right-hand sides.
- Remove the segment of the engine compartment partition wall over the water hoses.
- Detach the coolant expansion tank.
- Remove the design cover of the engine.
- Remove the cover of the fuse box on the right-hand side in the engine compartment.
- Remove the left-hand front wheel.
- Remove the two-piece wheel well trim of the left front wheel.
- Remove the lower engine trim.
- Remove the vehicle underbody trim.
- Remove the A-pillar trim in the driver's side footwell.
- Detach the lower footwell trim on the driver's side.
- Remove the footmat on the driver's side and remove the footwell trim.
- Remove the door sill cover on the driver's side in the front and in the rear.

Heater

- Remove years that do not apply from the type and duplicate label.
- Attach the duplicate label (type label) in the appropriate place inside the engine compartment.

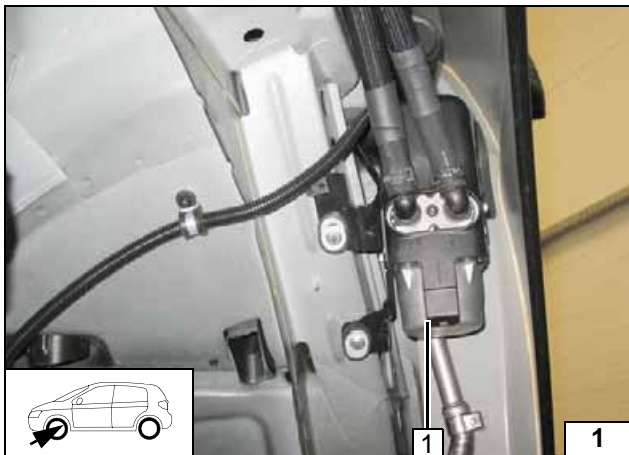

Heater Installation Location

1 Heater

Installation
location

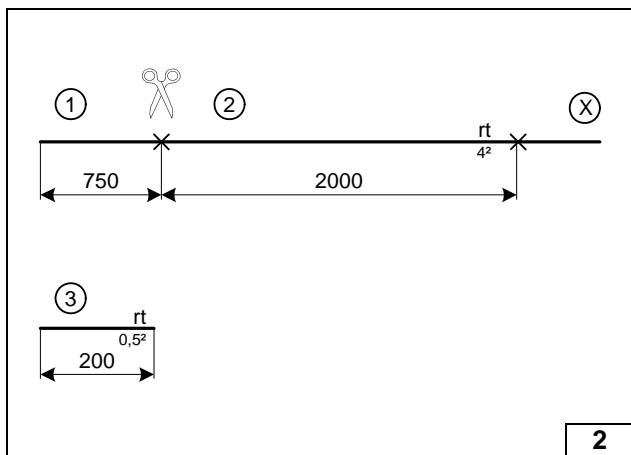

Preparing Electrical System

Wire sections retain their numbering in the entire document.
Discard section X.



Cutting wires to length

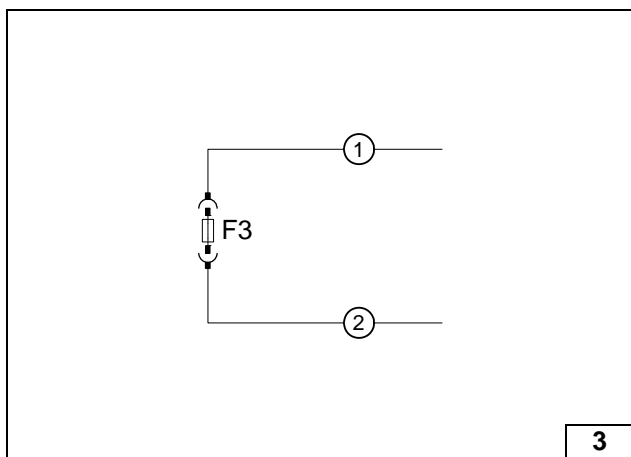

Insert red (rt) wire ② and red (rt) wire ① into sockets of fuse holder F3. 30A main fuse F3 will only be inserted during final work. Replace 30A fuse F2 with 1A fuse.



Connecting wires

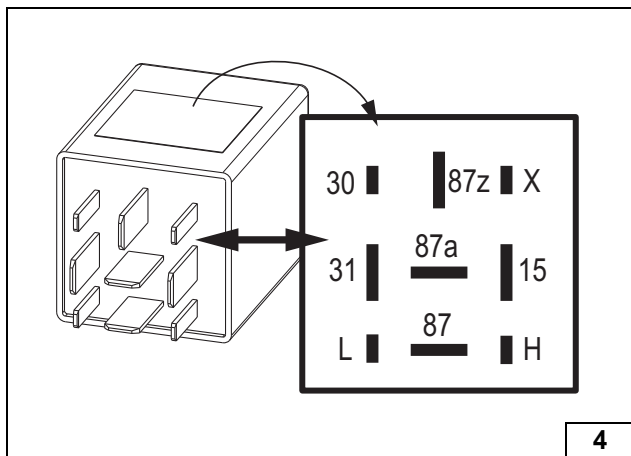

View of CAN module

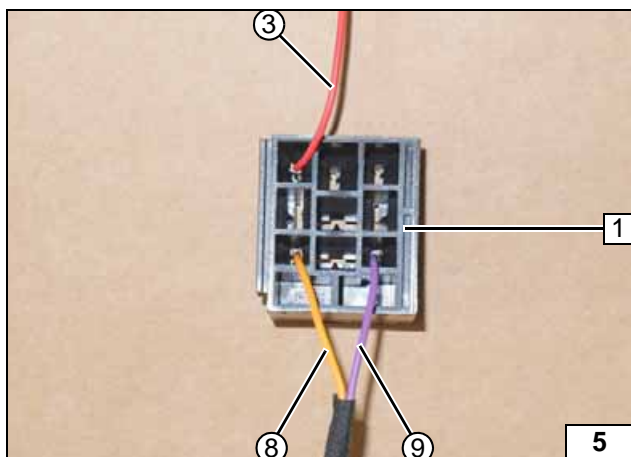

Connect wires according to the wiring diagram (see following image). CAN-Module is only inserted after installation.



- 1 Relay socket
- ③ Red (rt) wire of SPS CAN-Module/30
- ⑧ Orange (or) wire of SPS CAN-Module/L
- ⑨ Violet (vi) wire of SPS CAN-Module/H

Premounting wires

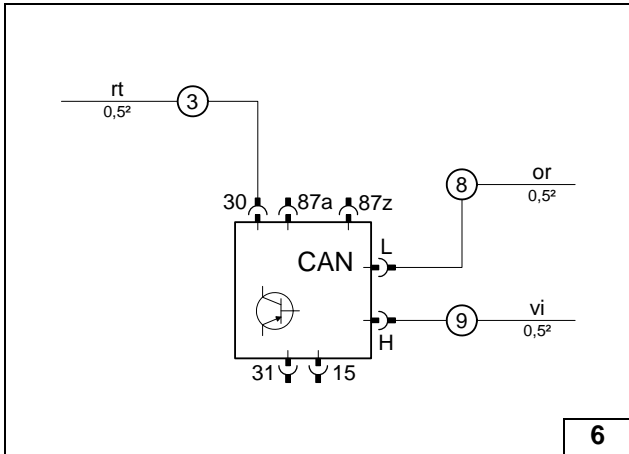

Connect wires to relay socket.



Installing CAN-module

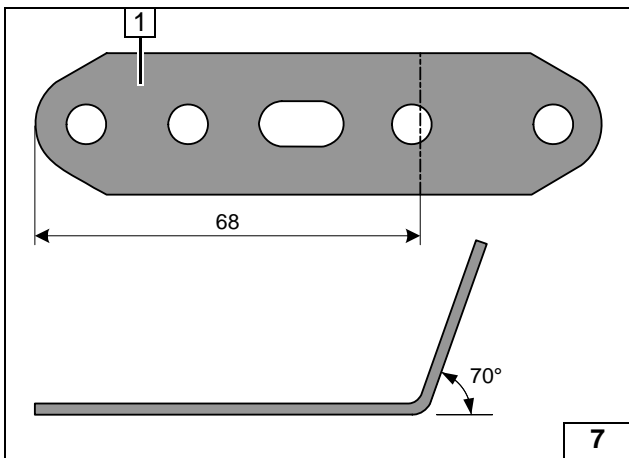

1 Perforated bracket



Angling down perforated bracket

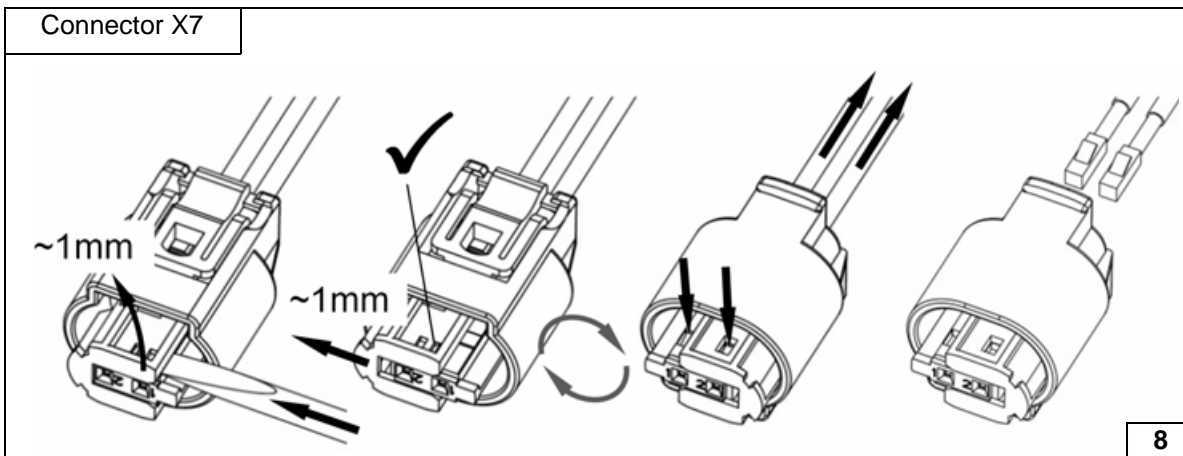

Removing metering pump connector



Electrical System

Fuse holder of engine compartment

Align perforated bracket 1.

- 2 Original vehicle bolt
- 3 M5x16 bolt, windscreen, retaining plate of fuse holder, nut
- 4 Fuses F1-2 (replace 30A fuse with 1A fuse)

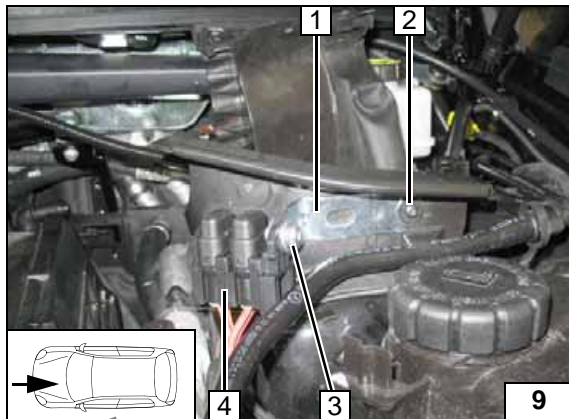

Main fuse F3

When drilling, watch components located behind.

- 1 5.5mm dia. hole, M5x16 bolt, washers, retaining plate of fuse holder, nut
- 2 30A main fuse F3 (insert only during "final work")

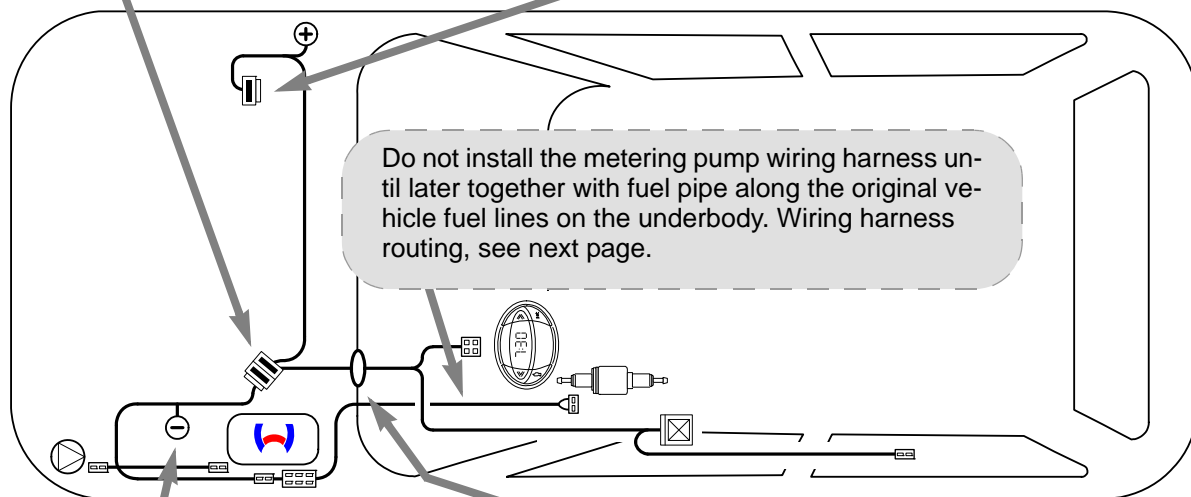
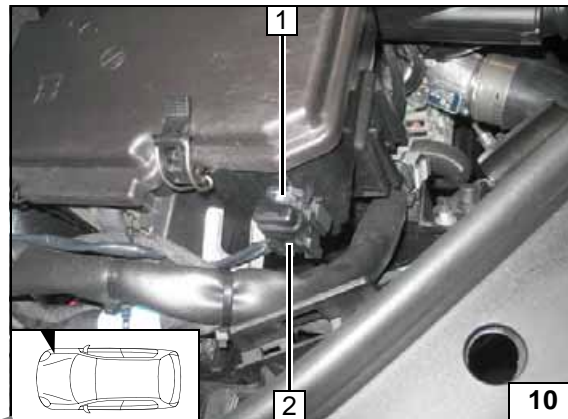

Wiring harness routing diagram

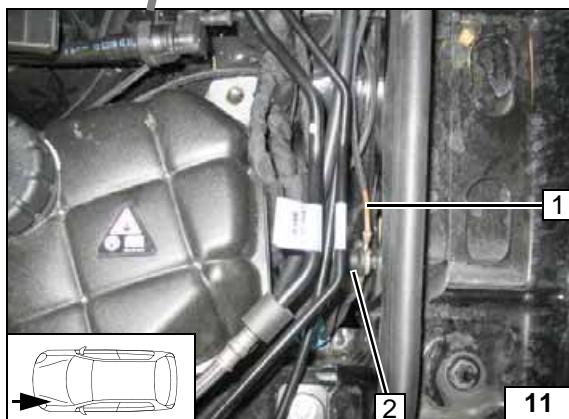

Earth wire

- 1 Earth wire, cable lug
- 2 Original vehicle earth support point

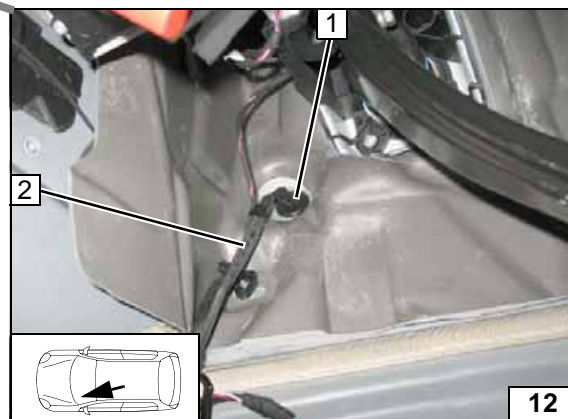

Wiring harness pass through

- 1 Protective rubber plug
- 2 Wiring harnesses of heater, heater control

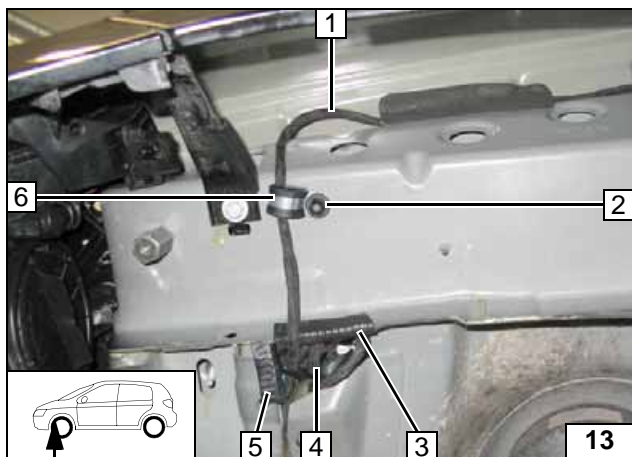

Separate edge protection.

- 1 Wiring harness of heater
- 2 Original vehicle stud bolt, plastic nut
- 3 60mm edge protection
- 4 Original vehicle pass through
- 5 40mm edge protection
- 6 10 mm dia. rubber-coated p-clamp



Routing wiring harness

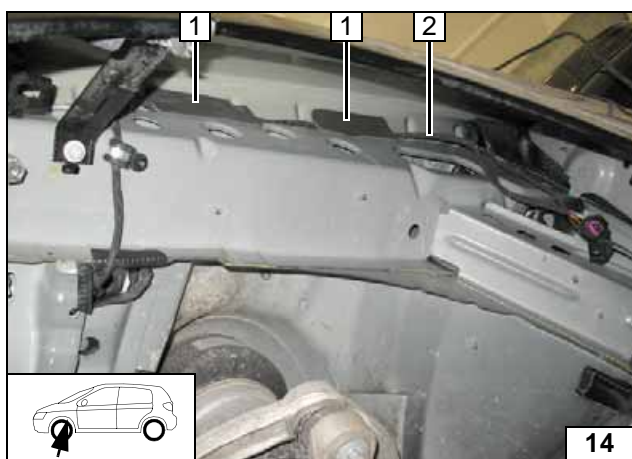

Fasten wiring harness of heater 2 to body using insulation protection strips [2x] 1 .



Routing of heater wiring harness

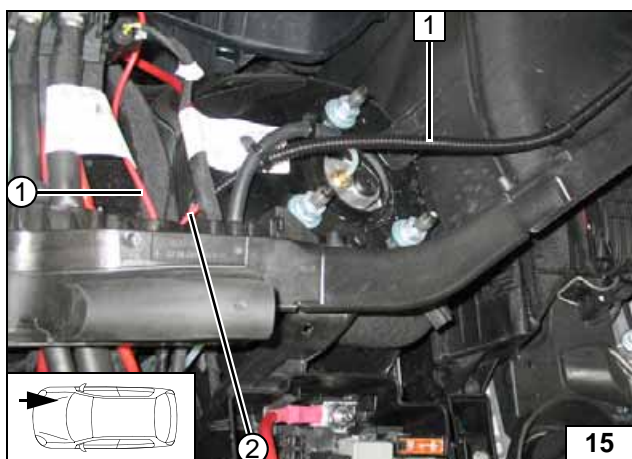

Pull red (rt) wire ② into 6mm dia. corrugated tube 1.

- ① Red (rt) wire of fuse F3, cable lug



Routing lines

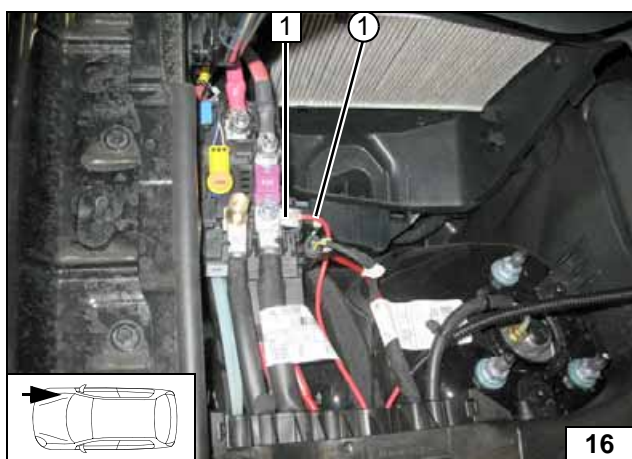

- 1 Original vehicle positive support point
- ① Red (rt) wire of fuse F3, cable lug

Connection of positive extension

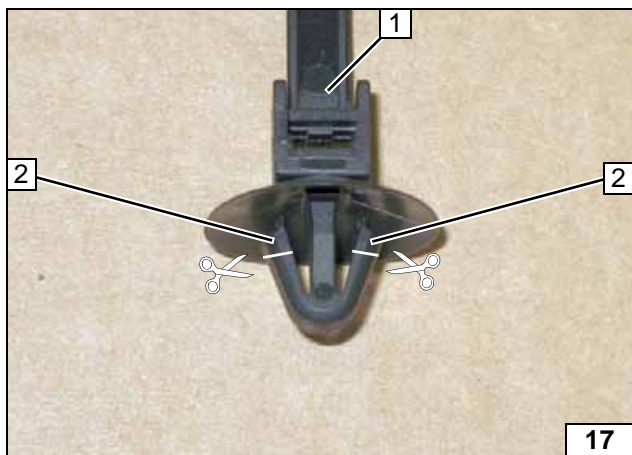

Clip-type cable tie [4x] to fasten corrugated tube of positive extension (two will be used for "electrical system" and two for "final work").



- 1 Shorten clip-type cable tie
- 2 Discard sections

Preparing clip-type cable tie [4x]

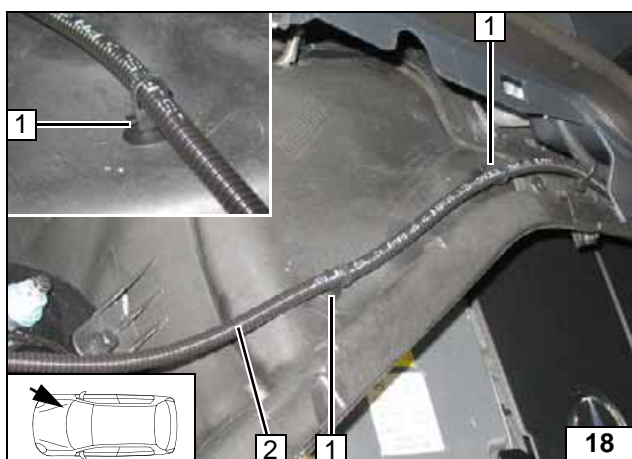

6mm dia. hole [2x] at position 1. When drilling, watch components located behind.



- 1 Clip-type cable tie [2x]
- 2 Red (rt) wire ② in 6mm dia. corrugated tube

Routing positive extension

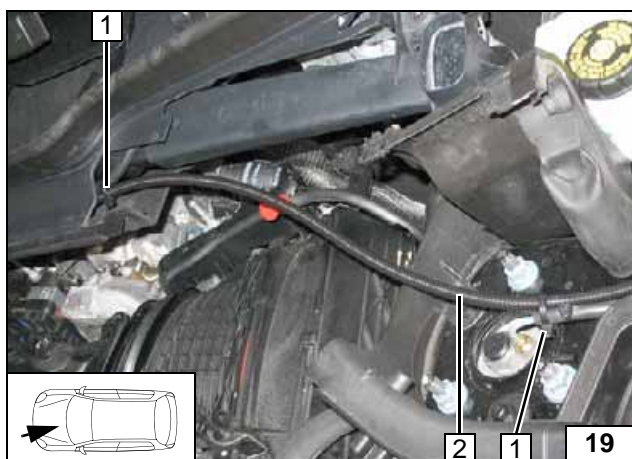

- 1 Cable tie [2x]
- 2 Red (rt) wire ② in 6mm dia. corrugated tube

Routing positive extension

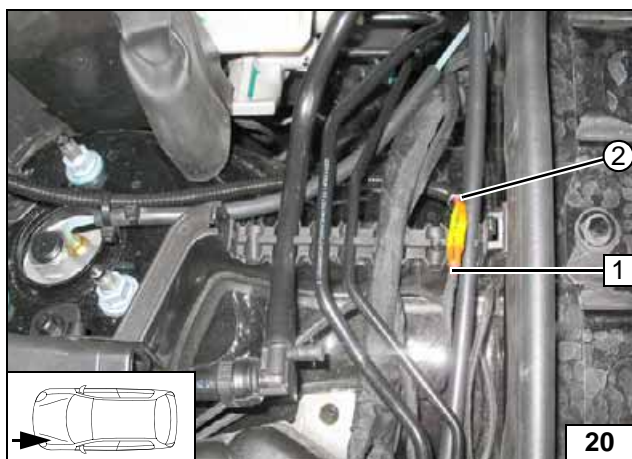

Connect positive wire of heater wiring harness 1 according to wiring diagram with red (rt) wire ② .



Extending positive wire



Fan Controller

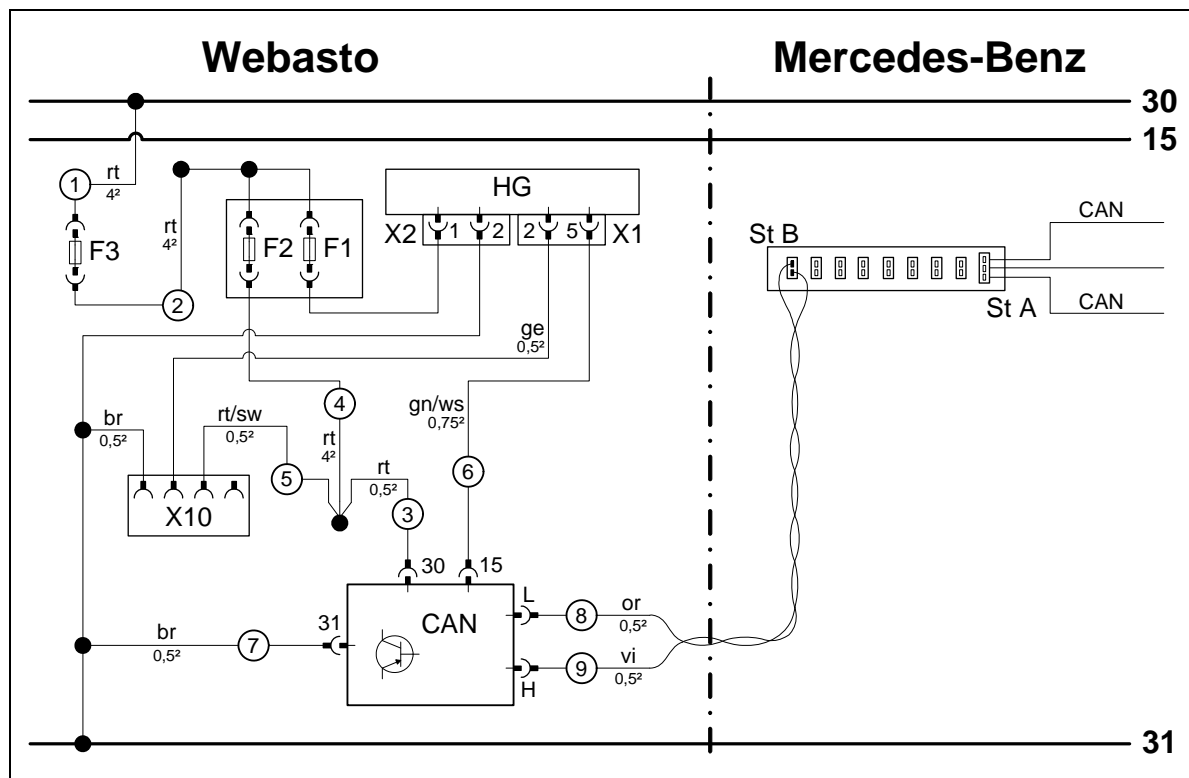

Wiring diagram

Webasto components		Vehicle components		Colours and symbols	
HG	TT-Evo heater	St A	CAN-node	rt	red
X1	6-pin heater connector			sw	black
X2	2-pin heater connector			ge	yellow
F1	20A fuse			gn	green
F2	Replace 30A fuse with 1A fuse.			vi	violet
F3	30A main fuse			ws	white
ST B	Connector of CAN-module			br	brown
X10	4-pin connector of heater control			or	orange
CAN	CAN-module			Wiring colours may vary.	

Legend

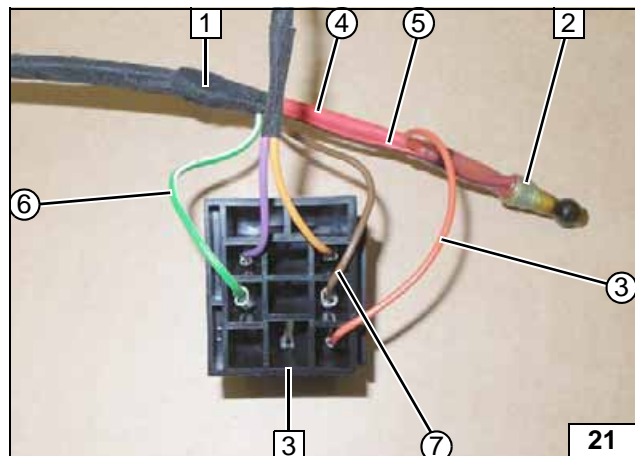

Connect wires ③, ④ and ⑤ to solder wire terminator 2 according to wiring diagram in passenger compartment. Insert wires in relay socket 3.



Connecting wires

- 1 Wiring harness of heater
- ③ Red (rt) wire of SPS CAN-Module/30
- ④ Red (rt) wire of fuse F2
- ⑤ Red/black (rt/sw) wire of connector X10
- ⑥ Green/white (gn/ws) wire of SPS CAN-Module/15
- ⑦ Brown (br) wire of SPS CAN-Module/31

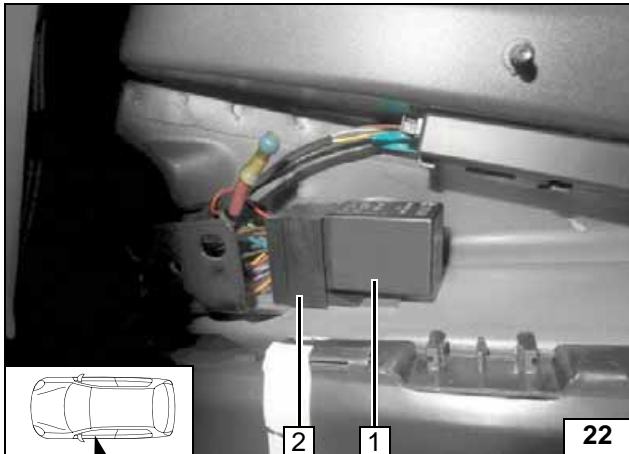

Route wires of CAN-bus ⑧ and ⑨ back below the left door sill cover.

- 1 CAN-Module aufgesteckt mounted
- 2 Fasten CAN-module with adhesive tape



**Connect-
ing wires**

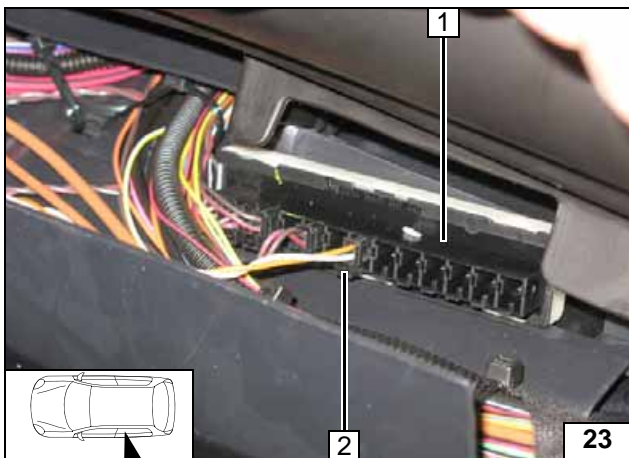

CAN-node is situated below the footwell cover of the left rear bench seat in the direction of the vehicle centre.

Insert connector of CAN-module into free socket. Re-install the door sill cover of the entrance strip in the back left.

- 1 CAN-node
- 2 Connector of CAN-module (St B)



**Connec-
tion of
CAN-bus**

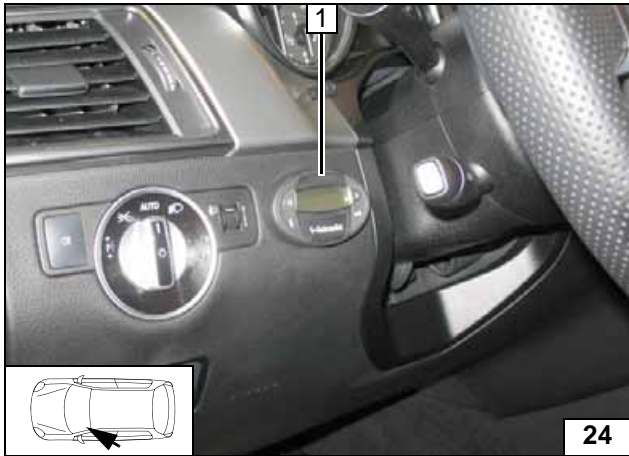

Digital Timer

1 Digital timer



Installing digital timer

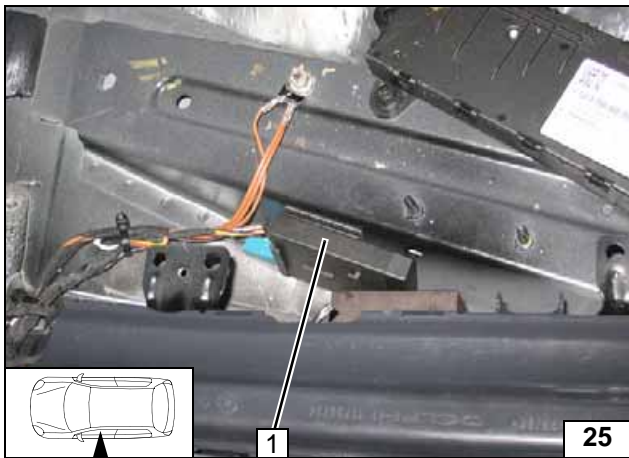

Remote Option (Telestart)

Fasten receiver 1 with adhesive tape.



Installing receiver

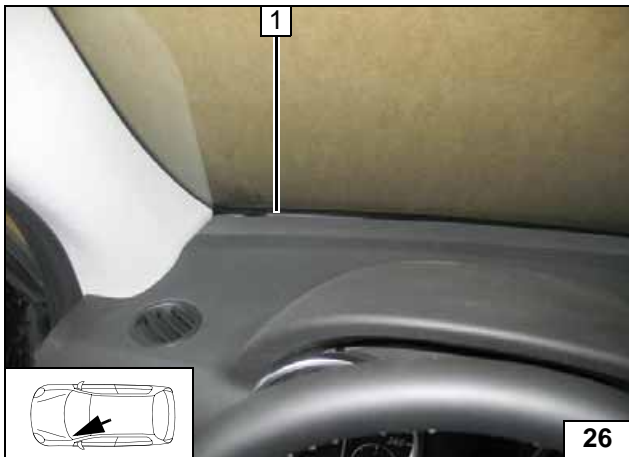

1 Antenna

Installing antenna



Temperature sensor T100 HTM

Fasten temperature sensor 1 with adhesive tape.



Installing temperature sensor

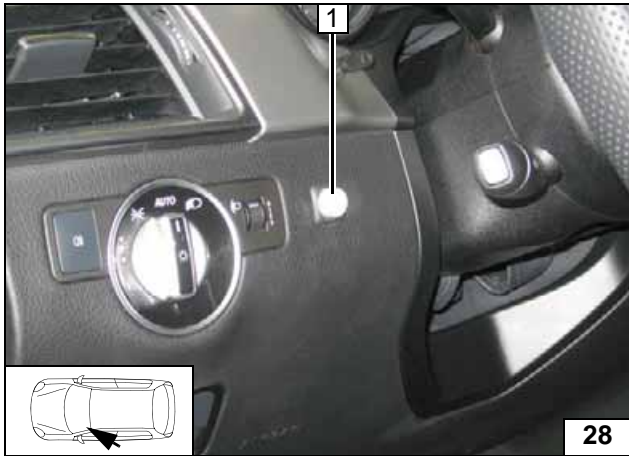

Push button option

- 1 Push button



**Mounting
push but-
ton**

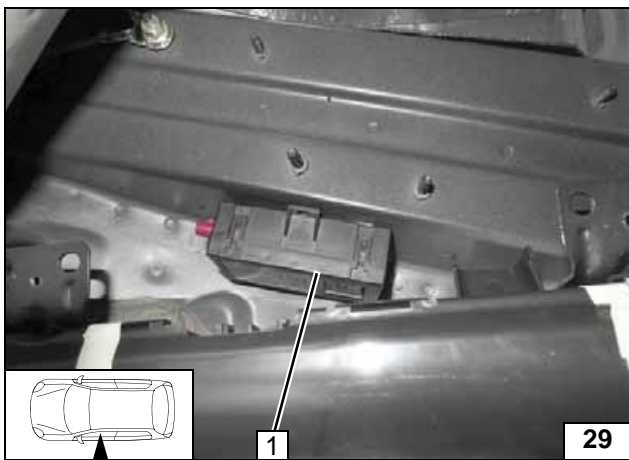

Remote Option (Thermo Call)

Fasten receiver 1 with adhesive tape.



**Installing
receiver**

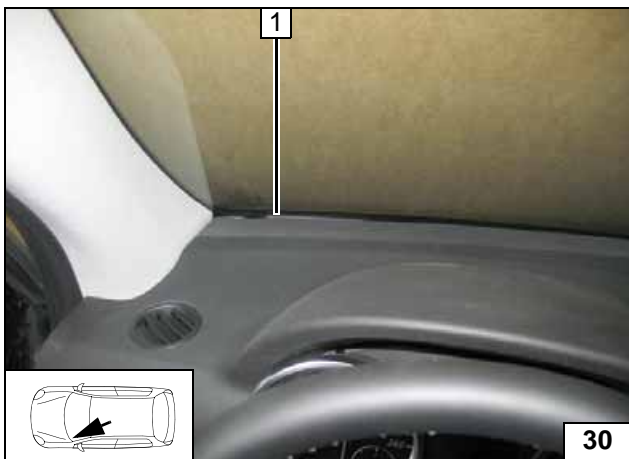

- 1 Antenna

**Installing
antenna**



Preparing Installation Location

Pull off insulation 2 and discard.

- 1 Wheel well trim of left front wheel



Removing insulation

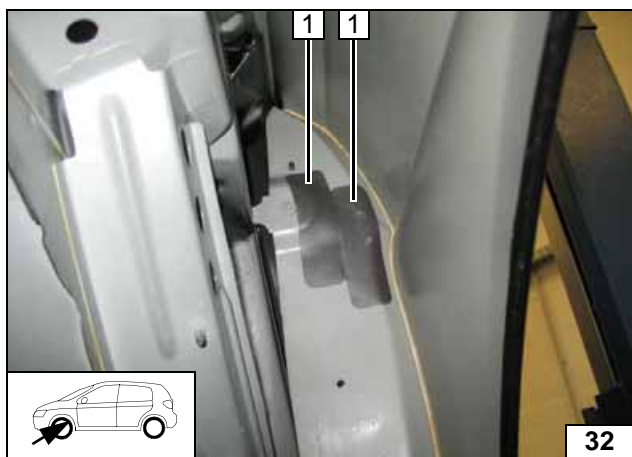

- 1 Insulation protection strips [2x]

Glueing on insulation protection strips

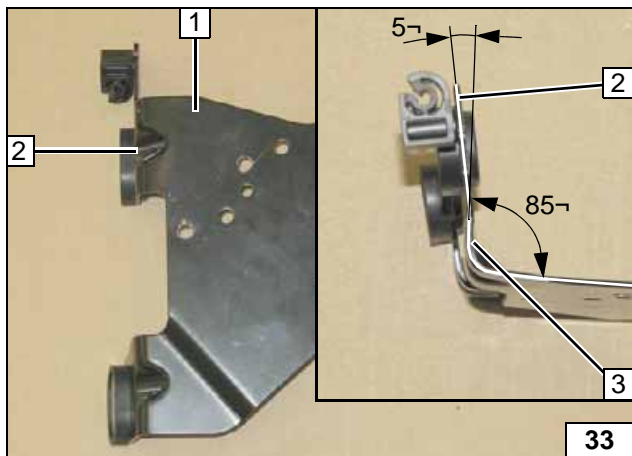

Preparing Bracket

Bend tab inwards at position 3 as shown by about 5° and by about 5° outwards at position 2. Pay attention to the parallelism of the screw points.

- 1 Bracket



Preparing bracket

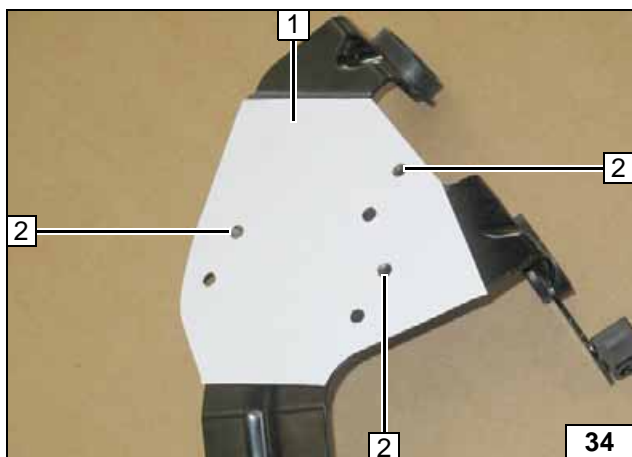

Cut out template 1, place it and align it with the existing holes.

- 2 Copy hole pattern, 5.5mm dia. hole [3x each]



Holes in bracket

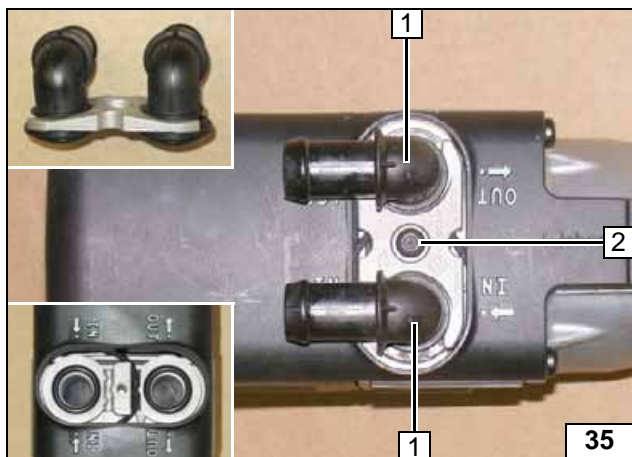

Preparing Heater

- 1 Water connection piece, sealing ring [2x each]
- 2 5x15 self-tapping bolt, retaining plate of water connection piece



Installing water connection piece

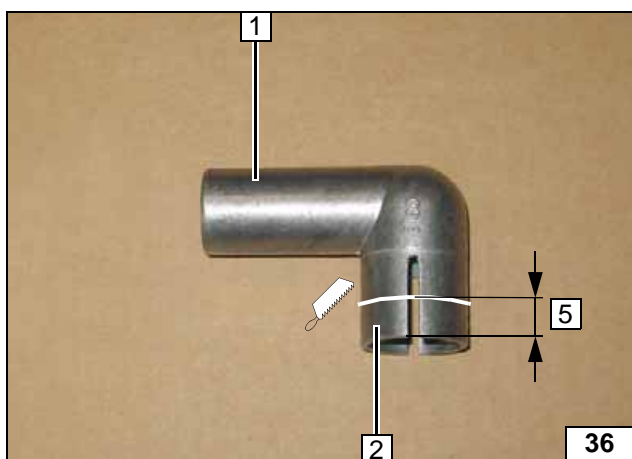

Shorten exhaust elbow 1 on the line shown here.

- 2 Discard section



Shortening exhaust elbow

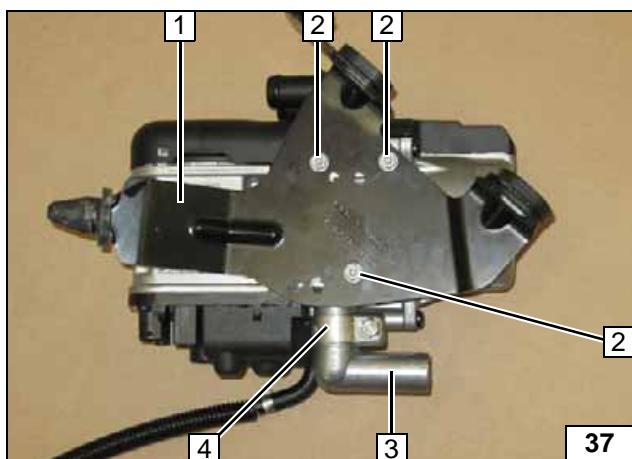

- 1 Bracket of heater
- 2 5x13 self-tapping bolt [3x]
- 3 Exhaust elbow
- 4 Loosely mount hose clamp

Installing bracket

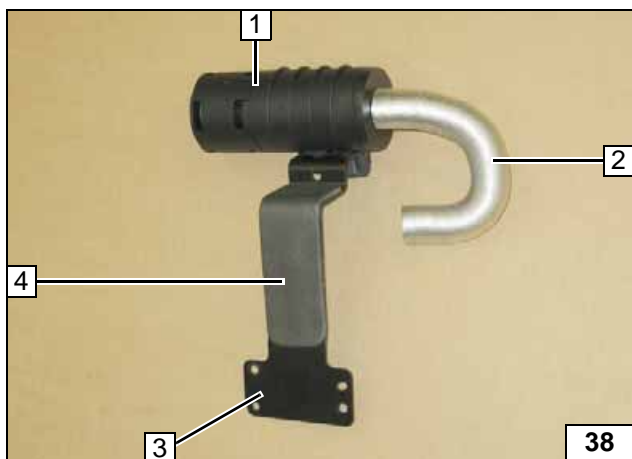

- 1 Combustion air silencer
- 2 180mm combustion air pipe
- 3 Bracket of silencer
- 4 Glue on insulation strip

Premounting bracket of combustion air silencer

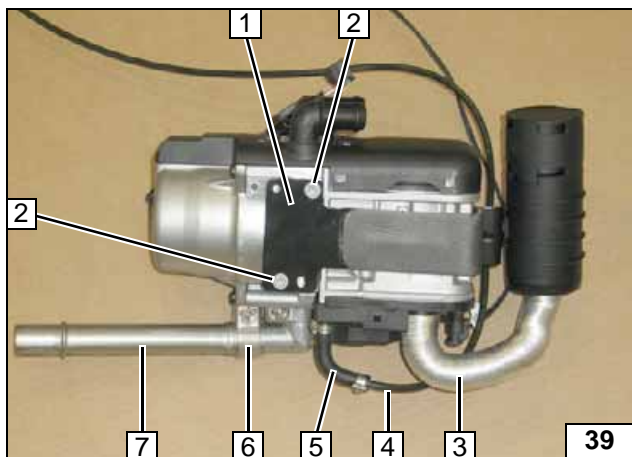

Mind cover of slits at position 6!

- 1 Bracket of silencer
- 2 5x13 self-tapping bolt [2x]
- 3 Combustion air pipe
- 4 Fuel line
- 5 90° moulded hose, 10 mm dia. clamp [2x]
- 6 Hose clamp
- 7 Exhaust pipe



Premounting heater

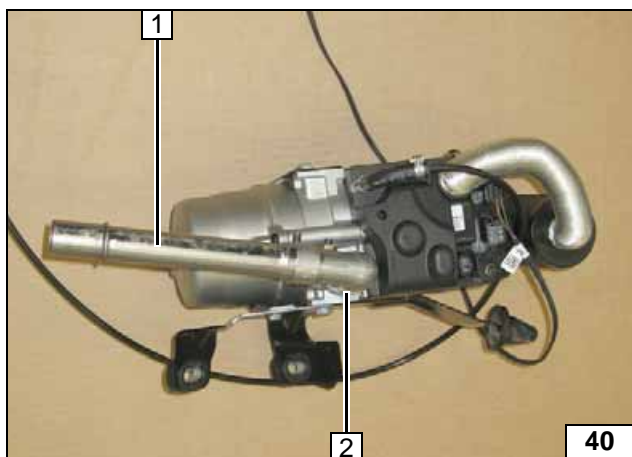

- 1 Exhaust pipe
- 2 Tighten hose clamp

Aligning exhaust pipe

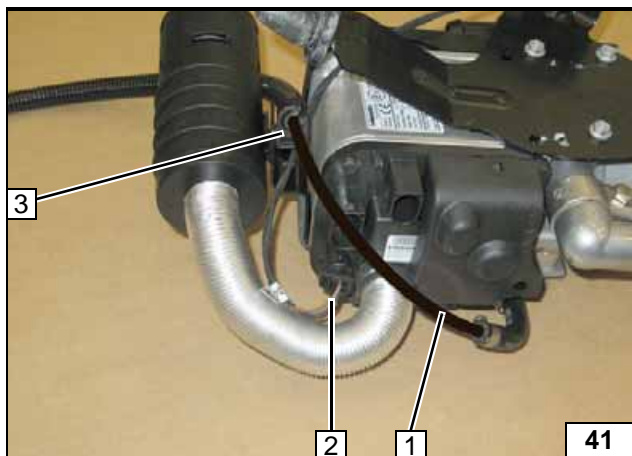

Insert fuel line 1 into retaining clip 3.

- 2 Attach wiring harness of circulating pump



Clamping fuel line

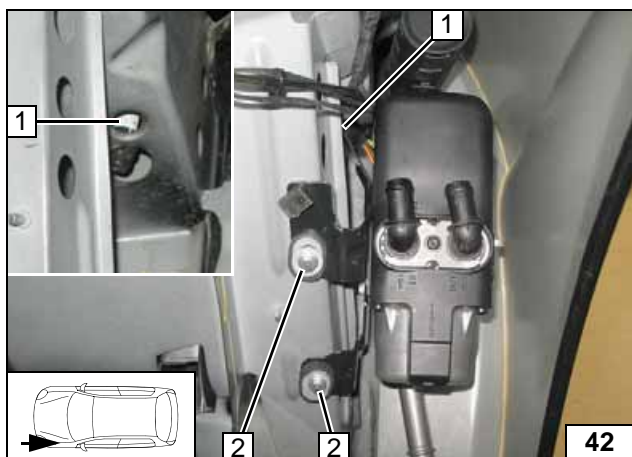

Mounting Heater

Attach wiring harness of heater [2x] prior to installation. Insert rubber bearing in original vehicle hole at position 1. Align heater. Ensure sufficient distance to neighbouring components.

- 2 Original vehicle stud bolt, large diameter washer, M6 flanged nut [2x each]



Installing heater

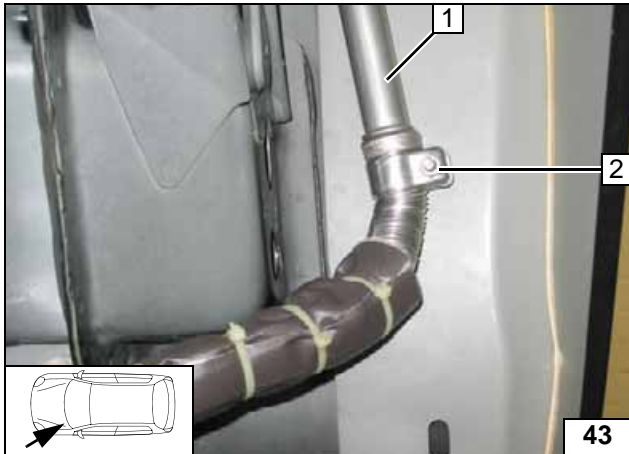
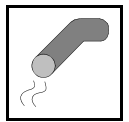

Exhaust Gas

- 1 Exhaust pipe
- 2 Tighten hose clamp

Installing exhaust system

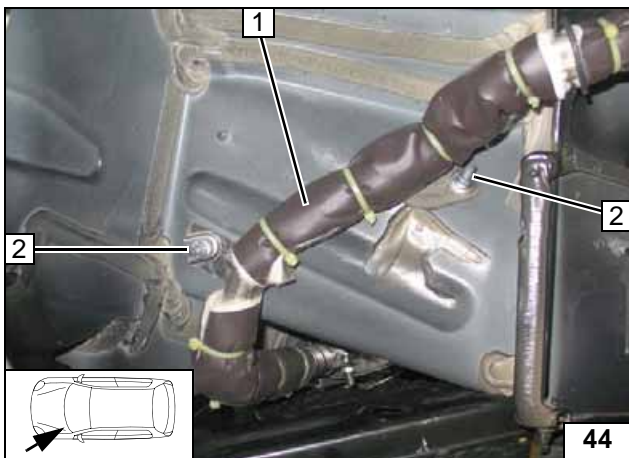

- 1 Exhaust pipe
- 2 Original vehicle stud bolt, bracket of exhaust pipe, M6 flanged nut [2x each]

Mounting exhaust pipe

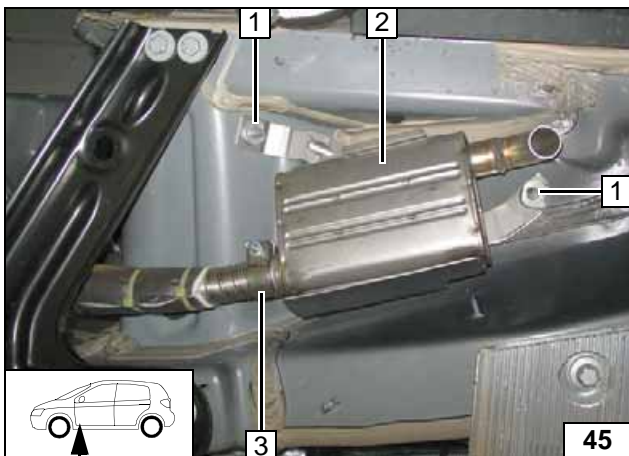

Align silencer **2**. Ensure sufficient distance to neighbouring components.

- 1 Original vehicle stud bolt, black (sw) plate nut 8 [2x each]
- 3 Hose clamp



Installing silencer

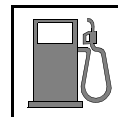

Fuel

CAUTION!

Open the vehicle's fuel tank cap, ventilate the tank and then re-close the tank lock.

Catch any fuel running off in an appropriate container.

Route fuel line and metering pump wiring harness so that they are protected against stone impact. Unless specified otherwise, always fasten using cable ties.

Provide rub protection for fuel line and wiring harness in areas where there are sharp edges.

WARNING!

The fuel line and wiring harness are routed to the metering pump as shown in the wiring harness routing diagram. The colour of the fuel line may differ.

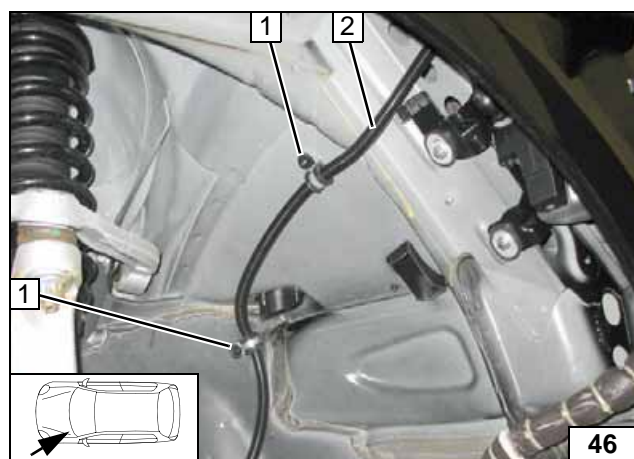

Pull fuel line and wiring harness of metering pump into 10mm dia. corrugated tube **2**.

- 1 Original vehicle stud bolt, rubber coated
15mm dia. p-clamp, plastic nut [2x each]



Routing in wheel well

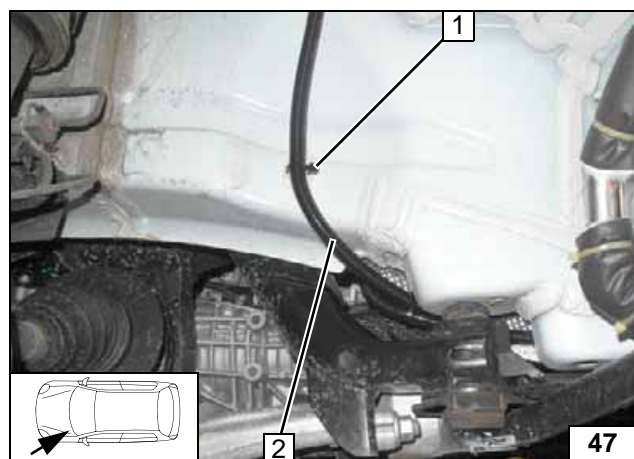

Clean adhesion surface prior to glueing. Route fuel line and wiring harness of metering pump in 10mm dia. corrugated tube **2** behind the heat guard plate to the rear.

- 1 Adhesive base, cable tie



Routing in wheel well

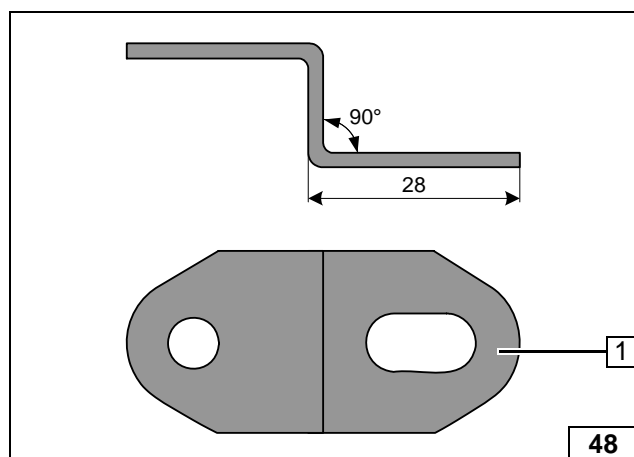

- 1 Angle bracket



Preparing angle bracket

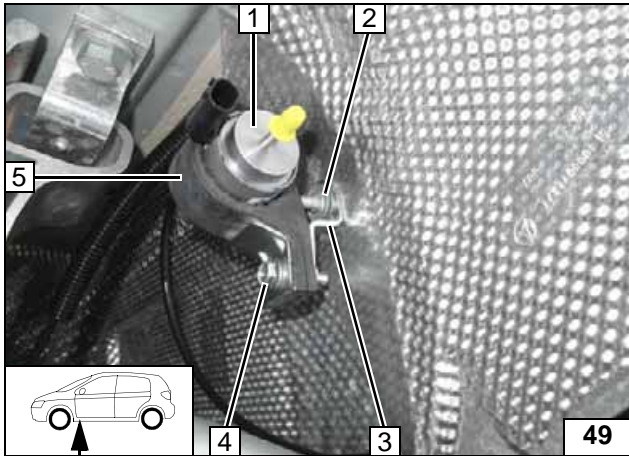
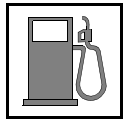

- 1 Metering pump
- 2 Original vehicle stud bolt, original vehicle nut
- 3 Angle bracket
- 4 M6x25 bolt, support angle bracket, flanged nut
- 5 Metering pump support

Mounting metering pump

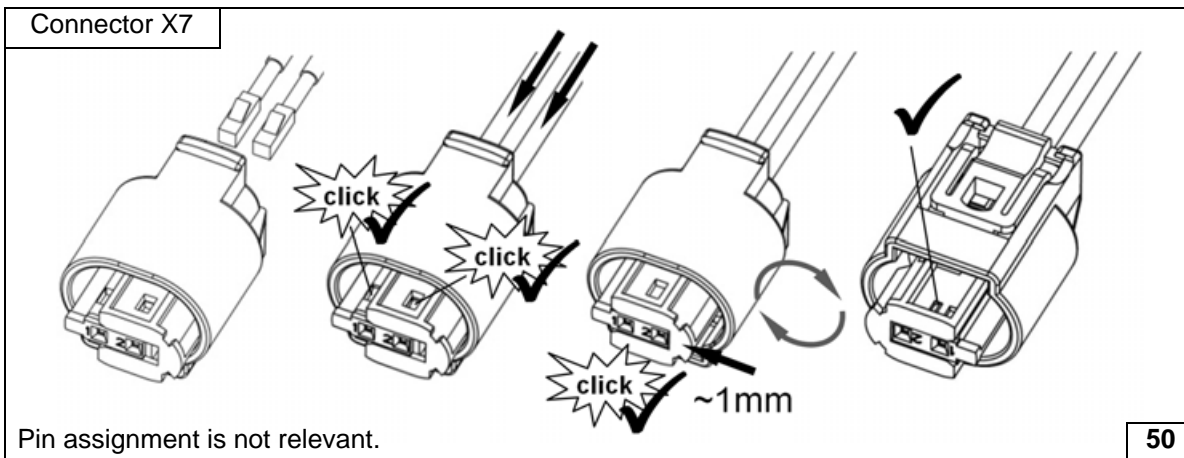

Completing connector of metering pump

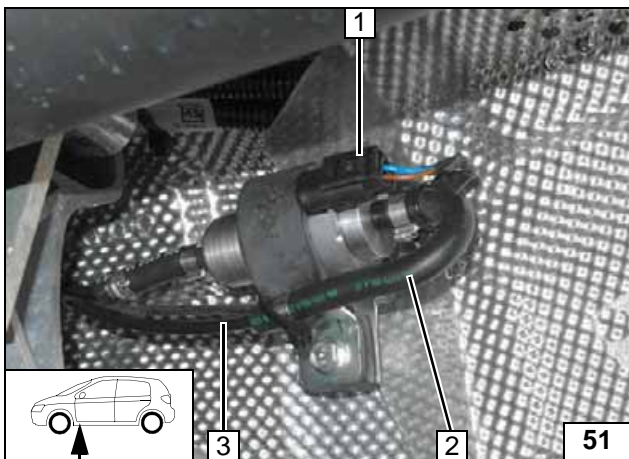

- 1 Wiring harness of metering pump, connector mounted
- 2 180° moulded hose, 10 mm dia. clamp [2x]
- 3 Fuel line of heater (cut to length)



Connection of metering pump

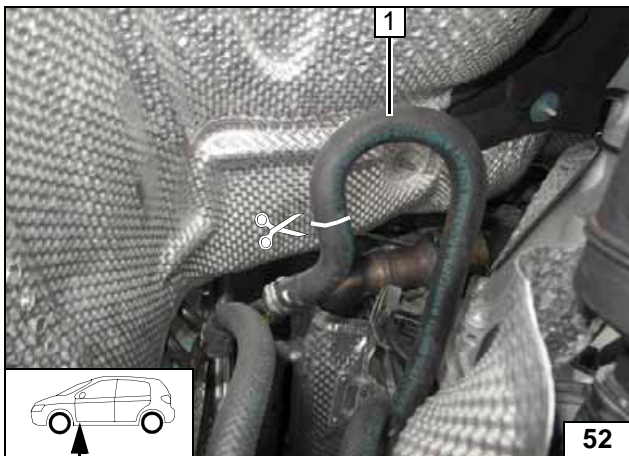

Separate fuel return line 1 along the marking!



Fuel extraction

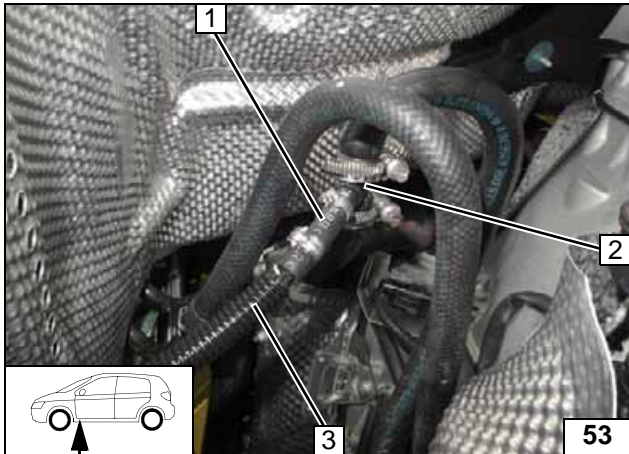
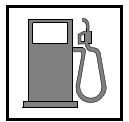

Route fuel line in 10mm dia. corrugated tube 3 behind the heat guard plate to the rear.

- 1 Hose section, 10 mm dia. clamp [2x]
- 2 12x5x12mm fuel standpipe, 16-27mm dia. hose clamp [2x]



Installing fuel stand pipe

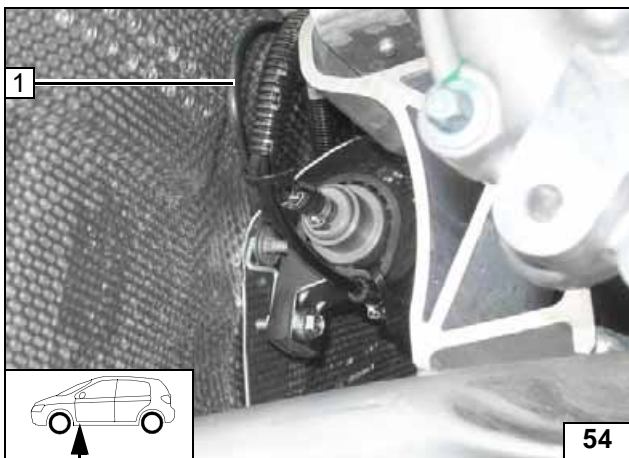

- 1 Fuel line of fuel standpipe

Routing to the metering pump

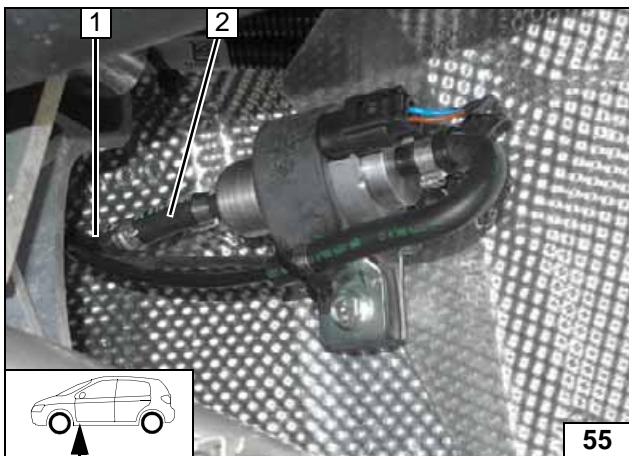

Check the position of the components; correct if necessary. Check that they have freedom of movement.

- 1 Fuel line of fuel standpipe
- 2 Hose section, 10 mm dia. clamp [2x]



Connection of metering pump

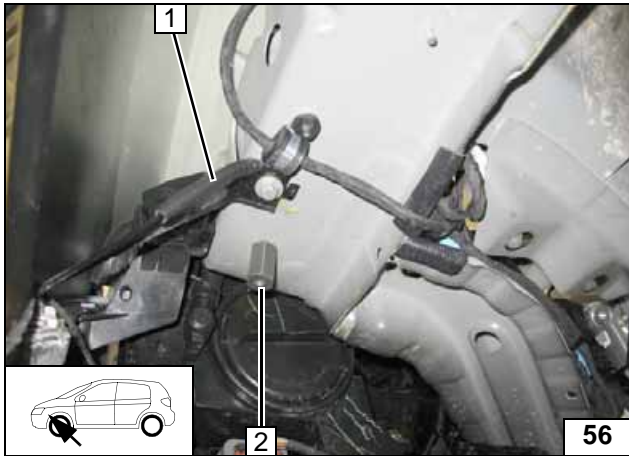

- 1 100mm edge protection
- 2 Original vehicle stud bolt, M6x30 spacer nut

Installing edge protection

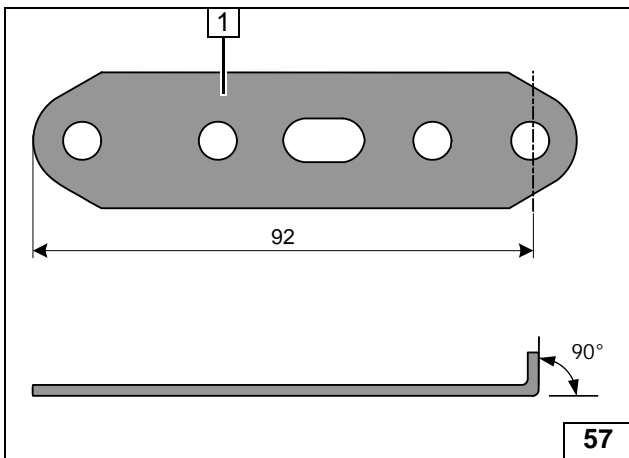

- 1 Perforated bracket



Angling down perforated bracket

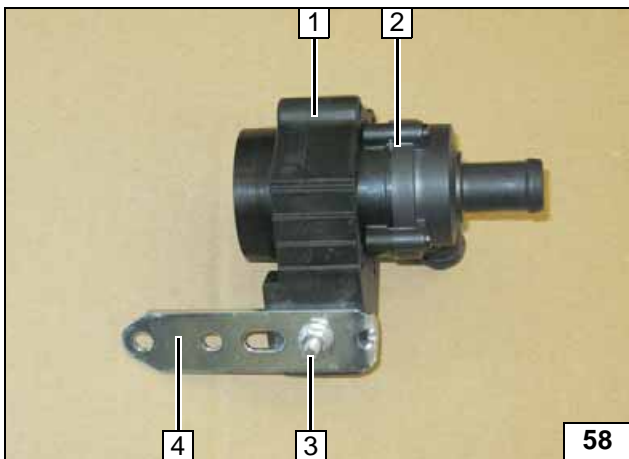

- 1 Circulating pump support
- 2 Circulating pump
- 3 M6x25 bolt, flanged nut
- 4 Perforated bracket

Premounting circulating pump

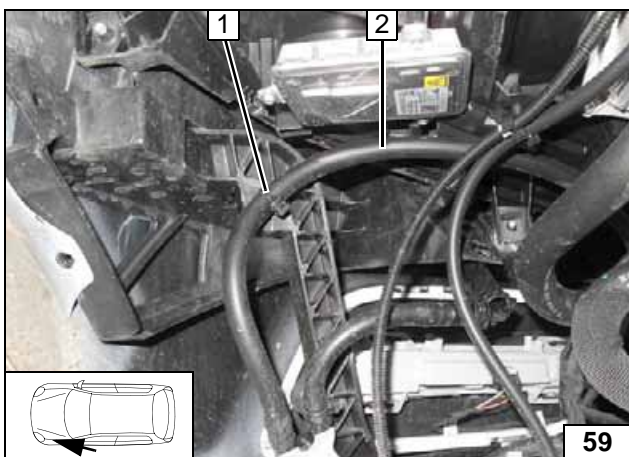

- 1 Detach clip-type cable tie
- 2 Hose of headlight washer system

Detaching clip-type cable tie

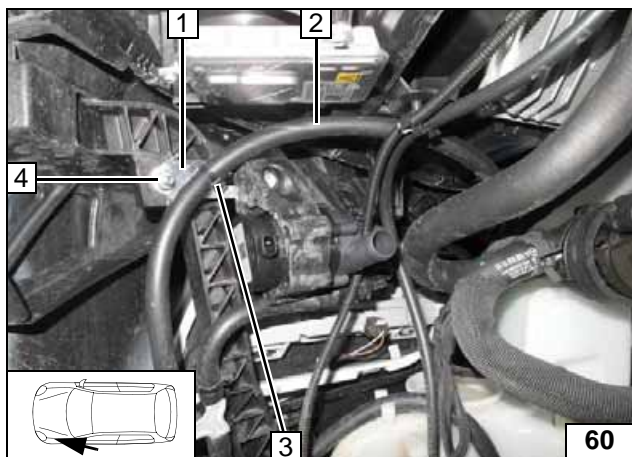

- 1 Perforated bracket
- 2 Hose of headlight washer system
- 3 Clip-type cable tie, existing hole of perforated bracket
- 4 M6x20 bolt, large diameter washer, flanged nut, existing hole

Installing circulating pump

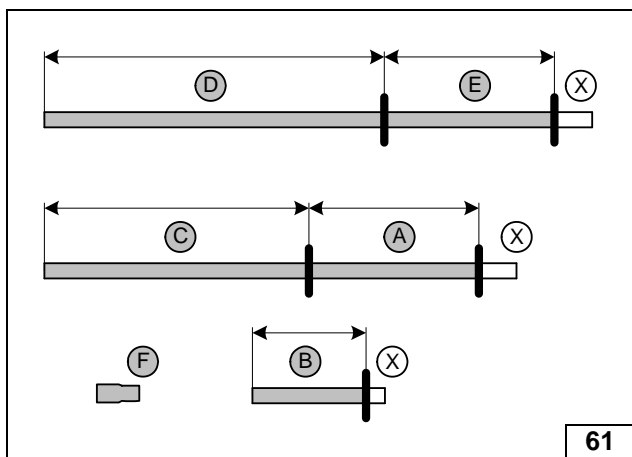

Discard section X.
Hose F = 18x20mm dia. moulded hose

- A = 750
- B = 390
- C = 1045
- D = 1250
- E = 760



Cutting hoses to length

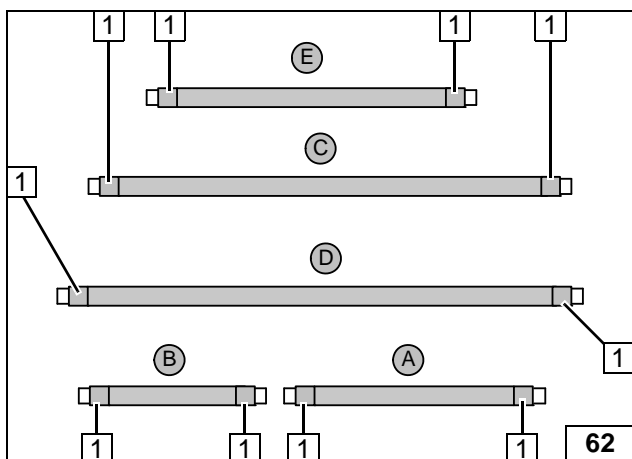

Slide braided protection hoses onto hoses A to E and cut to length.
Cut heat shrink plastic tubing to size.

- 1 Heat shrink plastic tubing, 25mm long [10x]



Preparing hoses

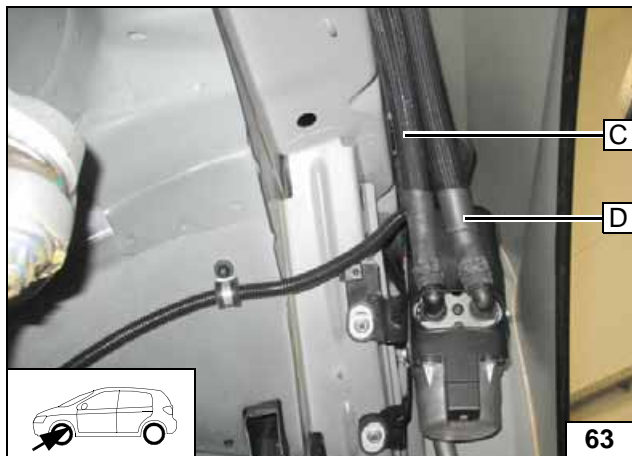

Connection heater

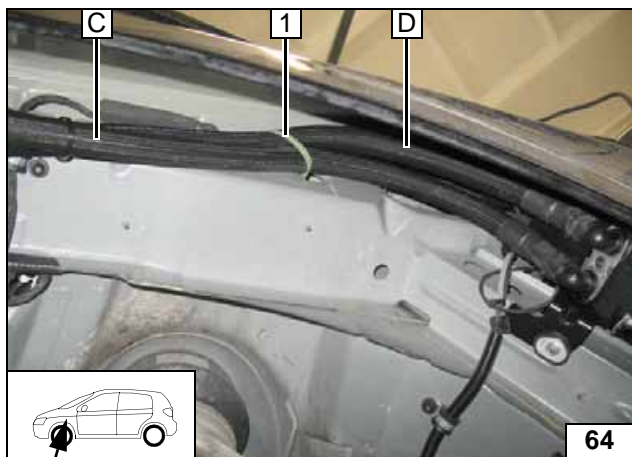
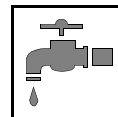

Fasten hoses **C** and **D** white (ws) cable tie **1** to existing holes of wheel well using white (ws) cable ties.



Routing wheel well

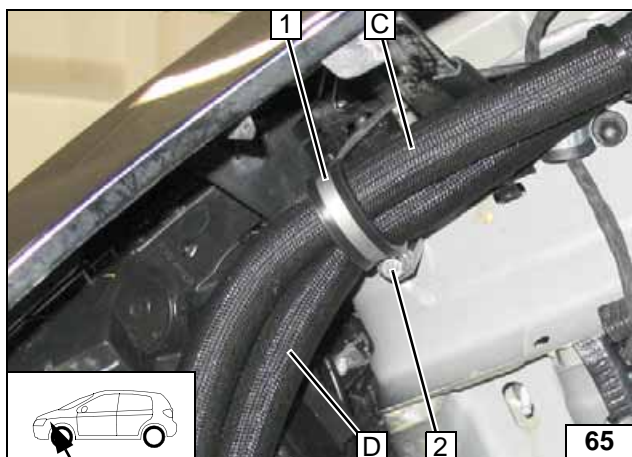

Route hoses **C** and **D** through rubber-coated 38mm dia. p-clamp **1**.

2 M6x16 bolt, spring lockwasher



Routing wheel well

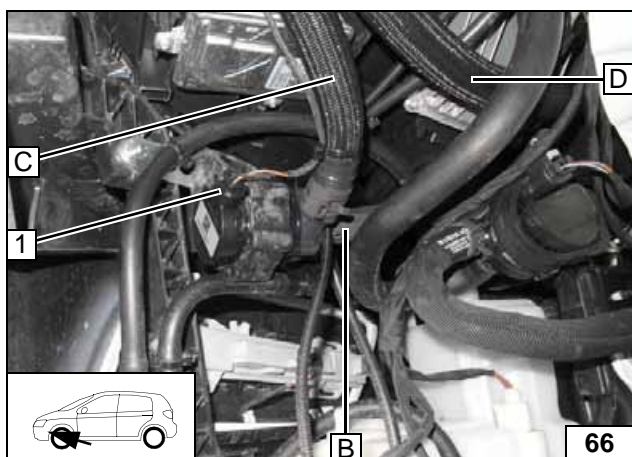

Route wiring harness of circulating pump **1** along hose **C** and attach it to the circulating pump. Route hoses **B** and **D** to the engine compartment.



**Connec-
tion circu-
lating
pump**

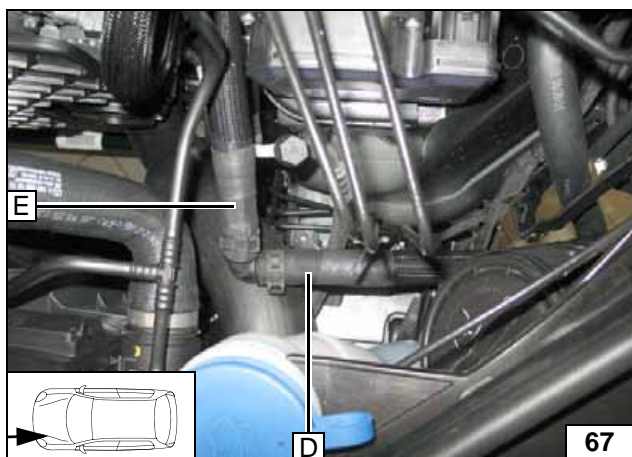

**Connect-
ing hoses D
and E**

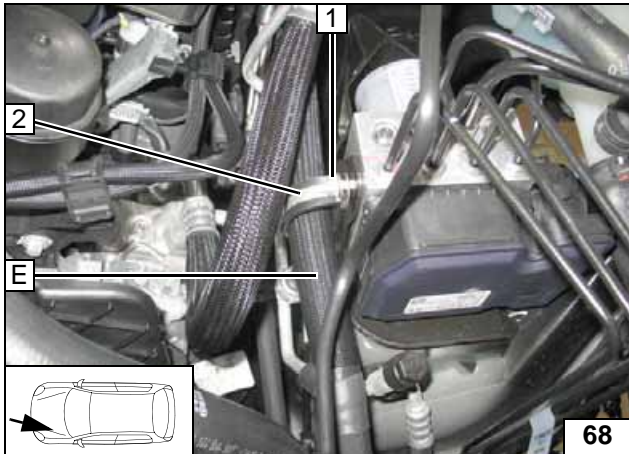

- 1 Original vehicle bolt
- 2 Loosely install 38mm dia. rubber-coated p-clamp

Routing in engine compartment

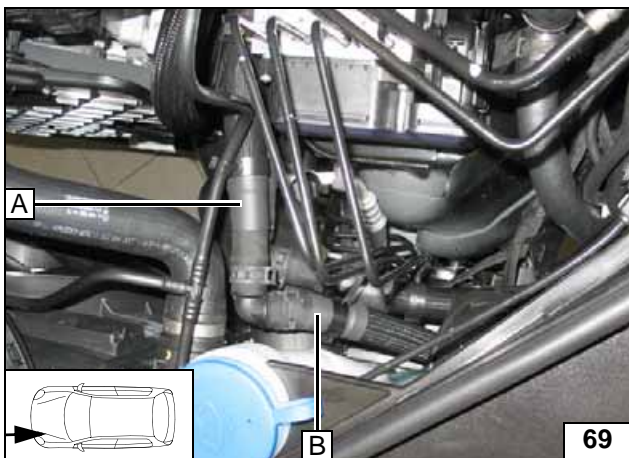

Connecting hoses A and B

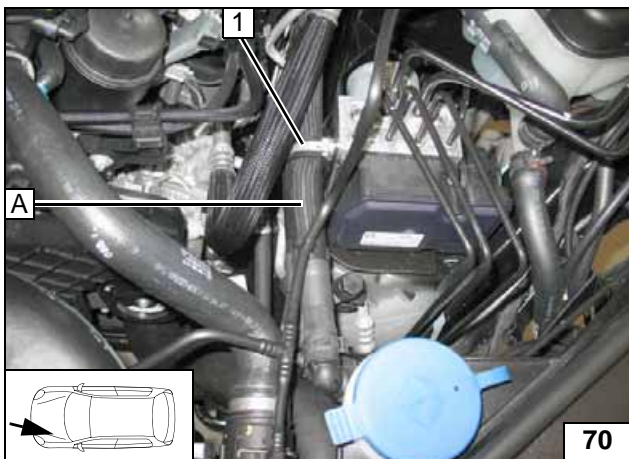

Route hose A through rubber-coated 38mm dia. p-clamp 1 .



Routing in engine compartment

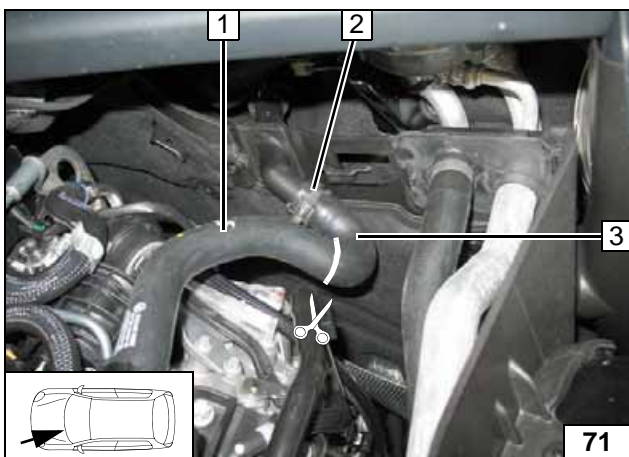

Cut hose of engine outlet / heat exchanger inlet at the marking. Remove hose section of heat exchanger inlet 3 and discard it. Spring clip 2 will be reused.



- 1 Engine outlet hose section

Cutting point

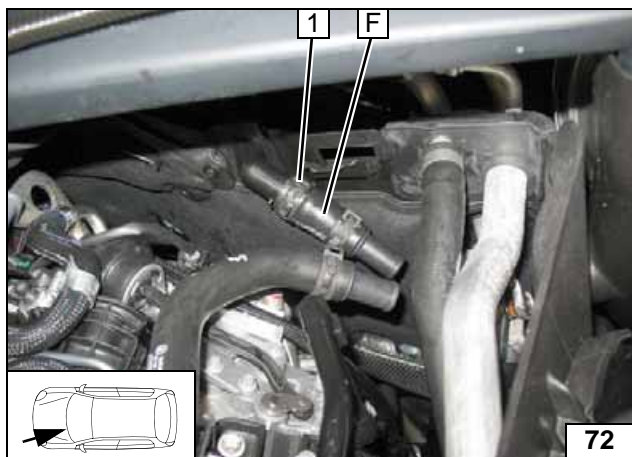

Install connecting pipes.

- 1 Original vehicle spring clip



Connec-
tion of heat
exchanger
inlet

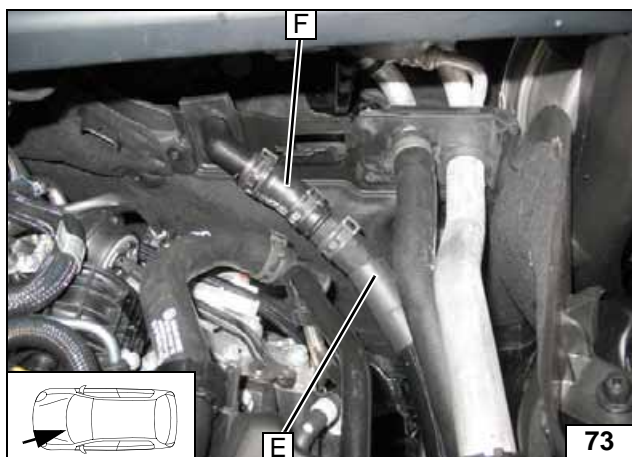

Connect-
ing hoses E
and F

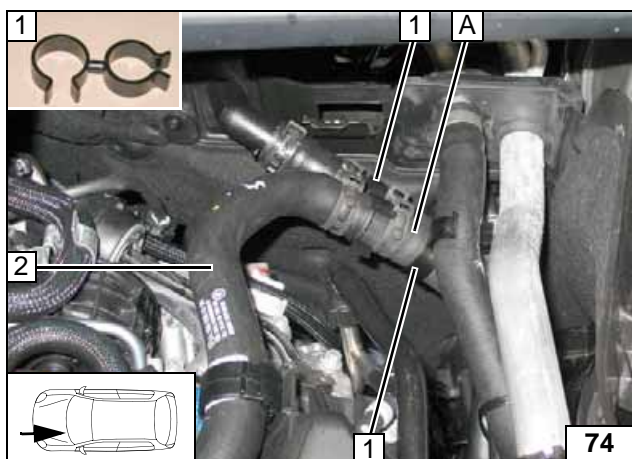

- 1 Hose bracket [2x]
- 2 Hose of engine outlet

Connec-
tion of en-
gine outlet

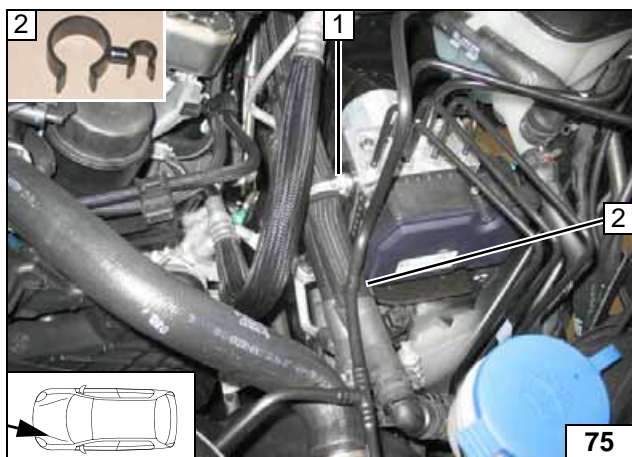

Align hoses. Ensure sufficient distance to neighbouring components.

- 1 Tighten bolt
- 2 Hose bracket



Inserting
hose
bracket

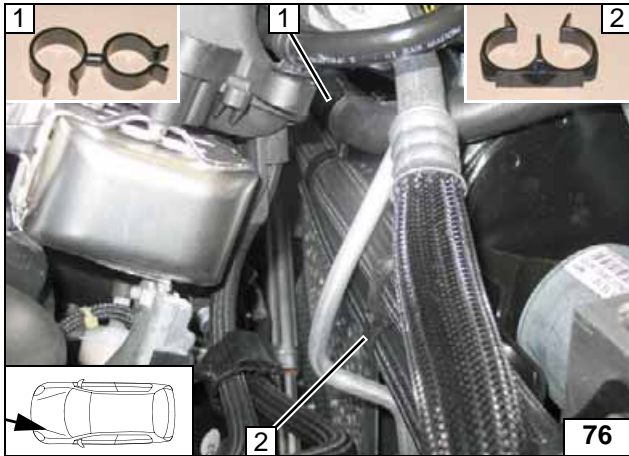

- 1 Hose bracket
- 2 Hose bracket

Inserting
hose
bracket

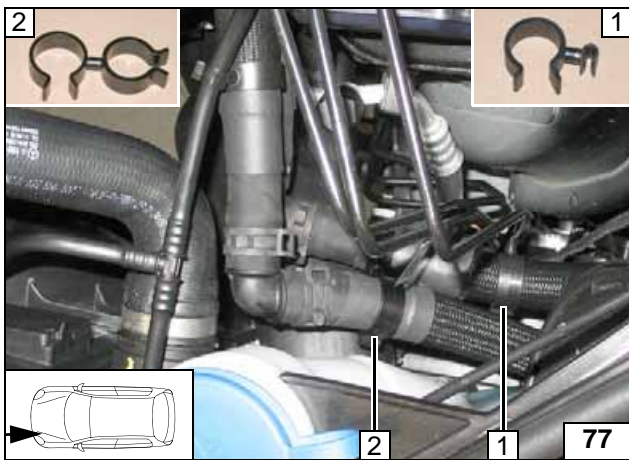

- 1 Hose bracket
- 2 Hose bracket

Inserting
hose
bracket

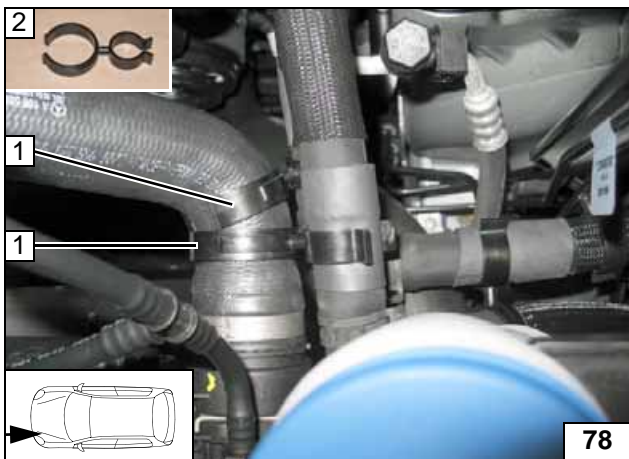

- 1 Hose bracket [2x]

Inserting
hose
bracket

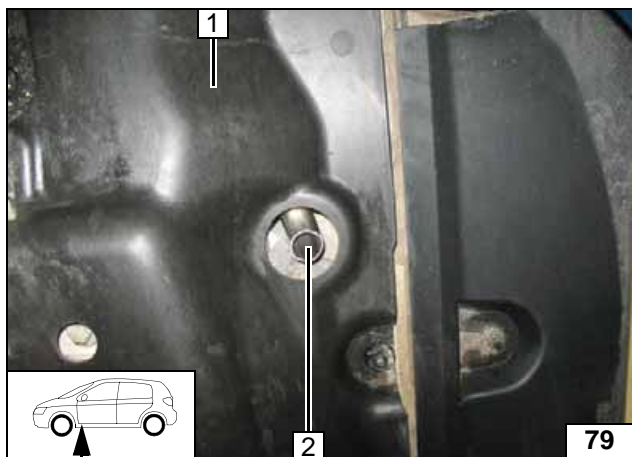

Final Work

Ensure sufficient distance from neighbouring components, correct if necessary.

- 1 Underride protection mounted
- 2 Exhaust end section



Aligning exhaust end section

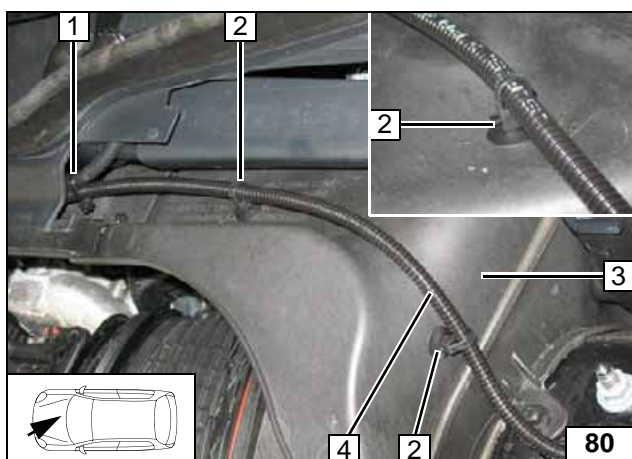

6mm dia. hole [2x] at position 2. When drilling, watch components located behind.

- 1 Cable tie
- 2 Clip-type cable tie [2x]
- 3 Trim mounted
- 4 Red (rt) wire in 6mm dia. corrugated tube



Fastening positive extension

WARNING!

Reassemble the disassembled components in reverse order. Check all hoses, clamps and all electrical connections for firm seating. Insulate and tie back all loose wires.

Only use manufacturer-approved coolant. Spray the heater components with anti-corrosion wax (Tectyl 100K, Order No. 111329).



- **Connect the battery.**
- **Inserting 30A main fuse F3**
- **Fill and bleed the coolant circuit according to the vehicle manufacturer's instructions.**
- **Adjust digital timer, teach Telestart transmitter**
- **Place caution label "Switch off parking heater before refuelling" in the area of the filler neck.**
- **For initial start-up and function check, see installation instructions**



Webasto Thermo & Comfort SE
 Postfach 1410
 82199 Gilching
 Germany
 Internet: www.webasto.com
 Technical Extranet:
<http://dealers.webasto.com>



Drilling Template of Bracket

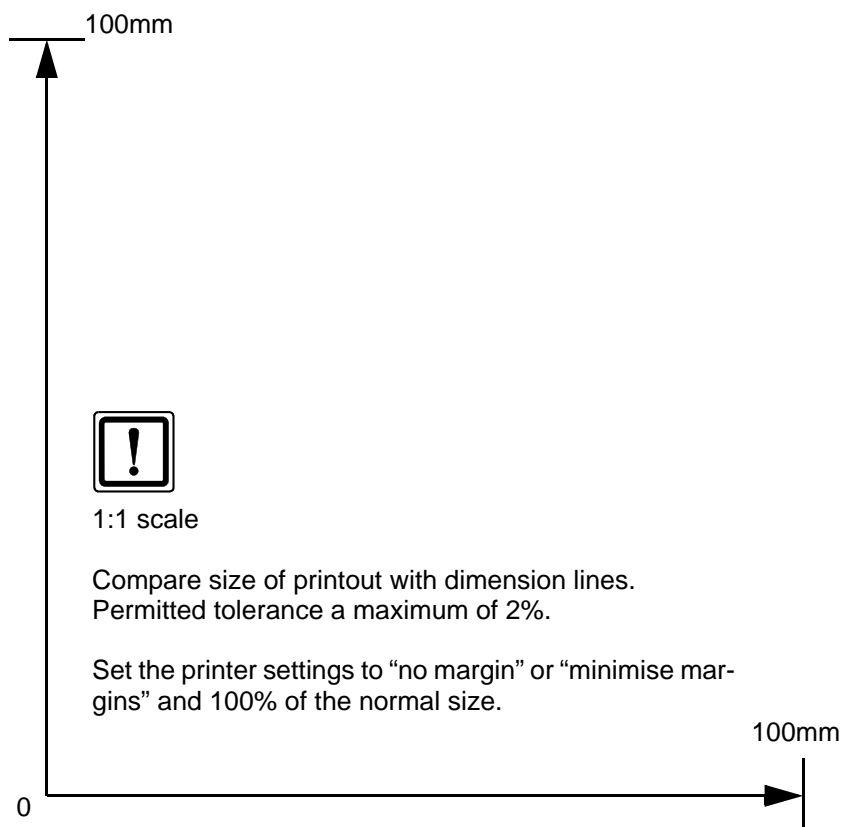
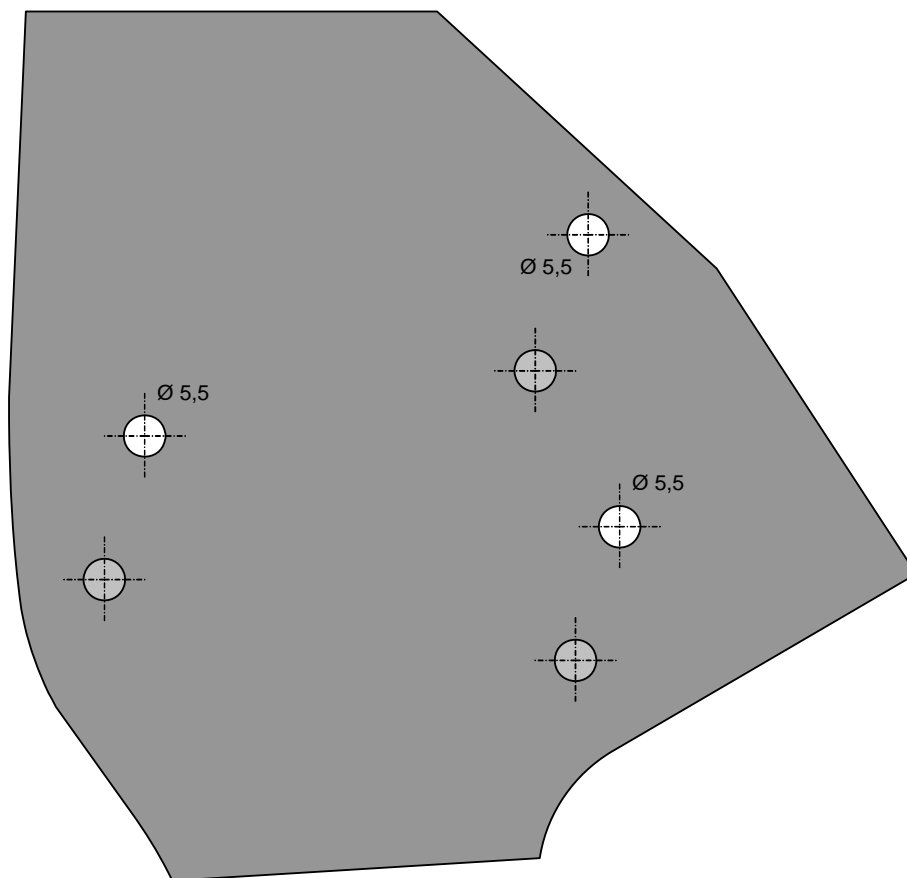

Operating Instructions for End Customer

Please remove page and add to the vehicle operating instructions.

Note:

We recommend matching the heating time to the driving time.

Heating time = driving time

Example:

For a driving time of approx. 20 min. (in one direction), we recommend not exceeding a switch-on time of 20 min.

To guarantee the proper operation of the parking heater, fill the fuel tank at least to a quarter.

If vehicles have passenger compartment monitoring, this must be deactivated in addition to vehicle settings for the heating operation.

Deactivation instructions can be found in the operating instructions of the vehicle.

The following settings are to be made prior to turning off the vehicle in order to improve heating.



- 1 Set temperature on both sides to "HI"

A/C control panel

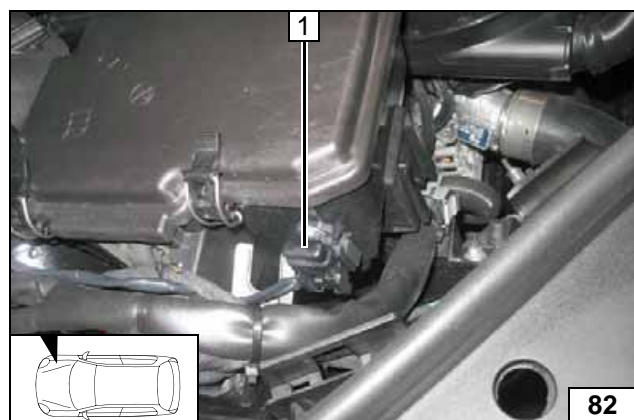

- 1 30A main fuse F3

Engine compartment main fuse

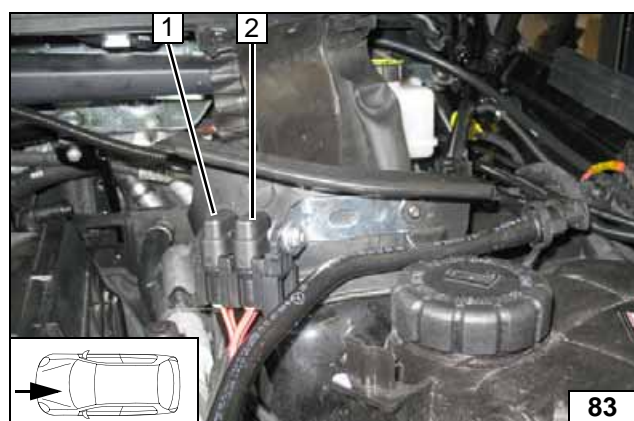

- 1 20A heater fuse F1
- 2 1A fuse F2 of heater control

Fuses of engine compartment

