



Water Heater

Thermo Top Evo 5+ Parking Heater



With FuelFix

Installation Documentation Hyundai Santa Fe / Grand Santa Fe

Validity

Manufacturer	Model	Type	EG BE No. / ABE
Hyundai	Santa Fe	DM	e11 * 2007 / 46 * 0633 *
Hyundai	Grand Santa Fe	NC	e11 * 2007 / 46 * 0633 *02..*

Motorisation	Fuel	Transmission type	Output in kW	Displacement in cm ³	Engine code
2.0 CRDi	Diesel	6-speed SG	110	1995	D4HA
2.2 CRDi	Diesel	6-speed SG	145	2199	D4HB
2.2 CRDi	Diesel	6-speed AG	145	2199	D4HB
2.2 CRDi blue	Diesel	6-speed AG	147	2199	D4HB

SG = manual transmission
AG = automatic transmission

From model year 2013
Left-hand drive vehicle

Verified equipment variants: Automatic air-conditioning
Headlight washer system
Front fog lights
LED daytime running lights
Xenon
2 WD / 4 WD
Alarm system without passenger compartment monitoring

Not verified: Manual A/C system

Total installation time: approx. 8 hours

Hyundai Santa Fe / Grand Santa Fe

Table of Contents

Validity	1	Preparing Installation Location	13
Necessary Components	2	Preparing Heater	15
Installation Overview	2	Installing Heater	16
Information on Total Installation Time	2	Combustion Air	18
Information on Operating and Installation Instructions	3	Exhaust Gas	19
Information on Validity	4	Coolant Circuit	23
Technical Information	4	2.0 D / 2.2 D Only Front Heat Exchanger and SG	23
Explanatory Notes on Document	4	2.2 D Only Front Heat Exchanger and AG	28
Preliminary Work	5	2.2 D with Front / Rear Heat Exchanger and AG	32
Heater Installation Location	5	Fuel	37
Preparing Electrical System	6	Installing FuelFix	38
Electrical System	8	Final Work	42
Fan Controller	9	Fuel Tank Sending Unit Template	44
MultiControl CAR Option	11	FuelFix Template	45
Remote Option (Telestart)	11	Operating Instructions up to Model Year 2014	46
Thermo Call Option	12	Operating Instructions from Model Year 2015	47

Necessary Components

- Basic delivery scope of Thermo Top Evo 5+ based on price list
- Installation kit with FuelFix for Hyundai Santa Fe / Grand Santa Fe 2013 Diesel: **1318738D**
- Heater control in accordance with price list and upon consultation with end customer
- In case of Telestart, indicator lamp in accordance with price list and in consultation with end customer

Installation instructions:

- Arrange for the vehicle to be delivered with the tank only about $\frac{1}{4}$ full.
- The installation location of the push button in case of Telestart or Thermo Call should be confirmed with the end customer.
- Depending on the space required and the vehicle manufacturer's instructions, we recommend the use of a vehicle battery with a higher electrical capacity.

Installation Overview

Legend:

1. Heater
2. Engine compartment fuse holder
3. Passenger compartment relay and fuse holder
4. Circulating pump
5. MultiControl CAR
6. Metering pump
7. FuelFix

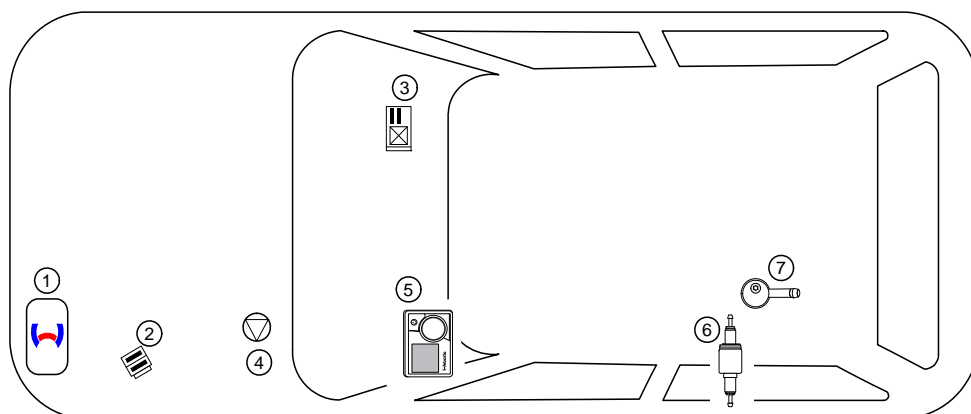

Information on Total Installation Time

The total installation time includes the time needed for mounting and demounting the vehicle-specific components, the heater specific installation time and all other times required for the system integration and initial start-up of the heater. The total installation time may vary for vehicle equipment other than provided.

Information on Operating and Installation Instructions

1 Important information (not complete)

1.1 Installation and repair



The improper installation or repair of Webasto heating and cooling systems can cause fire or the leakage of deadly carbon monoxide, leading to serious injury or death.



To install and repair Webasto heating and cooling systems you need to have completed a special company training course and have the appropriate technical documentation, special tools and special equipment.



Installation and repair may ONLY be carried out by persons trained and certified in a Webasto training course. NEVER try to install or repair Webasto heating or cooling systems if you have not completed a Webasto training course, you do not have the necessary technical skills and you do not have the technical documentation, tools and equipment available to ensure that you can complete the installation and repair work properly.

Only use genuine Webasto parts. See the Webasto air and water heaters accessories catalogue for this purpose.

1.2 Operation

To ensure safe operation, we recommend having the heater checked every two years by an authorised Webasto dealer, especially when used over a long period and/or under extreme environmental conditions.

Do not operate the heater in closed rooms due to the danger of poisoning and suffocation.

Always switch off the heater before refuelling.

The heater may only be used with the prescribed fuel diesel (DIN EN 590) or petrol (DIN EN 228).

The heater may not be cleaned with a high-pressure cleaner.

1.3 Please note

ALWAYS follow all Webasto installation and operating instructions and observe all warnings.

To become familiar with and understand all functions and properties of the heater, the operating instructions must be read carefully and observed at all times.

For proper, safe installation and repair work, the installation instructions with all warnings and safety information must be carefully read and observed at all times. Please always contact a workshop authorised by Webasto for all installation and repair work.

Important

Webasto shall assume no liability for defects, damage and injuries resulting from a failure to observe the installation, repair and operating instructions of the information contained in them.

This liability exclusion particularly applies to improper installations and repairs, installations and repairs by untrained persons or in the case of a failure to use genuine spare parts.

The liability due to culpable disregard to life, limb or health and due to damage or injuries caused by a wilful or reckless breach of duty remain unaffected, as does the obligatory product liability.

Installation should be carried out according to the general, standard rules of technology. Unless specified otherwise, fasten hoses, lines and wiring harnesses to original vehicle lines and wiring harnesses using cable ties. Insulate loose wire ends and tie back. Connectors on electronic components have to audibly click into place during installation.

Sharp edges should be fitted with rub protection. Spray unfinished body areas, e.g. drilled holes, with anti-corrosion wax (Tectyl 100K).

Observe the instructions and guidelines of the respective vehicle manufacturer for demounting and mounting vehicle specific components!

The initial startup is to be executed with the Webasto Thermo Test Diagnosis.

When installing a programmable control module (e.g. a PWM Gateway), the corresponding settings must be checked or adjusted.

2 Statutory regulations governing installation

Guidelines	Thermo Top Evo
Heating Directive ECE R122	E1 00 0258
EMC Directive ECE R10	E1 04 5627

Note

The regulations of these guidelines are binding in the scope of the Directive 70/156/EEC and/or 2007/46/EC (for new vehicle models from 29/04/2009) and should also be observed in countries in which there are no special regulations.

Important

Failure to follow the installation instructions will result in the invalidation of the type approval for the heater and therefore invalidation of the general **homologation of the vehicle**.

Note

The heater is licensed in accordance with paragraph 19, section 3, No. 2b of the StVZO (German Road Traffic Licensing Authority).

2.1 Excerpt from ECE regulation 122 (heating system) paragraph 5 for the installation of the heater

Beginning of excerpt.

ANNEX VII

REQUIREMENTS FOR COMBUSTION HEATERS AND THEIR INSTALLATION

1. GENERAL REQUIREMENTS

1.7.1. A clearly visible tell-tale in the operator's field of view shall inform when the combustion heater is switched on or off.

2. VEHICLE INSTALLATION REQUIREMENTS

2.1. Scope

2.1.1. Subject to paragraph 2.1.2, combustion heaters shall be installed according to the requirements of this Annex.

2.1.2. Vehicles of category O having liquid fuel heaters are deemed to comply with the requirements of this Annex.

2.2. Positioning of heater

2.2.1. Body sections and any other components in the vicinity of the heater must be protected from excessive heat and the possibility of fuel or oil contamination.

2.2.2. The combustion heater shall not constitute a risk of fire, even in the case of overheating. This requirement shall be deemed to be fulfilled if the installation ensures an adequate distance to all parts and suitable ventilation, by the use of fire resistant materials or by the use of heat shields.

2.2.3. In the case of M2 and M3 vehicles, the heater must not be positioned in the passenger compartment. However, an installation in an effectively sealed envelope which also complies with the conditions in paragraph 2.2.2 may be used.

2.2.4. The label referred to in paragraph 1.4 or a duplicate, must be positioned so that it can be easily read when the heater is installed in the vehicle.

2.2.5. Every reasonable precaution should be taken in positioning the heater to minimise the risk of injury and damage to personal property.

2.3. Fuel supply

2.3.1. The fuel filler must not be situated in the passenger compartment and must be provided with an effective cap to prevent fuel spillage.

2.3.2. In the case of liquid fuel heaters, where a supply separate to that of the vehicle is provided, the type of fuel and its filler point must be clearly labelled.

2.3.3. A notice, indicating that the heater must be shut down before refuelling, must be affixed to the fuelling point. In addition a suitable instruction must be included in the manufacturer's operating manual.

2.4. Exhaust system

2.4.1. The exhaust outlet must be located so as to prevent emissions from entering the vehicle through ventilators, heated air inlets or opening windows.

2.5. Combustion air inlet

2.5.1. The air for the combustion chamber of the heater must not be drawn from the passenger compartment of the vehicle.

2.5.2. The air inlet must be so positioned or guarded that blocking by rubbish or luggage is unlikely.

2.6. Heating air inlet

2.6.1. The heating air supply may be fresh or recirculated air and must be drawn from a clean area not likely to be contaminated by exhaust fumes emitted either by the propulsion engine, the combustion heater or any other vehicle source.

2.6.2. The inlet duct must be protected by mesh or other suitable means.

2.7. Heating air outlet

2.7.1. Any ducting used to route the hot air through the vehicle must be so positioned or protected that no injury or damage could be caused if it were to be touched.

2.7.2. The air outlet must be so positioned or guarded that blocking by rubbish or luggage is unlikely.

End of excerpt.

In multilingual versions the German language is binding.

Hyundai Santa Fe / Grand Santa Fe

Information on Validity

This installation documentation applies to Hyundai Santa Fe / Grand Santa Fe Diesel vehicles - for validity, see page 1 - from model year 2013 and later, assuming technical modifications to the vehicle do not affect installation, any liability claims excluded. Depending on the vehicle version and equipment, modifications may be necessary during installation with respect to this 'installation documentation'.

Vehicle and engine types, equipment variants and other specifications not listed in this installation documentation have not been tested. However, installation according to this installation documentation may be possible.

Technical Information

Special Tools

- Hose clamp pliers for auto-tightening hose clamps
- Hose clamp pliers for Clic hose clamps of type W
- Automatic wire stripper 0.2 - 6mm²
- Crimping pliers for cable lug / tab connector 0.5 - 6mm²
- Torque wrench for 2.0 - 10 Nm
- Hose clamping pliers
- Metric thread-setter kit
- Deep-hole marker
- Webasto Thermo Test Diagnosis with current software

Dimensions

- All dimensions are in mm.

Tightening torque values

- Tightening torque values of 5x13 heater bolts and 5x11 heater stud bolts = 8Nm.
- Tightening torque value of 5x15 water connection piece retaining plate bolt = 7Nm.
- Tighten other bolt connections in accordance with manufacturer's instructions or in accordance with state-of-the-art technology.

Explanatory Notes on Document

You will find an identification mark on the outside top right corner of the page in question to provide you with a quick overview of the individual working steps.

Special features are highlighted using the following symbols:

Mechanical System



Electrical System



Coolant Circuit



Combustion Air



Fuel



Exhaust Gas



Software



Specific risk of damage to components.



Specific risk due to electrical voltage.



Specific risk of injury or fatal accidents.



Specific risk of fire or explosion.



Reference to the manufacturer's vehicle-specific documents or to the general installation instructions of Webasto components.



Reference to a special technical feature.



The arrow in the vehicle icon indicates the position on the vehicle and the viewing angle.



Tightening torque according to the manufacturer's vehicle-specific documents.



Preliminary Work

Vehicle



- Open the fuel tank cap.
- Ventilate the fuel tank.
- Close the fuel tank cap again.
- Depressurise the cooling system.
- Disconnect and completely remove the battery together with the carrier.
- Remove the air filter completely, together with the intake hose.
- Remove the bumper trim.
- Remove the lower engine cover.
- Remove the left underride protection.
- Loosen the screw fittings of the left rear bench seat (2x front, 3x back), loosen the Bowden cable bracket for the seat adjustment, fold down the backrest, remove the rear bench seat.
- Open the left tank-fitting service lid.
- Remove the front passenger's side footwell trim, remove the cover underneath the glove box.
- Remove the lateral instrument panel on the driver's side.
- Remove the lower instrument panel trim on the driver's side.
- Loosen the central electrical box in the passenger compartment on the left.
- Remove the knee airbag on the driver's side.
- Remove the centre console trim on the left and the right in the footwell.



Heater

- Remove years that do not apply from the type and duplicate label.
- Attach the duplicate label (type label) visibly in the appropriate place in the engine compartment.



Heater Installation Location

- 1 Heater

Installation location

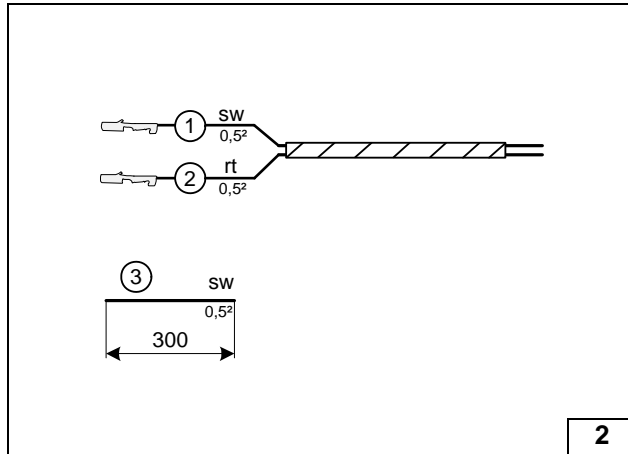
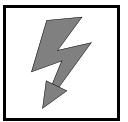

Preparing Electrical System

Wire sections retain their numbering in the entire document.

Produce all following electrical connections as shown in the wiring diagram.

- ① Black (sw) wire of fan controller wiring harness
- ② Red (rt) wire of fan controller wiring harness

Cutting wires to length

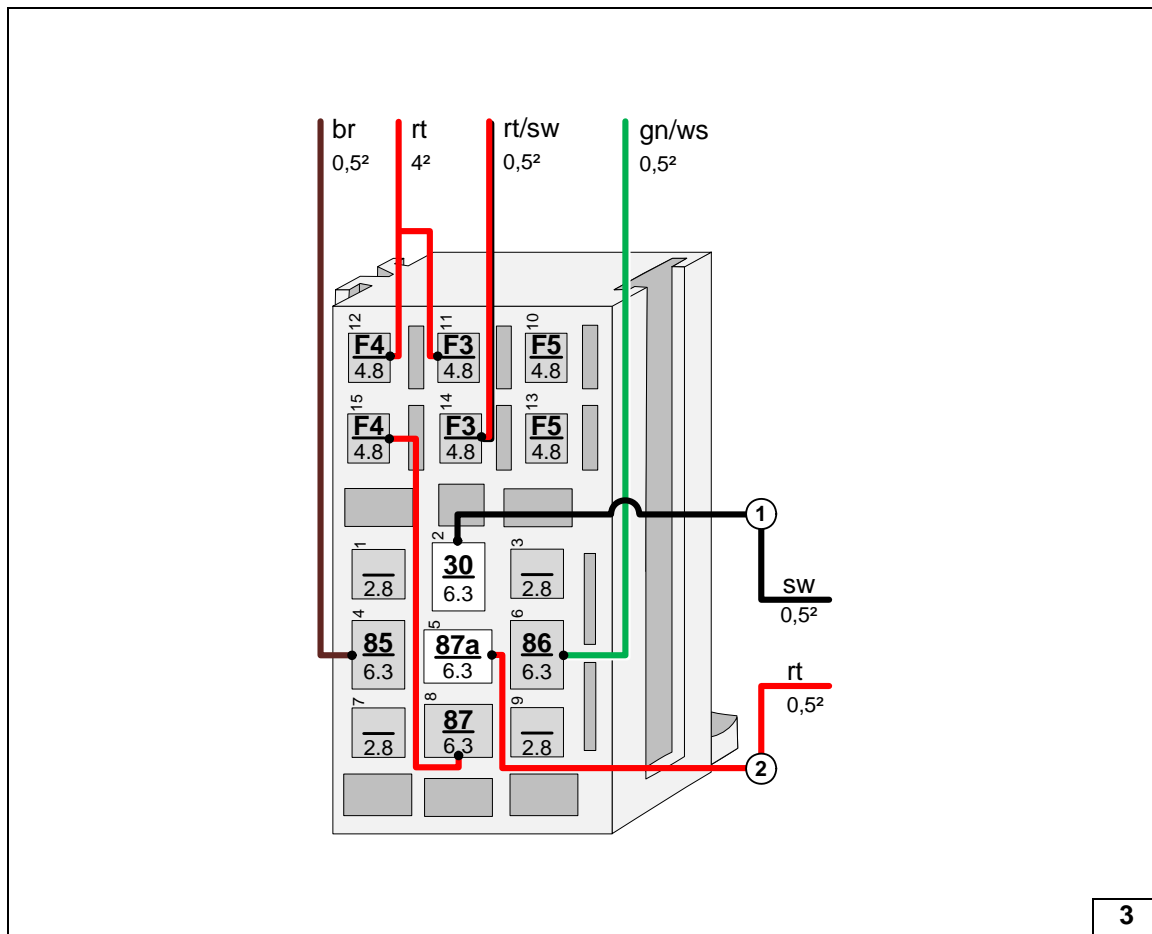

Connecting wires to passenger compartment relay and fuse holder

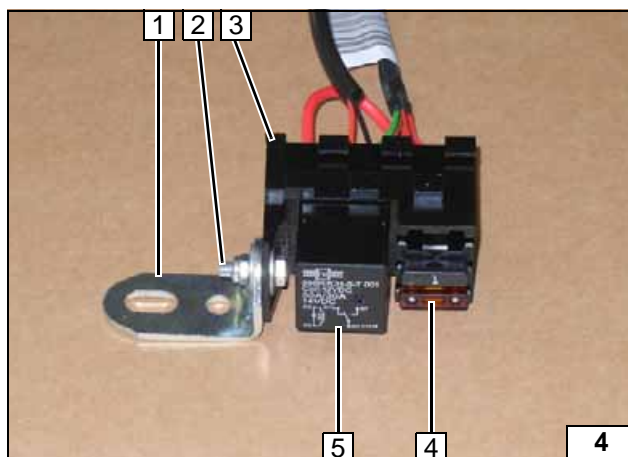

- 1 Angle bracket
- 2 M5x16 bolt, large diameter washer [2x], nut
- 3 Passenger compartment relay and fuse holder
- 4 7.5A fuse F4
- 5 Relay K1

Premounting relay and fuse holder

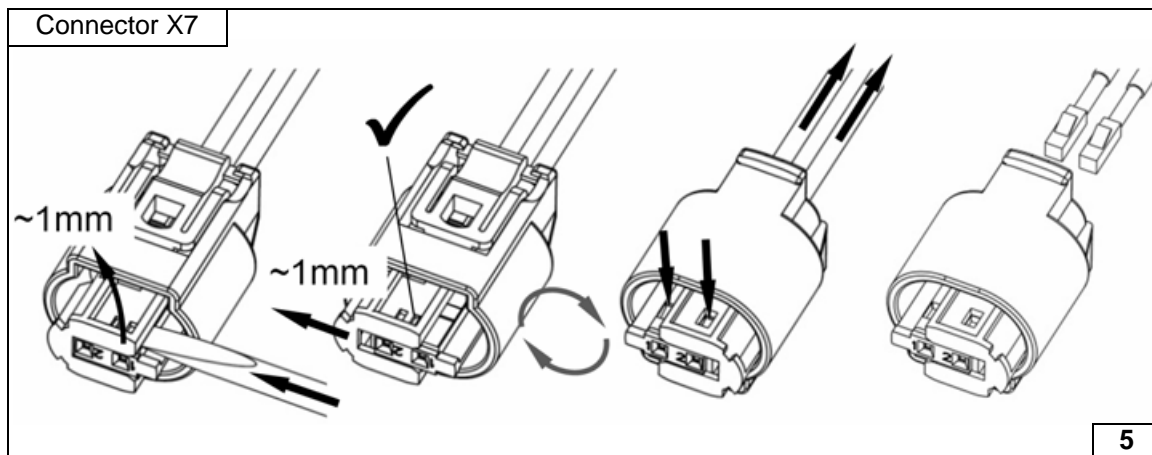
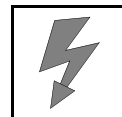

Dismantling metering pump connector

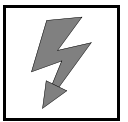

Electrical System



Wiring harness pass through

- 1 Protective rubber plug
- 2 Heater wiring harnesses, heater control

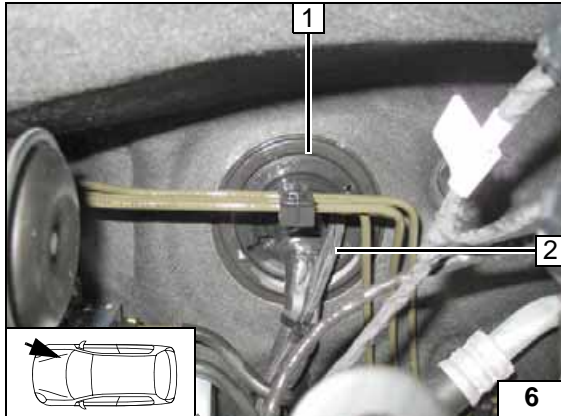

Passenger compartment relay and fuse holder

- 1 Original vehicle bolt, angle bracket

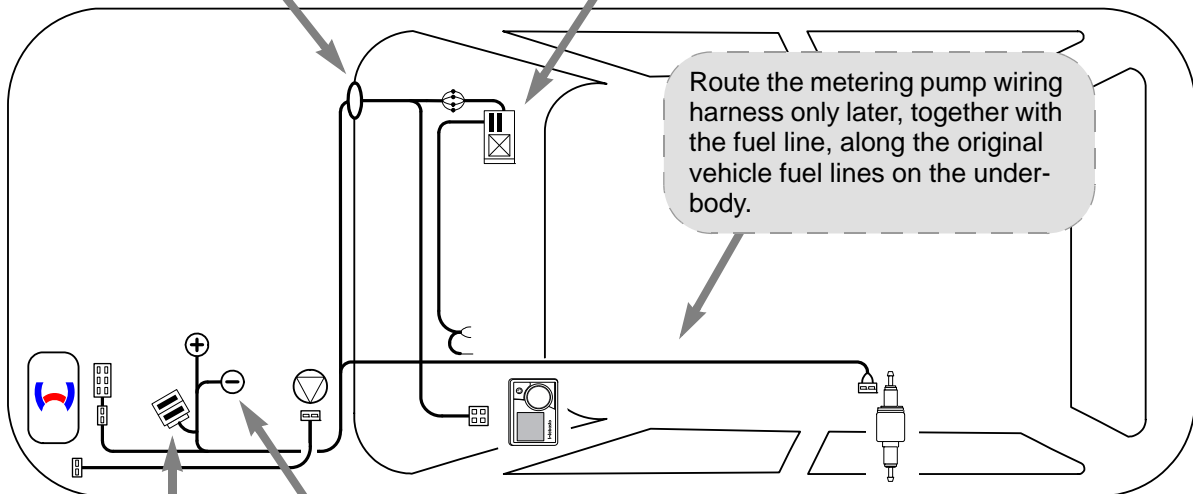
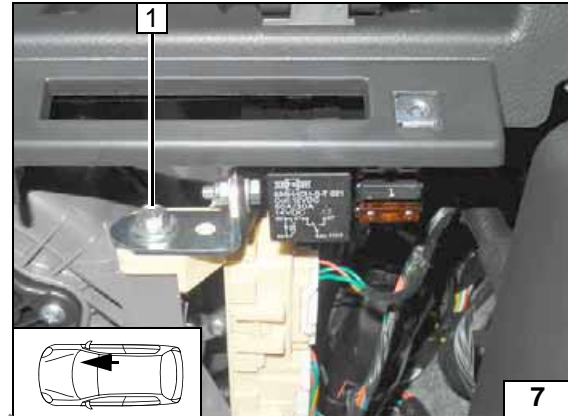

Wiring harness routing diagram

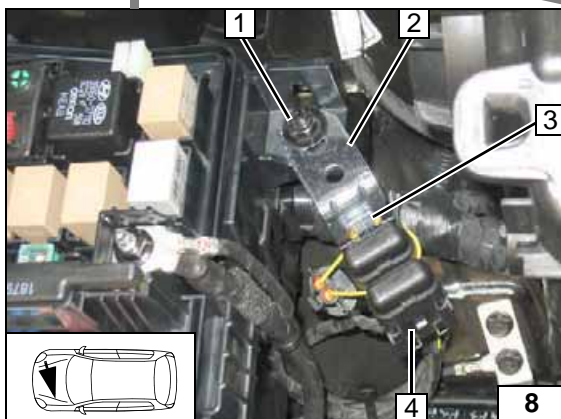

Engine compartment fuse holder

- 1 Original vehicle nut
- 2 Angle bracket
- 3 M5x16 bolt, washer [2x], retaining plate of fuse holder, nut
- 4 Fuses F1-2

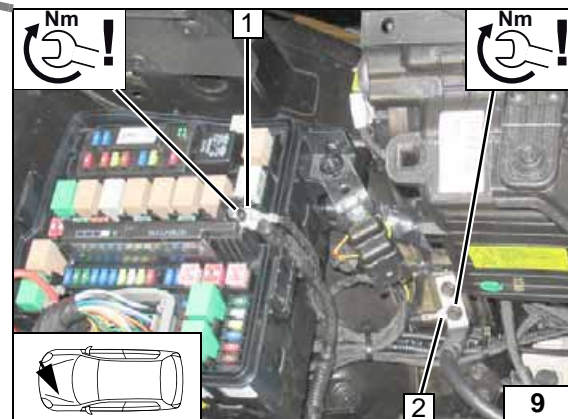

Positive and earth wire

- 1 Positive wire on original vehicle positive support point
- 2 Earth wire on original vehicle earth support point





Fan Controller

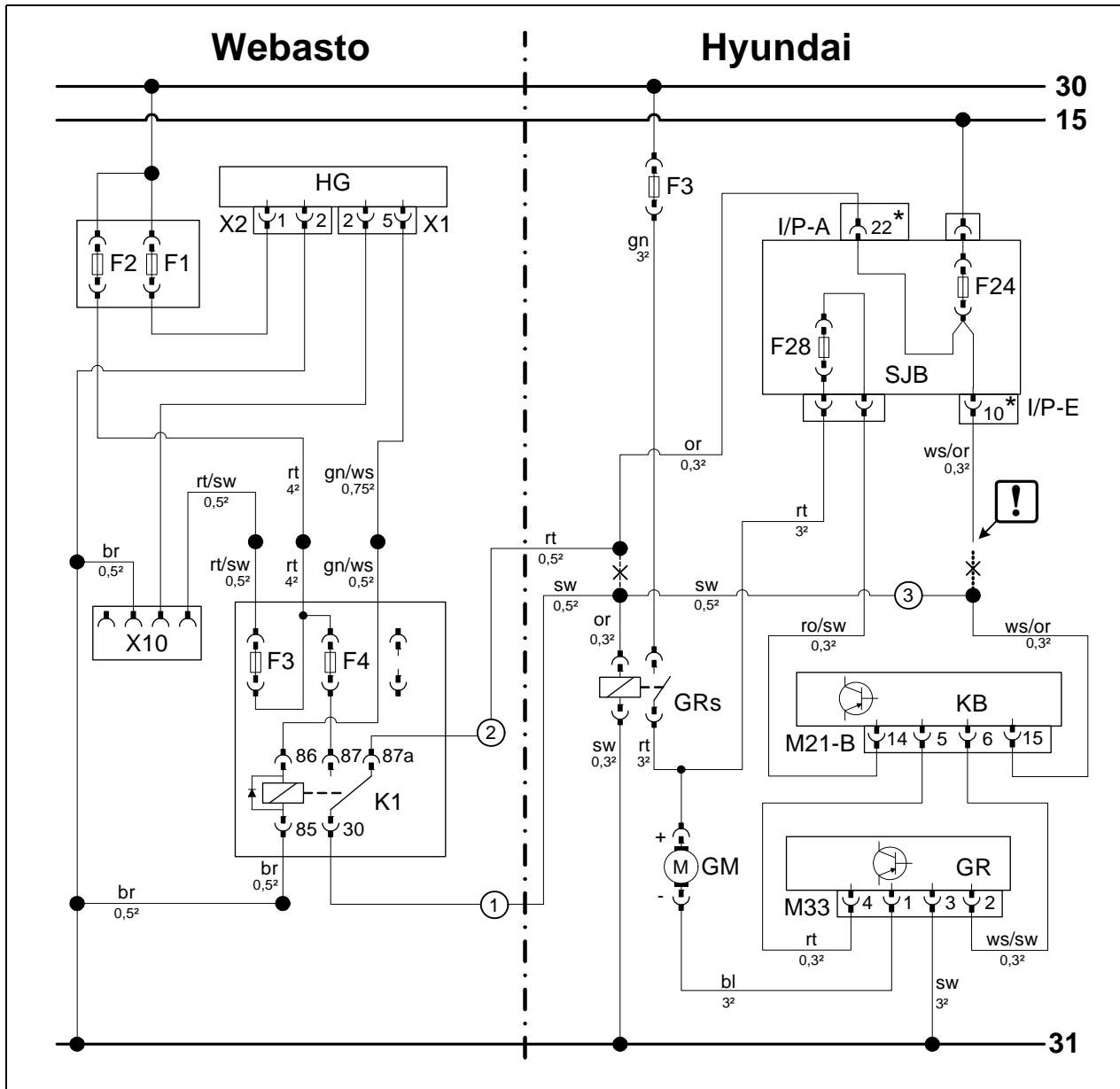

Wiring diagram

Webasto components		Vehicle components		Colours and symbols	
HG	TT-Evo heater	F3	40A fuse	rt	red
X1	6-pin heater connector	SJB	Central electrical box	sw	black
X2	2-pin heater connector	F24	7.5A fuse	or	orange
F1	20A fuse	F28	7.5A fuse	gn	green
F2	30A fuse	I/P-A	Connector SJB	ro	pink
X10	4-pin connector of heater control	I/P-E	Connector SJB	ws	white
F3	1A fuse	GRs	Fan relay	br	brown
F4	7.5A fuse	KB	A/C control panel	bl	blue
K1	Fan relay	M21-B	Connector of KB		
		GM	Fan motor		
		GR	Fan controller	*	Numbering of PIN may vary
		M33	Connector GR	!	Insulate wire end and tie back
				X	Cutting point
					Wiring colours may vary.

Legend

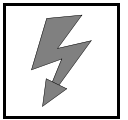

- 1 Passenger compartment relay and fuse holder wiring harness
- 2 Heater wiring harness

Connecting same colour wires of wiring harnesses

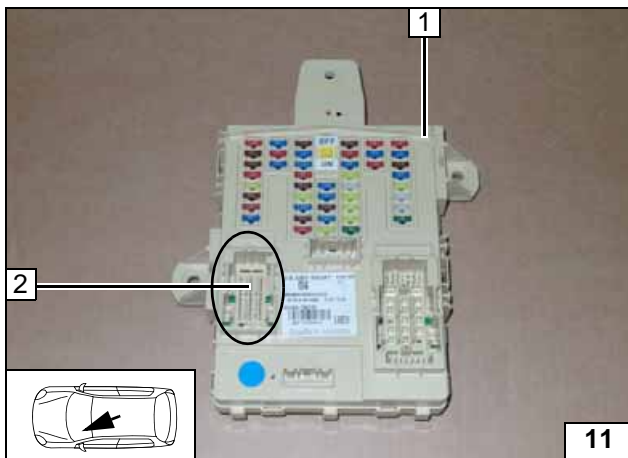

Central electrical box removed for demonstration purposes!



- 1 Central electrical box SJB
- 2 Socket of 31 pin connector I/P-A

Front view of central electrical box SJB

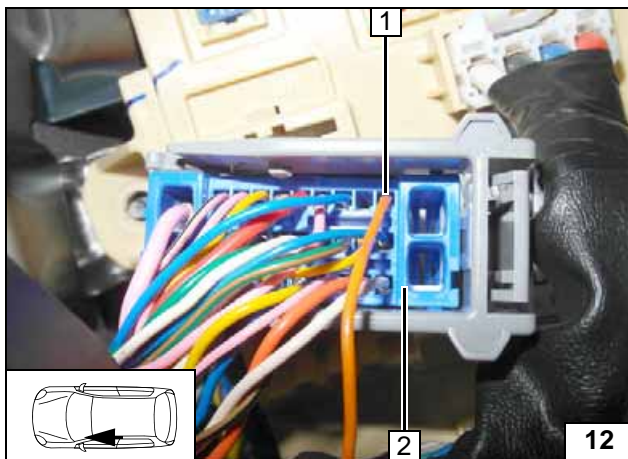

- 1 Orange (or) wire pin 22 (numbering may vary)
- 2 31-pin connector I/P-A

View of connector I/P-A

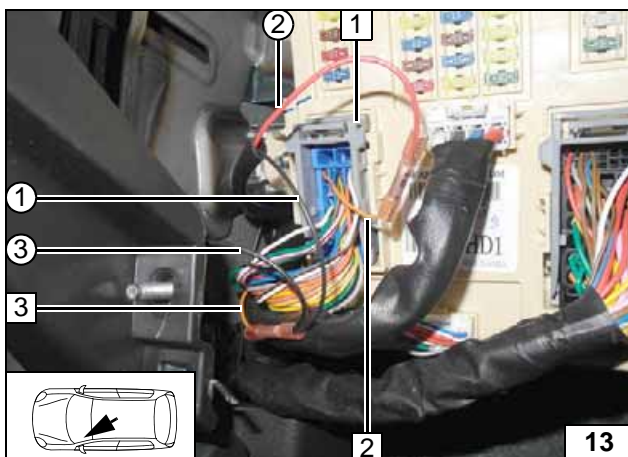

- 1 31-pin connector I/P-A
- 2 Orange (or) wire of 31-pin connector pin 22
- 3 Orange (or) wire of original vehicle fan relay
- ① Black (sw) wire of K1/30 from fan controller wiring harness
- ② Red (rt) wire of K1/87a from fan controller wiring harness
- ③ Black (sw) wire of K1/30 to connector I/P-E

Connection to central electrical box SJB

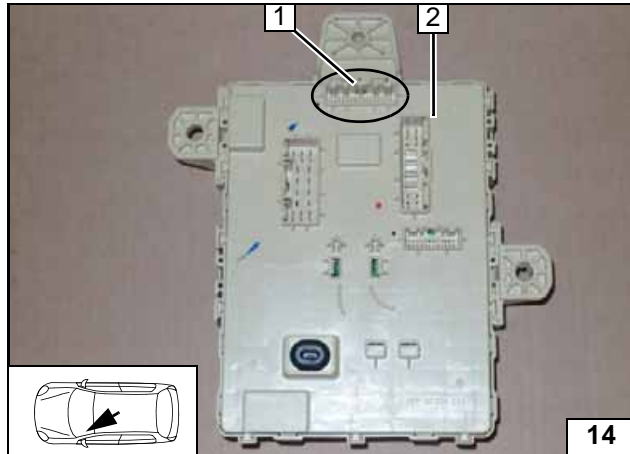
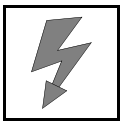

Central electrical box removed for demonstration purposes!



- 1 Socket of 32 pin connector I/P-E
- 2 Central electrical box SJB

Rear view of central electrical box SJB

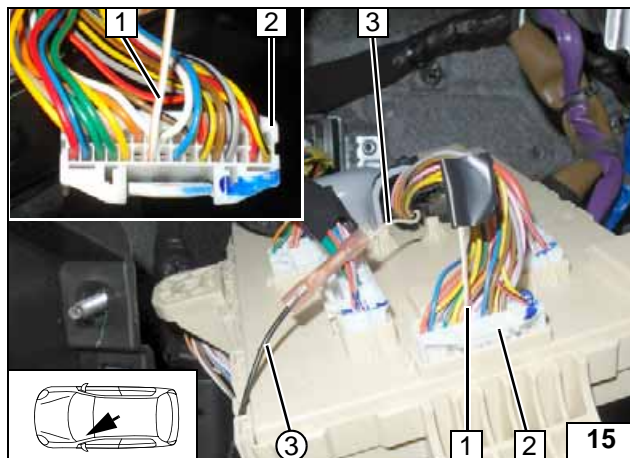

- 1 Insulate and tie back white/orange (ws/or) wire of 32 pin connector I/P-E, pin 10 (numbering may vary)
- 2 32 pin connector I/P-E of central electrical box
- 3 White/orange (ws/or) wire of A/C control unit, pin 15
- ③ Black (sw) wire from K1/30

Connecting A/C control panel

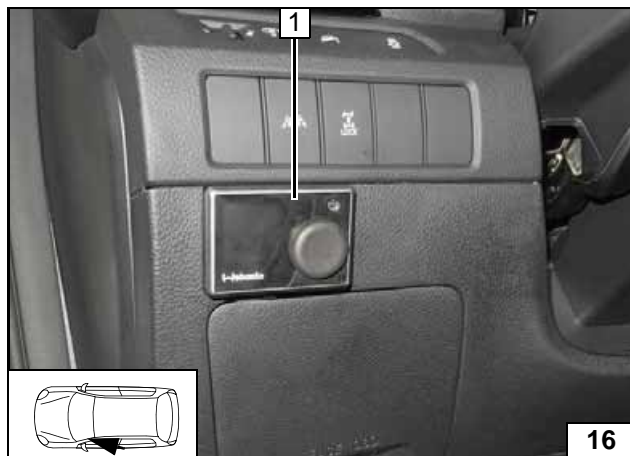

MultiControl CAR Option

- 1 MultiControl CAR



Installing MultiControl CAR

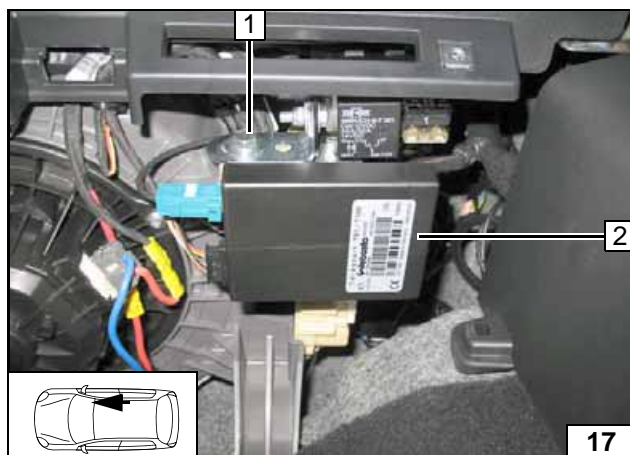

Remote Option (Telestart)

Angle bracket of receiver 1 down by 90° and fasten on original vehicle bolt.

- 2 Receiver



Installing receiver

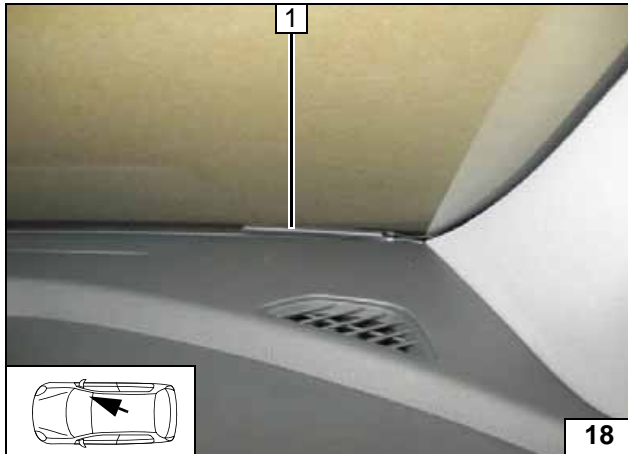

1 Aerial

Installing aerial

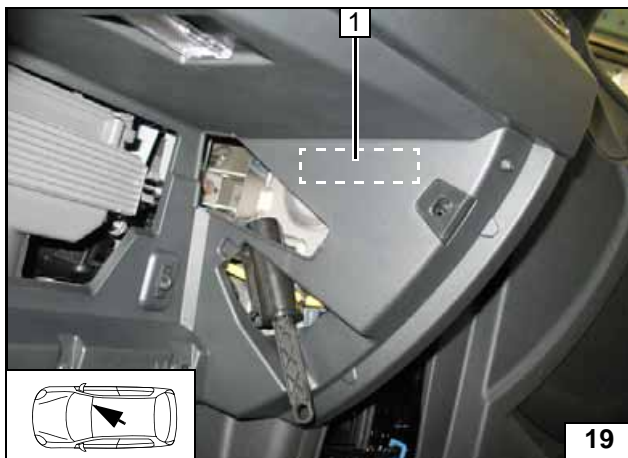

Temperature sensor T100 HTM

Fasten temperature sensor 1 with double-sided adhesive tape (hidden).



Installing temperature sensor

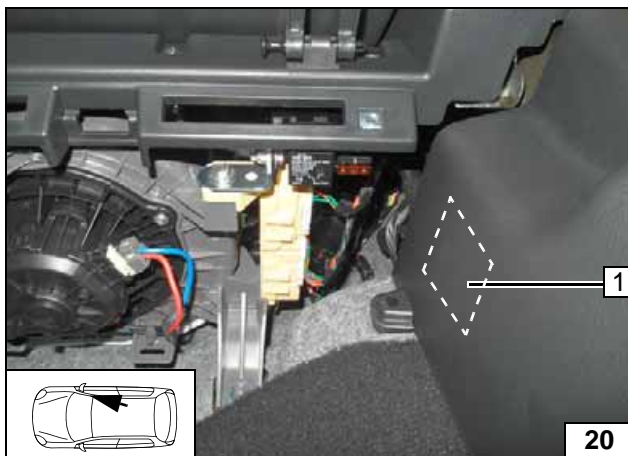

Thermo Call Option

1 Receiver (fasten from the inside with double-sided adhesive tape)



Installing receiver

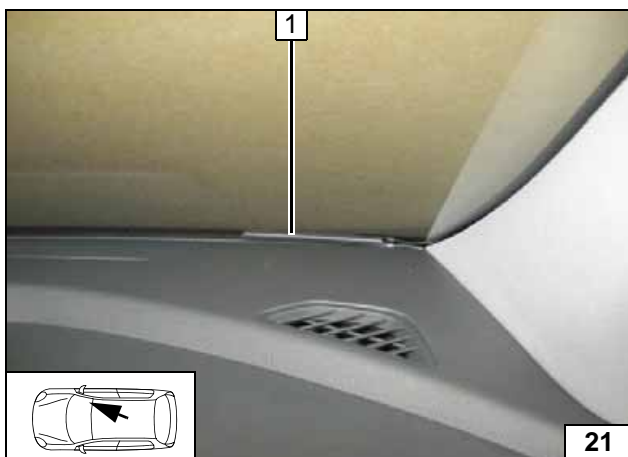

1 Aerial (optional)

Installing aerial

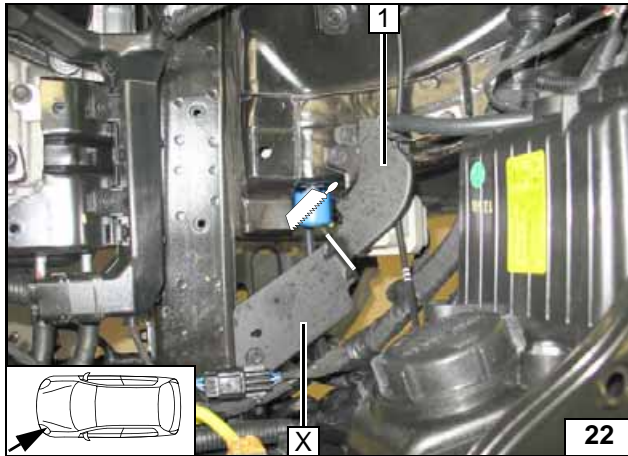
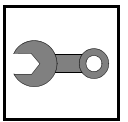

Preparing Installation Location

1 Original vehicle plate

X =

Cutting off plate

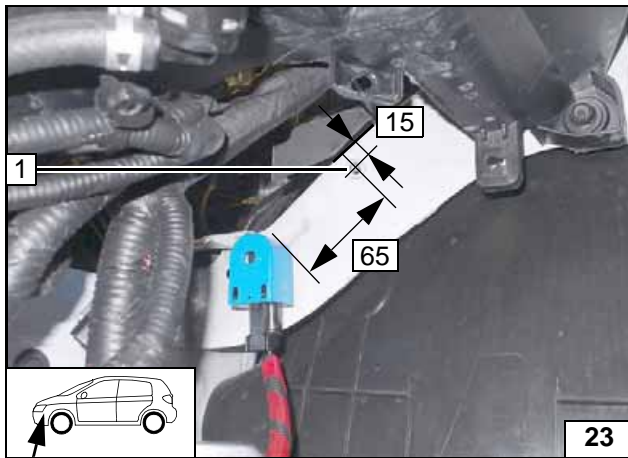

1 9.1mm dia. hole; rivet nut

Moving original vehicle relay (if present)

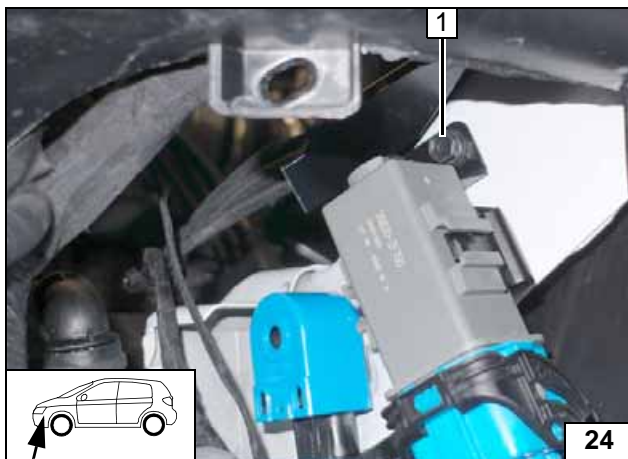

1 Original vehicle bolt

Moving original vehicle relay (if present)

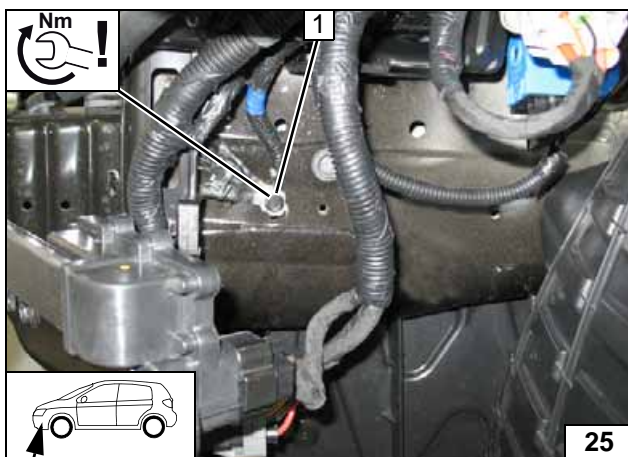

1 Earth support point on existing threaded hole



Relocating earth support point

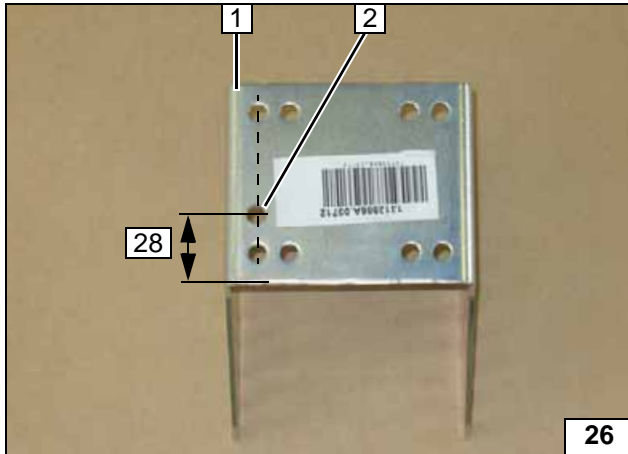
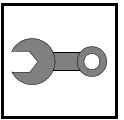

- 1 Bracket
- 2 7 mm dia. hole

Preparing bracket

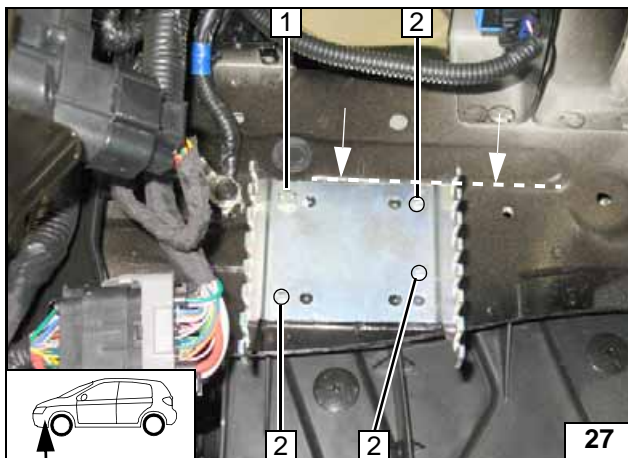

Loosely mount bracket and align with beading of frame side member.

- 1 M6x20 bolt, existing threaded hole
- 2 Copy hole pattern, 9.1 mm dia. hole [3x]

Copying hole pattern

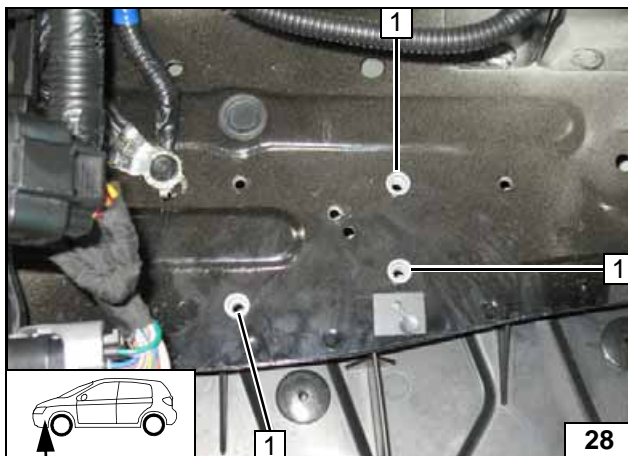

Remove bracket.

- 1 9.1 mm dia. hole; rivet nut [3x]

Installing rivet nut

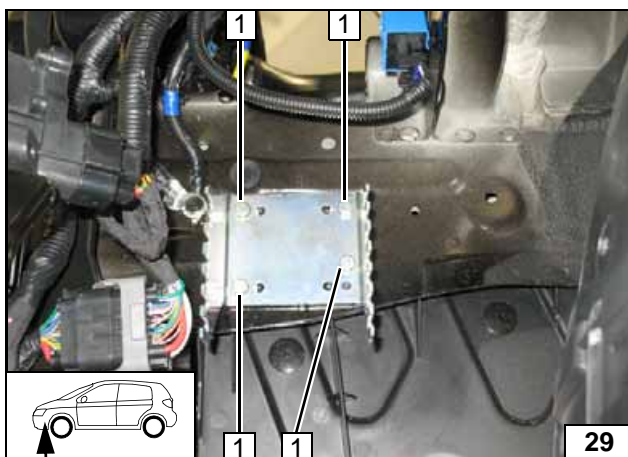

Insert large diameter washers between bracket and body.

- 1 M6x20 bolt, large diameter washer, spring lockwasher [4x each]

Installing bracket

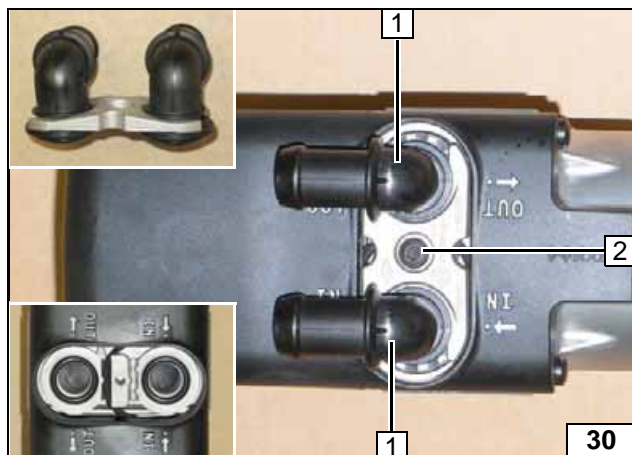

Preparing Heater

- 1 Water connection piece, sealing ring [2x each]
- 2 5x15 self-tapping bolt, retaining plate of water connection piece



Installing water connection piece

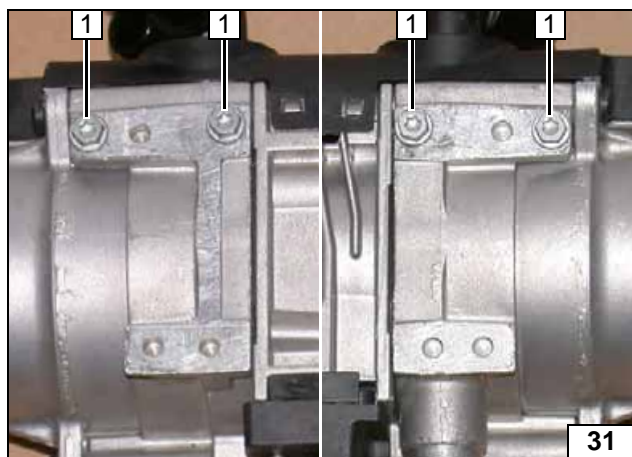

Screw 5x13 self-tapping bolts 1 [4x] into existing holes by a maximum of 3 thread turns.



Premounting bolts loosely

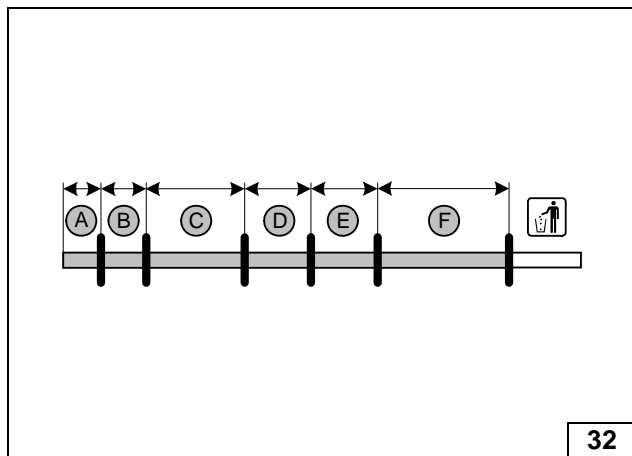

2.0 D / 2.2 D only front heat exchanger and SG

- A = 60
- B = 90
- C = 790
- D = 140
- E = 160
- F = 830



Cutting hoses to length

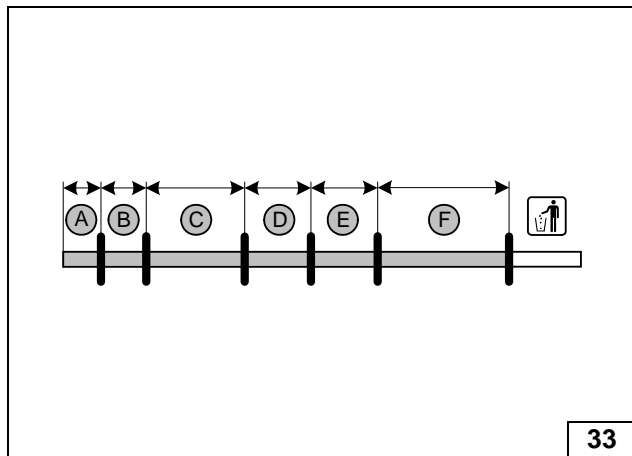

2.2 D only front heat exchanger and AG

- A = 60
- B = 90
- C = 750
- D = 140
- E = 160
- F = 830



Cutting hoses to length

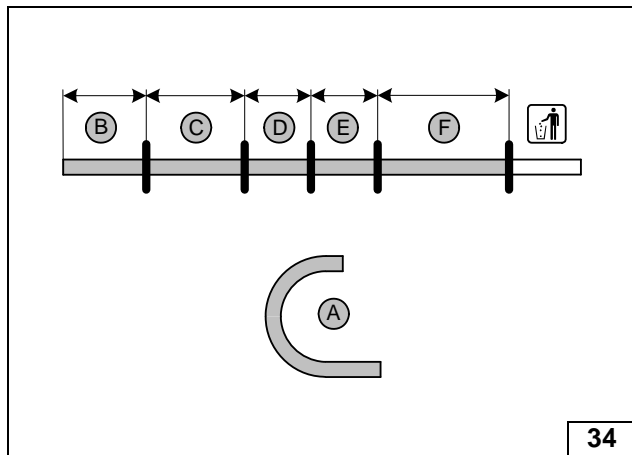

2.2 D with front / rear heat exchanger and AG

Hose A = 180°, 20mm dia. moulded hose

- B = 155
- C = 760
- D = 140
- E = 160
- F = 840



Cutting hoses to length

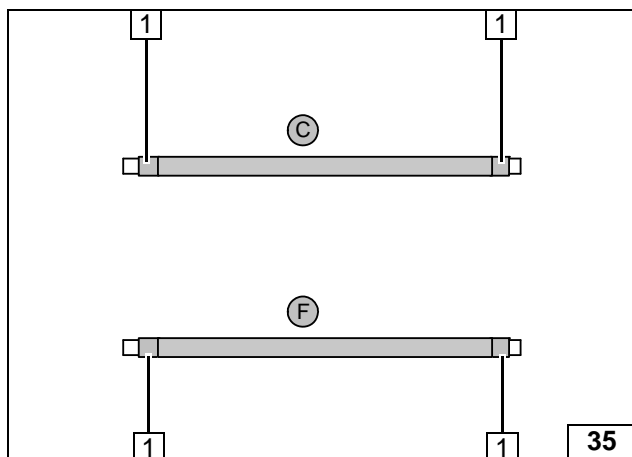

All vehicles

Push braided protection hoses onto hoses C and F and cut to length. Cut heat shrink plastic tubing to size.

- 1 50 mm long heat shrink plastic tubing [4x]



Preparing hoses

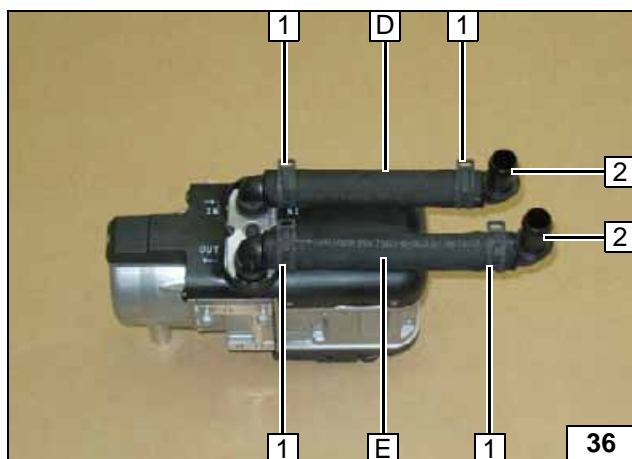

- 1 25mm dia. spring clip [4x]
- 2 18x18mm dia. 90° connecting pipe [2x]

Premounting hoses

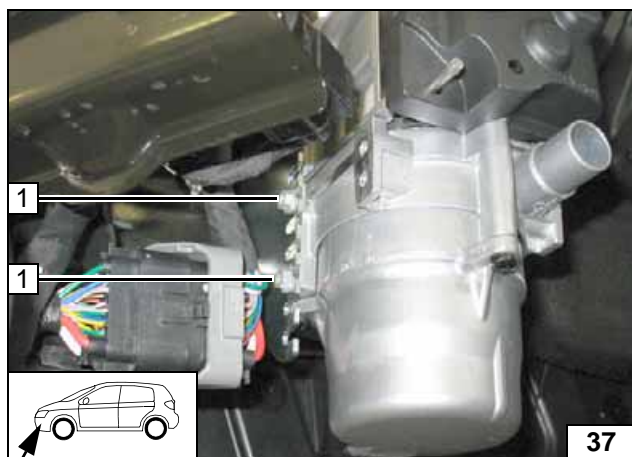

Installing Heater

- 1 Tighten 5x13 self-tapping bolt [2x]

Installing heater

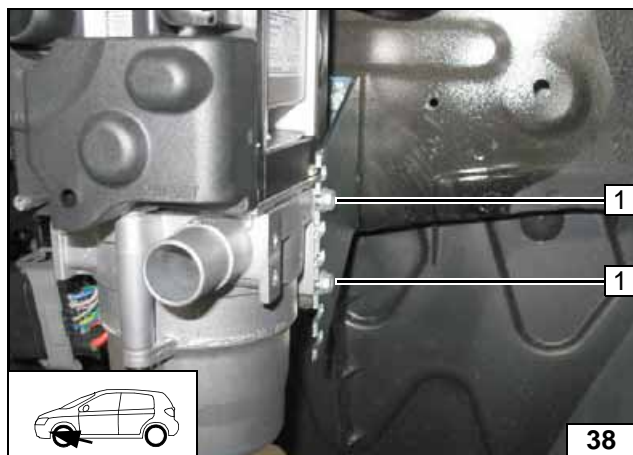
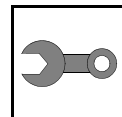

- 1 Tighten 5x13 self-tapping bolt [2x]

Installing heater

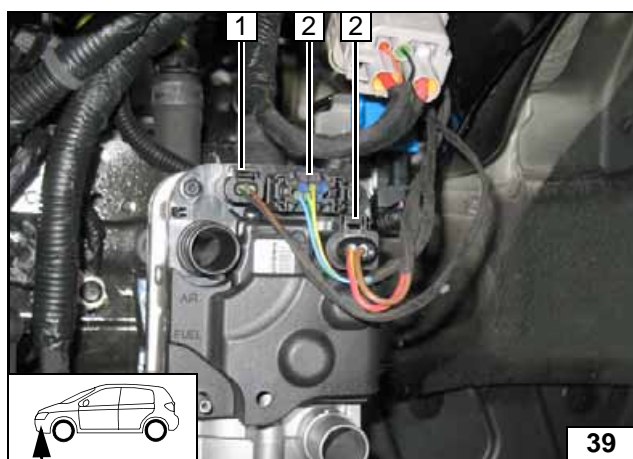

- 1 Connector of circulating pump wiring harness
- 2 Heater wiring harness connector [2x]

Installing wiring harness

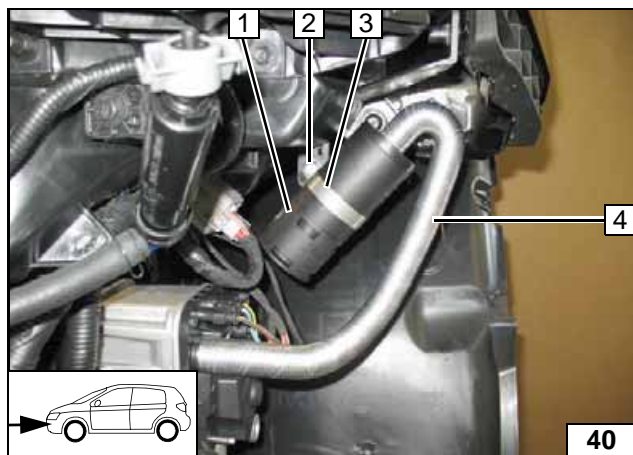
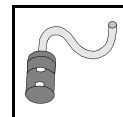

Combustion Air

- 1 Silencer
- 2 M5x16 bolt, existing hole, flanged nut
- 3 51mm dia. clamp
- 4 Combustion air pipe



**Mounting
combustion
air pipe
and silencer**

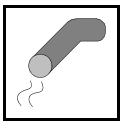

Exhaust Gas

a1 = 650
a2 = 140

X=

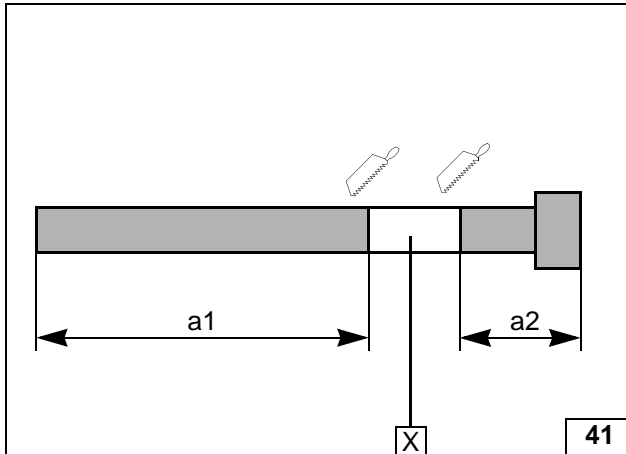

Preparing exhaust pipe

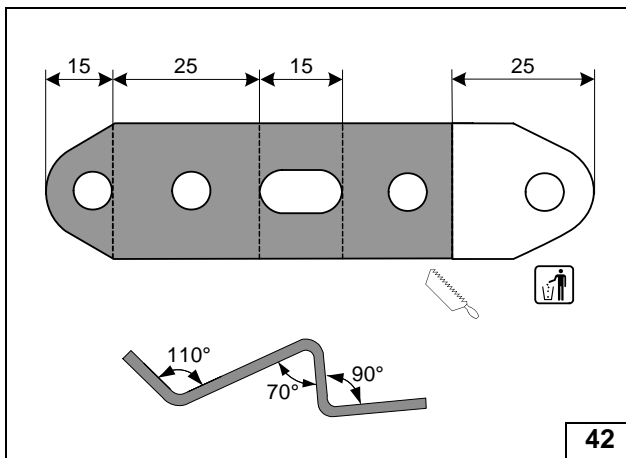

Preparing perforated bracket

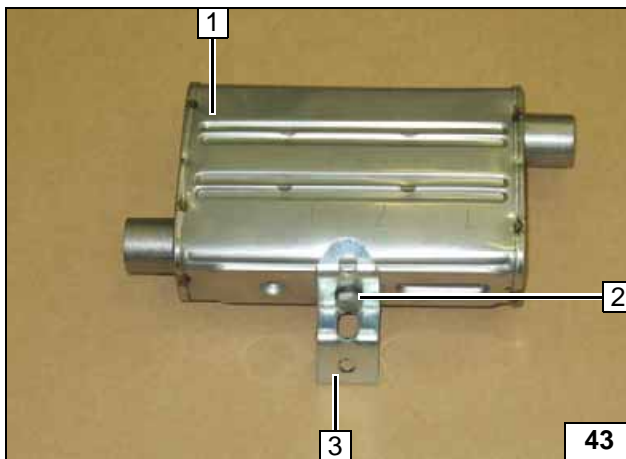

- 1 Silencer
- 2 M6x16 bolt, spring lockwasher
- 3 Perforated bracket

Premounting silencer

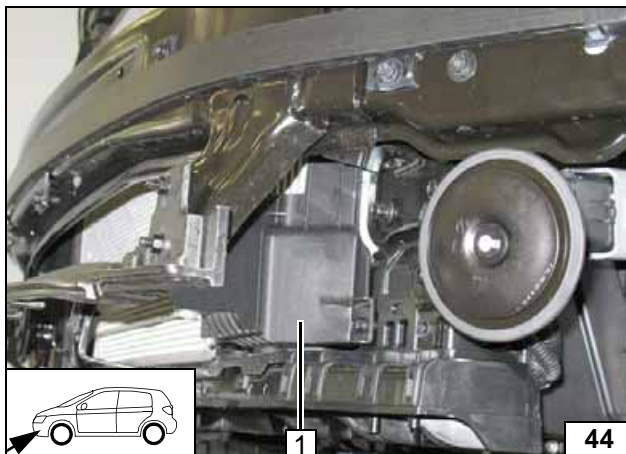

- 1 Original vehicle trim

Removing trim

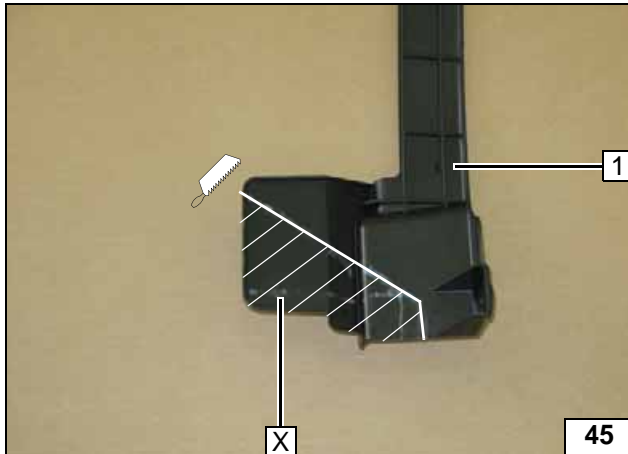
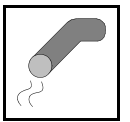

1 Original vehicle trim

X =

Cutting out trim

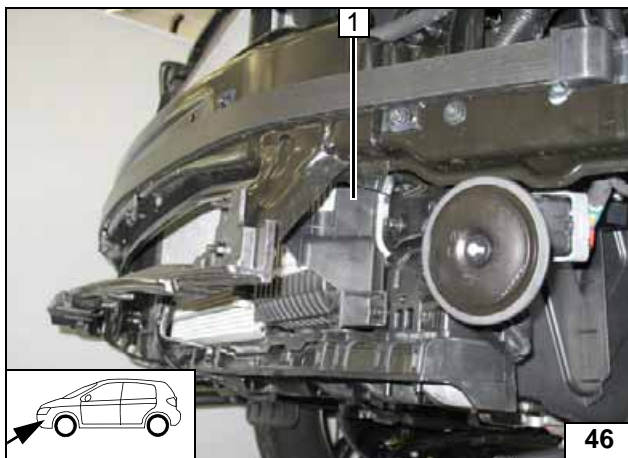

1 Original vehicle trim

Installing trim

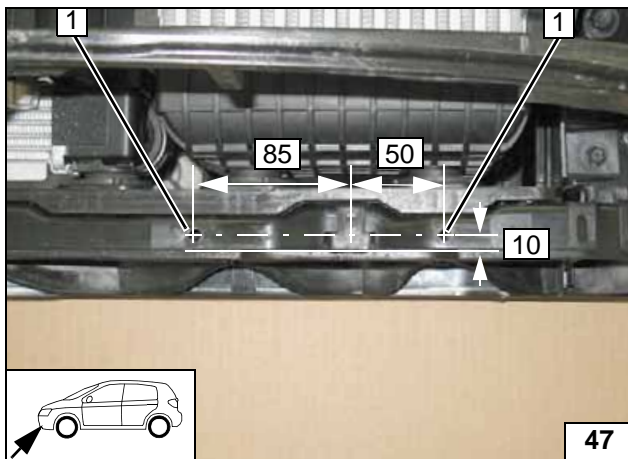

1 7 mm dia. hole [2x]

Copying hole pattern

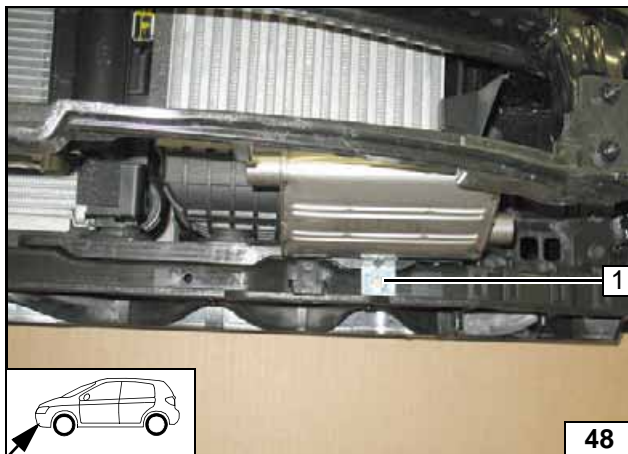

1 M6x20 bolt, flanged nut

Installing silencer

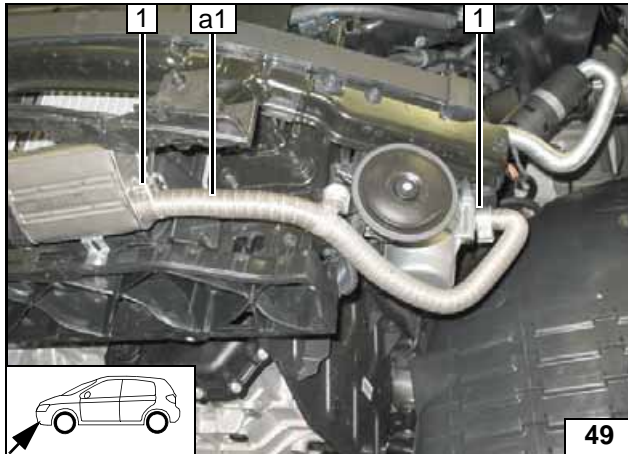
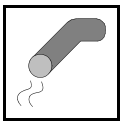

- 1 Hose clamp [2x]

Installing exhaust pipe a1

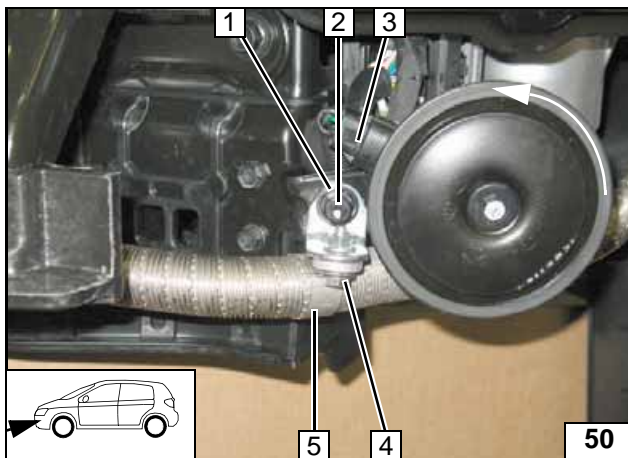

Drill out angle bracket at position 1 to 8.5mm dia. Align the horn as shown.



- 2 Original vehicle bolt
- 3 Horn connector
- 4 M6x20 bolt, 5 mm shim, angle bracket, flanged nut
- 5 P-clamp

Fastening exhaust pipe a1

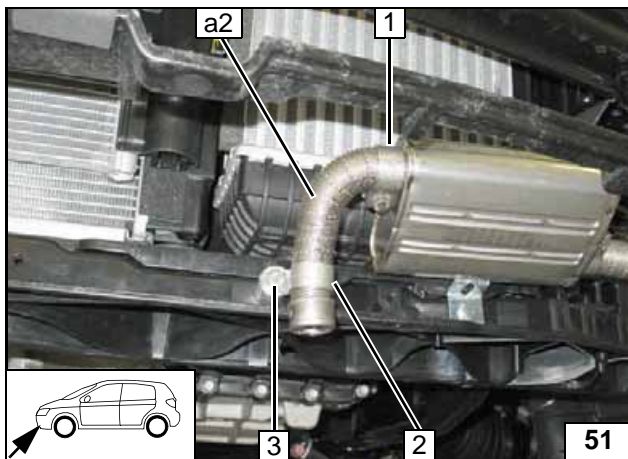

- 1 Hose clamp
- 2 P-clamp
- 3 M6x40 bolt, 5mm shim, 20mm shim, flanged nut

Installing exhaust pipe a2

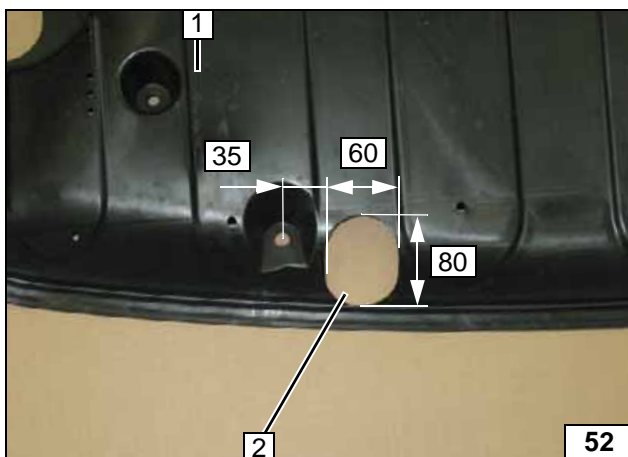

- 1 Underdrive protection
- 2 Pass through for exhaust pipe a2

Cutting out underdrive protection

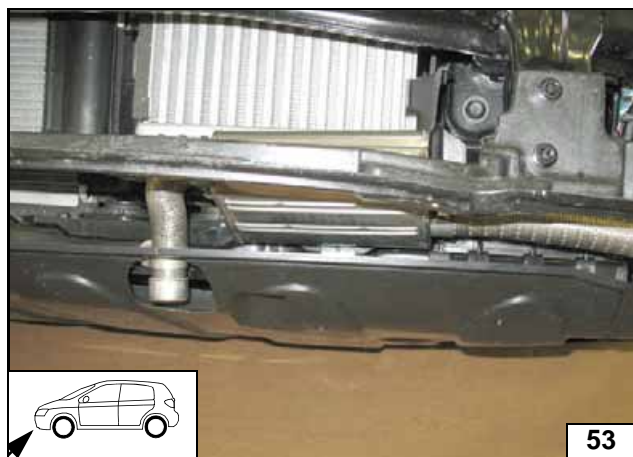
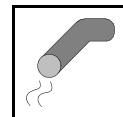

Ensure sufficient distance from neighbouring components, correct if necessary.



**Aligning
exhaust
pipe a2 and
silencer**



Coolant Circuit

2.0 D / 2.2 D Only Front Heat Exchanger and SG





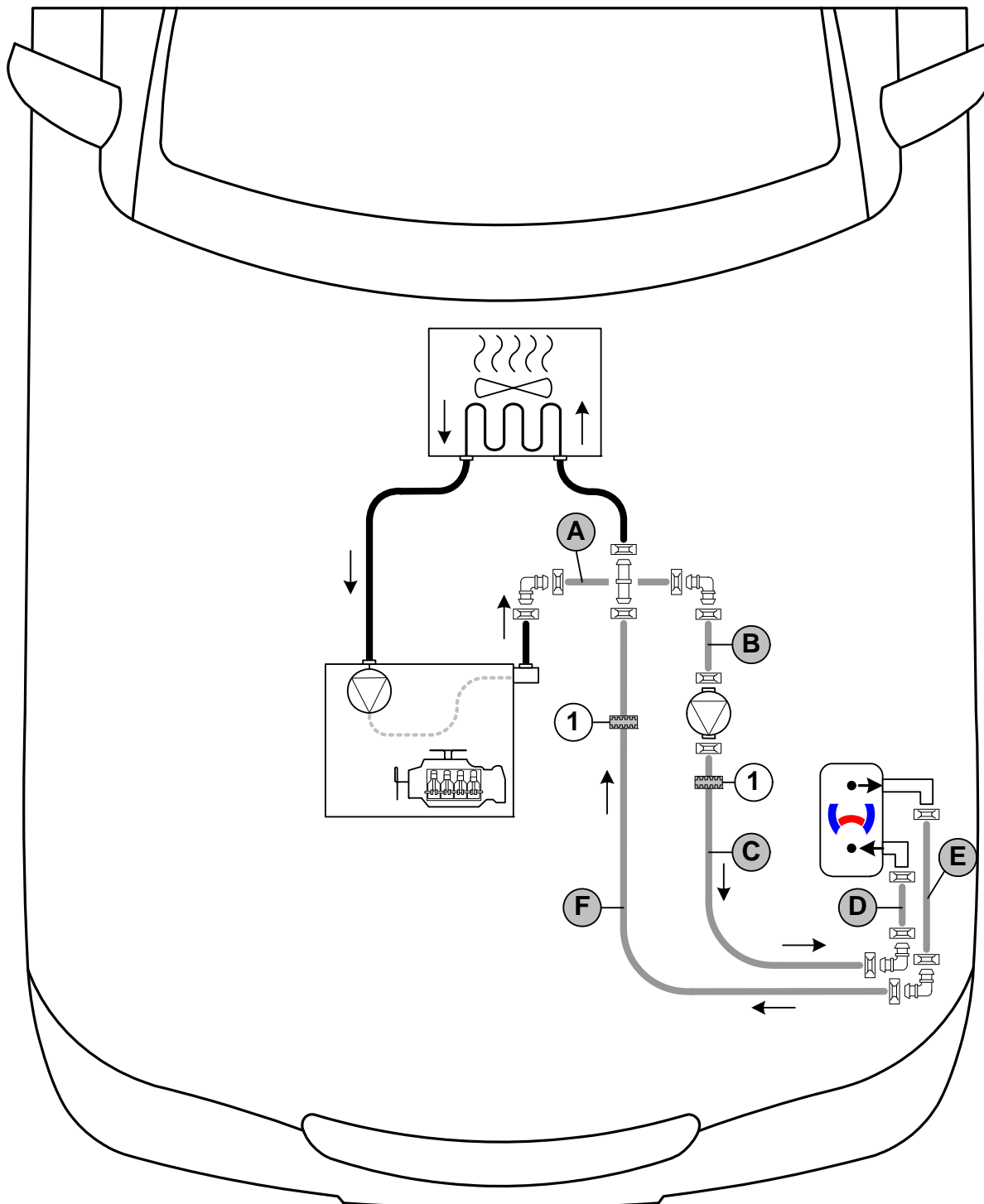

Any coolant running off should be collected in an appropriate container. Route hoses kink-free. Unless specified otherwise, always fasten using cable ties. Position clamps so that other hoses cannot be damaged. The heater must be filled with coolant when installing the hoses.

The connection should be modelled on an 'inline' circuit and based on the following diagram:



Hose routing diagram

All spring clips without a specific designation  = 25 mm dia. All connecting pipes  and  = 18x18 mm dia. 1 = Black (sw) rubber isolator .



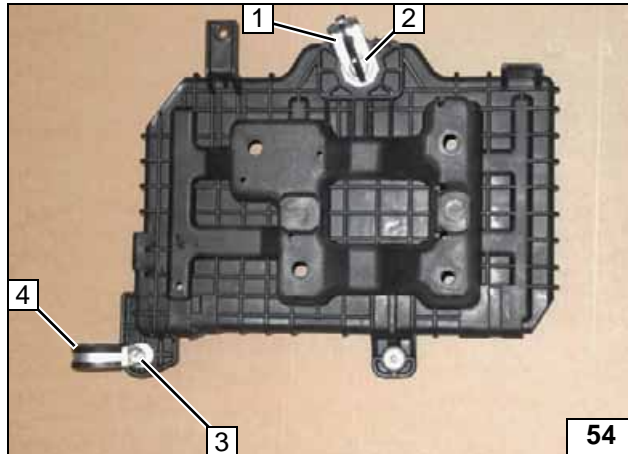

- 1 Angle bracket
- 2 M8x40 bolt, spring lockwasher, existing threaded hole
- 3 M6x50 bolt, 5mm shim, existing threaded hole
- 4 29 mm dia. rubber-coated p-clamp

Preparing battery carrier

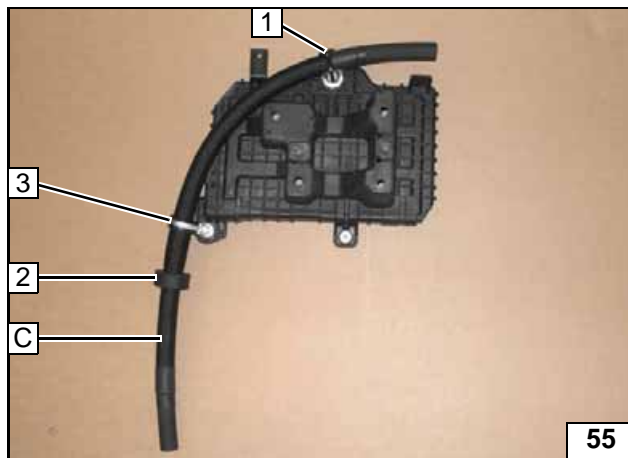

Loosely premount hose **C** below battery carrier as shown. Cable tie **1** and 29 mm dia. rubber-coated p-clamp **3** will be tightened later.



- 2 Slide on black (sw) rubber isolator

Premounting battery carrier

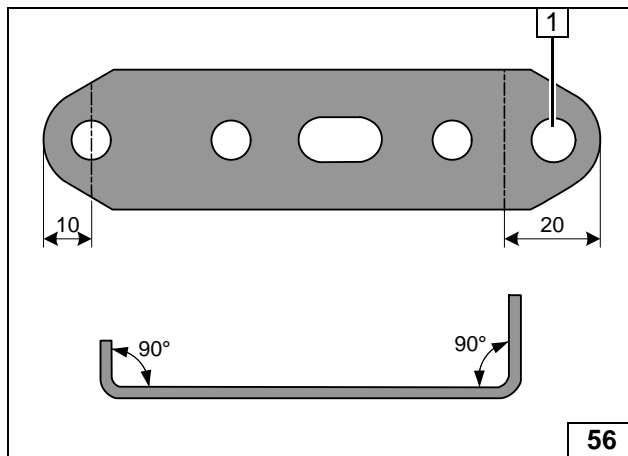

- 1 Drill out hole to 8.5 mm dia.

Preparing perforated bracket

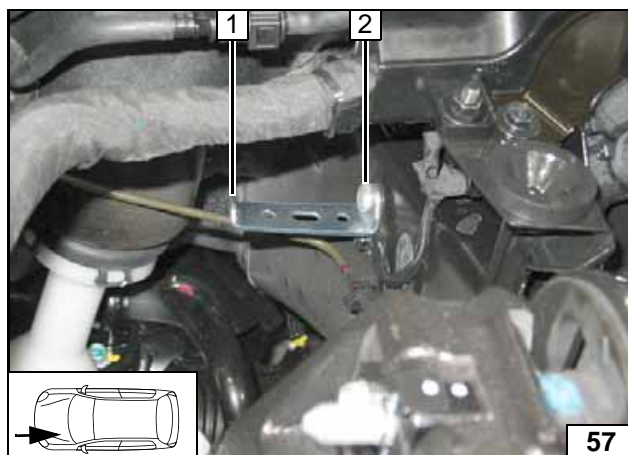

- 1 Perforated bracket
- 2 M8x20 bolt, spring lockwasher, existing threaded hole

Installing perforated bracket

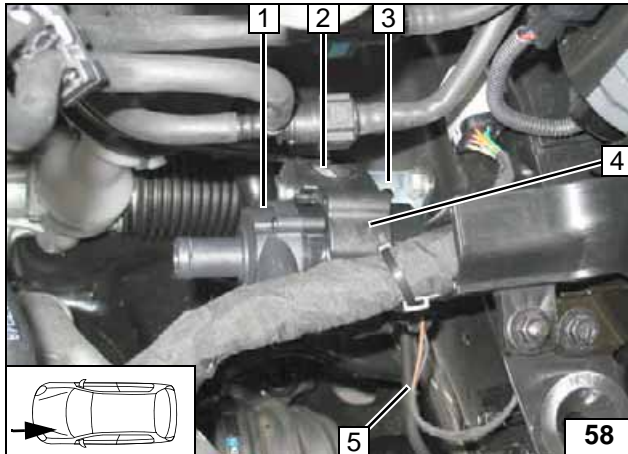

- 1 Circulating pump
- 2 M6x25 bolt, flanged nut
- 3 Perforated bracket
- 4 Circulating pump mount
- 5 Install circulating pump wiring harness

Installing circulating pump

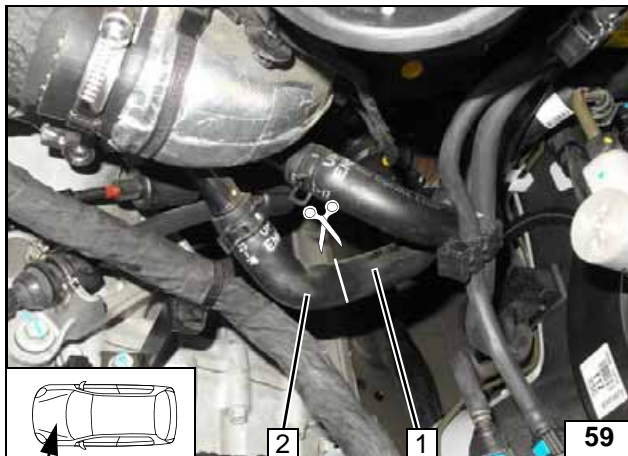

Cut hose of engine outlet/heat exchanger inlet along the marking.



- 1 Heat exchanger inlet hose section
- 2 Hose section of engine outlet

Cutting point

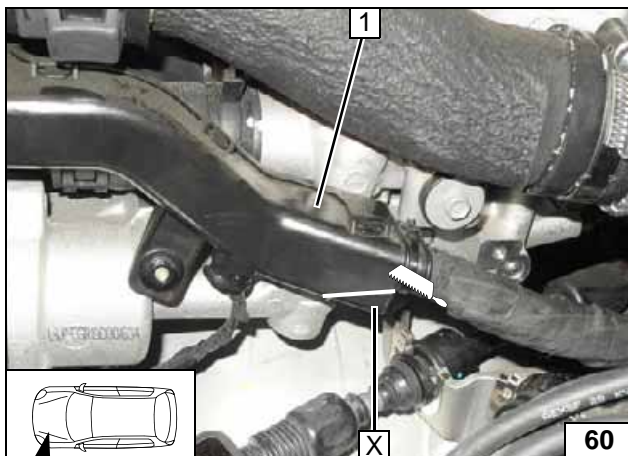

Cut original vehicle cable duct 1 as shown.



X=

Preparing the cable duct

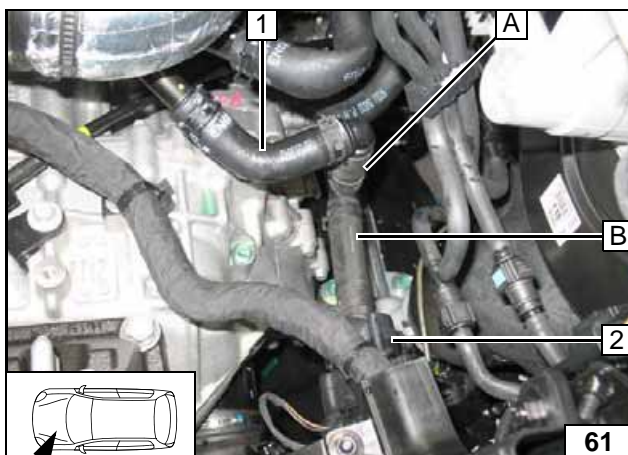

- 1 Hose section of engine outlet
- 2 Circulating pump

Connecting engine outlet / circulating pump

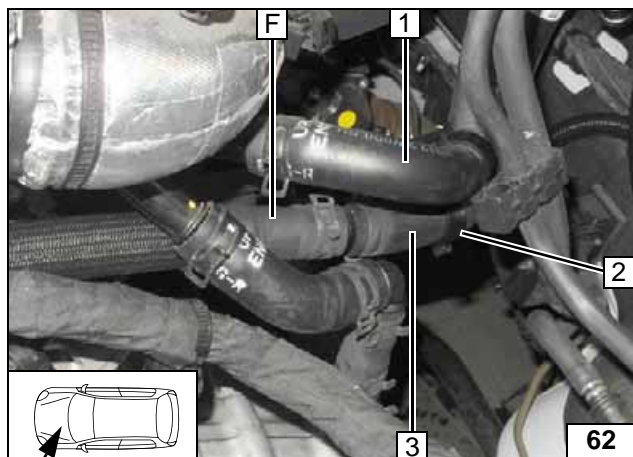

- 1 Hose of heat exchanger outlet
- 2 Hose bracket
- 3 Heat exchanger inlet hose section

Connect-
ing heat ex-
changer
inlet

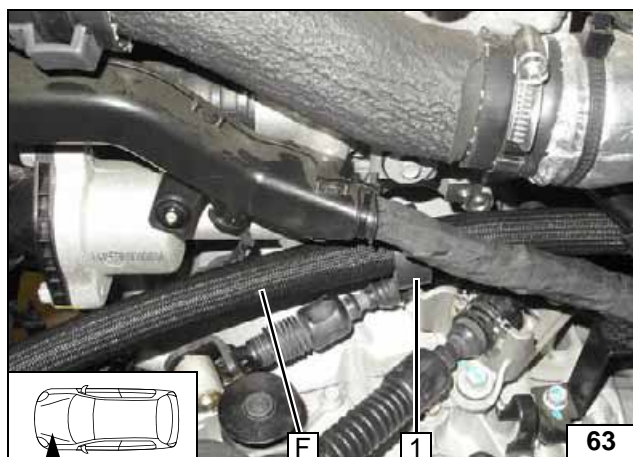

- 1 Align black (sw) rubber isolator with original vehicle wiring harness

Routing in
engine
compart-
ment

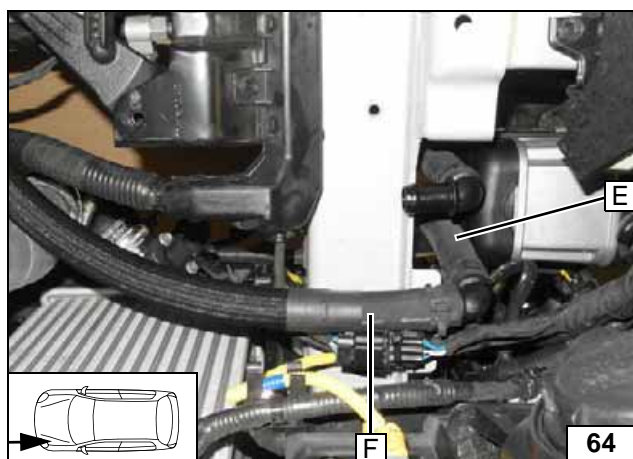

Connect-
ing heater
outlet

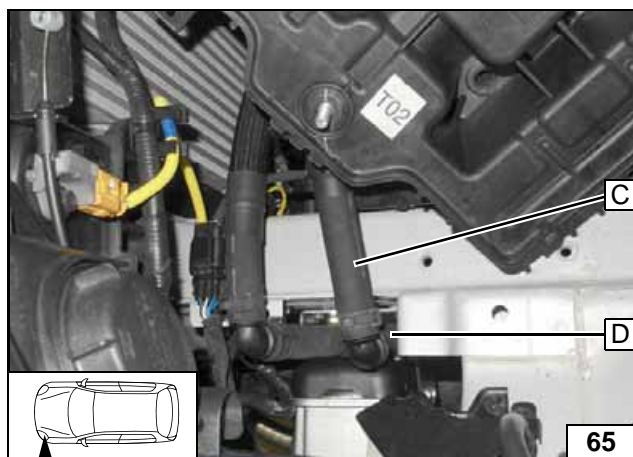

Connect-
ing heater
inlet

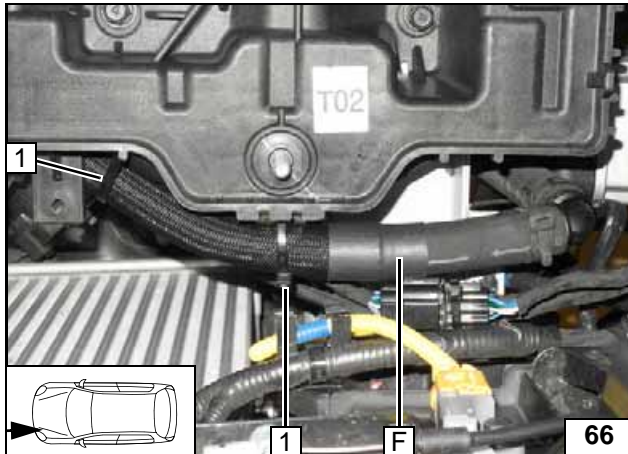
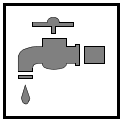

Install battery box. Align hoses. Ensure sufficient distance from neighbouring components, correct if necessary.

- 1 Securely mount cable tie [2x]



Routing in engine compartment

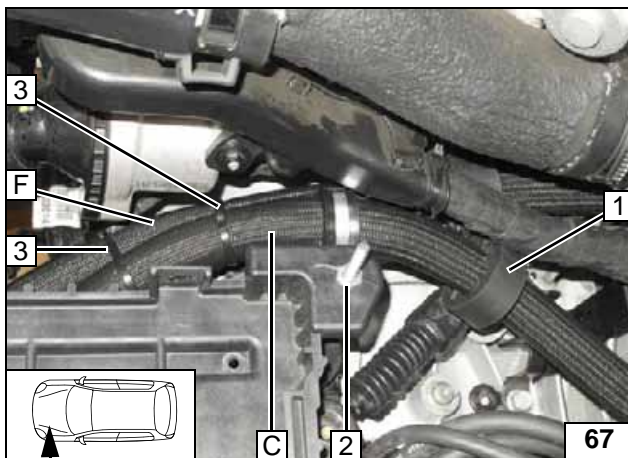

Slide black (sw) rubber isolator 1 onto hose C and align at gear stick linkage and the original vehicle wiring harness.

- 2 Tighten screw fitting of 29 mm dia. rubber-coated p-clamp
- 3 Cable tie [2x]



Routing in engine compartment

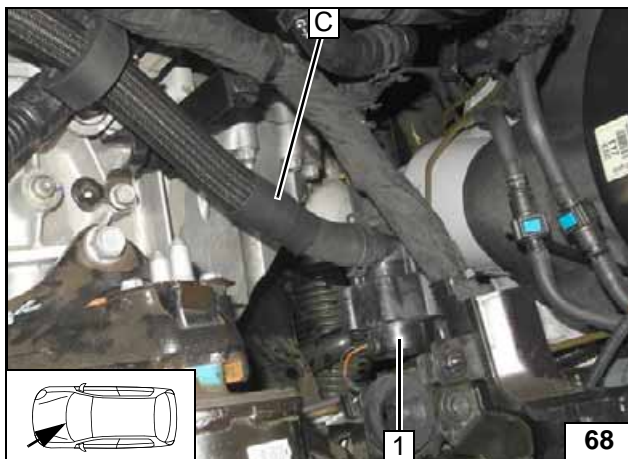

- 1 Circulating pump

Connecting circulating pump

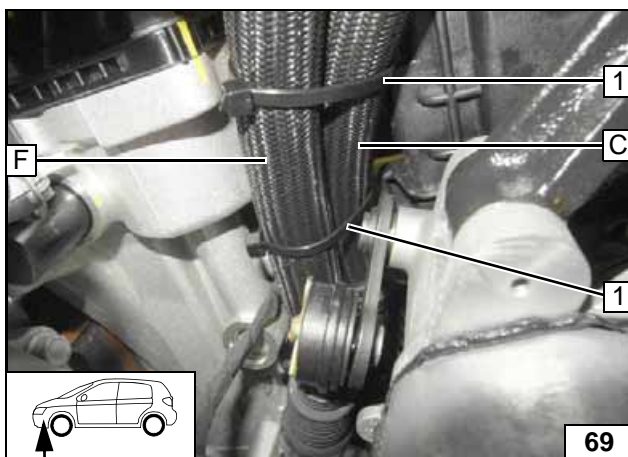

Ensure sufficient distance from gear stick linkage, correct if necessary.

- 1 Cable tie



Aligning hoses



2.2 D Only Front Heat Exchanger and AG



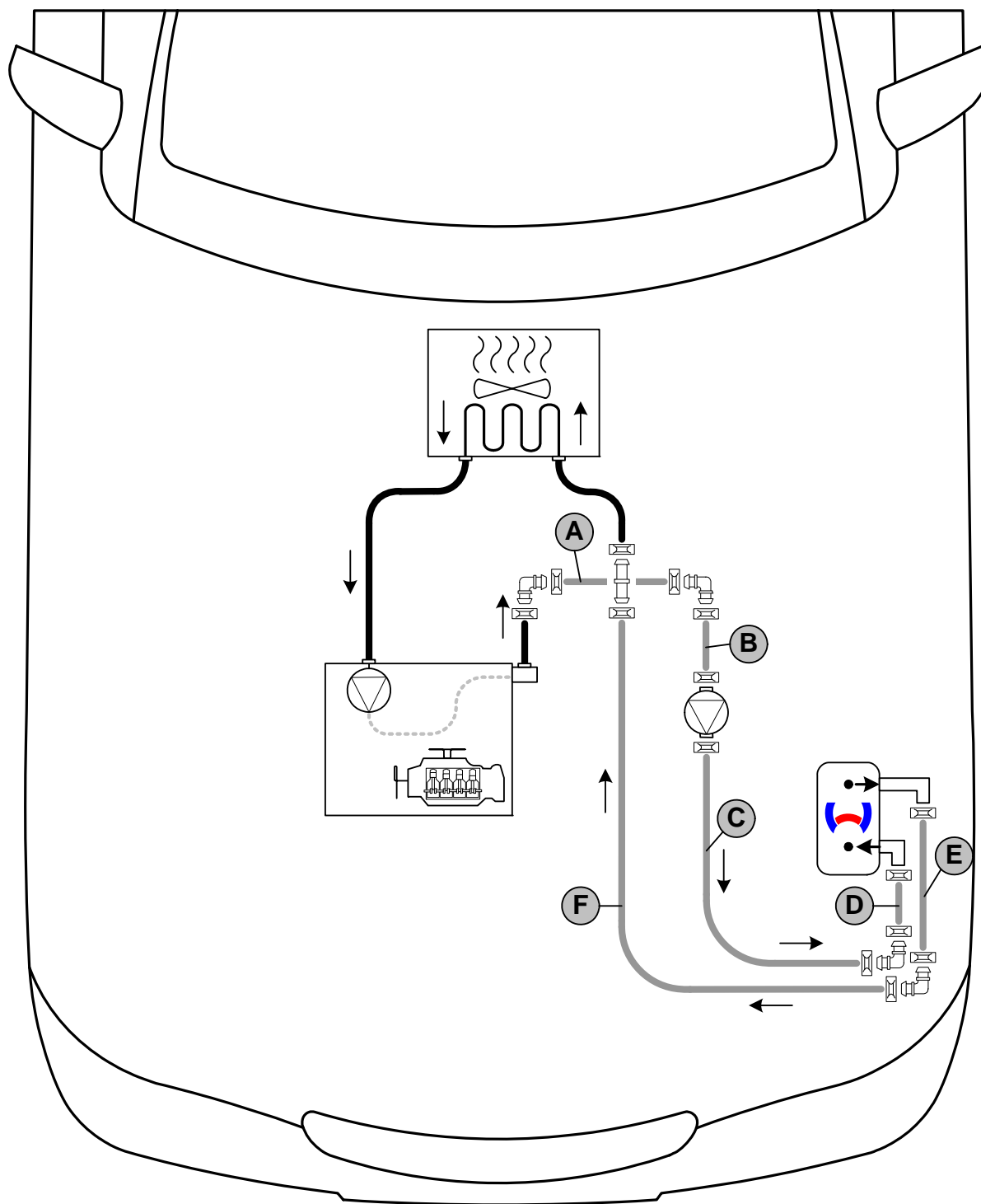

Any coolant running off should be collected in an appropriate container. Route hoses kink-free. Unless specified otherwise, always fasten using cable ties. Position clamps so that other hoses cannot be damaged. The heater must be filled with coolant when installing the hoses.

The connection should be modelled on an 'inline' circuit and based on the following diagram:



Hose routing diagram

All spring clips without a specific designation  = 25 mm dia.
 All connecting pipes  and  = 18x18 mm dia.



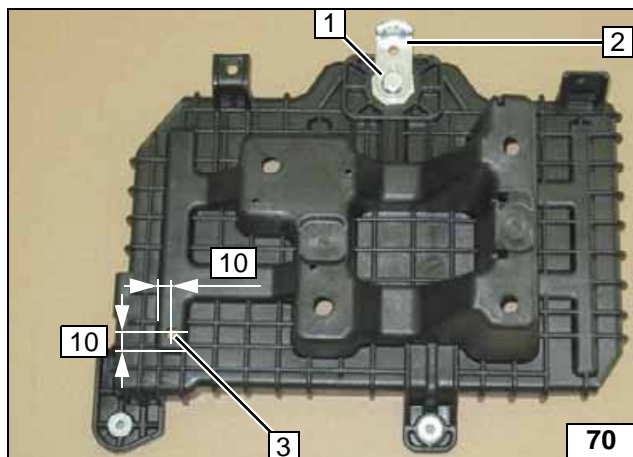

- 1 M8x40 bolt, spring lockwasher, existing threaded hole
- 2 Angle bracket
- 3 7 mm dia. hole

Preparing battery carrier

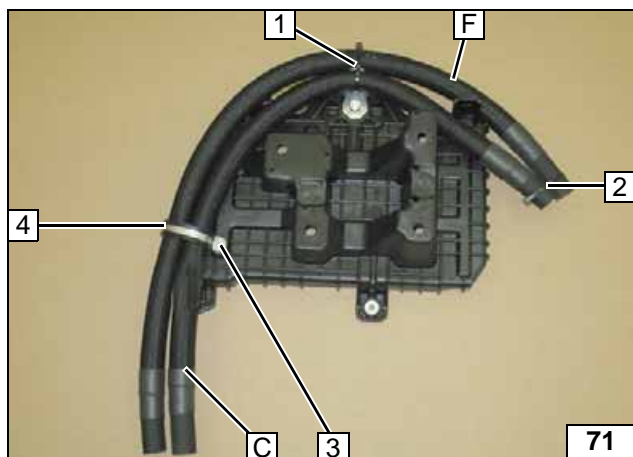

Loosely premount hoses below battery carrier as shown. Cable tie 1 and 38 mm dia. rubber-coated p-clamp 4 will be tightened later. Cable tie 2 is only used for fixation.



- 3 M6x20 bolt, flanged nut

Premounting battery carrier

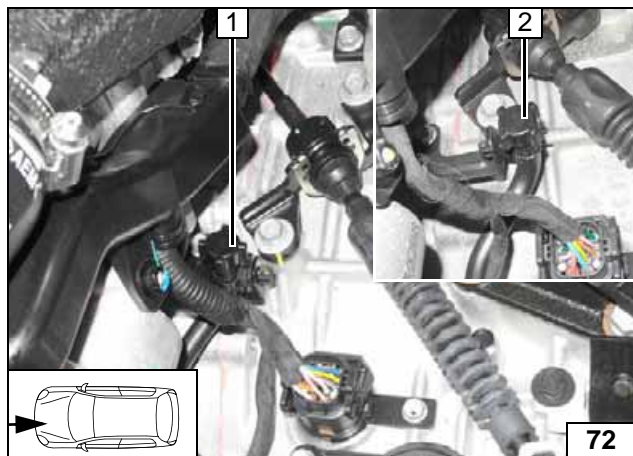

- 1 New position for transmission ventilation
- 2 Old position for transmission ventilation

Repositioning transmission ventilation

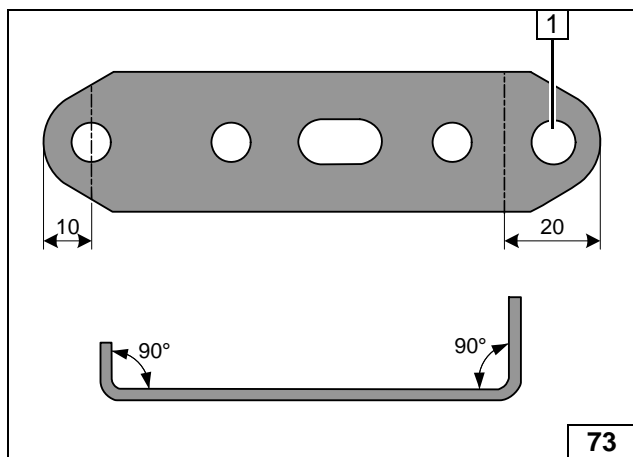

- 1 Drill out hole to 8.5 mm dia.

Preparing perforated bracket

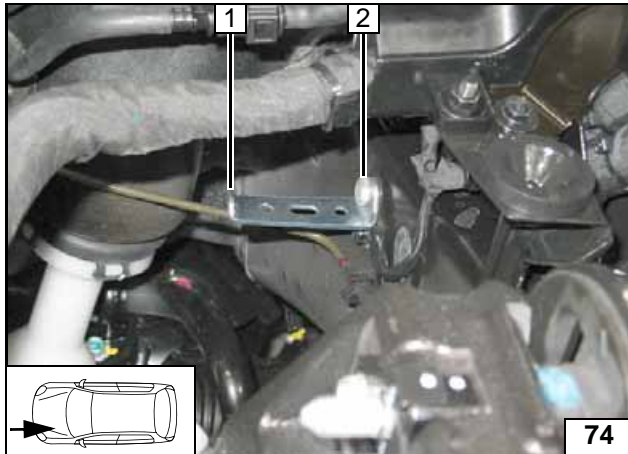

- 1 Perforated bracket
- 2 M8x20 bolt, spring lockwasher, existing threaded hole

Installing perforated bracket

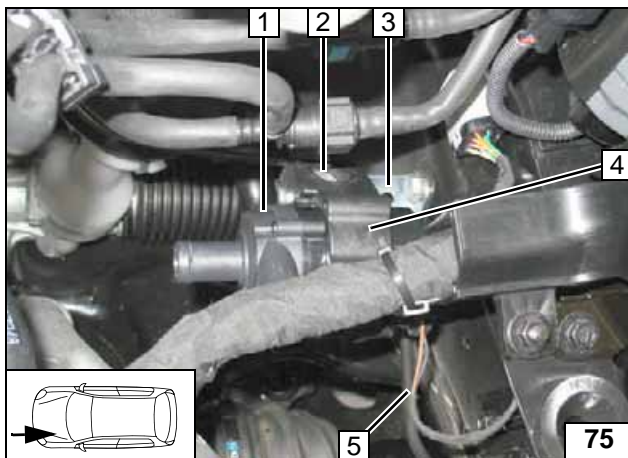

- 1 Circulating pump
- 2 M6x25 bolt, flanged nut
- 3 Perforated bracket
- 4 Circulating pump mount
- 5 Install circulating pump wiring harness

Installing circulating pump

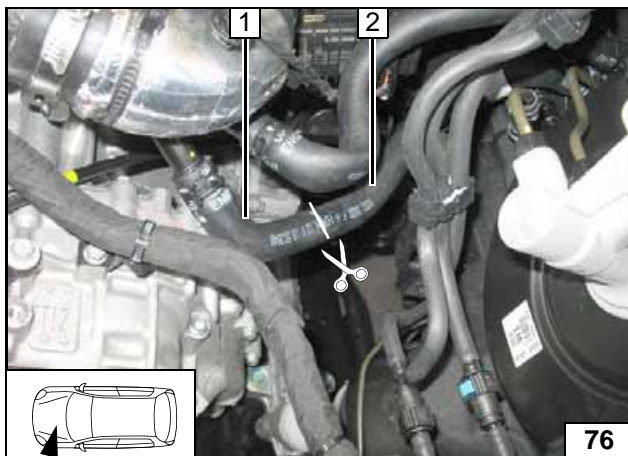

Cut off hose on engine outlet/heat exchanger inlet at marking.

- 1 Hose section of engine outlet
- 2 Heat exchanger inlet hose section



Cutting point

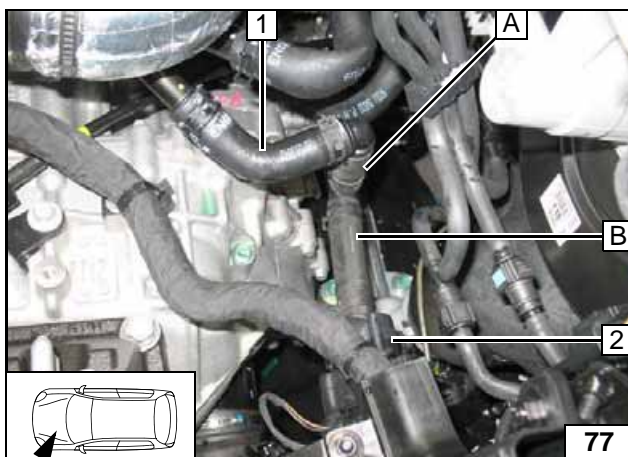

- 1 Hose section of engine outlet
- 2 Circulating pump

Connecting engine outlet

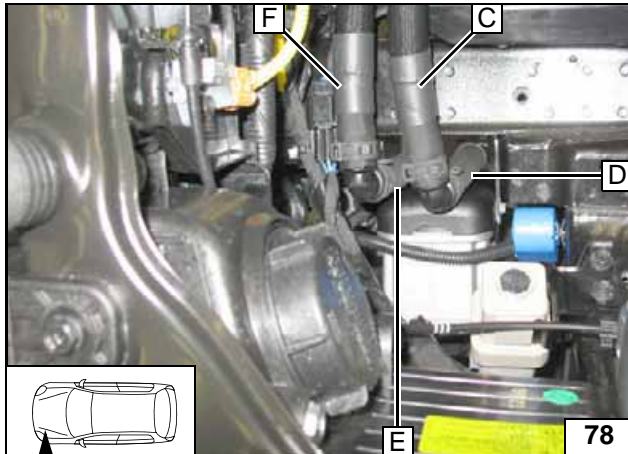

Connect-
ing heater

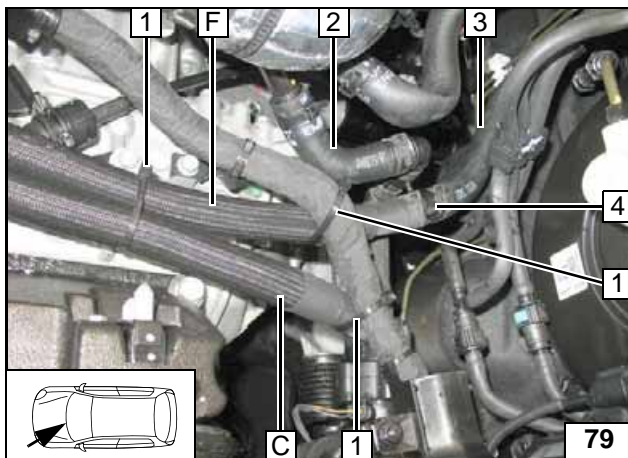

- 1 Cable tie [3x]
- 2 Hose section of engine outlet
- 3 Heat exchanger inlet hose section
- 4 Hose bracket

Connect-
ing hose C
and F

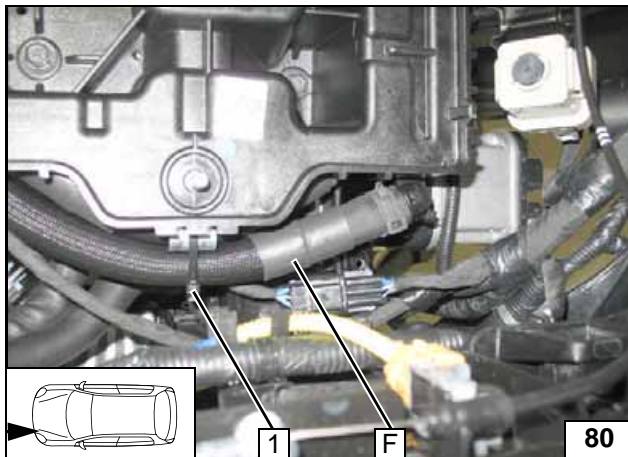

Install battery box. Align hoses. Ensure sufficient distance from neighbouring components, correct if necessary.



- 1 Securely mount cable tie

Routing in
engine
compart-
ment

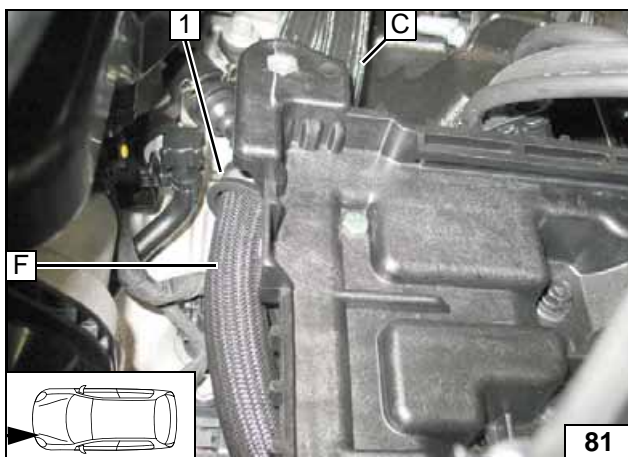

- 1 Tighten screw fitting of 38 mm dia. rubber-coated p-clamp

Routing in
engine
compart-
ment

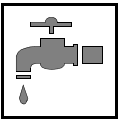

2.2 D with Front / Rear Heat Exchanger and AG



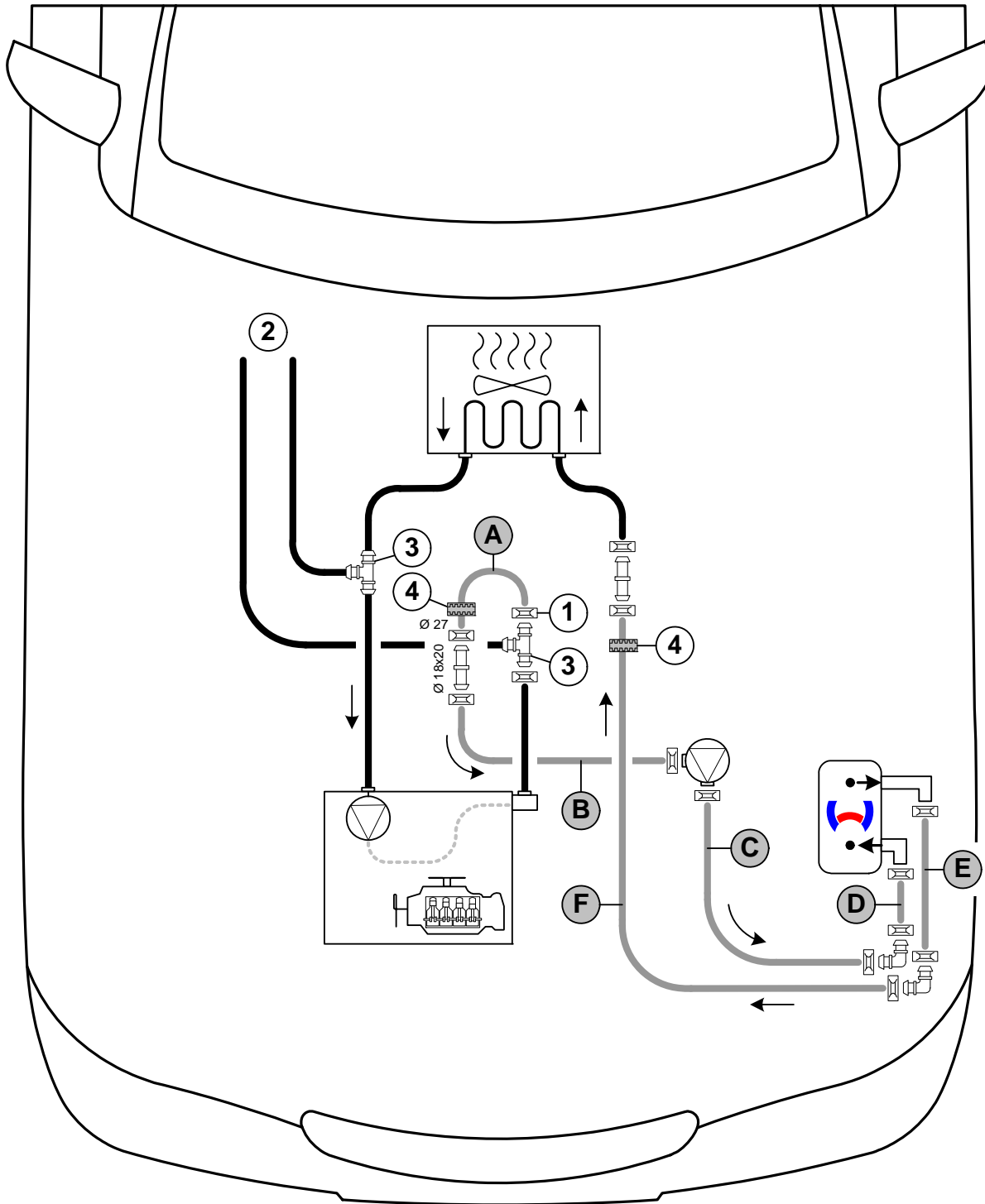

Any coolant running off should be collected in an appropriate container. Route hoses kink-free. Unless specified otherwise, always fasten using cable ties. Position clamps so that other hoses cannot be damaged. The heater must be filled with coolant when installing the hoses.

The connection should be modelled on an 'inline' circuit and based on the following diagram:





Hose routing diagram

All spring clips without a specific designation  = 25 mm dia.

All connecting pipes without a specific designation  and  = 18x18 mm dia.

1 = Original vehicle spring clip .

2 = Connection of second heat exchanger. 3 = Original vehicle T-piece . 4 = Black (sw) rubber isolator .



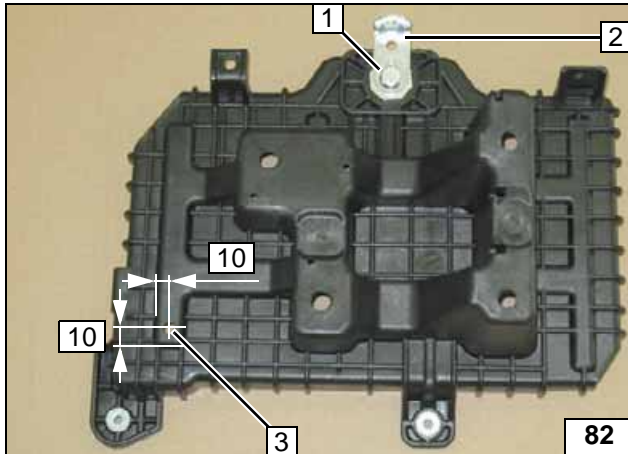

- 1 M8x40 bolt, spring lockwasher, existing threaded hole
- 2 Angle bracket
- 3 7 mm dia. hole

Preparing battery carrier

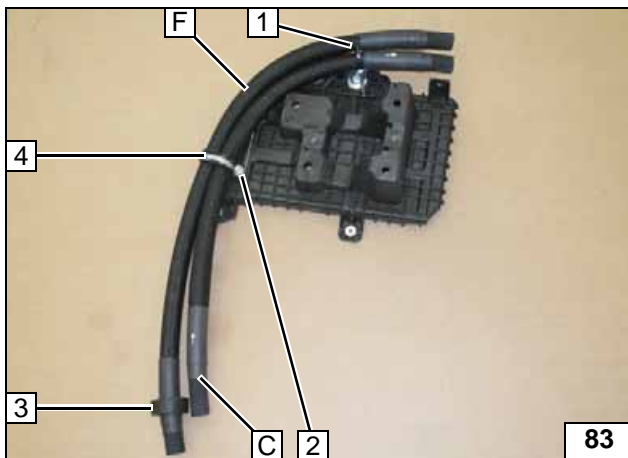

Loosely premount hoses below battery carrier as shown. Cable tie 1 and 38 mm dia. rubber-coated p-clamp 4 will be tightened later.



- 2 M6x20 bolt, flanged nut
- 3 Slide on black (sw) rubber isolator

Premounting battery carrier

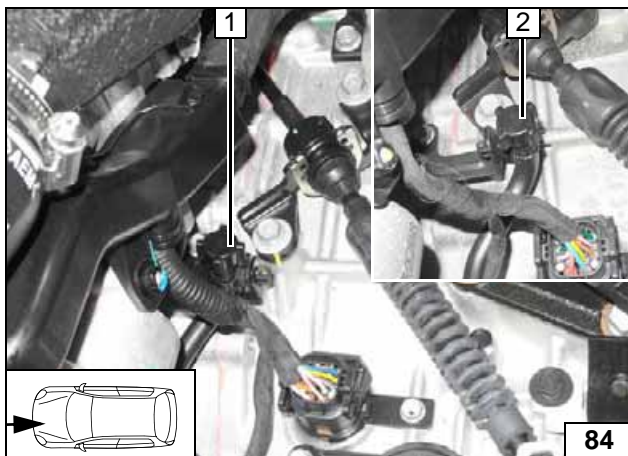

- 1 New position for transmission ventilation
- 2 Old position for transmission ventilation

Repositioning transmission ventilation

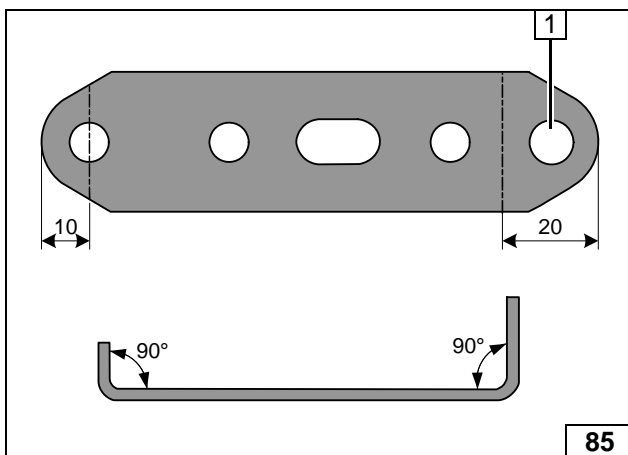

- 1 Drill out hole to 8.5 mm dia.

Preparing perforated bracket

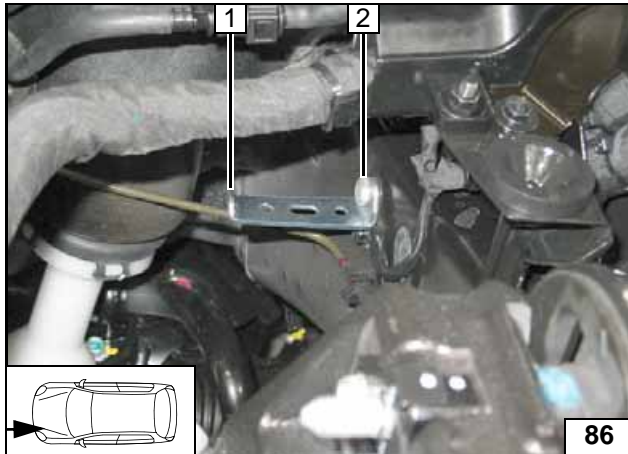

- 1 Perforated bracket
- 2 M8x20 bolt, spring lockwasher, existing threaded hole

Installing perforated bracket

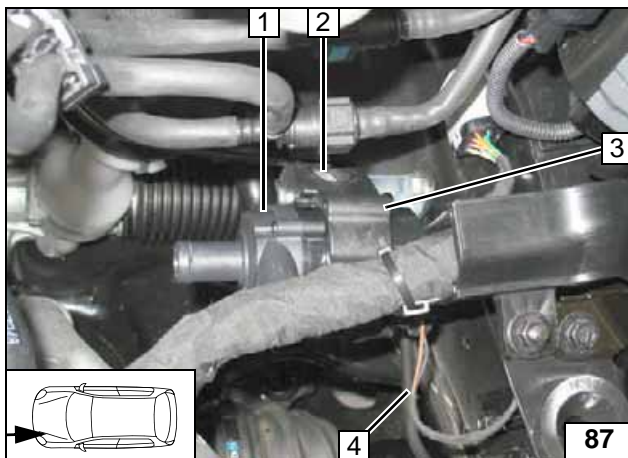

- 1 Circulating pump
- 2 M6x25 bolt, flanged nut
- 3 Circulating pump mount
- 4 Install circulating pump wiring harness

Installing circulating pump

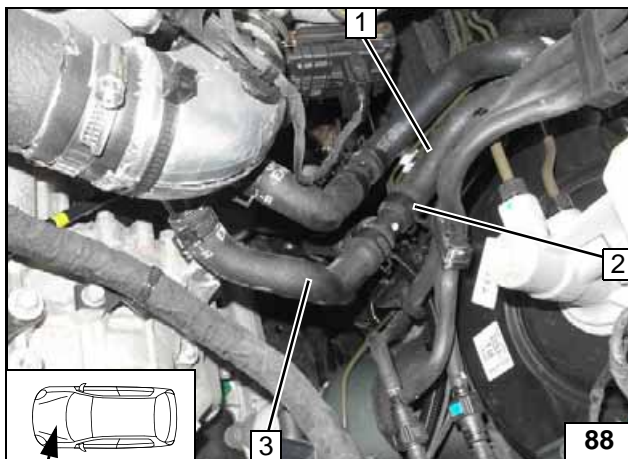

Pull off hose on T-piece to front heat exchanger inlet 1. Spring clip 2 will be reused.



- 3 Hose section of engine outlet

Cutting point

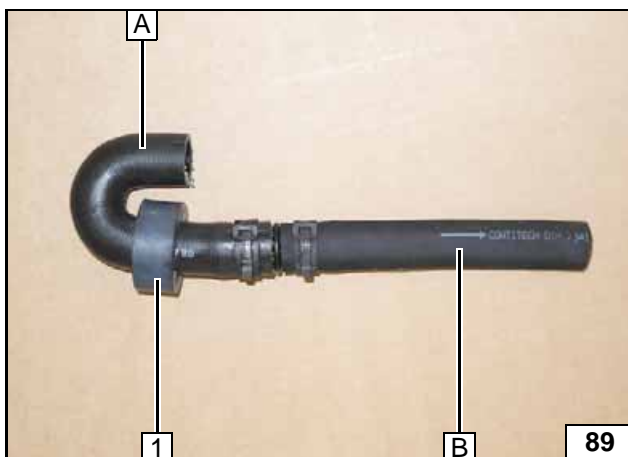

- 1 Slide on black (sw) rubber isolator

Preparing hoses

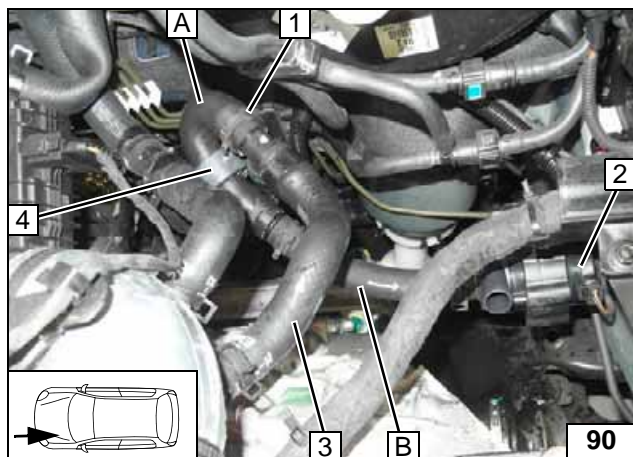

- 1 Original vehicle spring clip
- 2 Circulating pump
- 3 Hose section of engine outlet
- 4 Align rubber isolator with engine inlet hose section

Connect-
ing engine
outlet

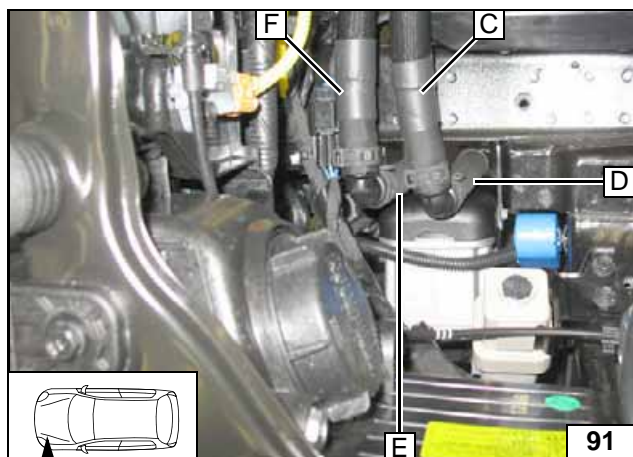

Connect-
ing heater

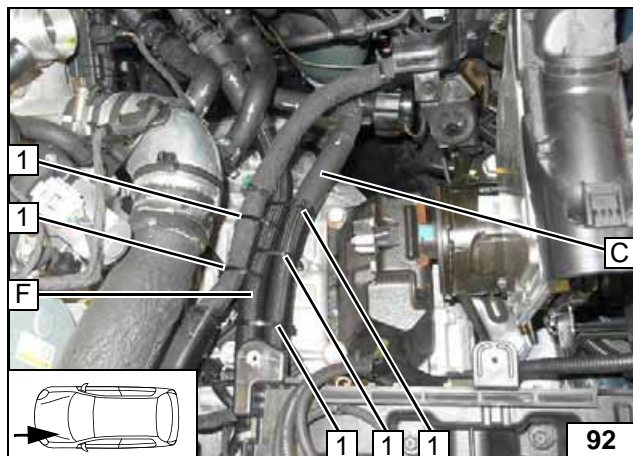

Install battery box. Align hoses. Ensure sufficient distance from neighbouring components, correct if necessary.



- 1 Cable tie [5x]

Connec-
tion of hose
C

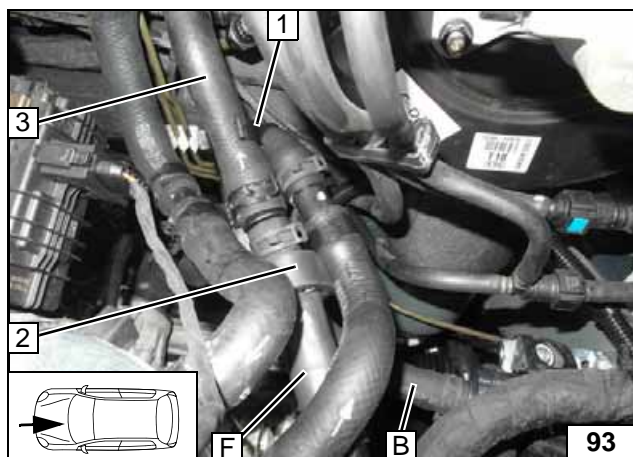

Ensure sufficient distance from neighbouring components, correct if necessary.



- 1 Hose bracket
- 2 Align black (sw) rubber isolator between hose B and hose of engine inlet
- 3 Heat exchanger inlet hose section

Connect-
ing heat ex-
changer
inlet

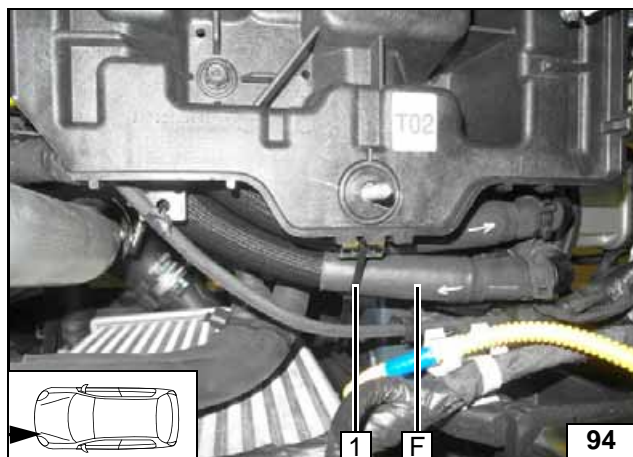

1 Securely mount cable tie

Routing in engine compartment

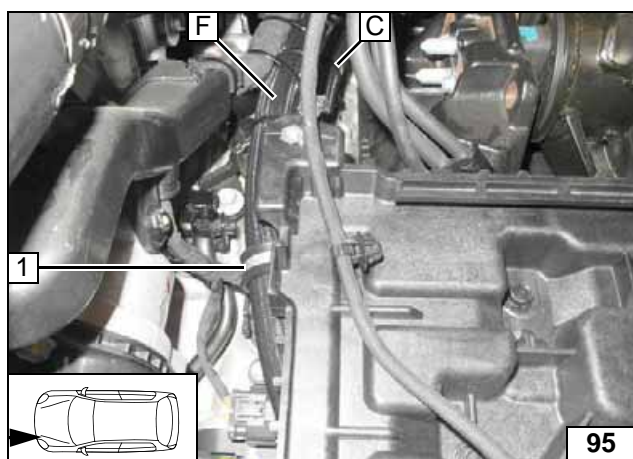

1 Tighten screw fitting of 38 mm dia. rubber-coated p-clamp

Routing in engine compartment

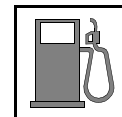

Fuel



Open the vehicle's fuel tank cap, ventilate the tank and then re-close the tank lock.

Catch any fuel running off in an appropriate container.



Route fuel line and metering pump wiring harness so that they are protected against stone impact. Unless specified otherwise, always fasten using cable ties.

Provide rub protection for fuel line and wiring harness in areas where there are sharp edges.

The fuel line and wiring harness are routed to the metering pump as shown in the wiring harness routing diagram.

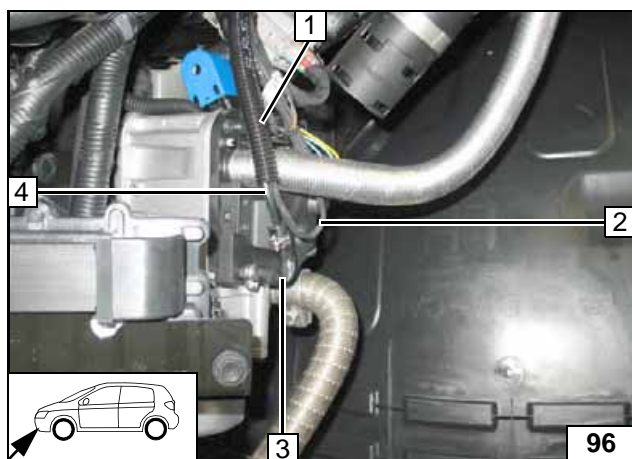

Cut one end of 10 mm dia., 2100 mm long corrugated tube to length by 200 mm (will be needed to connect the metering pump). Pull fuel line 4 and wiring harness of metering pump 2 into 1900 mm long corrugated tube 1 and route to the firewall.

3 90° moulded hose, 10mm dia. clamp [2x]



**Connect-
ing heater**

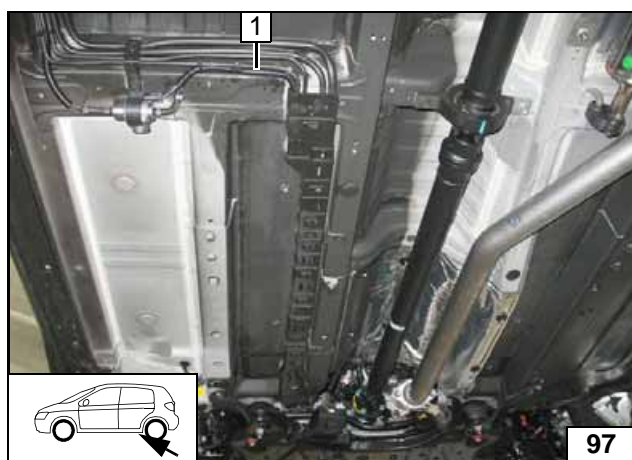

Route fuel line and wiring harness of metering pump on original vehicle fuel lines in the original vehicle cable duct to the installation location of the metering pump. Slide 10 mm dia., 200 mm long corrugated tube 1 onto fuel line and wiring harness of metering pump.



**Routing
lines**

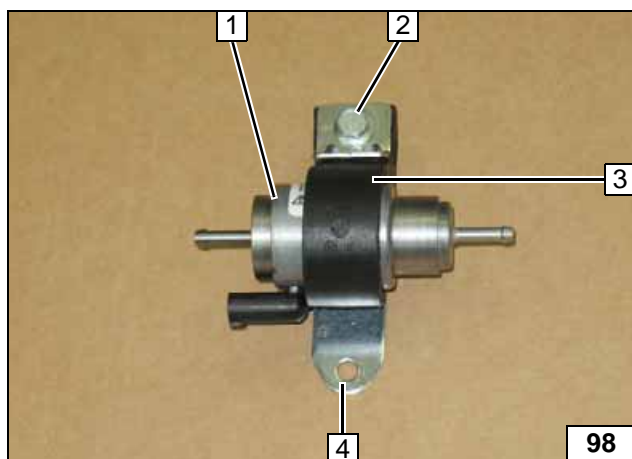

1 Metering pump
2 M6x25 bolt, support angle bracket, perforated bracket 4, flanged nut
3 Metering pump mount

**Premount-
ing meter-
ing pump**

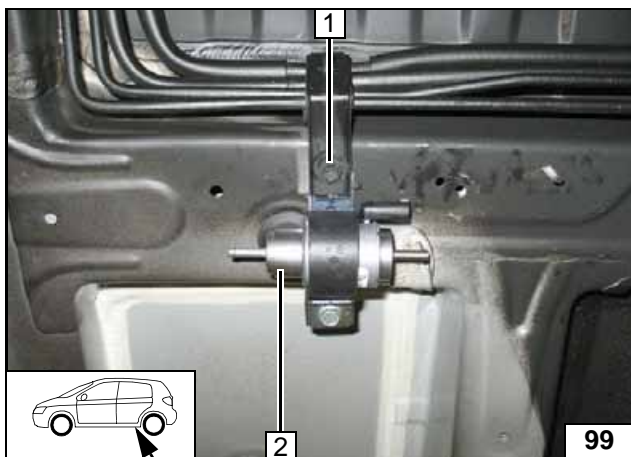

- 1 Original vehicle bolt
- 2 Metering pump



Installing metering pump

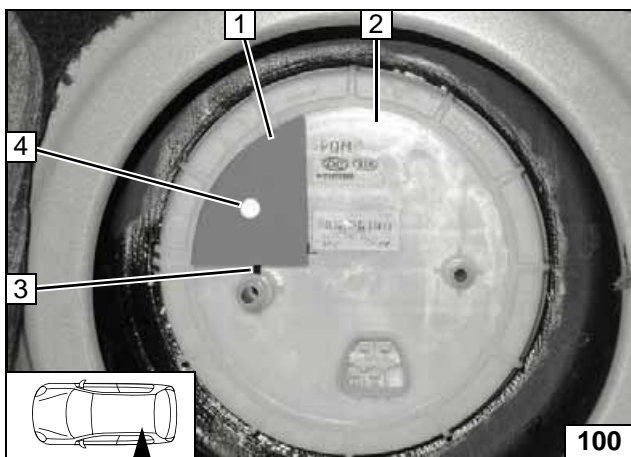

Installing FuelFix

Work steps F1 and F2.

Cut out template 1 and position onto fuel tank sending unit 2 as shown.

- 3 Position at raised part of connection piece
- 4 Copy hole pattern



Copying hole pattern



Work step F3.

- 1 Hole made with provided drill

Hole for FuelFix

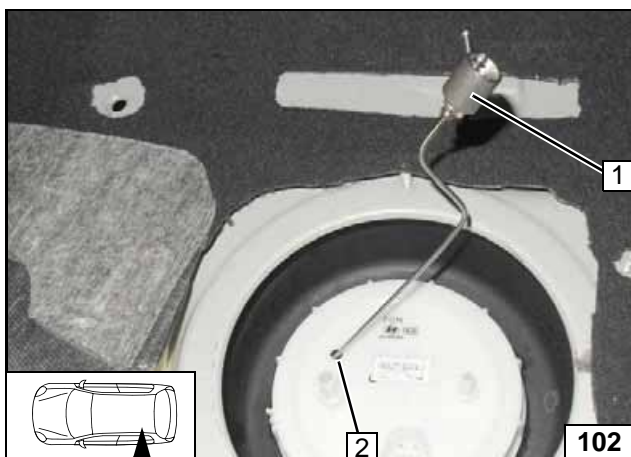

Work steps F4 and F5.

Bend FuelFix 1 according to template and cut to length. Insert into hole 2.



Inserting FuelFix



Work step F5.



Inserting
FuelFix

Inserting
FuelFix

Inserting
FuelFix

Inserting
FuelFix

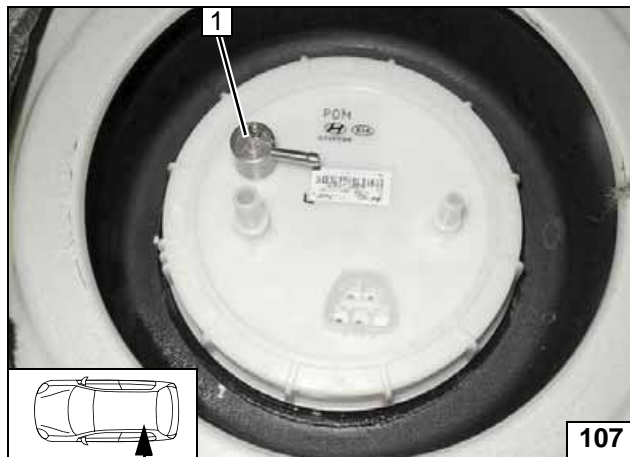

Work steps F5.3 and F5.4.

Align FuelFix 1 as shown.



Aligning FuelFix

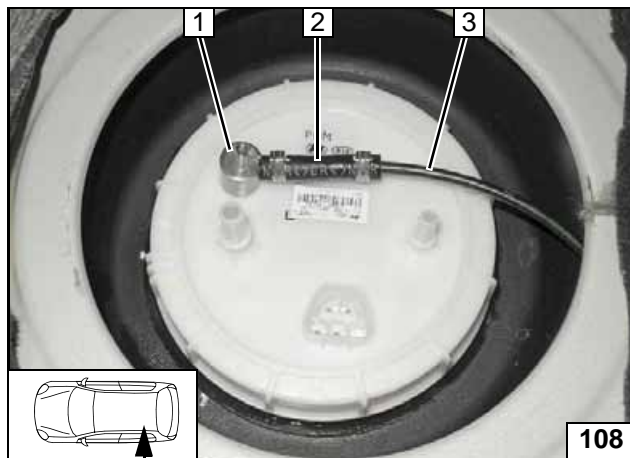

Work step F6.

- 1 FuelFix
- 2 Hose section, 10mm dia. clamp [2x]
- 3 Fuel line of FuelFix

Connect-ing fuel line

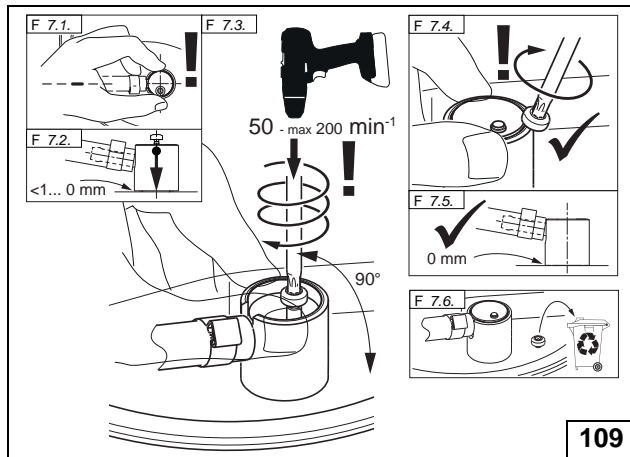

Work step F7.



Installing FuelFix



Work step F8.

Install original vehicle fuel lines. Attach fuel line of FuelFix to original vehicle fuel line using a cable tie for strain relief.



Ensuring firm seating of FuelFix

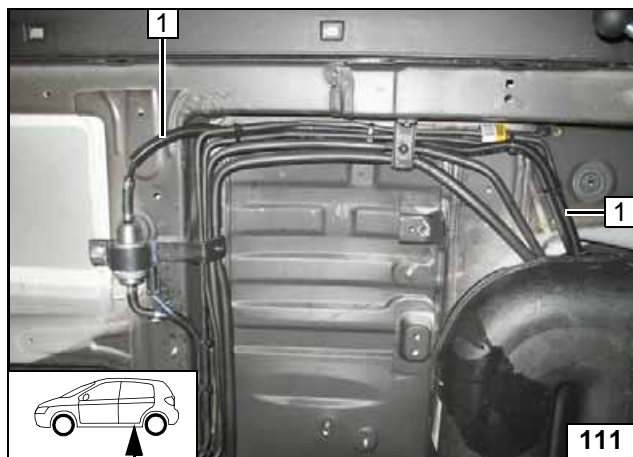

Route fuel line of FuelFix in 10mm dia., 1130mm long corrugated tube **1** to the metering pump.



Routing lines

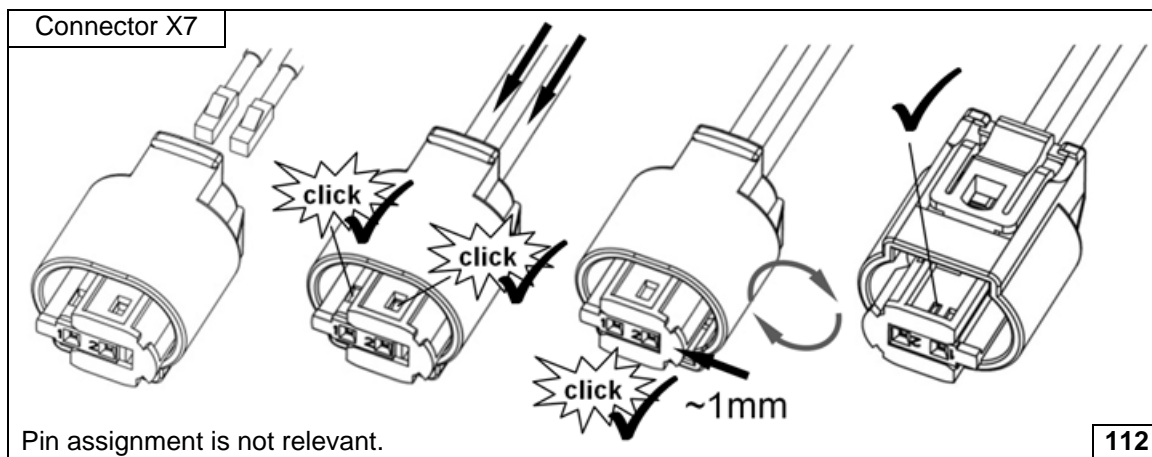

Pin assignment is not relevant.

112

Completing metering pump connector

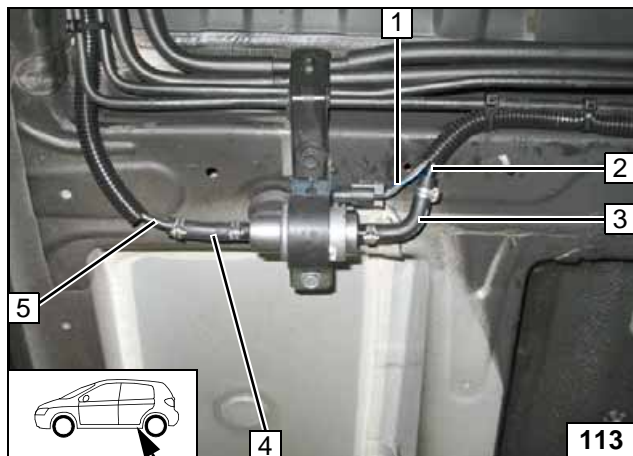

Ensure sufficient distance from neighbouring components, correct if necessary.

- 1 Wiring harness of metering pump, connector X7 mounted
- 2 Fuel line of heater
- 3 90° moulded hose, 10mm dia. clamp [2x]
- 4 Hose section, 10mm dia. clamp [2x]
- 5 Fuel line of FuelFix



Connecting metering pump



Ensure sufficient distance at position **1**



Installing underdrive protection

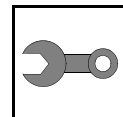

Final Work



Reassemble the components in reverse order. Check all hoses, clamps and all electrical connections for firm seating. Insulate and tie back loose lines. Only use manufacturer-approved coolant. Spray the heater components with anti-corrosion wax (Tectyl 100K).

- Connect the battery.
- Fill and bleed the coolant circuit according to the vehicle manufacturer's specifications.
- Program MultiControl CAR, teach Telearstart transmitter.
- Make settings on the A/C control panel according to the 'operating instructions'.
- Place the 'Switch off parking heater before refuelling' caution label near the filler neck.
- For initial startup and function check, please see installation instructions.

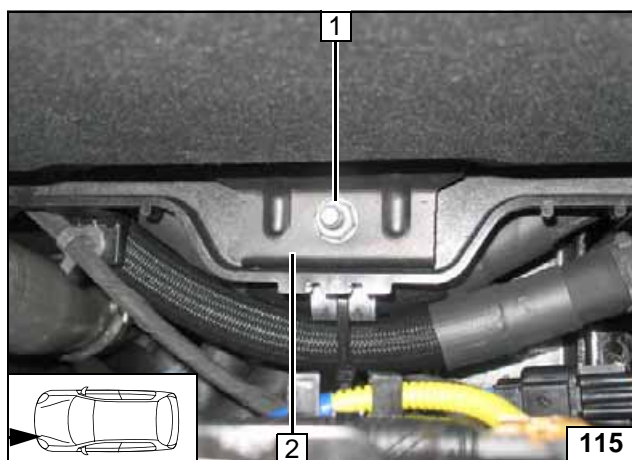

All vehicles

- 1 M8 flanged nut
- 2 Retaining plate of battery

Installing battery

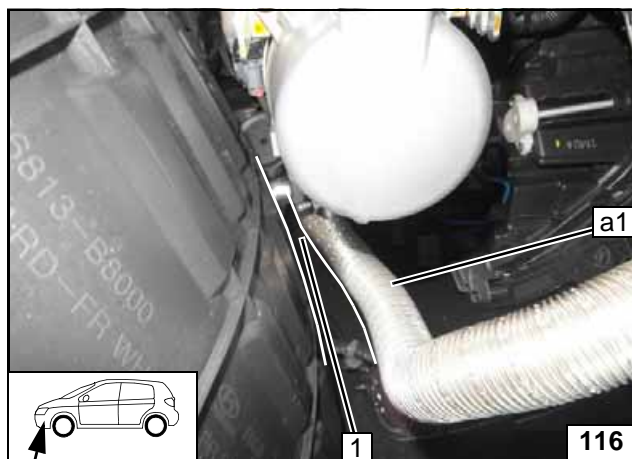

Ensure sufficient distance between exhaust pipe a1 and wheel well trim at position 1 (at least 20mm), correct if necessary.



Aligning exhaust pipe a1

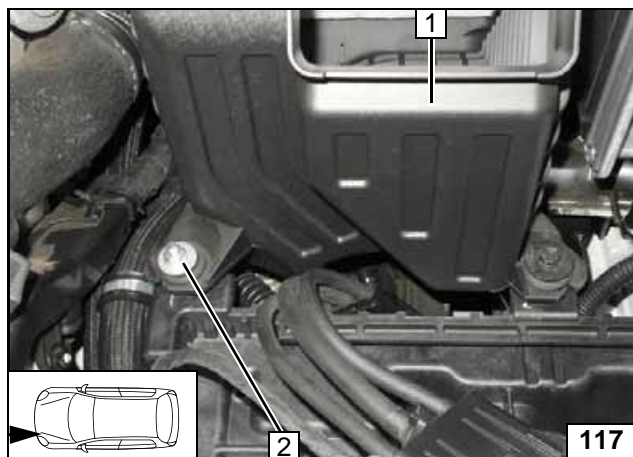
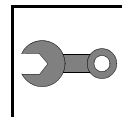

Only for 2.0 D / 2.2 D SG

- 1 Air filter box
- 2 Large diameter washer, M6 flanged nut

**Mounting
air filter
box**

Webasto Thermo & Comfort SE
Postfach 1410
82199 Gilching
Germany
Internet: www.webasto.com
Technical Extranet:
<http://dealers.webasto.com>



Fuel Tank Sending Unit Template

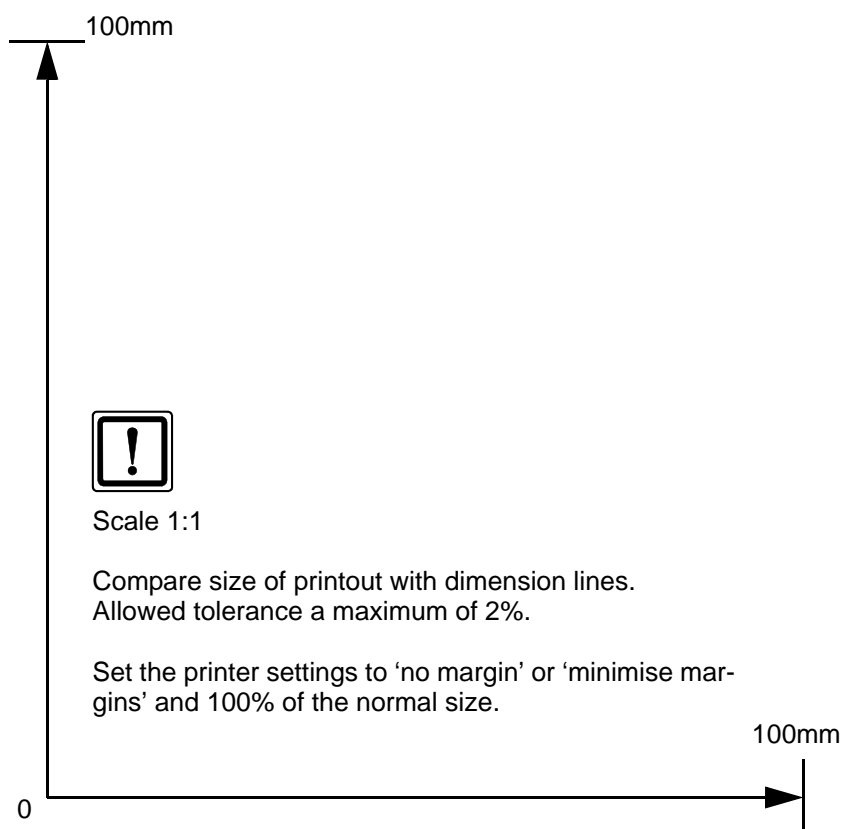
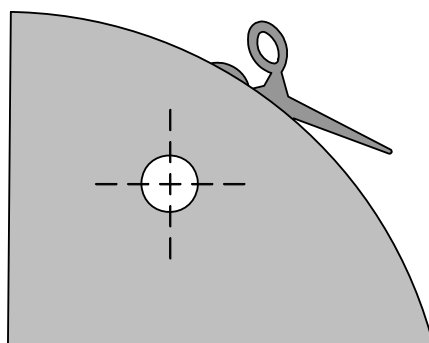



FuelFix Template

Top view

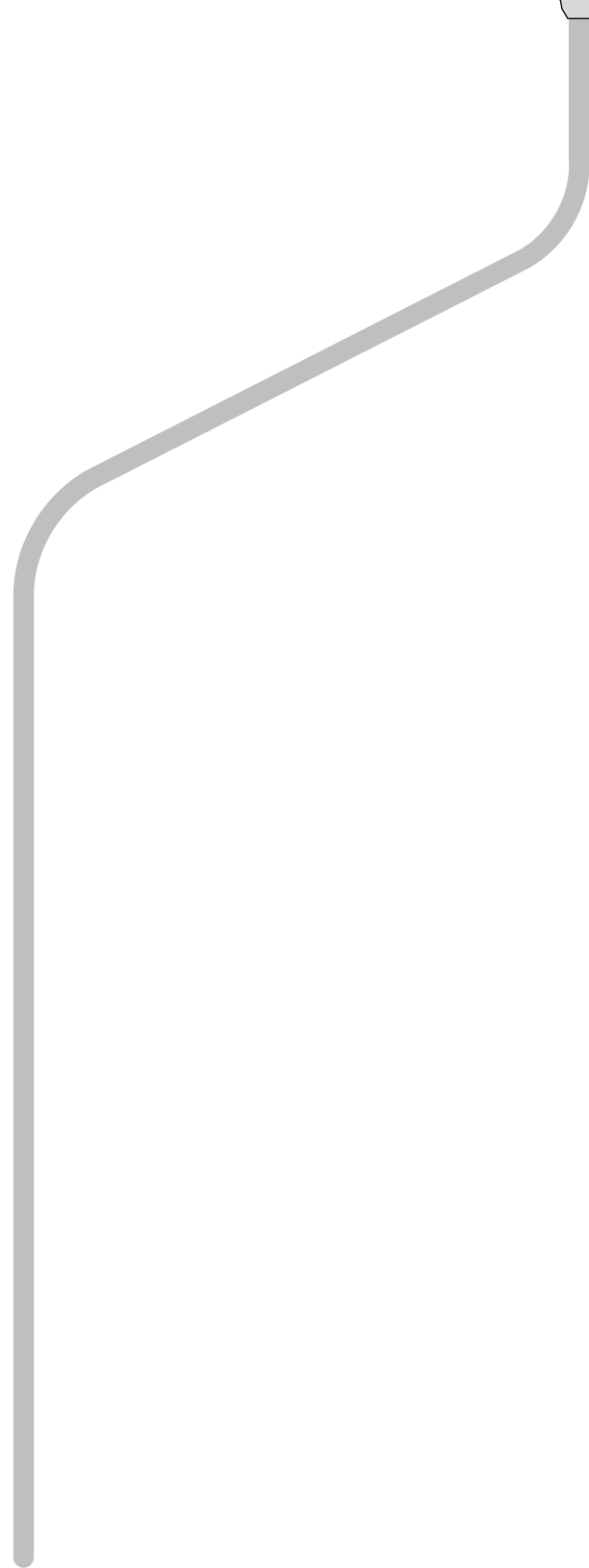
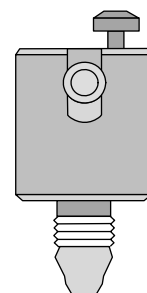

100mm



Scale 1:1

Compare size of printout with dimension lines.
Allowed tolerance a maximum of 2%.

Set the printer settings to 'no margin' or 'minimise margins' and 100% of the normal size.

0

100mm

Operating Instructions up to Model Year 2014

Please remove page and add to the vehicle operating instructions.

Note:

We recommend matching the heating time to the driving time.

Heating time = driving time

Example:

For a driving time of approx. 20 min. (in one direction), we recommend not exceeding a switch-on time of 20 min.

Passenger compartment monitoring, if installed, must be deactivated in addition to the vehicle settings for the heating operation.

For instructions on deactivation, please refer to the operating instructions of the vehicle.

Before parking the vehicle, make the following settings:



- 1 Switch off 'rear' (fan of rear heat exchanger, if present).
- 2 Air outlet to 'windscreen / footwell'.
- 3 Set temperature on both sides to 'HI'
- 4 Set fan to level '2' max. '3'

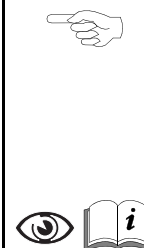

A/C control panel

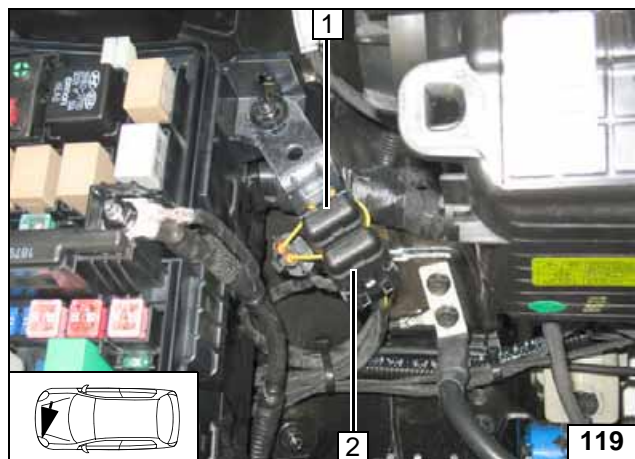

- 1 30A main fuse F2 of passenger compartment
- 2 20A heater fuse F1

Engine compartment fuses

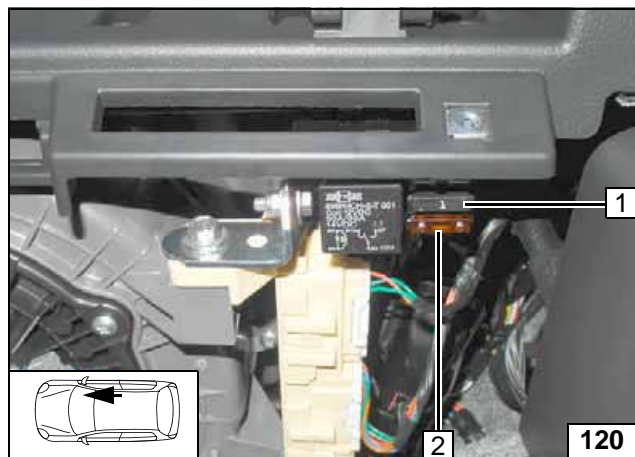

- 1 1A fuse F3 of heater control
- 2 7.5A fan fuse F4

Passenger compartment fuses



Operating Instructions from Model Year 2015

Please remove page and add to the vehicle operating instructions.

Note:

We recommend matching the heating time to the driving time.
 Heating time = driving time

Example:

For a driving time of approx. 20 min. (in one direction), we recommend not exceeding a switch-on time of 20 min.

Passenger compartment monitoring, if installed, must be deactivated in addition to the vehicle settings for the heating operation.

For instructions on deactivation, please refer to the operating instructions of the vehicle.

Before parking the vehicle, make the following settings:

- 1 Air outlet to 'windscreen / footwell'.
- 2 Set temperature on both sides to 'HIGH'
- 3 Set fan to level '2', max. '3'



A/C control panel

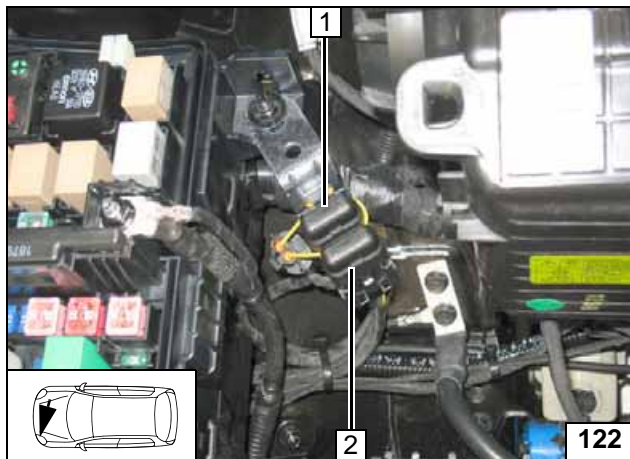

- 1 30A main fuse F2 of passenger compartment
- 2 20A heater fuse F1

Engine compartment fuses

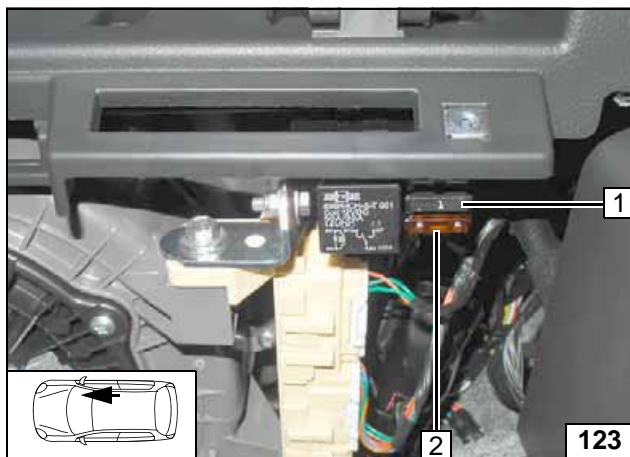

- 1 1A fuse F3 of heater control
- 2 7.5A fan fuse F4

Passenger compartment fuses

