

Water-Heater

Thermo Top Evo Parking Heater



Installation Documentation Citroen C5

Validity

Manufacturer	Model	Type	EG-BE No. / ABE
Citroen	C5	R...	e1 * 2001 / 116 * 0360 * ...

Motorisation	Fuel	Transmission type	Output in kW	Displacement in cm ³	Engine code
1.6 eHDI	Diesel	EGS6	82	1560	9HR

EGS6 = Electronically controlled 6-gear transmission

From Model Year 2012

Left-hand drive vehicle

Verified equipment variants: Automatic air-conditioning

Front fog light
Front fog lightStart-Stop

Not verified: Passenger compartment monitoring
Manual air-conditioning
Headlight washer system

Total installation time: approx. 9 hours

Citroen C5

Table of Contents

Validity	1	Preparing Installation Location	12
Necessary Components	2	Preparing Heater	15
Installation Overview	2	Installing Heater	16
Information on Total Installation Time	2	Exhaust Gas	17
Information on Operating and Installation Instructions	3	Coolant Circuit	19
Information on Validity	4	Fuel	23
Technical Information	4	Combustion Air	26
Explanatory Notes on Document	4	Final Work	27
Preliminary Work	5	Template for Fuel Standpipe	29
Heater Installation Location	5	Template for Bracket	30
Preparing Electrical System	6	Operating Instructions for End Customer	31
Electrical System	8		
Fan Controller	9		
Digital Timer	11		
Remote option (Telestart)	11		

Necessary Components

- Basic delivery scope of *Thermo Top Evo* based on price list
- Installation kit for Citroen C5 2012 1.6 Diesel: **1318818B**
- Heater control in accordance with price list and upon consultation with end customer
- In case of Telestart, indicator lamp in accordance with price list and in consultation with end customer

Installation Overview

Legend:

1. Heater
2. Fuse holder of engine compartment
3. Fuse holder of passenger compartment
4. Circulating pump
5. Digital Timer
6. Metering pump

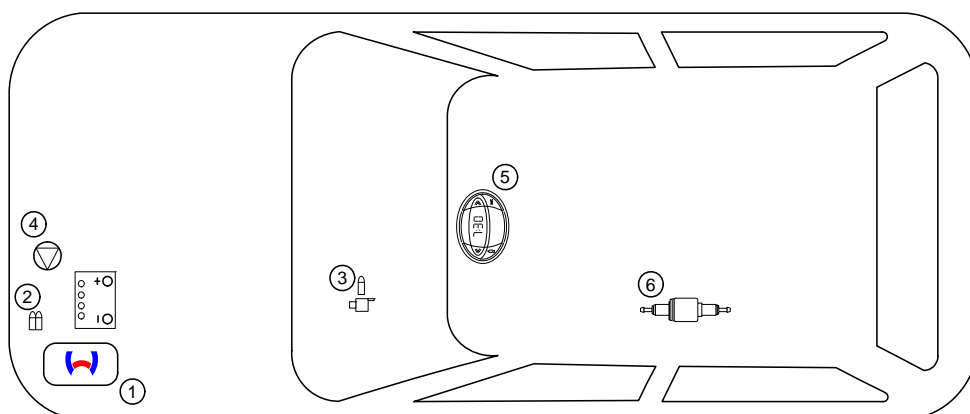

Information on Total Installation Time

The total installation time includes the time needed for mounting and demounting of the vehicle-specific components, the heater specific installation time and all other times required for the system integration and initial start-up of the heater.

The total installation time may vary for vehicle equipment other than provided.

Information on Operating and Installation Instructions

1 Important notes (not complete)

1.1 Installation and repair



The improper installation or repairing of Webasto heating and cooling systems can cause fire or the leakage of deadly carbon monoxide. This can lead to serious injury or death.



To install and repair Webasto heating and cooling systems you need to have completed a special company training course and have the appropriate technical documentation, special tools and special equipment.



Installation and repair may ONLY be carried out by persons trained and certified in a Webasto training course. NEVER try to install or repair Webasto heating or cooling systems if you have not completed a Webasto training course, you do not have the necessary technical skills and you do not have the technical documentation, tools and equipment available to ensure that you can complete the installation and repair work properly.

Only use genuine Webasto parts. See the Webasto air and water heaters accessories catalogue for this purpose.

1.2 Operation

To ensure safe operation, we recommend having the heater checked every two years by an authorised Webasto dealer, especially when used over a long period and/or under extreme environmental conditions.

Do not operate the heater in closed rooms due to the danger of poisoning and suffocation.

Always switch off the heater before refuelling.

The heater may only be used with the prescribed fuel Diesel (DIN EN 590) or petrol (DIN EN 227).

The heater may not be cleaned with a high-pressure cleaner.

1.3 Please note

ALWAYS follow all Webasto installation and operating instructions and observe all warnings.

To become familiar with and understand all functions and properties of the heater, the operating instructions must be read carefully and observed at all times.

For proper, safe installation and repair work, the installation instructions with all warnings and safety information must be carefully read and observed at all times. Please always contact a workshop authorised by Webasto for all installation and repair work.

Important

Webasto shall assume no liability for defects, damage and injuries resulting from a failure to observe the installation, repair and operating instructions of the information contained in them.

This liability exclusion particularly applies to improper installations and repairs, installations and repairs by untrained persons or in the case of a failure to use genuine spare parts.

The liability due to culpable disregard to life, limb or health and due to damage or injuries caused by a wilful or reckless breach of duty remain unaffected, as does the obligatory product liability.

Installation should be carried out according to the general, standard rules of technology. Unless specified otherwise, fasten hoses, wires and wiring harnesses to original vehicle lines and wiring harnesses using cable ties. Insulate loose wires and tie back. Connectors on electronic components have to audibly click into place during installation.

Sharp edges should be fitted with rub protection. Spray unfinished body areas, e.g. drilled holes, with anti-corrosion wax (Tectyl 100K, Order No. 111329).

Observe the instructions and guidelines of the respective vehicle manufacturer for demounting and mounting vehicle specific components!

The initial startup is to be executed with the Webasto Thermo Test Diagnosis.

When installing an IPCU, the corresponding settings must be checked or adjusted before the installation.

2 Statutory regulations governing installation

Guidelines	Thermo Top Evo
Heating Directive ECE R122	E1 00 0258
EMC Directive ECE R10	E1 03 5627

Note

The regulations of these guidelines are binding in the scope of the Directive 70/156/EEC and/or 2007/46/EC (for new vehicle models from 29/04/2009) and should also be observed in countries in which there are no special regulations.

Important

Failure to follow the installation instructions will result in the invalidation of the type approval for the heater and therefore invalidation of the general **homologation of the vehicle**.

Note

For vehicles with an EU permit, no entry in accordance with § 19 Sub-Section 4 of Annex VIII b to the Road Traffic Act is required.

2.1 Excerpt from the directive 2001/56/EC Appendix VII for the installation of the heater

Beginning of excerpt.

ANNEX VII

REQUIREMENTS FOR COMBUSTION HEATERS AND THEIR INSTALLATION

1. GENERAL REQUIREMENTS

1.7.1. A clearly visible tell-tale in the operator's field of view shall inform when the combustion heater is switched on or off.

2. VEHICLE INSTALLATION REQUIREMENTS

2.1. Scope

2.1.1. Subject to paragraph 2.1.2. combustion heaters shall be installed according to the requirements of this Annex.

2.1.2. Vehicles of category O having liquid fuel heaters are deemed to comply with the requirements of this Annex.

2.2. Positioning of heater

2.2.1. Body sections and any other components in the vicinity of the heater must be protected from excessive heat and the possibility of fuel or oil contamination.

2.2.2. The combustion heater shall not constitute a risk of fire, even in the case of overheating. This requirement shall be deemed to be fulfilled if the installation ensures an adequate distance to all parts and suitable ventilation, by the use of fire resistant materials or by the use of heat shields.

2.2.3. In the case of M2 and M3 vehicles, the heater must not be positioned in the passenger compartment. However, an installation in an effectively sealed envelope which also complies with the conditions in paragraph 2.2.2 may be used.

2.2.4. The label referred to in paragraph 1.4 or a duplicate, must be positioned so that it can be easily read when the heater is installed in the vehicle.

2.2.5. Every reasonable precaution should be taken in positioning the heater to minimise the risk of injury and damage to personal property.

2.3. Fuel supply

2.3.1. The fuel filler must not be situated in the passenger compartment and must be provided with an effective cap to prevent fuel spillage

2.3.2. In the case of liquid fuel heaters, where a supply separate to that of the vehicle is provided, the type of fuel and its filler point must be clearly labelled

2.3.3. A notice, indicating that the heater must be shut down before refuelling, must be affixed to the fuelling point. In addition a suitable instruction must be included in the manufacturer's operating manual.

2.4. Exhaust system

2.4.1. The exhaust outlet must be located so as to prevent emissions from entering the vehicle through ventilators, heated air inlets or opening windows.

2.5. Combustion air inlet

2.5.1. The air for the combustion chamber of the heater must not be drawn from the passenger compartment of the vehicle.

2.5.2. The air inlet must be so positioned or guarded that blocking by rubbish or luggage is unlikely.

2.6. Heating air inlet

2.6.1. The heating air supply may be fresh or recirculated air and must be drawn from a clean area not likely to be contaminated by exhaust fumes emitted either by the propulsion engine, the combustion heater or any other vehicle source.

2.6.2. The inlet duct must be protected by mesh or other suitable means.

2.7. Heating air outlet

2.7.1. Any ducting used to route the hot air through the vehicle must be so positioned or protected that no injury or damage could be caused if it were to be touched.

2.7.2. The air outlet must be so positioned or guarded that blocking by rubbish or luggage is unlikely.

End of excerpt.

In multilingual versions the German language is binding.

Citroen C5

Information on Validity

This installation documentation applies to Citroen C5 1.6 Diesel vehicles - for validity, see page 1 - from model year 2012 and later, assuming technical modifications to the vehicle do not affect installation, any liability claims excluded. Depending on the vehicle version and equipment, modifications may be necessary during installation with respect to these "installation instructions".

Vehicle and engine types, equipment variants and other specifications not listed in this installation documentation have not been tested. However, installation according to this installation documentation may be possible.

Technical Information

Special Tools

- Hose clamp pliers for auto-tightening hose clamps
- Hose clamp pliers for Clic hose clamps of type W
- Automatic wire stripper 0.2 - 6mm²
- Crimping pliers for cable lug / tab connector 0.5 - 6mm²
- Torque wrench for 2.0 - 10 Nm
- Hose clamping pliers
- Metric thread-setter kit
- Webasto Thermo Test Diagnosis with current software
- Peugeot Special Tool for Ultra-Capacity Discharge: S-1288

Dimensions

- All dimensions in mm.

Tightening torque values

- Tightening torque values of 5x13 heater bolts = 8Nm.
- Tightening torque values of 5x15 retaining plate of water connection piece bolts = 7Nm.
- Tighten other bolt connections in accordance with manufacturer's instructions or in accordance with state-of-the-art-technology.

Explanatory Notes on Document

To provide you with a quick overview of the individual working steps, you will find an identification mark on the outside top right corner of the page in question.

Special features are highlighted using the following symbols:

Mechanical system



Special risk of injury or fatal accidents.



Electrical System



Specific risk of damage to components.



Coolant Circuit

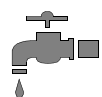

Specific risk of fire or explosion.



Combustion Air

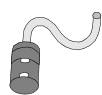

Reference to general installation instructions of the Webasto component or to vehicle specific documents of the manufacturer



Fuel



Reference to a special technical feature.



Exhaust gas



The arrow in the vehicle icon indicates the position on the vehicle and the viewing direction



Software

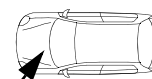

Citroen C5

Preliminary Work

Vehicle

- Open the fuel tank cap.
- Ventilate the fuel tank.
- Close the fuel tank cap again.
- De pressurise the cooling system.
- Completely remove the battery together with the carrier.
- Remove the air filter together with the intake hose.
- Remove the left front wheel.
- Remove the left-hand wheel well trim.
- Remove the left front underride protection.
- Remove the right-hand underbody trim.
- Remove the right rear underride protection.
- Remove the rear bench seat.
- Open the tank-fitting service lid.
- Remove the lower instrument panel trim on the driver's side.
- Remove the instrument panel trim on the driver's side (only with Telestart).
- Remove the footwell trim on the driver's side.
- Remove the driver's side storage compartment.

Heater

- Remove years that do not apply from the type and duplicate label.
- Attach the duplicate label (type label) in the appropriate place in the engine compartment.

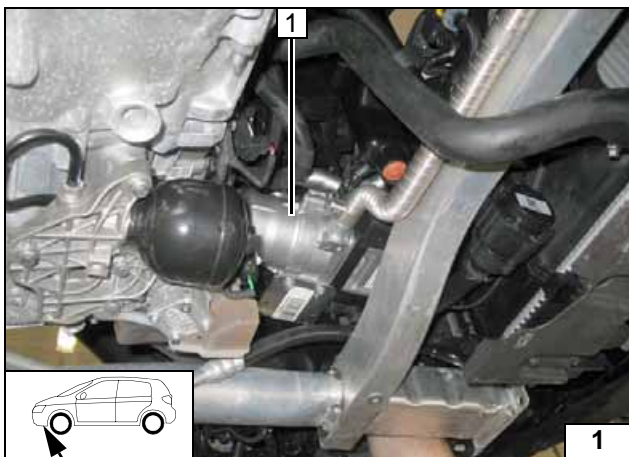

Heater Installation Location

- 1 Heater

Installation location

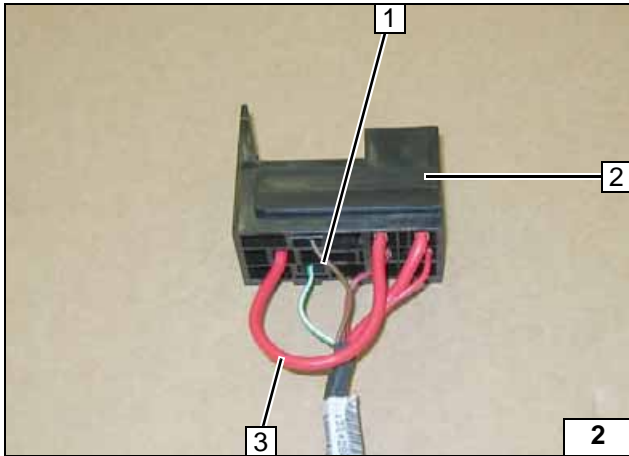
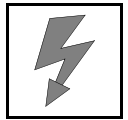

Preparing Electrical System

Remove brown (br) wire 1 from socket K1/85 and detach tab receptacle. Remove red (rt) wire 3 from K1/87 and socket F4 and discard.



2 Fuse holder of passenger compartment

Preparing fuse holder of passenger compartment

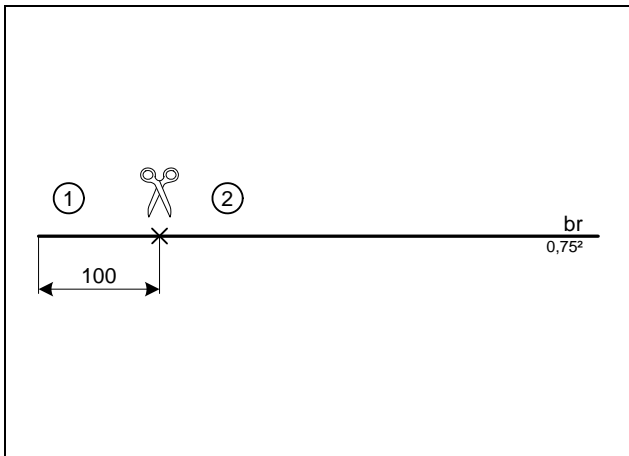

Cutting wire to length

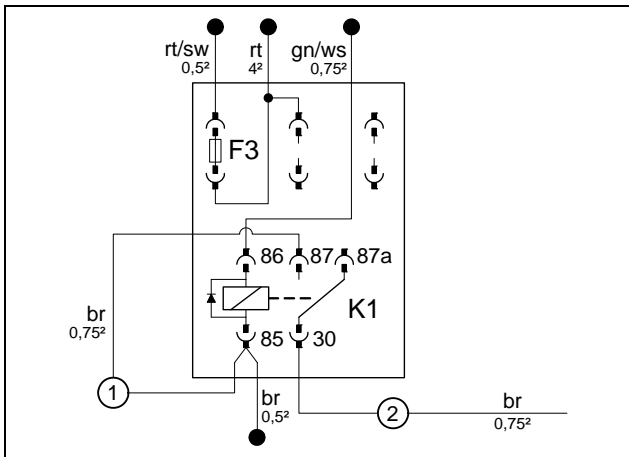

Connect brown (br) wire ① to K1/87 and connect with brown (br) wire to K1/85. Connect brown (br) wire ② to K1/30.



Preparing fuse holder of passenger compartment

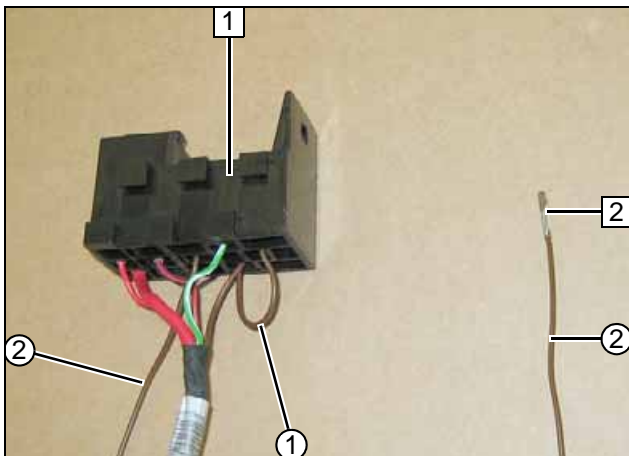

Crimp microtimer 2 to brown (br) wire ② .



- 1 Fuse carrier of passenger compartment
- ① Brown (br) wire of K1/87 - K1/85
- ② Brown (br) wire from K1/30

Preparing fuse holder of passenger compartment

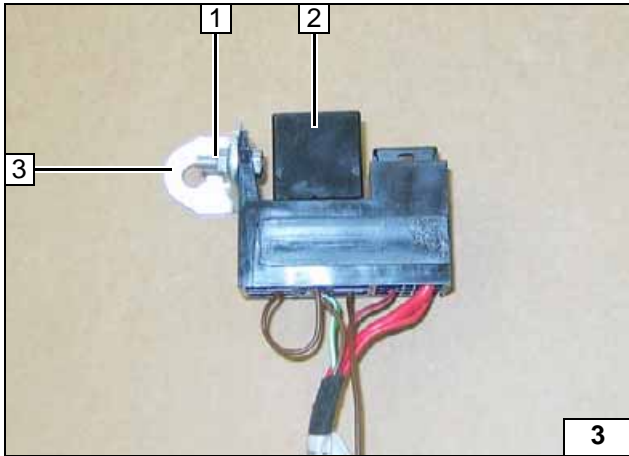

- 1 M5x16 bolt, large diameter washer [2x], nut
- 2 Relay mounted
- 3 Angle bracket

Preparing fuse holder of passenger compartment

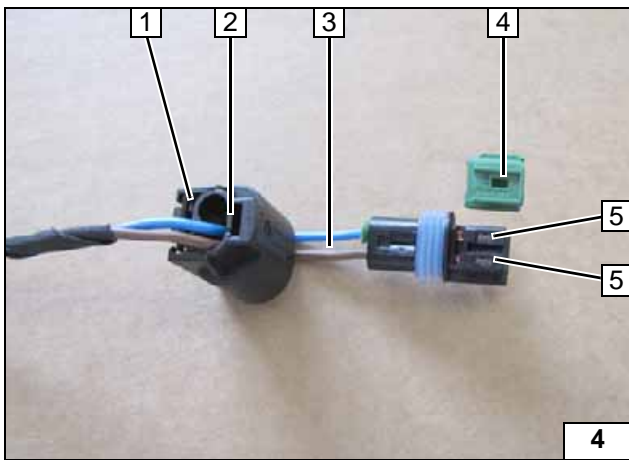

Complete connector of metering pump after routing. Pin assignment is not relevant.

- 1 Connector housing
- 2 Lock
- 3 Blue / brown (bl / br) wires
- 4 Coding
- 5 Timer lock



Dismantling connector



Electrical System

Fuse holder of engine compartment

- 1 Original vehicle bolt, large diameter washer
- 2 M5x16 bolt, large diameter washer [2x], retaining plate of fuse holder, nut
- 3 F1-2 fuses mounted
- 4 Angle bracket

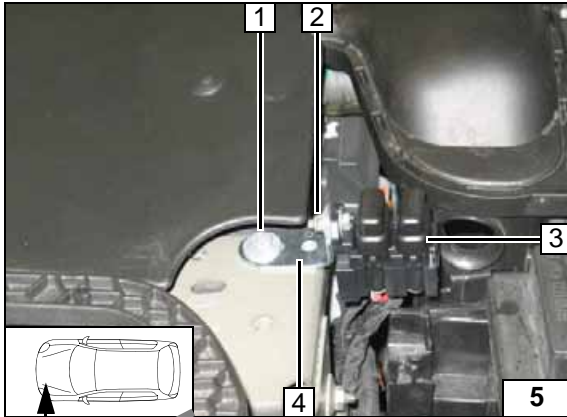

Positive and earth wire

- 1 Positive wire
- 2 Earth wire on original vehicle earth support point

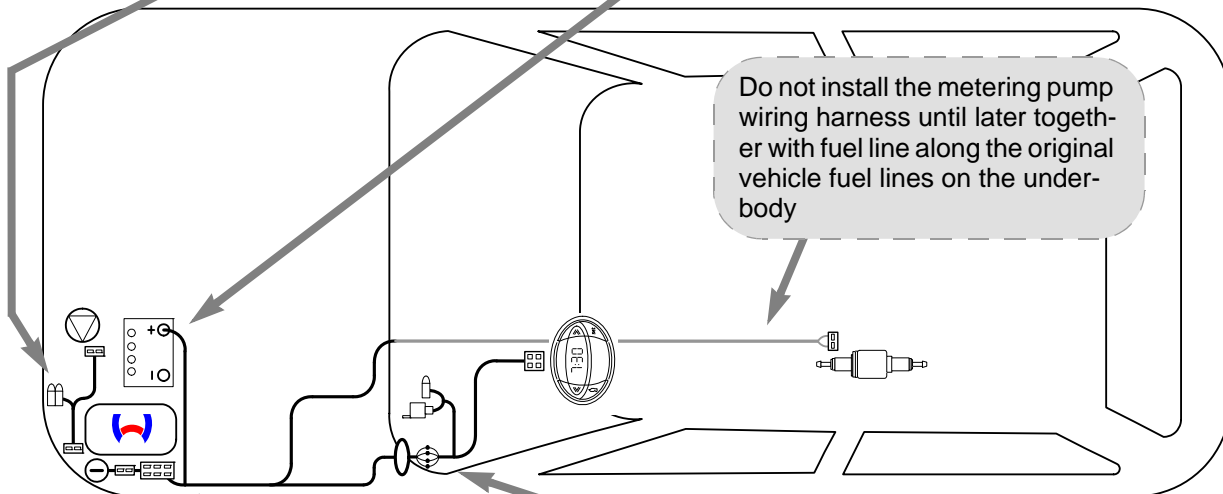
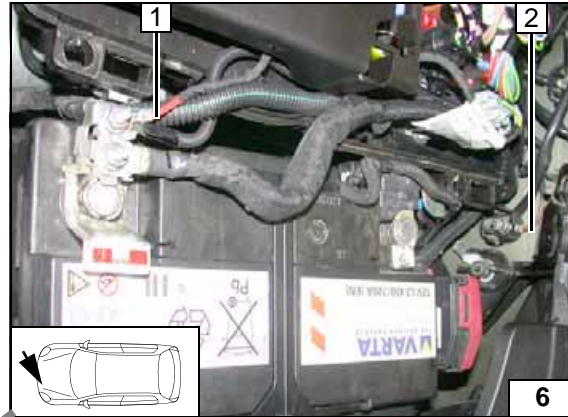

Wiring harness routing diagram

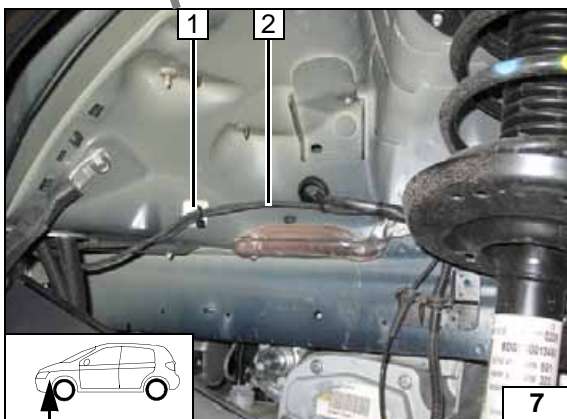

Wiring harness routing

- 1 Adhesive base, cable tie
- 2 Wiring harnesses of heater and heater control

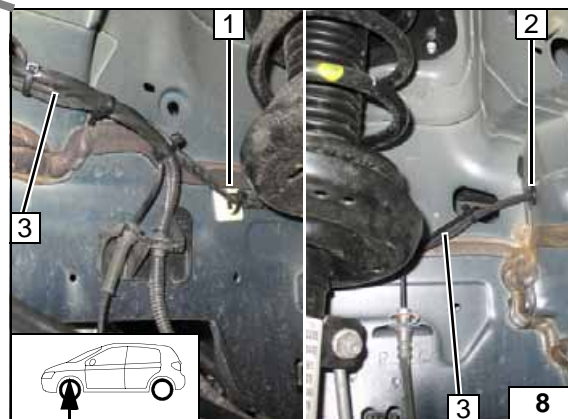

Wiring harness pass through of passenger compartment

- 1 Adhesive base, cable tie
- 2 Protective rubber plug (punch hole)
- 3 Wiring harnesses of heater and heater control



Fan Controller

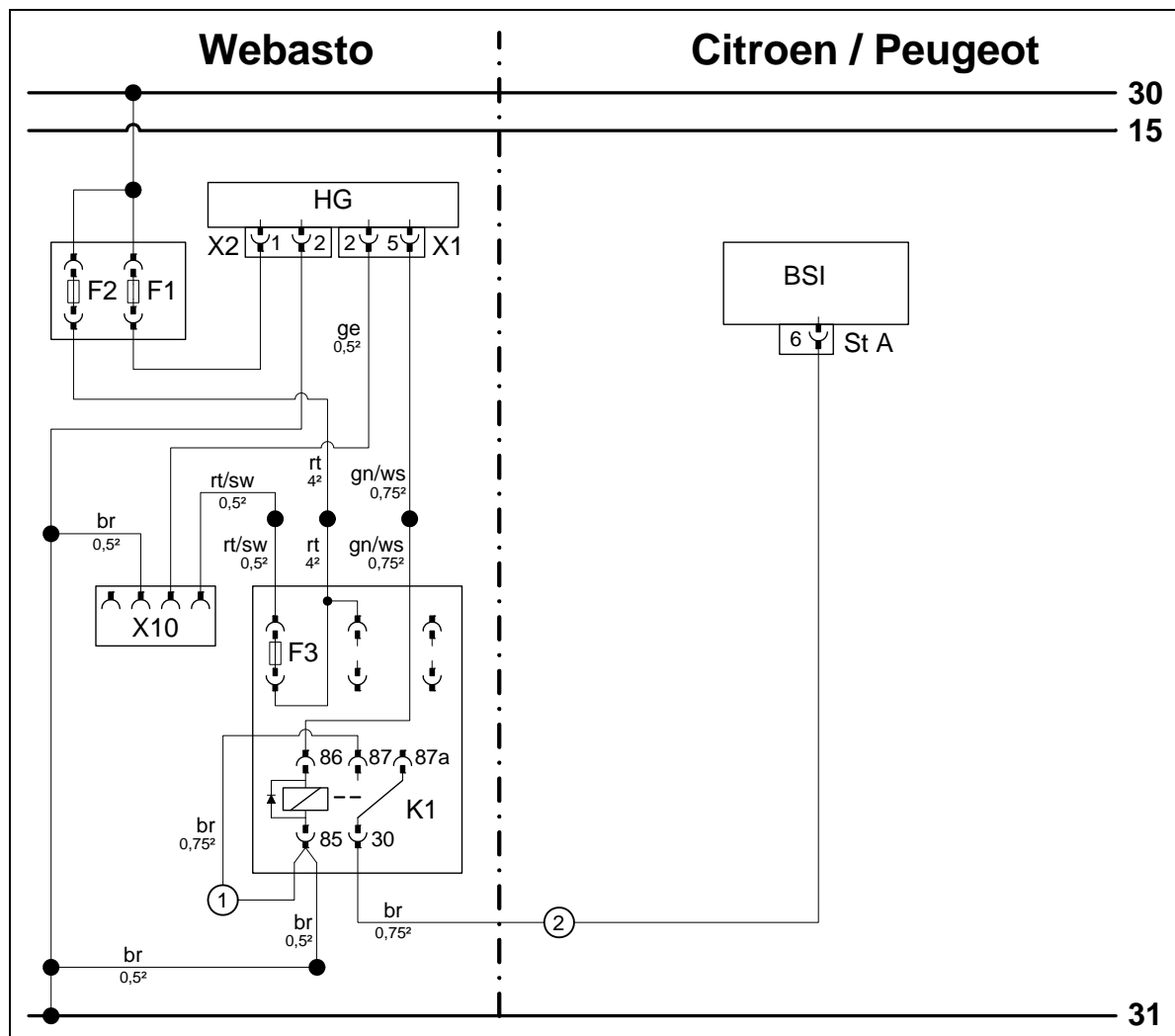

Wiring diagram

Webasto components		Components vehicle		Colours and symbols	
HG	TT-Evo heater	BSI	Central electrical box for passenger compartment	gn	green
X1	6-pin heater connector			ws	white
X2	2-pin heater connector	St A	20-pin connector BSI	rt	red
X10	4-pin connector of heater control			br	brown
K1	Fan relay			sw	black
F1	20A fuse			ge	yellow
F2	30A fuse			Cable and connector colours may vary.	
F3	1A fuse				

Legend

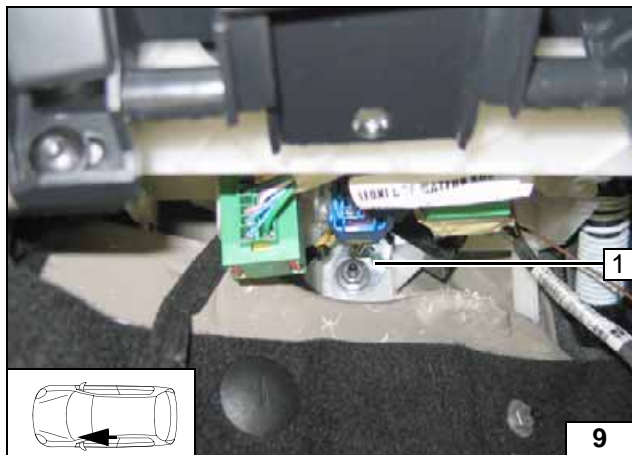

1 Angle bracket, original vehicle stud bolt, flanged nut

Installing fuse holder of passenger compartment

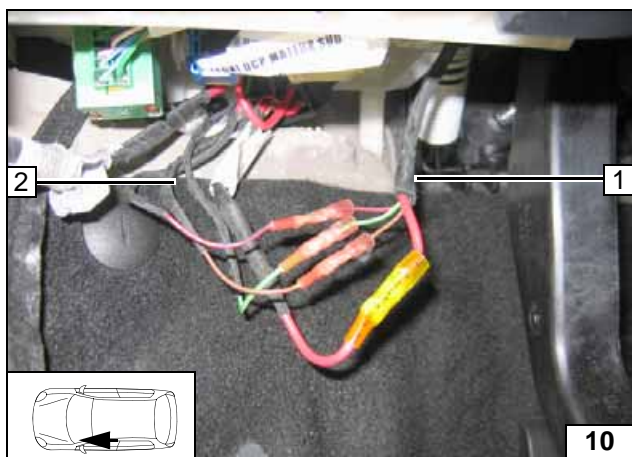

Connect wiring harness of passenger compartment fuse holder 1 to wiring harness of heater 2 according to wiring diagram, in such a way that the wires of the same colour are connected to each other.



Connecting wiring harnesses

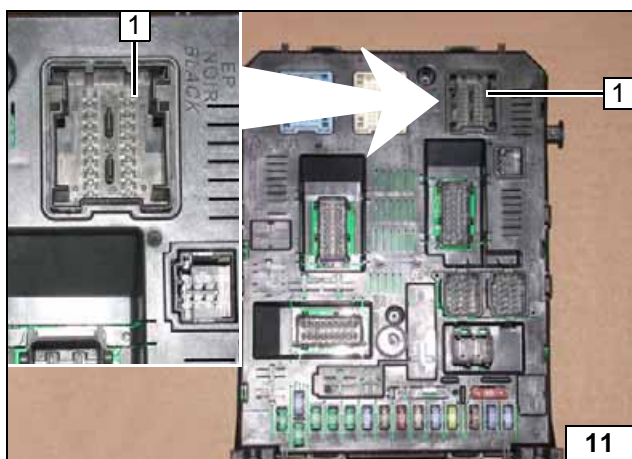

View of BSI.

1 Socket for 2-piece connector. 40-pin



Detaching BSI and routing downward

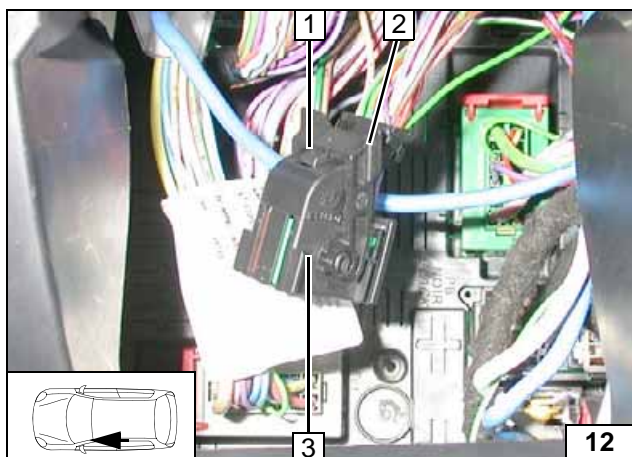

Press in locking lug 1 and fold down bar 2 .

3 2-piece connector



Pulling connector off BSI and removing

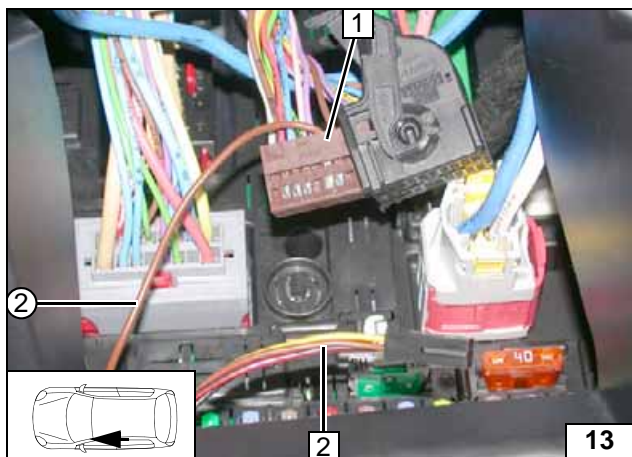

Connection on 20-pin connector **1** from BSI (connector colour may vary). Insert microtimer from brown (br) wire **2** in PIN 6. Remove any existing wires on pin 6 and insulate. Route wiring harness of digital timer **2** upward to installation location of digital timer. Produce connections as shown in wiring diagram.



**Connec-
tion of BSI**

Digital Timer

- 1 Digital timer



**Installing
digital timer**

Remote option (Telestart)

Mount connector (6-pin) from adapter wiring harness on receiver **2**.

- 1 Double-sided adhesive tape



**Installing
receiver**

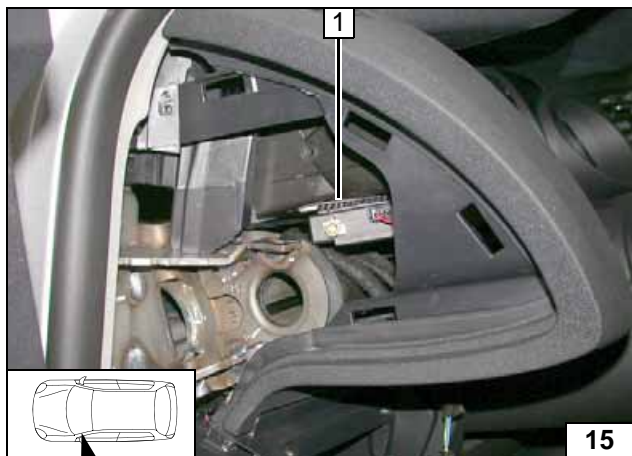

- 1 Antenna

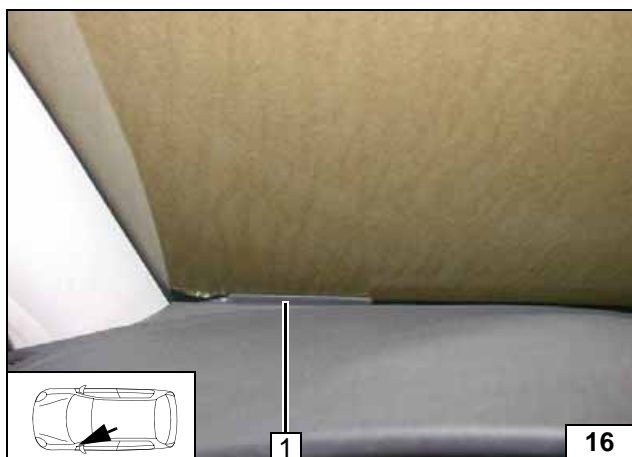

**Installing
antenna**

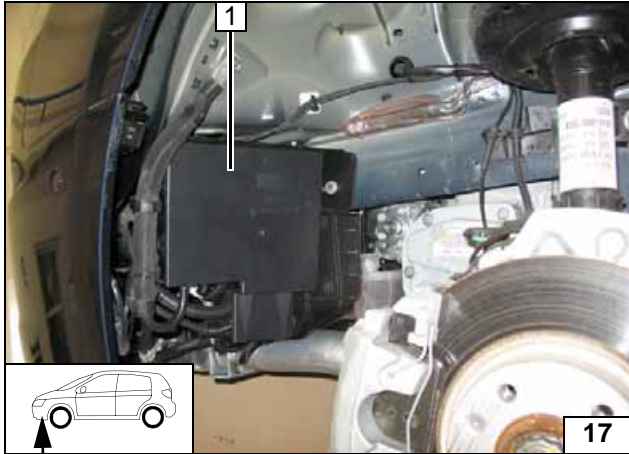
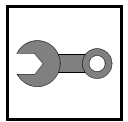

Preparing Installation Location

Prior to loosening capacitor unit 1, discharge Ultra-Capacity (UCAP) in accordance with manufacturer's instructions and using special tool S-1288.



Loosening capacitor unit

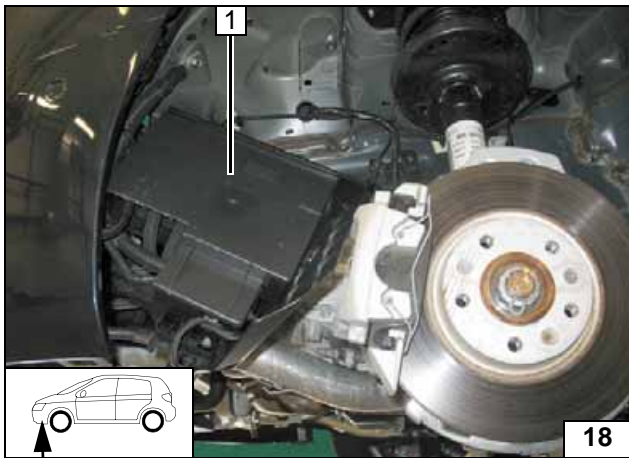

Loosen capacitor unit 1 and secure against falling using suitable means.



Securing capacitor unit

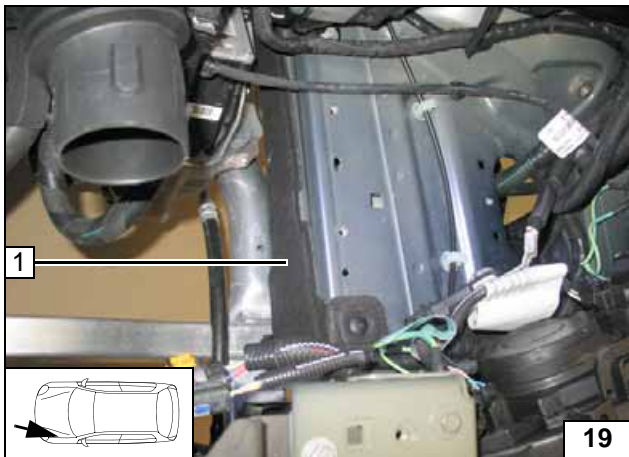

1 Insulation mat

Removing insulation mat

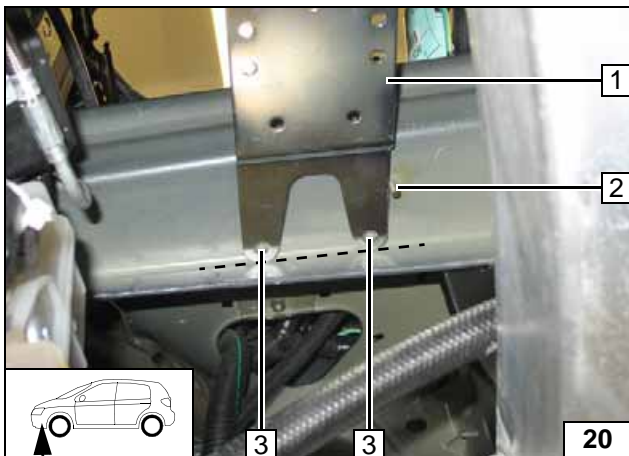

Place bracket 1 on original vehicle stud bolt 2 and edge of frame side member (see marking).

3 Copy hole pattern [2x]



Copying hole pattern

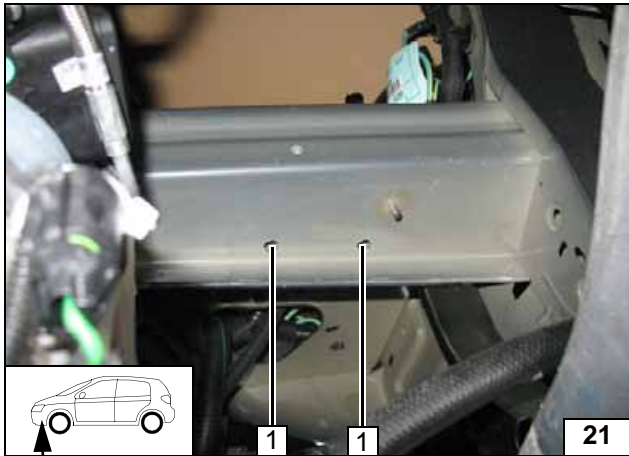

1 9.1mm dia. hole [2x] for bracket

Hole in frame side member

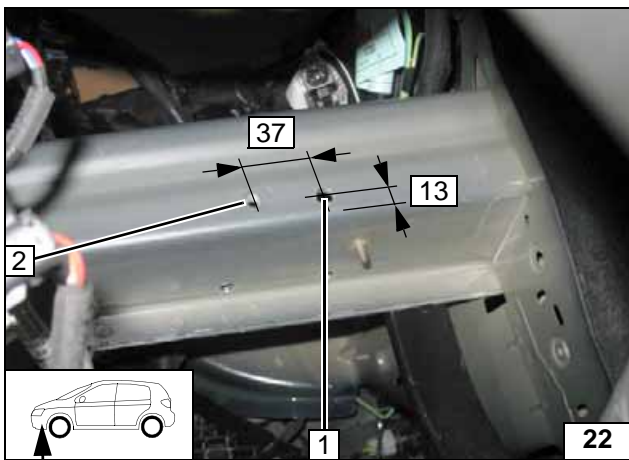

1 9.1 mm dia. hole for angle bracket
2 Original vehicle threaded hole

Hole in frame side member

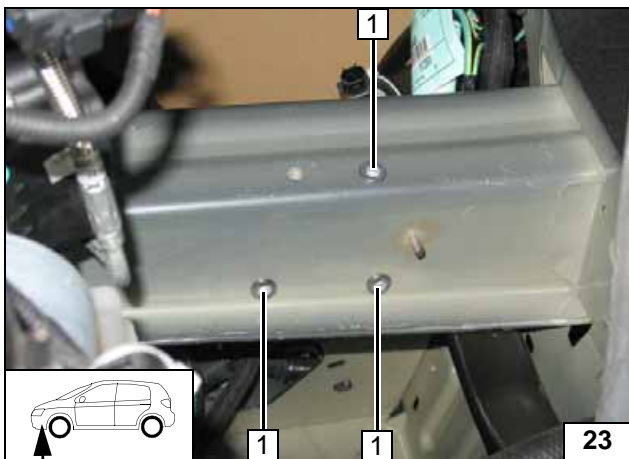

1 Rivet nut (steel) [3x]

Installing rivet nut

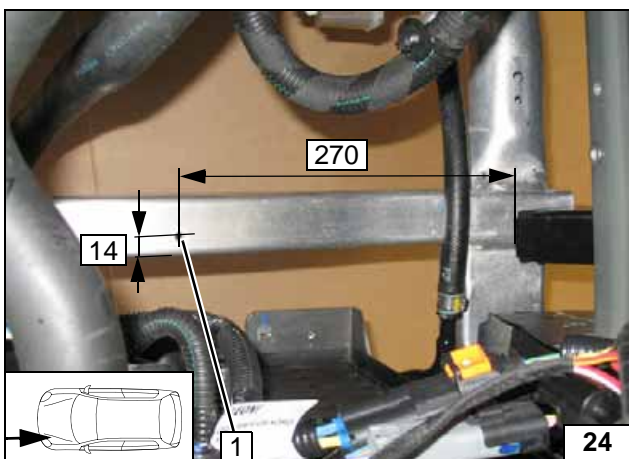

1 9.1mm dia. hole; rivet nut (aluminium) for circulating pump

Installing rivet nut

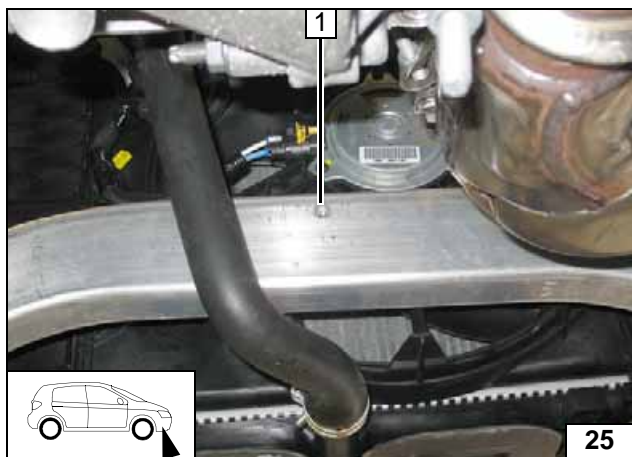

1 Drill out 9.1mm dia. hole; rivet nut (aluminium) for exhaust pipe

Installing rivet nut

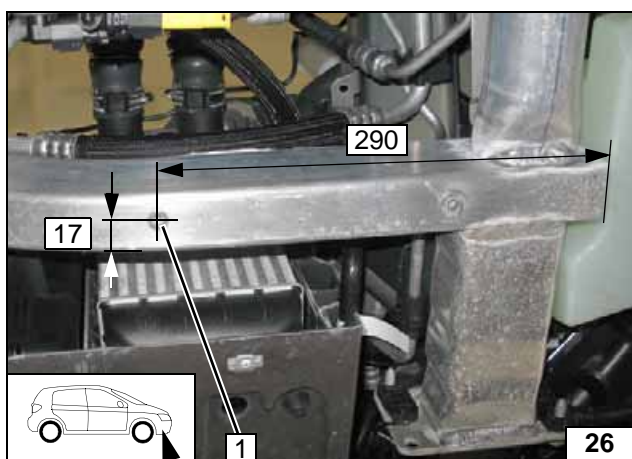

1 9.1mm dia. hole; rivet nut (aluminium) for exhaust silencer

Installing rivet nut

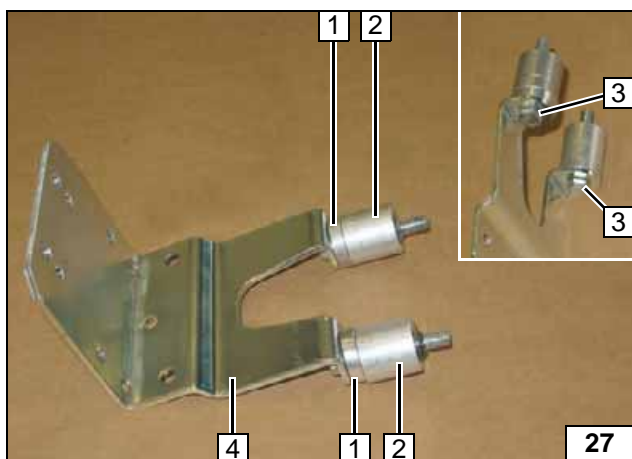

Prepare bracket 4 in accordance with the template.

- 1 5mm shim [2x]
- 2 20mm shim [2x]
- 3 M6x40 bolt, spring lockwasher, pin lock [2x each]

Preparing bracket

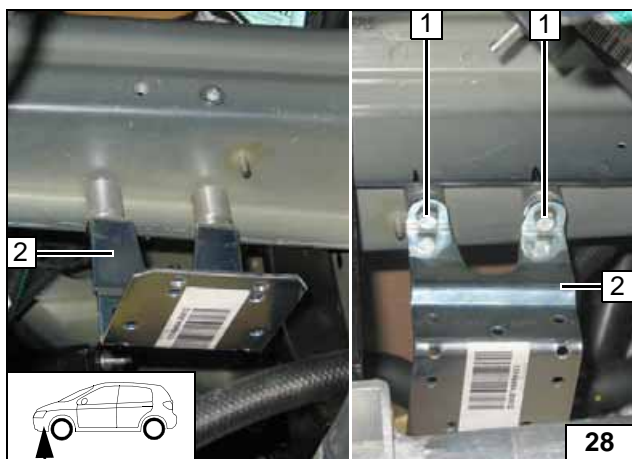

- 1 Loosely mount M6x40 bolt
- 2 Bracket

Installing bracket loosely

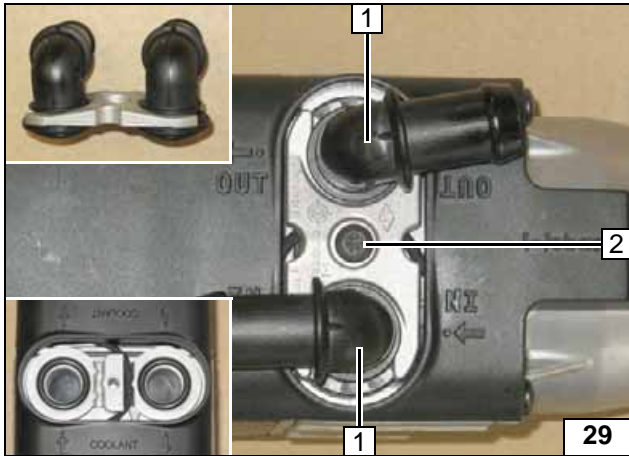
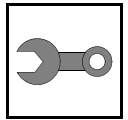

Preparing Heater

- 1 Water connection piece, sealing ring [2x each]
- 2 5x15 self-tapping bolt, retaining plate of water connection pieces



Installing water connection pieces

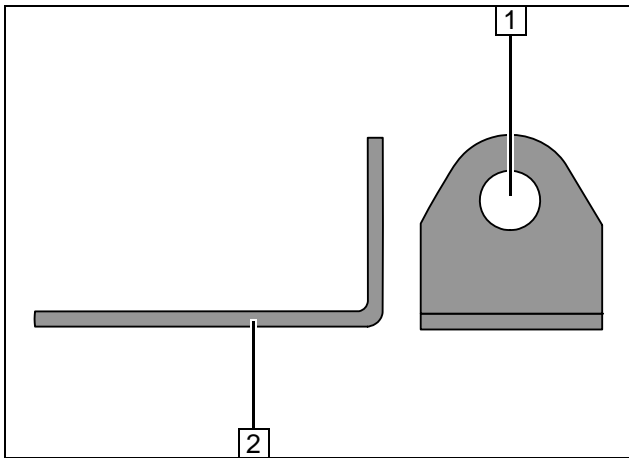

- 1 Drill out 8 mm dia. hole
- 2 Angle bracket [2x]

Drilling out two angle brackets

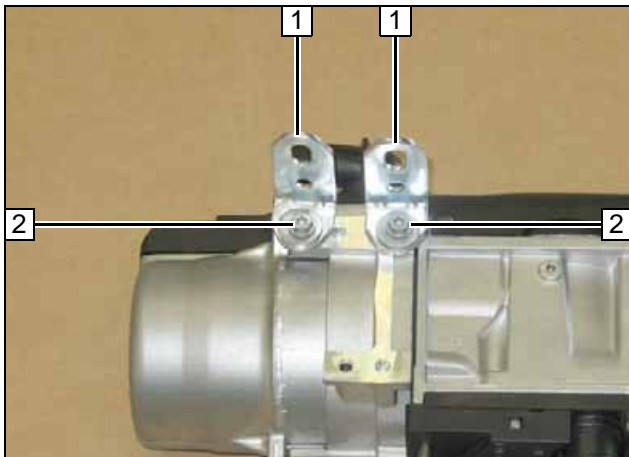

- 1 Loosely mount angle bracket [2x]
- 2 5x13 self-tapping bolts, large diameter washer [2x each]

Loosely mounting angle bracket

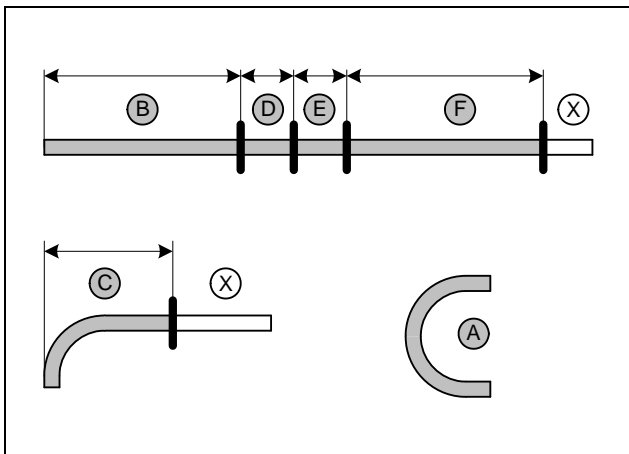

Discard section X.

Hose A = 18mm dia., 180° moulded hose
 Hose C = 18mm dia., 90° moulded hose, shorten

- B = 750
- C = 230
- D = 55
- E = 60
- F = 630



Cutting hoses to length

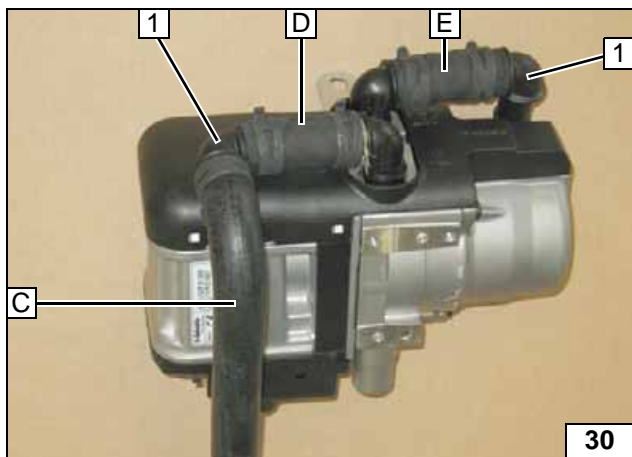

All spring clips = 25 mm dia.

- 1 90° connecting pipe [2x]

Premounting hoses

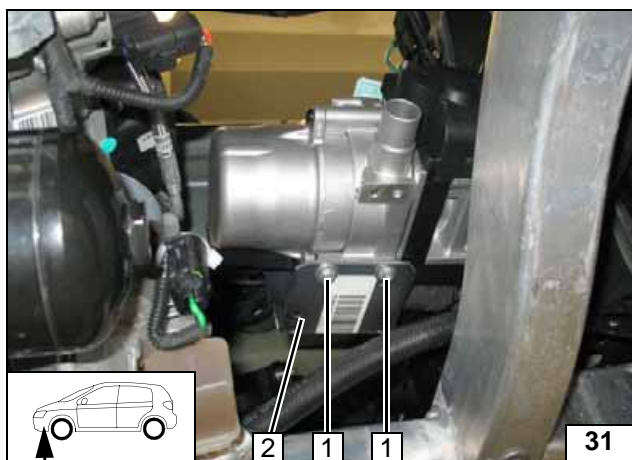

Installing Heater

- 1 5x13 self-tapping bolts, washer [2x each]
- 2 Bracket

Installing heater

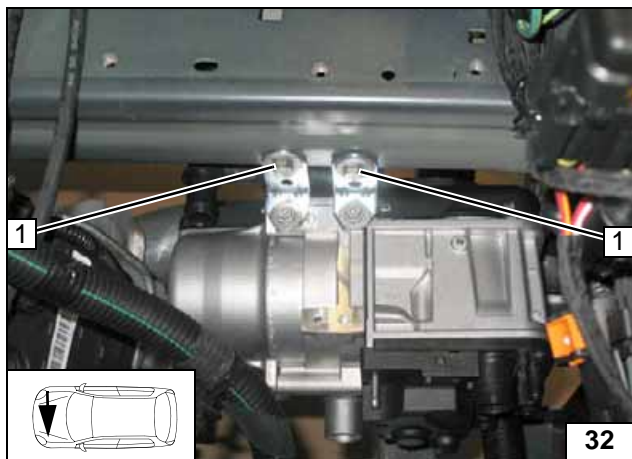

- 1 Loosely mount M6x20 bolt, large diameter washer [2x each]

Installing heater

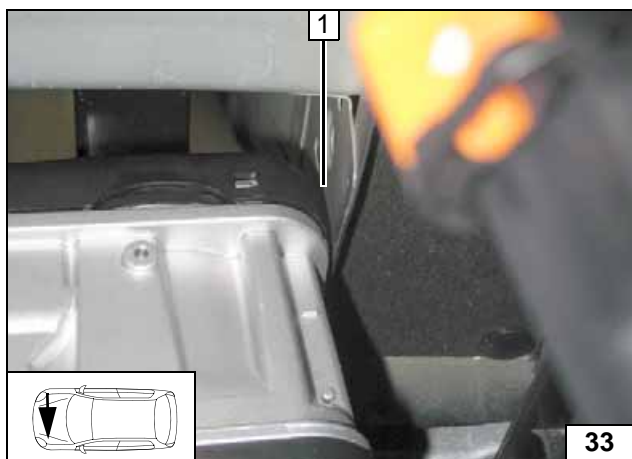

Align heater. Ensure sufficient distance at position 1. Tighten all loose screw connections.



Installing heater

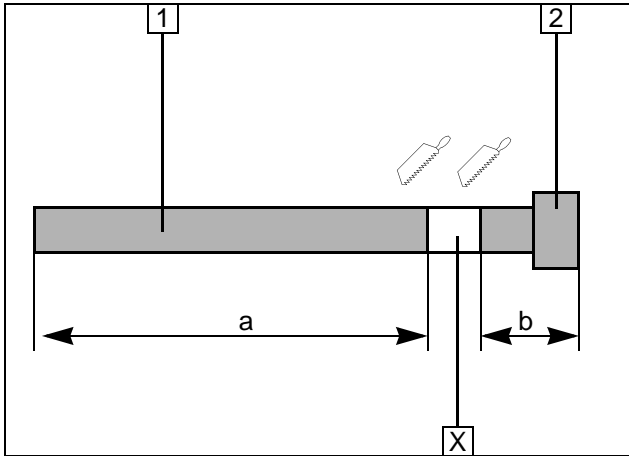
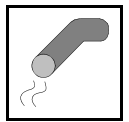

Exhaust Gas

Discard section X.

- 1 Exhaust pipe
a = 580
- 2 Exhaust end section
b = 85

Preparing exhaust pipe

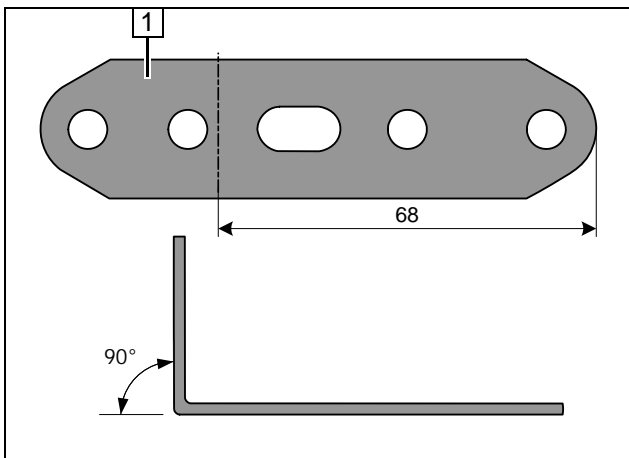

- 1 Perforated bracket

Angling down perforated bracket

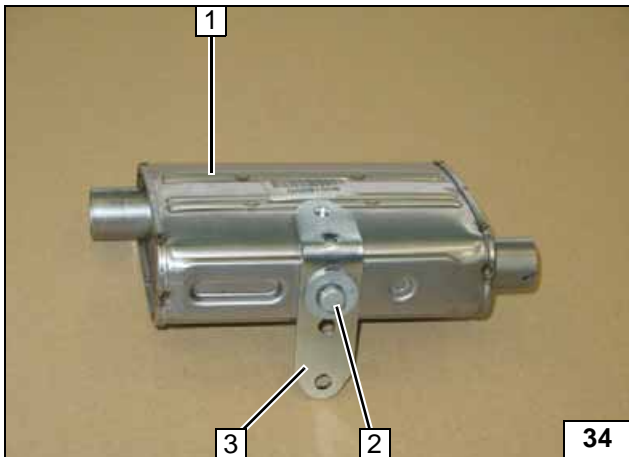

- 1 Silencer
- 2 M6x16 bolt, spring lockwasher, large diameter washer
- 3 Perforated bracket

Premounting silencer

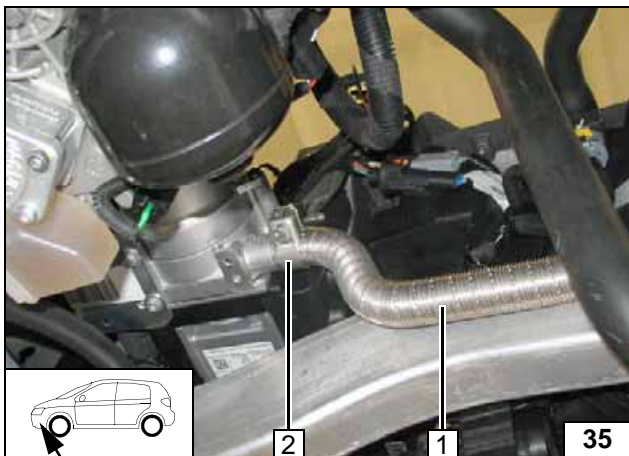

- 1 Exhaust pipe
- 2 Hose clamp

Installing exhaust pipe

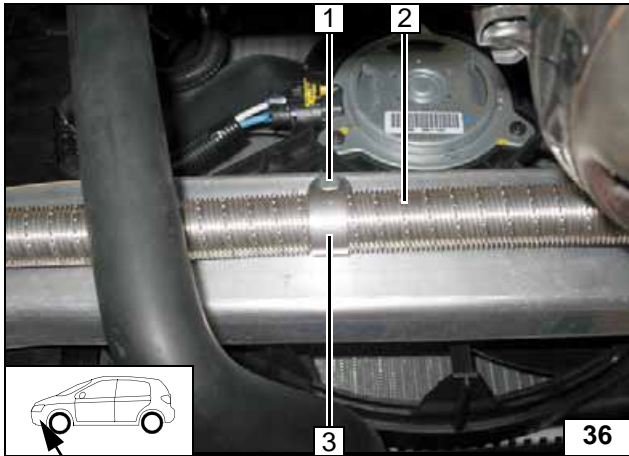
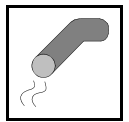

- 1 M6x25 bolt, 5mm shim
- 2 P-clamp
- 3 Exhaust pipe

Fastening exhaust pipe

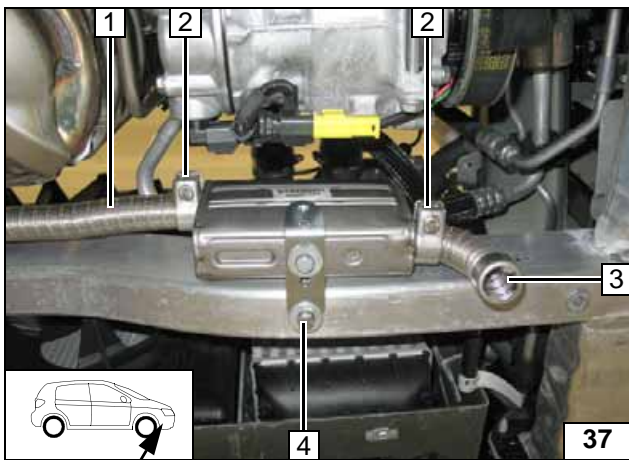

Ensure sufficient distance to neighbouring components; correct if necessary.

- 1 Exhaust pipe
- 2 Hose clamp [2x]
- 3 Exhaust end section
- 4 M6x20 bolt, spring lockwasher, large diameter washer

Installing silencer and end section

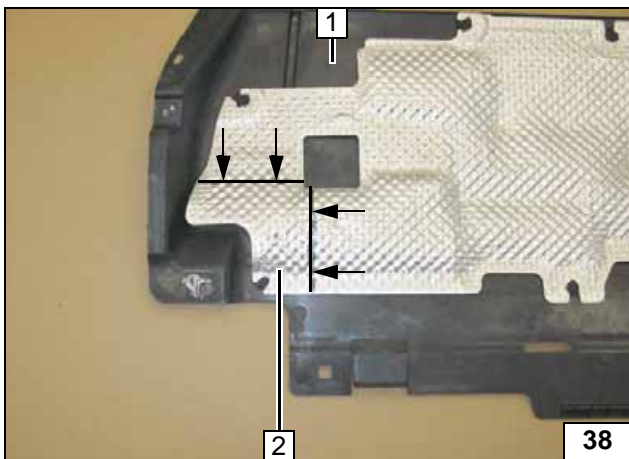

Cut out insulation in the area of the marking.

- 1 Underride protection
- 2 Discard section

Cutting out insulation of under-ride protection

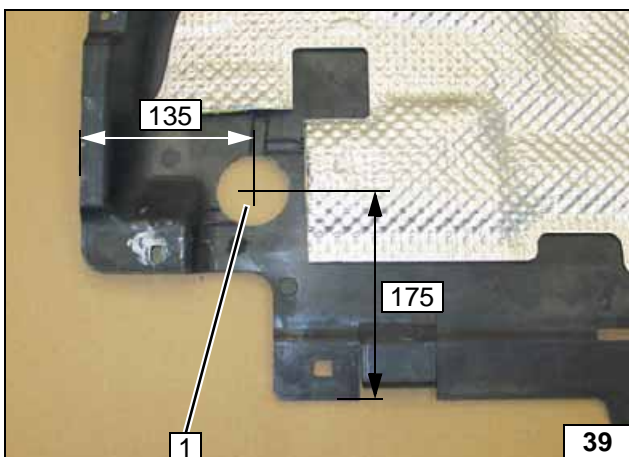

- 1 60 mm dia. hole

Hole in underride protection





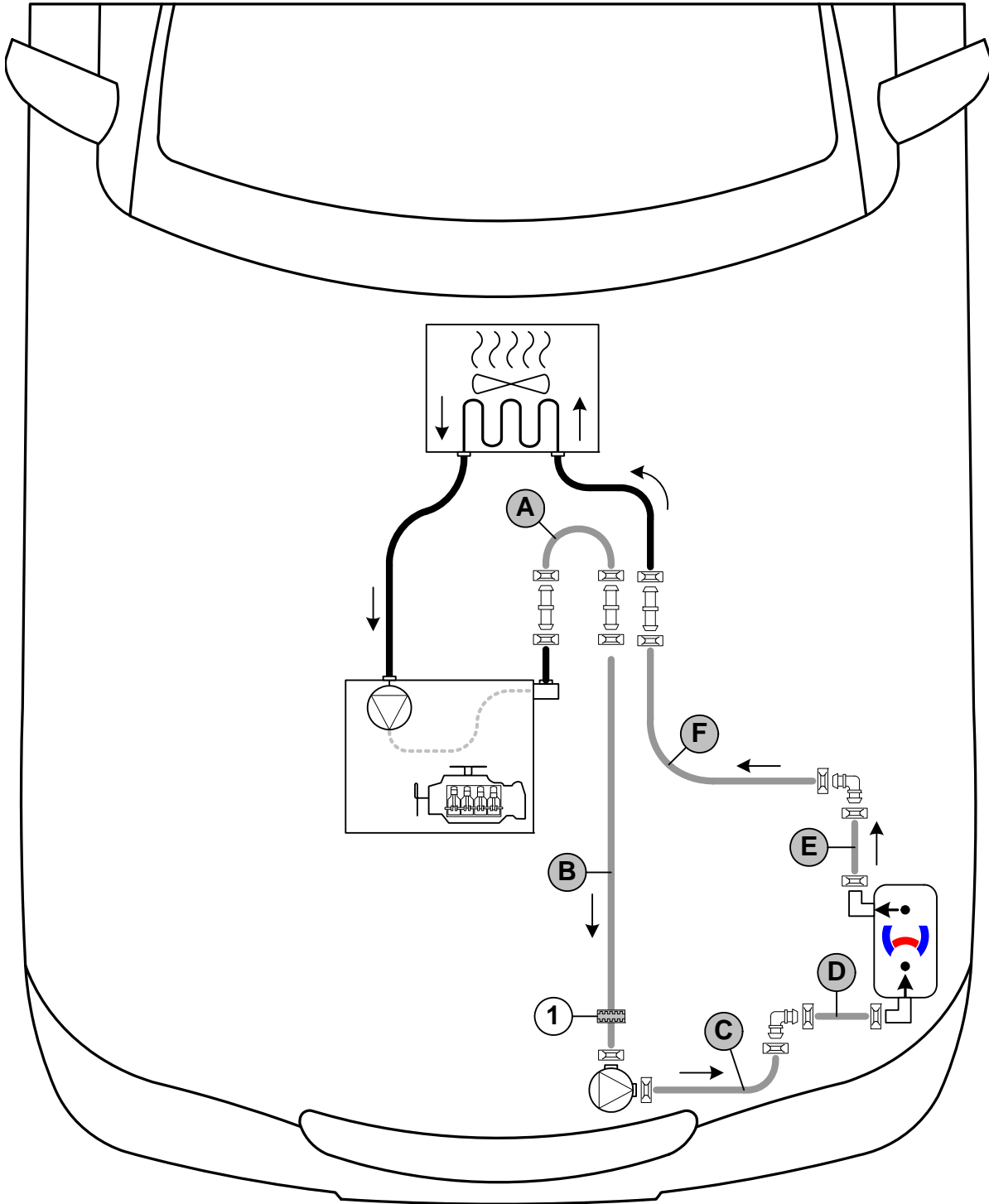

Coolant Circuit

WARNING!

Any coolant running off should be collected in an appropriate container. Route hoses so that they are kink-free. Unless specified otherwise, always fasten using cable ties. Position clamps so that other hoses cannot be damaged. When installing the hoses, the heater must be filled with coolant. The connection should be "inline" based on the following diagram:



Hose routing diagram

All spring clips  = 25 mm dia.
 1 = Black (sw) rubber isolator .
 All connecting pipes  and  = 18x18mm dia.



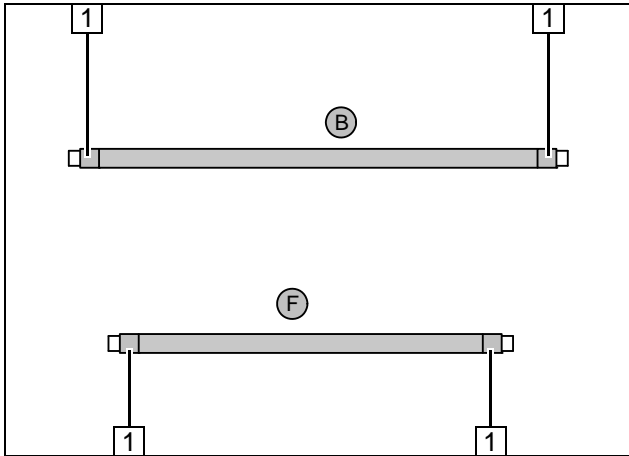

Push braided protection hoses onto hose **B** and **F** and cut to length. Cut heat shrink plastic tubing to length.

- 1 50 mm long heat shrink plastic tubing [4x]

Preparing hoses

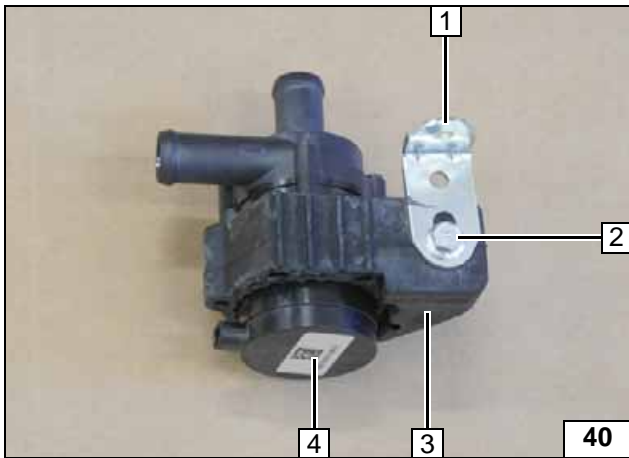

- 1 Angle bracket
- 2 M6x25 bolt, flanged nut
- 3 Circulating pump mounting
- 4 Circulating pump

Premounting circulating pump

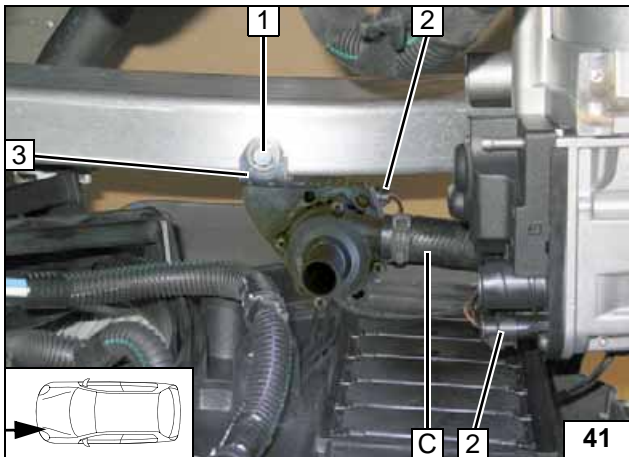

- 1 M6x20 bolt, large diameter washer
- 2 Install wiring harness of circulating pump [2x]
- 3 Angle bracket

Mounting circulating pump

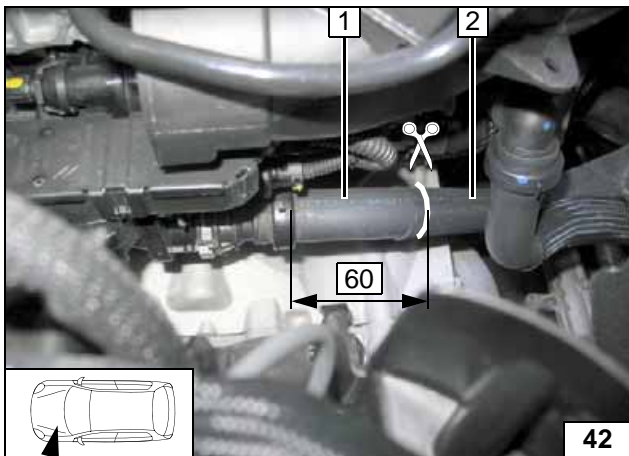

Cut off hose on engine outlet / heat exchanger inlet at the marking. Remove braided protection hose in area of cutting point.

- 1 Hose section of engine outlet
- 2 Hose section of heat exchanger inlet



Cutting point

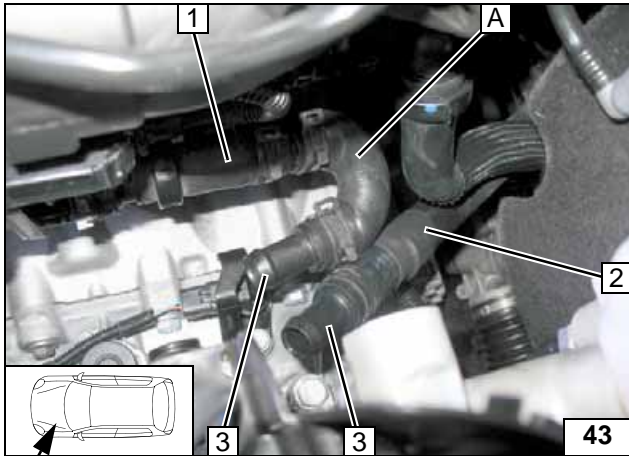

Premount connecting pipes 3 [2x].

- 1 Hose of engine outlet
- 2 Hose of heat exchanger inlet

Preparing connection

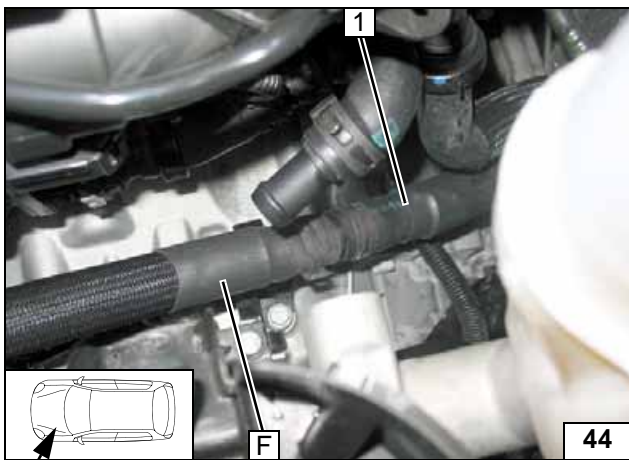

- 1 Hose of heat exchanger inlet

Connecting heat exchanger inlet

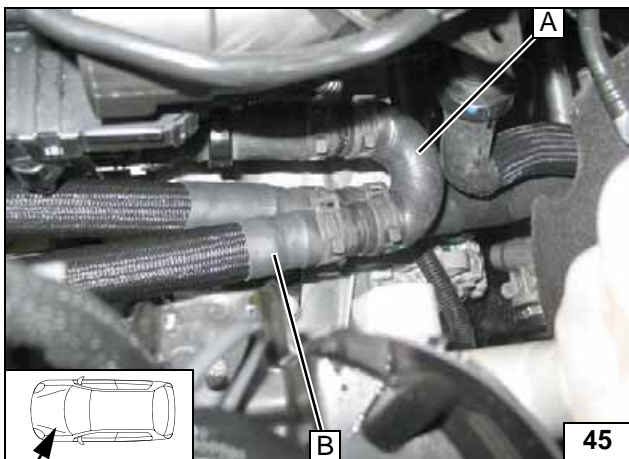

Connecting engine outlet

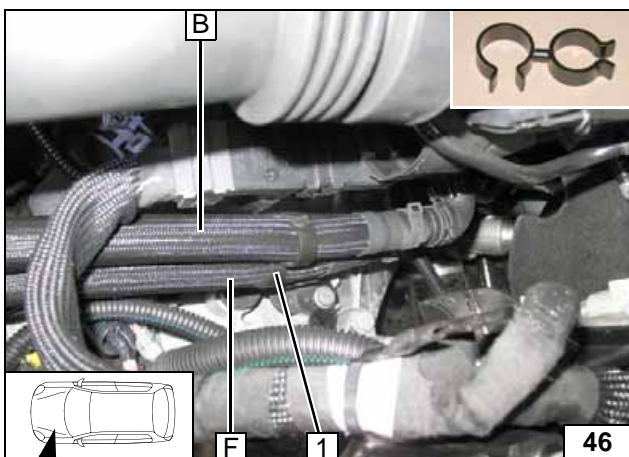

- 1 Hose bracket

Mounting hose bracket

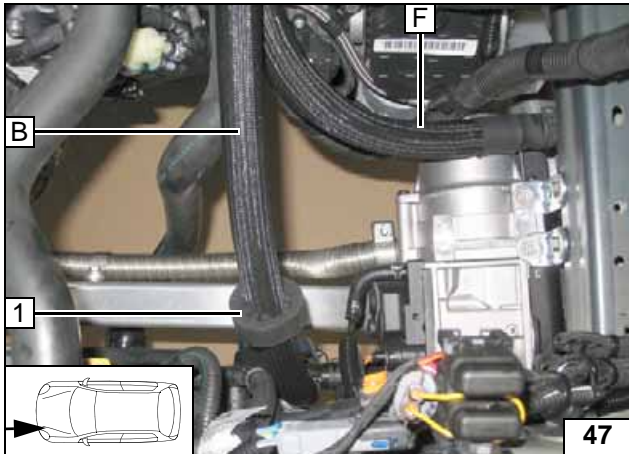

Push black (sw) rubber isolator **1** onto hose **B**. Connect hose **B** to circulating pump. Connect hose **F** with hose **E**.



**Connect-
ing heater**



1 Hose bracket

**Mounting
hose
bracket**



Align hoses. Ensure sufficient distance to neighbouring components; correct if necessary.

1 Hose bracket [2x] on hose **F** (hidden)



**Mounting
hose
bracket**

Citroen C5

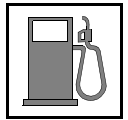

Fuel

CAUTION!

Open the vehicle's fuel tank cap, ventilate the tank and then re-close the tank lock.

Catch any fuel running off in an appropriate container.

Install fuel line and metering pump wiring harness so that they are protected against stone impact. Unless specified otherwise, always fasten using cable ties.
Mount the fuel line and wiring harness with rub protection on sharp edges.

WARNING!

The fuel line and wiring harness are routed to the metering pump as shown in the wiring harness routing diagram.

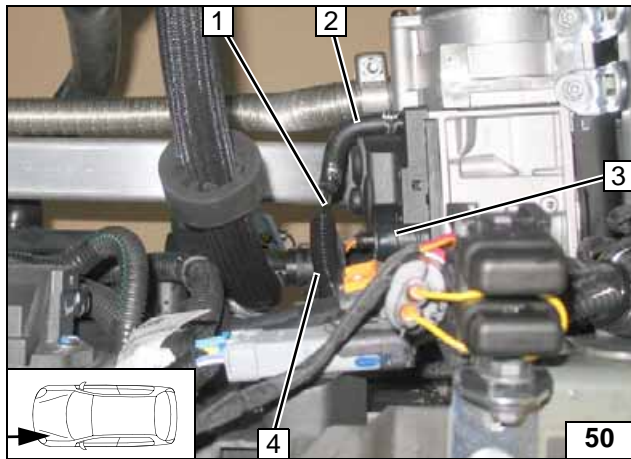

Pull fuel line **1** and wiring harness of metering pump into 10mm dia. corrugated tube **4** .

- 2** 90° moulded hose, 10mm dia. clamp [2x]
- 3** Install wiring harness of heater [2x]



Connect-
ing heater

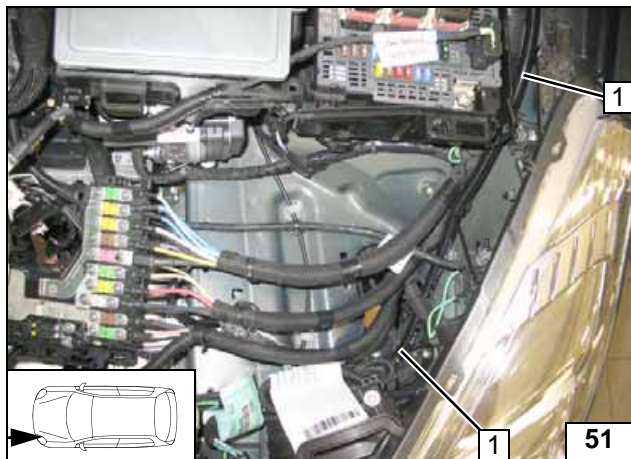

Route fuel line and wiring harness of metering pump in 10mm dia. corrugated tube **1** .



Routing
lines

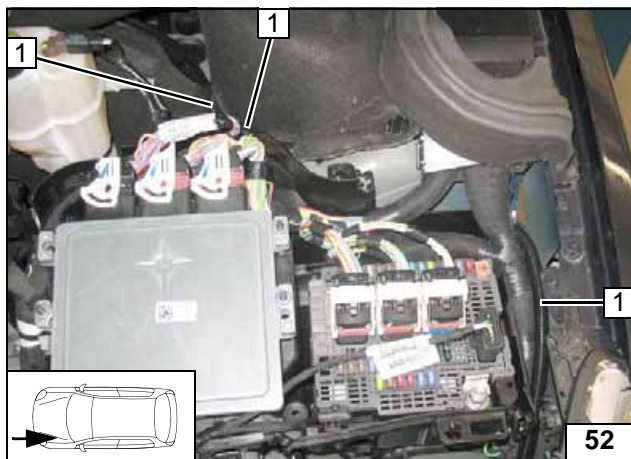

Route fuel line and wiring harness of metering pump in 10mm dia. corrugated tube **1** behind the fuse and relay carrier to the firewall and on to the underbody .



Routing
lines

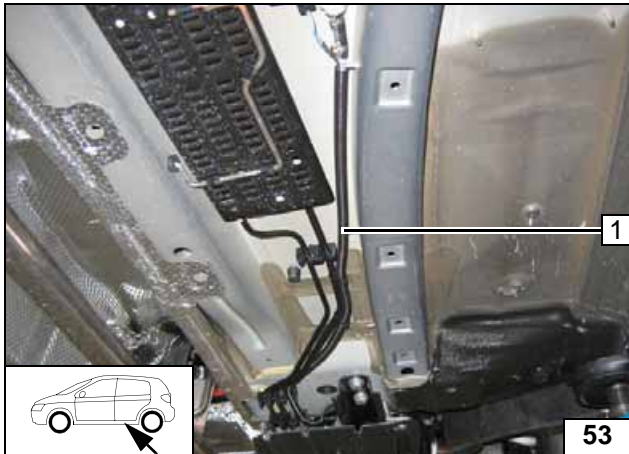
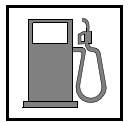

- 1 Fuel line and wiring harness of metering pump in corrugated tube



Routing lines

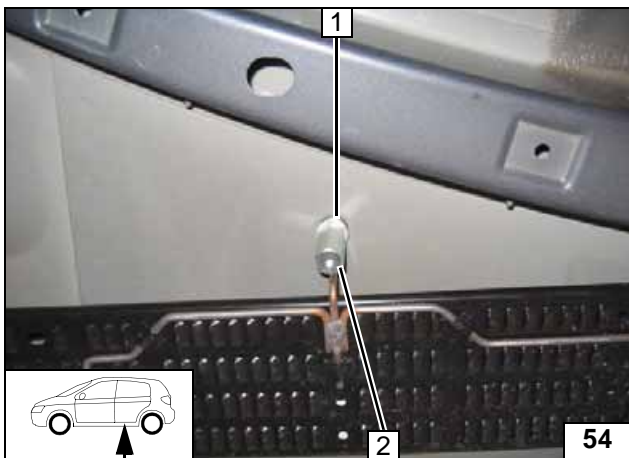

Remove original vehicle nut at position 1 and discard.

- 2 Large diameter washer, 30mm spacer nut, original vehicle stud bolt



Mounting metering pump

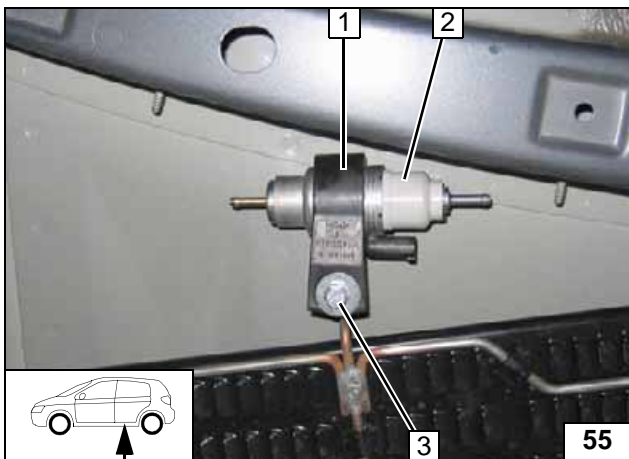

- 1 Mounting of metering pump
- 2 Metering pump
- 3 M6x25 bolt, angle support, large diameter washer



Mounting metering pump

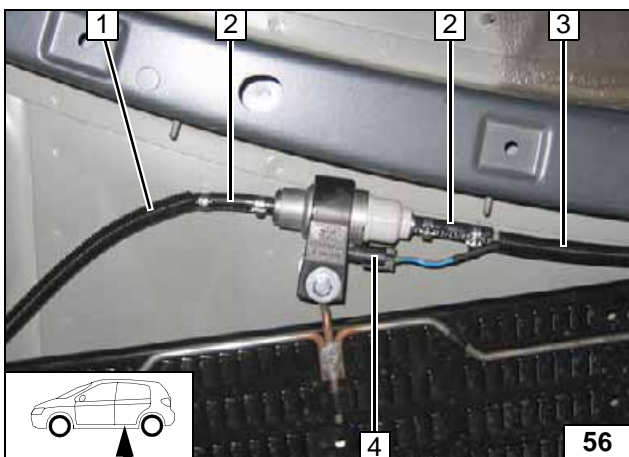

Check the position of the components; adjust if necessary. Check that they have freedom of movement.

- 1 Fuel line of fuel standpipe in corrugated tube
- 2 Hose section [2x], 10mm dia. clamp [4x]
- 3 Fuel line of heater, wiring harness of metering pump in corrugated tube
- 4 Wiring harness of metering pump, connector mounted



Connecting metering pump

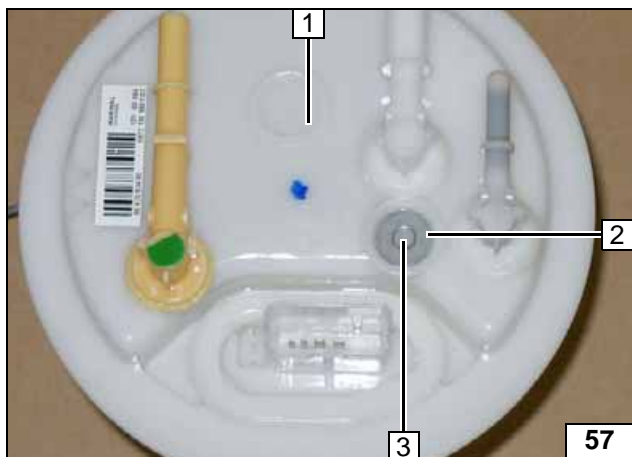

Remove fuel-tank sending unit **1** in accordance with the manufacturer's instructions. Position large diameter washer with outer dia. $d_a = 14.6$ **2** centrally in perforation.

3 Copy hole pattern, 6mm dia. hole



Fuel extraction

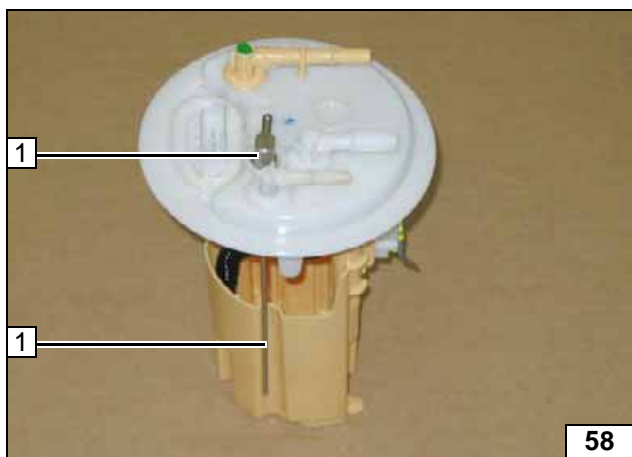

Shape fuel standpipe **1** according to template and cut it to length.



Installing fuel standpipe

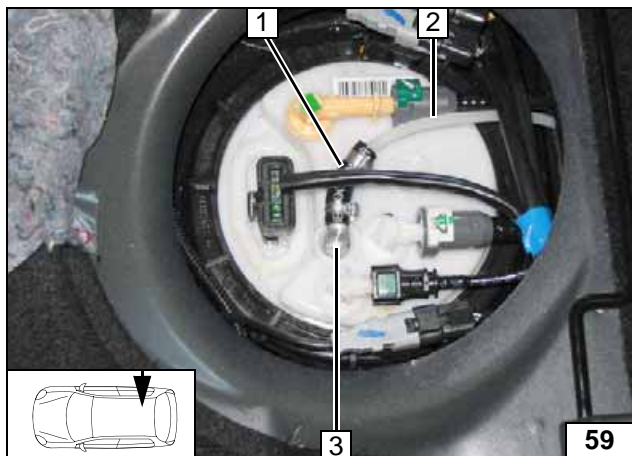

Check the position of the components; adjust if necessary. Check that they have freedom of movement. Install fuel-tank sending unit according to manufacturer's instructions.



Connecting fuel line

- 1** Hose section, 10mm dia. clamp [2x]
- 2** Fuel line
- 3** Fuel standpipe

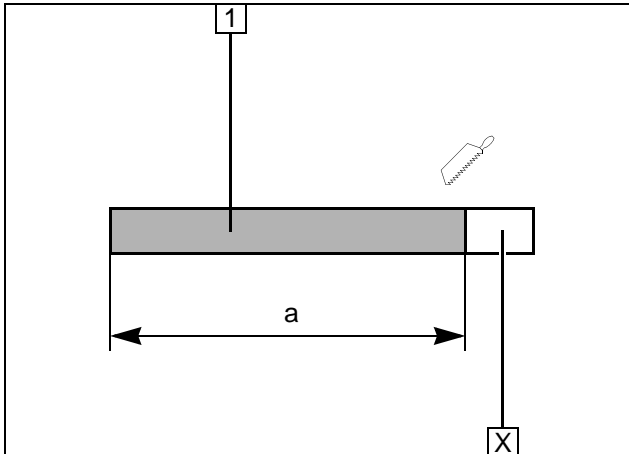
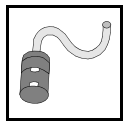

Combustion Air

Discard section X.

- 1 Combustion air pipe
a = 345

Cutting combustion air pipe to length

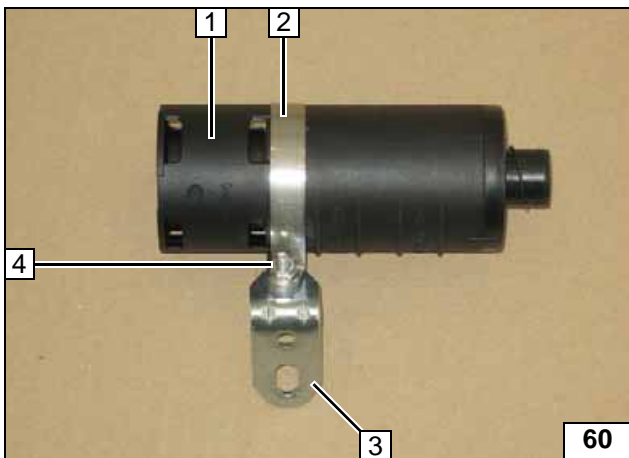

- 1 Silencer
- 2 51mm dia. clamp
- 3 Angle bracket
- 4 M5x16 bolt, large diameter washer, flanged nut

Premounting silencer

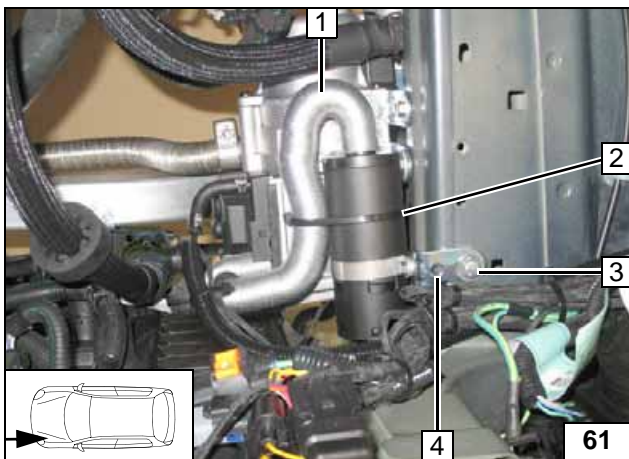

- 1 Combustion air pipe
- 2 Cable tie
- 3 M6x20 bolt, large diameter washer, existing threaded hole
- 4 Angle bracket

Installing combustion air pipe and silencer

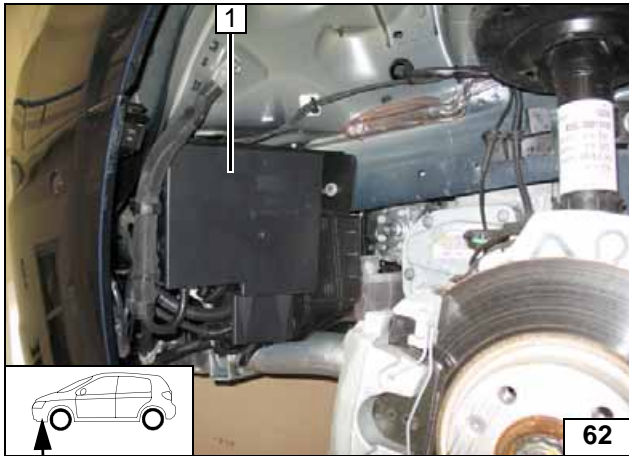

Final Work

Install capacitor unit 1.



Installing capacitor unit

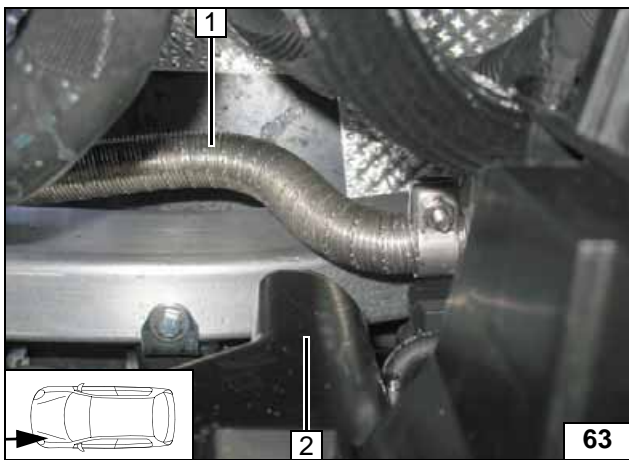

Install resonator 2. Ensure sufficient distance between exhaust pipe 1 and resonator 2, maintain at least 20mm!



Checking distance

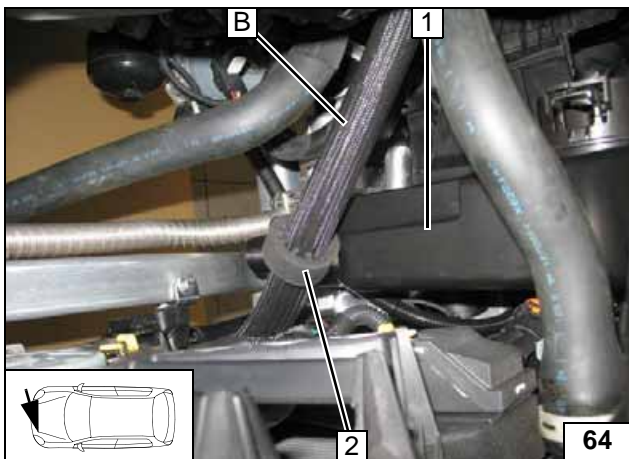

Align black (sw) rubber isolator 2 to resonator 1 .



Aligning rubber isolator



WARNING!

Mount removed parts in reverse order. Check all hoses, clamps and all electrical connections for firm seating. Insulate all loose wires and tie back.

Only use manufacturer-approved coolant. Spray the heater components with anti-corrosion wax (Tectyl 100K, Order No. 111329).



Encode BSI to use the parking heater according to manufacturer's instructions using Diag-Box.



- Connect the battery.
- Fill and bleed the coolant circuit according to the vehicle manufacturer's specifications.
- Adjust digital timer, teach telestart transmitter.
- No settings needed on the A/C control panel
- Place the "Switch off parking heater before refuelling" signboard in the area of the filler neck.
- For initial startup and function check, please see installation instructions.

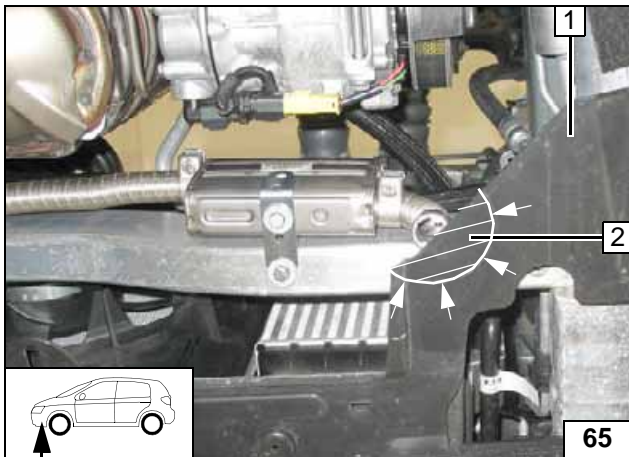

Install front left under-ride protection 1 and cut out in the area of the marking.

2 Discard section

Cutting out under-ride protection

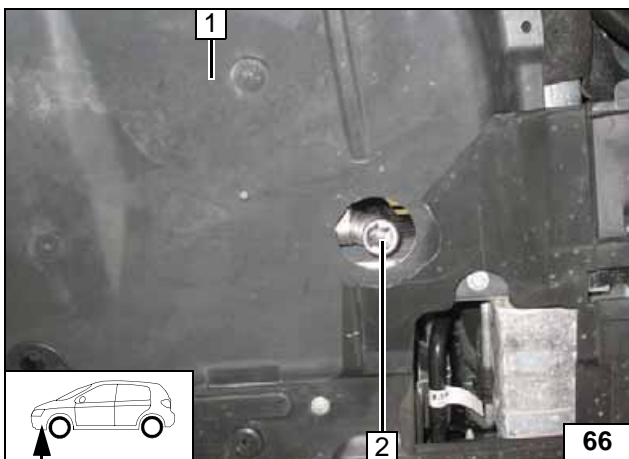

Install under-ride protection 1. Align exhaust end section 2 centrally in the hole of under-ride protection 1.

Aligning exhaust end section

Webasto Thermo & Comfort SE
 Postfach 1410
 82199 Gilching
 Germany
 Internet: www.webasto.com
 Technical Extranet:
<http://dealers.webasto.com>

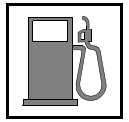

Template for Fuel Standpipe

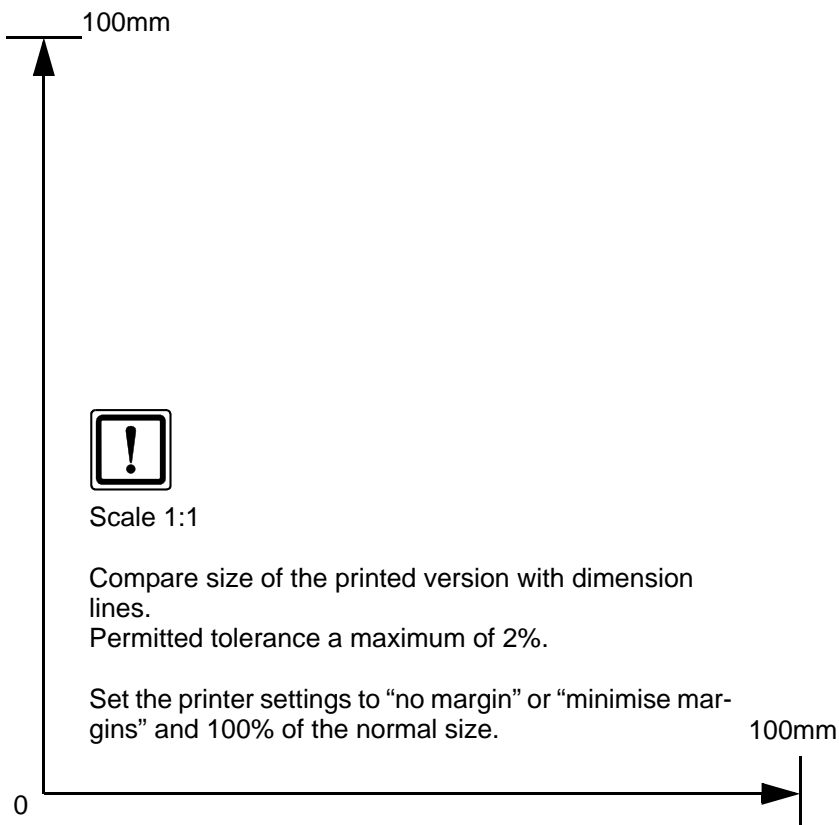

Scale 1:1

Compare size of the printed version with dimension lines.
Permitted tolerance a maximum of 2%.

Set the printer settings to "no margin" or "minimise margins" and 100% of the normal size.

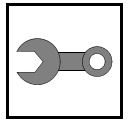

Template for Bracket

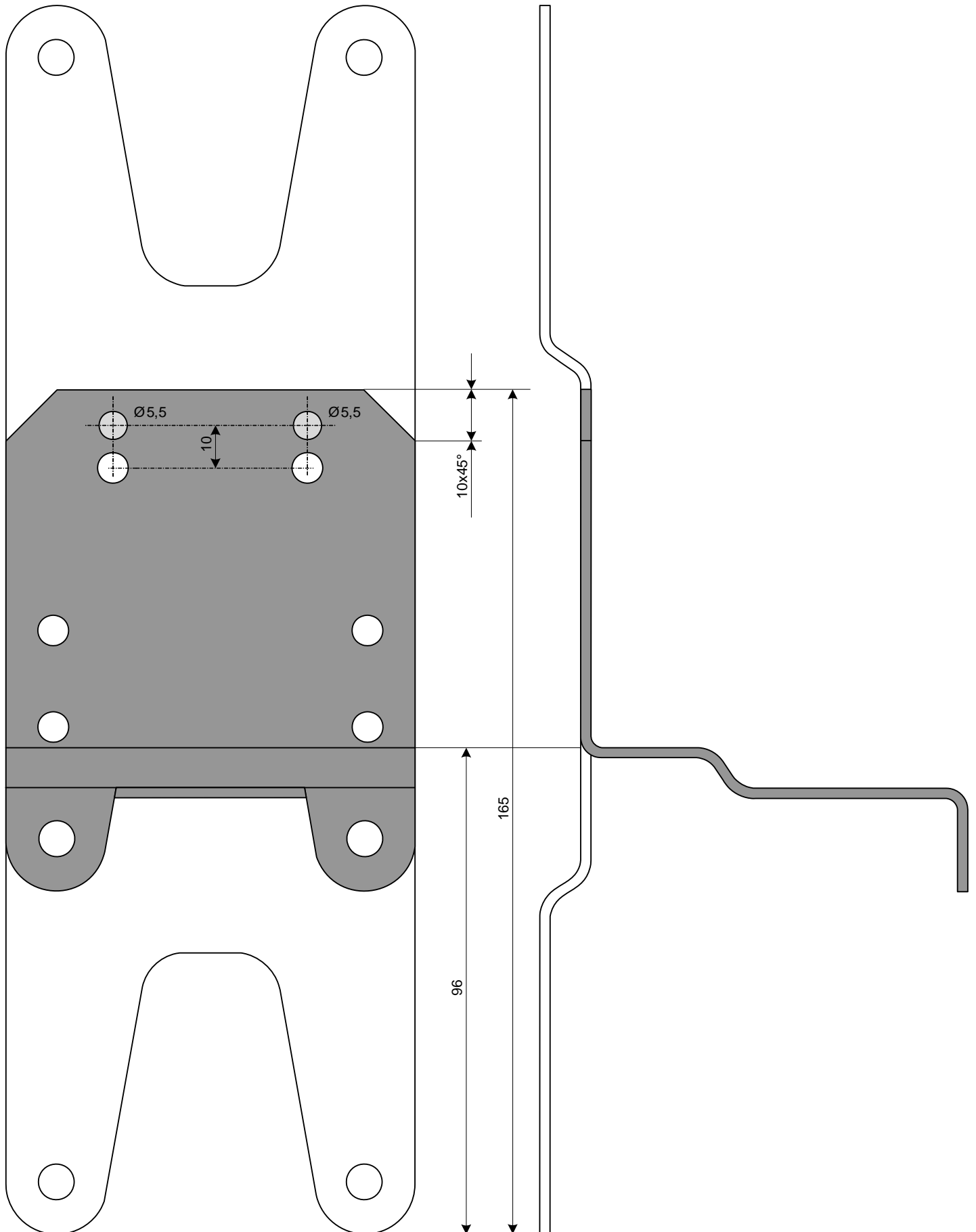

Operating Instructions for End Customer

Please remove this page in case of automatic air-conditioning and add it to the vehicle operating instructions.

Note:

We recommend matching the heating time to the driving time.

Heating time = driving time

Example:

For a driving time of approx. 20 min. (in one direction), we recommend not exceeding a switch-on time of 20 min.

Passenger compartment monitoring, if installed, must be deactivated in addition to the vehicle settings for the heating operation .

For instructions on deactivation, please refer to the operating instructions of the vehicle.

No further settings are required on the A/C control panel.

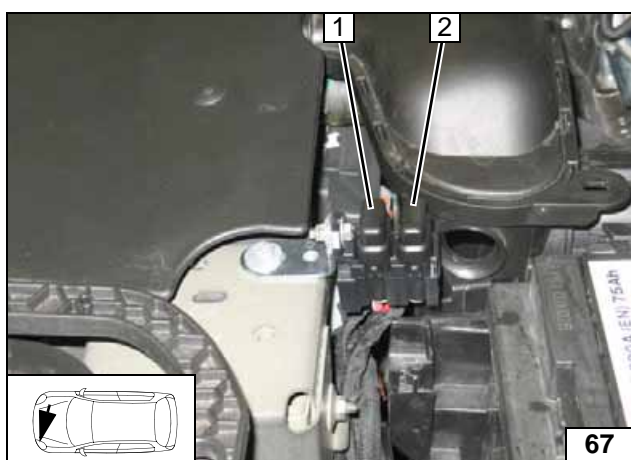

- 1 20A main fuse of passenger compartment F2
- 2 20A heater fuse F1

Fuses of engine compartment

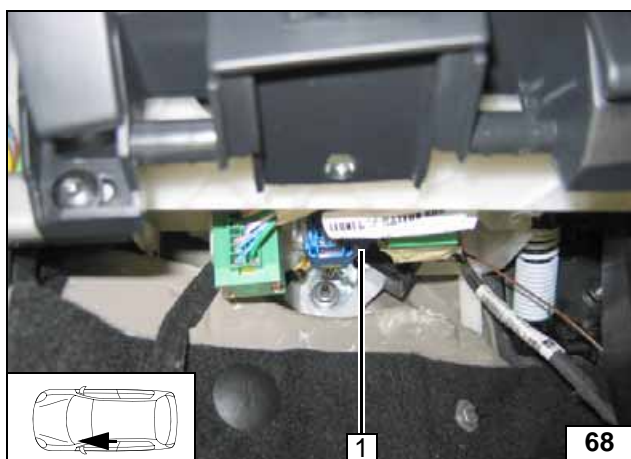

- 1 1A heater control fuse F3 (hidden by fuse holder)

Fuse of passenger compartment

