

Water Heater

Thermo Top Evo Parking Heater



Installation Documentation

Hyundai i20

Validity

Manufacturer	Model	Type	EG-BE No. / ABE		
Hyundai	i20	PBT	e11 * 2007 / 46 * 0129 * ...		
Motorisation	Fuel	Transmission type	Output in kW	Displacement in cm ³	Engine code
1.2	Petrol	6-speed SG	63	1248	G4LA
1.4	Petrol	6-speed SG	74	1396	G4FA
1.4	Petrol	AG	74	1396	G4FA

SG = manual transmission
 AG = automatic transmission

From Model Year 2012
Left-hand drive vehicle

Verified equipment variants: Manual / automatic air-conditioning system
 Daytime running lights
 Front fog lights

Not verified: Passenger compartment monitoring

Total installation time: approx. 7 hours

Hyundai i20

Table of Contents

Validity	1	Preparing Installation Location	16
Necessary Components	2	Preparing Heater	18
Installation Overview	2	Installing Heater	19
Information on Total Installation Time	2	Fuel	20
Information on Operating and Installation Instructions	3	Exhaust Gas	24
Information on Validity	4	Combustion Air	26
Technical Information	4	Coolant Circuit	27
Explanatory Notes on Document	4	1.2 P	28
Preliminary Work	5	1.4 P	29
Heater Installation Location	5	Final Work	31
Preparing Electrical System	6	Template for Fuel Standpipe	32
Electrical System	9	Template for Bracket	33
Fan Controller for Manual Air-Conditioning	10	Operating Instructions for Manual A/C System	34
Fan Controller for Automatic Air-Conditioning	12	Operating Instructions for Automatic Air-Conditioning	35
Digital Timer	15		
Remote Option (Telestart)	15		

Necessary Components

- Basic delivery scope *Thermo Top Evo* in accordance with price list
- Installation kit for Hyundai i20 2012 Petrol **1318857A**
- Heater control in accordance with price list and upon consultation with end customer
- In case of Telestart, indicator lamp in accordance with price list and in consultation with end customer

Installation instructions:

- Arrange for the vehicle to be delivered with the tank only about ¼ full.
- The installation location of the push button for Telestart or Thermo Call must be agreed with the end customer.
- Depending on the space requirement and the manufacturer's instructions for the vehicle, we recommend the use of a vehicle battery with a higher electrical capacity.

Installation Overview

Legend:

1. Heater
2. Engine compartment fuse holder
3. Passenger compartment relay and fuse holder
4. Circulating pump
5. Digital timer
6. Metering pump

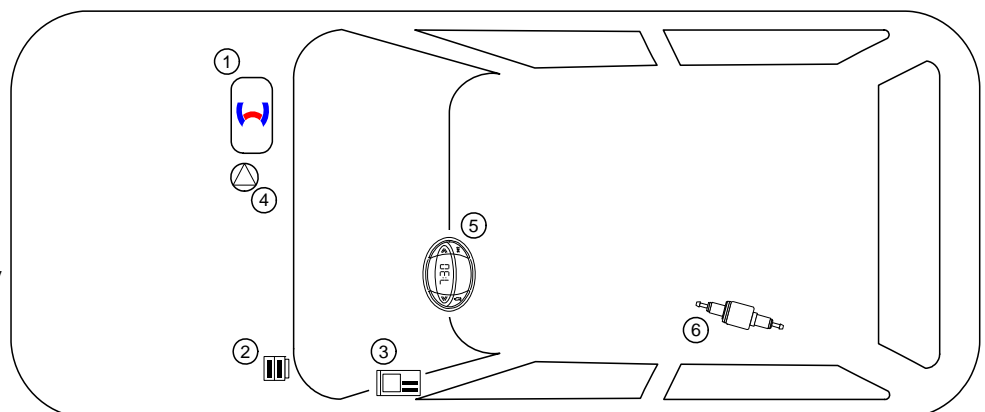

Information on Total Installation Time

The total installation time includes the time needed for mounting and demounting of the vehicle-specific components, the heater specific installation time and all other times required for the system integration and initial start-up of the heater.

The total installation time may vary for vehicle equipment other than provided.

Information on Operating and Installation Instructions

1 Important Information (not complete)

1.1 Installation and Repair



The improper installation or repair of Webasto heating and cooling systems can cause fire or the leakage of deadly carbon monoxide, leading to serious injury or death.



To install and repair Webasto heating and cooling systems you need to have completed a special company training course and have the appropriate technical documentation, special tools and special equipment.



Installation and repair may ONLY be carried out by persons trained and certified in a Webasto training course. NEVER try to install or repair Webasto heating or cooling systems if you have not completed a Webasto training course, you do not have the necessary technical skills and you do not have the technical documentation, tools and equipment available to ensure that you can complete the installation and repair work properly.

Only use genuine Webasto parts. See the Webasto air and water heaters accessories catalogue for this purpose.

1.2 Operation

To ensure safe operation, we recommend having the heater checked every two years by an authorised Webasto dealer, especially when used over a long period and/or under extreme environmental conditions.

Do not operate the heater in closed rooms due to the danger of poisoning and suffocation.

Always switch off the heater before refuelling.

The heater may only be used with the prescribed fuel Diesel (DIN EN 590) or petrol (DIN EN 228).

The heater may not be cleaned with a high-pressure cleaner.

1.3 Please note

ALWAYS follow all Webasto installation and operating instructions and observe all warnings.

To become familiar with and understand all functions and properties of the heater, the operating instructions must be read carefully and observed at all times.

For proper, safe installation and repair work, the installation instructions with all warnings and safety information must be carefully read and observed at all times. Please always contact a workshop authorised by Webasto for all installation and repair work.

Important

Webasto shall assume no liability for defects, damage and injuries resulting from a failure to observe the installation, repair and operating instructions of the information contained in them.

This liability exclusion particularly applies to improper installations and repairs, installations and repairs by untrained persons or in the case of a failure to use genuine spare parts.

The liability due to culpable disregard to life, limb or health and due to damage or injuries caused by a wilful or reckless breach of duty remain unaffected, as does the obligatory product liability.

Installation should be carried out according to the general, standard rules of technology. Unless specified otherwise, fasten hoses, lines and wiring harnesses to original vehicle lines and wiring harnesses using cable ties. Insulate loose wire ends and tie back. Connectors on electronic components must audibly snap into place during assembly.

Sharp edges should be fitted with rub protection. Spray unfinished body areas, e.g. drilled holes, with anti-corrosion wax (Tectyl 100K, Order No. 111329).

Observe the instructions and guidelines of the respective vehicle manufacturer for demounting and mounting vehicle specific components!

The initial startup is to be executed with the Webasto Thermo Test Diagnosis.

When installing a programmable control module (e.g. a PWM Gateway), the corresponding settings must be checked or adjusted.

2 Statutory regulations governing installation

Guidelines	Thermo Top Evo
Heating Directive ECE R122	E1 00 0258
EMC Directive ECE R10	E1 04 5627

Note

The regulations of these guidelines are binding in the scope of the Directive 70/156/EEC and/or 2007/46/EC (for new vehicle models from 29/04/2009) and should also be observed in countries in which there are no special regulations.

Important

Failure to follow the installation instructions will result in the invalidation of the type approval for the heater and therefore invalidation of the general **homologation of the vehicle**.

Note

The heater is licensed in accordance with paragraph 19, section 3, No. 2b of the StVZO (German Road Traffic Licensing Authority).

2.1 Excerpt from ECE regulation 122 (heating system) paragraph 5 for the installation of the heater

Beginning of excerpt.

ANNEX VII

REQUIREMENTS FOR COMBUSTION HEATERS AND THEIR INSTALLATION

1. GENERAL REQUIREMENTS

1.7.1. A clearly visible tell-tale in the operator's field of view shall inform when the combustion heater is switched on or off.

2. VEHICLE INSTALLATION REQUIREMENTS

2.1. Scope

2.1.1. Subject to paragraph 2.1.2. combustion heaters shall be installed according to the requirements of this Annex.

2.1.2. Vehicles of category O having liquid fuel heaters are deemed to comply with the requirements of this Annex.

2.2. Positioning of heater

2.2.1. Body sections and any other components in the vicinity of the heater must be protected from excessive heat and the possibility of fuel or oil contamination.

2.2.2. The combustion heater shall not constitute a risk of fire, even in the case of overheating. This requirement shall be deemed to be fulfilled if the installation ensures an adequate distance to all parts and suitable ventilation, by the use of fire resistant materials or by the use of heat shields.

2.2.3. In the case of M2 and M3 vehicles, the heater must not be positioned in the passenger compartment. However, an installation in an effectively sealed envelope which also complies with the conditions in paragraph 2.2.2 may be used.

2.2.4. The label referred to in paragraph 1.4 or a duplicate, must be positioned so that it can be easily read when the heater is installed in the vehicle.

2.2.5. Every reasonable precaution should be taken in positioning the heater to minimise the risk of injury and damage to personal property.

2.3. Fuel supply

2.3.1. The fuel filler must not be situated in the passenger compartment and must be provided with an effective cap to prevent fuel spillage.

2.3.2. In the case of liquid fuel heaters, where a supply separate to that of the vehicle is provided, the type of fuel and its filler point must be clearly labelled.

2.3.3. A notice, indicating that the heater must be shut down before refuelling, must be affixed to the fuelling point. In addition a suitable instruction must be included in the manufacturer's operating manual.

2.4. Exhaust system

2.4.1. The exhaust outlet must be located so as to prevent emissions from entering the vehicle through ventilators, heated air inlets or opening windows.

2.5. Combustion air inlet

2.5.1. The air for the combustion chamber of the heater must not be drawn from the passenger compartment of the vehicle.

2.5.2. The air inlet must be so positioned or guarded that blocking by rubbish or luggage is unlikely.

2.6. Heating air inlet

2.6.1. The heating air supply may be fresh or recirculated air and must be drawn from a clean area not likely to be contaminated by exhaust fumes emitted either by the propulsion engine, the combustion heater or any other vehicle source.

2.6.2. The inlet duct must be protected by mesh or other suitable means.

2.7. Heating air outlet

2.7.1. Any ducting used to route the hot air through the vehicle must be so positioned or protected that no injury or damage could be caused if it were to be touched.

2.7.2. The air outlet must be so positioned or guarded that blocking by rubbish or luggage is unlikely.

End of excerpt.

In multilingual versions the German language is binding.

Hyundai i20

Information on Validity

This installation documentation applies to Hyundai i20 Petrol vehicles - for validity, see page 1 - from model year 2012 and later, assuming technical modifications to the vehicle do not affect installation, any liability claims excluded. Depending on the vehicle version and equipment, modifications may be necessary during installation with respect to this installation documentation.

Vehicle and engine types, equipment variants and other specifications not listed in this installation documentation have not been tested. However, installation according to this installation documentation may be possible.

Technical Information

Special Tools

- Hose clamp pliers for self-clamping hose clamps
- Hose clamp pliers for Clic hose clamps of type W
- Automatic wire stripper 0.2 - 6mm²
- Crimping pliers for cable lug / tab connector 0.5 - 6mm²
- Torque wrench for 2.0 - 10 Nm
- Hose clamping pliers
- Metric thread-setter kit
- Webasto Thermo Test diagnosis with current software

Dimensions

- All dimensions are in mm.











Tightening torque values

- Tightening torque values of 5x13 heater bolts and heater stud bolts = 8Nm.
- Tightening torque values of 5x15 retaining plate of water connection piece bolt = 7Nm.
- Tighten other bolt connections in accordance with manufacturer's instructions or in accordance with state-of-the-art-technology.

Explanatory Notes on Document

You will find an identification mark on the outside top right corner of the page in question to provide you with a quick overview of the individual working steps.

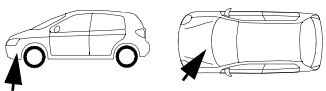
Special features are highlighted using the following symbols:

Mechanical system		Specific risk of injury or fatal accidents	
Electrical system		Specific risk due to electrical voltage	
Coolant circuit		Specific risk of damage to components	
Combustion air		Specific risk of fire or explosion	
Fuel		Reference to general installation instructions of the Webasto components or to the manufacturer's vehicle-specific documents	
Exhaust gas		Reference to a special technical feature	
Software		The arrow in the vehicle icon indicates the position on the vehicle and the viewing angle	
		Tightening torque according to the manufacturer's vehicle-specific documents	

Hyundai i20

Preliminary Work

Vehicle

- Open the fuel tank cap.
- Ventilate the fuel tank.
- Close the fuel tank cap again.
- Depressurise the cooling system.
- Disconnect and completely remove the battery together with the carrier.
- Remove the air filter together with the intake hose.
- Remove the instrument panel trim on the driver's side.
- Disconnect the central electrical box of the passenger compartment and lay it aside.
- Remove the air ducting in the driver's side footwell.
- Remove the rear bench seat.
- Open the tank-fitting service lid.
- Remove the fuel-tank sending unit in accordance with the manufacturer's instructions.
- Remove the lower trim on the driver's side.

Heater

- Remove years that do not apply from the type and duplicate label.
- Attach the duplicate label (type label) in the appropriate place in the engine compartment.

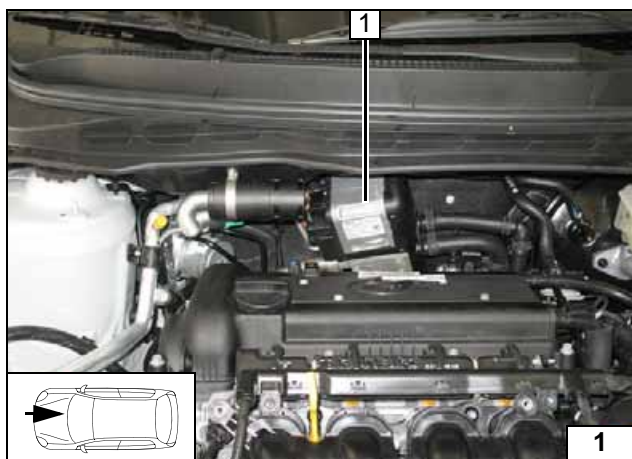

Heater Installation Location

1 Heater

Installation location

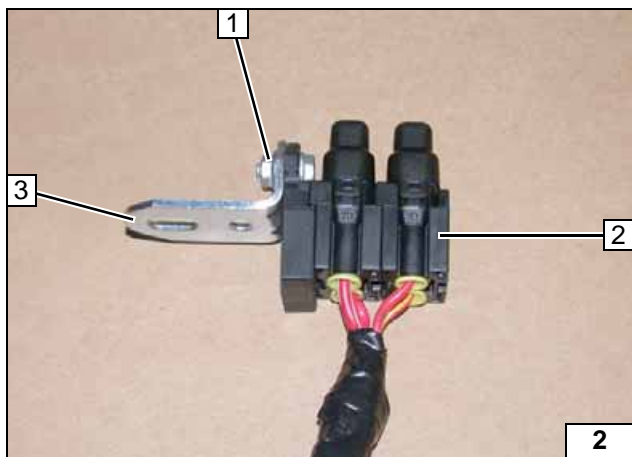

Preparing Electrical System

Wire sections retain their numbering in the entire document.

Produce all following electrical connections as shown in wiring diagram.

- 1 M5x16 bolt, washer [2x], retaining plate, fuse holder, nut
- 2 Engine compartment fuse holder
- 3 Angle bracket



Preparing engine compartment fuse holder

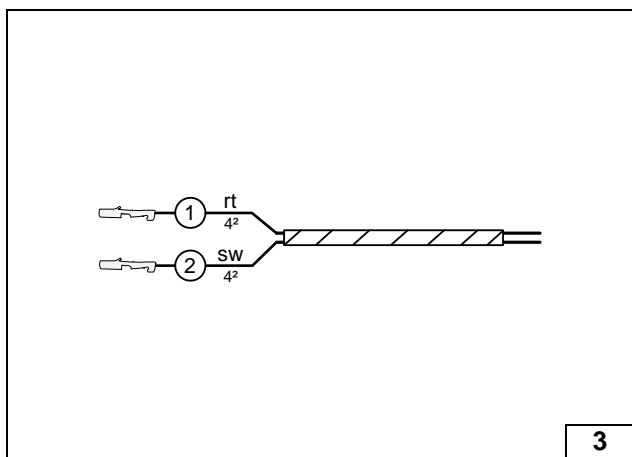

Manual A/C system

- ① Red (rt) wire of fan wiring harness
- ② Black (sw) wire of fan wiring harness

Assigning wires

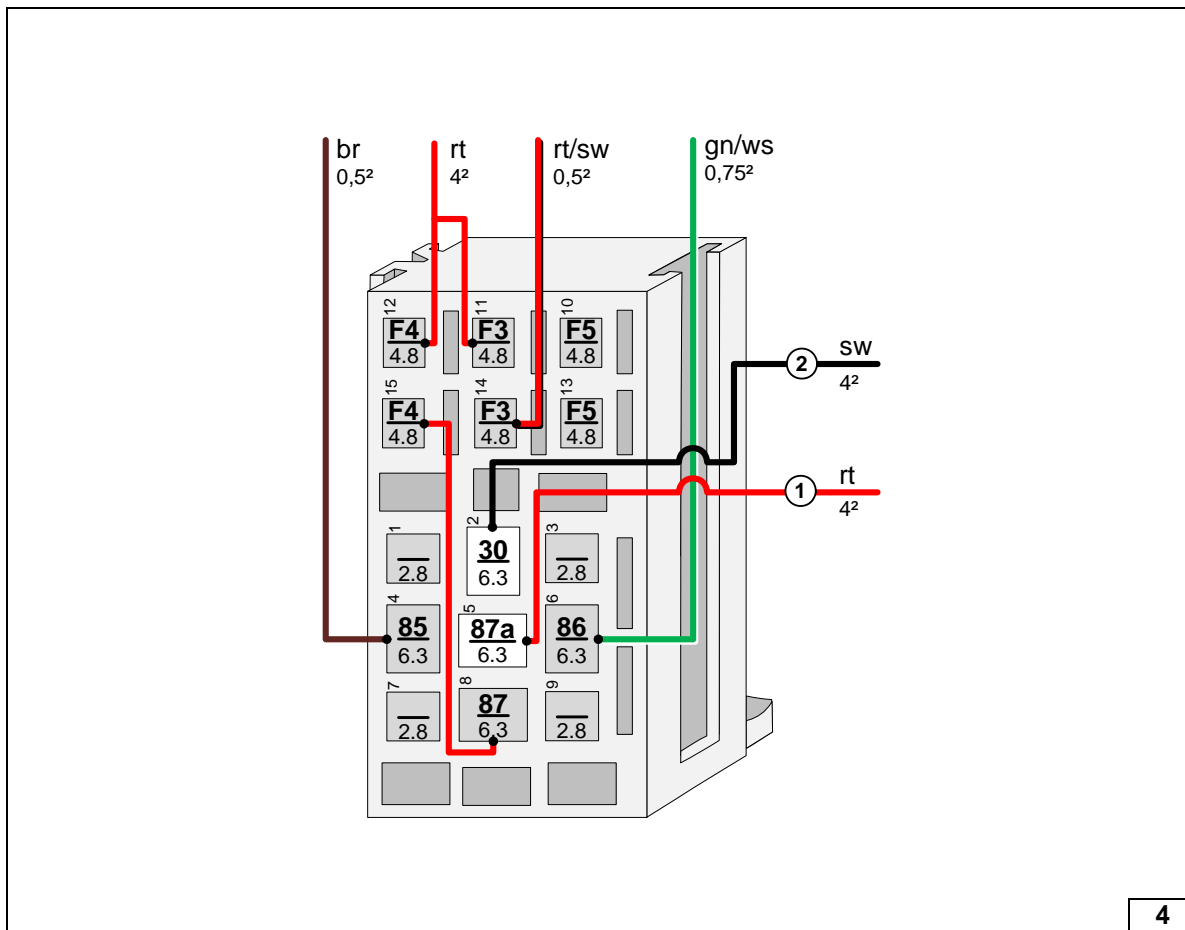

Connecting wires to socket of passenger compartment relay and fuse holder

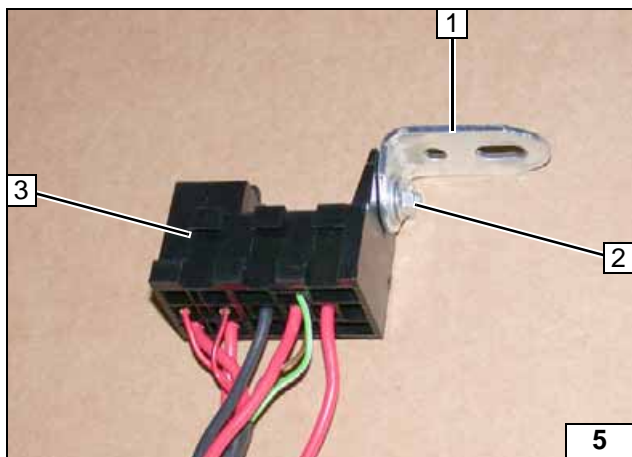

- 1 Angle bracket
- 2 M5x16 bolt, washer [2x], nut
- 3 Passenger compartment relay and fuse holder



Preparing passenger compartment relay and fuse holder

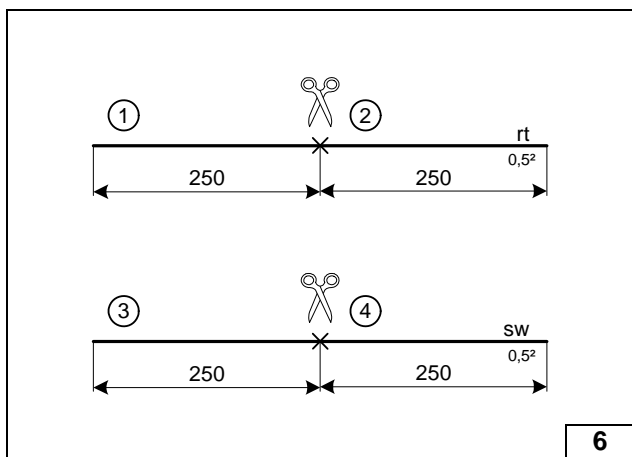

Automatic air-conditioning

Cutting to length / assigning wires

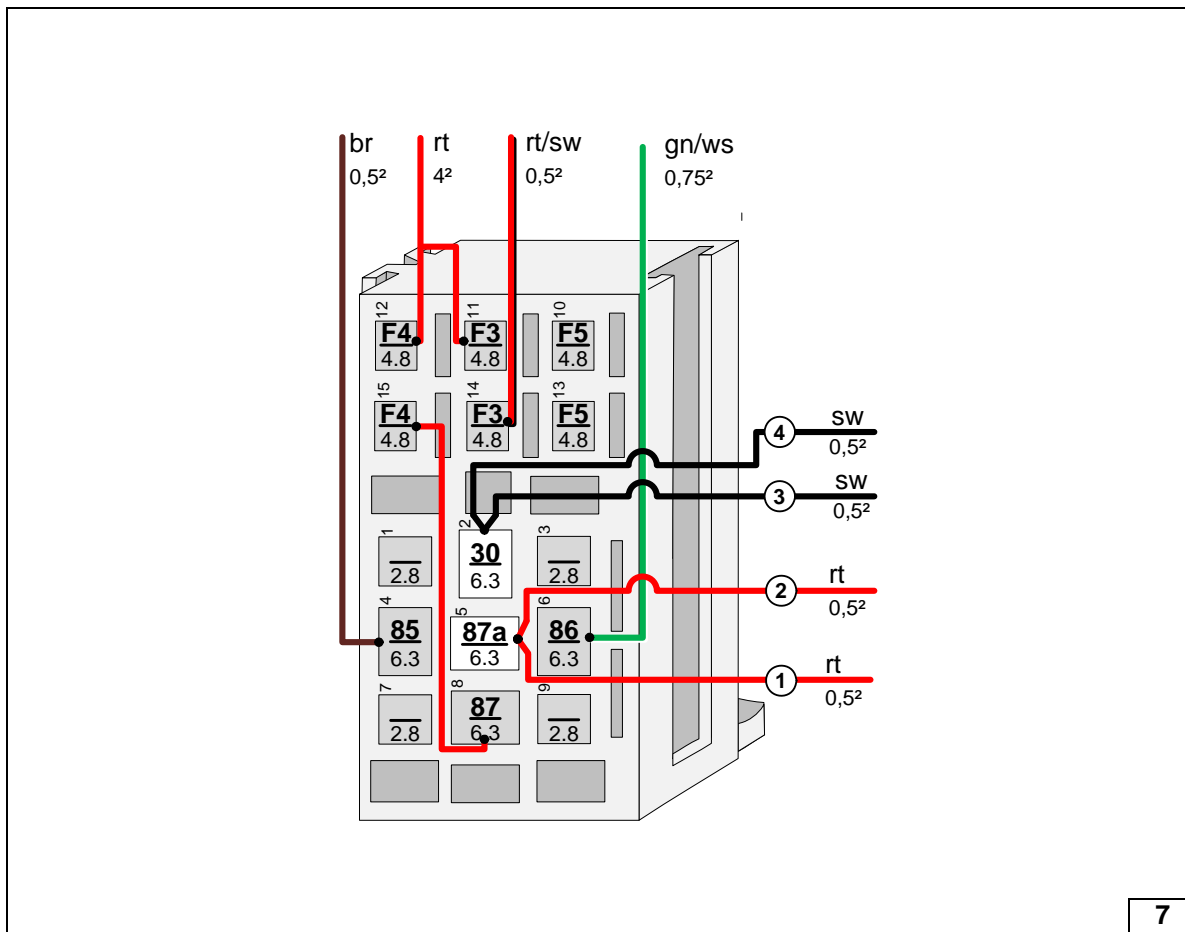

Connecting wires to socket of passenger compartment relay and fuse holder

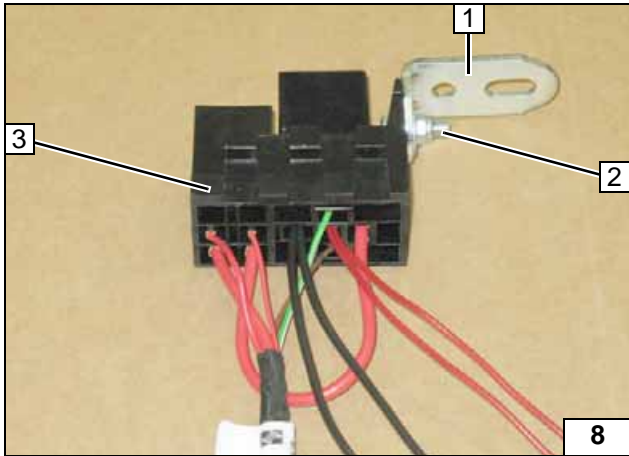

- 1 Angle bracket
- 2 M5x16 bolt, washer [2x], nut
- 3 Passenger compartment relay and fuse holder

Preparing passenger compartment relay and fuse holder

All vehicles

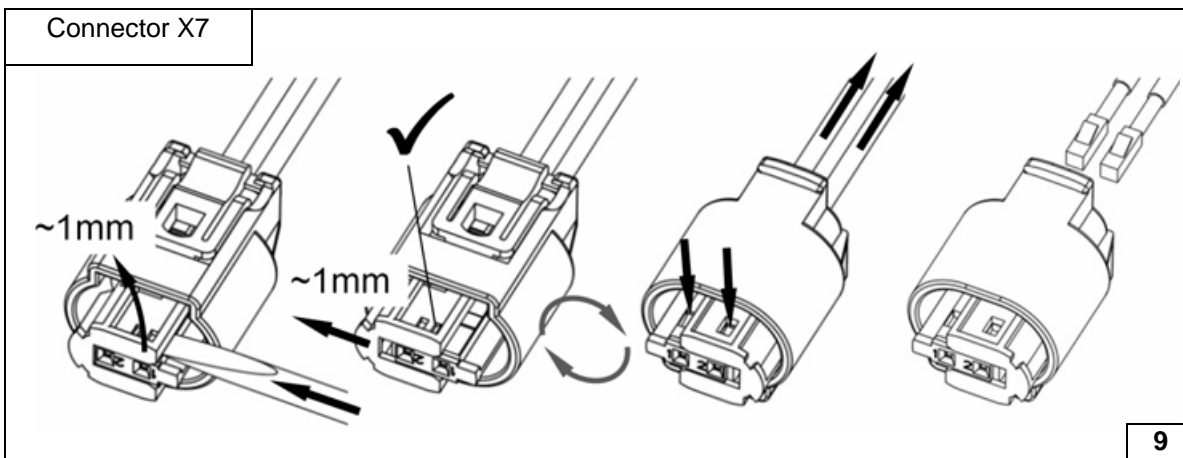

Removing metering pump connector



Electrical System

Positive wire

- 1 Positive wire on positive distributor

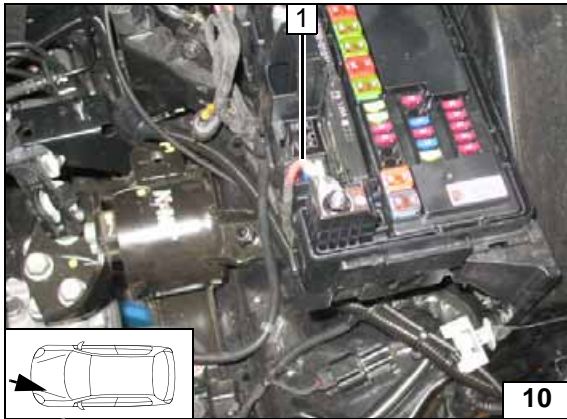

Wiring harness pass through

- 1 Protective rubber plug

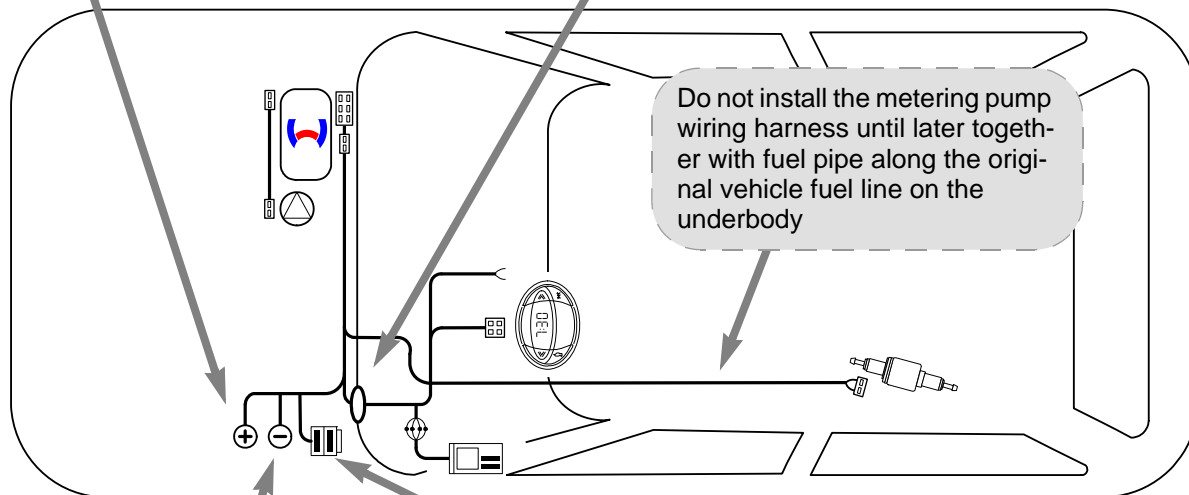
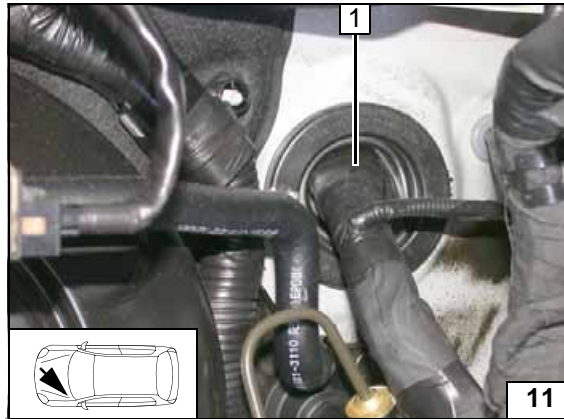

Wiring harness routing diagram

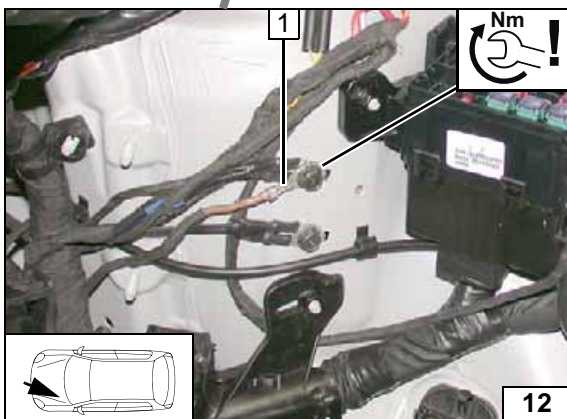

Earth wire

- 1 Earth wire on original vehicle earth support point

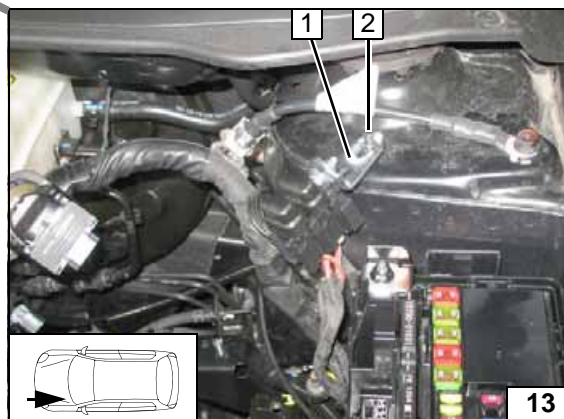

Fuse holder for engine compartment

Attach fuse holder, will be installed during "Final Work".

- 1 Angle bracket
- 2 Original vehicle bolt





Fan Controller for Manual Air-Conditioning

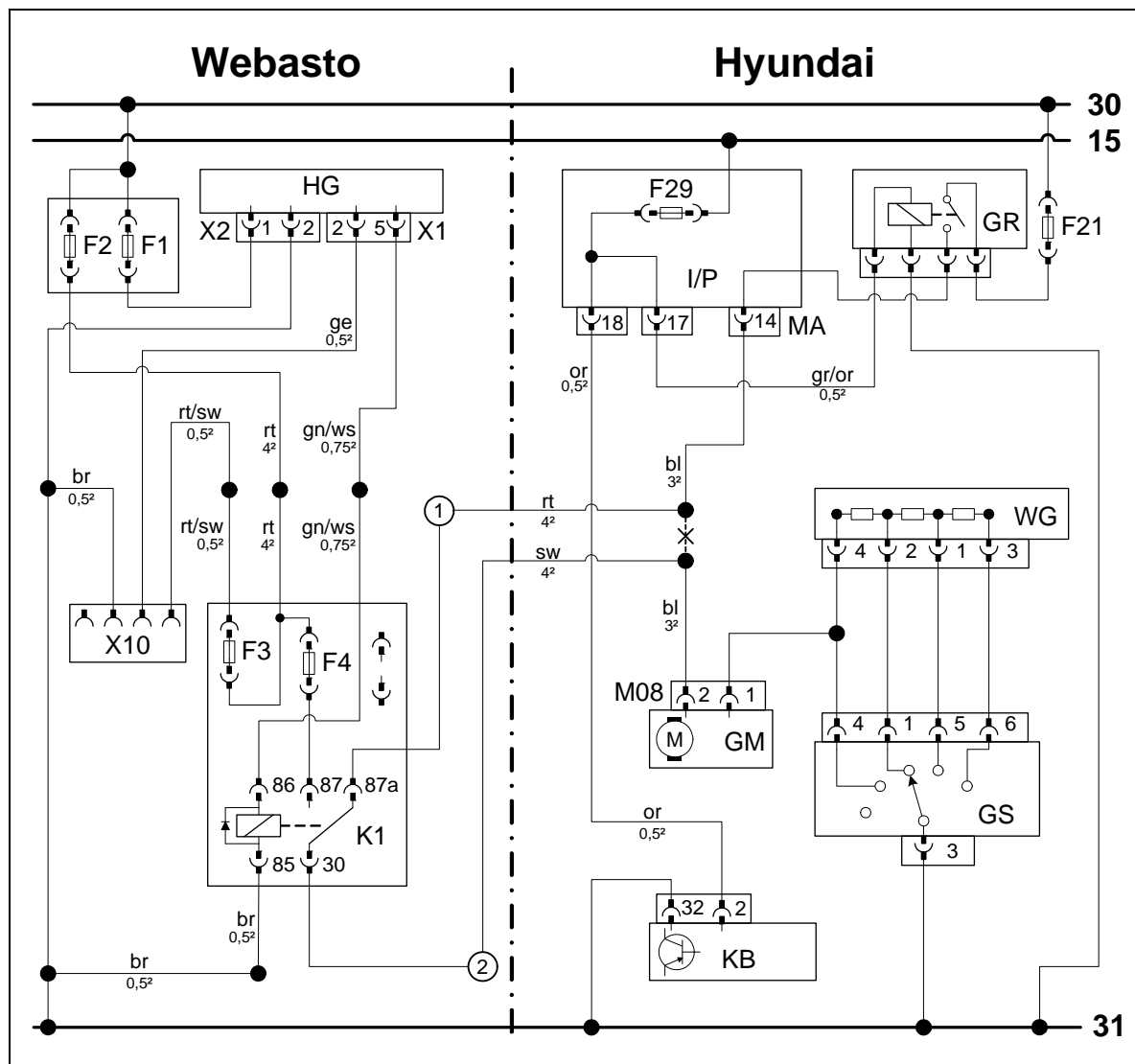

Wiring diagram

Webasto components		Vehicle components		Colours and symbols	
HG	TT-Evo heater	I/P	Central electrical box for passenger compartment	rt	red
X1	6-pin heater connector	F29	10A fuse	sw	black
X2	2-pin heater connector	MA	I/P connector	ge	yellow
F1	20A fuse	GR	Fan relay	gn	green
F2	30A fuse	F21	40A fuse	br	brown
X10	4-pin connector of heater control	WG	Resistor group	ws	white
K1	Fan relay	GM	Fan motor	bl	blue
F3	1A fuse	M08	Connector GM	or	orange
F4	25A fuse	GS	Fan switch	gr	grey
		KB	A/C control unit	X	Cutting point
Wiring colours may vary.					

Legend

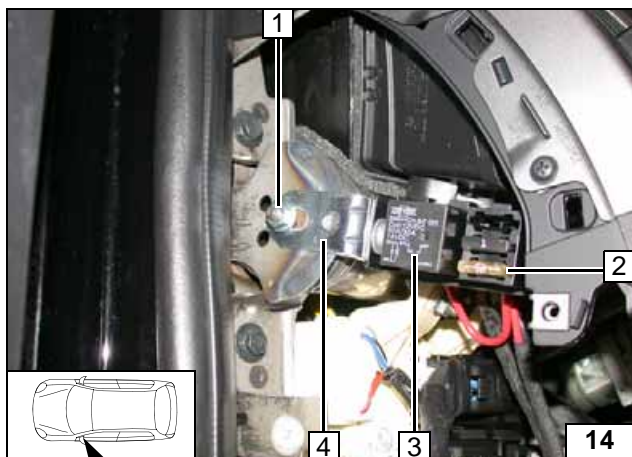

- 1 Original vehicle stud bolt, M6 flanged nut
- 2 25A fuse F4
- 3 K1 relay
- 4 Angle bracket

Installing passenger compartment relay and fuse holder

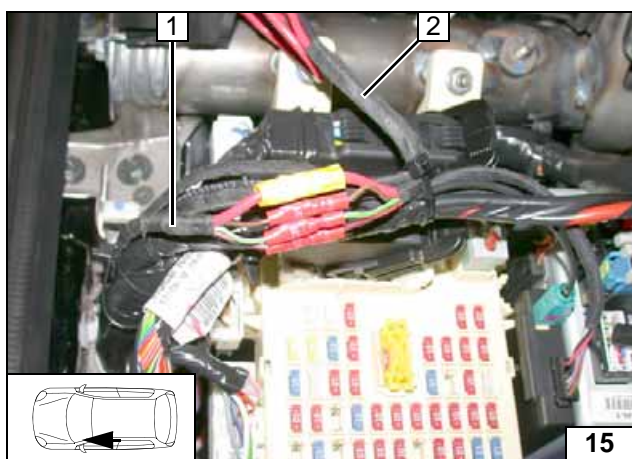

Connect wiring harness of passenger compartment relay and fuse holder **2** to wiring harness of heater **1** according to wiring diagram, in such a way that wires of the same colour are connected to each other.



Connecting wiring harnesses

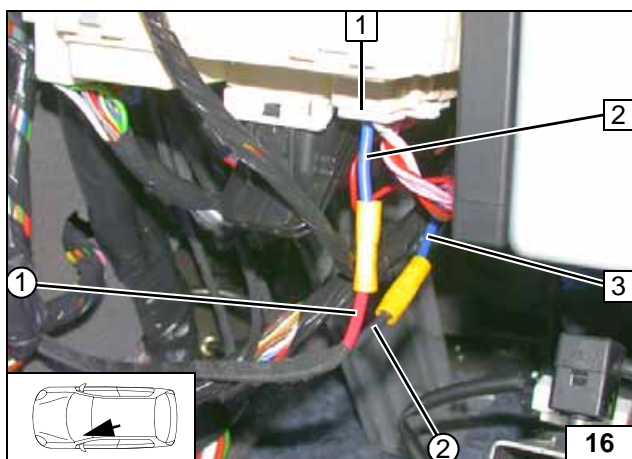

Connection to central electrical box, I/P connector MA **1** (connector behind central electrical box).

- 2 Blue (bl) wire from central electrical box I/P, connector MA, pin 14
- 3 Blue (bl) wire of fan motor
- ① Red (rt) wire of K1/87a, fan wiring harness
- ② Black (sw) wire of K1/30, fan wiring harness



Connection of central electrical box

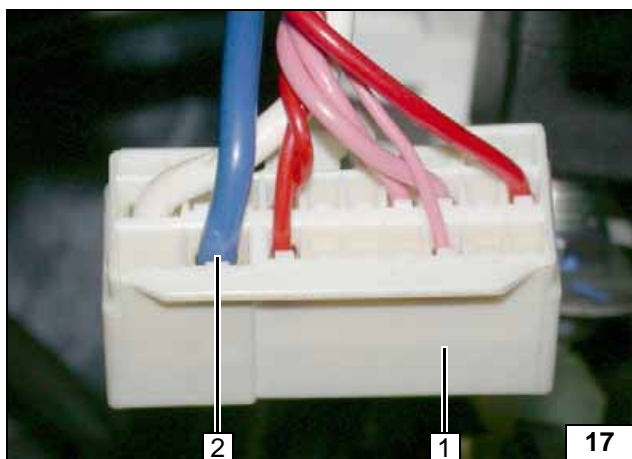

- 1 I/P connector MA of central electrical box
- 2 Socket of blue (bl) 3² wire, Pin 14

View of connector I/P-MA



Fan Controller for Automatic Air-Conditioning

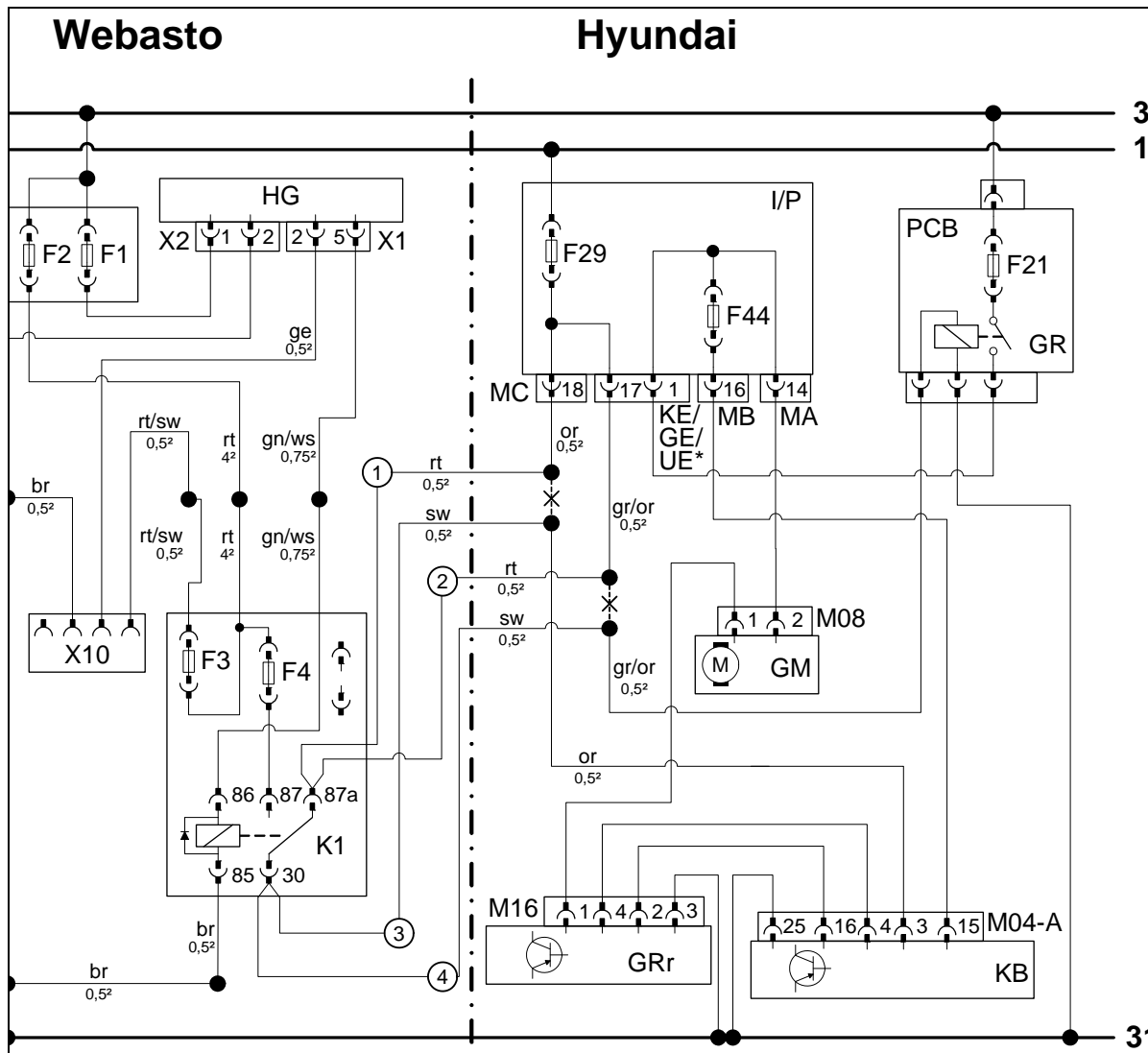

Wiring diagram

Webasto components		Vehicle components		Colours and symbols	
HG	TT-Evo heater	I/P	Central electrical box for passenger compartment	rt	red
X1	6-pin heater connector	F29	10A fuse	sw	black
X2	2-pin heater connector	F44	10A fuse	ge	yellow
F1	20A fuse	MC	I/P connector	gn	green
F2	30A fuse	KE/GE/UE*	I/P connector, depending on engine	br	brown
X10	4-pin connector of heater control	MB	I/P connector	ws	white
K1	Fan relay	MA	I/P connector	or	orange
F3	1A fuse	PCB	Fuse and relay box	gr	grey
F4	10A fuse	F21	40A fuse		
		GR	Fan relay		
		GM	Fan motor		
		M08	Connector GM		
		GRr	Fan controller		
		M16	Connector GRr		
		KB	A/C control unit	X	Cutting point
		M04-A	KB Connector	Wiring colours may vary.	

Legend

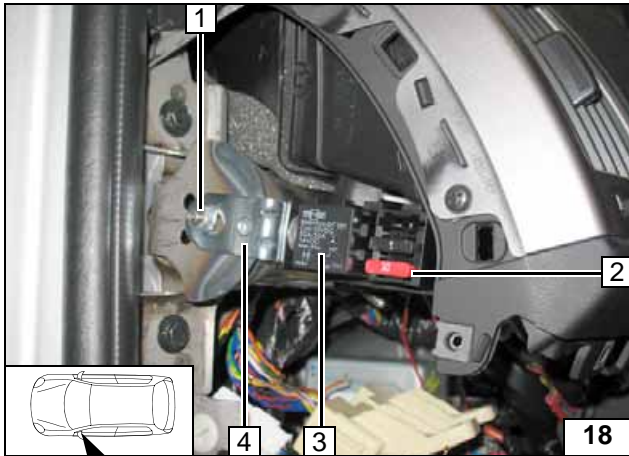

- 1 Original vehicle stud bolt, M6 flanged nut
- 2 10A fuse F4
- 3 K1 relay
- 4 Angle bracket

Installing passenger compartment relay and fuse holder

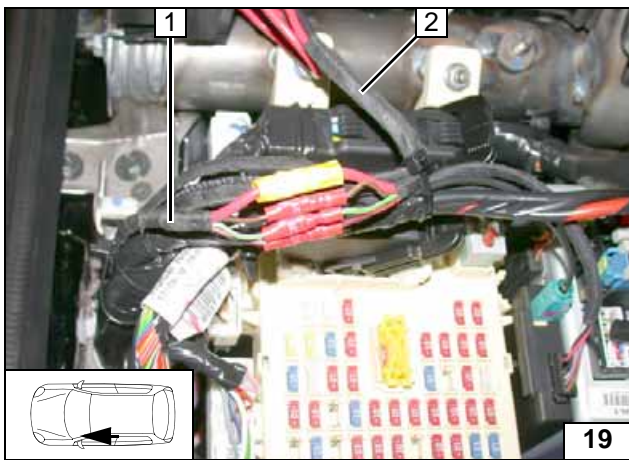

Connect wiring harness of passenger compartment relay and fuse holder 2 to wiring harness of heater 1 according to wiring diagram, in such a way that wires of the same colour are connected to each other.



Connecting wiring harnesses

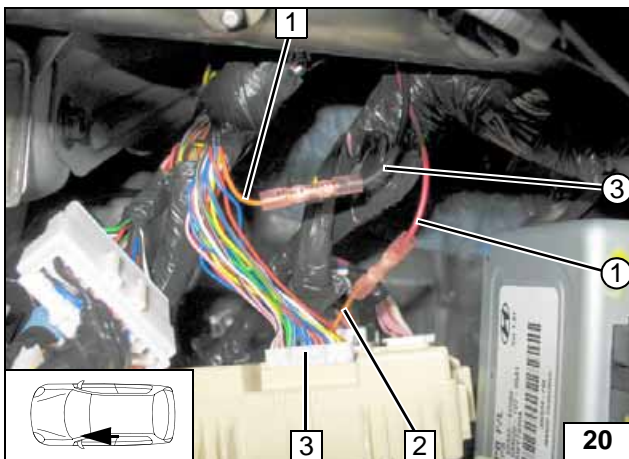

Connection to central electrical box, I/P connector MC 3 (connector behind central electrical box).

- 1 Orange (or) wire from A/C control unit connector M04-A, pin 3
- 2 Orange (or) wire from central electrical box I/P, connector MC, pin 18
- ① Red (rt) wire of K1/87a
- ③ Black (sw) wire of K1/30



Connection of central electrical box

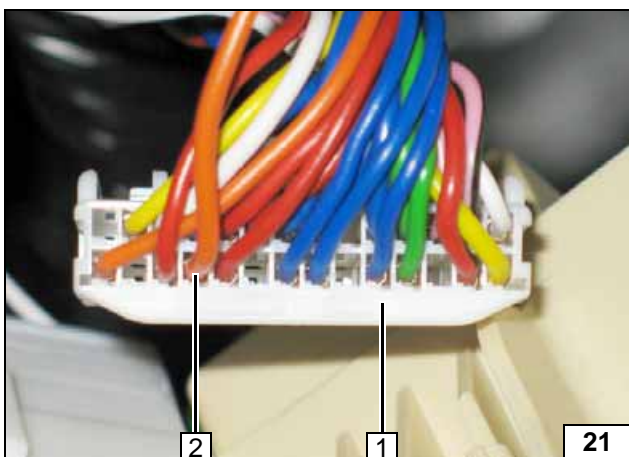

- 1 I/P connector MC of central electrical box
- 2 Socket of orange (or) wire, Pin 18

View of connector I/P-MC

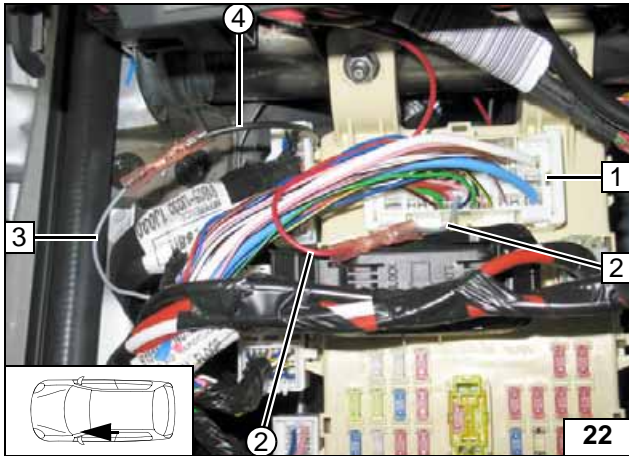

Connection to connector 1 of central electrical box I/P (connector on central electrical box, front).

- 2 Grey/orange (gr/or) wire from central electrical box I/P connector, Pin 17
- 3 Grey/orange (gr/or) wire from fan relay
- ② Red (rt) wire of K1/87a
- ④ Black (sw) wire of K1/30

**Connec-
tion of cen-
tral
electrical
box**

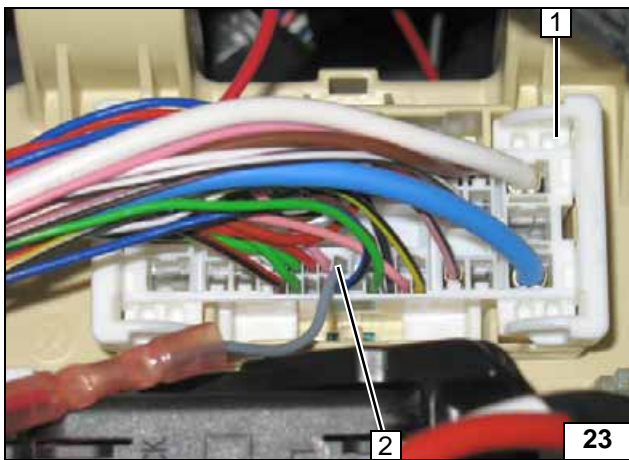

- 1 Connector of central electrical box I/P
- 2 Socket of grey/orange (gr/or) wire, Pin 17

**View of
connector**

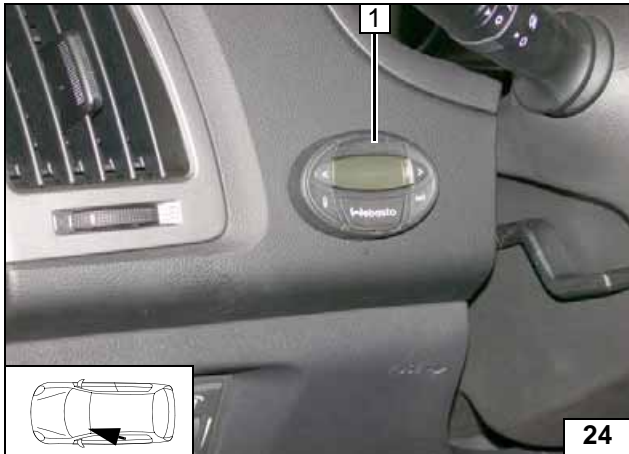

Digital Timer

1 Digital timer



Mounting digital timer

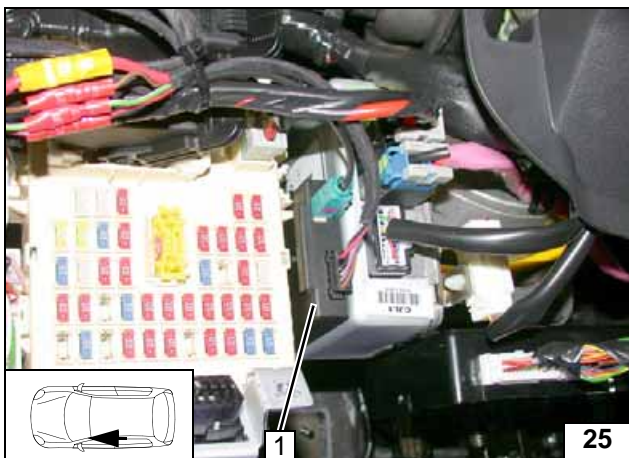

Remote Option (Telestart)

Fasten receiver 1 with adhesive tape.



Installing receiver

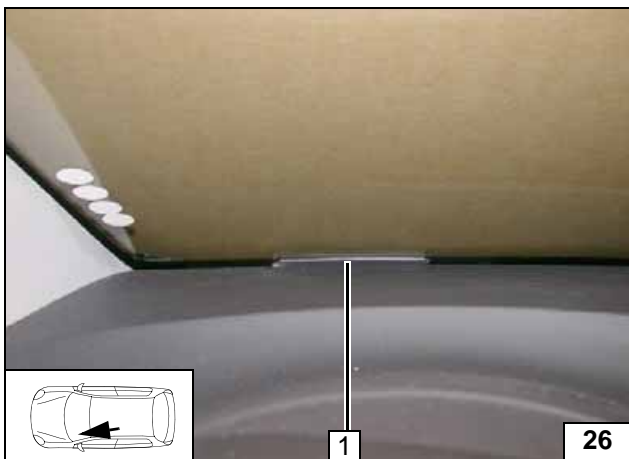

1 Antenna

Installing antenna

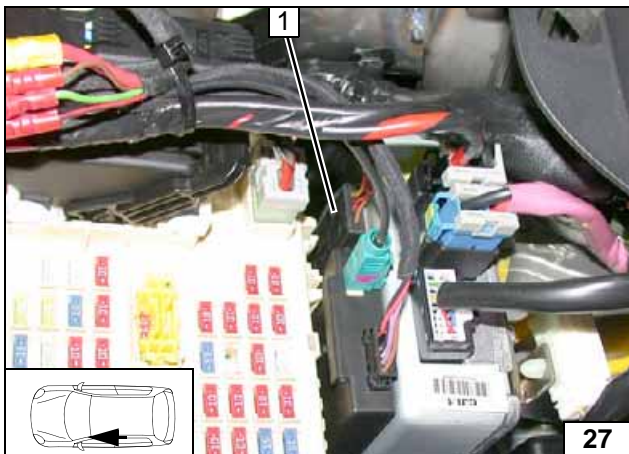

Temperature sensor T100 HTM

Fasten temperature sensor 1 with adhesive tape.



Installing temperature sensor

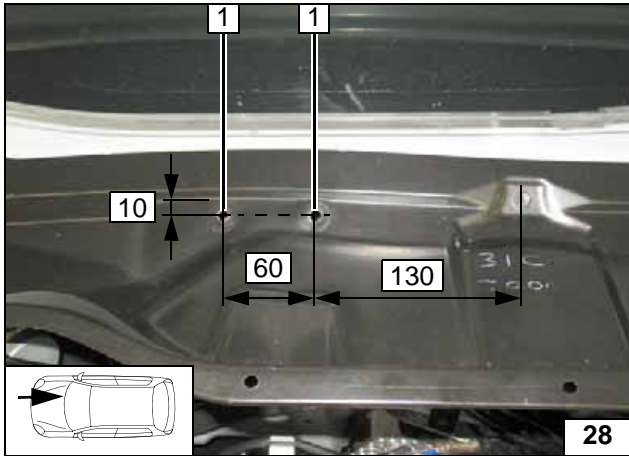

Preparing Installation Location

- 1 7mm dia. hole [2x]

Holes in coolant reservoir cap

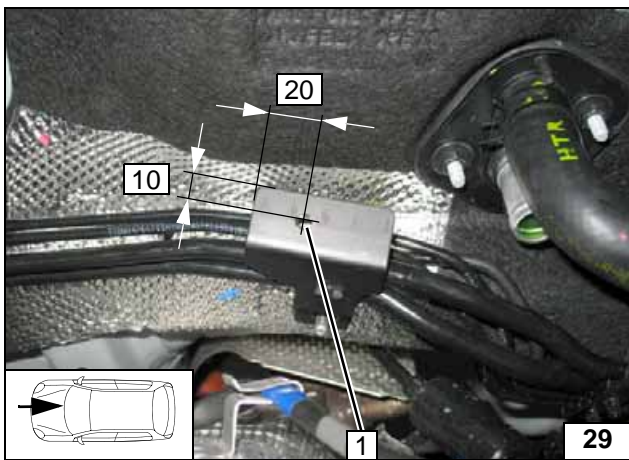

Mind components located behind when drilling. Cover brake lines.

- 1 7 mm dia. hole

Hole in bracket of brake lines

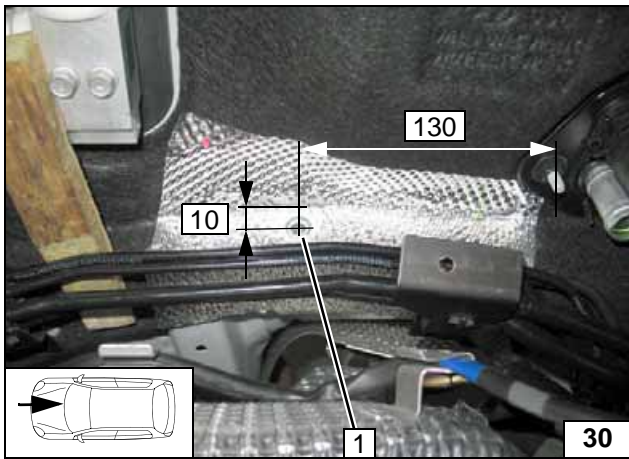

Loosen both cable ducts. Keep brake lines at a distance using chock for drilling. Cut out insulation and heat shield in the area of the rivet nut. Copy hole pattern at position 1.

- 1 9.1 mm dia. hole, rivet nut

Installing rivet nut

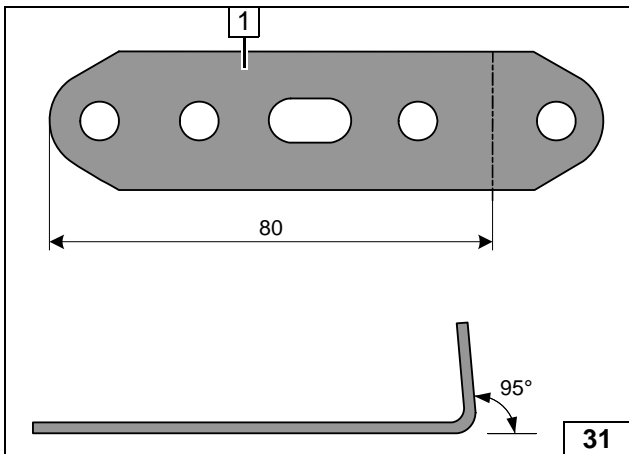

- 1 Perforated bracket

Preparing perforated bracket

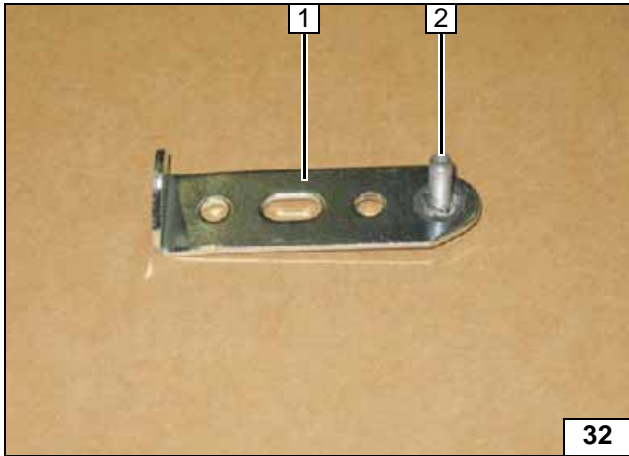
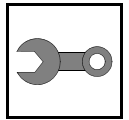

- 1 Perforated bracket
- 2 M6x20 bolt, pin lock

Preparing perforated bracket

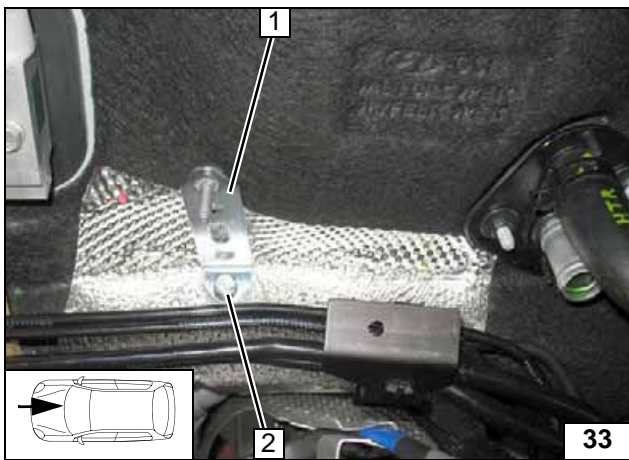

- 1 Perforated bracket
- 2 M6x20 bolt, spring lockwasher

Mounting perforated bracket

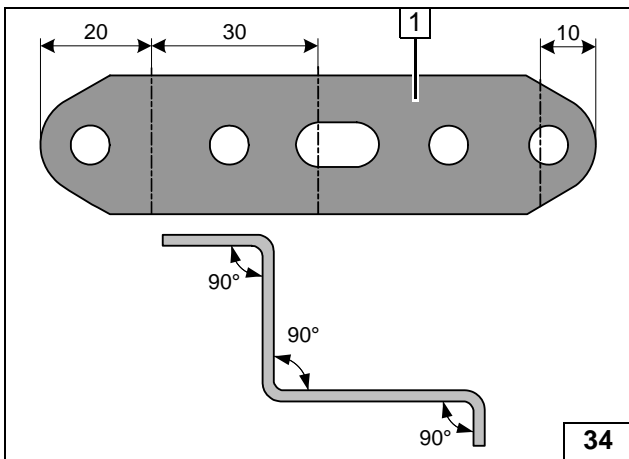

- 1 Perforated bracket



Preparing perforated bracket

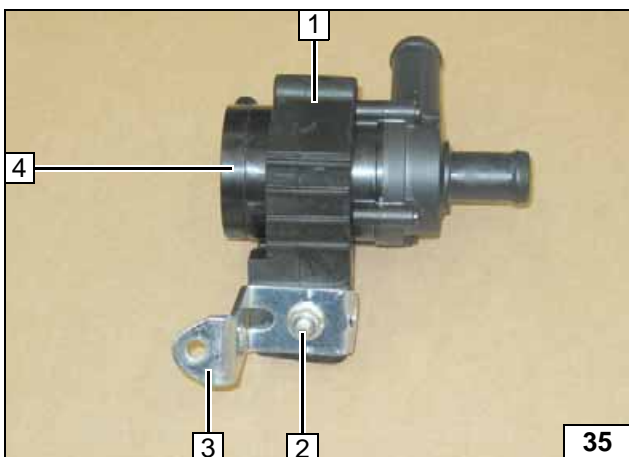

- 1 Mounting for circulating pump
- 2 M6x25 bolt, flanged nut
- 3 Perforated bracket
- 4 Circulating pump

Premounting circulating pump

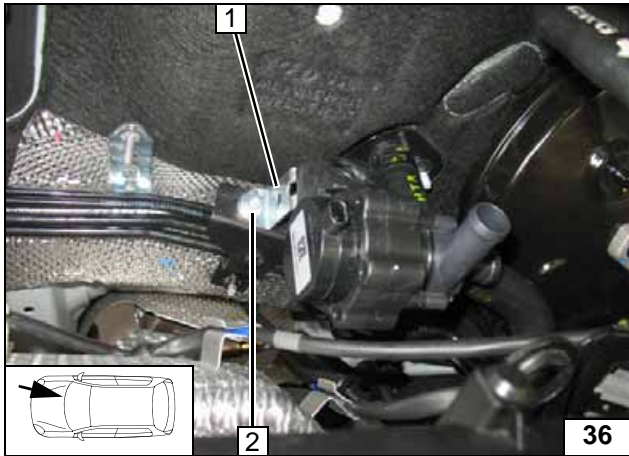

- 1 Perforated bracket
- 2 M6x12 bolt, flanged nut

Mounting circulating pump

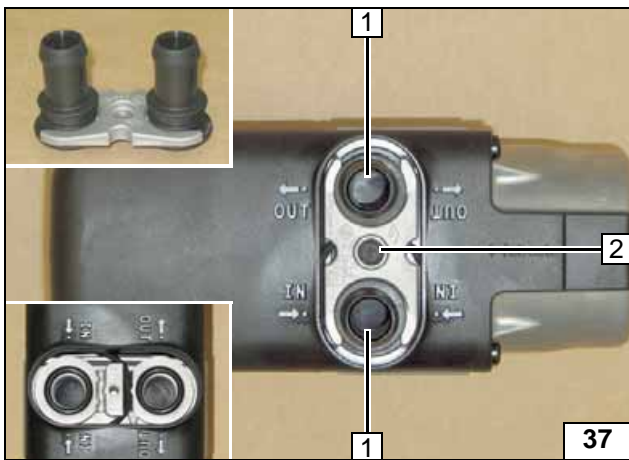

Preparing Heater

- 1 Water connection piece, sealing ring [2x each]
- 2 Self-tapping bolt 5x15, retaining plate of water connection piece



Mounting water connection piece

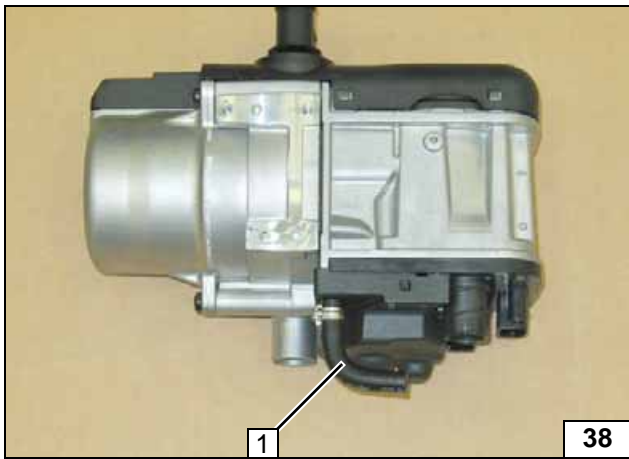

- 1 90° moulded hose, 10 mm dia. clamp

Mounting moulded hose

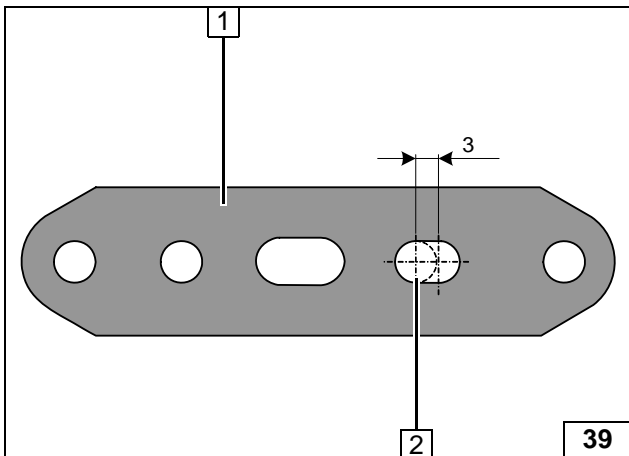

Enlarge hole at position 2.

- 1 Perforated bracket



Preparing perforated bracket

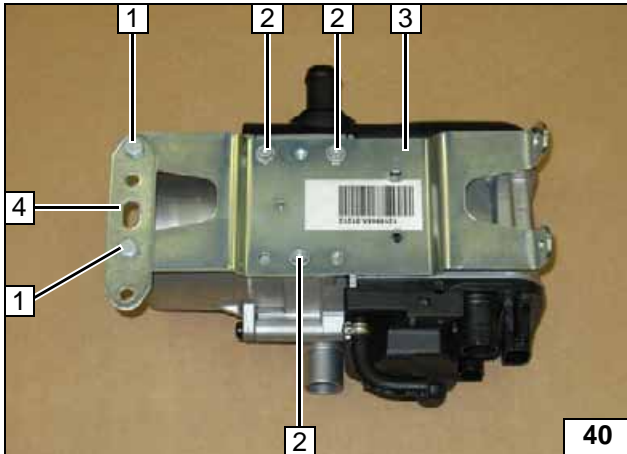

Angle down bracket **3** as per template.

- 1 M6x12 bolt, flanged nut [2x each]
- 2 Self-tapping bolt 5x13 [3x]
- 4 Perforated bracket



Mounting bracket

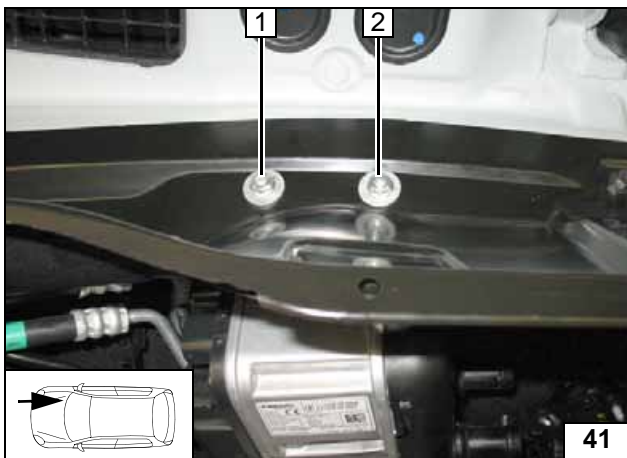

Installing Heater

Insert 15mm shim at position **1** and 5mm shim at position **2** between bracket and coolant reservoir.

- 1 M6x25 bolt, 15mm shim, large diameter washer, flanged nut
- 2 M6x20 bolt, 5mm shim, large diameter washer, flanged nut



Mounting heater

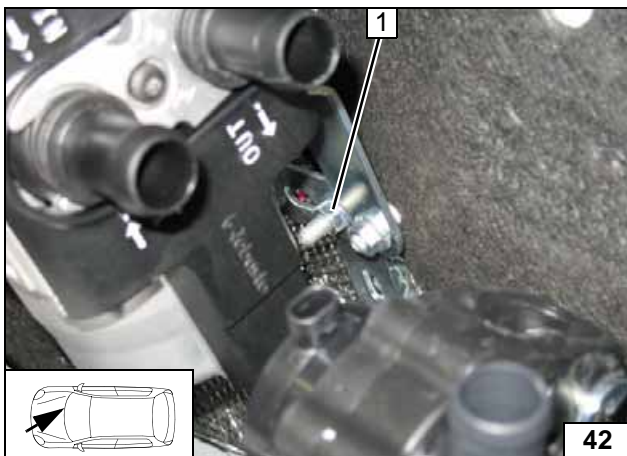

- 1 Flanged nut, premounted bolt

Mounting heater

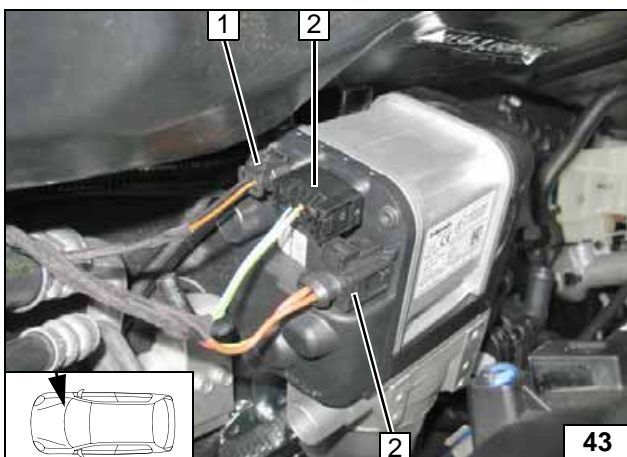

- 1 Connector of circulating pump wiring harness
- 2 Connector of heater wiring harness [2x]

Installing wiring harnesses

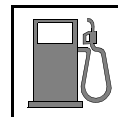

Fuel

CAUTION!

Open the vehicle's fuel tank cap, ventilate the tank and then re-close the tank lock.

Catch any fuel running off in a suitable container.

Install fuel line and metering pump wiring harness so that they are protected against stone impact. Unless specified otherwise, always fasten using cable ties.

Provide rub protection for fuel line and wiring harness in areas where there are sharp edges.

WARNING!

The fuel line and wiring harness are routed to the metering pump as shown in the wiring harness routing diagram.



Connecting heater

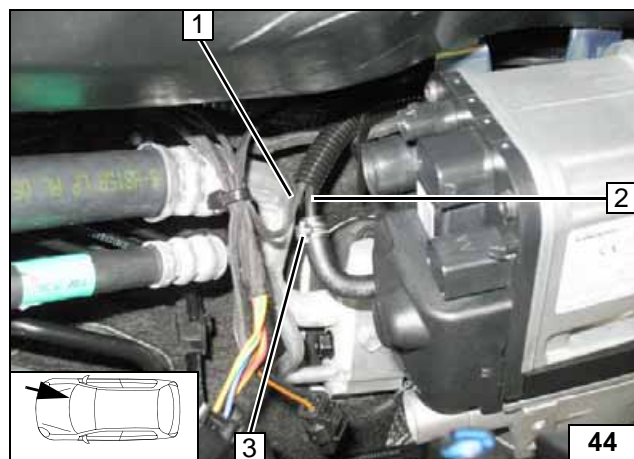

Cut off 500mm from one end of 10mm dia. corrugated tube (will be needed for fuel line of fuel standpipe). Pull fuel line 1 and wiring harness of metering pump 2 into 1600mm long corrugated tube and route to the left side of the vehicle. Wiring harnesses on heater pulled off for better illustration.

3 10 mm dia. clamp

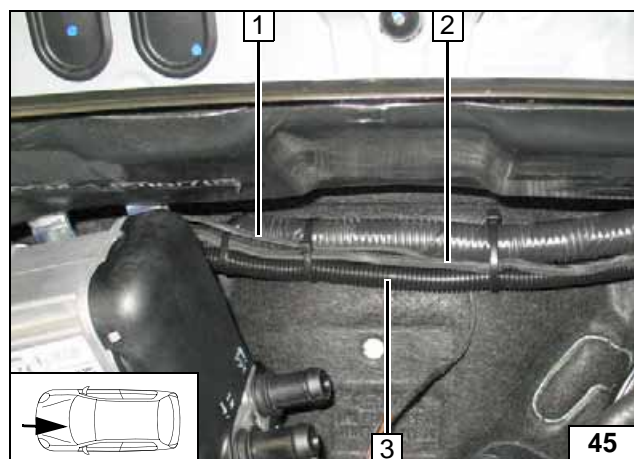

- 1 Wiring harness of circulating pump
- 2 Wiring harness of heater
- 3 Fuel line and wiring harness of metering pump in corrugated tube

Routing lines

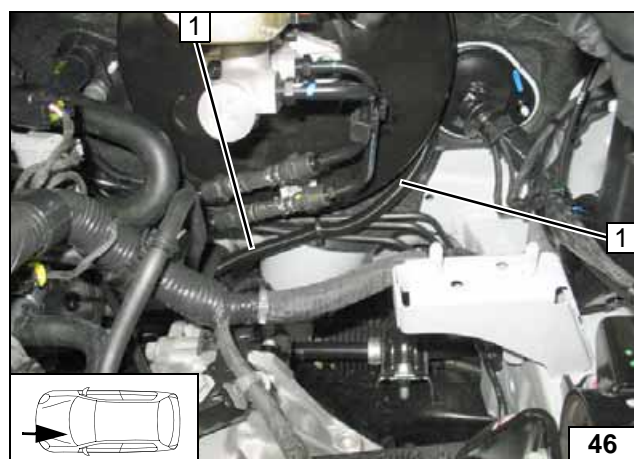

Route fuel line and wiring harness of metering pump in corrugated tube 1 to the underbody along brake lines.



Routing lines

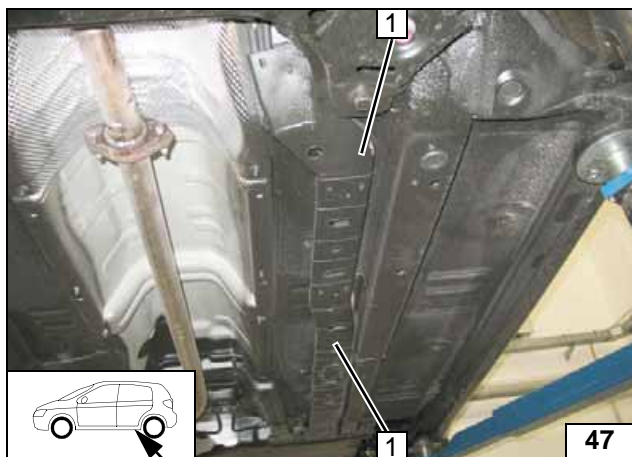
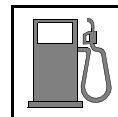

Route fuel line and wiring harness of metering pump in original vehicle line duct to installation location of metering pump.



Routing lines

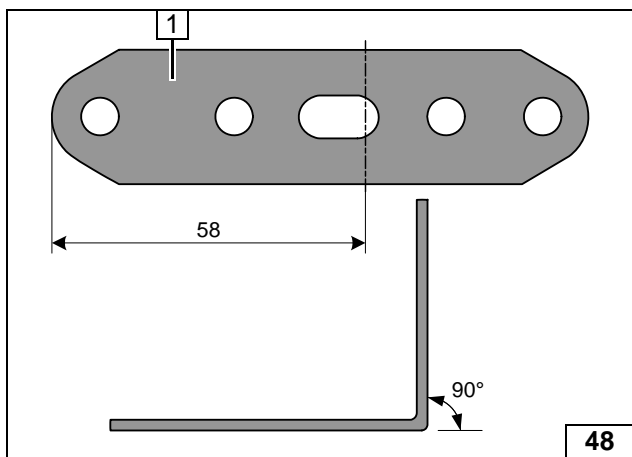

1 Perforated bracket



Preparing perforated bracket

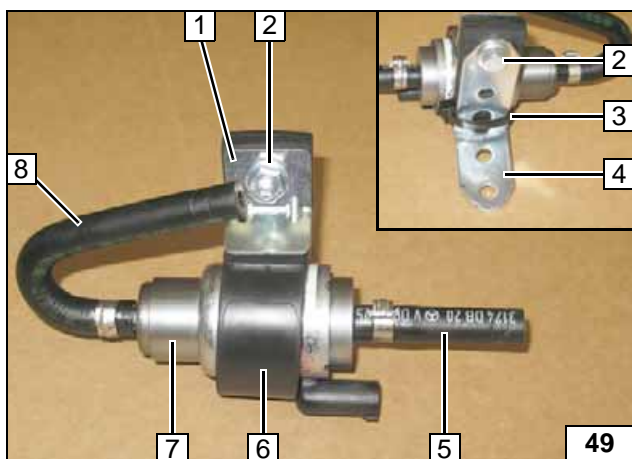

- 1 Support angle bracket
- 2 M6x25 bolt, flanged nut
- 3 Cable tie
- 4 Perforated bracket
- 5 Hose section, 10mm dia. clamp
- 6 Mounting of metering pump
- 7 Metering pump
- 8 180° moulded hose, 10 mm dia. clamp

Premounting metering pump

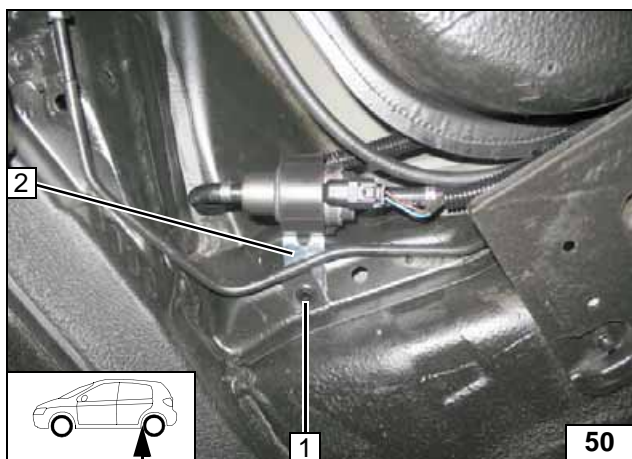

- 1 Original vehicle bolt
- 2 Perforated bracket



Mounting metering pump

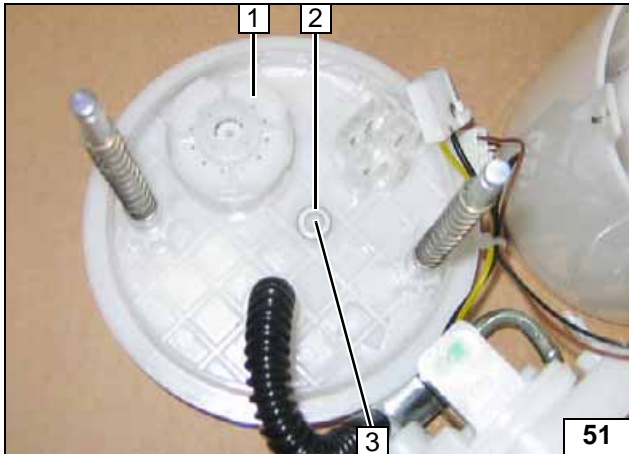
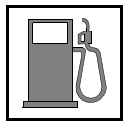

Remove and detach fuel-tank sending unit 1 according to manufacturer's instructions.

- 2 Washer outer dia. $d_a = 11.8 \text{ mm}$
- 3 Copy hole pattern, 6 mm dia. hole



Fuel extraction

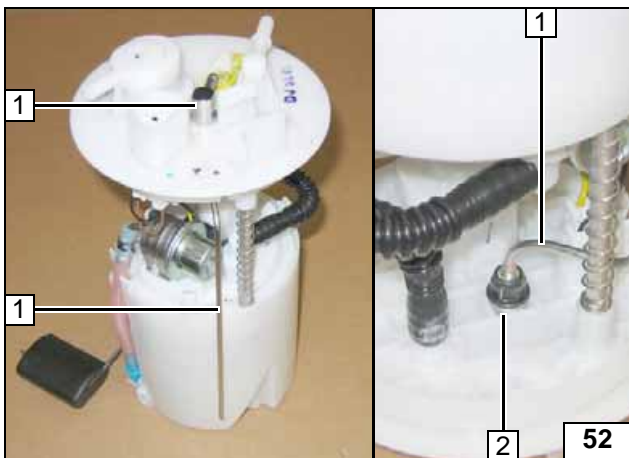

Shape fuel standpipe 1 according to template and cut to length. Insert three washers with outer dia. $d_a = 11.8 \text{ mm}$ as height compensation at position 2.



Mounting fuel standpipe

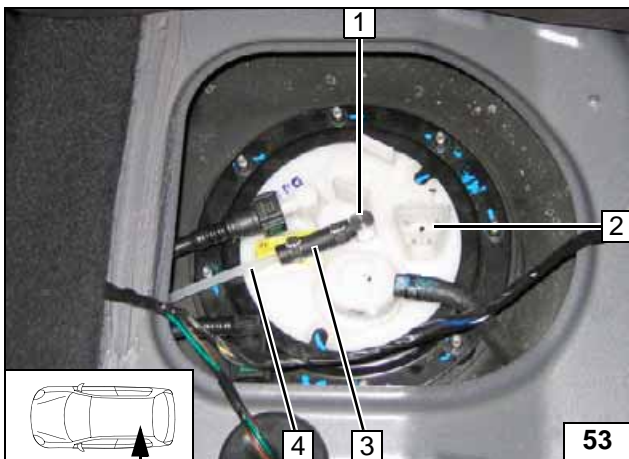

Install fuel-tank sending unit 2 in accordance with manufacturer's instructions.

- 1 Fuel standpipe
- 3 Hose section, 10 mm dia. clamp [2x]
- 4 Fuel line of fuel standpipe



Connecting fuel line

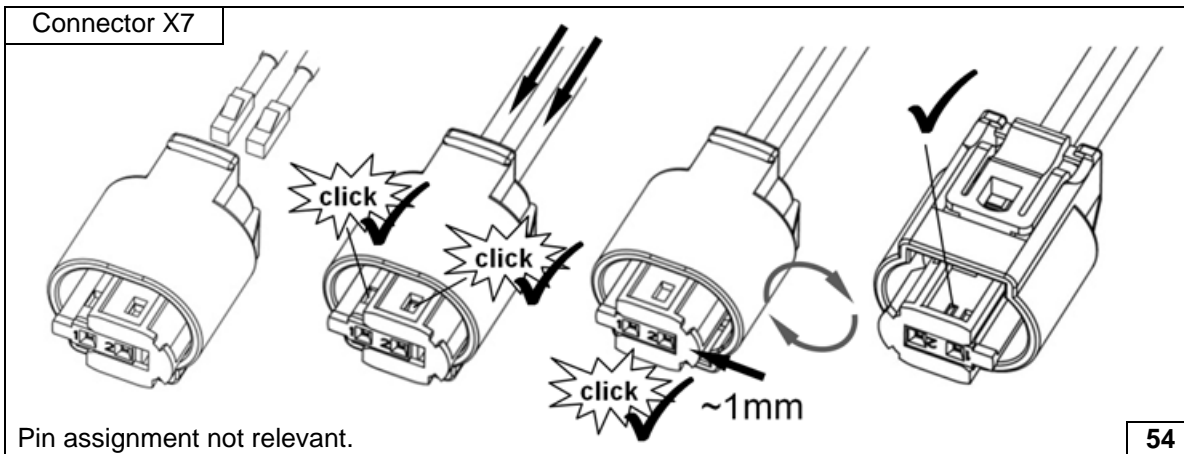

Completing metering pump connector

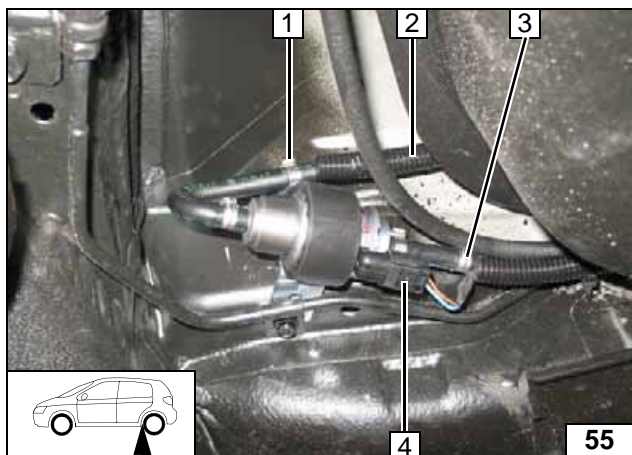
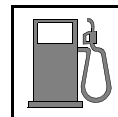

Check the position of the components; adjust if necessary. Check that they have freedom of movement.



- 1 Fuel line of fuel standpipe, 10mm dia. clamp
- 2 Fuel line of fuel standpipe in 500mm long corrugated tube
- 3 Fuel line of heater, 10mm dia. clamp
- 2 Wiring harness of metering pump, connector mounted

Connect- ing meter- ing pump

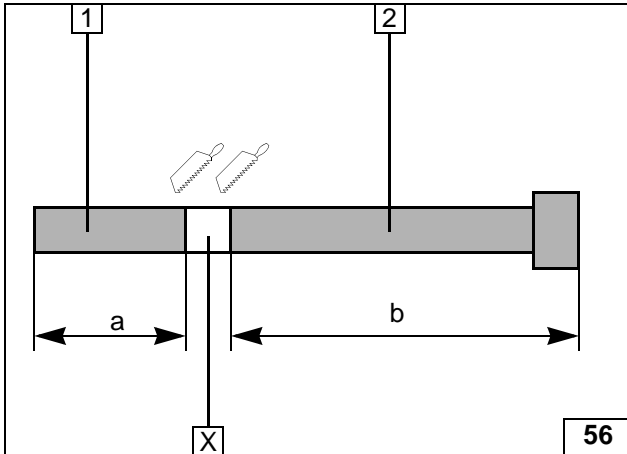
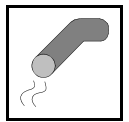

Exhaust Gas

Discard section X.

- 1 Exhaust pipe
a = 280
- 2 Exhaust end section
b = 620



Preparing exhaust pipe

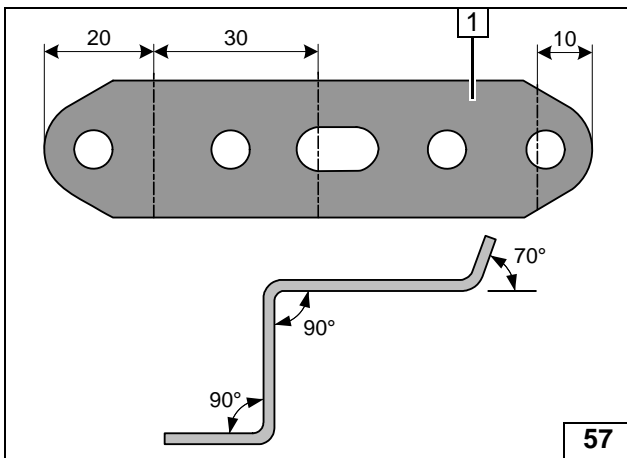

- 1 Perforated bracket



Bending perforated bracket

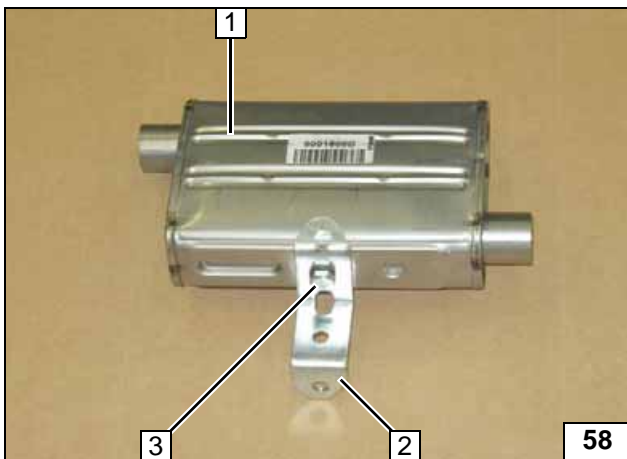

- 1 Silencer
- 2 Perforated bracket
- 3 M6x16 bolt, spring lockwasher

Premounting silencer



- 1 M6x20 bolt, spring lockwasher, existing threaded hole
- 2 Perforated bracket

Mounting silencer

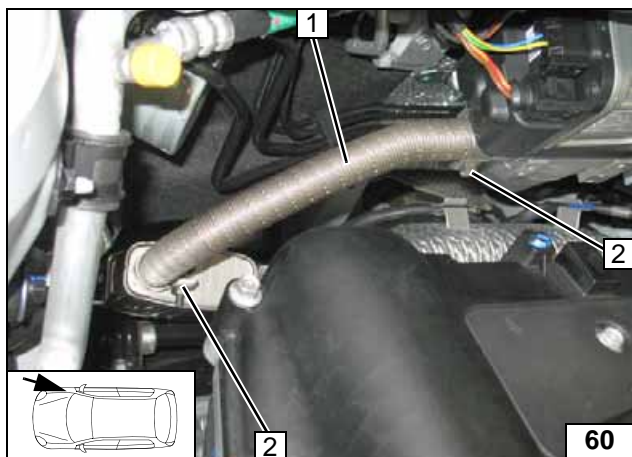
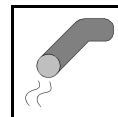

- 1 Exhaust pipe
- 2 Hose clamp [2x]

Mounting exhaust pipe

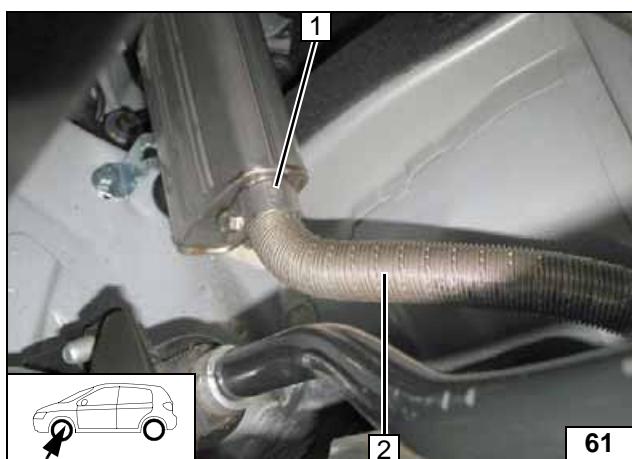

- 1 Hose clamp
- 2 Exhaust end section

Mounting exhaust end section

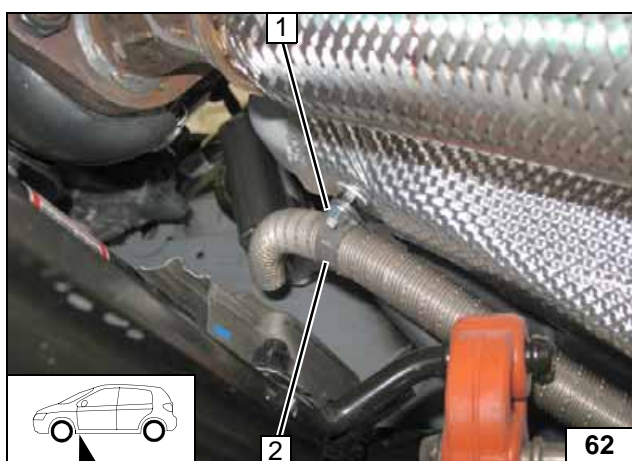

- 1 M6 flanged nut, original vehicle stud bolt
- 2 P-clamp

Fastening exhaust end section

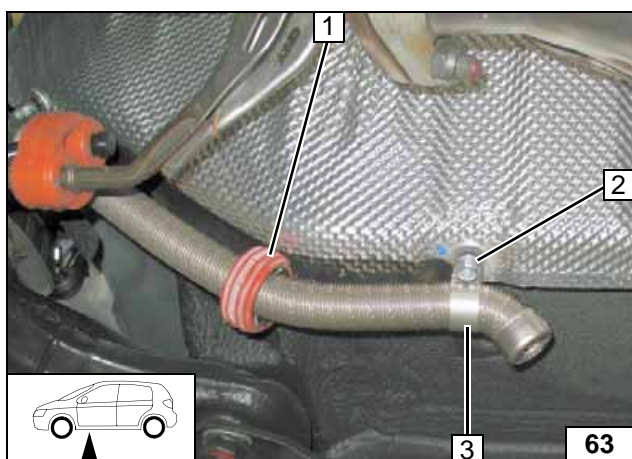

Push spacer bracket 1 onto exhaust end section and align. Ensure sufficient distance from neighbouring components, adjust if necessary.

- 2 M6 flanged nut, original vehicle stud bolt
- 3 P-clamp

Fastening exhaust end section



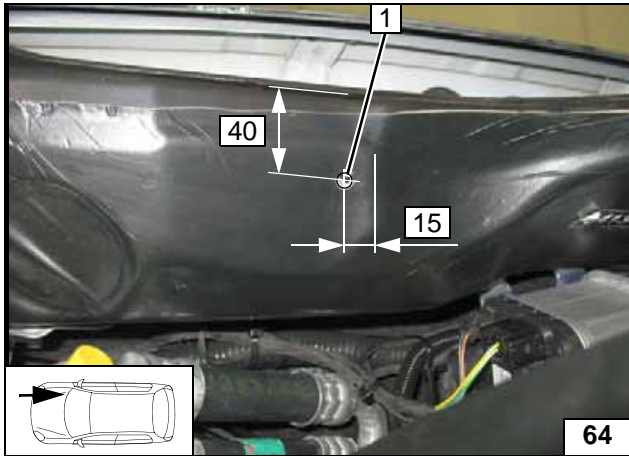
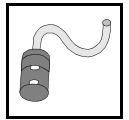

Combustion Air

- 1 5.5mm dia. hole

**Hole for si-
lencer**

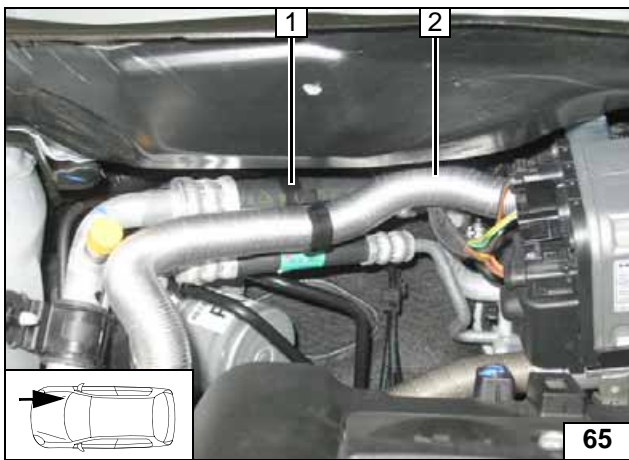

- 1 Hose bracket
- 2 Combustion air pipe



**Mounting combus-
tion air pipe**

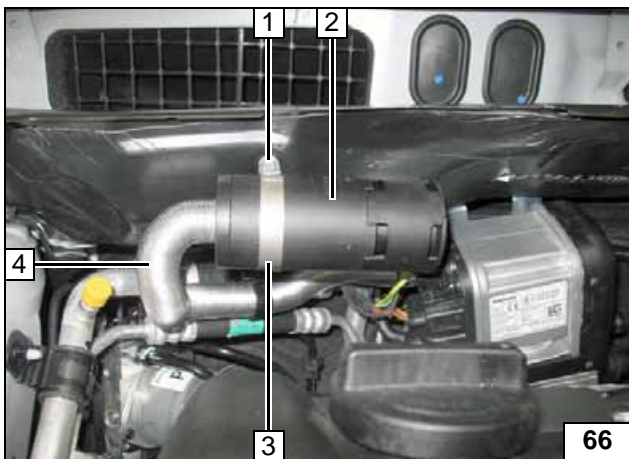

- 1 M5x16 bolt, flanged nut
- 2 Silencer
- 3 51 mm dia. clamp
- 4 Combustion air pipe



**Mounting
silencer**





Coolant Circuit

WARNING!

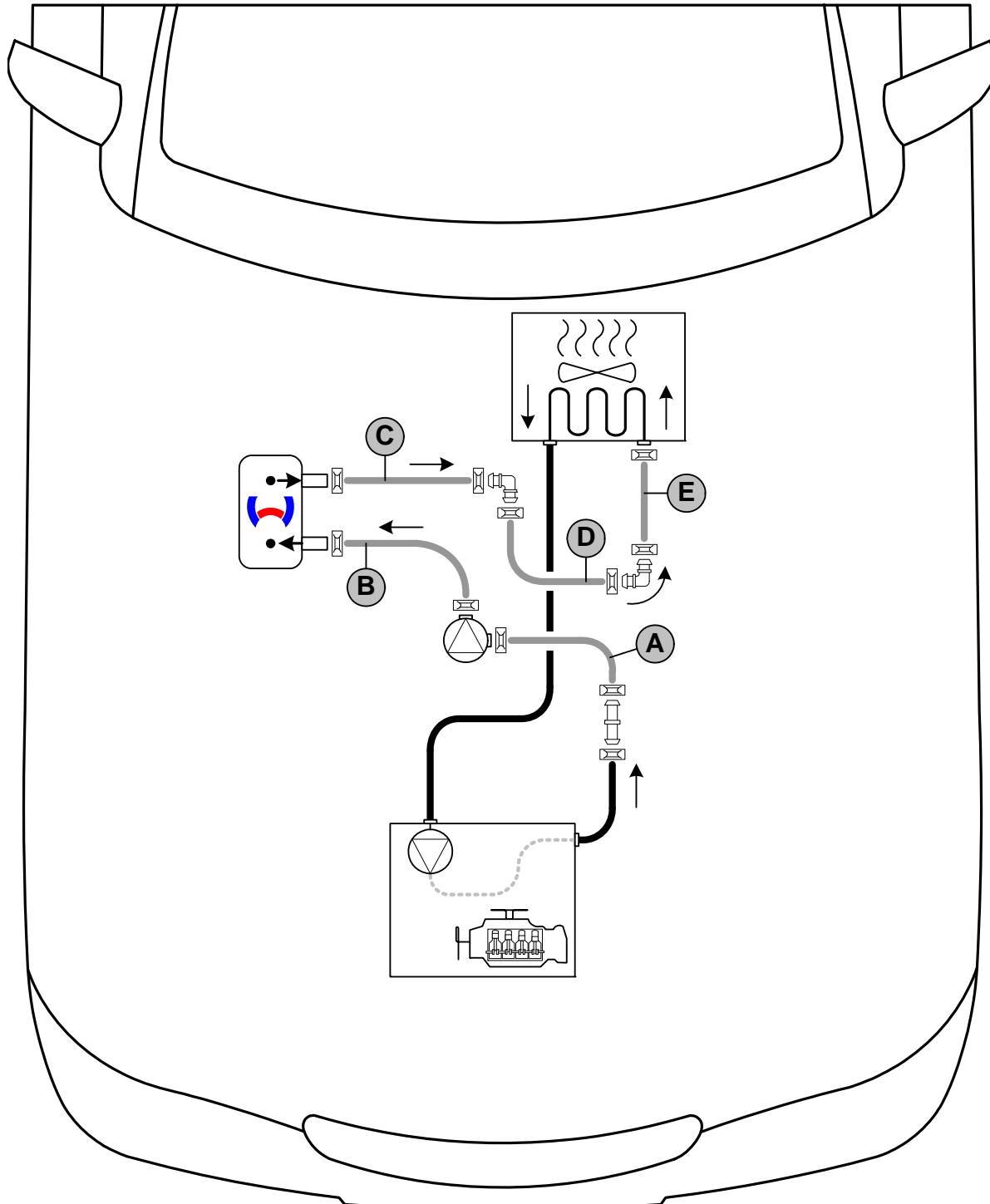
Any coolant running off should be collected using a suitable container. Install hoses so that they are kink-free. Unless specified otherwise, always fasten using cable ties. Position the clamps so that other hoses cannot be damaged. The heater must be filled with coolant when installing the hoses. The connection should be modelled on an "inline" circuit and based on the following diagram:



Hose installation diagram

All spring clips  = 25 mm dia.
 All connecting pipes  and  = 18x18 mm dia.



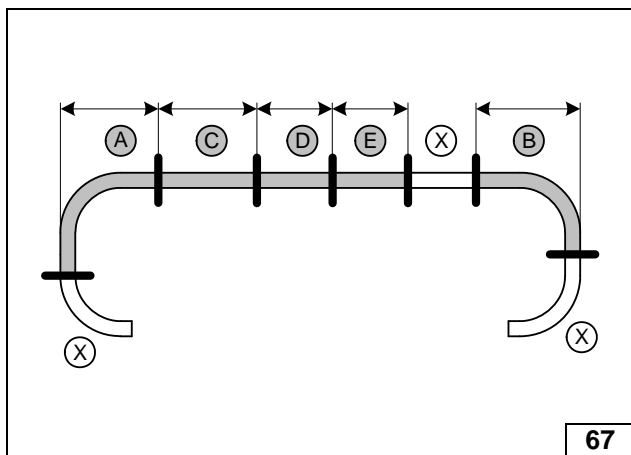

Discard section X.

1.2 P	1.4 P
A = 70	A = 170
B = 120	B = 120
C = 130	C = 130
D = 110	D = 110
E = 110	E = 110



Cutting hoses to length

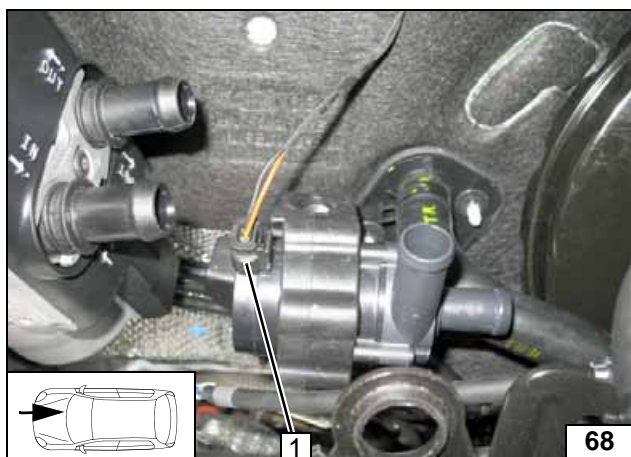

1 Install connector of circulating pump wiring harness

Connect-
ing circu-
lating
pump

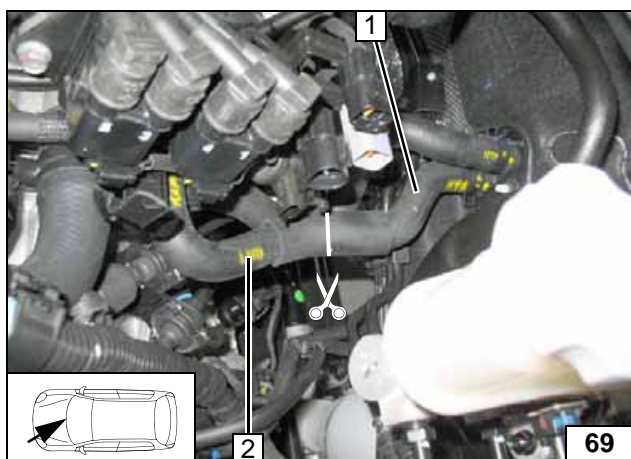

1.2 P

Remove insulation in the area of the cutting point. Cut off hose on engine outlet/heat exchanger inlet at marking. Remove and discard hose section of heat exchanger inlet 1 and spring clip.



Cutting
point

2 Engine outlet hose section

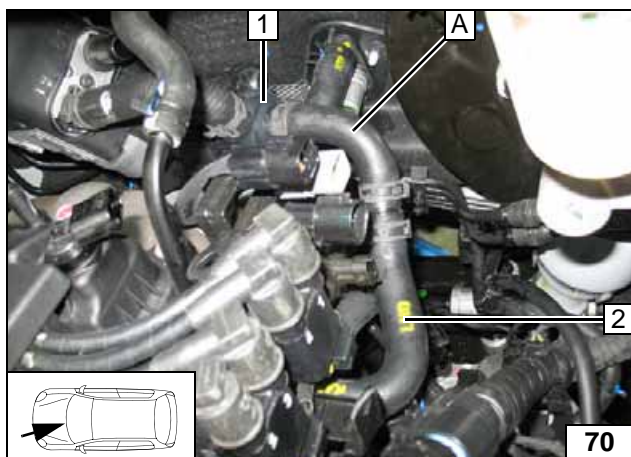

1 Circulating pump
2 Hose of engine outlet

Connect-
ing engine
outlet

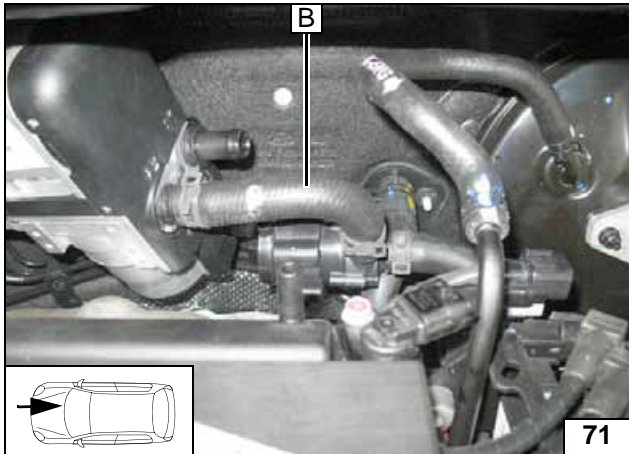

Connect-
ing heater
inlet

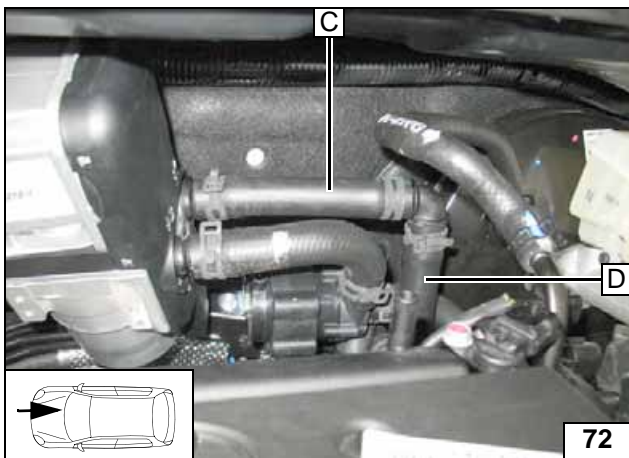

Connect-
ing heater

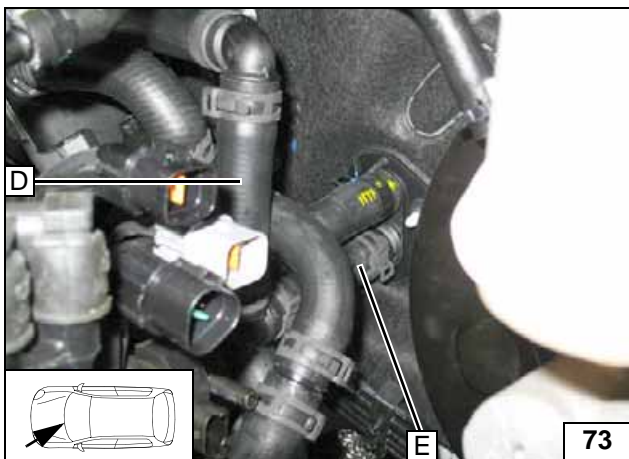

Align hoses. Ensure sufficient distance from neighbouring components, adjust if necessary.



Connect-
ing heat ex-
changer
inlet

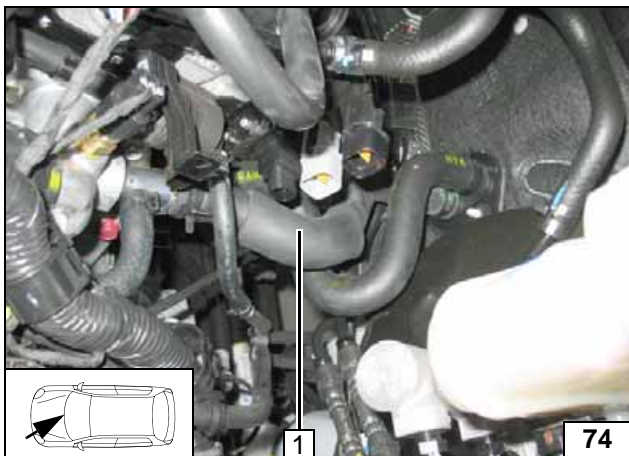

1.4 P

Remove and discard hose of engine outlet / heat exchanger inlet 1 with spring clips.



Cutting
point



1 Circulating pump

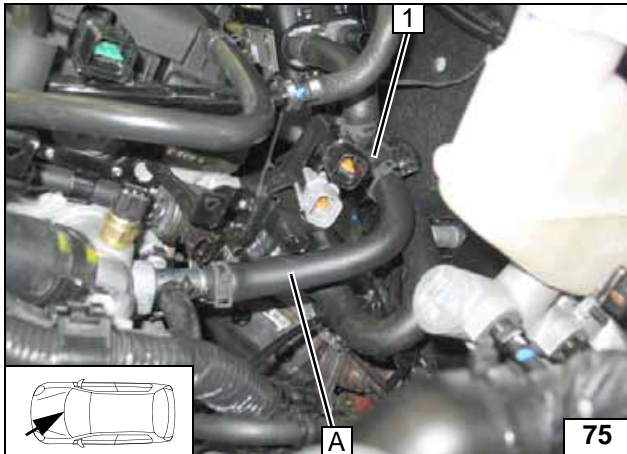

Connect-
ing engine
outlet

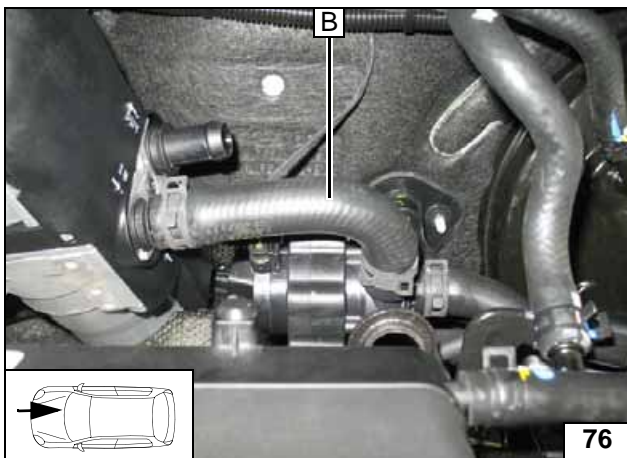

Connect-
ing heater
inlet

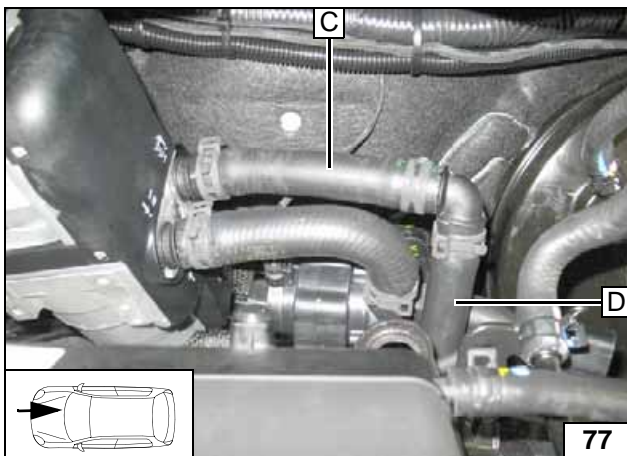

Connect-
ing heater
outlet

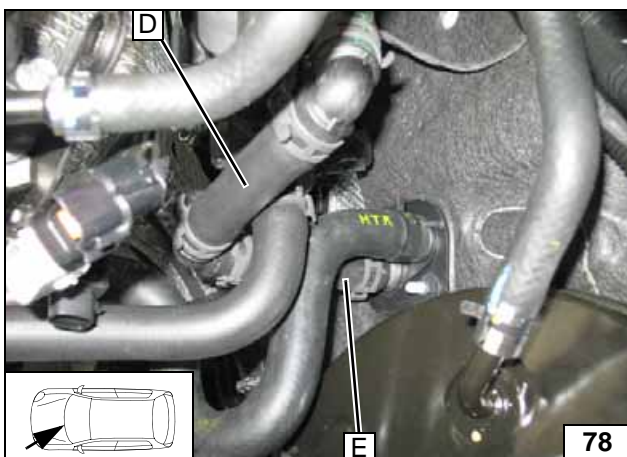

Align hoses. Ensure sufficient distance from neighbouring components, adjust if necessary.



Connect-
ing heat ex-
changer
inlet



Final Work

WARNING!

Reassemble the components in reverse order. Check all hoses, clamps and all electrical connections for firm seating. Insulate and tie back all loose lines.

Only use manufacturer-approved coolant. Spray the heater components with anti-corrosion wax (Tectyl 100K, Order No. 111329).



- **Connect the battery**
- **Fill and bleed the coolant circuit according to the vehicle manufacturer's specifications.**
- **Set digital timer, teach telestart transmitter**
- **Make settings on A/C control panel according to the "Operating Instructions for End Customer".**
- **Place the "Switch off parking heater before refueling" caution label near the filler neck**
- **See installation instructions for initial start-up and function check**

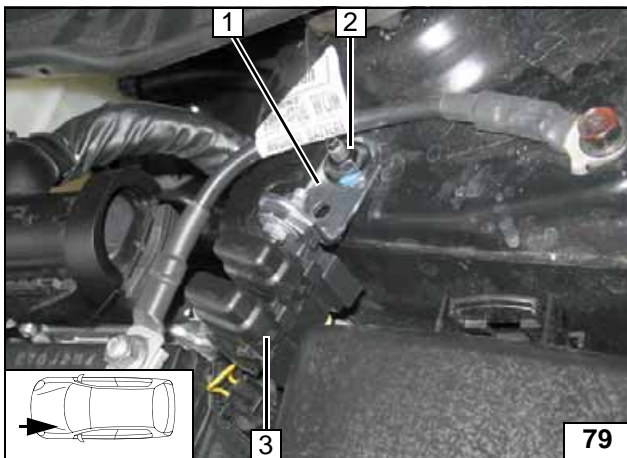

- 1 Angle bracket
- 2 Original vehicle stud bolt, original vehicle flanged nut
- 3 Fuses F1-2

**Fastening
engine
compartment
fuse
holder**

Webasto Thermo & Comfort SE
Postfach 1410
82199 Gilching
Germany
Internet: www.webasto.com
Technical Extranet:
<http://dealers.webasto.com>

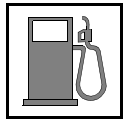

Template for Fuel Standpipe

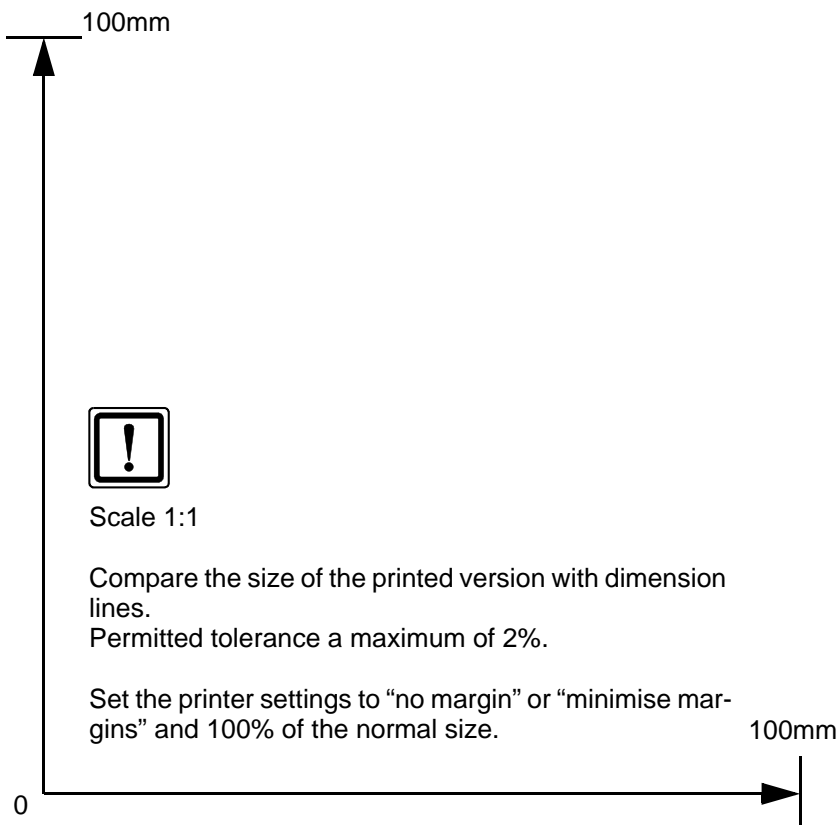



Template for Bracket

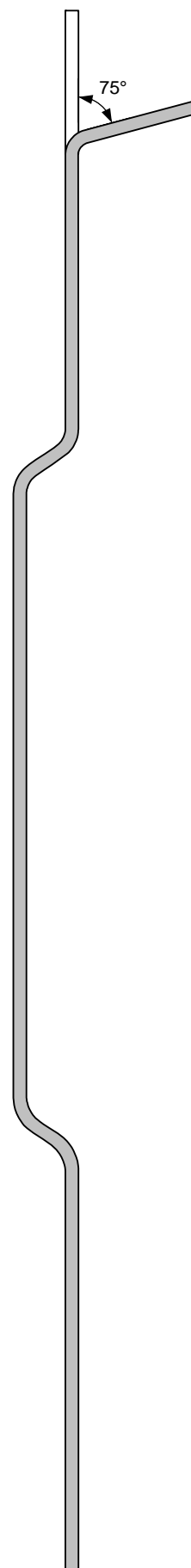
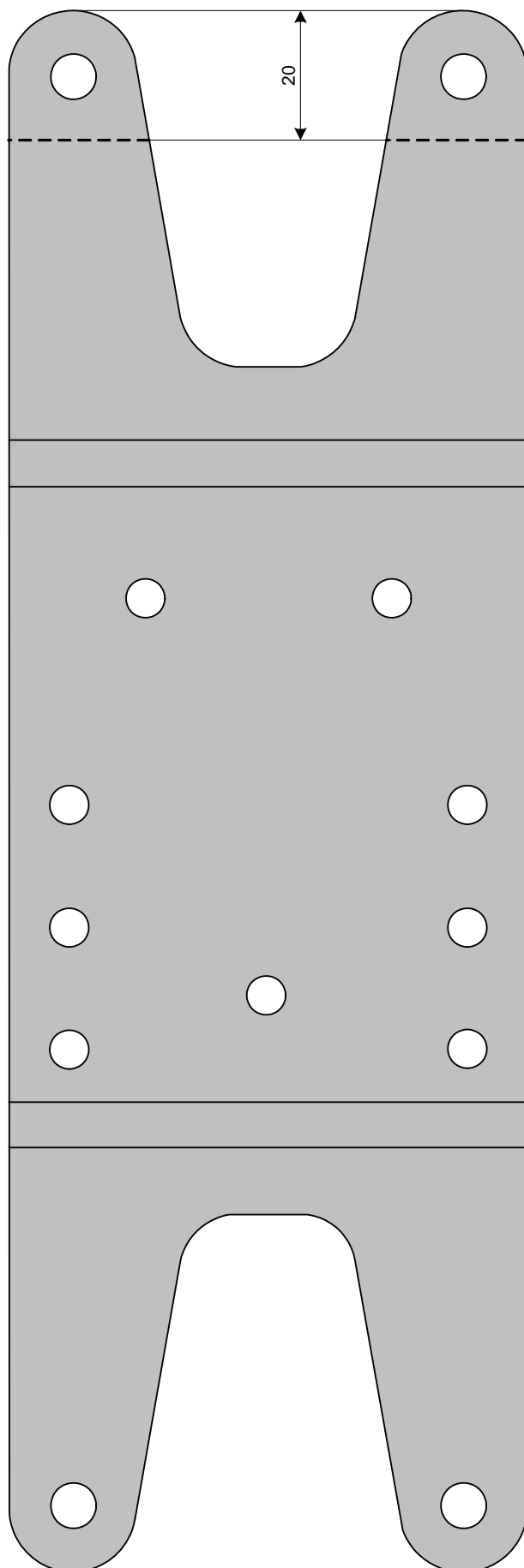

Operating Instructions for Manual A/C System

Please remove page and add to the vehicle operating instructions.

Note:

We recommend matching the heating time to the driving time.

Heating time = driving time

Example:

For a driving time of approx. 20 min. (in one direction), we recommend not exceeding a switch-on time of 20 min.

If the vehicle has passenger compartment monitoring this must be deactivated in addition to the vehicle settings for the heating operation.

Instructions for de-activation may be obtained from the operating instructions of the vehicle.

Before parking the vehicle, make the following settings:



- 1 Set fan to level "1", max. "2"
- 2 Air outlet to windscreen
- 3 Set temperature to "max."

A/C control panel

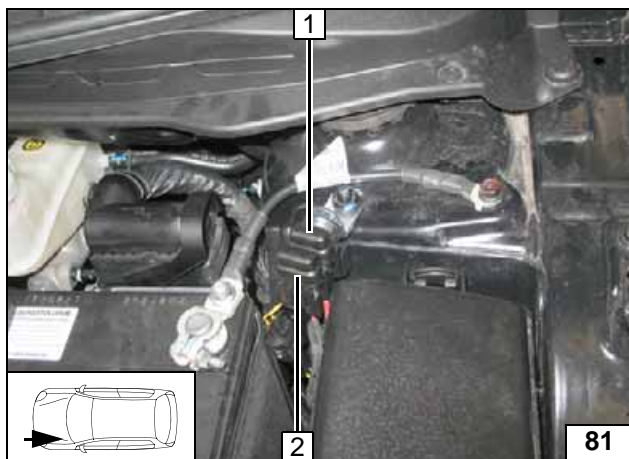

- 1 30A main fuse F2 of passenger compartment
- 2 20A heater fuse F1

Engine compartment fuses

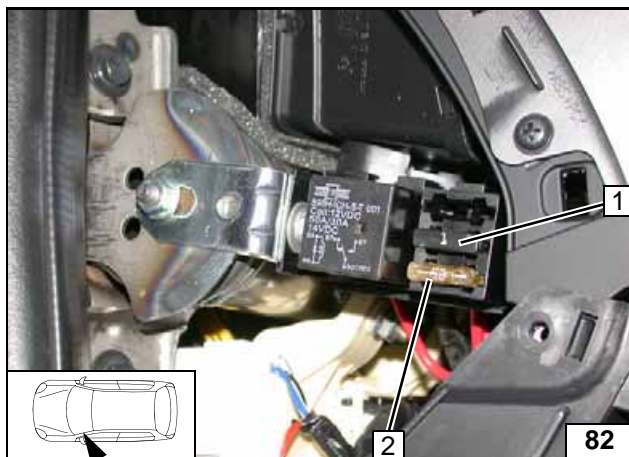

- 1 1A fuse F3 of heater control
- 2 25A fan fuse F4

Passenger compartment fuses



Operating Instructions for Automatic Air-Conditioning

Please remove page and add to the vehicle operating instructions.

Note:

We recommend matching the heating time to the driving time.
Heating time = driving time

Example:

For a driving time of approx. 20 min. (in one direction), we recommend not exceeding a switch-on time of 20 min.

If the vehicle has passenger compartment monitoring this must be deactivated in addition to the vehicle settings for the heating operation.

Instructions for de-activation may be obtained from the operating instructions of the vehicle.

Before parking the vehicle, make the following settings:



- 1 Air outlet set "upward"
- 2 Set fan to level "2", max. "3"
- 3 Set temperature to "HI"



A/C control panel

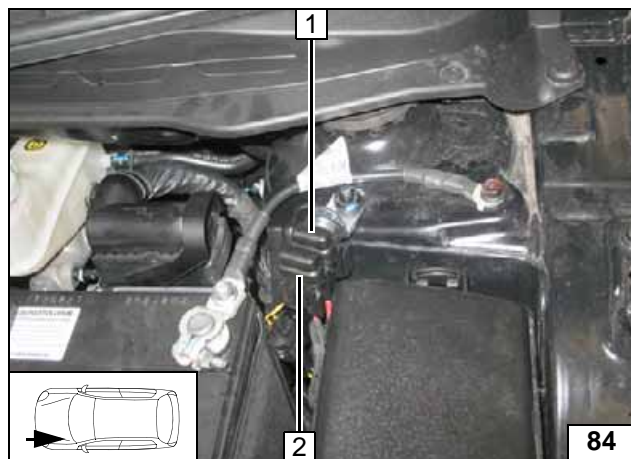

- 1 30A main fuse F2 of passenger compartment
- 2 20A heater fuse F1

Engine compartment fuses

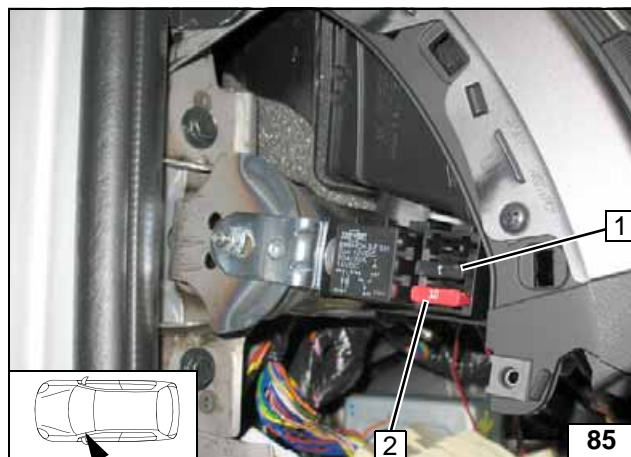

- 1 1A fuse F3 of heater control
- 2 10A fan fuse F4

Passenger compartment fuses