

Water Heater

Thermo Top Evo Parking Heater



Installation Documentation

Citroen Berlingo / Peugeot Partner

Validity

Manufacturer	Model	Type	EG BE No. / ABE
Citroen	Berlingo	7	e2 * 2001 / 116 * 0366 * ...

Motorisation	Fuel	Transmission type	Output in kW	Displacement in cm ³	Engine code
1.6	Diesel (HDI 90)	5-gear SG	68	1560	9HP
1.6	Diesel (eHDI 90)	EGS 6	68	1560	9HP
1.6	Diesel (Blue HDI)	5-gear SG	73	1560	BH02
1.6	Diesel (Blue HDI)	5-gear SG	88	1560	BH01

SG = manual transmission

EGS 6 = electronically controlled 6-gear transmission

From model year 2012

Left-hand drive vehicle

Verified equipment variants: Manual / automatic air-conditioning system
 Front fog lights
 Stop / start

Manufacturer	Model	Type	EG BE No. / ABE
Peugeot	Partner	7	e2 * 2001 / 116 * 0365 * ...

Motorisation	Fuel	Transmission type	Output in kW	Displacement in cm ³	Engine code
1.6	Diesel (eHDI 92)	5-gear SG	68	1560	9H06
1.6	Diesel (eHDI 92)	EGS 6	68	1560	9H06
1.6	Diesel (Blue HDI)	5-gear SG	73	1560	BH02
1.6	Diesel (Blue HDI)	5-gear SG	88	1560	BH01

SG = manual transmission

EGS 6 = Electronically controlled 6-gear transmission

From model year 2014

Left-hand drive vehicle

Verified equipment variants: Manual air-conditioning
 Automatic air-conditioning (88 kW)
 Front fog lights
 LED daytime running lights
 Stop / start

Total installation time: approx. 7 hours
 approx. 8 hours in case of 73/88 kW

Citroen Berlingo / Peugeot Partner

Table of Contents

Validity	1	Preparing Installation Location	19
Necessary Components	2	Preparing Heater	22
Installation Overview	2	Combustion Air	26
Information on Total Installation Time	2	Fuel	27
Information on Operating and Installation Instructions	3	Coolant Circuit	32
Information on Validity	4	Exhaust Gas	37
Technical Information	4	Final Work	40
Explanatory Notes on Document	4	Fuel Standpipe Template	41
Preliminary Work	5	Operation of Manual A/C for Citroen	42
Heater Installation Location	5	Operation of Automatic A/C for Citroen	43
Preparing Electrical System	6	Operation of Manual A/C for Peugeot	44
Electrical System	10	Operation of Automatic A/C for Peugeot	45
Manual Air-Conditioning Fan Controller	11		
Automatic Air-Conditioning Fan Controller	14		
MultiControl CAR Option	17		
Remote Option (Telestart)	17		
ThermoCall Option	18		

Necessary Components

- Basic delivery scope of *Thermo Top Evo* according to price list
- Installation kit for Citroen Berlingo / Peugeot Partner 2012 Diesel: **1318864C**
- To be ordered additionally in case of automatic air-conditioning:
Additional kit AAC Citroen Berlingo 1.6 eHDI: **1318866B**
- To be ordered additionally in case of 73/88 kW:
Additional kit for fuel standpipe: **1324611A**
- Heater control in accordance with price list and upon consultation with end customer
- In case of Telestart, indicator lamp in accordance with price list and in consultation with end customer

Installation instructions:

- Arrange for the vehicle to be delivered with the tank only about ¼ full.
- The installation location of the push button in case of Telestart or Thermo Call should be confirmed with the end customer.
- Depending on the space required and the vehicle manufacturer's instructions, we recommend the use of a vehicle battery with a higher electrical capacity.

Installation Overview

Legend:

1. Heater
2. Engine compartment fuse holder
3. Passenger compartment relay and fuse holder
4. Circulating pump
5. PWM Gateway (only in case of automatic air-conditioning)
6. MultiControl CAR
7. Metering pump

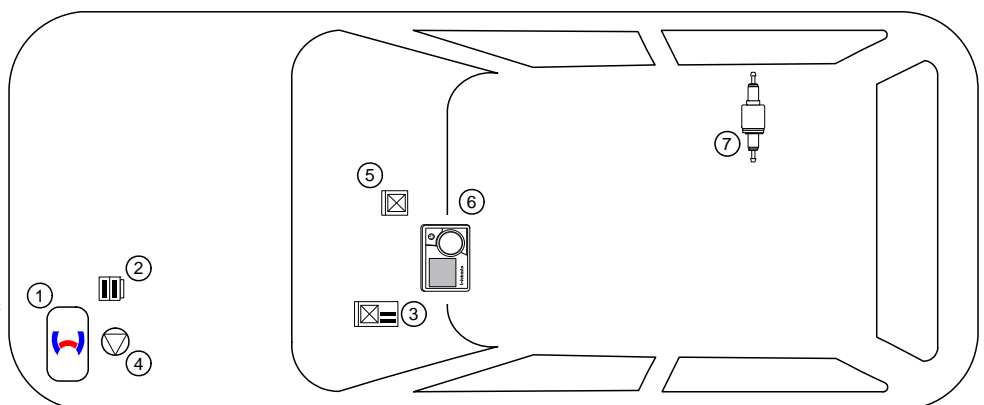

Information on Total Installation Time

The total installation time includes the time needed for mounting and demounting the vehicle-specific components, the heater specific installation time and all other times required for the system integration and initial start-up of the heater.

The total installation time may vary for vehicle equipment other than provided.

Information on Operating and Installation Instructions

1 Important information (not complete)

1.1 Installation and repair



The improper installation or repair of Webasto heating and cooling systems can cause fire or the leakage of deadly carbon monoxide, leading to serious injury or death.



To install and repair Webasto heating and cooling systems you need to have completed a special company training course and have the appropriate technical documentation, special tools and special equipment.



Installation and repair may ONLY be carried out by persons trained and certified in a Webasto training course. NEVER try to install or repair Webasto heating or cooling systems if you have not completed a Webasto training course, you do not have the necessary technical skills and you do not have the technical documentation, tools and equipment available to ensure that you can complete the installation and repair work properly.

Only use genuine Webasto parts. See the Webasto air and water heaters accessories catalogue for this purpose.

1.2 Operation

To ensure safe operation, we recommend having the heater checked every two years by an authorised Webasto dealer, especially when used over a long period and/or under extreme environmental conditions.

Do not operate the heater in closed rooms due to the danger of poisoning and suffocation.

Always switch off the heater before refuelling.

The heater may only be used with the prescribed fuel diesel (DIN EN 590) or petrol (DIN EN 228).

The heater may not be cleaned with a high-pressure cleaner.

1.3 Please note

ALWAYS follow all Webasto installation and operating instructions and observe all warnings.

To become familiar with and understand all functions and properties of the heater, the operating instructions must be read carefully and observed at all times.

For proper, safe installation and repair work, the installation instructions with all warnings and safety information must be carefully read and observed at all times. Please always contact a workshop authorised by Webasto for all installation and repair work.

Important

Webasto shall assume no liability for defects, damage and injuries resulting from a failure to observe the installation, repair and operating instructions of the information contained in them.

This liability exclusion particularly applies to improper installations and repairs, installations and repairs by untrained persons or in the case of a failure to use genuine spare parts.

The liability due to culpable disregard to life, limb or health and due to damage or injuries caused by a wilful or reckless breach of duty remain unaffected, as does the obligatory product liability.

Installation should be carried out according to the general, standard rules of technology. Unless specified otherwise, fasten hoses, lines and wiring harnesses to original vehicle lines and wiring harnesses using cable ties. Insulate loose wire ends and tie back. Connectors on electronic components must audibly snap into place during assembly.

Sharp edges should be fitted with rub protection. Spray unfinished body areas, e.g. drilled holes, with anti-corrosion wax (Tectyl 100K).

Observe the instructions and guidelines of the respective vehicle manufacturer for demounting and mounting vehicle specific components!

The initial startup is to be executed with the Webasto Thermo Test Diagnosis.

When installing a programmable control module (e.g. a PWM Gateway), the corresponding settings must be checked or adjusted.

2 Statutory regulations governing installation

Guidelines	Thermo Top Evo
Heating Directive ECE R122	E1 00 0258
EMC Directive ECE R10	E1 04 5627

Note

The regulations of these guidelines are binding in the scope of the Directive 70/156/EEC and/or 2007/46/EC (for new vehicle models from 29/04/2009) and should also be observed in countries in which there are no special regulations.

Important

Failure to follow the installation instructions will result in the invalidation of the type approval for the heater and therefore invalidation of the general **homologation of the vehicle**.

Note

The heater is licensed in accordance with paragraph 19, section 3, No. 2b of the StVZO (German Road Traffic Licensing Authority).

2.1 Excerpt from ECE regulation 122 (heating system) paragraph 5 for the installation of the heater

Beginning of excerpt.

ANNEX VII

REQUIREMENTS FOR COMBUSTION HEATERS AND THEIR INSTALLATION

1. GENERAL REQUIREMENTS

1.7.1. A clearly visible tell-tale in the operator's field of view shall inform when the combustion heater is switched on or off.

2. VEHICLE INSTALLATION REQUIREMENTS

2.1. Scope

2.1.1. Subject to paragraph 2.1.2. combustion heaters shall be installed according to the requirements of this Annex.

2.1.2. Vehicles of category O having liquid fuel heaters are deemed to comply with the requirements of this Annex.

2.2. Positioning of heater

2.2.1. Body sections and any other components in the vicinity of the heater must be protected from excessive heat and the possibility of fuel or oil contamination.

2.2.2. The combustion heater shall not constitute a risk of fire, even in the case of overheating. This requirement shall be deemed to be fulfilled if the installation ensures an adequate distance to all parts and suitable ventilation, by the use of fire resistant materials or by the use of heat shields.

2.2.3. In the case of M2 and M3 vehicles, the heater must not be positioned in the passenger compartment. However, an installation in an effectively sealed envelope which also complies with the conditions in paragraph 2.2.2 may be used.

2.2.4. The label referred to in paragraph 1.4 or a duplicate, must be positioned so that it can be easily read when the heater is installed in the vehicle.

2.2.5. Every reasonable precaution should be taken in positioning the heater to minimise the risk of injury and damage to personal property.

2.3. Fuel supply

2.3.1. The fuel filler must not be situated in the passenger compartment and must be provided with an effective cap to prevent fuel spillage.

2.3.2. In the case of liquid fuel heaters, where a supply separate to that of the vehicle is provided, the type of fuel and its filler point must be clearly labelled.

2.3.3. A notice, indicating that the heater must be shut down before refuelling, must be affixed to the fuelling point. In addition a suitable instruction must be included in the manufacturer's operating manual.

2.4. Exhaust system

2.4.1. The exhaust outlet must be located so as to prevent emissions from entering the vehicle through ventilators, heated air inlets or opening windows.

2.5. Combustion air inlet

2.5.1. The air for the combustion chamber of the heater must not be drawn from the passenger compartment of the vehicle.

2.5.2. The air inlet must be so positioned or guarded that blocking by rubbish or luggage is unlikely.

2.6. Heating air inlet

2.6.1. The heating air supply may be fresh or recirculated air and must be drawn from a clean area not likely to be contaminated by exhaust fumes emitted either by the propulsion engine, the combustion heater or any other vehicle source.

2.6.2. The inlet duct must be protected by mesh or other suitable means.

2.7. Heating air outlet

2.7.1. Any ducting used to route the hot air through the vehicle must be so positioned or protected that no injury or damage could be caused if it were to be touched.

2.7.2. The air outlet must be so positioned or guarded that blocking by rubbish or luggage is unlikely.

End of excerpt.

In multilingual versions the German language is binding.

Citroen Berlingo / Peugeot Partner

Information on Validity

This installation documentation applies to Citroen Berlingo diesel vehicles from model year 2012 and later as well as Peugeot Partner vehicles from model year 2014 and later - for validity see page 1 -, assuming technical modifications to the vehicle do not affect installation, any liability claims excluded. Depending on the vehicle version and equipment, modifications may be necessary during installation with respect to this installation documentation.

Vehicle and engine types, equipment variants and other specifications not listed in this installation documentation have not been tested. However, installation according to this installation documentation may be possible.

Technical Information

Special Tools

- Hose clamp pliers for auto-tightening hose clamps
- Hose clamp pliers for Clic hose clamps of type W
- Automatic wire stripper 0.2 - 6mm²
- Crimping pliers for cable lug / tab connector 0.5 - 6mm²
- Torque wrench for 2.0 - 10 Nm
- Hose clamping pliers
- Metric thread-setter kit
- Deep-hole marker
- Webasto Thermo Test Diagnosis with current software

Dimensions

- All dimensions are in mm.













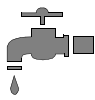

Tightening torque values

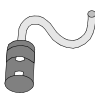
- Tightening torque values of 5x13 heater bolts and heater stud bolts = 8Nm
- Tightening torque value of 5x15 water connection piece retaining plate bolt = 7Nm.
- Tighten other bolt connections in accordance with manufacturer's instructions or in accordance with state-of-the-art-technology.

Explanatory Notes on Document

You will find an identification mark on the outside top right corner of the page in question to provide you with a quick overview of the individual working steps.

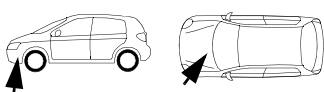
Special features are highlighted using the following symbols:

Mechanical System		Specific risk of injury or fatal accidents.	
Electrical System		Specific risk due to electrical voltage.	
Coolant Circuit		Specific risk of damage to components.	
Combustion Air		Specific risk of fire and explosion.	
Fuel		Reference to general installation instructions of the Webasto components or to the manufacturer's vehicle-specific documents.	
Exhaust Gas		Reference to a special technical feature.	
Software		The arrow in the vehicle icon indicates the position on the vehicle and the viewing angle.	
		Tightening torque according to the manufacturer's vehicle-specific documents.	

Citroen Berlingo / Peugeot Partner

Preliminary Work

Vehicle

- Open the fuel tank cap.
- Ventilate the fuel tank.
- Close the fuel tank cap again.
- Depressurise the cooling system.
- Disconnect the battery.
- Completely remove the battery together with the carrier.
- Remove the air intake hose (73/88 kW).
- Remove the bracket of the air intake hose (73/88 kW).
- Remove the lower and left instrument panel trim on the driver's side.
- Remove the knee airbag (if present).
- Remove the underride protection.
- Lower the fuel tank in accordance with the manufacturer's instructions (73/88 kW).
- Detach the front section of the left front wheel well trim.
- Remove the rear left wheel and wheel well trim (73/88 kW).
- Remove the glove box.
- Remove the footwell trim on the driver's and front passenger's sides.

Heater

- Remove years that do not apply from the type and duplicate label.
- Attach the duplicate label (type label) visibly in the appropriate place in the engine compartment.



Heater Installation Location

- 1 Heater

Installation
location

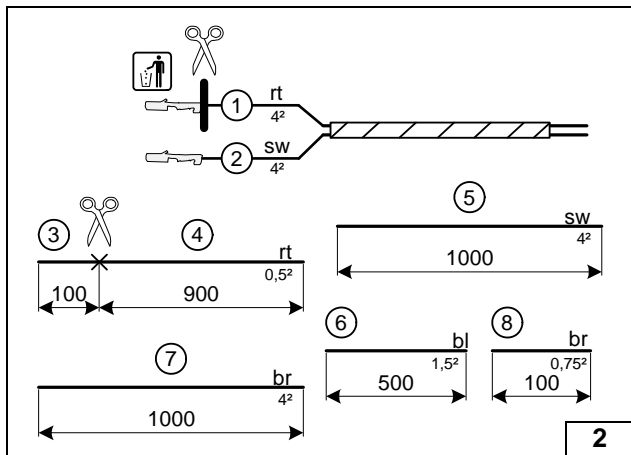

Preparing Electrical System

Wire sections retain their numbering in the entire document.

Produce all following electrical connections as shown in the wiring diagram.

Manual air-conditioning

- ① Red (rt) wire of fan wiring harness
- ② Black (sw) wire of fan wiring harness



Cutting to length / assigning wires

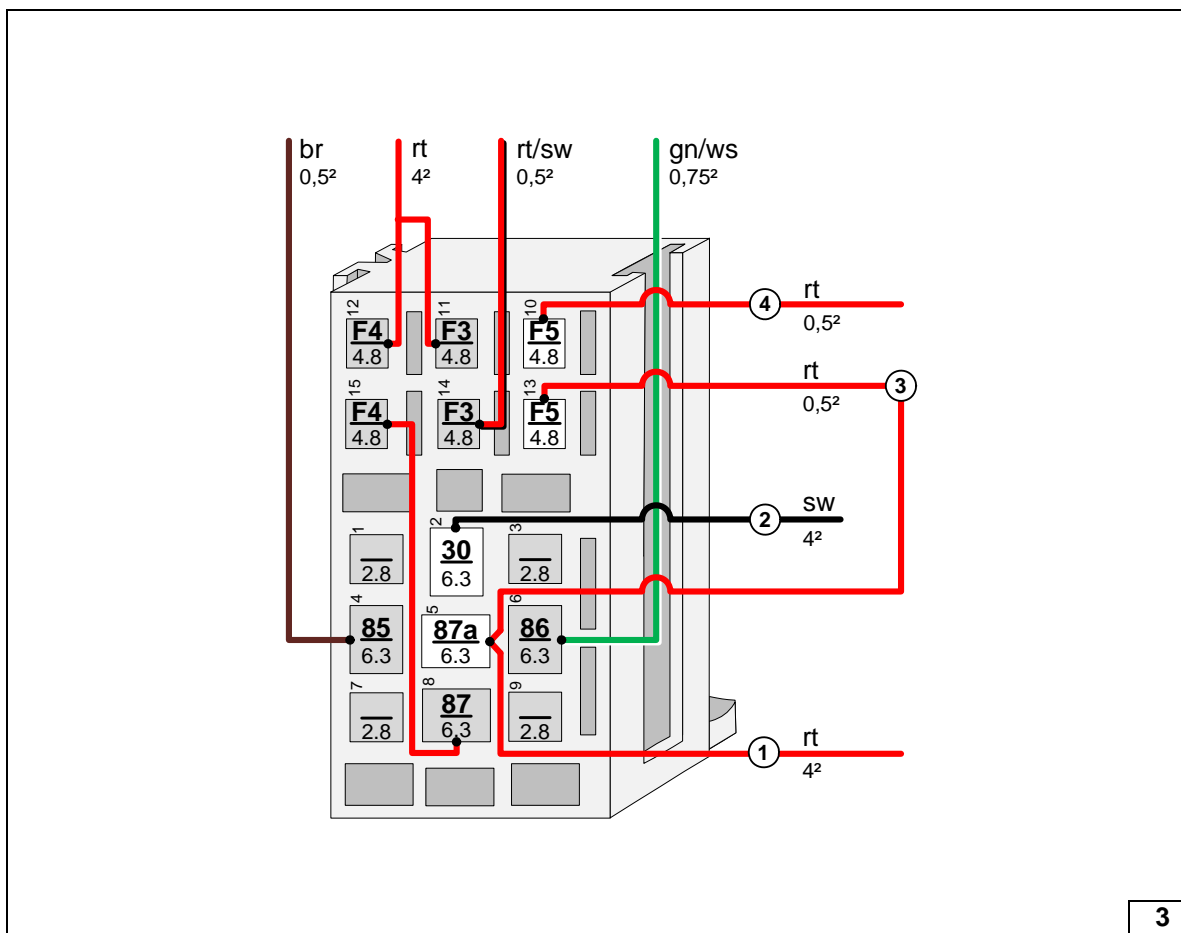

Connecting wires to passenger compartment relay and fuse holder

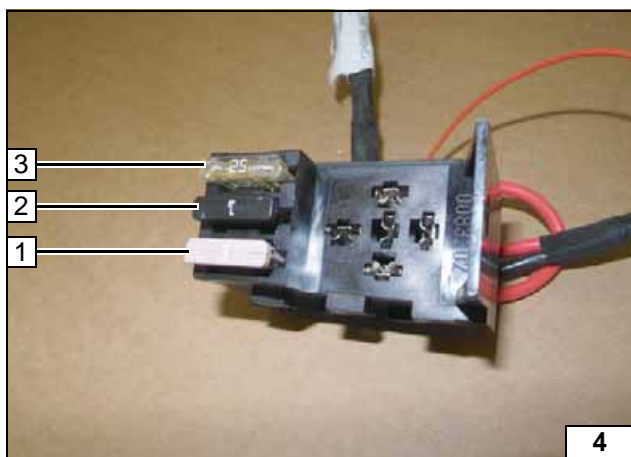

- 1 3A fuse F5
- 2 1A fuse F3
- 3 25A fuse F4

Inserting fuses

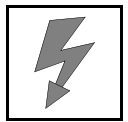

Connecting wires to socket of K2 relay

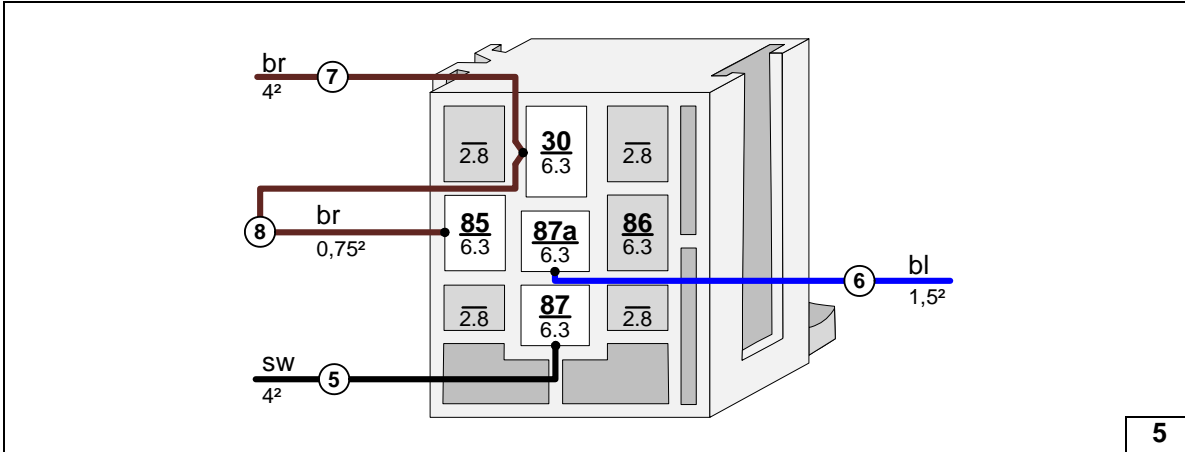

5



Assigning wires

Automatic air-conditioning

- ① Red (rt) wire of fan wiring harness
- ② Black (sw) wire of fan wiring harness
- ⑬ Pull green/white (gn/ws) wire into provided protective sleeving.

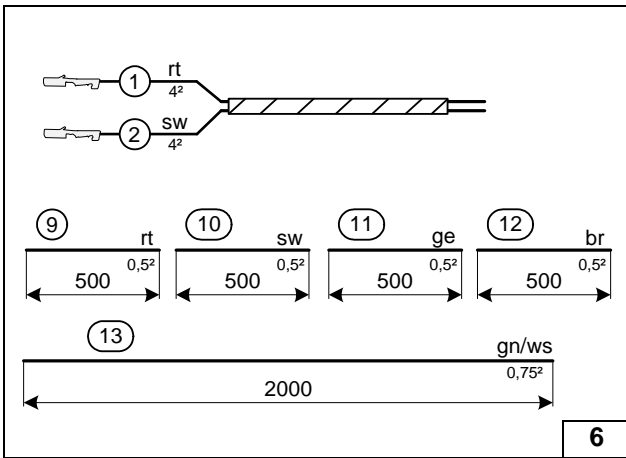

6



Preparing passenger compartment relay and fuse holder

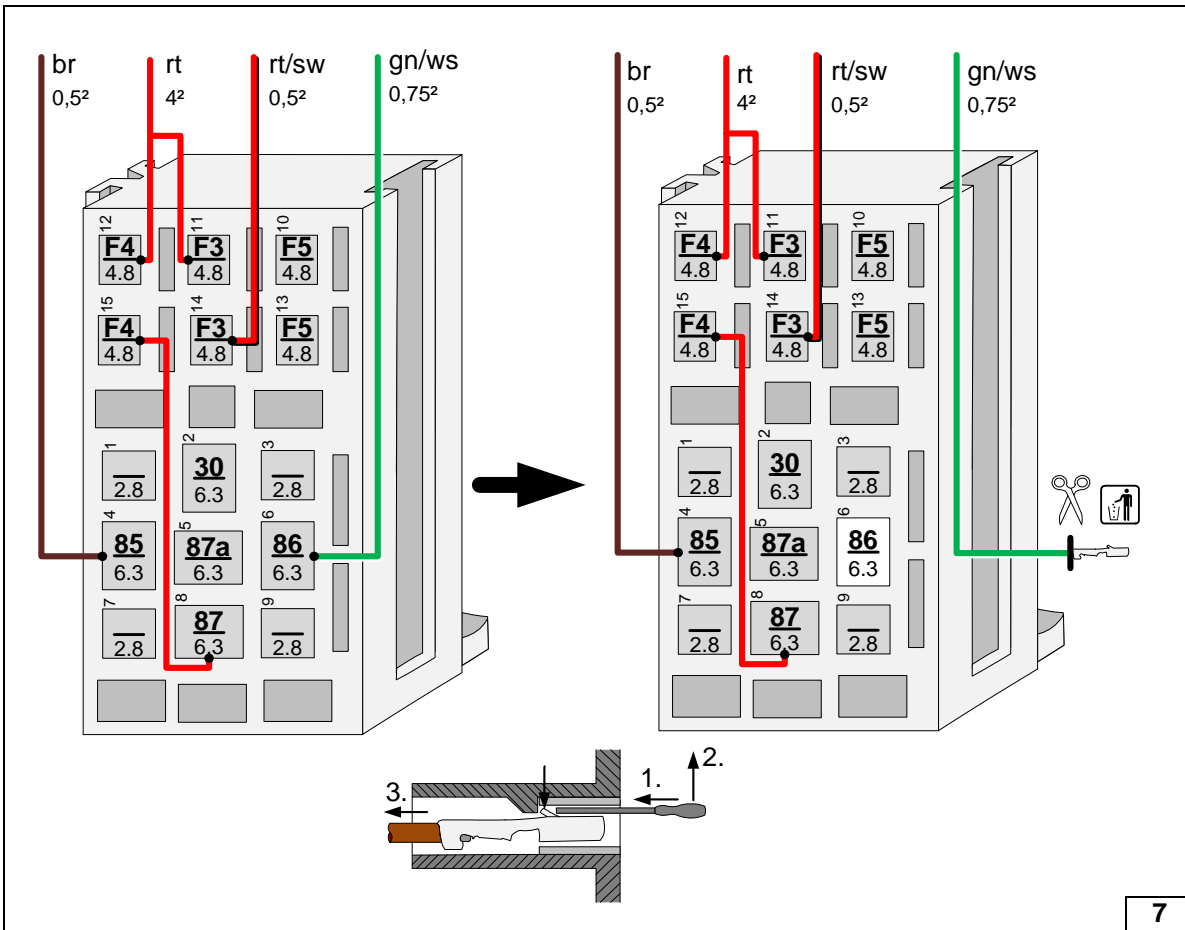

7

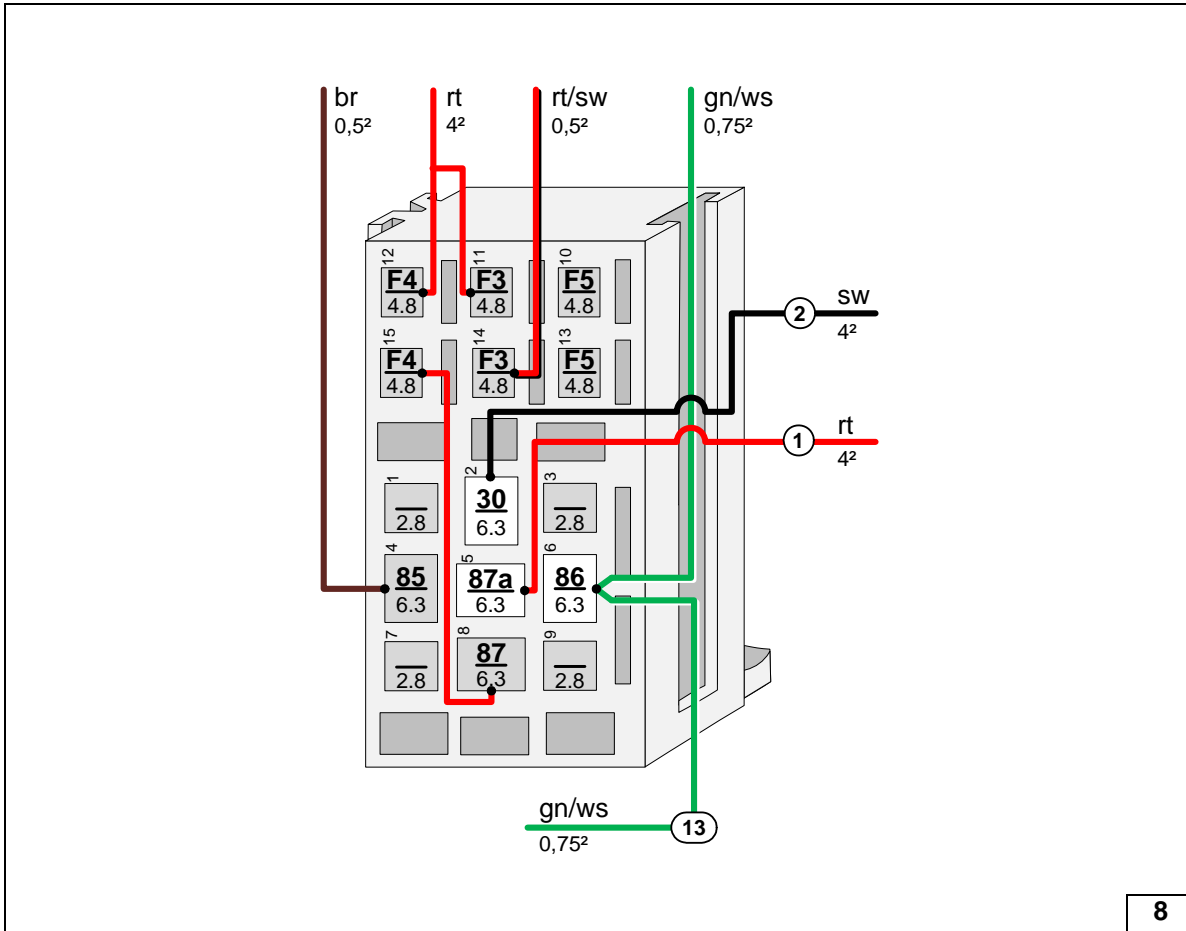
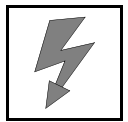

Connecting wires to passenger compartment relay and fuse holder

8

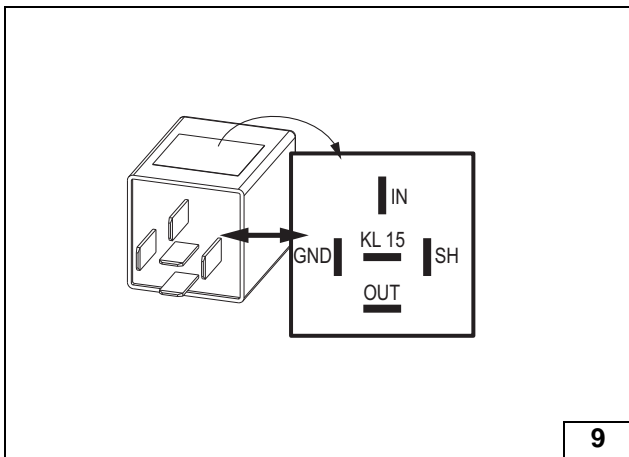

Before installation, program PWM Gateway with the following settings:

- Duty cycle: 33%
- Frequency: 1000Hz
- Voltage: 5V
- Function: High side



View of PWM GW

9

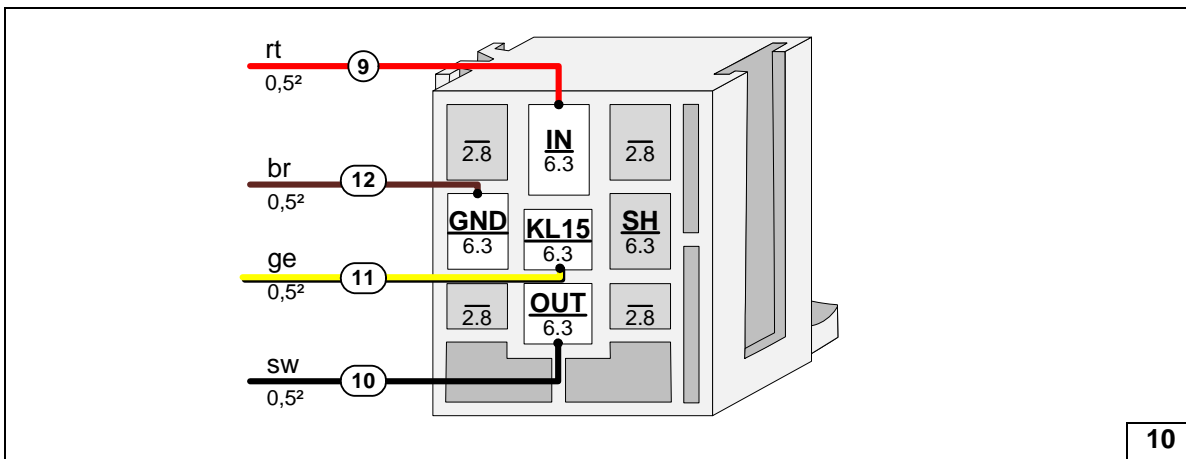

Connecting wires to PWM GW socket

10

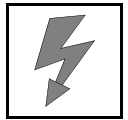

All vehicles

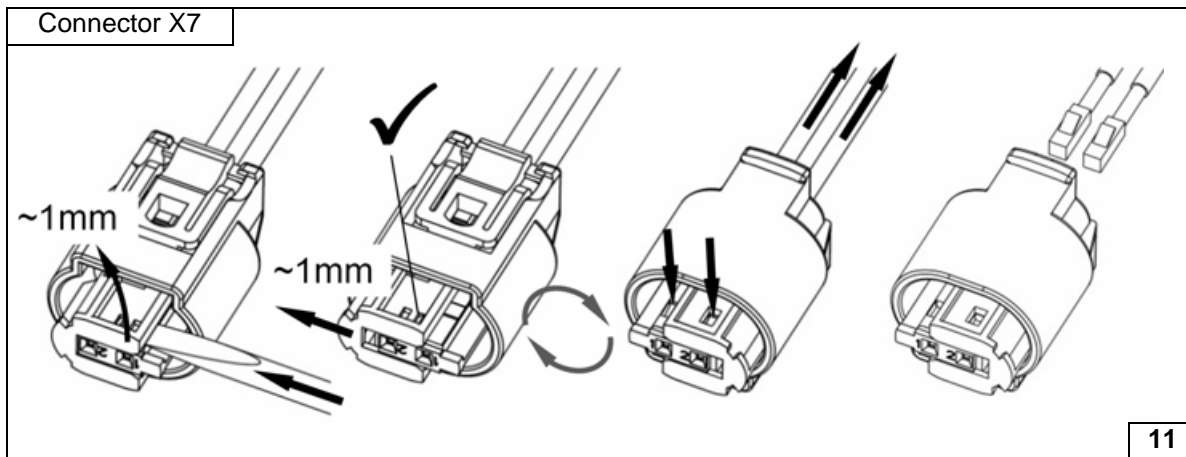

Dismantling metering pump connector



Electrical System

Earth wire

- 1 Earth wire on original vehicle earth support point

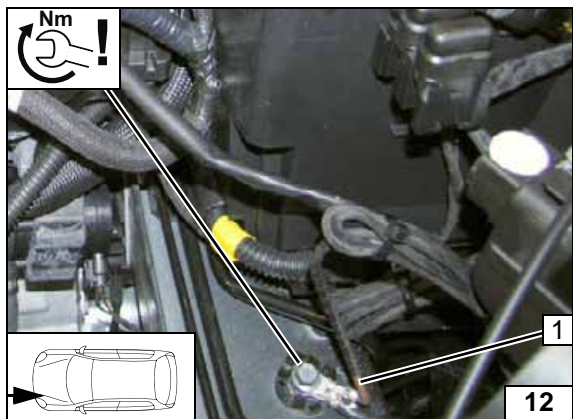

Positive wire

- 1 Positive wire on positive distributor

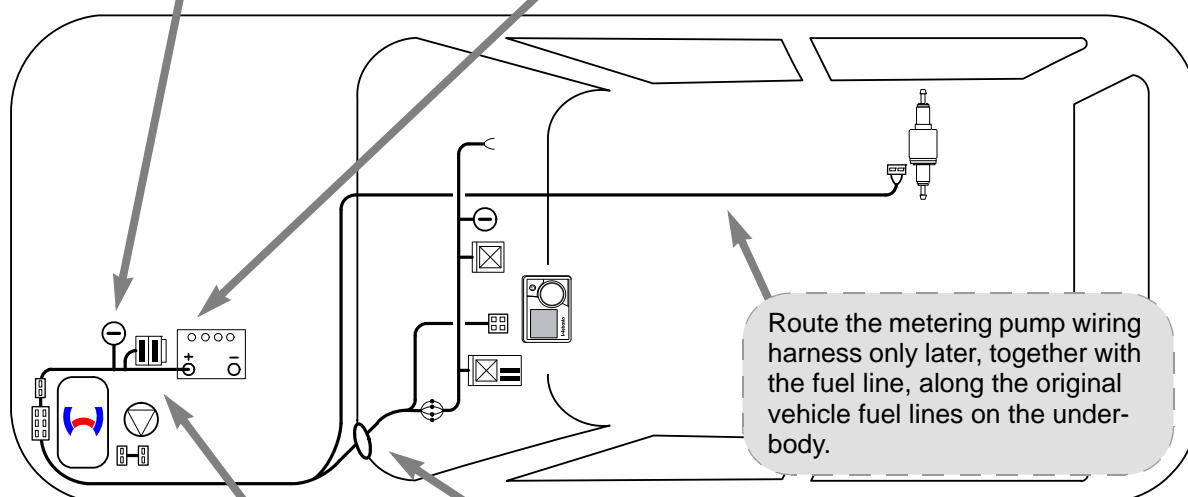
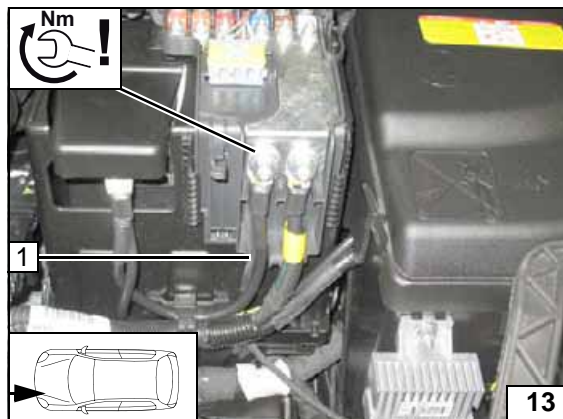

Wiring harness routing diagram

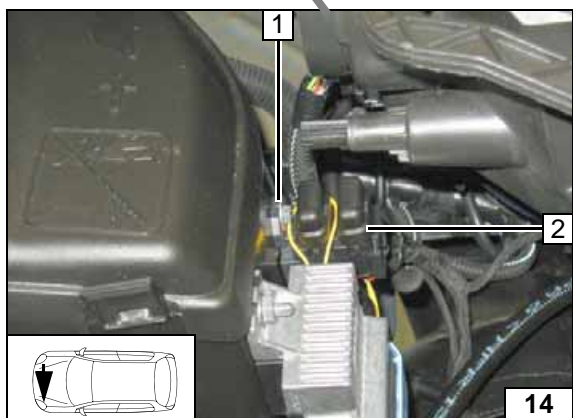

Engine compartment fuse holder

- 1 5.5 mm dia. hole; M5x16 bolt, washer [2x], retaining plate of fuse holder, nut
- 2 Fuses F1-2

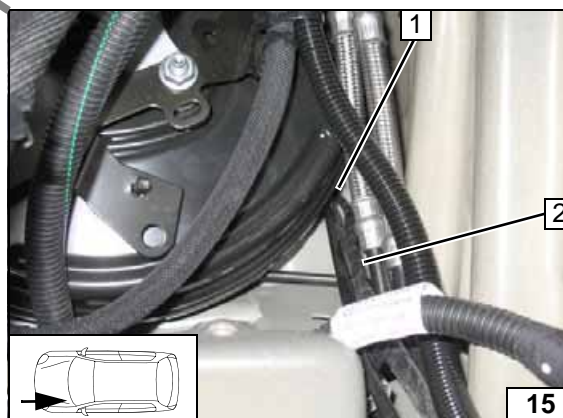

Wiring harness pass through

- 1 Cable grommet of bonnet Bowden cable
- 2 Wiring harnesses of heater, heater controls



Manual Air-Conditioning Fan Controller

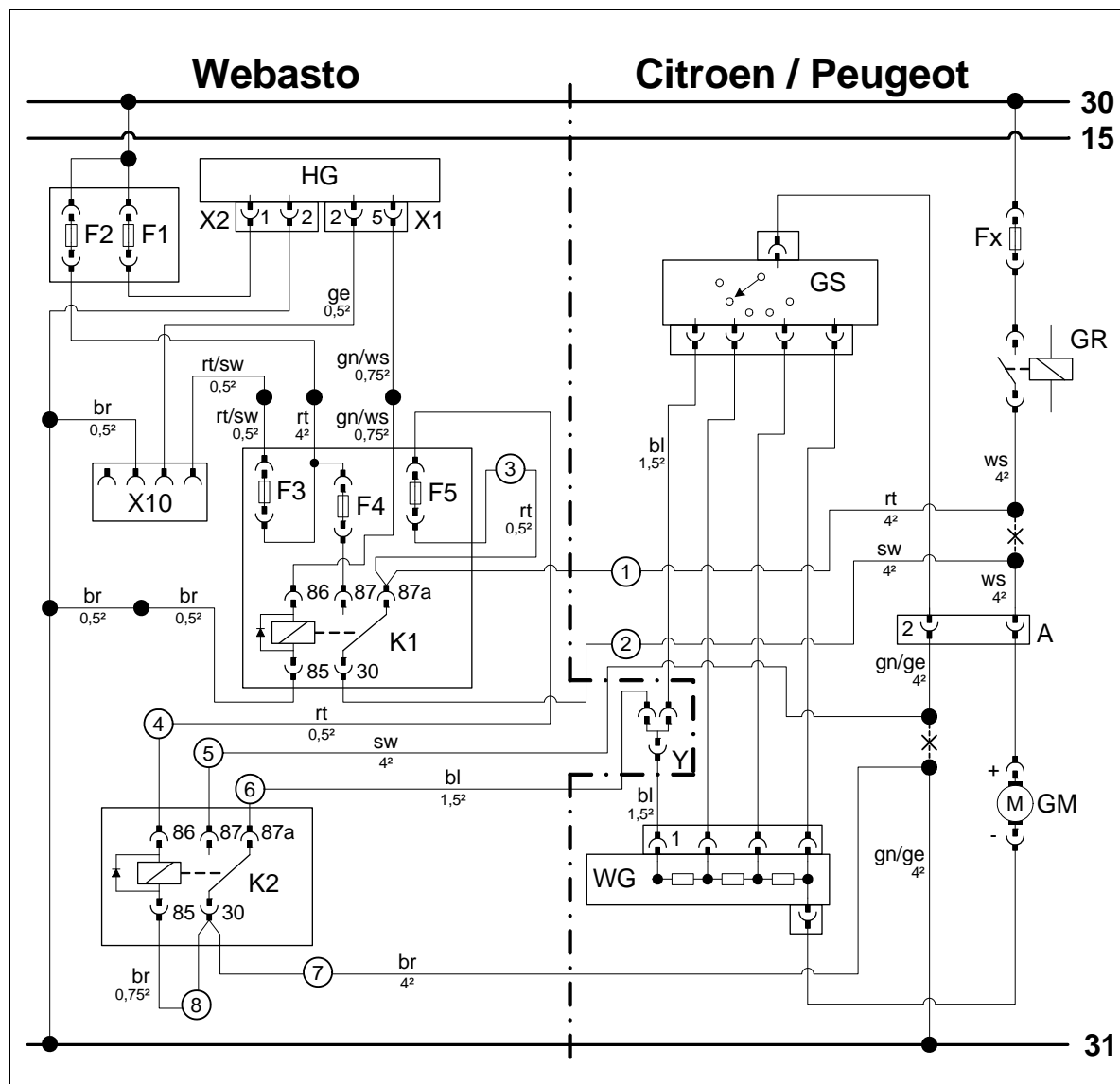

Wiring diagram

Webasto components		Vehicle components		Colours and symbols	
HG	TT-Evo heater	Fx	Fuse	rt	red
X1	6-pin heater connector	GS	Fan switch	sw	black
X2	2-pin heater connector	GR	Fan relay	ge	yellow
F1	20A fuse	A	6-pin connector	gn	green
F2	30A fuse	GM	Fan motor	bl	blue
X10	4-pin connector of heater control	WG	Resistor group	ws	white
F3	1A fuse			br	brown
F4	25A fuse				
F5	3A fuse				
K1	Fan relay				
Y	Y-adapter				
K2	Additional relay			X	Cutting point
				Wiring colours may vary.	

Legend

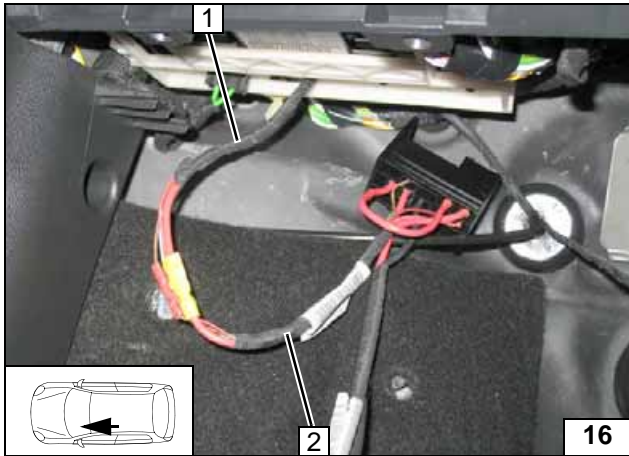

- 1 Heater wiring harness
- 2 Passenger compartment relay and fuse holder wiring harness

Connecting same colour wires of wiring harnesses

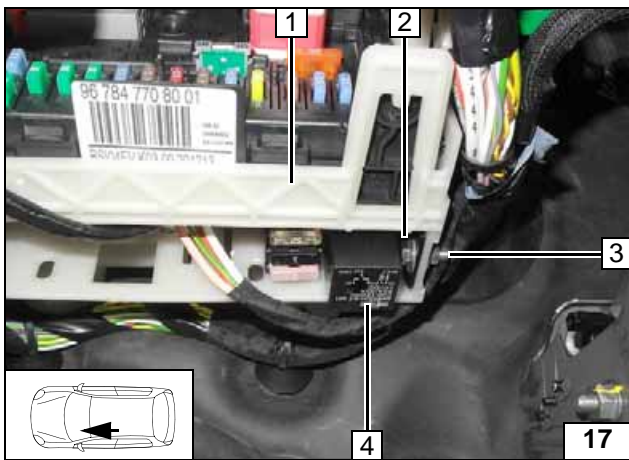

- 1 Fuse and relay box of passenger compartment
- 2 Passenger compartment relay and fuse holder
- 3 M5x16 bolt, large diameter washer [2x], nut, existing hole
- 4 K1 relay

Installing passenger compartment relay and fuse holder

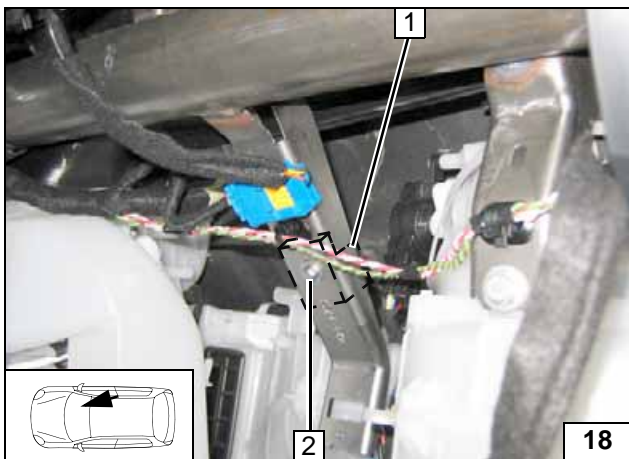

Insert red (rt) wire ④ of fuse F5 into K2/86 socket.



- 1 Socket of K2 relay covered (installed behind original vehicle strut)
- 2 M5x16 bolt, large diameter washer, flanged nut

Installing socket of K2 relay

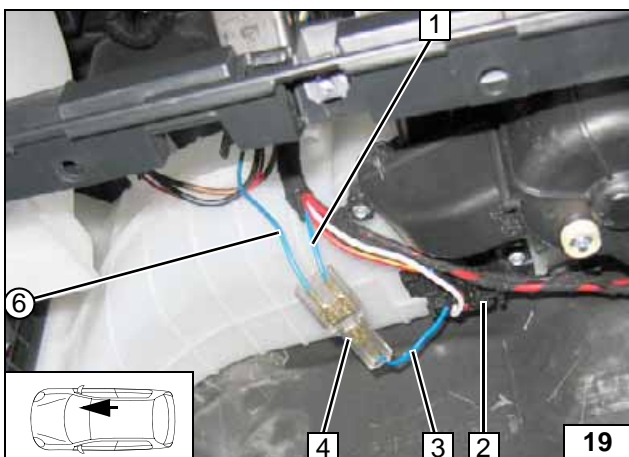

Connection to 5-pin connector 2 from resistor group.



- 1 Blue (bl) wire of fan switch
- 3 Blue (bl) wire of 5-pin connector, pin 1
- 4 Y-adapter
- ⑥ Blue (bl) wire of K2/87a

Connecting resistor group



1 6-pin connector A

Discon-
necting
connector
A

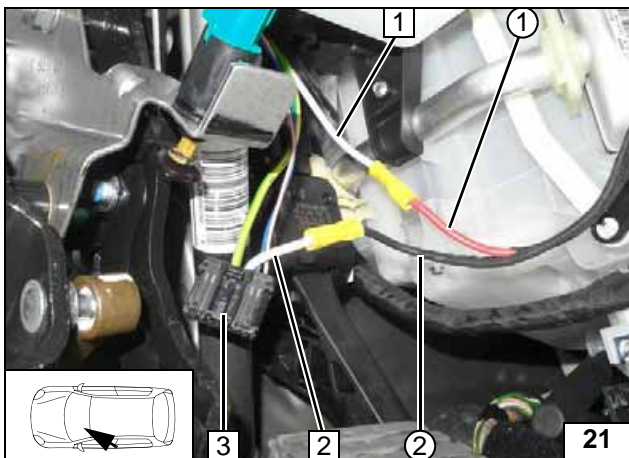

Connection on 6-pin connector A 3.

- 1 White (ws) wire of fan relay
- 2 White (ws) wire 6-pin connector A
- ① Red (rt) wire of K1/87a, fan wiring harness
- ② Black (sw) wire of K1/30, fan wiring harness



Connect-
ing fan mo-
tor

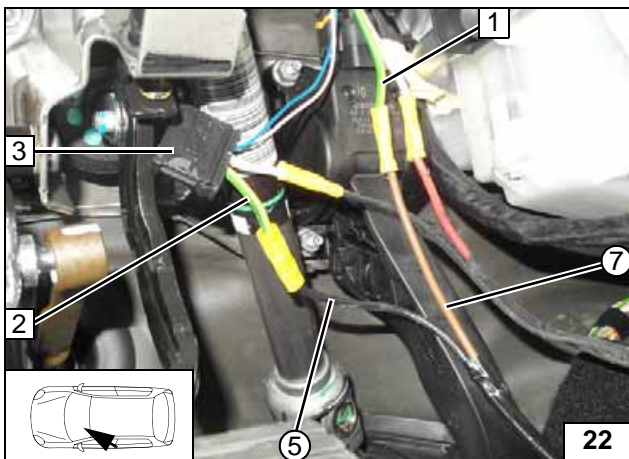

Connection on 6-pin connector A 3.

- 1 Green/yellow (gn/ge) wire of earth wire
- 2 Green/yellow (gn/ge) wire of 6-pin connector A
- ⑤ Black (sw) wire from K2/87
- ⑦ Brown (br) wire from K2/30



Connect-
ing fan
switch



Automatic Air-Conditioning Fan Controller

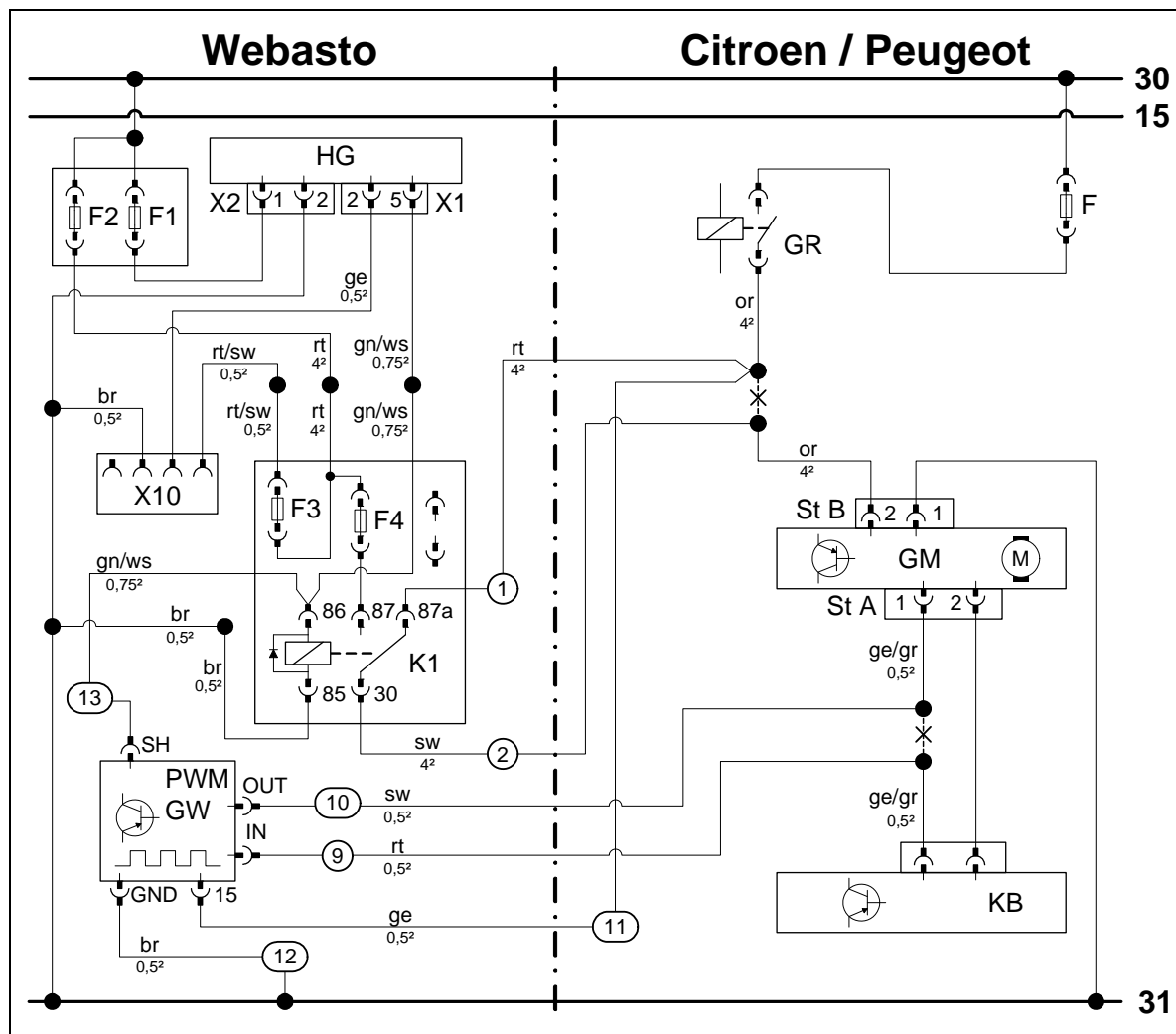

Wiring diagram

Webasto components		Vehicle components		Colours and symbols	
HG	TT-Evo heater	F	Fuse	rt	red
X1	6-pin heater connector	GR	Fan relay	sw	black
X2	2-pin heater connector	GM	Fan module	ge	yellow
F1	20A fuse	St B	2-pin connector of GM	gn	green
F2	30A fuse	St A	2-pin connector of GM	or	orange
X10	4-pin connector of heater control	KB	A/C control unit	ws	white
F3	1A fuse			br	brown
F4	25A fuse			gr	grey
K1	Fan relay				
PWM	Pulse width modulator				
GW	Gate driver				
PWM GW settings:					
Duty cycle: 33%					
Frequency: 1000Hz					
Voltage: 5V				X	Cutting point
Function: High side				Wiring colours may vary.	

Legend

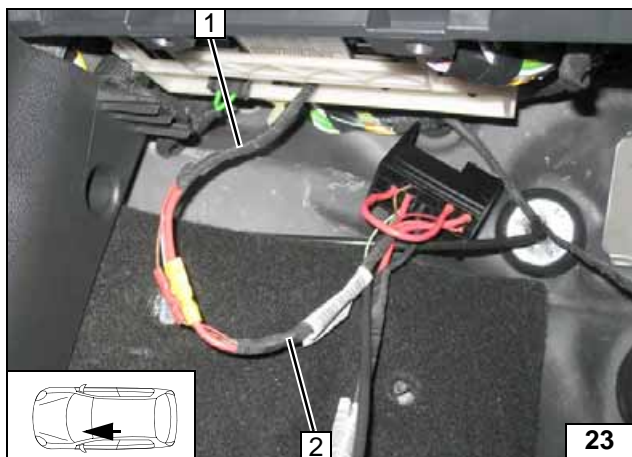

- 1 Heater wiring harness
- 2 Passenger compartment relay and fuse holder wiring harness

Connecting same colour wires of wiring harnesses

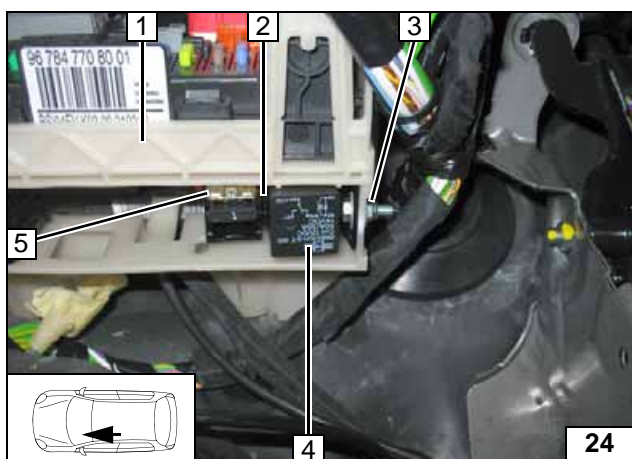

- 1 Fuse and relay box of passenger compartment
- 2 Passenger compartment relay and fuse holder
- 3 M5x16 bolt, large diameter washer [2x], nut
- 4 K1 relay
- 5 25A fuse F4

Installing passenger compartment relay and fuse holder

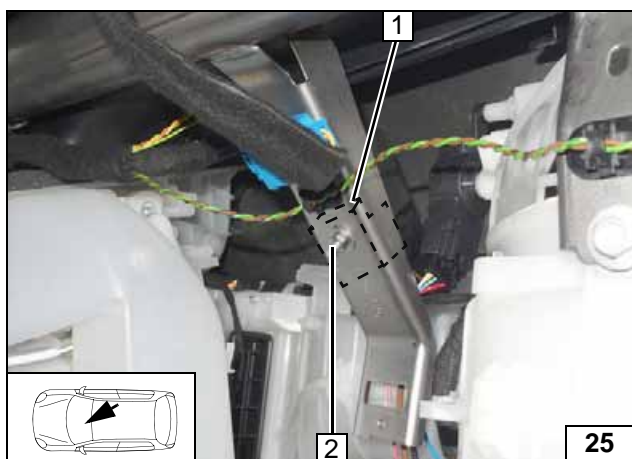

Before installation, connect green/white (gn/ws) wire from K1/86 to PWM GW/SH socket.

- 1 PWM GW socket, covered (installed behind original vehicle strut)
- 2 M5x16 bolt, large diameter washer, flanged nut

Installing PWM GW socket

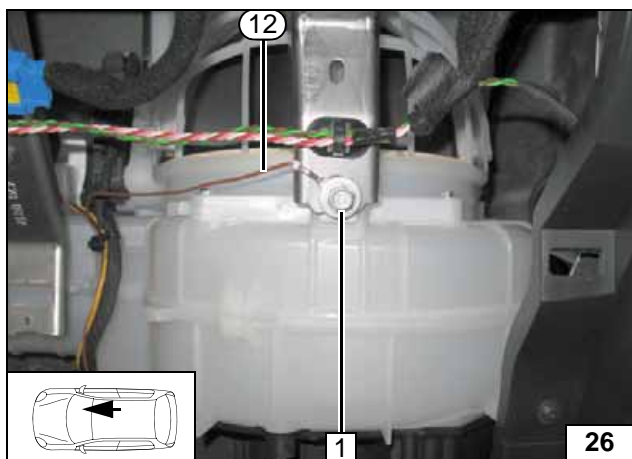

- 1 Original vehicle bolt
- ⑫ Brown (br) wire of PWM GW/GND, cable lug

PWM GW earth connection

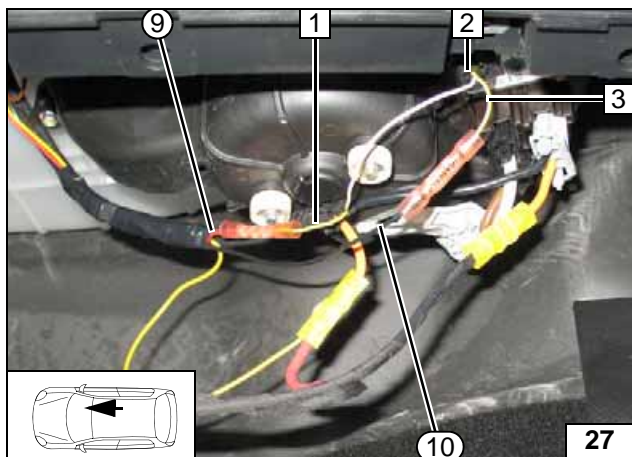

Fan controller is controlled on 2-pin connector A 2 of fan module.



- 1 Yellow/grey (ge/gr) wire of A/C control panel
- 3 Yellow/grey (ge/gr) wire of connector A, Pin 1
- ⑨ Red (rt) wire of PWM GW/IN
- ⑩ Black (sw) wire of PWM GW/OUT

**Connec-
tion to fan
module**

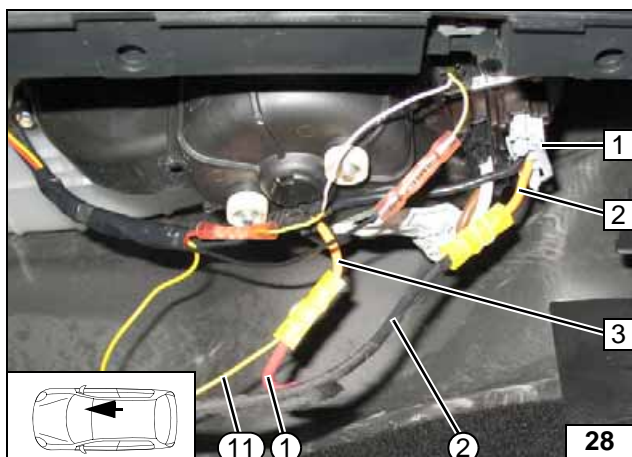

Fan motor is controlled on 2-pin connector B 1 of fan module.



- 2 Orange (or) wire of connector B, pin 2
- 3 Orange (or) wire of GR
- ① Red (rt) wire of K1/87a
- ② Black (sw) wire of K1/30
- ⑪ Yellow (ge) wire of PWM GW/K115

**Connec-
tion to fan
module**

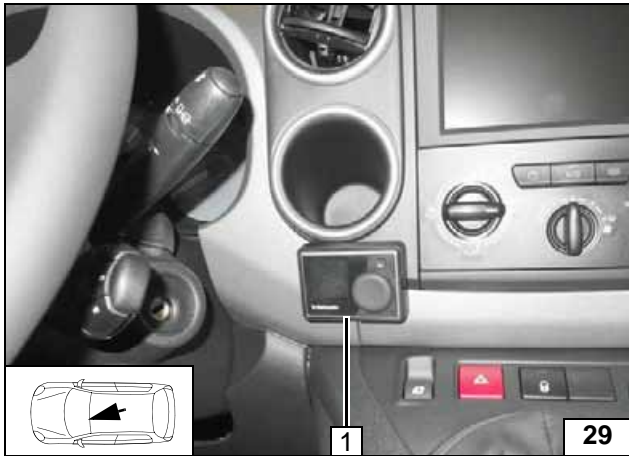

MultiControl CAR Option

- 1 Installation frame



Installing
MultiControl
CAR



Remote Option (Telestart)

Fasten receiver 1 with double-sided adhesive tape.



Installing
receiver

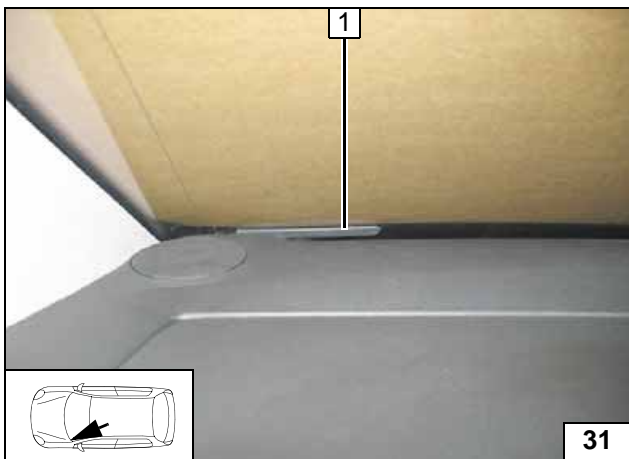

- 1 Aerial

Installing
aerial

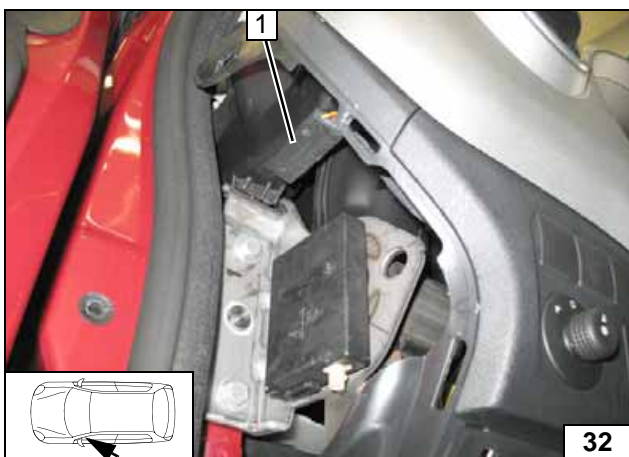

Temperature sensor T100 HTM

Fasten temperature sensor 1 with double-sided adhesive tape.



Installing
temperature
sensor



ThermoCall Option

Fasten receiver 1 with double-sided adhesive tape.

Installing receiver

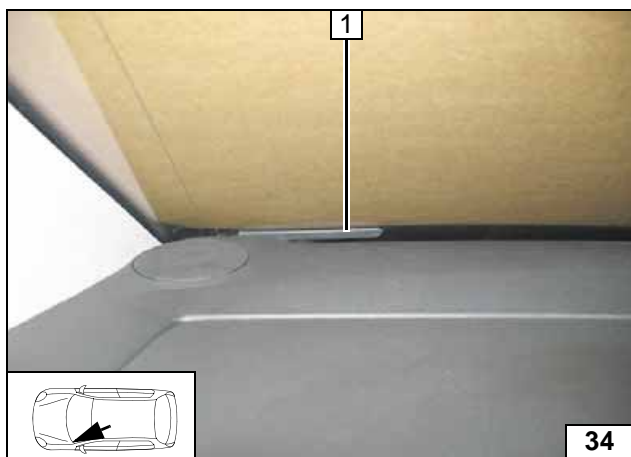

1 Aerial (optional)

Installing aerial

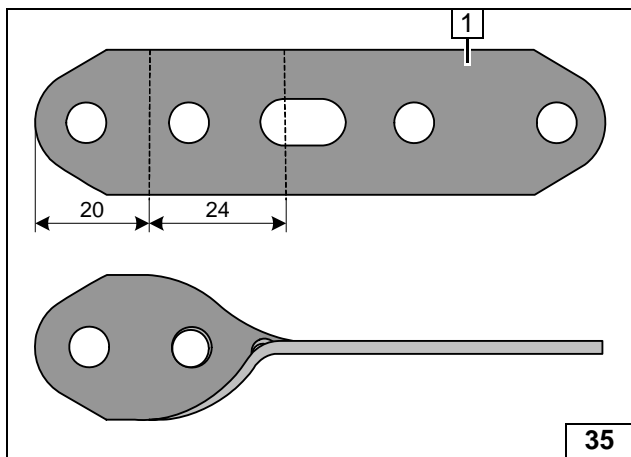

Preparing Installation Location

- 1 Twist perforated bracket in longitudinal axis

Preparing perforated bracket

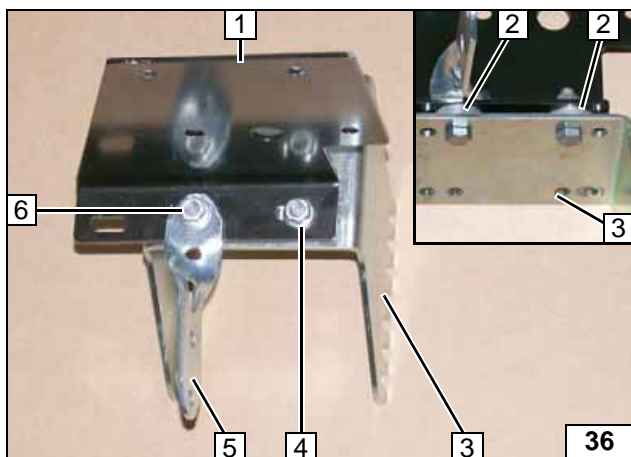

Install retaining plate 1 and bracket 3.

- 2 5 mm shim
- 4 M6x16 bolt, 5 mm shim, flanged nut
- 5 Perforated bracket
- 6 M6x20 bolt, 5 mm shim, flanged nut



Premounting bracket

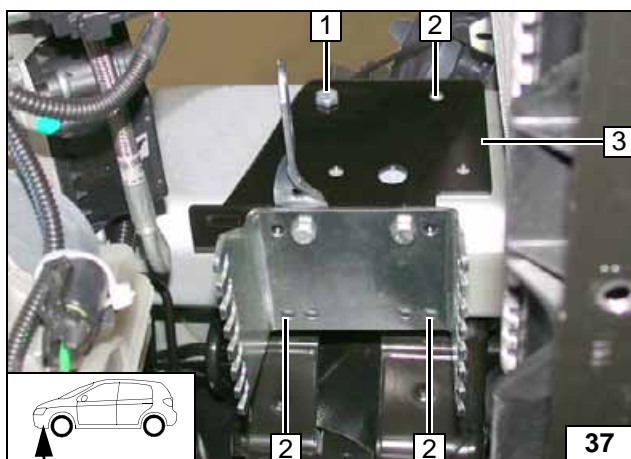

68 kW

Install retaining plate with bracket 3 loosely .

- 1 M6x20 bolt, existing threaded hole
- 2 Copy hole pattern [3x]



Copying hole pattern

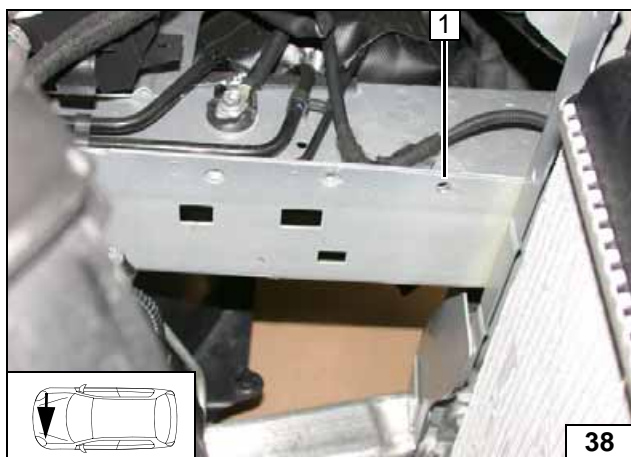

Remove retaining plate with bracket.

- 1 7 mm dia. hole



Hole in frame side member

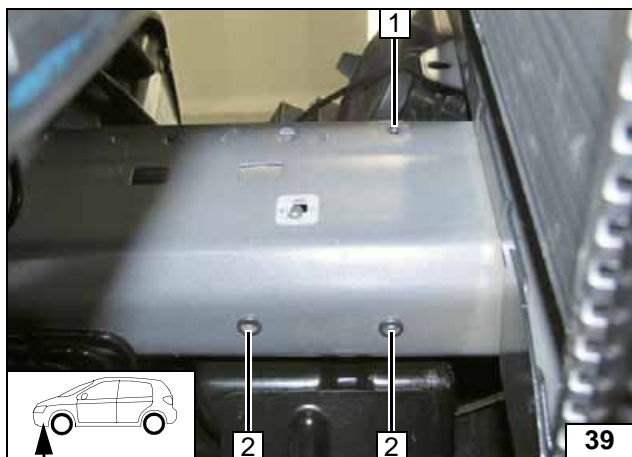

- 1 7 mm dia. hole
- 2 9.1mm dia. hole; rivet nut [2x each]

Hole in frame side member, installing rivet nut

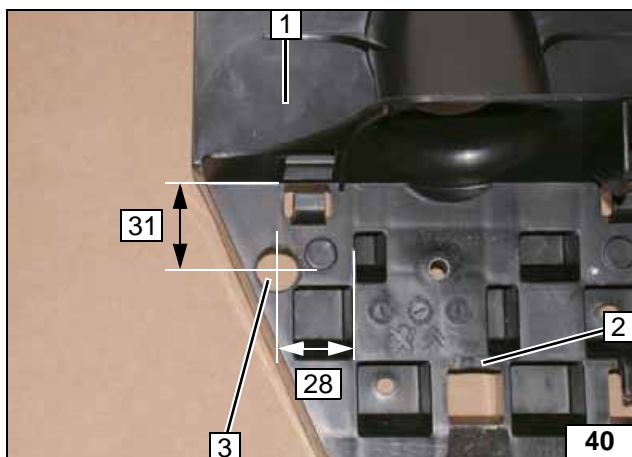

Cut out tab at position 2.

- 1 Bracket of air-intake pipe
- 3 12 mm dia. hole

Preparing bracket of air intake pipe

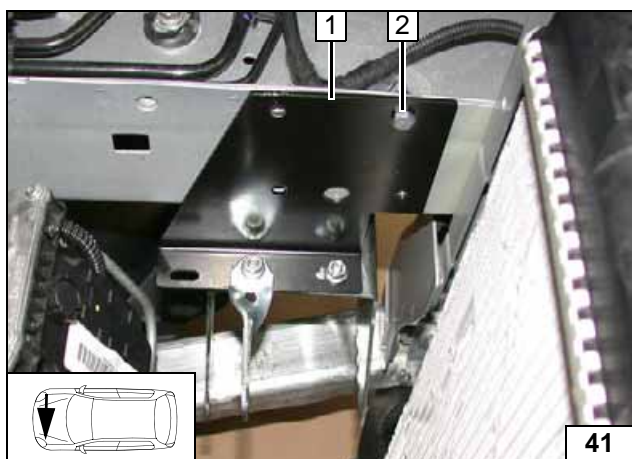

- 1 Retaining plate with bracket
- 2 M6x20 bolt, flanged nut

Installing bracket

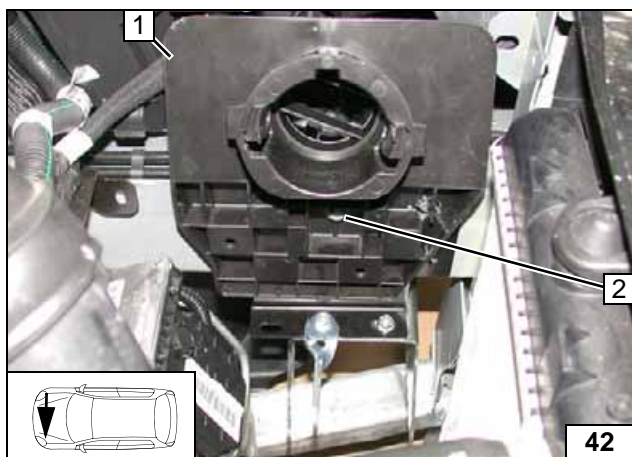

- 1 Bracket of air-intake pipe
- 2 Original vehicle bolt

Installing bracket of air-intake pipe

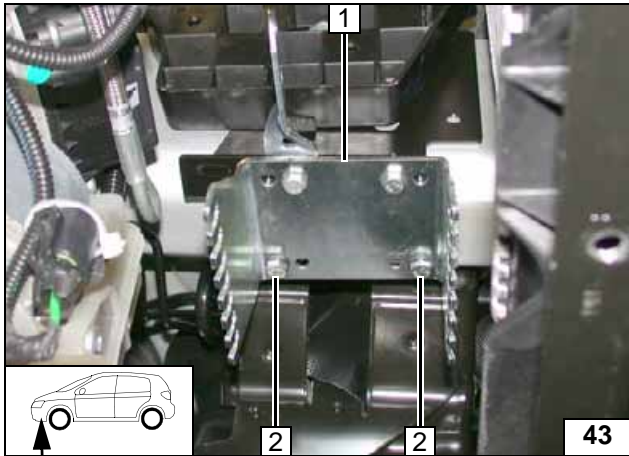

- 1 Bracket
- 2 M6x35 bolts [2x], spring lockwasher [2x], bracket, 20 mm shim [2x]

Installing bracket

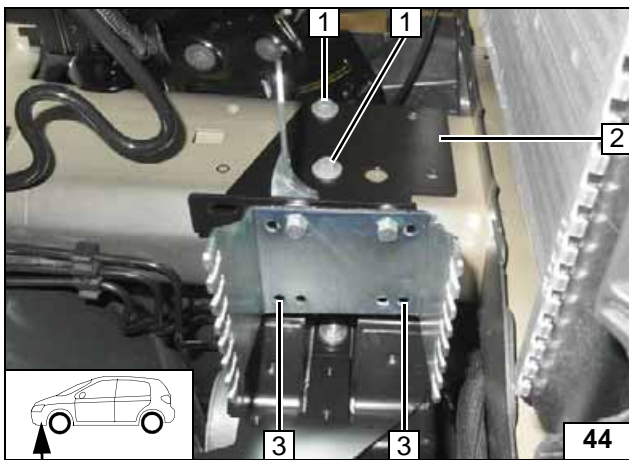

73 / 88 kW

Remove original vehicle relay.
Install retaining plate with bracket 2 loosely .

- 1 Original vehicle bolt in existing hole [2x]
- 3 Copy hole pattern [2x]

Copying hole pattern

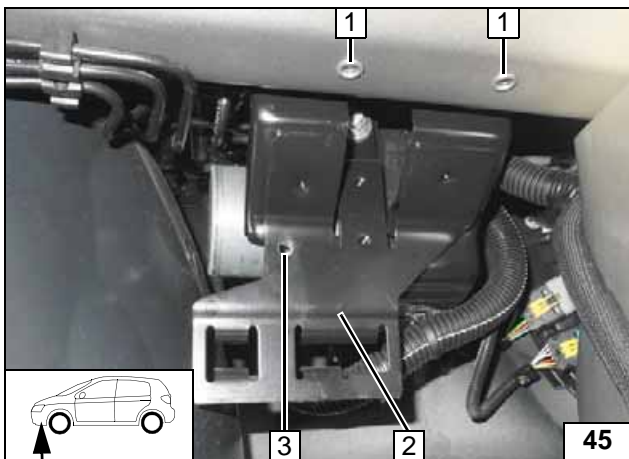

Remove retaining plate with bracket.

- 1 9.1mm dia. hole; rivet nut [2x each]
- 2 ABS carrier
- 3 Drill out existing hole to 7mm dia.

Hole in frame side member / ABS carrier, inserting rivet nut



Secure original vehicle wiring harness with cable tie at position 1.

- 2 Install M6x20 bolt, large diameter washer, flanged nut loosely

Installing original vehicle relay

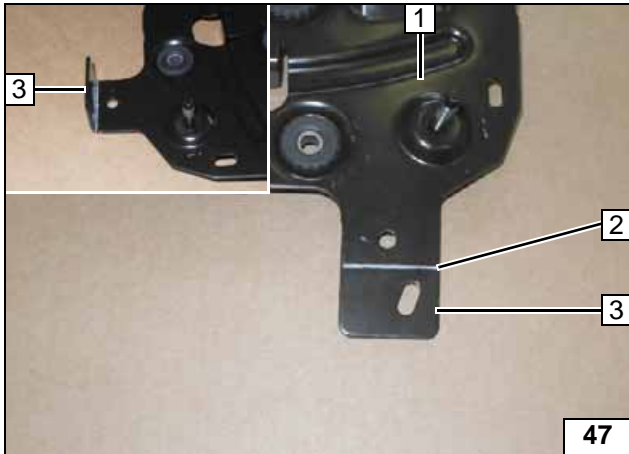
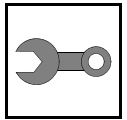

Bend tab 3 of original vehicle bracket 1 by 90° upwards at bending line 2 .



Preparing original vehicle bracket

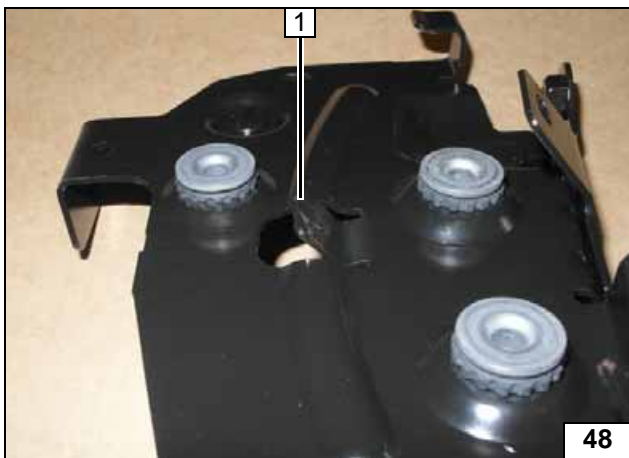

Bend tab 1 as shown.



Preparing original vehicle bracket

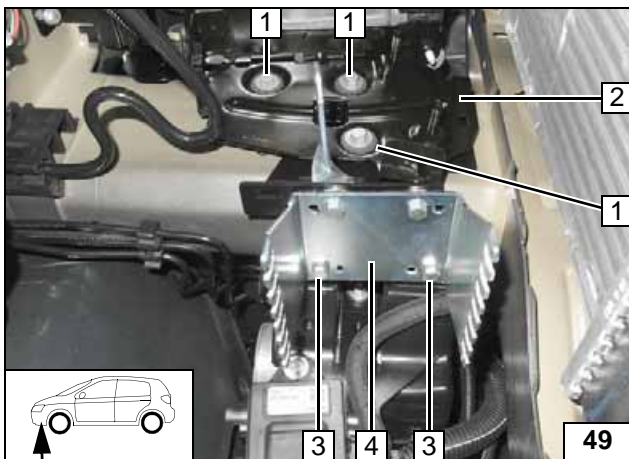

- 1 Original vehicle bolts [3x]
- 2 Original vehicle bracket
- 3 M6x35 bolt, spring lockwasher, 20mm shim [2x each]
- 4 Bracket

Installing bracket

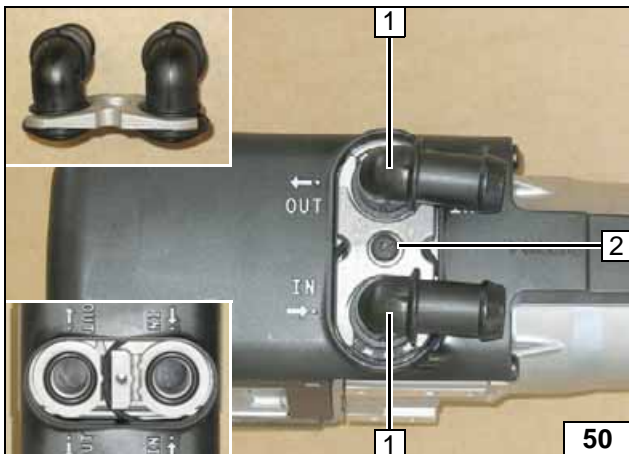

Preparing Heater

All vehicles

- 1 Water connection piece, sealing ring [2x each]
- 2 5x15 self-tapping bolt, retaining plate of water connection piece



Installing water connection piece

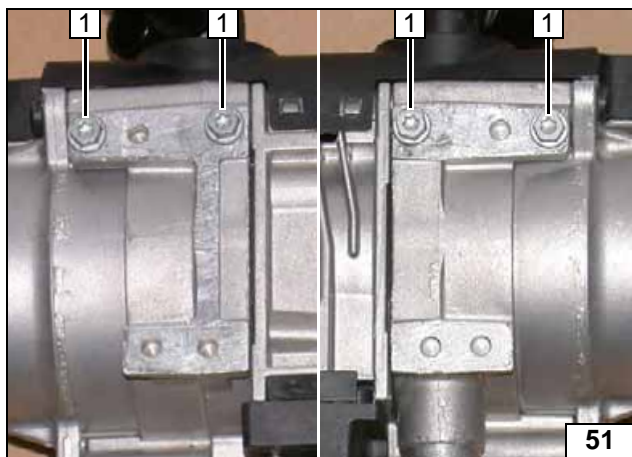

Screw 5x13 self-tapping bolts **1** [4x] into existing holes by a maximum of 3 thread turns.



Premounting bolts loosely

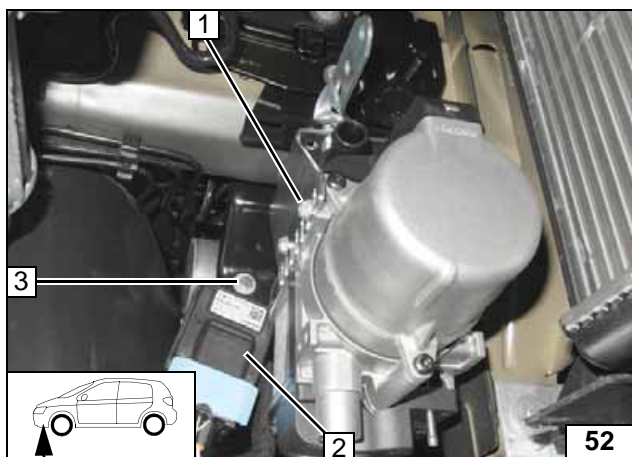

Heater as shown in position **2**. Insert slit of bracket **1**. Align original vehicle relay **2**, tighten flanged nut **3**. Ensure sufficient distance between heater and wheel well trim; correct if necessary.



Aligning original vehicle relay

Remove heater again.

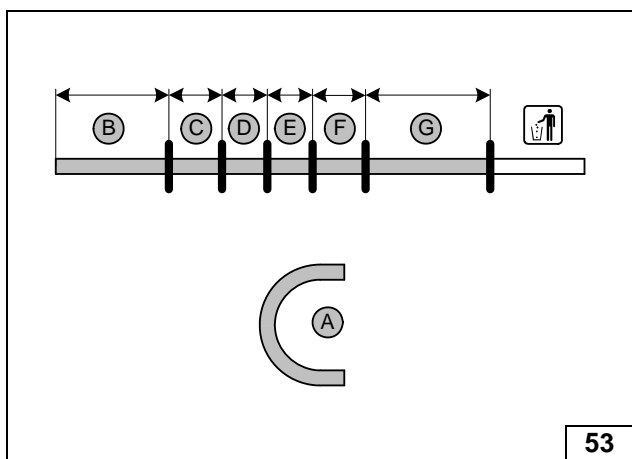

- A** = 180°, 18mm dia.
- B** = 440
- C** = 60
- D** = 60
- E** = 60
- F** = 100
- G** = 550



Cutting hoses to length

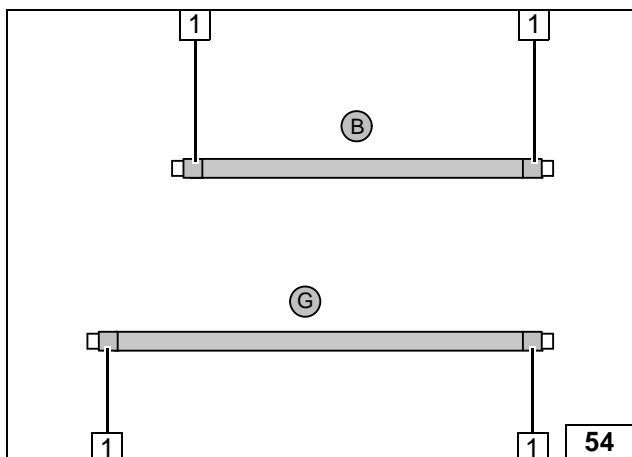

Push braided protection hoses onto hose **B** and **G** and cut to length. Cut heat shrink plastic tubing to size.



- 1** 50 mm long heat shrink plastic tubing [4x]

Preparing hoses

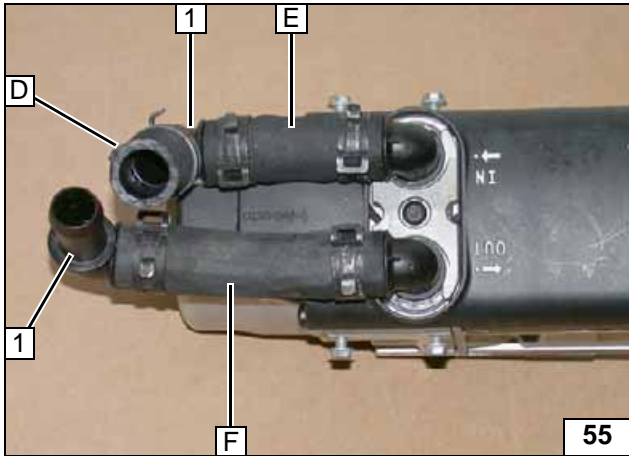

All spring clips = 25mm dia.!

- 1 90°, 18x18 connecting pipe

Premounting hoses

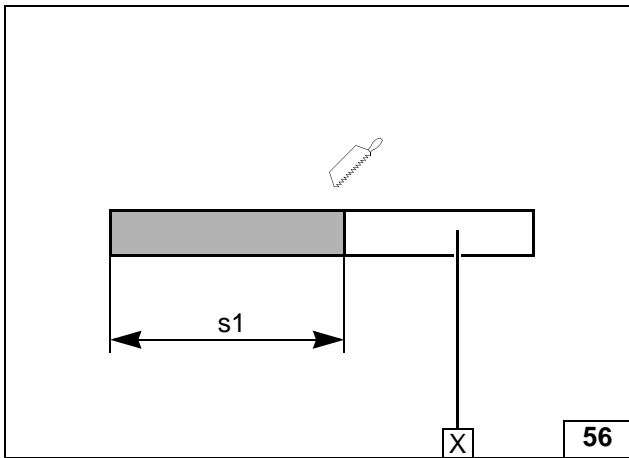

s1 = 260

X =

Cutting combustion air pipe s1 to length

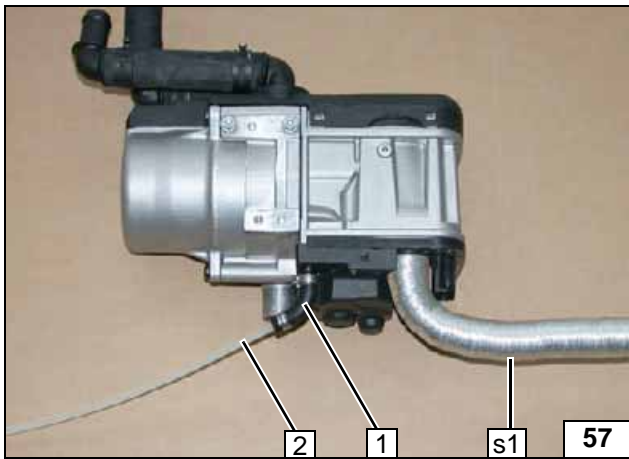

- 1 90° moulded hose, 10mm dia. clamp [2x]
- 2 Fuel line



Premounting heater

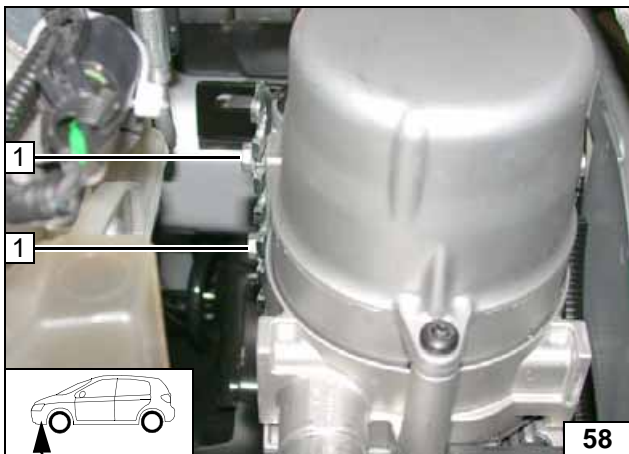

Images show vehicle with EGS 6.

- 1 Tighten 5x13 self-tapping bolt [2x]



Installing heater

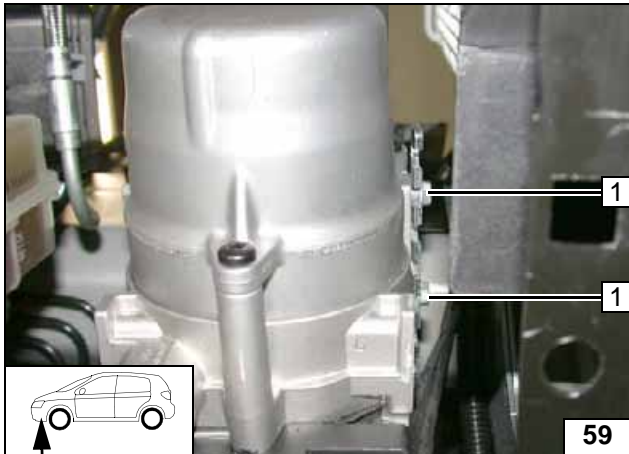

1 Tighten 5x13 self-tapping bolt [2x]

Installing
heater

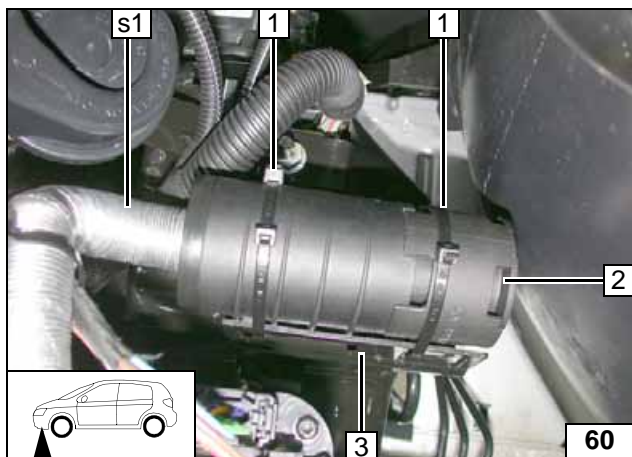
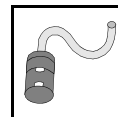

Combustion Air

- 1 Cable tie [2x]
- 2 Silencer
- 3 ABS bracket



Installing
silencer



Fuel

CAUTION!

Open the vehicle's fuel tank cap, ventilate the tank and then re-close the tank lock.

Catch any fuel running off in an appropriate container.

Route fuel line and metering pump wiring harness so that they are protected against stone impact. Unless specified otherwise, always fasten using cable ties.

Provide rub protection for fuel line and wiring harness in areas where there are sharp edges.

WARNING!

The fuel line and wiring harness are routed to the metering pump as shown in the wiring harness routing diagram.

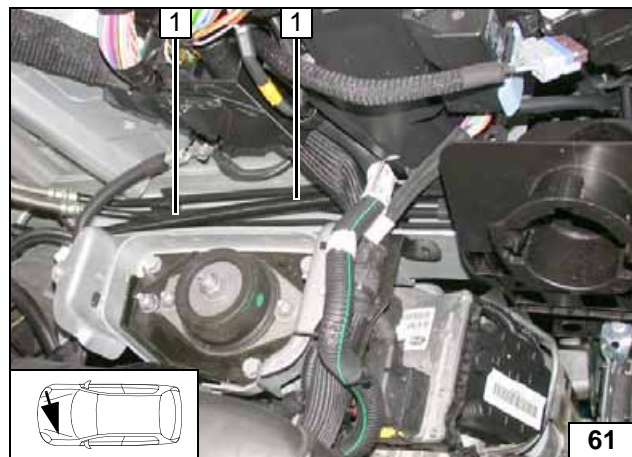

Route fuel line and wiring harness of metering pump into 2100mm corrugated tube 1 to the firewall.

Routing lines

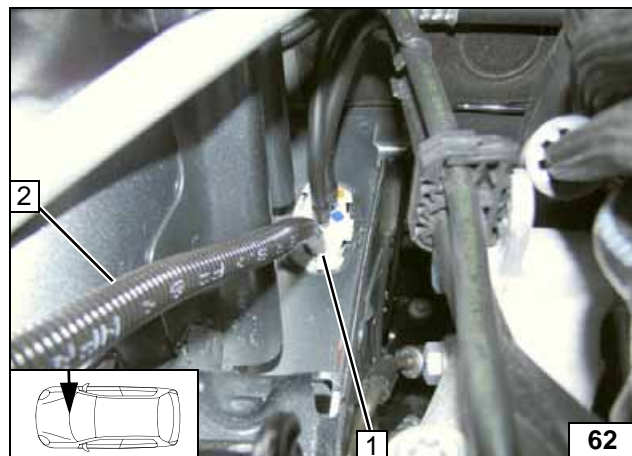

Route fuel line and wiring harness of metering pump in original vehicle line duct to the underbody.

- 1 Original vehicle pass through
- 2 Fuel line and wiring harness of metering pump in corrugated tube

Routing lines

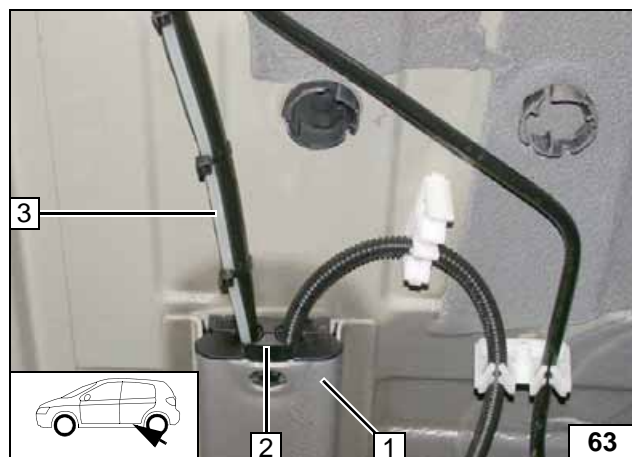

- 1 Original vehicle line duct
- 2 Original vehicle sealing
- 3 Fuel line, wiring harness of metering pump

Routing lines

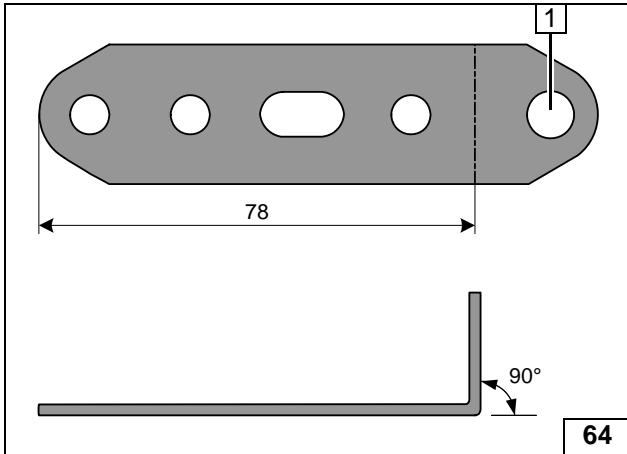
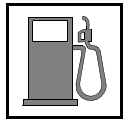

68 kW

- 1 Drill out hole to 9 mm dia.

Preparing perforated bracket

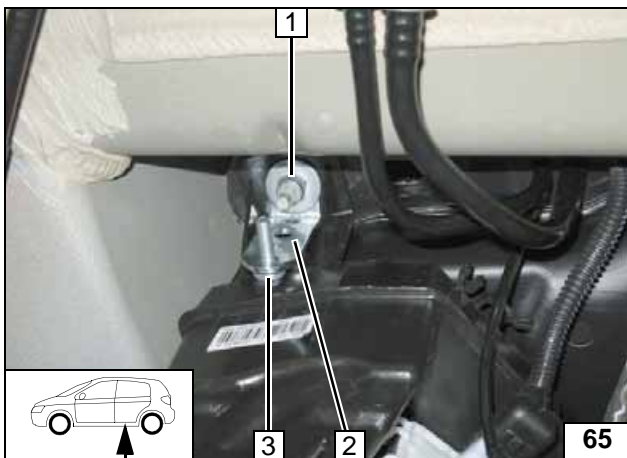

- 1 Original vehicle bolt
- 2 Perforated bracket
- 3 Mount M6x25 bolt

Installing perforated bracket

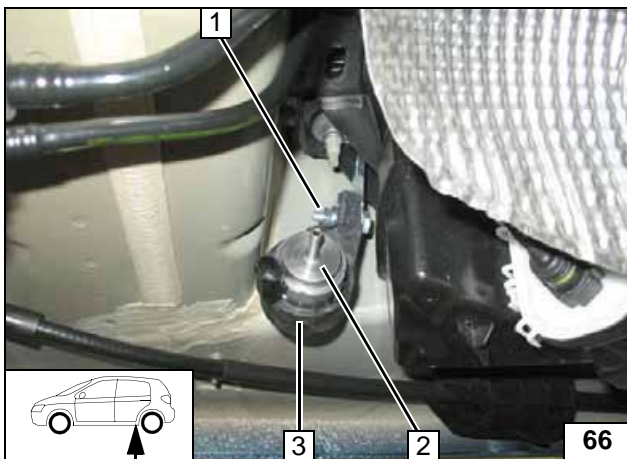

- 1 Flanged nut, support angle bracket
- 2 Metering pump
- 3 Metering pump mount



Installing metering pump

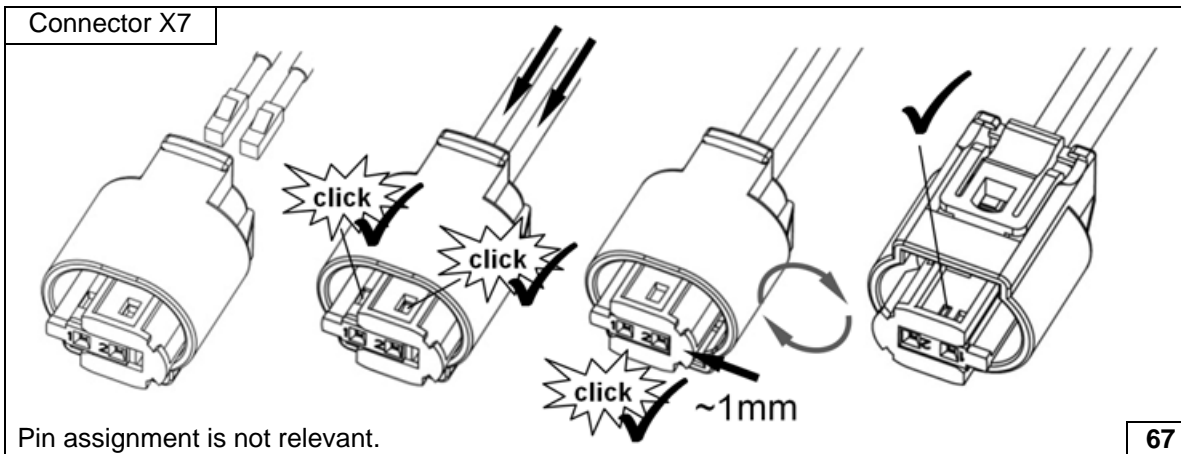

Completing metering pump connector

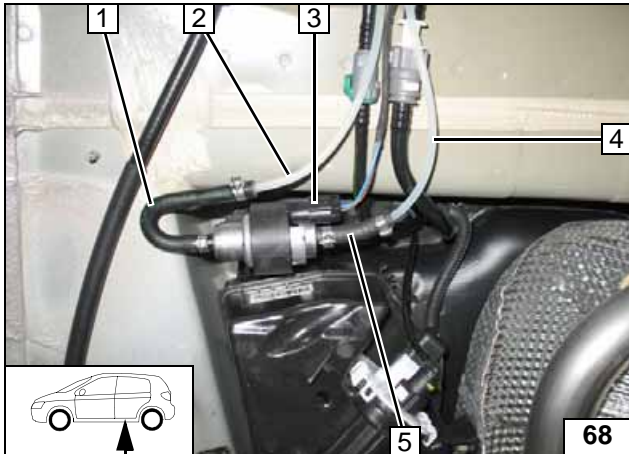
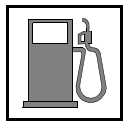

Check the position of the components; adjust if necessary. Check that they have freedom of movement.



- 1 180° moulded hose, 10mm dia. clamp [2x]
- 2 Fuel line of fuel standpipe
- 3 Metering pump wiring harness, connector X7 mounted
- 4 Fuel line of heater
- 5 Hose section, 10mm dia. clamp [2x]

**Connect-
ing meter-
ing pump**

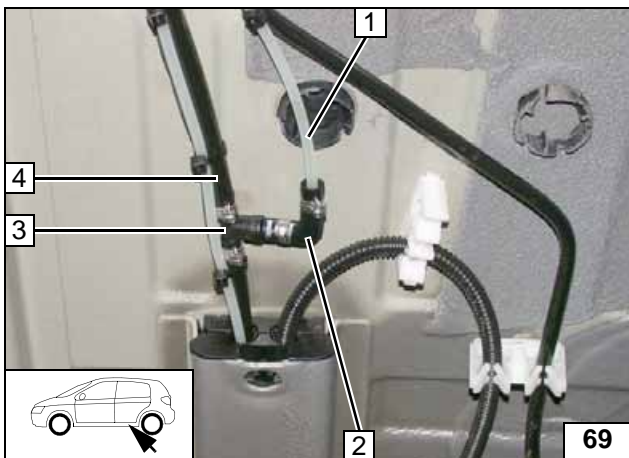

Check the position of the components; adjust if necessary. Check that they have freedom of movement.
Cut off fuel supply line 4 at position 3.



- 1 Fuel line
- 2 90° moulded hose, 10mm dia. clamp [2x]
- 3 8x5x8 fuel standpipe, 10mm dia. clamp [2x]

**Fuel extrac-
tion**

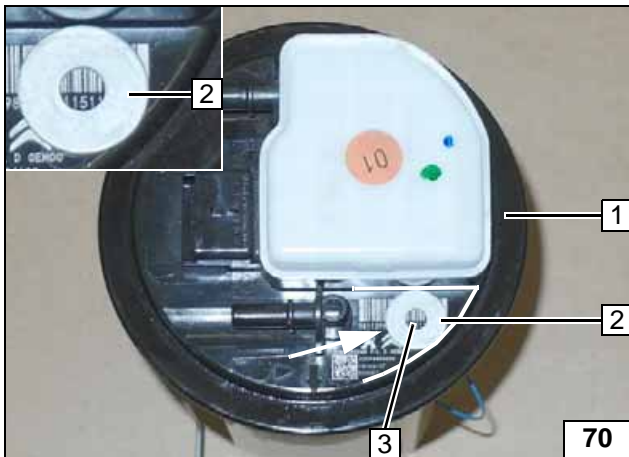

73 / 88 kW

Disconnect and remove fuel tank sending unit 1 according to the manufacturer's instructions.



- 2 Position washer with outer dia. $d_a = 21.6\text{mm}$ as shown, will be used as a template
- 3 Copy hole pattern

**Fuel extrac-
tion**

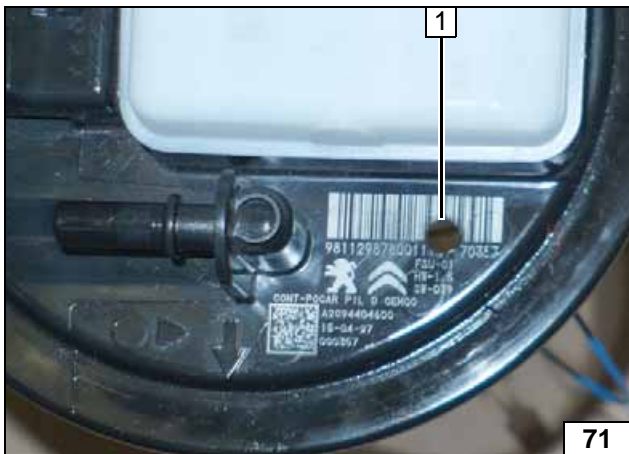

- 1 6 mm dia. hole



**Hole in fuel
tank sending
unit**

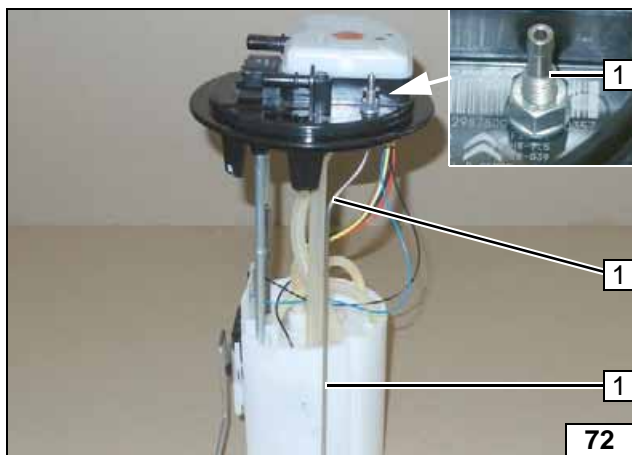

Bend fuel standpipe 1 according to template and cut to length.

Installing fuel standpipe

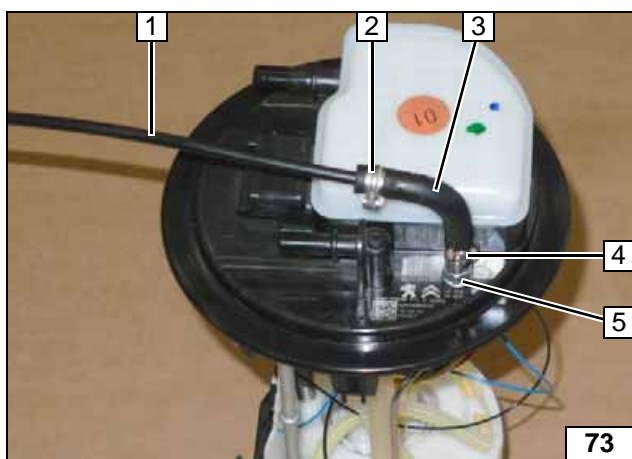

- 1 1500mm long fuel line of fuel standpipe
- 2 10 mm dia. clamp
- 3 3.5x4.5mm dia. moulded hose
- 4 9 mm dia. clamp
- 5 Fuel standpipe

Connecting fuel line

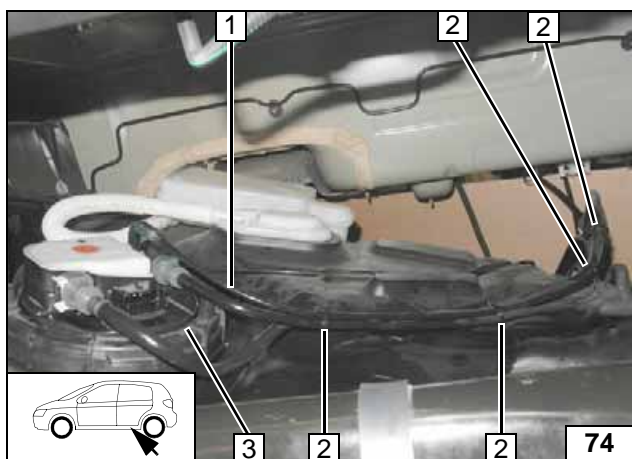

Install fuel tank sending unit 3 in accordance with the manufacturer's instructions. Route fuel line of fuel standpipe 1 along original vehicle fuel lines and secure using cable ties 2 [4].



Routing fuel line

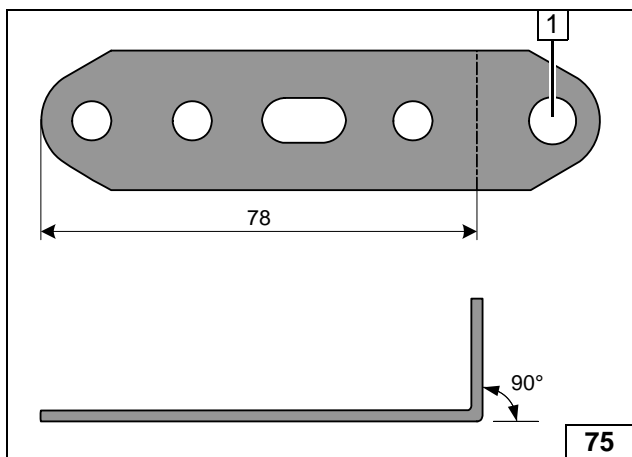

- 1 Drill out hole to 9 mm dia.

Preparing perforated bracket

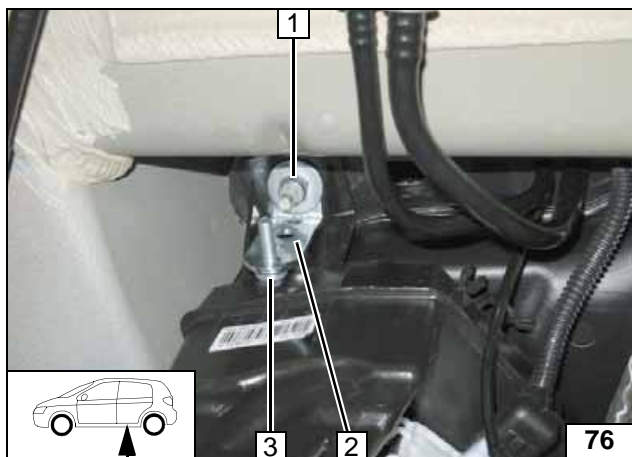

- 1 Original vehicle bolt
- 2 Perforated bracket
- 3 Mount M6x25 bolt

Installing perforated bracket

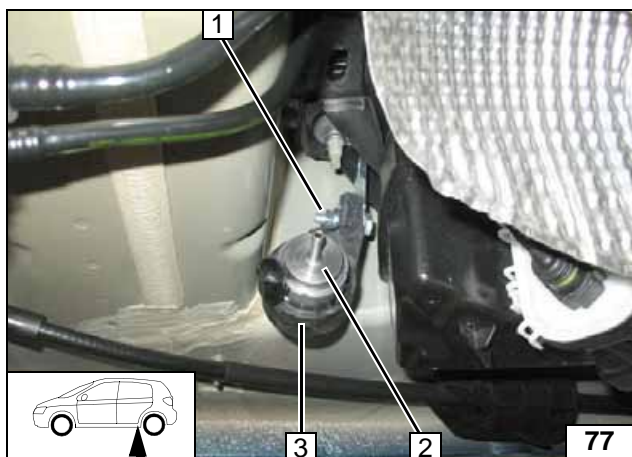

- 1 Flanged nut, support angle bracket
- 2 Metering pump
- 3 Metering pump mount



Installing metering pump

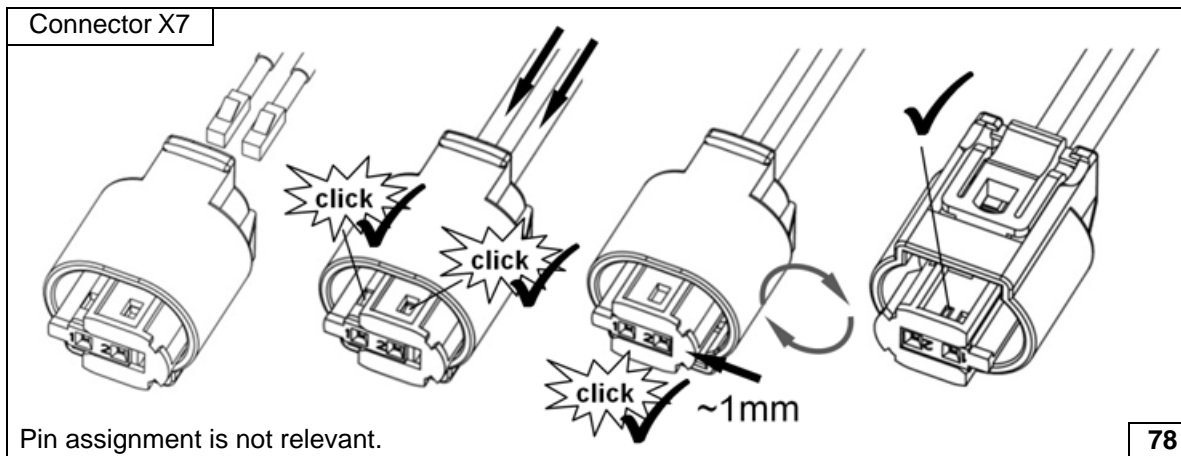

Completing metering pump connector

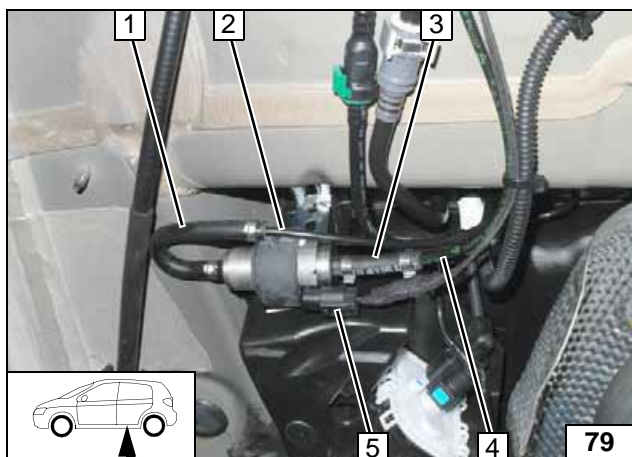

Check the position of the components; adjust if necessary. Check that they have freedom of movement.

- 1 180° moulded hose, 10mm dia. clamp [2x]
- 2 Fuel line of fuel standpipe
- 3 Hose section, 10mm dia. clamp [2x]
- 4 Fuel line of heater
- 5 Metering pump wiring harness, connector X7 mounted



Connecting metering pump



Coolant Circuit



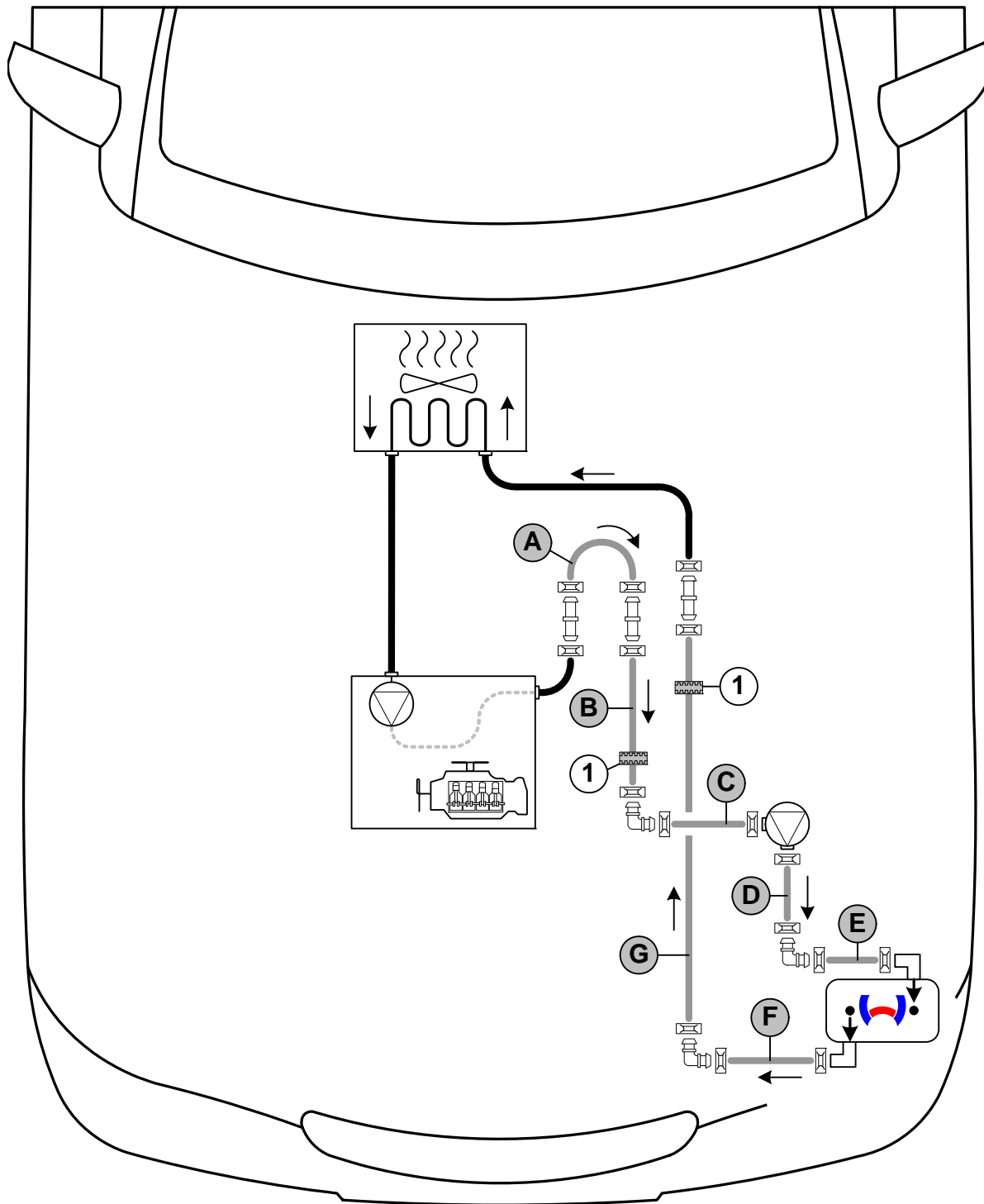

WARNING!

Any coolant running off should be collected in an appropriate container. Route hoses kink-free. Unless specified otherwise, always fasten using cable ties. Position clamps so that other hoses cannot be damaged. The heater must be filled with coolant when installing the hoses.

The connection should be modelled on an 'inline' circuit and based on the following diagram:



Hose routing diagram

All spring clips  = 25 mm dia. All connecting pipes  and  = 18x18 mm dia.
 1 = Black (sw) rubber isolator .



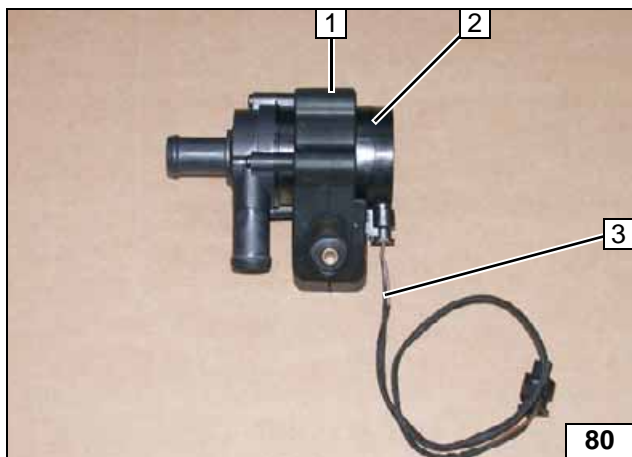

- 1 Circulating pump mount
- 2 Circulating pump
- 3 Circulating pump wiring harness

Premounting circulating pump

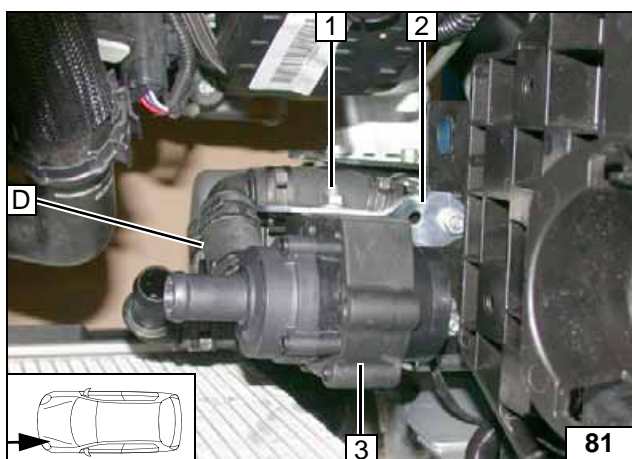

- 1 M6x25 bolt, flanged nut
- 2 Perforated bracket
- 3 Circulating pump mount

Installing circulating pump

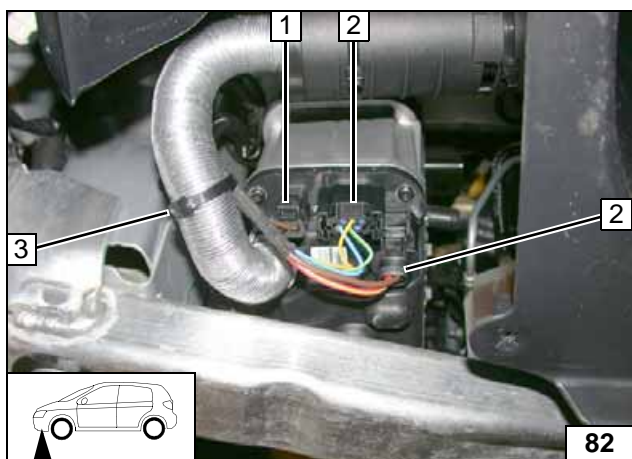

- 1 Connector of circulating pump wiring harness
- 2 Heater wiring harness connector [2x]
- 3 Cable tie

Installing wiring harnesses

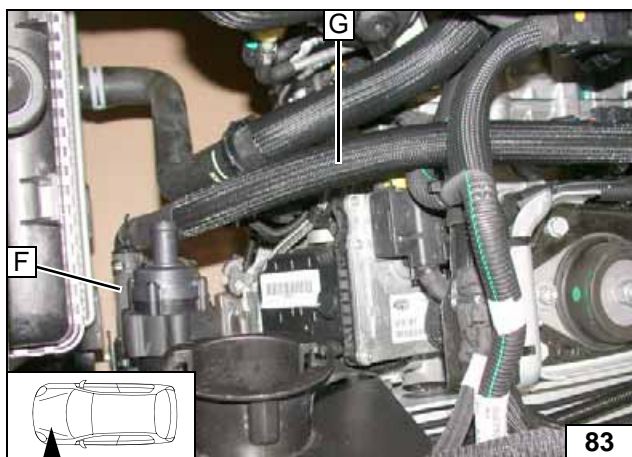

Connecting heater outlet

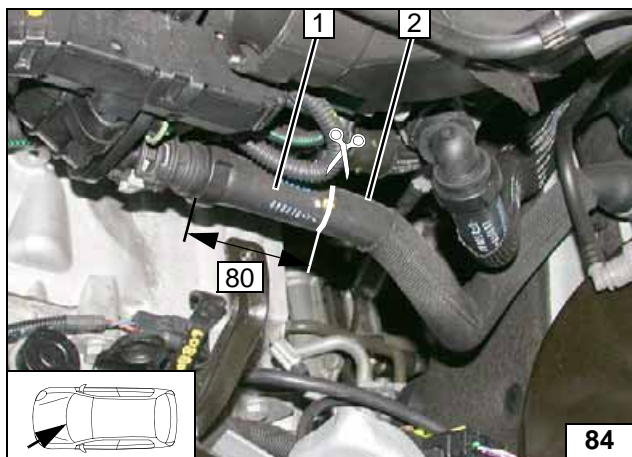

68 kW

Cut off hose of engine outlet/heat exchanger inlet at the marking.

- 1 Engine outlet hose section
- 2 Heat exchanger inlet hose section

Cutting point

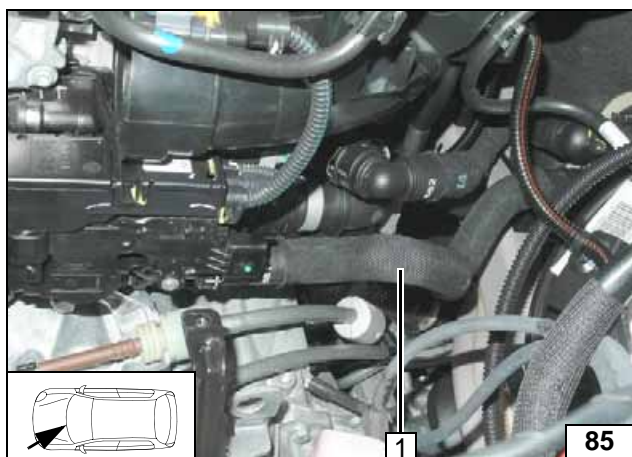

73 / 88 kW

Remove hose 1 from engine outlet/heat exchanger inlet.

Cutting point

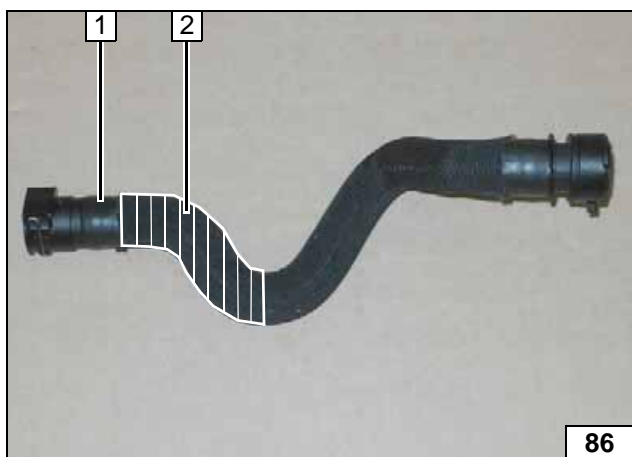

Remove marked section of original vehicle braided protection hose 2.

- 1 Hose of engine outlet / heat exchanger inlet

Removing original vehicle braided protection hose

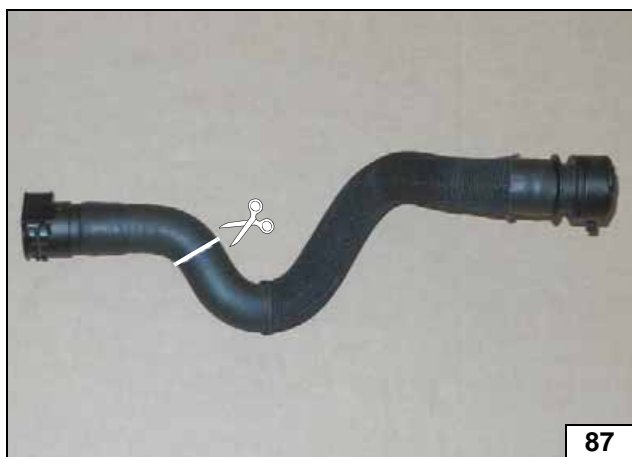

Cut off hose of engine outlet/heat exchanger inlet at the marking.

Cutting point



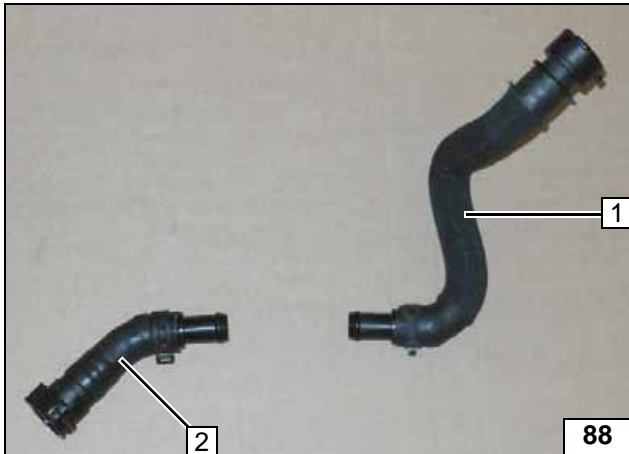

- 1 Heat exchanger inlet hose section
- 2 Engine outlet hose section

Premounting hose sections

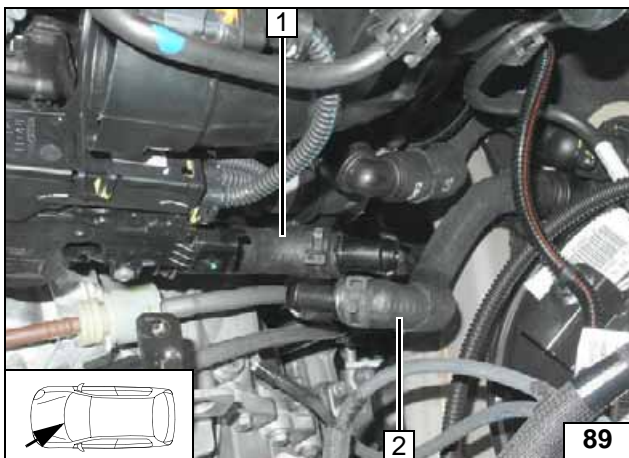

- 1 Engine outlet hose section
- 2 Heat exchanger inlet hose section

Installing hose sections

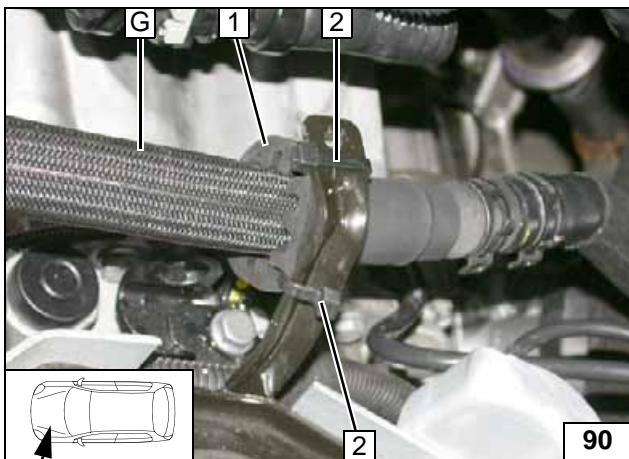

All vehicles

Figure shows 68 kW.

- 1 Slide on black (sw) rubber isolator and align
- 2 Cable tie [2x]



Routing in engine compartment

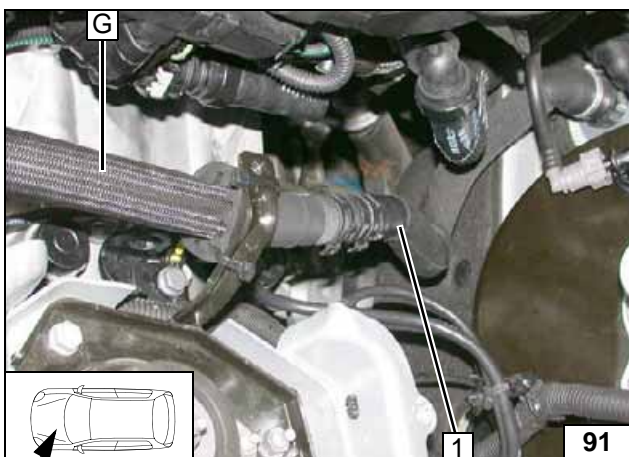

- 1 Heat exchanger inlet hose section

Connecting heat exchanger inlet

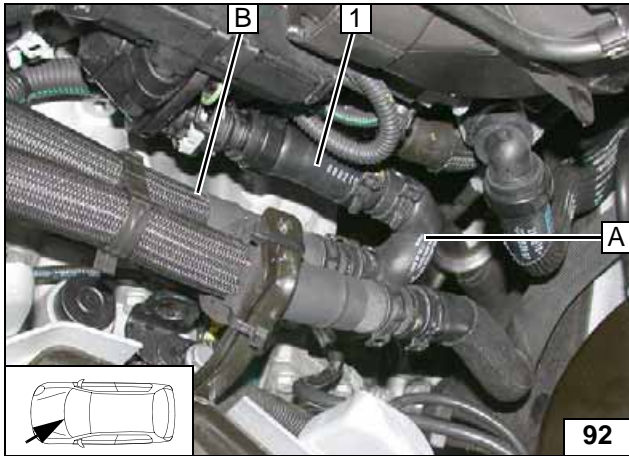

1 Engine outlet hose section

Connect-
ing engine
outlet

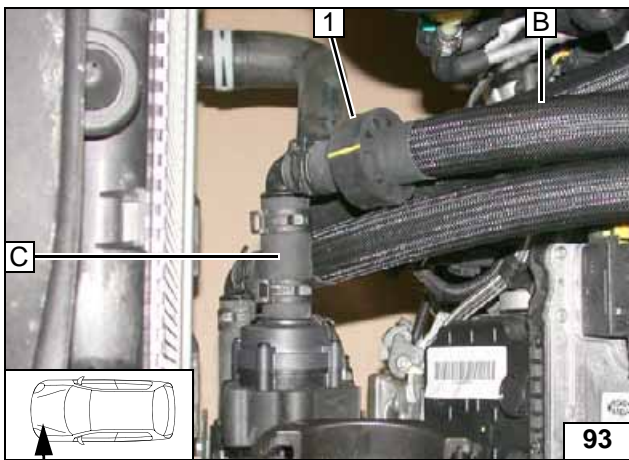

1 Slide on black (sw) rubber isolator and align

Connect-
ing circulat-
ing pump

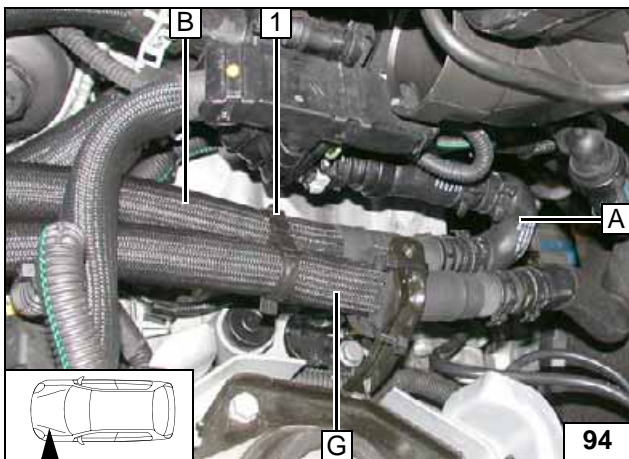

Align hoses. Ensure sufficient distance from neighbouring components.

1 Hose bracket



Installing
hose brack-
et

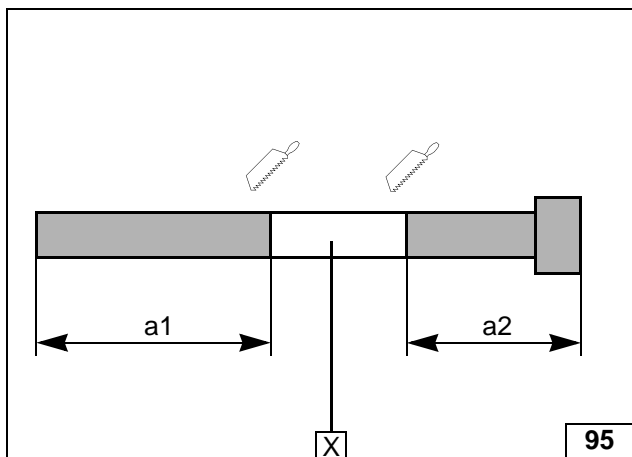
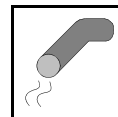

Exhaust Gas

a1 = 160

a2 = 100

X =



**Preparing ex-
haust pipe**

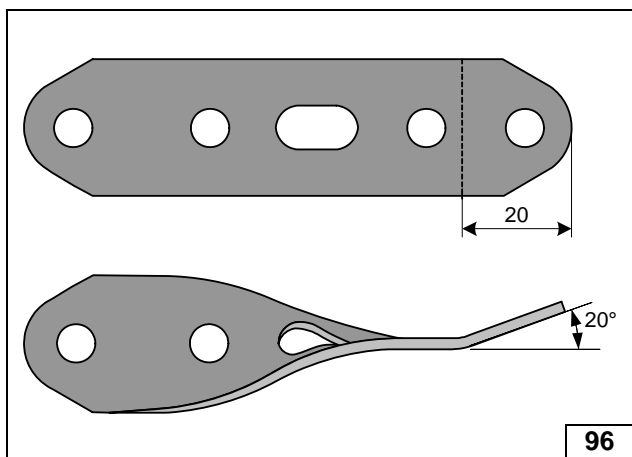

Perforated bracket of exhaust pipe **a2** only in case of plastic underride protection.

Twist perforated bracket by 90° around the longitudinal axis and angle down.



**Preparing
perforated
bracket of
exhaust
pipe a2**

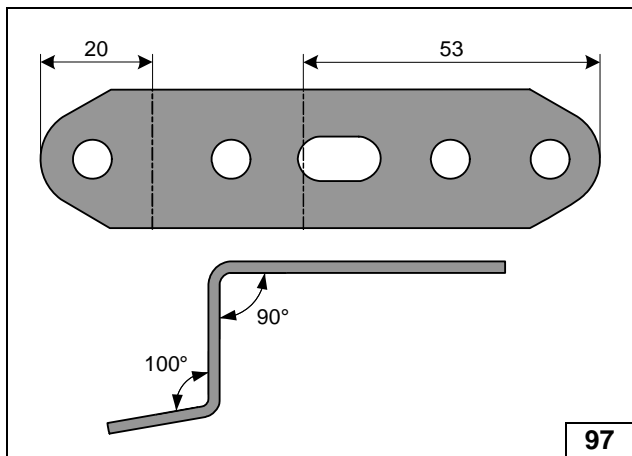

**Angling
down perfor-
ated brack-
et of
silencer**

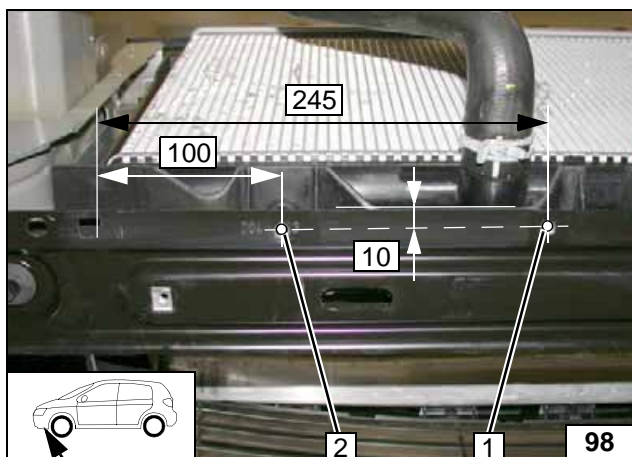

Hole in position **1** only in case of plastic underride protection.

1 7 mm dia. hole

2 7 mm dia. hole



**Holes in
cross mem-
ber**

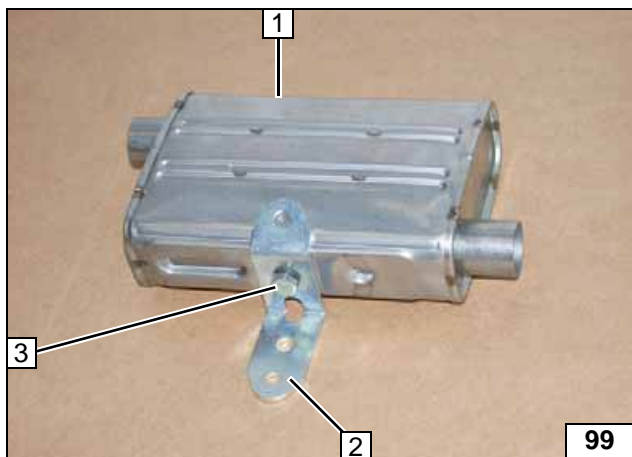
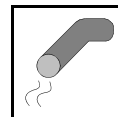

- 1 Silencer
- 2 Perforated bracket
- 3 M6x16 bolt, spring lockwasher

Premounting silencer

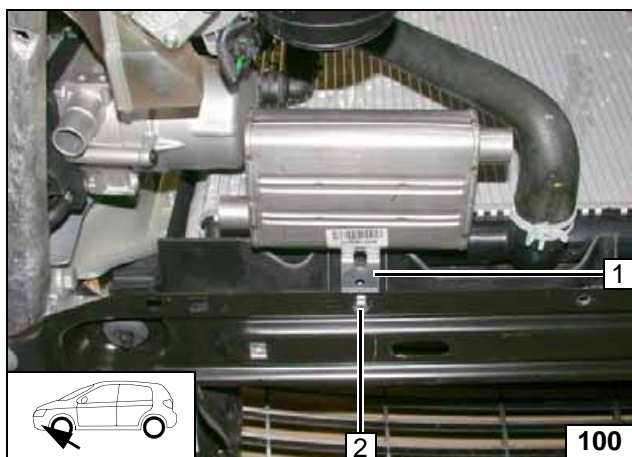

- 1 Perforated bracket
- 2 M6x20 bolt, flanged nut

Installing silencer

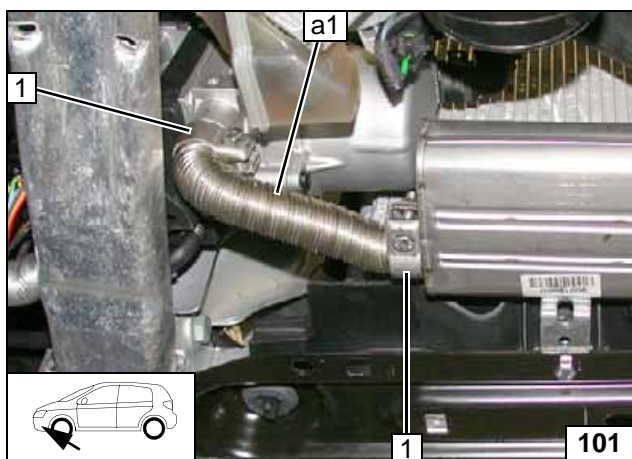

- 1 Hose clamp [2x]

Installing exhaust pipe a1

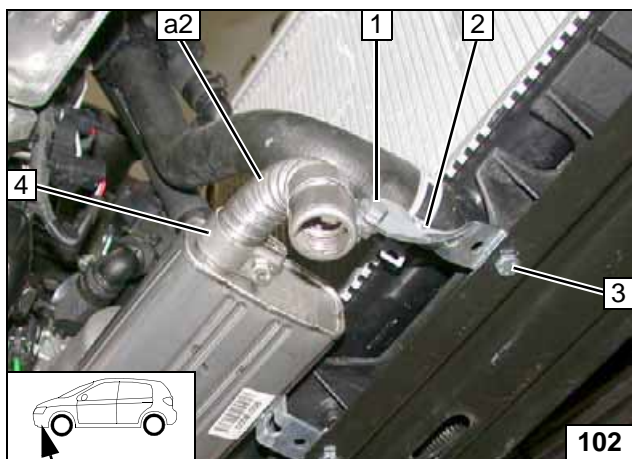

Perforated bracket **2** will be installed only in case of plastic underide protection; not if the underide protection is metallic. Ensure sufficient distance from neighbouring components, correct if necessary.

- 1 M6x20 bolt, p-clamp, flanged nut
- 3 M6x20 bolt, flanged nut
- 4 Hose clamp

Installing exhaust pipe a2



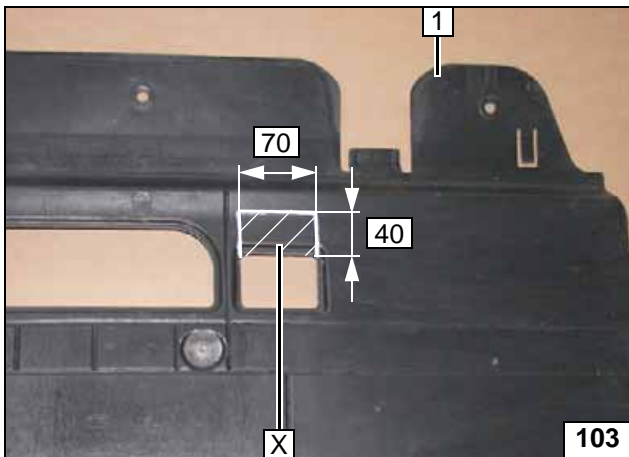

Final Work

In case of plastic underide protection

1 Underride protection

X =

Cutting out underide protection

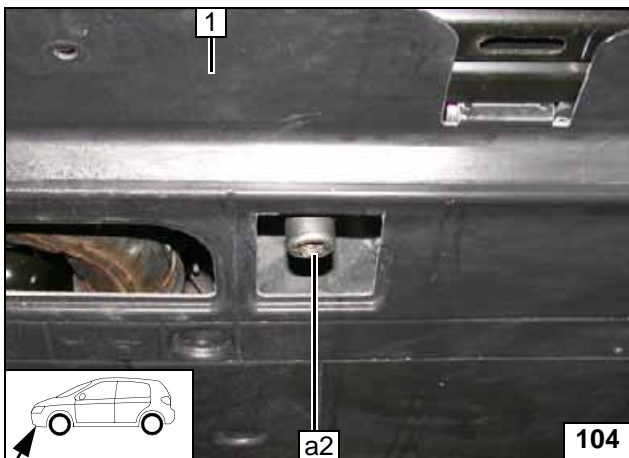

Install underide protection. Ensure sufficient distance between silencer and underide protection 1, correct if necessary. Align exhaust pipe a2 centrally in the recess of underide protection 1.



Aligning exhaust pipe a2

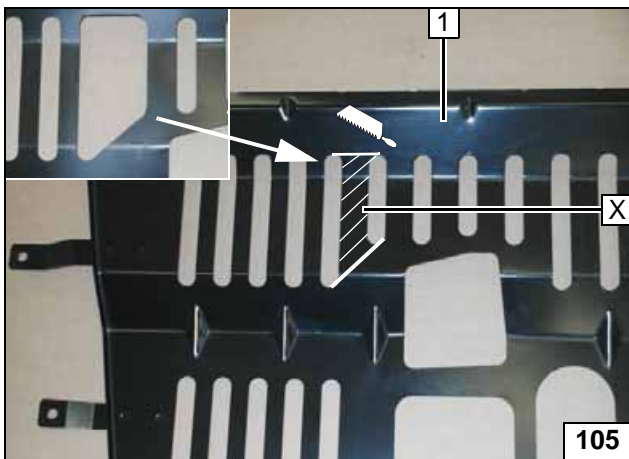

In case of metallic underide protection

1 Underride protection

X =

Cutting out underide protection

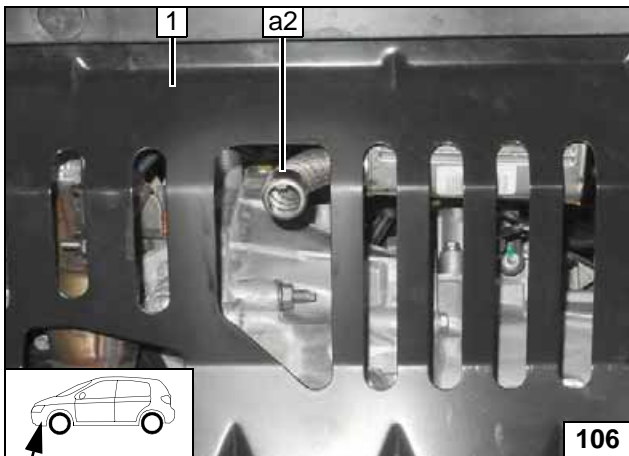

Install underide protection. Ensure sufficient distance between silencer and underide protection 1, correct if necessary. Align exhaust pipe a2 centrally in the recess of underide protection 1.



Aligning exhaust pipe a2

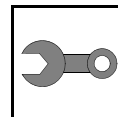

Final Work

WARNING!

Reassemble the components in reverse order. Check all hoses, clamps and all electrical connections for firm seating. Insulate and tie back loose lines.

Only use manufacturer-approved coolant. Spray the heater components with anti-corrosion wax (Tectyl 100K).



- **Connect the battery.**
- **Fill and bleed the coolant circuit according to the vehicle manufacturer's specifications.**
- **Program MultiControl CAR, teach Telestart transmitter.**
- **Make settings on A/C control panel according to the 'Operating Instructions for End Customer'.**
- **Place the 'Switch off parking heater before refuelling' caution label near the filler neck.**
- **For initial startup and function check, please see installation instructions.**



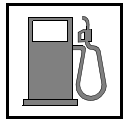

Fuel Standpipe Template

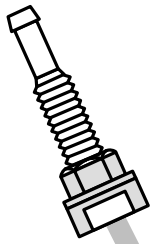

100mm



Scale 1:1

Compare size of printout with dimension lines.
Allowed tolerance a maximum of 2%.

Set the printer settings to 'no margin' or 'minimise margins' and 100% of the normal size.

100mm

0

Operation of Manual A/C for Citroen

Please remove page and add to the vehicle operating instructions.

Note:

We recommend matching the heating time to the driving time.

Heating time = driving time

Example:

For a driving time of approx. 20 min. (in one direction), we recommend not exceeding a switch-on time of 20 min.

Passenger compartment monitoring, if installed, must be deactivated in addition to the vehicle settings for the heating operation.

For instructions on deactivation, please refer to the operating instructions of the vehicle.

Before parking the vehicle, make the following settings:

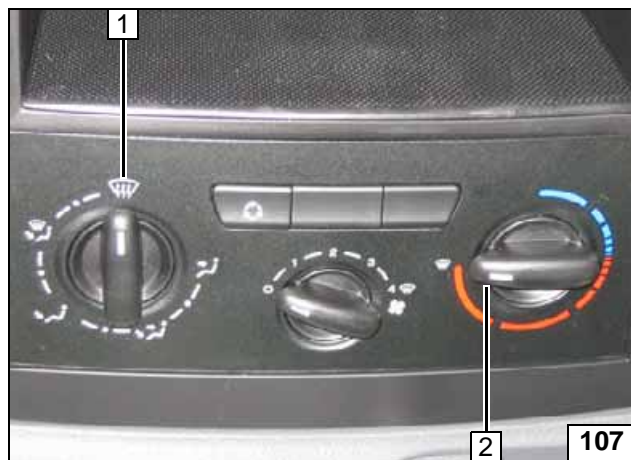

- 1 Air outlet to windscreen
- 2 Set temperature to 'max.'

A/C control panel

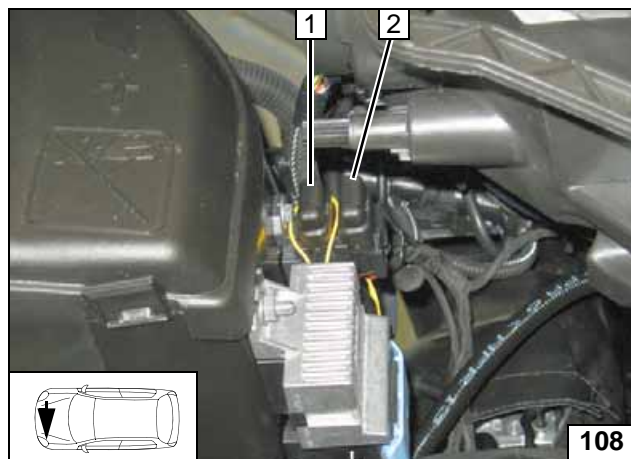

- 1 30A main fuse F2 of passenger compartment
- 2 20A heater fuse F1

Engine compartment fuses

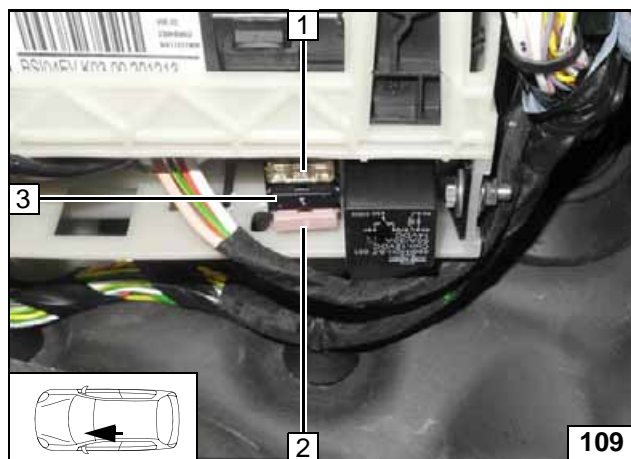

- 1 25A fan fuse F4
- 2 3A fan fuse F5
- 3 1A fuse F3 of heater control

Passenger compartment fuses



Operation of Automatic A/C for Citroen

Please remove page and add to the vehicle operating instructions.

Note:

We recommend matching the heating time to the driving time.
 Heating time = driving time

Example:

For a driving time of approx. 20 min. (in one direction), we recommend not exceeding a switch-on time of 20 min.

Passenger compartment monitoring, if installed, must be deactivated in addition to the vehicle settings for the heating operation.

For instructions on deactivation, please refer to the operating instructions of the vehicle.

Before parking the vehicle, make the following settings:

No specific settings necessary.



A/C control panel

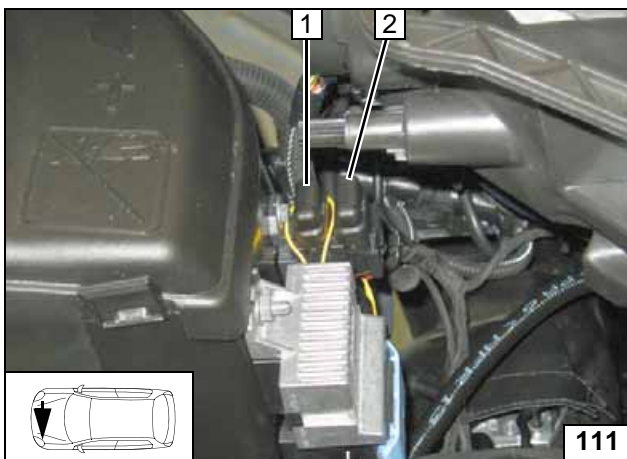

- 1 30A main fuse F2 of passenger compartment
- 2 20A heater fuse F1

Engine compartment fuses

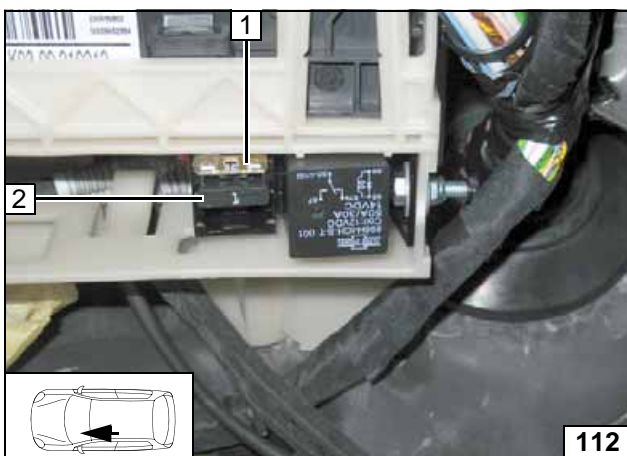

- 1 25A fan fuse F4
- 2 1A fuse F3 of heater control

Passenger compartment fuses



Operation of Manual A/C for Peugeot

Please remove page and add to the vehicle operating instructions.

Note:

We recommend matching the heating time to the driving time.

Heating time = driving time

Example:

For a driving time of approx. 20 min. (in one direction), we recommend not exceeding a switch-on time of 20 min.

Passenger compartment monitoring, if installed, must be deactivated in addition to the vehicle settings for the heating operation.

For instructions on deactivation, please refer to the operating instructions of the vehicle.

Before parking the vehicle, make the following settings:

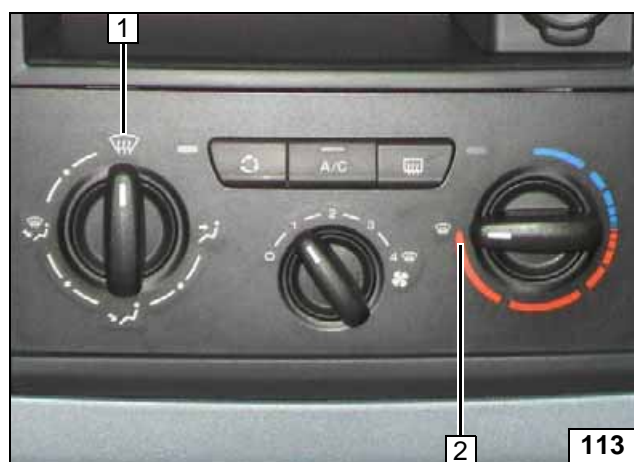

- 1 Air outlet to windscreen
- 2 Set temperature to 'max.'

A/C control panel

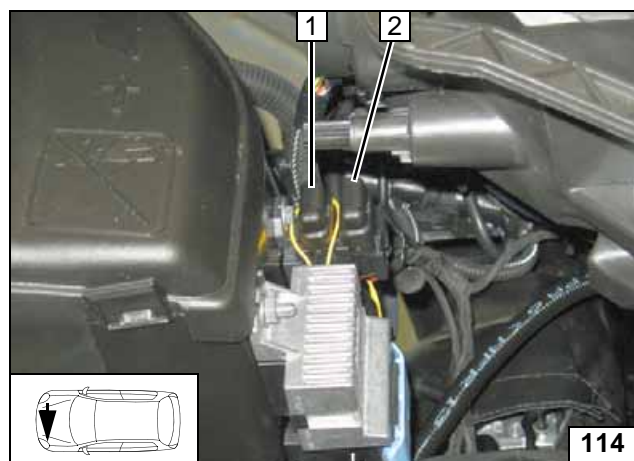

- 1 30A main fuse F2 of passenger compartment
- 2 20A heater fuse F1

Engine compartment fuses

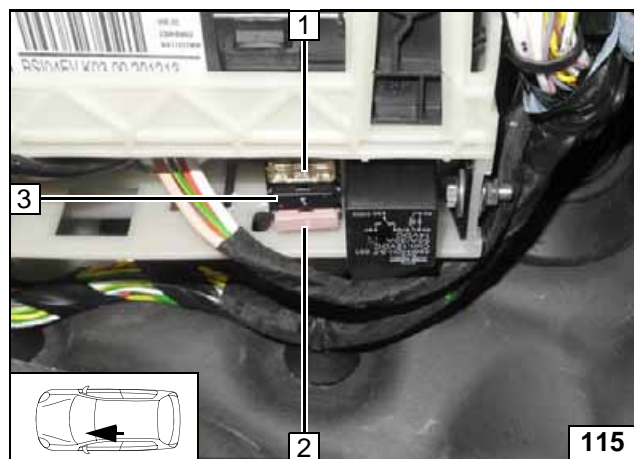

- 1 25A fan fuse F4
- 2 3A fan fuse F5
- 3 1A fuse F3 of heater control

Passenger compartment fuses



Operation of Automatic A/C for Peugeot

Please remove page and add to the vehicle operating instructions.

Note:

We recommend matching the heating time to the driving time.
 Heating time = driving time

Example:

For a driving time of approx. 20 min. (in one direction), we recommend not exceeding a switch-on time of 20 min.

Passenger compartment monitoring, if installed, must be deactivated in addition to the vehicle settings for the heating operation.

For instructions on deactivation, please refer to the operating instructions of the vehicle.

Before parking the vehicle, make the following settings:

No specific settings necessary.



116

A/C control panel

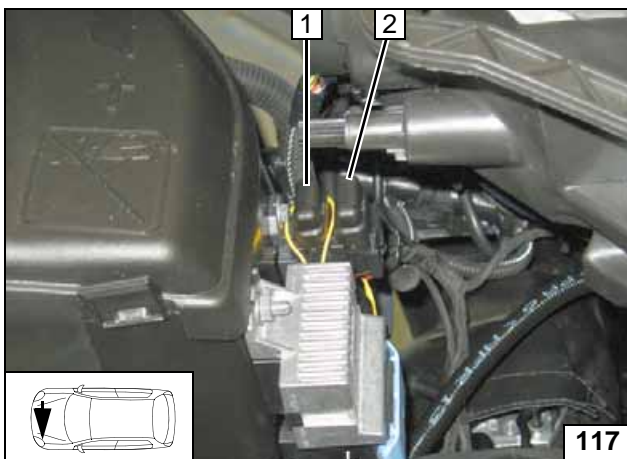

117

- 1 30A main fuse F2 of passenger compartment
- 2 20A heater fuse F1

Engine compartment fuses

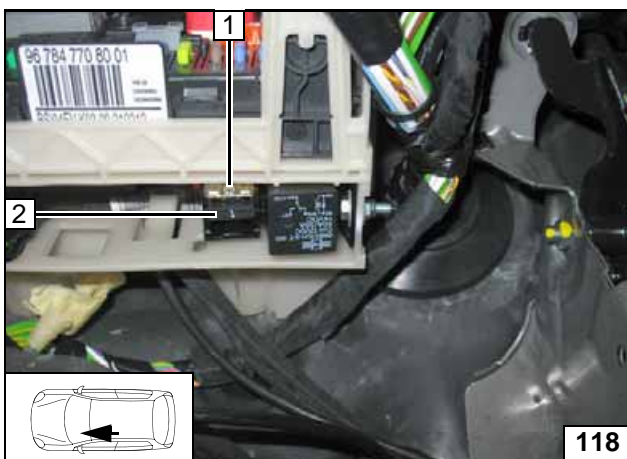

118

- 1 25A fan fuse F4
- 2 1A fuse F3 of heater control

Passenger compartment fuses

