

WaterHeater

Thermo Top Evo Parking Heater



Installation Documentation Chevrolet Captiva / Opel Antara

Validity

Chevrolet

Manufacturer	Model	Type	EG-BE No. / ABE
Chevrolet	Captiva	KLAC	e4 * 2001 / 116 * 0113 * ...

Motorisation	Fuel	Transmission type	Output in kW	Displacement in cm ³	Engine code
2.2 D	Diesel	6-gear SG	120	2231	Z22D1
2.2 D	Diesel	6-speed AG	120	2231	Z22D1
2.2 D	Diesel	6-gear SG	135	2231	Z22D1

Opel

Manufacturer	Model	Type	EG-BE No. / ABE
Opel	Antara	L-A	e4 * 2001 / 116 * 0118 * ...

Motorisation	Fuel	Transmission type	Output in kW	Displacement in cm ³	Engine code
2.2 D	Diesel	6-gear SG	120	2231	A22DM
2.2 D	Diesel	6-speed AG	120	2231	A22DM
2.2 D	Diesel	6-speed AG	135	2231	A22DMH

SG = Manual Transmission
AG = Automatic Transmission

**Starting with model year
2011**

Left-hand drive vehicle

Verified equipment variants: Automatic air-conditioning
Front fog light
Headlight washer system
Xenon for the Opel Antara
Daytime running lights
2 WD / 4 WD
Start - Stop

Not verified: Manual air-conditioning
Passenger compartment monitoring

Total installation time: approx. 9 hours

Chevrolet Captiva / Opel Antara

Table of Contents

Validity	1	Preparing Heater	14
Necessary Components	2	Preparing Bracket	16
Installation Overview	2	Preparing Installation Location	17
Notes on Total Installation Time	2	Installing Heater	19
Notes on Operating and Installation Instructions	3	Fuel	20
Notes on Validity	4	Coolant Circuit	23
Technical Instructions	4	Exhaust Gas	30
Explanatory Notes on Document	4	Final Work	33
Preliminary Work	5	Fuel Standpipe Template	34
Installation Location of Heater	5	Template of bracket	35
Preparing Electrical System	6	Operating Instructions for Chevrolet Captiva	36
Electrical System	8	Operating Instructions for Opel Antara	38
Fan Controller	9		
Digital Timer	12		
Remote Option (Telestart)	12		
Remote Option (Thermo Call TC3)	13		

Necessary Components

- Basic delivery scope for *Thermo Top Evo* based on price list
- Installation kit for Chevrolet Captiva / Opel Antara 2011 Diesel: **1318921A**
- Heater control in accordance with price list and upon consultation with end customer
- In case of Telestart, control light in accordance with price list and upon consultation with end customer

Installation Overview

Legend:

1. Heater
2. Fuse holder of engine compartment
3. Relay and fuse holder of passenger compartment
4. IPCU
5. Circulating pump
6. Digital timer
7. Metering pump

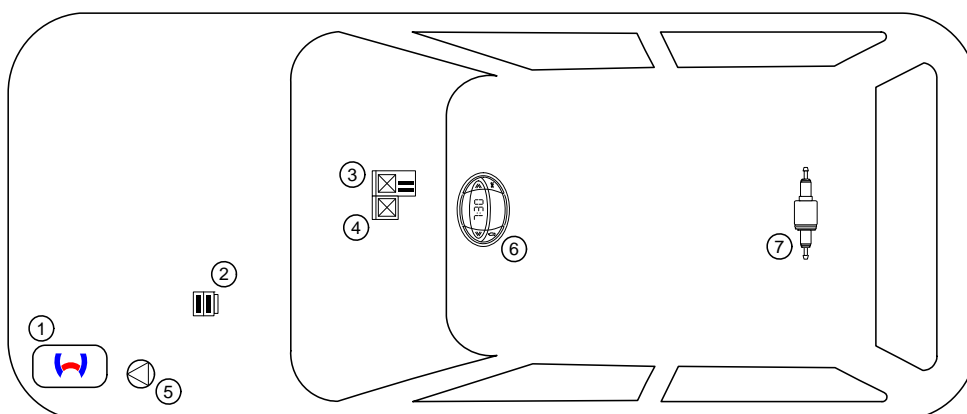

Notes on Total Installation Time

The total installation time includes the time needed for mounting and demounting of the vehicle-specific components, the heater specific installation time and all other times required for the system integration and initial start-up of the heater.

The total installation time may vary for vehicle equipment other than provided.

Notes on Operating and Installation Instructions

1 Important Information (not complete)

1.1 Installation and Repair



The improper installation or repair of Webasto heating and cooling systems can cause fire or the leakage of deadly carbon monoxide, leading to serious injury or death.



To install and repair Webasto heating and cooling systems you need to have completed a special company training course and have the appropriate technical documentation, special tools and special equipment.



Installation and repair may ONLY be carried out by persons trained and certified in a Webasto training course. NEVER try to install or repair Webasto heating or cooling systems if you have not completed a Webasto training course, you do not have the necessary technical skills and you do not have the technical documentation, tools and equipment available to ensure that you can complete the installation and repair work properly.

Only use genuine Webasto parts. See the Webasto air and water heaters accessories catalogue for this purpose.

1.2 Operation

To ensure safe operation, we recommend having the heater checked every two years by an authorised Webasto dealer, especially when used over a long period and/or under extreme environmental conditions.

Do not operate the heater in closed rooms due to the danger of poisoning and suffocation.

Always switch off the heater before refuelling.

The heater may only be used with the prescribed fuel Diesel (DIN EN 590) or petrol (DIN EN 227).

The heater may not be cleaned with a high-pressure cleaner.

1.3 Please note

ALWAYS follow all Webasto installation and operating instructions and observe all warnings.

To become familiar with and understand all functions and properties of the heater, the operating instructions must be read carefully and observed at all times.

For proper, safe installation and repair work, the installation instructions with all warnings and safety information must be carefully read and observed at all times. Please always contact a workshop authorised by Webasto for all installation and repair work.

Important

Webasto shall assume no liability for defects, damage and injuries resulting from a failure to observe the installation, repair and operating instructions of the information contained in them.

This liability exclusion particularly applies to improper installations and repairs, installations and repairs by untrained persons or in the case of a failure to use genuine spare parts.

The liability due to culpable disregard to life, limb or health and due to damage or injuries caused by a wilful or reckless breach of duty remain unaffected, as does the obligatory product liability.

Installation should be carried out according to the general, standard rules of technology. Unless specified otherwise, fasten hoses, lines and wiring harnesses to original vehicle lines and wiring harnesses using cable ties. Insulate loose wires and tie back. Connectors of electronic components have to audibly snap into place when inserting them during installation.

Sharp edges should be fitted with rub protection. Spray unfinished body areas, e.g. drilled holes, with anti-corrosion wax (Tectyl 100K, Order No. 111329).

Observe the instructions and guidelines of the respective vehicle manufacturer for demounting and mounting vehicle specific components!

The initial startup is to be executed with the Webasto Thermo Test Diagnosis.

When installing an IPCU, the corresponding settings must be checked or adjusted before the installation.

2 Statutory regulations governing installation

Guidelines	Thermo Top Evo
Heating Directive ECE R122	E1 00 0258
EMC Directive ECE R10	E1 03 5627

Note

The regulations of these guidelines are binding in the scope of the Directive 70/156/EEC and/or 2007/46/EC (for new vehicle models from 29/04/2009) and should also be observed in countries in which there are no special regulations.

Important

Failure to follow the installation instructions will result in the invalidation of the type approval for the heater and therefore invalidation of the general **homologation of the vehicle**.

Note

For vehicles with an EU permit, no entry in accordance with § 19 Sub-Section 4 of Annex VIII b to the Road Traffic Act is required.

2.1 Excerpt from the directive 2001/56/EC Appendix VII for the installation of the heater

Beginning of excerpt.

ANNEX VII

REQUIREMENTS FOR COMBUSTION HEATERS AND THEIR INSTALLATION

1. GENERAL REQUIREMENTS

1.7.1. A clearly visible operation indicator in the operator's field of view shall inform when the combustion heater is switched on or off.

2. VEHICLE INSTALLATION REQUIREMENTS

2.1. Scope

2.1.1. Subject to paragraph 2.1.2. combustion heaters shall be installed according to the requirements of this Annex.

2.1.2. Vehicles of category O having liquid fuel heaters are deemed to comply with the requirements of this Annex.

2.2. Positioning of the heater

2.2.1. Body sections and any other components in the vicinity of the heater must be protected from excessive heat and the possibility of fuel or oil contamination.

2.2.2. The combustion heater shall not constitute a risk of fire, even in the case of overheating. This requirement shall be deemed to be fulfilled if the installation ensures an adequate distance to all parts and suitable ventilation, by the use of fire resistant materials or by the use of heat shields.

2.2.3. In the case of M2 and M3 vehicles, the heater must not be positioned in the passenger compartment. However, an installation in an effectively sealed envelope which also complies with the conditions in paragraph 2.2.2 may be used.

2.2.4. The label referred to in paragraph 1.4 or a duplicate, must be positioned so that it can be easily read when the heater is installed in the vehicle.

2.2.5. Every reasonable precaution should be taken in positioning the heater to minimise the risk of injury and damage to personal property.

2.3. Fuel supply

2.3.1. The fuel filler must not be situated in the passenger compartment and must be provided with an effective cap to prevent fuel spillage

2.3.2. In the case of liquid fuel heaters, where a supply separate to that of the vehicle is provided, the type of fuel and its filler point must be clearly labelled

2.3.3. A notice, indicating that the heater must be shut down before refuelling, must be affixed to the fuelling point. In addition a suitable instruction must be included in the manufacturer's operating manual.

2.4. Exhaust system

2.4.1. The exhaust outlet must be located so as to prevent emissions from entering the vehicle through ventilators, heated air inlets or opening windows.

2.5. Combustion air inlet

2.5.1. The air for the combustion chamber of the heater must not be drawn from the passenger compartment of the vehicle.

2.5.2. The air inlet must be so positioned or guarded that blocking by rubbish or luggage is unlikely.

2.6. Heating air inlet

2.6.1. The heating air supply may be fresh or recirculated air and must be drawn from a clean area not likely to be contaminated by exhaust fumes emitted either by the propulsion engine, the combustion heater or any other vehicle source.

2.6.2. The inlet duct must be protected by mesh or other suitable means.

2.7. Heating air outlet

2.7.1. Any ducting used to route the hot air through the vehicle must be so positioned or protected that no injury or damage could be caused if it were to be touched.

2.7.2. The air outlet must be so positioned or guarded that blocking by rubbish or luggage is unlikely.

End of excerpt.

In multilingual versions the German language is binding.

Chevrolet Captiva / Opel Antara

Notes on Validity

This installation documentation applies to the vehicles Chevrolet Captiva / Opel Antara Diesel - see page 1 for validity - starting with model year 2011 and later, if technical changes to the vehicle do not influence the installation, excluding any liability claims. Depending on the vehicle version and equipment, modifications may be necessary during installation with respect to these "installation instructions".

Vehicle and motor types, equipment variants and other specifications that were not listed in this installation documentation have not been tested. However, installation according to this installation documentation may be possible.

Technical Instructions

Special tools

- Hose clamp pliers for self-clamping hose clamps
- Hose clamp pliers for Clic hose clamps of type W
- Automatic wire stripper 0.2 - 6mm²
- Crimping pliers for cable lug / tab connector 0.5 - 6mm²
- Torque wrench for 2.0 - 10 Nm
- Hose clamping pliers
- Metric thread-setter kit
- Webasto Thermo Test Diagnosis with current software

Dimensions

- All dimensions are in mm.

Tightening torque values

- Tightening torque values of 5x13 heater bolts and heater stud bolts = 8Nm.
- Tightening torque value of 5x15 bolt of water connection piece retaining plate = 7Nm.
- Tighten other bolt connections in accordance with manufacturer's instructions or in accordance with state-of-the-art-technology.

Explanatory Notes on Document

You will find an identification mark on the outside top right corner of the page in question to provide you with a quick overview of the individual working steps.

Special features are highlighted using the following symbols:

Mechanical system



Electrical system



Coolant circuit

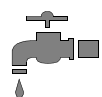

Combustion air

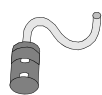

Fuel



Exhaust gas



Software



Specific risk of injury or fatal accidents



Specific risk of damage to components



Specific risk of fire or explosion.



Reference to general installation instructions of the Webasto components or to the manufacturer's vehicle-specific documents.



Reference to a special technical feature.



The arrow in the vehicle icon indicates the position on the vehicle and the viewing angle

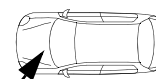

Chevrolet Captiva / Opel Antara

Preliminary Work

Vehicle

- Open the fuel tank cap.
- Ventilate the fuel tank.
- Close the fuel tank cap again.
- Depressurise the cooling system.
- Disconnect the battery and remove it completely, including the carrier.
- Remove the engine compartment fuse and relay box.
- Remove the engine control unit.
- Detach the coolant expansion tank and set it aside.
- Remove the upper bumper trim (retaining rail of the radiator grill).
- Remove the left-hand headlight.
- Remove horn.
- Remove the front underride protection.
- Remove the glove compartment (only with Telestart).
- Detach the passenger compartment fuse and relay carrier and set it aside.
- Fold up the rear bench seat.
- Open the tank-fitting service lid.

Heater

- Remove years that do not apply from the type and duplicate label.
- Attach the duplicate label (type label) in the appropriate place in the engine compartment.



Installation Location of Heater

Figure shows Chevrolet Captiva.

- 1 Heater



Installation location

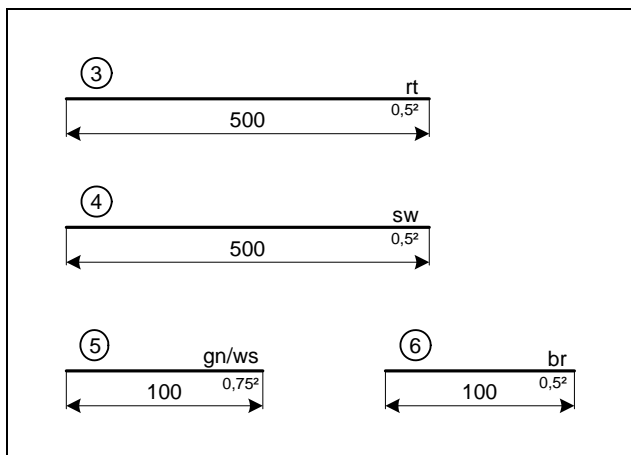

Preparing Electrical System

Wire sections retain their numbering throughout the entire document.



Preparing wires

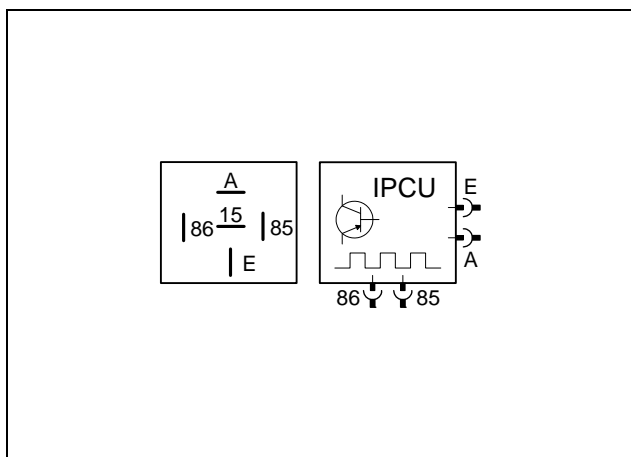

View of IPCU on contact side. The settings of the IPCU are to be checked before the heater start-up, and adjusted if necessary.



IPCU check

IPCU settings:

- Duty Cycle: 100% (DC)
- Frequency: 1000Hz
- Voltage: 3.6V
- Function: High Side

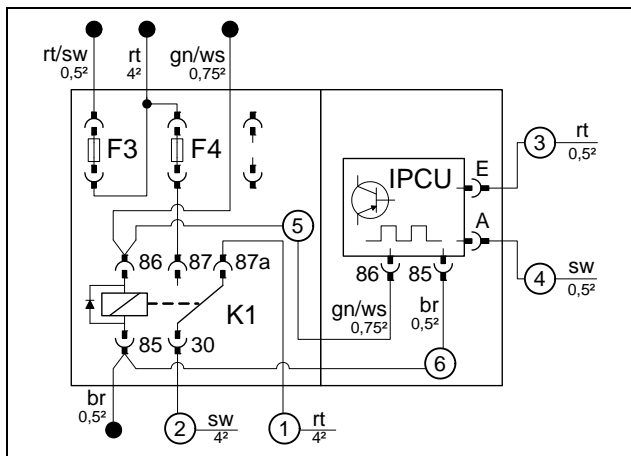

Connect the wires of K1 relay socket and IPCU. Cut provided protective sleeving appropriately to length. Pull wire sections 3 and 4 into a protective sleeving.



Preparing K1-relay and IPCU, inserting F4

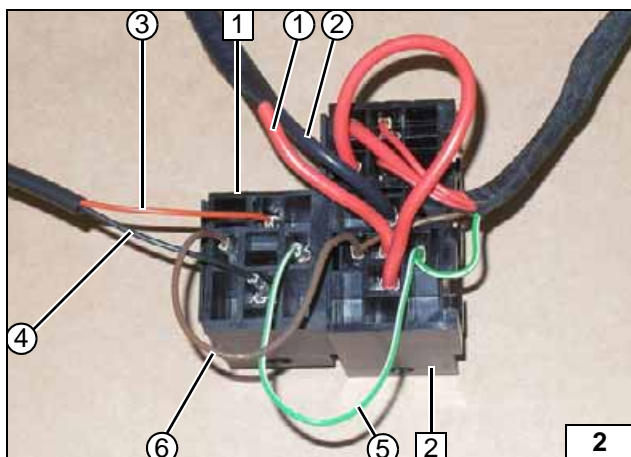

Snap IPCU socket 1 together with passenger compartment relay and fuse holder 2.



Preparing relay and fuse holder of passenger compartment

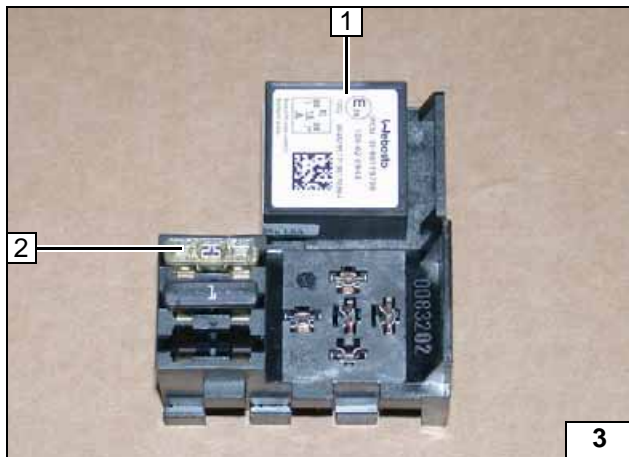

K1 relay will only be inserted after installing the relay and fuse holder.

- 1 IPCU mounted
- 2 25A fuse F4 inserted



Preparing relay and fuse holder of passenger compartment

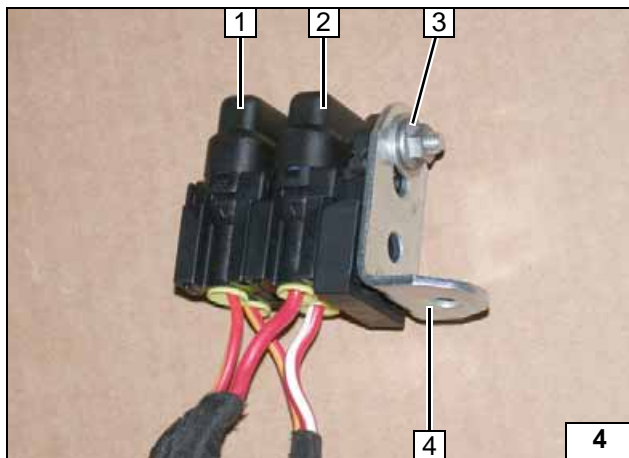

- 1 20A heater fuse F1
- 2 30A main fuse F2 of passenger compartment
- 3 M5x16 bolt, washer [2x], fuse holder retaining plate, nut
- 4 Angle bracket

Preparing engine compartment fuse holder

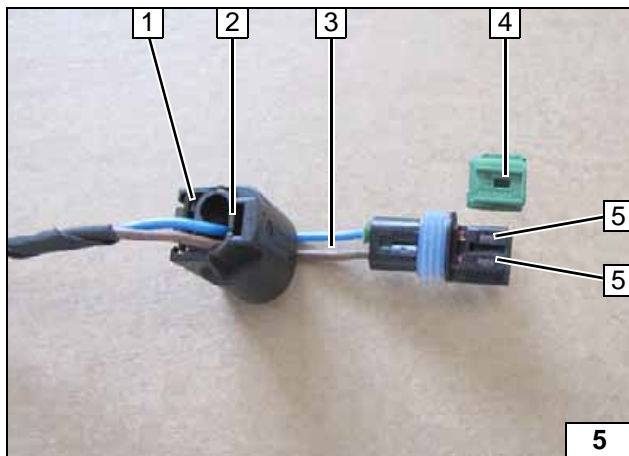

Complete connector of metering pump again after routing. Pin assignment is not relevant.

- 1 Connector housing
- 2 Lock
- 3 Blue (bl) and brown (br) wires
- 4 Coding
- 5 Timer lock



Dismantling connector



Electrical System



Earth wire

- 1 Earth wire on negative terminal of battery

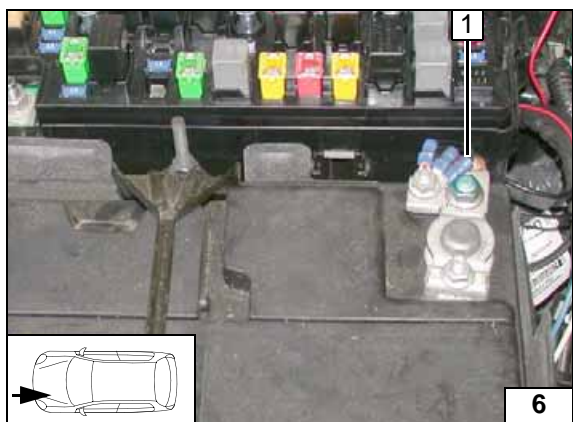

Positive wire

- 1 Positive wire on positive distributor

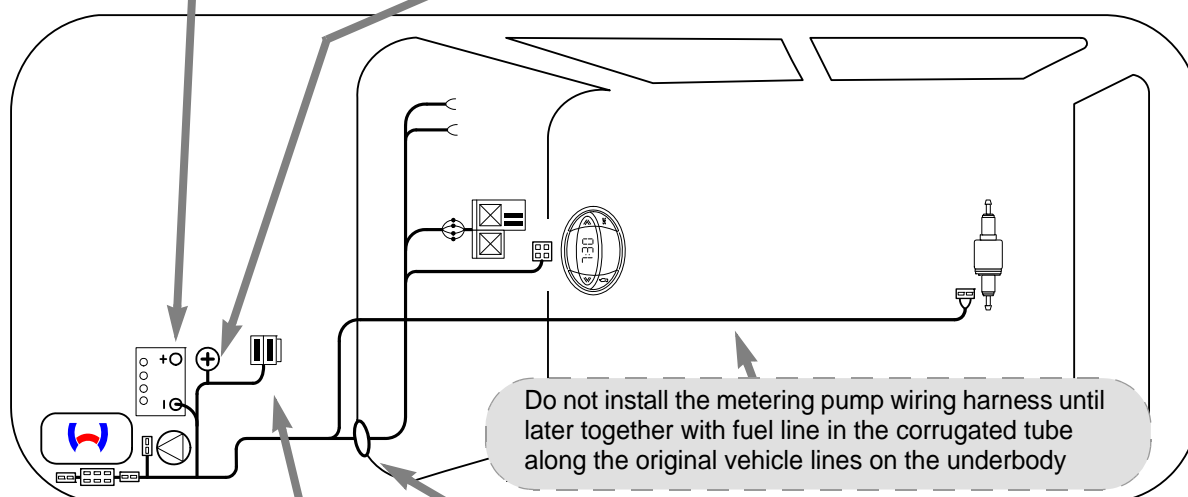
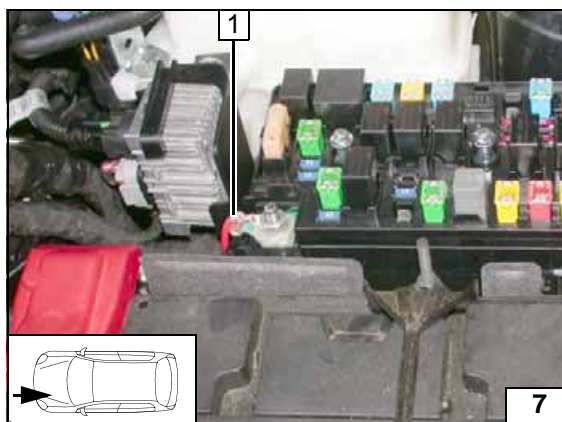

Wiring harness routing diagram

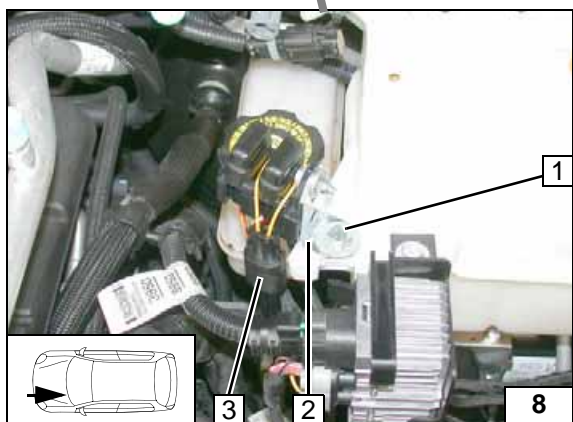

Fuse holder of engine compartment

- 1 M6x20 bolt, large diameter washer, existing threaded hole
- 2 Angle bracket
- 3 Diagnosis connector

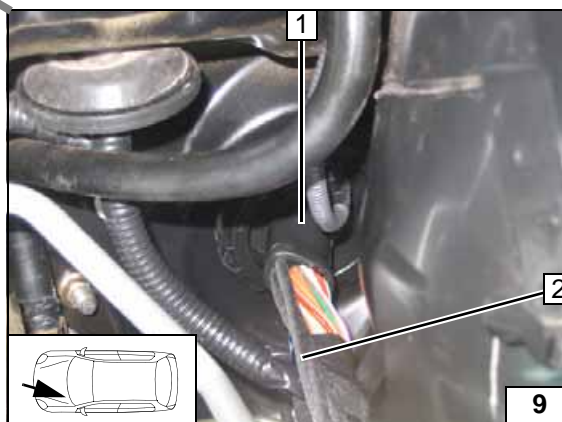

Wiring harness pass through

- 1 Protective rubber plug
- 2 Heater wiring harnesses, heater control

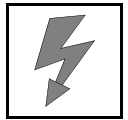

Fan Controller

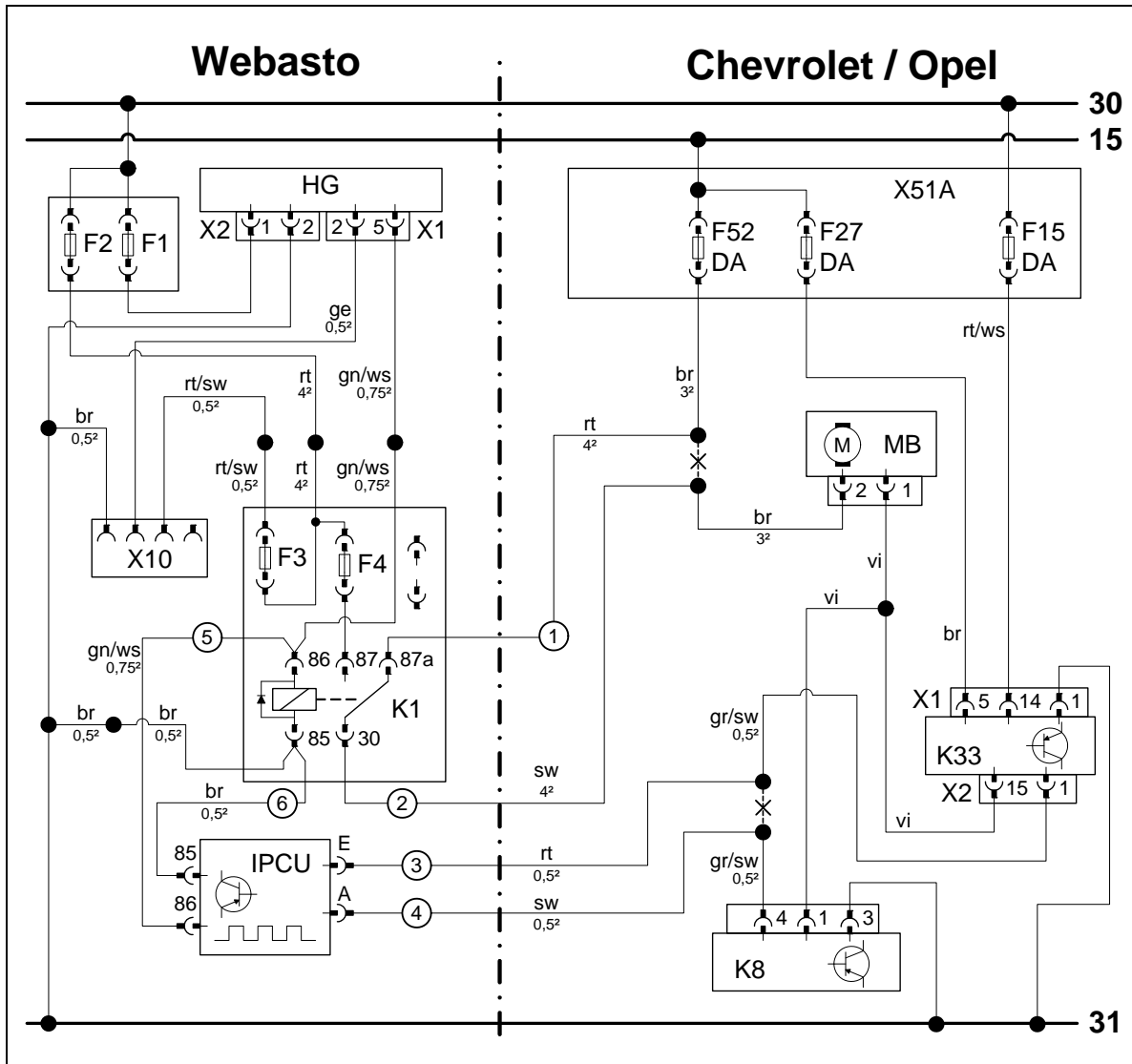

Wiring diagram

Webasto components		Vehicle components		Colours and symbols	
HG	Heater TT-Evo	X51A	Fuse box of instrument panel	rt	red
X1	6-pin heater connector	F52DA	40A fuse	sw	black
X2	2-pin heater connector	F27DA	10 A fuse	ge	yellow
X10	4-pin connector of heater control	F15DA	15A fuse	gn	green
K1	Fan relay	MB	Fan motor	vi	violet
F1	20A fuse	X1	K33 connector	ws	white
F2	30A fuse	K33	A/C control unit	br	brown
F3	1A fuse	X2	K33 connector	GR	grey
F4	25A fuse	K8	Fan controller		
IPCU	Pulse width modulator				
IPCU settings:					
Duty Cycle: 100% (DC)					
Frequency: 1000Hz					
Voltage: 3.6V					
Function: High side					
				X	Cutting point
Wiring colours may vary.					

Legend

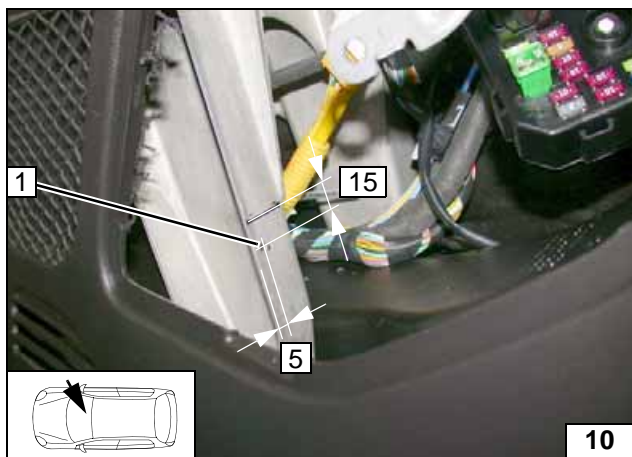

1 5.5mm dia. hole

Hole in centre console

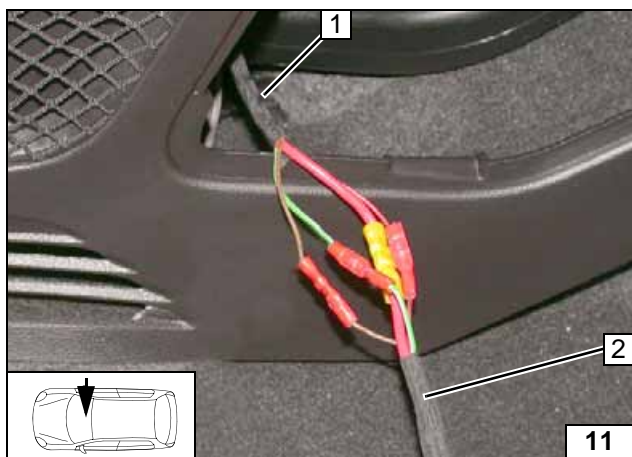

Connect wiring harness of passenger compartment relay and fuse holder 2 with wiring harness of heater 1 according to the wiring diagram using same-colour wires.



Connecting wiring harnesses



- 1 Relay and fuse holder of passenger compartment
- 2 M5x16 bolt, large diameter washer [2x], nut

Mounting relay and fuse holder of passenger compartment

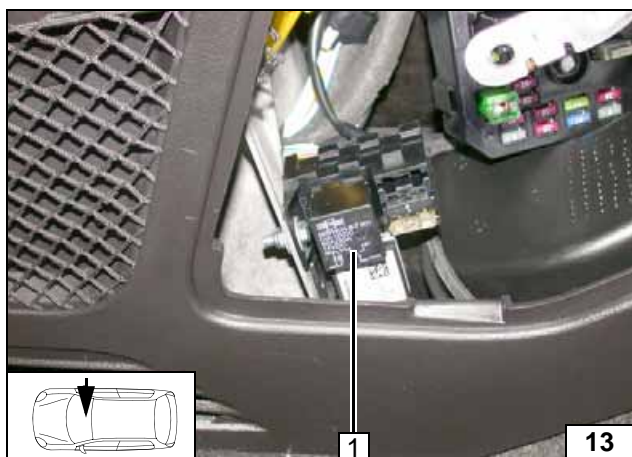

1 K1-relay

Inserting K1 relay

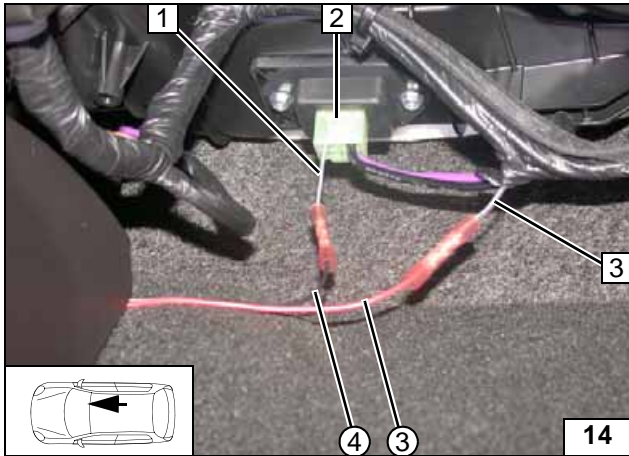

Connection to 4-pin connector **2** from fan controller. Produce connections as shown in wiring diagram.



- 1 Grey/black (gr/sw) wire of 4-pin connector, Pin 4
- 3 Grey/black (gr/sw) wire of A/C control panel K33 X2/1
- ③ Red (rt) wire from IPCU/E
- ④ Black (sw) wire from IPCU/A

**Connec-
tion of fan
controller
K8**

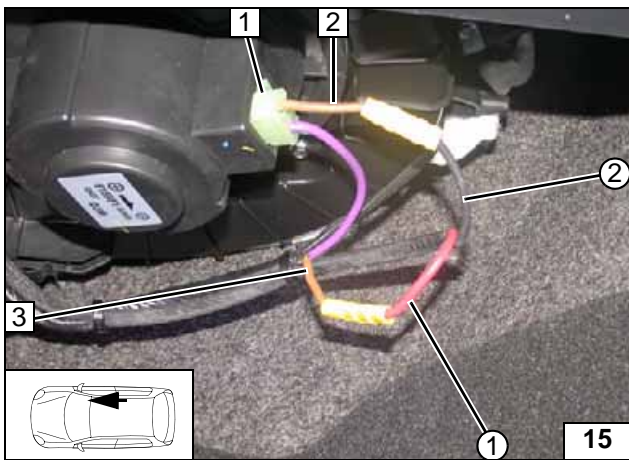

Connection to 2-pin connector **1** from fan motor. Produce connections as shown in wiring diagram.



- 2 Brown (br) wire of 2-pin connector, Pin 2
- 3 Brown (br) wire of fuse F52DA
- ① Red (rt) wire from K1/87a
- ② Black (sw) wire of K1/30

**Connec-
tion of fan
motor MB**



Digital Timer

Figure shows model year 2011.

- 1 Digital timer



Mounting digital timer

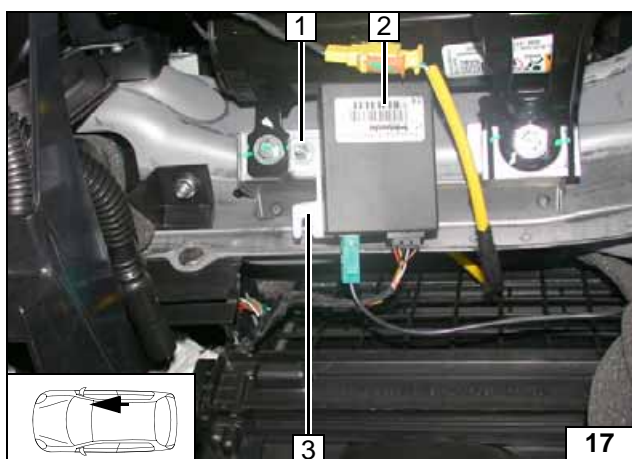

Remote Option (Telestart)

- 1 M5x20 bolt, washer, flanged nut, existing hole
- 2 Receiver
- 3 Bracket



Installing receiver

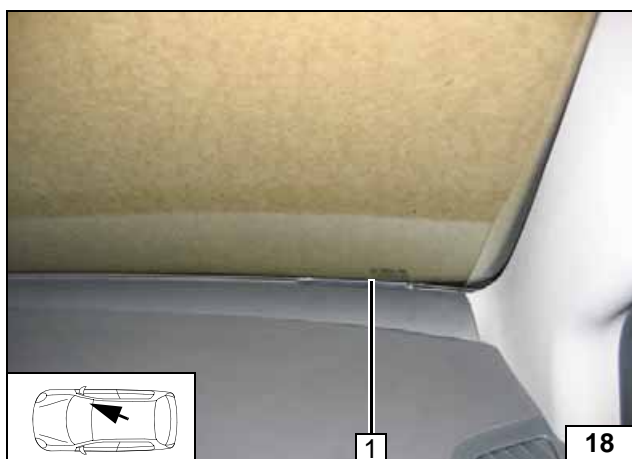

- 1 Antenna

Installing antenna

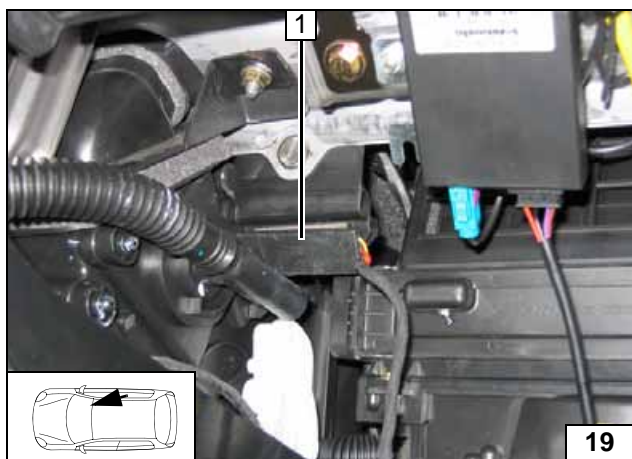

Temperature sensor T100 HTM

Fasten temperature sensor 1 with adhesive tape.



Installing temperature sensor

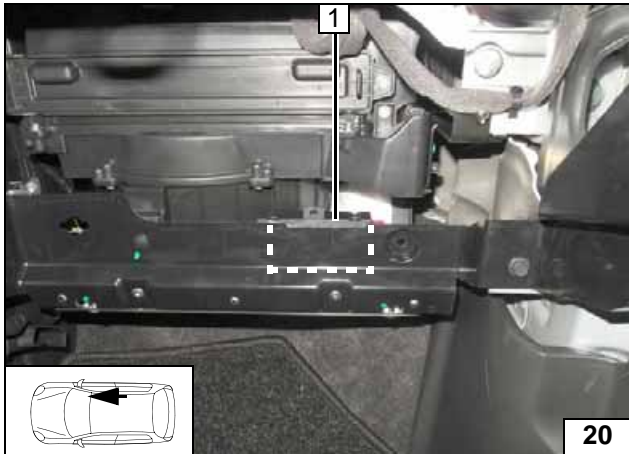

Remote Option (Thermo Call TC3)

Fasten receiver 1 with double-sided adhesive tape.

Installing receiver

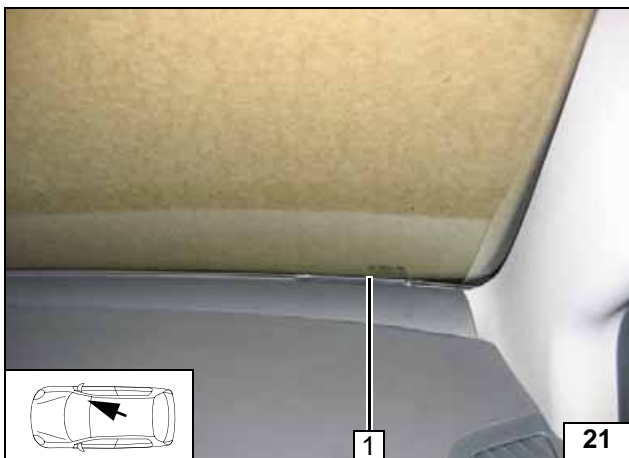

1 Antenna

Installing antenna

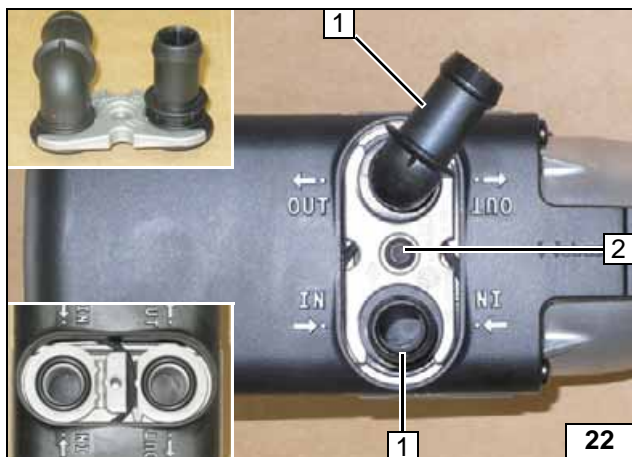

Preparing Heater

- 1 Water connection piece, sealing ring [2x each]
- 2 5x15 self-tapping bolt, retaining plate of water connection piece



Installing water connection pieces

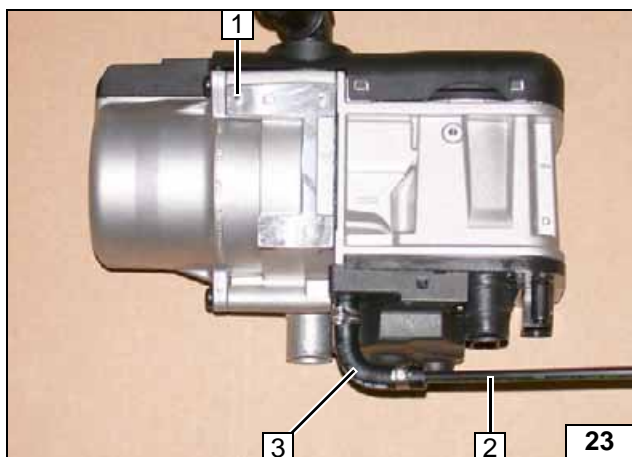

Tap threads with 5x13 self-tapping bolt at position 1.

- 2 Fuel line
- 3 90° moulded hose, 10 mm dia. clamp [2x]



Mounting fuel line

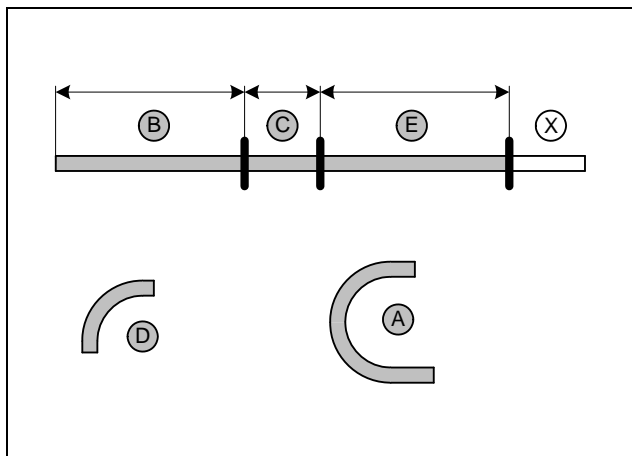

Discard section X.

Hose A = 180°, 20mm dia. moulded hose
Hose D = 90°, 18mm dia. moulded hose

	SG	AG
B =	600	600
C =	120	120
E =	540	610



Cutting hoses to length

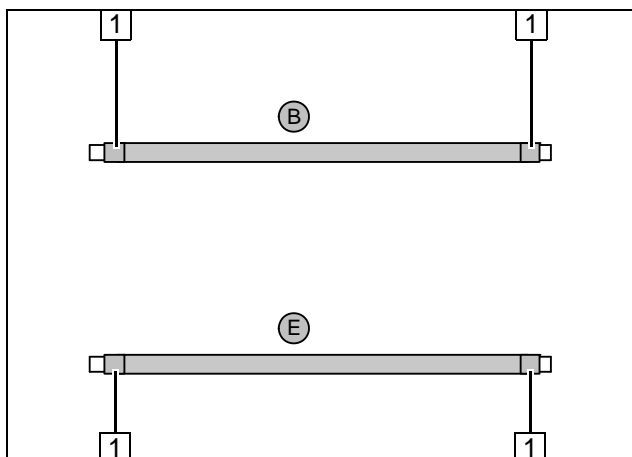

Slide braided protection hoses onto hoses B and E and cut to length.
Cut heat shrink plastic tubing to length.

- 1 50 mm long heat shrink plastic tubing [4x]



Preparing hoses

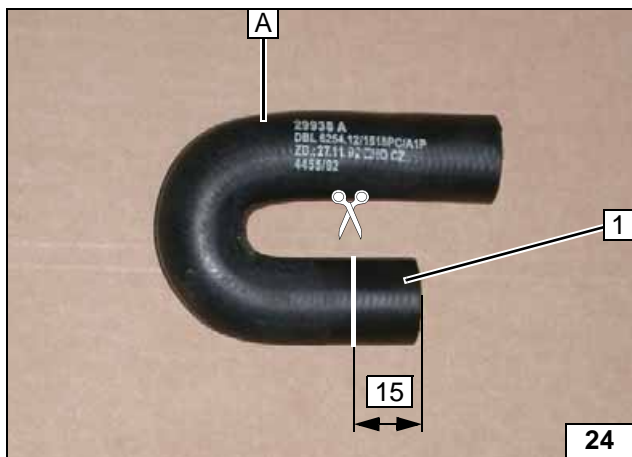

1 Discard section

Shortening hose A

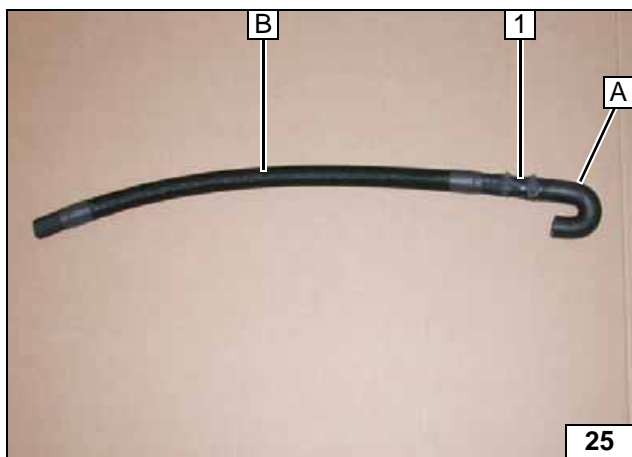

1 18x20mm dia. connecting pipe, 25mm dia. spring clip, 27mm dia. spring clip

Connect-ing hoses A and B

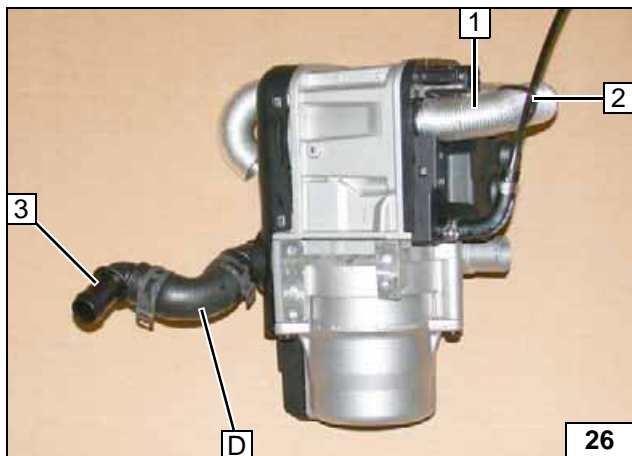

All spring clips = 25mm dia.

- 1 Combustion air pipe
- 2 Cable tie
- 3 90° connecting pipe 90°, 18x18mm dia.

Premount-ing heater

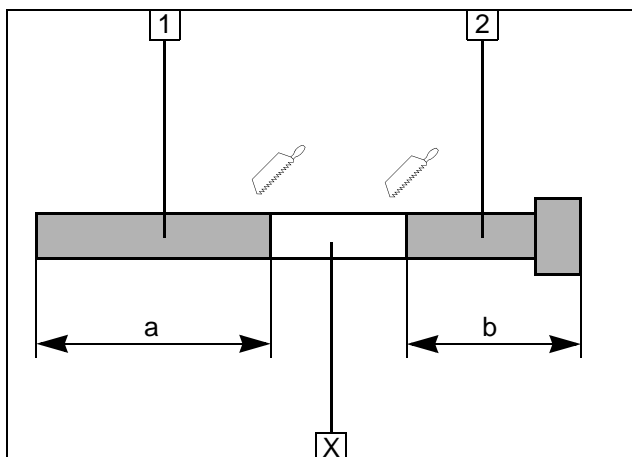

Discard section X.

- 1 Combustion air pipe
a = 400
- 2 Exhaust end section
b = 220

Preparing exhaust pipe

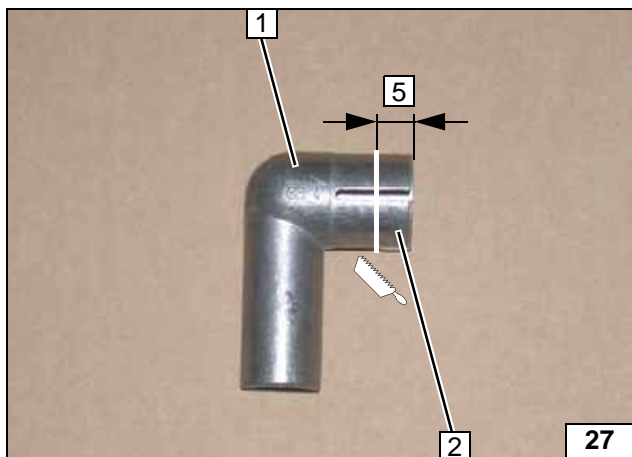

- 1 Exhaust elbow
- 2 Discard section

Cutting ex-
haust el-
bow to
length

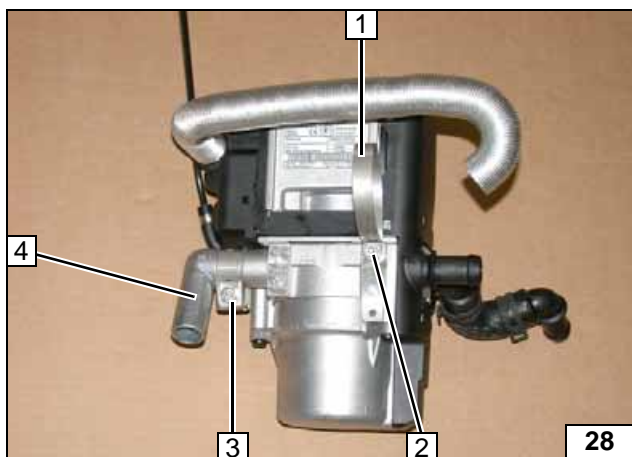

- 1 51mm dia. clamp
- 2 Mount 5x13 self-tapping bolt loosely
- 3 Hose clamp
- 4 Exhaust elbow

Premount-
ing heater

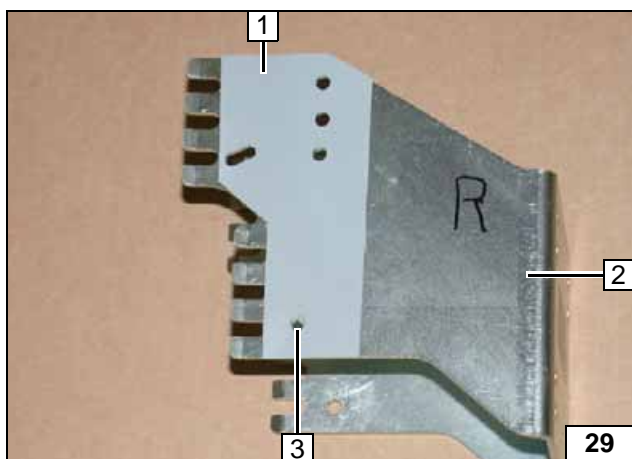

Preparing Bracket

Cut out template 1 and place on bracket 2 (right side) as shown.

- 3 Copy hole pattern, 5.5mm dia. hole

Hole in
bracket

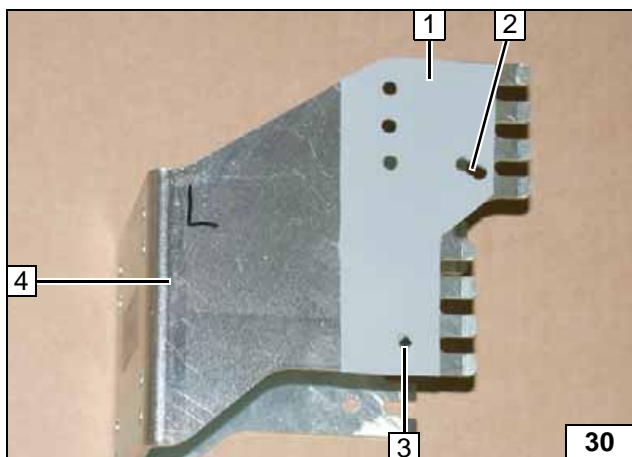

Place template 1 on bracket 4 (left side) as shown.

- 2 Copy oblong hole pattern, 5.5x11mm dia. hole
- 3 Copy hole pattern, 5.5mm dia. hole

Hole in
bracket



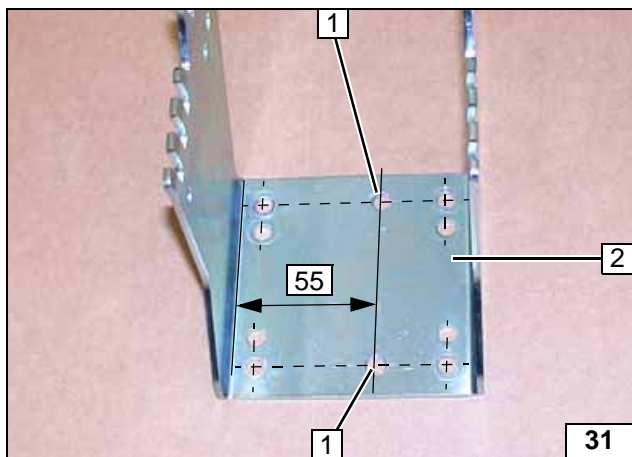

- 1 7 mm dia. hole [2x]
- 2 Bracket

Hole in bracket

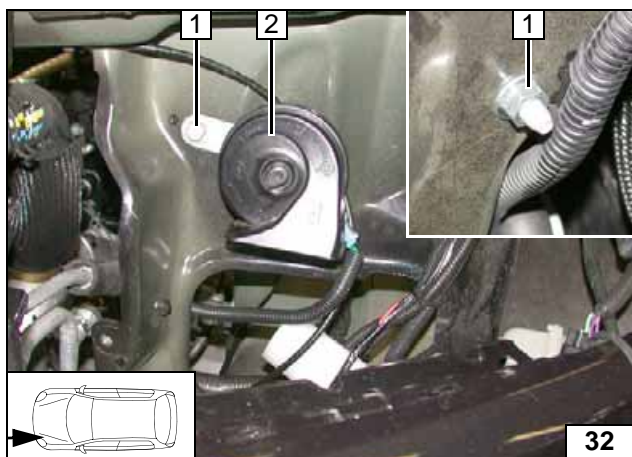

Preparing Installation Location

Chevrolet Captiva

- 1 Original vehicle bolt, horn bracket, existing hole, flanged nut
- 2 Horn

Moving horn

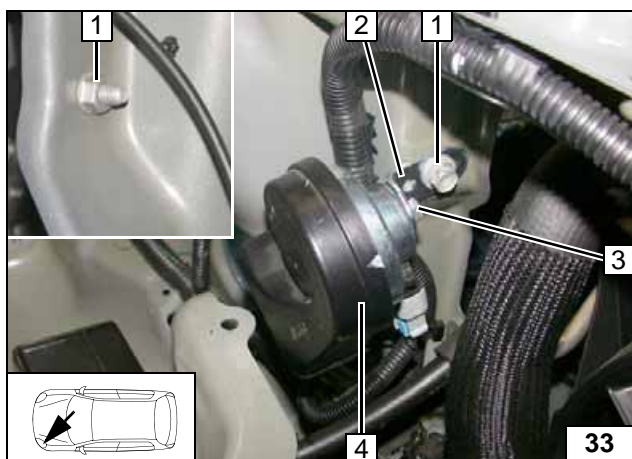

Opel Antara

- 1 Original vehicle bolt, existing hole, flanged nut
- 2 Angle bracket
- 3 Original vehicle bolt
- 4 Horn

Moving horn

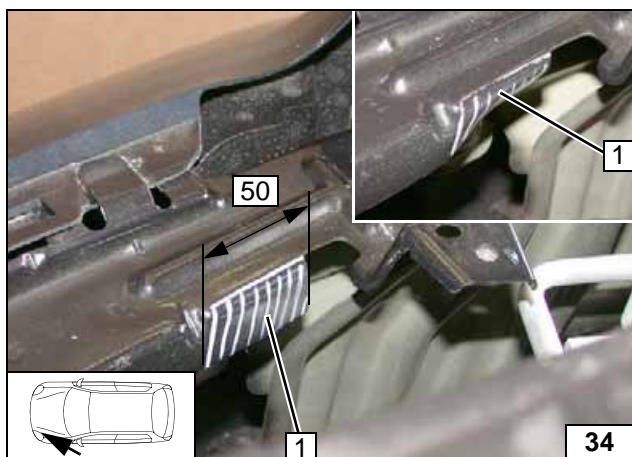

Align sheet edge 1 as shown.



Aligning edge

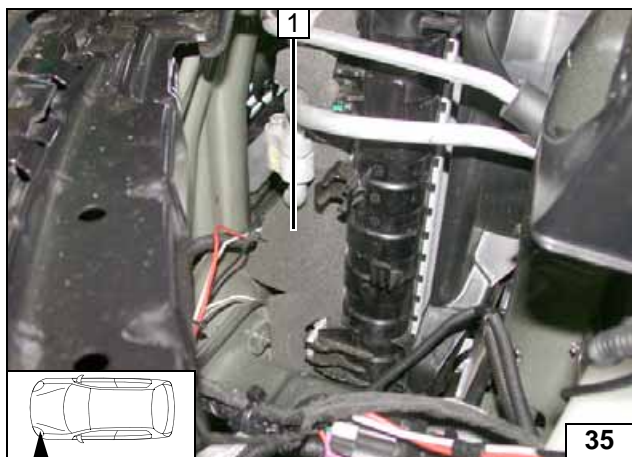

All vehicles

Cut foam 1 and fold towards the centre



Preparing installation location

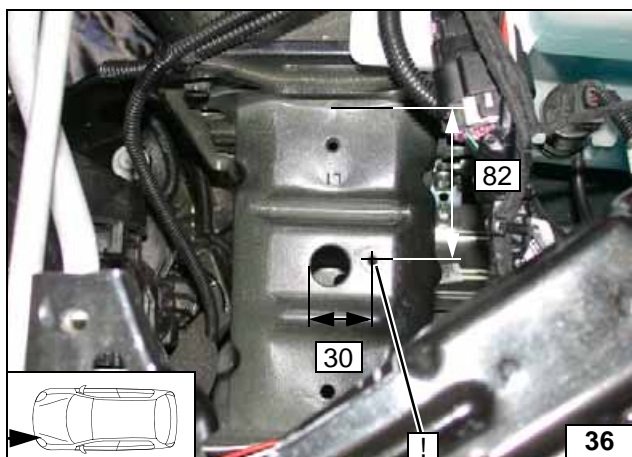

1 9.1mm dia. hole; rivet nut

Inserting rivet nut

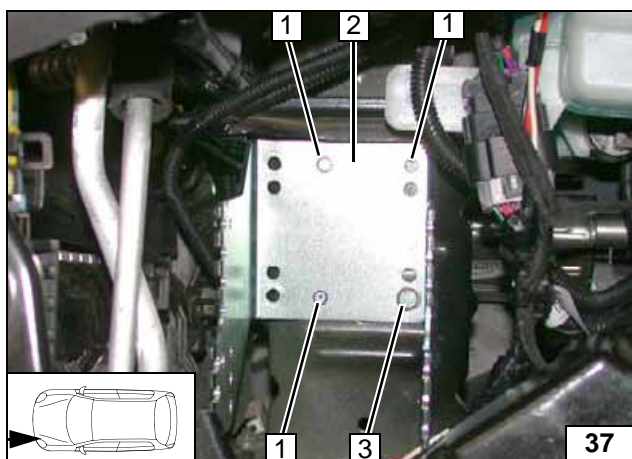

Mount bracket 2 loosely and align.

- 1 Copy hole pattern [3x]
- 3 M6x20 bolt



Copying hole pattern

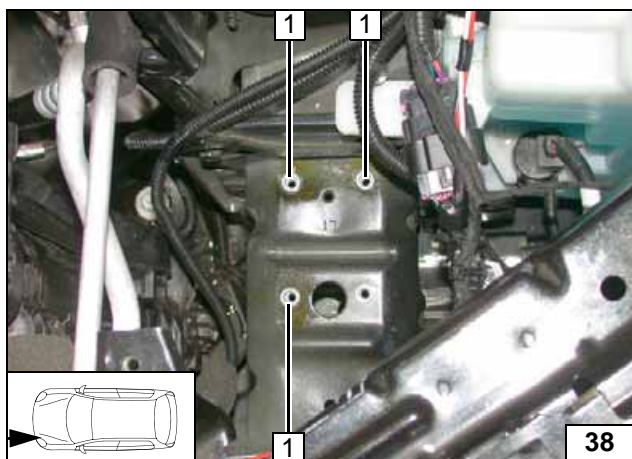

1 9.1mm dia. hole; rivet nut [3x each]

Inserting rivet nut

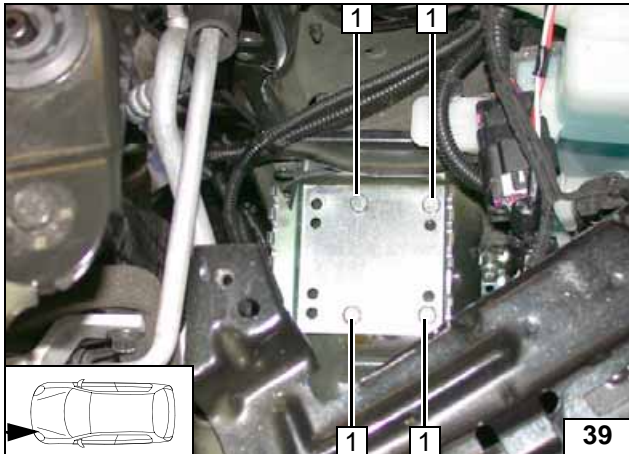

- 1 M6x20 bolt, spring lockwasher [4x each]

Installing bracket

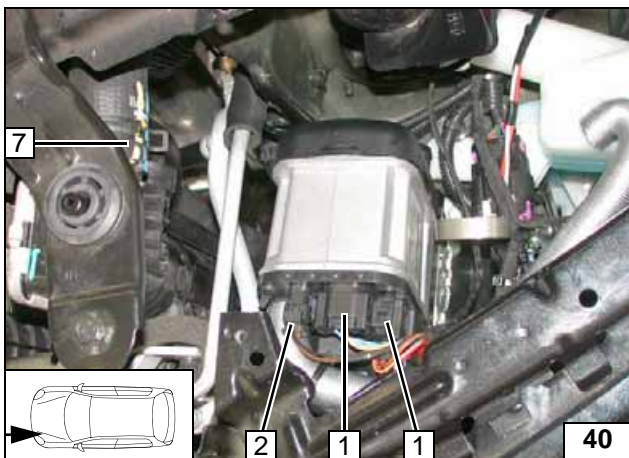

Installing Heater

Install heater in bracket as shown in the following two figures.

- 1 Wiring harness of heater [2x]
- 2 Wiring harness of circulating pump

Mounting wiring harnesses

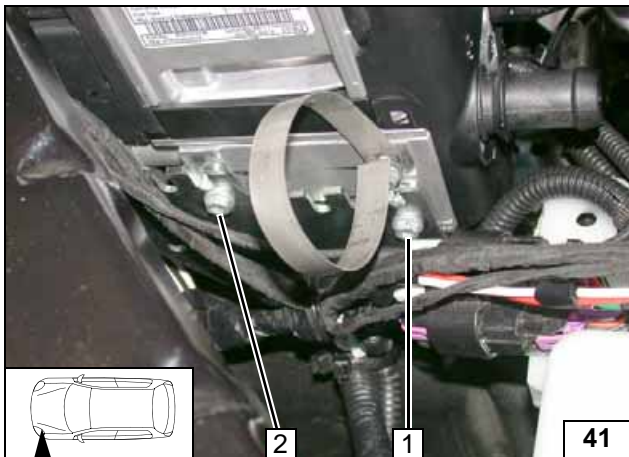

Align heater. Ensure sufficient distance from neighbouring components, correct if necessary.

- 1 5x13 self-tapping bolt; pre-drilled hole (left side of bracket)
- 2 5x13 self-tapping bolt; pre-drilled oblong hole (left side of bracket)

Installing heater

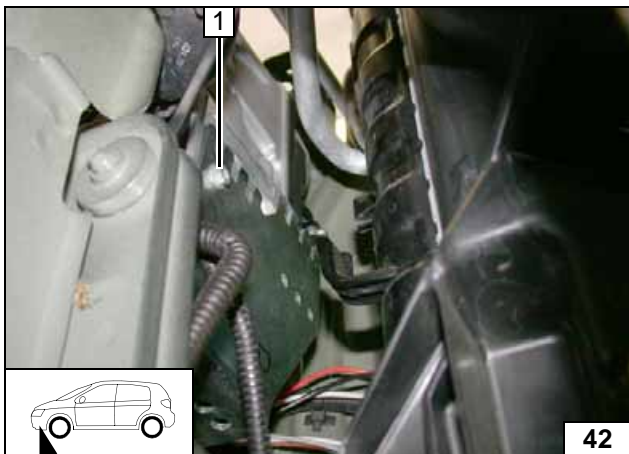

- 1 5x13 self-tapping bolt

Installing heater



Fuel

CAUTION!

Open the vehicle's fuel tank cap, ventilate the tank and then re-close the tank lock.

Catch any fuel running off in an appropriate container.

Install fuel line and metering pump wiring harness so that they are protected against stone impact. Unless specified otherwise, always fasten using cable ties.

Mount the fuel line and wiring harness with rub protection on sharp edges.

WARNING!

The fuel line and wiring harness are routed to the metering pump as shown in the wiring harness routing diagram.

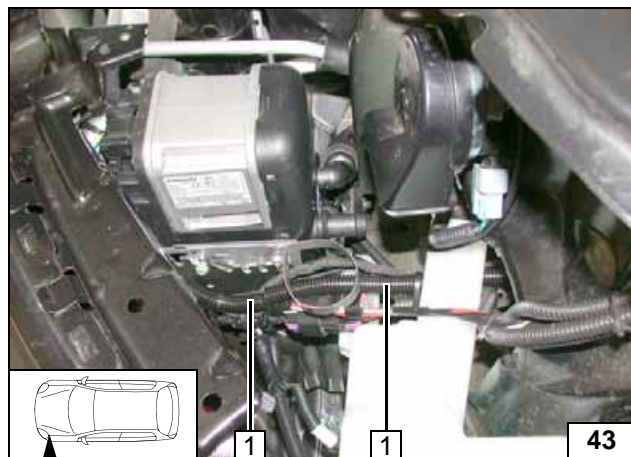

Route fuel line and wiring harness of metering pump in 10mm dia. corrugated tube 1 to firewall.

Installing lines

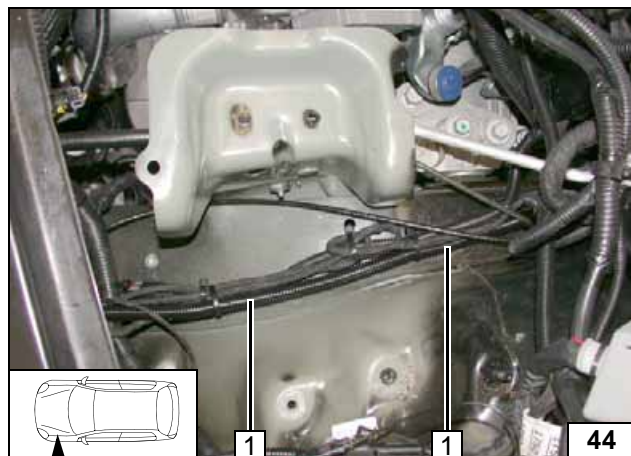

Route fuel line and wiring harness of metering pump in 10mm dia. corrugated tube 1 to firewall.

Installing lines

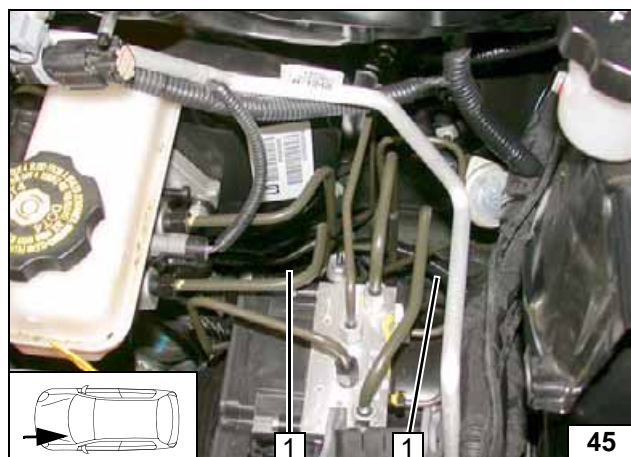

Route fuel line and wiring harness of metering pump in 10mm dia. corrugated tube 1 along original vehicle lines to underbody.



Installing lines

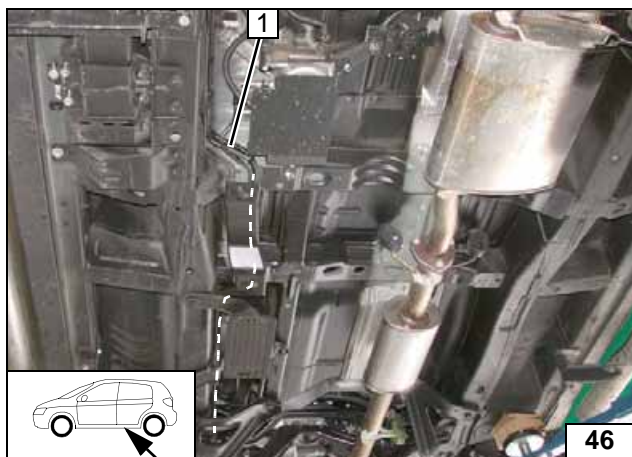

Route fuel line and wiring harness of metering pump in 10mm dia. corrugated tube 1 along original vehicle lines to installation location of metering pump.

Installing lines

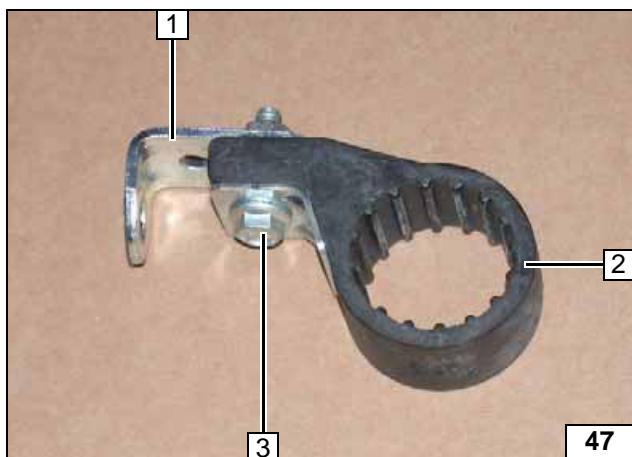

- 1 Angle bracket
- 2 Mounting of metering pump
- 3 M6x25 bolt, support angle bracket, flanged nut

Preinstalling mounting of metering pump

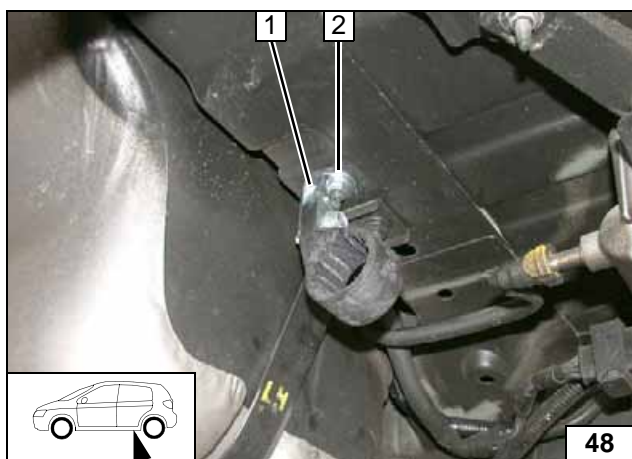

- 1 Angle bracket
- 2 Original vehicle stud bolt, M6 flanged nut

Installing mounting of metering pump

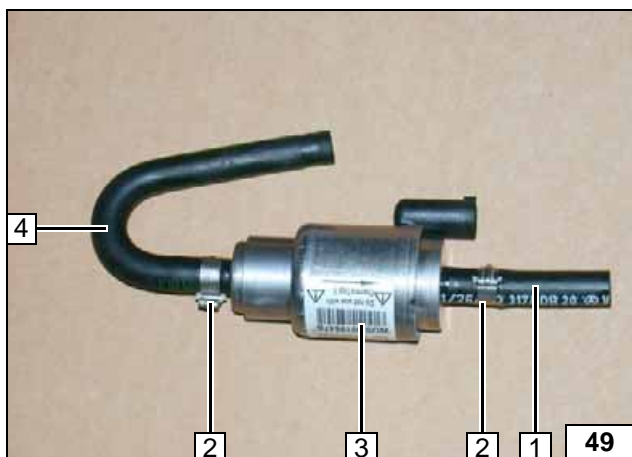

- 1 Hose section
- 2 10mm dia. clamp [2x]
- 3 Metering pump
- 4 180° moulded hose

Premounting metering pump



Mounting and connecting metering pump



Fuel extraction



Mounting fuel standpipe



Connecting fuel line

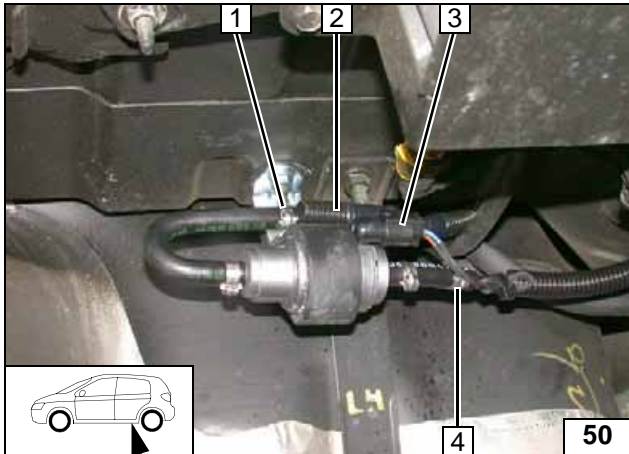

Check the position of the components; adjust if necessary. Check that they have freedom of movement.

- 1 10mm dia. clamp
- 2 Fuel line of fuel standpipe in 10mm dia., 400mm long corrugated tube
- 3 Wiring harness of metering pump, connector mounted
- 4 Fuel line of heater, 10mm dia. clamp

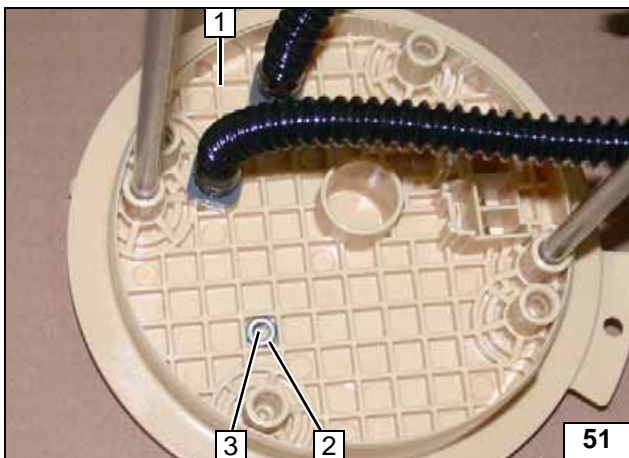

Remove and dismount fuel-tank sending unit 1 according to manufacturer's instructions.

- 2 M5 nut
- 3 Copy hole pattern, 6mm dia. hole

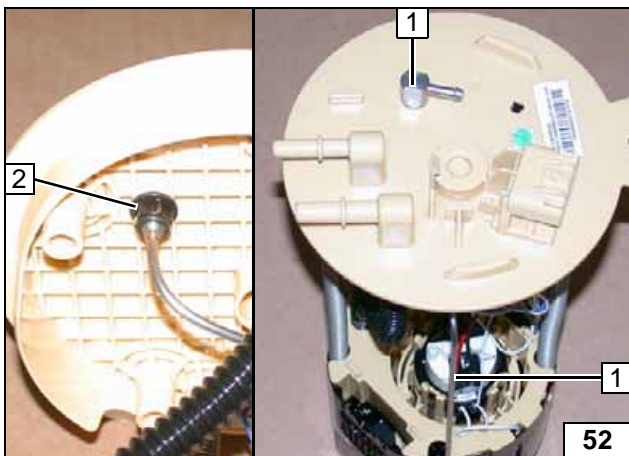

Shape fuel standpipe 1 according to template, and cut to length.

- 2 Flanged nut of fuel standpipe

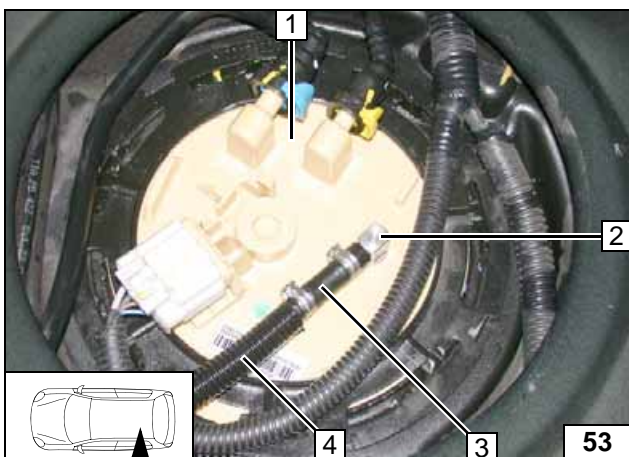

Install fuel-tank sending unit 1 according to manufacturer's instructions. Check the position of the components; adjust if necessary. Check that they have freedom of movement.

- 2 Fuel standpipe
- 3 Hose section, 10mm dia.clamp [2x]
- 4 Fuel line in 10mm dia. corrugated tube







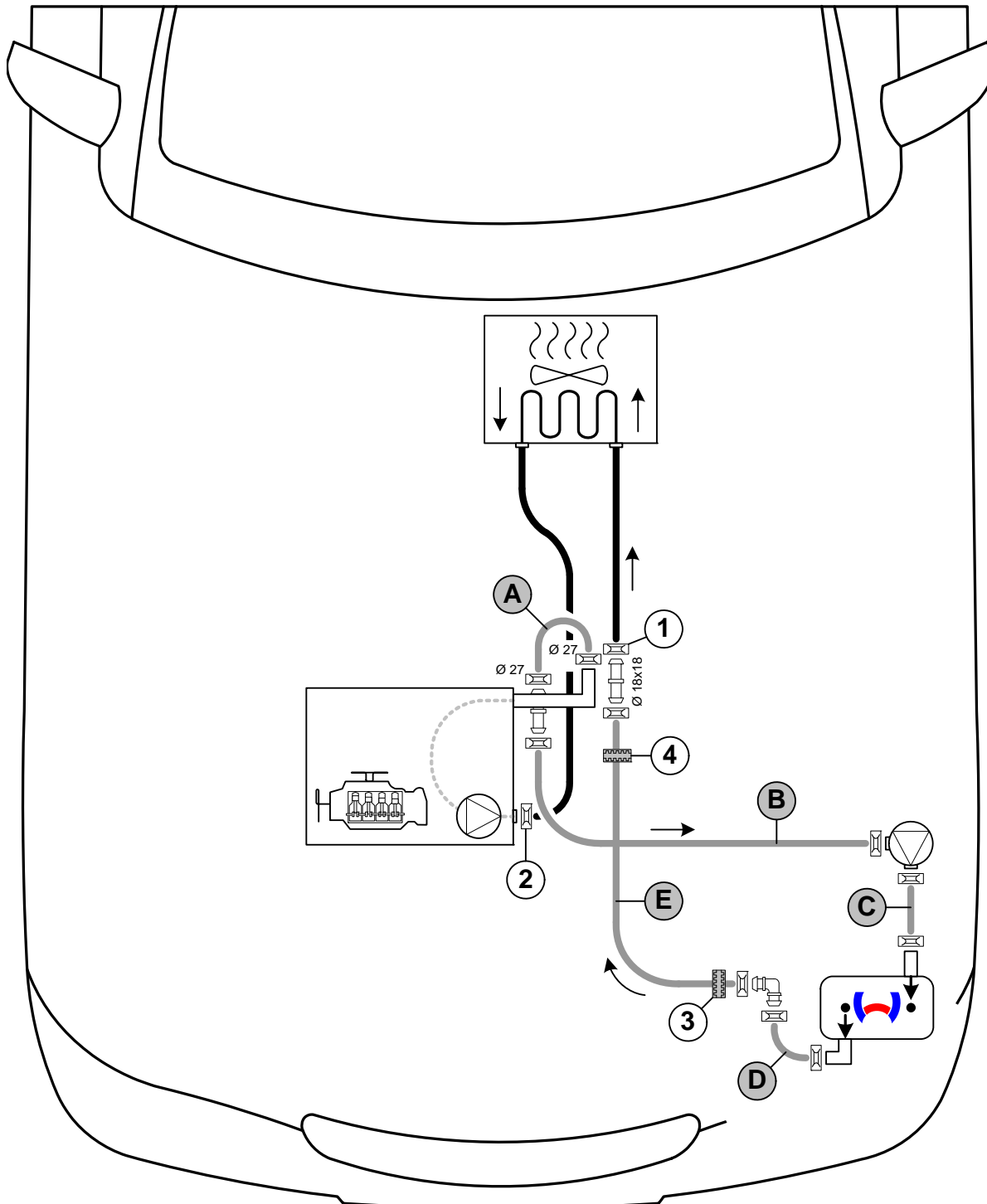

Coolant Circuit

WARNING!

Any coolant running off should be collected in an appropriate container. Install coolant hoses kink-free. Unless specified otherwise, always fasten using cable ties. Position clamps so that other hoses cannot be damaged. When installing the hoses, the heater must be filled with coolant. The connection should be "inline" based on the following diagram:



Hose routing diagram

All non-designated spring clips  = 25mm dia. **1** = Original vehicle spring clip .
2 = Spring clip  = 27mm dia. (only for manual transmission). **3** = Black (sw) rubber isolator .
4 = Black (sw) rubber isolator  (only for manual transmission).
 Connecting pipe  = 18x18mm dia. Not designated connecting pipe  = 18x20mm dia.



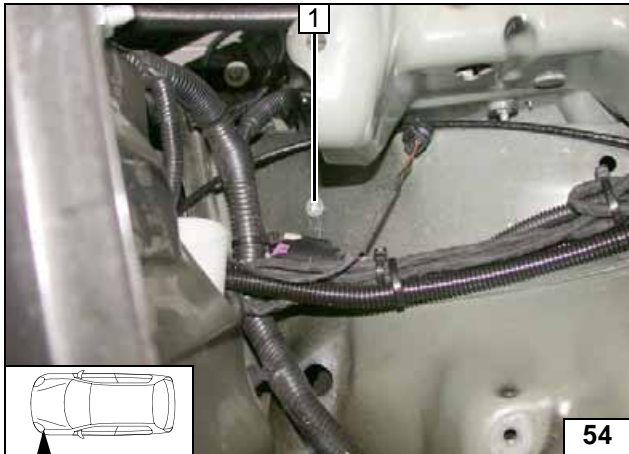

All vehicles

- 1 Drill out 9.1 mm dia. hole; rivet nut

**Inserting
rivet nut**

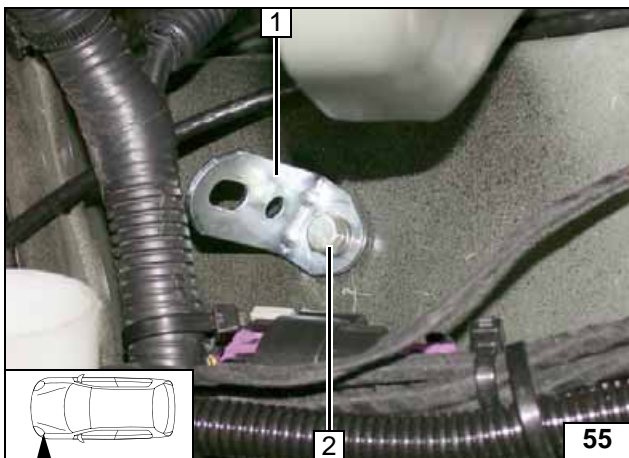

- 1 Angle bracket
- 2 M6x20 bolt, spring lockwasher

**Installing
angle
bracket**

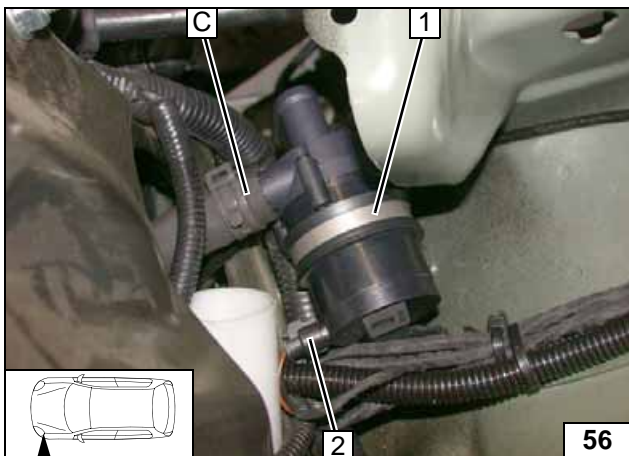

- 1 48mm dia. rubber-coated p-clamp, M6x20 bolt, flanged nut on angle bracket
- 2 Wiring harness of circulating pump mounted

**Installing
circulating
pump**

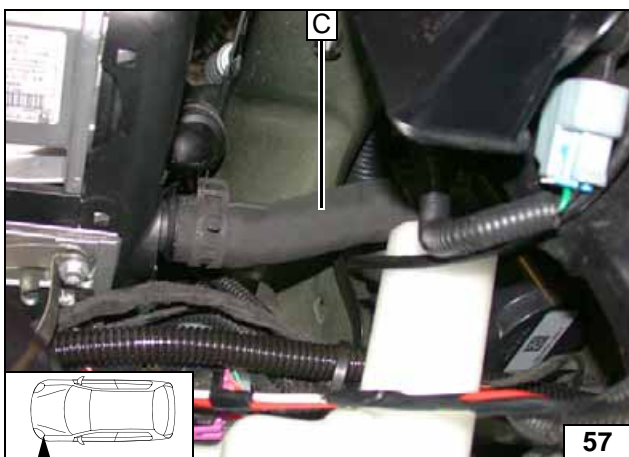

**Connect-
ing heater
inlet**

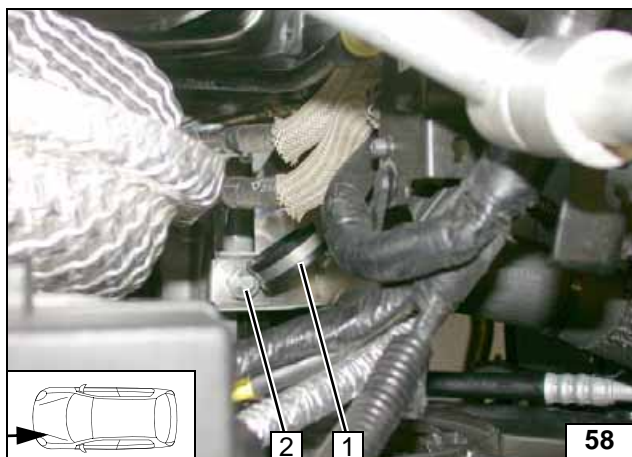

Remove bolt at position 2 and discard.

- 1 Rubber-coated p-clamp 38mm dia.
- 2 Mount M6x35 bolt, 20mm shim loosely



Premounting rubber-coated p-clamp

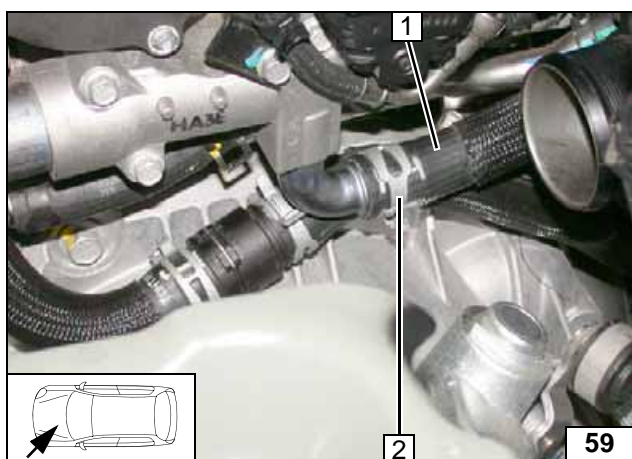
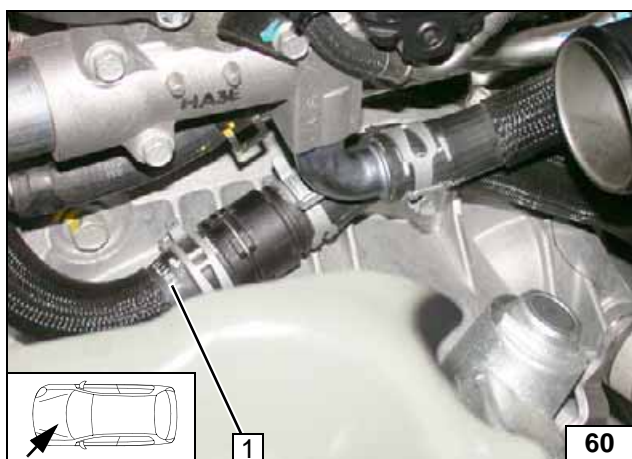

Figure shows manual transmission. Pull hose of engine outlet / heat exchanger inlet 1 off connection piece of engine outlet. Spring clip 2 will be reinserted.



Cutting point



Manual transmission

Remove hose of heat exchanger outlet/engine inlet 1.



Cutting point

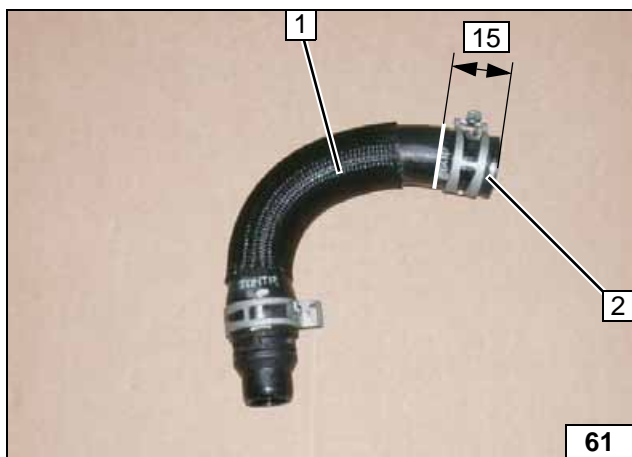

- 1 Hose of heat exchanger outlet/engine inlet
- 2 Discard section with spring clip (pasted)

Shortening hose

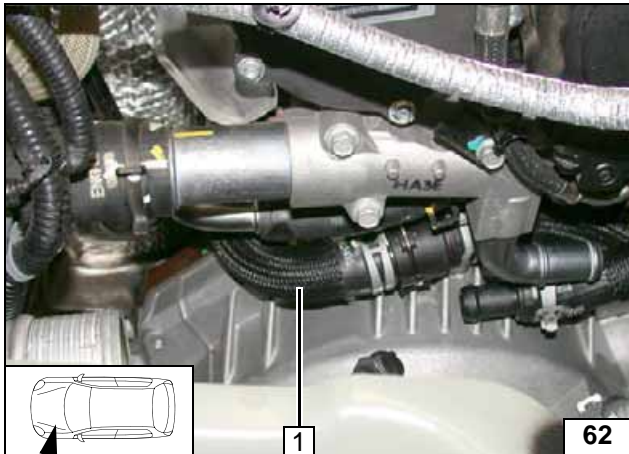

Hose of heat exchanger outlet/engine inlet **1** remounted. Use 27mm dia. spring clip on connection piece of engine inlet.



Mounting hose

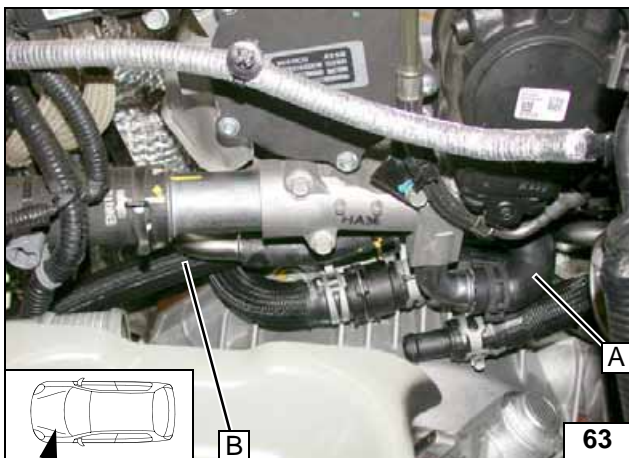

**Connect-
ing engine
outlet**

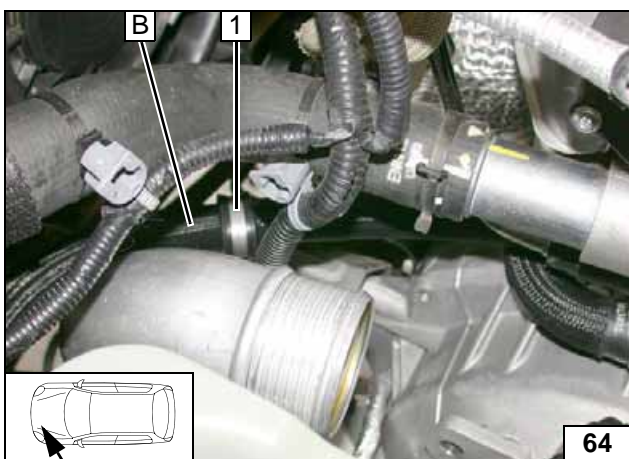

Route hose **B** through 38mm dia. rubber-coated p-clamp **1**.



**Routing in
engine
compartment**

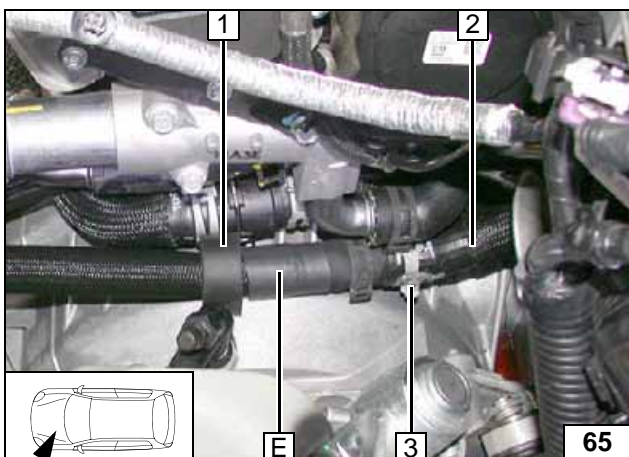

Slide black (sw) rubber isolator **1** on hose **E** and align as shown.

- 2** Hose on heat exchanger inlet
- 3** Original vehicle spring clip



**Connec-
tion of heat
exchanger
inlet**

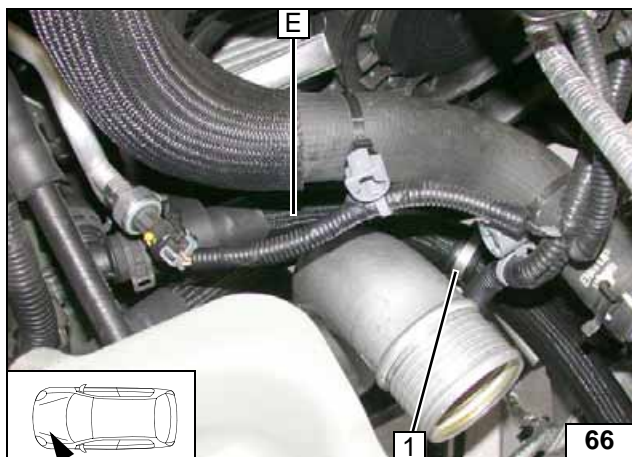

Route hose **E** through 38mm dia. rubber-coated p-clamp **1**.



Routing in engine compartment

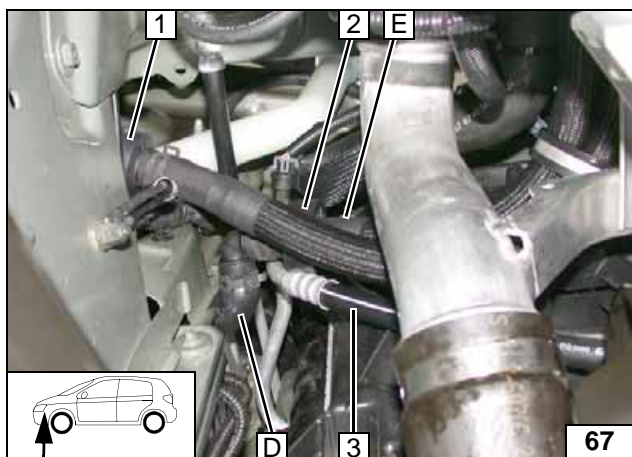

Slide black (sw) rubber isolator **2** on hose **E** and align with A/C line **3**.

1 Circulating pump



Connecting heater

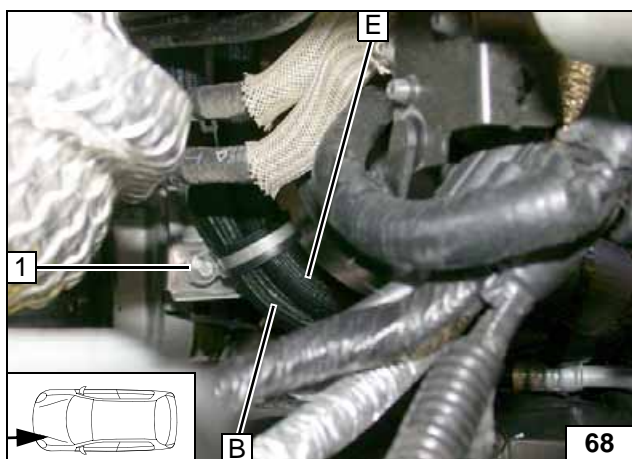

Ensure sufficient distance from neighbouring components, correct if necessary.

1 Tighten M6x35 bolt



Aligning hoses

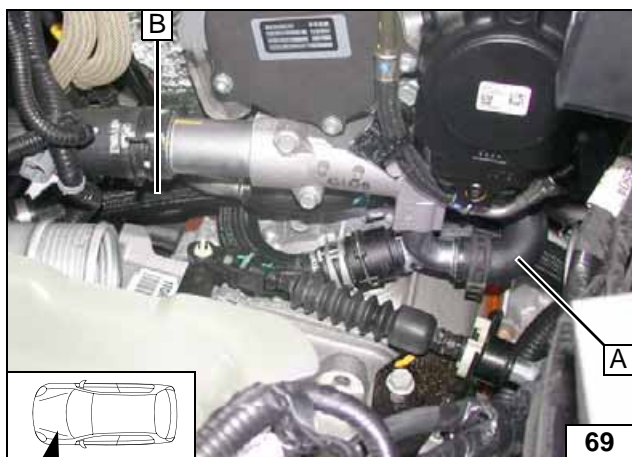

Automatic transmission

Connection of engine outlet

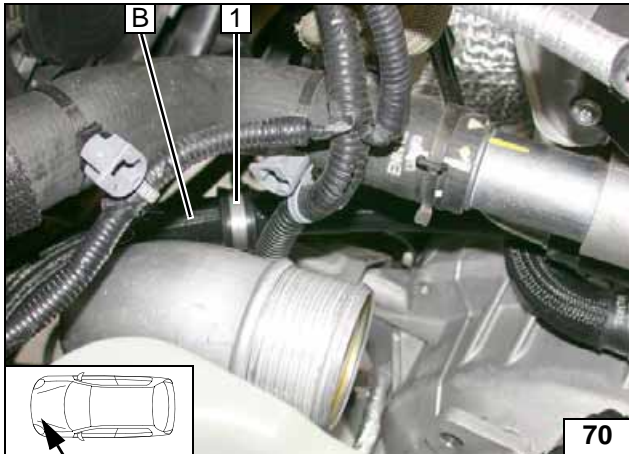

Route hose **B** through 38mm dia. rubber-coated p-clamp.



Routing in engine compartment

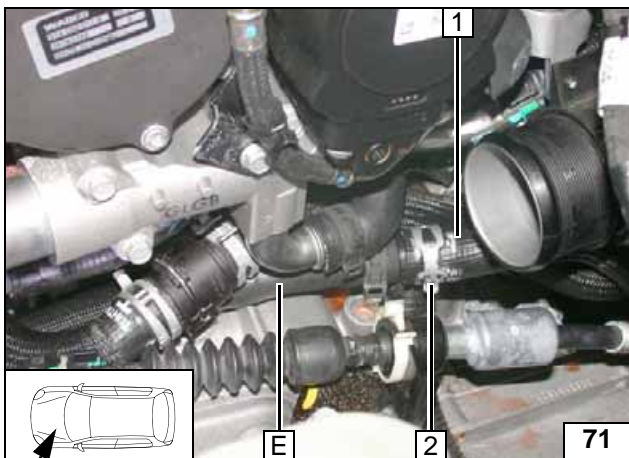

1 Hose on heat exchanger inlet
2 Original vehicle spring clip

Connection of heat exchanger inlet

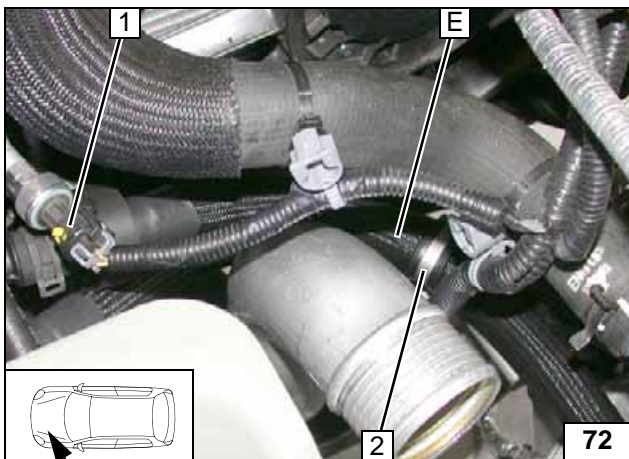

Route hose **E** through 38mm dia. rubber-coated p-clamp **2**. Remove original vehicle connector **1** to facilitate mounting.



Routing in engine compartment

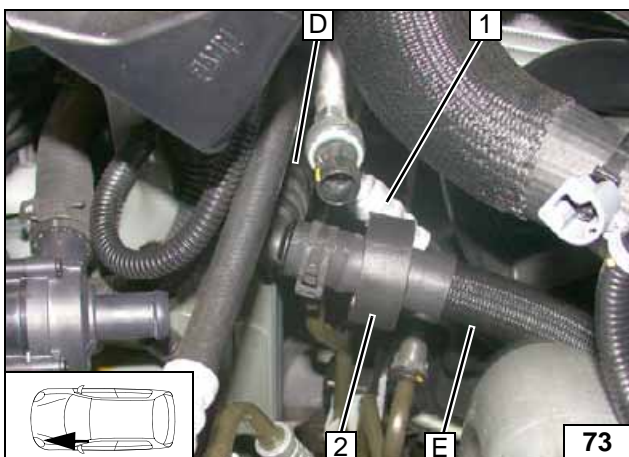

Slide black (sw) rubber isolator **2** onto hose **E** and align with hydraulic line **1**.



Connecting heater

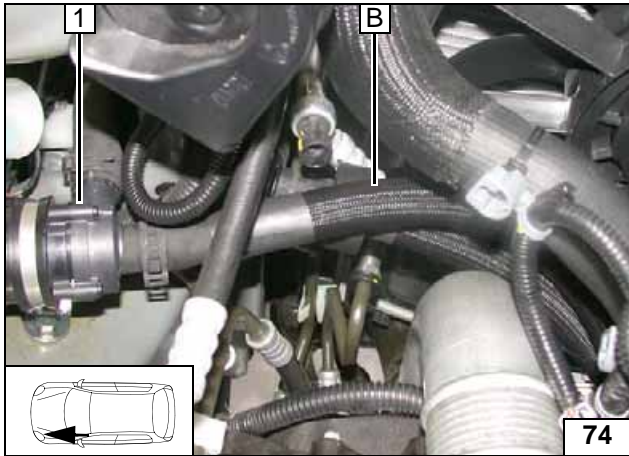

1 Circulating pump

Connect-
ing circu-
lating
pump



1 Original vehicle connector

Inserting
connector

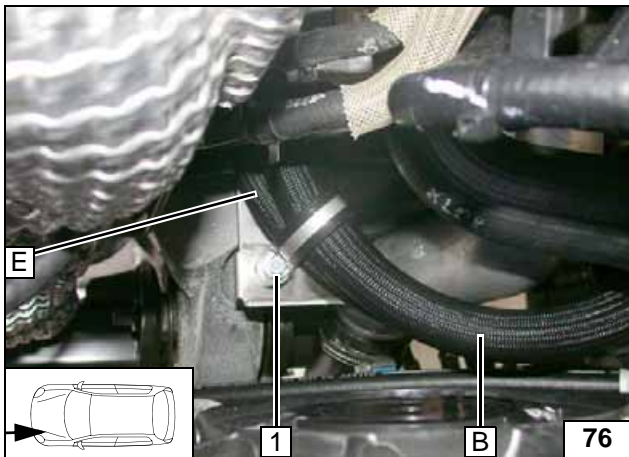

Ensure sufficient distance from neighbouring components, correct if necessary.

1 Tighten bolt



Aligning
hoses

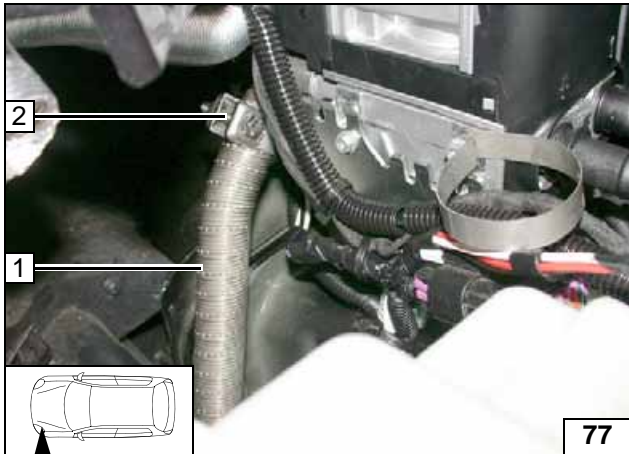
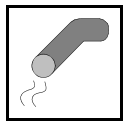

Exhaust Gas

- 1 Exhaust pipe on exhaust elbow
- 2 Hose clamp

Mounting exhaust pipe

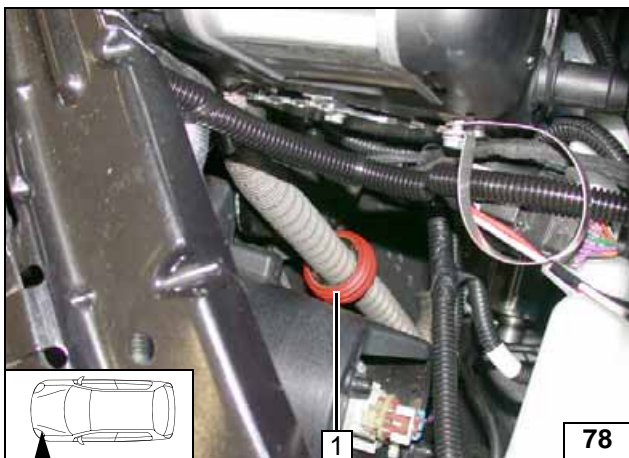

Slide on spacer bracket 1 and align as shown.



Routing exhaust pipe

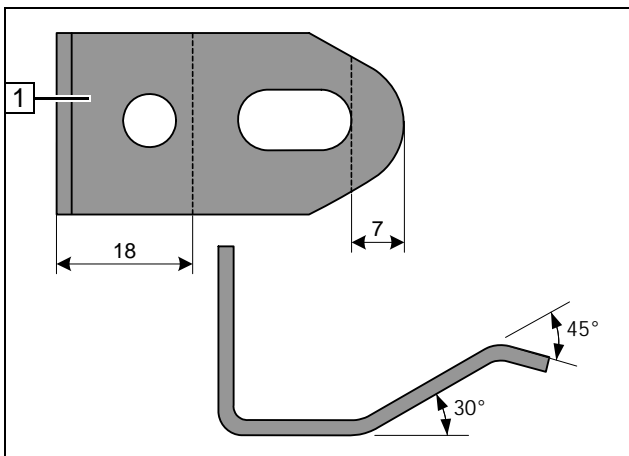

Drill out hole of angle bracket 1 in the short leg to 8.5mm dia.



Preparing angle bracket

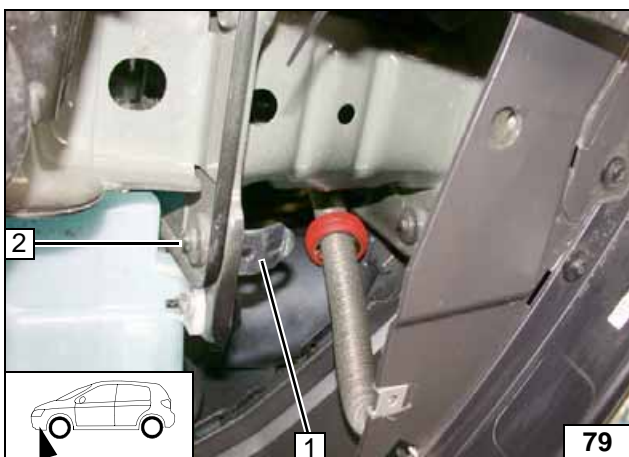

- 1 Angle bracket
- 2 Original vehicle bolt

Installing angle bracket

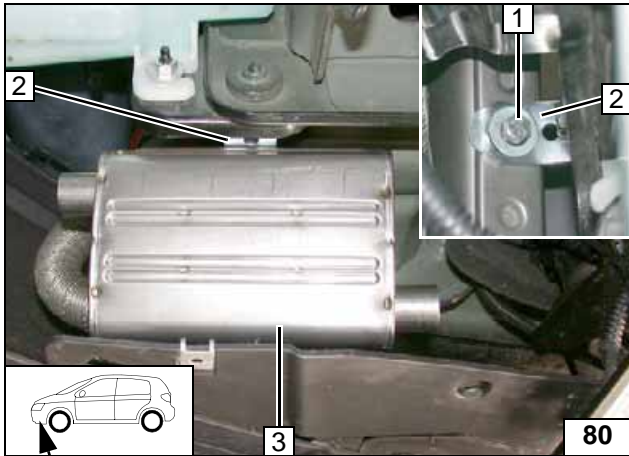
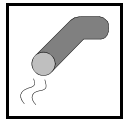

- 1 M6x16 bolt, spring lockwasher, large diameter washer
- 2 Angle bracket
- 3 Silencer

Installing silencer

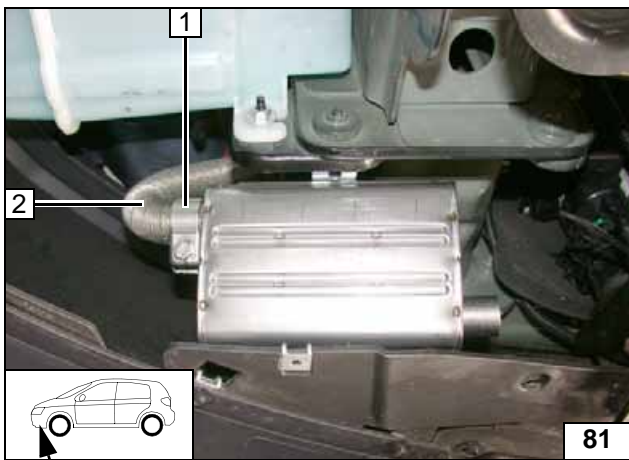

- 1 Hose clamp
- 2 Exhaust pipe

Mounting exhaust pipe

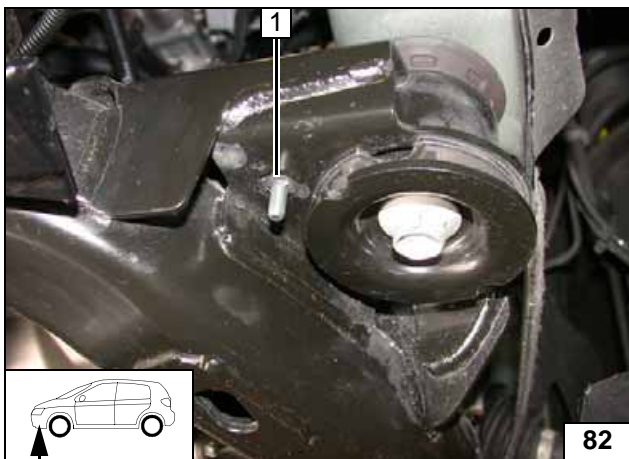

- 1 M6x20 bolt, large diameter washer, pin lock, existing hole

Inserting bolt

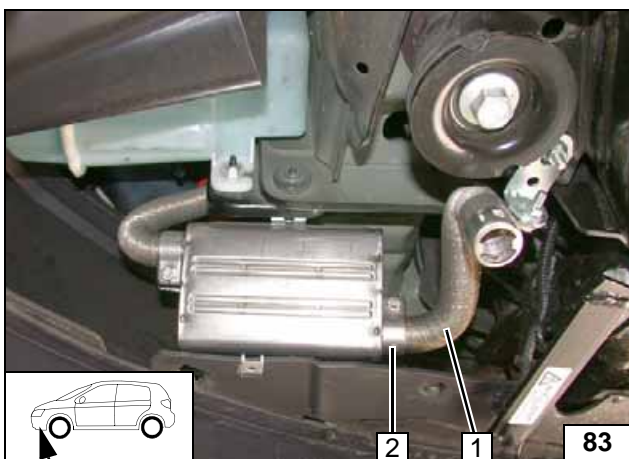

- 1 Exhaust end section
- 2 Hose clamp

Mounting exhaust end section

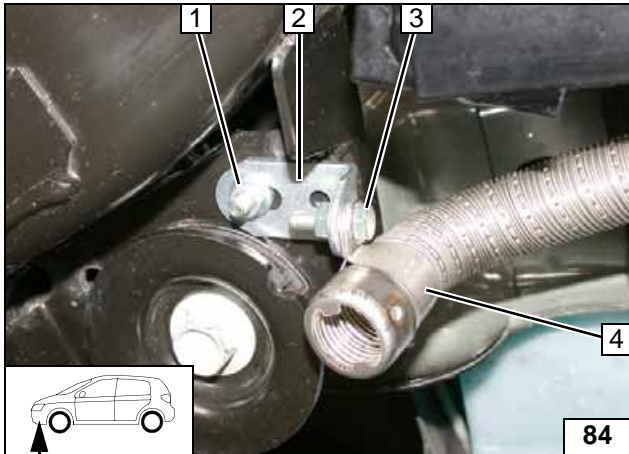
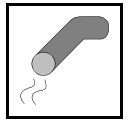

Ensure sufficient distance from neighbouring components, correct if necessary.



- 1 M6 flanged nut
- 2 Angle bracket
- 3 M6x20 bolt, flanged nut
- 4 P-clamp

Fastening exhaust end section

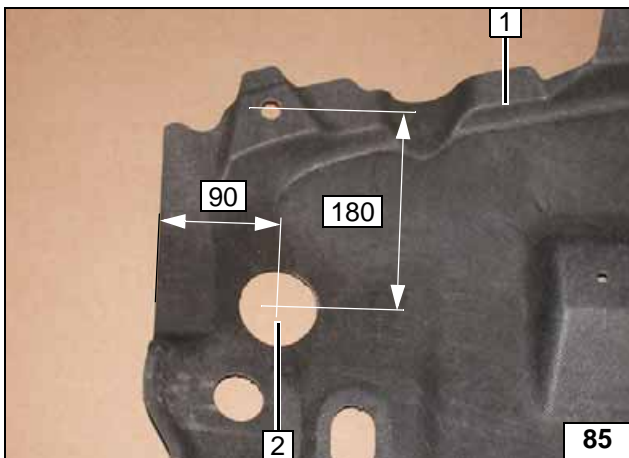

- 1 Underride protection
- 2 60mm dia. hole

Cutting underride protection

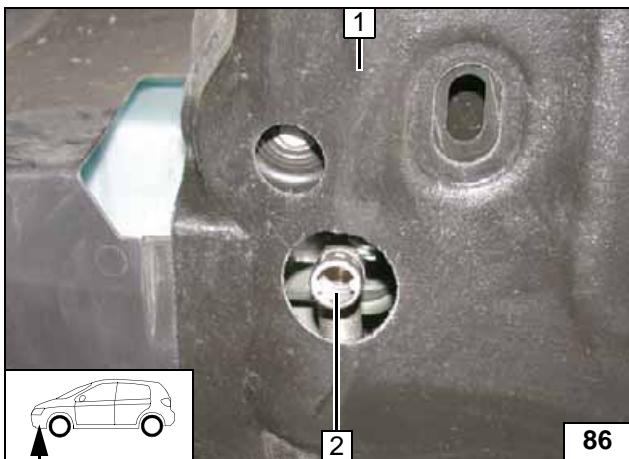

Align exhaust end section 2 in centre of hole.



- 1 Underride protection mounted

Fastening exhaust end section



Final Work

WARNING!

Mount removed parts in reverse order. Check all hoses, clamps and all electrical connections for firm seating. Insulate and tie back all loose lines.

Only use manufacturer-approved coolant. Spray the heater components with anti-corrosion wax (Tectyl 100K, Order No. 111329).

- Connect the battery.
- Fill and bleed the coolant circuit according to the vehicle manufacturer's specifications.
- Adjust digital timer, teach Telestart transmitter.
- Make settings on A/C control panel according to the "Operating Instructions for End Customer".
- Place signboard "Switch off parking heater before refuelling" in the area of the filler neck.
- For initial startup and function check, see installation instructions.
- Check power consumption of IPCU at fuse F4 in additional parking heating mode. The power consumption should lie between 3A and 4.5A, adjust voltage of IPCU if necessary.

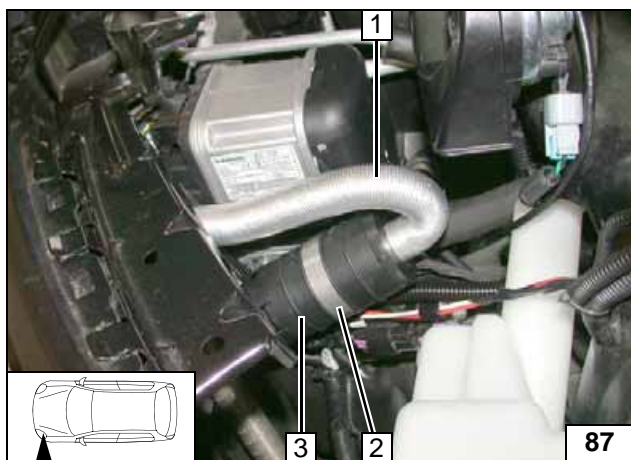

Fasten bolt of 51mm clamp 2.

- 1 Combustion air pipe
- 3 Silencer



**Installing
silencer**

Webasto Thermo & Comfort SE
Postfach 1410
82199 Gilching
Germany
Internet: www.webasto.com
Technical Extranet:
<http://dealers.webasto.com>

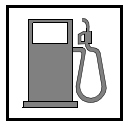

Fuel Standpipe Template

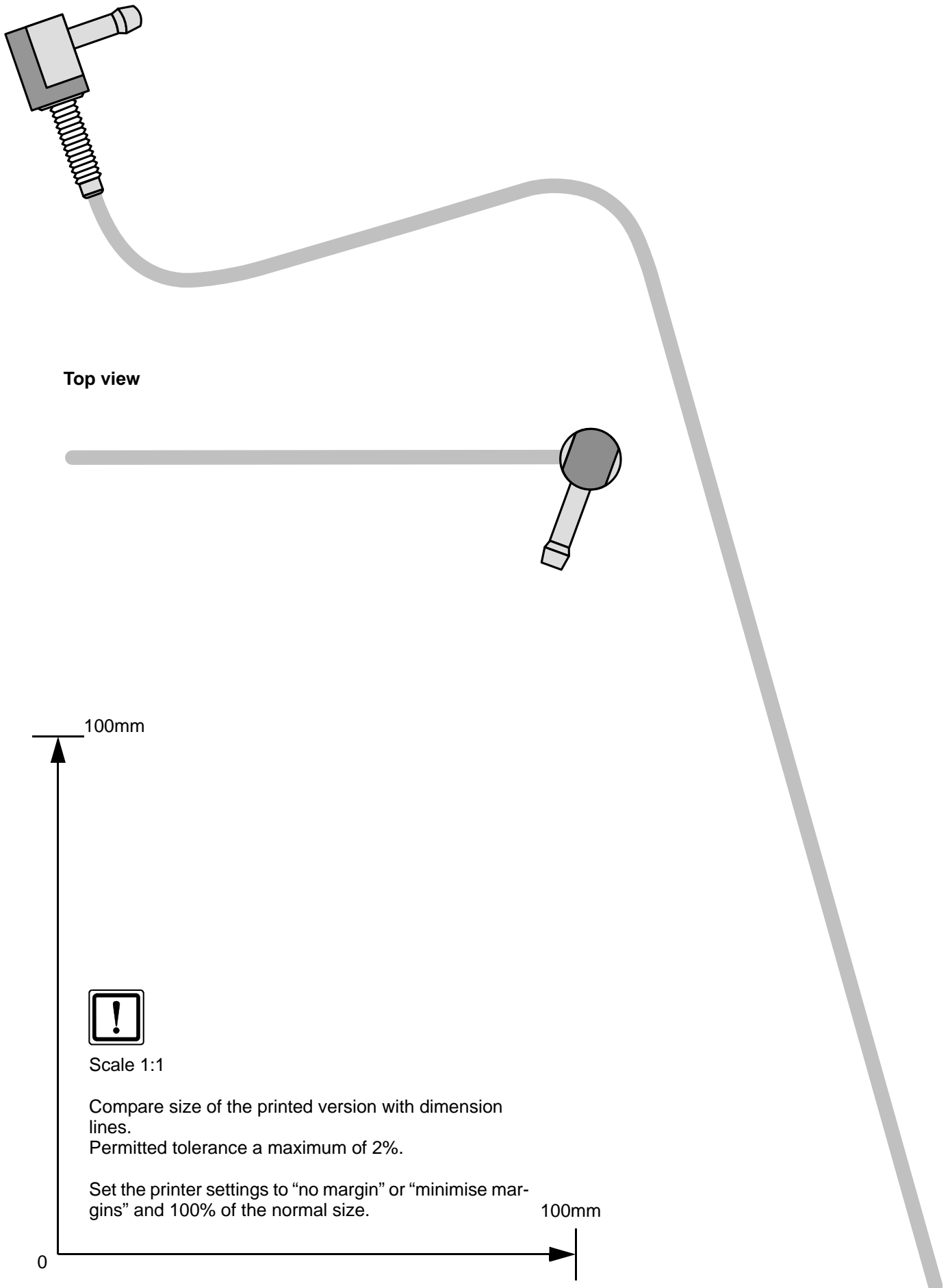

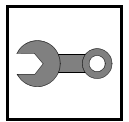

Template of bracket

for right and left side

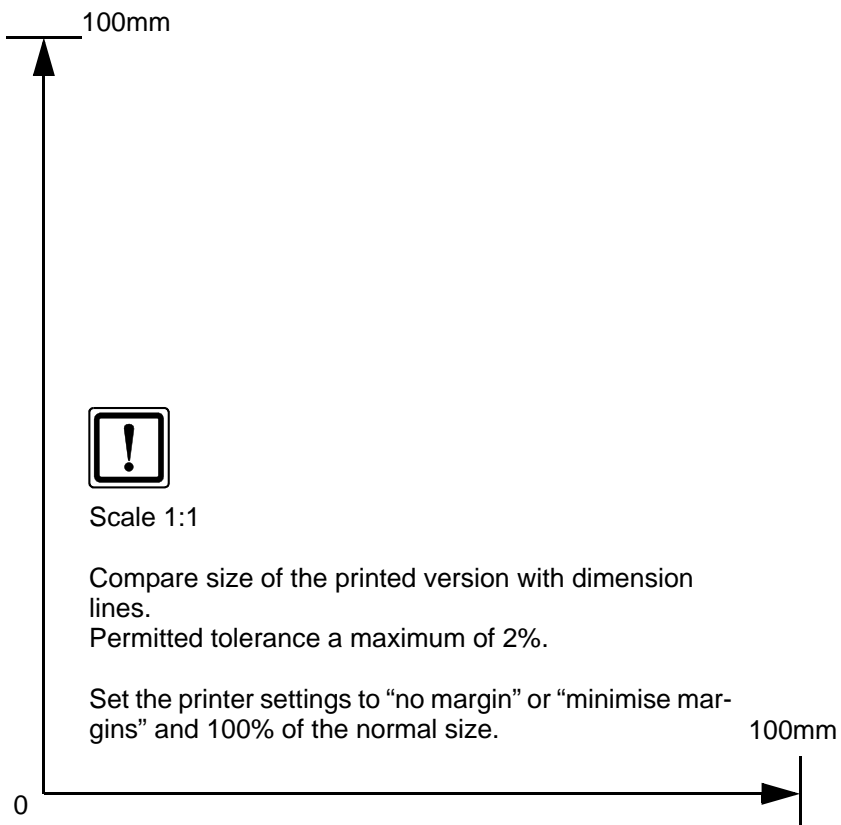
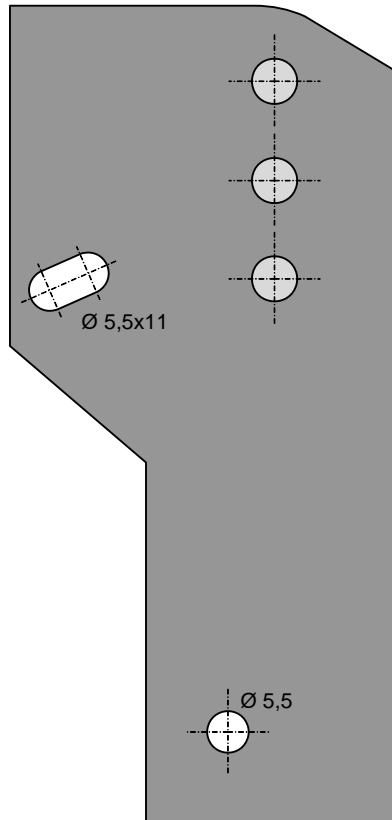

Operating Instructions for Chevrolet Captiva

Please remove page and add to the vehicle operating instructions.

Note:

We recommend matching the heating time to the driving time.
 Heating time = driving time

Example:

For a driving time of approx. 20 min. (in one direction), we recommend not exceeding a switch-on time of 20 min.

Passenger compartment monitoring, if installed, must be deactivated in addition to vehicle settings for the heating operation.

Instructions for the deactivation can be taken from the operating instructions of the vehicle.

Before parking the vehicle, make the following settings:



Up to MY 2012

- 1 Air outlet to windscreen
- 2 Set temperature to "HI"

A/C control panel



From MY 2013

- 1 Air outlet to windscreen
- 2 Set temperature to "HI" on both sides

A/C control panel

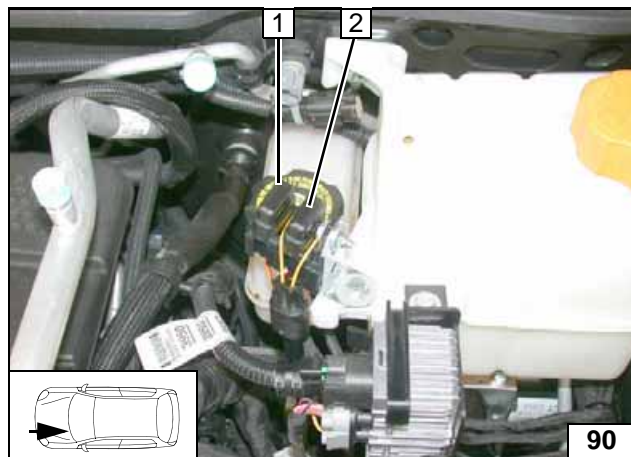

- 1 20A heater fuse F1
- 2 30A main fuse F2 of passenger compartment

Fuses of engine compartment



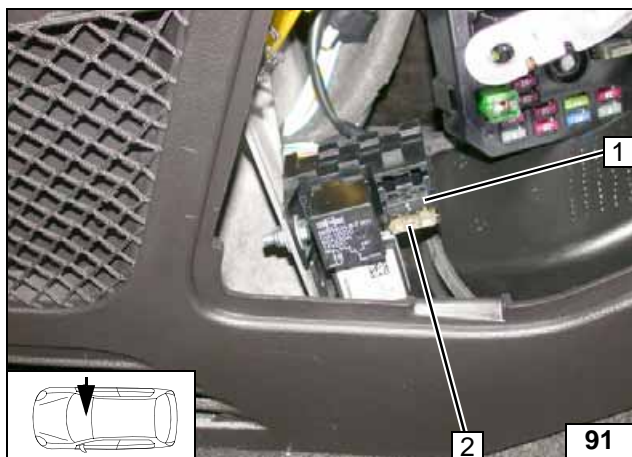

- 1 1A fuse F3 of heater control
- 2 25A fan fuse F4

Fuses of
passenger
compartment



Operating Instructions for Opel Antara

Please remove page and add to the vehicle operating instructions.

Note:

We recommend matching the heating time to the driving time.

Heating time = driving time

Example:

For a driving time of approx. 20 min. (in one direction), we recommend not exceeding a switch-on time of 20 min.

Passenger compartment monitoring, if installed, must be deactivated in addition to vehicle settings for the heating operation.

Instructions for the deactivation can be taken from the operating instructions of the vehicle.

Before parking the vehicle, make the following settings:



Up to MY 2012

- 1 Air outlet to windscreen
- 2 Set temperature to "HI"

A/C control panel



From MY 2013

- 1 Air outlet to windscreen
- 2 Set temperature to "HI" on both sides

A/C control panel

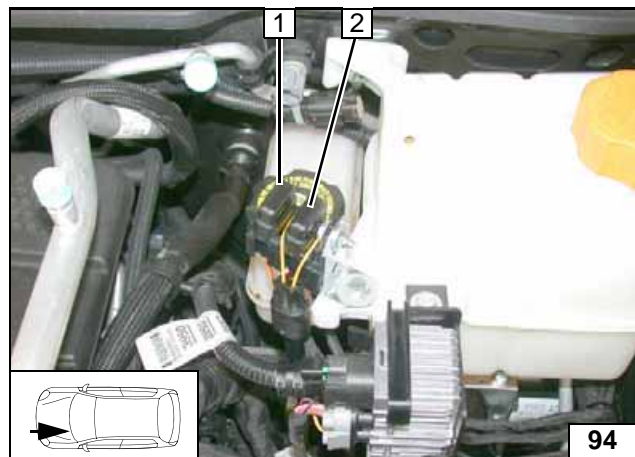

- 1 20A heater fuse F1
- 2 30A main fuse F2 of passenger compartment

Fuses of engine compartment



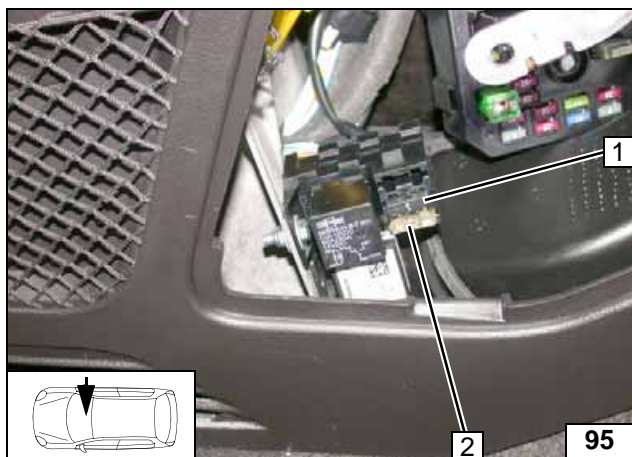

- 1 1A fuse F3 of heater control
- 2 25A fan fuse F4

Fuses of
passenger
compartment

