

Water Heater

Thermo Top Evo Parking Heater



Installation Documentation

Skoda Rapid

Validity

Manufacturer	Model	Type	EG-BE No./ ABE
Skoda	Rapid	NH	e11 * 2007 / 46 * 0250 * ...

Motorisation	Fuel	Transmission type	Output in kW	Displacement in cm ³	Engine code
1.6 TDI CR	Diesel	SG	77	1598	CAYC
1.6 TDI CR Green tec	Diesel	SG	77	1598	CAYC

SG = manual transmission

from Model Year 2013

Left-hand drive vehicle

Verified equipment variants: Manual / automatic air-conditioning system
 Front fog light
 Headlight washer system

Not verified: Passenger compartment monitoring

Total installation time: approx. 10 hours

Skoda Rapid

Table of Contents

Validity	1	Preparing Installation Location	15
Necessary Components	2	Preparing Heater	16
Installation Overview	2	Installing Heater	19
Information on Total Installation Time	2	Fuel	20
Information on Operating and Installation Instructions	3	Combustion Air	24
Information on Validity	4	Coolant Circuit	25
Technical Information	4	Underbody Trim	29
Explanatory Notes on Document	4	Guard Plate	30
Preliminary Work	5	Final Work	31
Heater Installation Location	5	Template for Fuel Standpipe	32
Preparing Electrical System	6	Operating Instructions for Manual Air-Conditioning	33
Electrical System	9	Operating Instructions for Automatic Air-Conditioning	34
Manual Air-Conditioning Fan Controller	10		
Automatic Air-Conditioning Fan Controller	12		
Digital Timer	14		
Remote Option (Telestart)	14		
Preparing Bracket	15		

Necessary Components

- Basic delivery scope *Thermo Top Evo* in accordance with price list
- Installation kit for Skoda Rapid 2013 Diesel: **1319164B**
- Additionally required in case of automatic air-conditioning: Automatic air-conditioning kit: **1315239C**
- Heater control in accordance with price list and upon consultation with end customer
- In case of Telestart, indicator lamp in accordance with price list and in consultation with end customer

Installation instructions

- Arrange for the vehicle to be delivered with the tank only about 1/4 full.
- The installation location of the push button in the case of Telestart or Thermo Call should be confirmed with the end customer.
- Depending on the space required and the vehicle manufacturer's instructions, we recommend the use of a vehicle battery with a higher electrical capacity.

Installation Overview

Legend:

1. Heater
2. Engine compartment fuse holder
3. Passenger compartment relay and fuse holder
4. IPCU (only in case of automatic air-conditioning)
5. Circulating pump
6. Digital timer
7. Metering pump

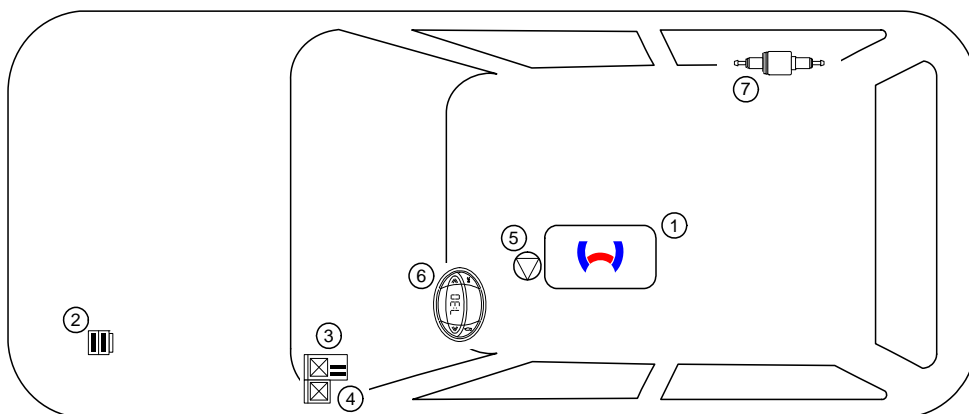

Information on Total Installation Time

The total installation time includes the time needed for mounting and demounting of the vehicle-specific components, the heater specific installation time and all other times required for the system integration and initial start-up of the heater.

The total installation time may vary for vehicle equipment other than provided.

Information on Operating and Installation Instructions

1 Important Information (not complete)

1.1 Installation and Repair



The improper installation or repair of Webasto heating and cooling systems can cause fire or the leakage of deadly carbon monoxide, leading to serious injury or death.



To install and repair Webasto heating and cooling systems you need to have completed a special company training course and have the appropriate technical documentation, special tools and special equipment.



Installation and repair may ONLY be carried out by persons trained and certified in a Webasto training course. NEVER try to install or repair Webasto heating or cooling systems if you have not completed a Webasto training course, you do not have the necessary technical skills and you do not have the technical documentation, tools and equipment available to ensure that you can complete the installation and repair work properly.

Only use genuine Webasto parts. See the Webasto air and water heaters accessories catalogue for this purpose.

1.2 Operation

To ensure safe operation, we recommend having the heater checked every two years by an authorised Webasto dealer, especially when used over a long period and/or under extreme environmental conditions.

Do not operate the heater in closed rooms due to the danger of poisoning and suffocation.

Always switch off the heater before refuelling.

The heater may only be used with the prescribed fuel Diesel (DIN EN 590) or petrol (DIN EN 228).

The heater may not be cleaned with a high-pressure cleaner.

1.3 Please note

ALWAYS follow all Webasto installation and operating instructions and observe all warnings.

To become familiar with and understand all functions and properties of the heater, the operating instructions must be read carefully and observed at all times.

For proper, safe installation and repair work, the installation instructions with all warnings and safety information must be carefully read and observed at all times. Please always contact a workshop authorised by Webasto for all installation and repair work.

Important

Webasto shall assume no liability for defects, damage and injuries resulting from a failure to observe the installation, repair and operating instructions of the information contained in them.

This liability exclusion particularly applies to improper installations and repairs, installations and repairs by untrained persons or in the case of a failure to use genuine spare parts.

The liability due to culpable disregard to life, limb or health and due to damage or injuries caused by a wilful or reckless breach of duty remain unaffected, as does the obligatory product liability.

Installation should be carried out according to the general, standard rules of technology. Unless specified otherwise, fasten hoses, lines and wiring harnesses to original vehicle lines and wiring harnesses using cable ties. Insulate loose wire ends and tie back. Connectors on electronic components must audibly snap into place during assembly.

Sharp edges should be fitted with rub protection. Spray unfinished body areas, e.g. drilled holes, with anti-corrosion wax (Tectyl 100K, Order No. 111329).

Observe the instructions and guidelines of the respective vehicle manufacturer for demounting and mounting vehicle specific components!

The initial startup is to be executed with the Webasto Thermo Test Diagnosis.

When installing a programmable control module (e.g. a PWM Gateway), the corresponding settings must be checked or adjusted.

2 Statutory regulations governing installation

Guidelines	Thermo Top Evo
Heating Directive ECE R122	E1 00 0258
EMC Directive ECE R10	E1 04 5627

Note

The regulations of these guidelines are binding in the scope of the Directive 70/156/EEC and/or 2007/46/EC (for new vehicle models from 29/04/2009) and should also be observed in countries in which there are no special regulations.

Important

Failure to follow the installation instructions will result in the invalidation of the type approval for the heater and therefore invalidation of the general **homologation of the vehicle**.

Note

The heater is licensed in accordance with paragraph 19, section 3, No. 2b of the StVZO (German Road Traffic Licensing Authority).

2.1 Excerpt from ECE regulation 122 (heating system) paragraph 5 for the installation of the heater

Beginning of excerpt.

ANNEX VII

REQUIREMENTS FOR COMBUSTION HEATERS AND THEIR INSTALLATION

1. GENERAL REQUIREMENTS

1.7.1. A clearly visible tell-tale in the operator's field of view shall inform when the combustion heater is switched on or off.

2. VEHICLE INSTALLATION REQUIREMENTS

2.1. Scope

2.1.1. Subject to paragraph 2.1.2. combustion heaters shall be installed according to the requirements of this Annex.

2.1.2. Vehicles of category O having liquid fuel heaters are deemed to comply with the requirements of this Annex.

2.2. Positioning of heater

2.2.1. Body sections and any other components in the vicinity of the heater must be protected from excessive heat and the possibility of fuel or oil contamination.

2.2.2. The combustion heater shall not constitute a risk of fire, even in the case of overheating. This requirement shall be deemed to be fulfilled if the installation ensures an adequate distance to all parts and suitable ventilation, by the use of fire resistant materials or by the use of heat shields.

2.2.3. In the case of M2 and M3 vehicles, the heater must not be positioned in the passenger compartment. However, an installation in an effectively sealed envelope which also complies with the conditions in paragraph 2.2.2 may be used.

2.2.4. The label referred to in paragraph 1.4 or a duplicate, must be positioned so that it can be easily read when the heater is installed in the vehicle.

2.2.5. Every reasonable precaution should be taken in positioning the heater to minimise the risk of injury and damage to personal property.

2.3. Fuel supply

2.3.1. The fuel filler must not be situated in the passenger compartment and must be provided with an effective cap to prevent fuel spillage.

2.3.2. In the case of liquid fuel heaters, where a supply separate to that of the vehicle is provided, the type of fuel and its filler point must be clearly labelled.

2.3.3. A notice, indicating that the heater must be shut down before refuelling, must be affixed to the fuelling point. In addition a suitable instruction must be included in the manufacturer's operating manual.

2.4. Exhaust system

2.4.1. The exhaust outlet must be located so as to prevent emissions from entering the vehicle through ventilators, heated air inlets or opening windows.

2.5. Combustion air inlet

2.5.1. The air for the combustion chamber of the heater must not be drawn from the passenger compartment of the vehicle.

2.5.2. The air inlet must be so positioned or guarded that blocking by rubbish or luggage is unlikely.

2.6. Heating air inlet

2.6.1. The heating air supply may be fresh or recirculated air and must be drawn from a clean area not likely to be contaminated by exhaust fumes emitted either by the propulsion engine, the combustion heater or any other vehicle source.

2.6.2. The inlet duct must be protected by mesh or other suitable means.

2.7. Heating air outlet

2.7.1. Any ducting used to route the hot air through the vehicle must be so positioned or protected that no injury or damage could be caused if it were to be touched.

2.7.2. The air outlet must be so positioned or guarded that blocking by rubbish or luggage is unlikely.

End of excerpt.

In multilingual versions the German language is binding.

Skoda Rapid

Information on Validity

This installation documentation applies to Skoda Rapid Diesel vehicles - for validity, see page 1 - from model year 2013 and later, assuming technical modifications to the vehicle do not affect installation, any liability claims excluded. Depending on the vehicle version and equipment, modifications may be necessary during installation with respect to this installation documentation.

Vehicle and engine types, equipment variants and other specifications not listed in this installation documentation have not been tested. However, installation according to this installation documentation may be possible.

Technical Information

Special tools

- Hose clamp pliers for self-clamping hose clamps
- Hose clamp pliers for Clic hose clamps of type W
- Automatic wire stripper 0.2 - 6mm²
- Crimping pliers for cable lug / tab connector 0.5 - 6mm²
- Torque wrench for 2.0 - 10 Nm
- Hose clamping pliers
- Metric thread-setter kit
- Webasto Thermo Test Diagnosis with current software

Dimensions

- All dimensions are in mm

Tightening torque values

- Tightening torque values of 5x13 heater bolts and 5x11 heater stud bolts = 8Nm.
- Tightening torque values of 5x15 retaining plate of water connection piece bolts = 7Nm.
- Tighten other bolt connections in accordance with manufacturer's instructions or in accordance with state-of-the-art-technology.

Explanatory Notes on Document

You will find an identification mark on the outside top right corner of the page in question to provide you with a quick overview of the individual working steps.

Special features are highlighted using the following symbols:

Mechanical system



Specific risk of injury or fatal accidents



Electrical system



Specific risk due to electrical voltage



Coolant circuit



Specific risk of damage to components



Combustion air

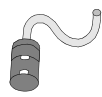

Specific risk of fire or explosion



Fuel

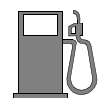

Reference to general installation instructions of the Webasto components or to the manufacturer's vehicle-specific documents



Reference to a special technical feature



Exhaust gas



The arrow in the vehicle icon indicates the position on the vehicle and the viewing angle

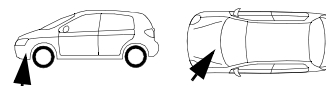

Software



Tightening torque according to the manufacturer's vehicle-specific documents



Skoda Rapid

Preliminary Work

Vehicle

- Open the fuel tank cap.
- Ventilate the fuel tank.
- Close the fuel tank cap again.
- Depressurise the cooling system.
- Disconnect and remove the battery.
- Remove the windscreen wiper.
- Remove the coolant reservoir cap.
- Remove the coolant reservoir partition wall.
- Remove the windscreen wiper motor.
- Remove the air filter together with the intake hose.
- Remove the underride protection.
- Remove the right vehicle underbody trim.
- Fold up the seating surface of the rear bench seat.
- Open the tank-fitting service lid.
- Remove the light switch.
- Detach the central electrical box under the steering wheel.
- Remove the side instrument panel trim on the left.
- Remove the A/C control panel (only with automatic air-conditioning).

Heater

- Remove years that do not apply from the type and duplicate label.
- Attach the duplicate label (type label) in the appropriate place in the engine compartment.



Heater Installation Location

1 Heater

Installation
location

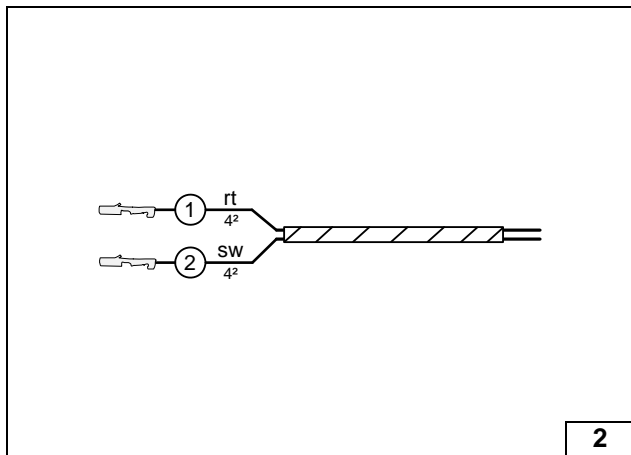

Preparing Electrical System

Wire sections retain their numbering in the entire document.

Produce all following electrical connections as shown in the wiring diagram.

- ① Red (rt) wire of fan wiring harness
- ② Black (sw) wire of fan wiring harness



Assigning wires

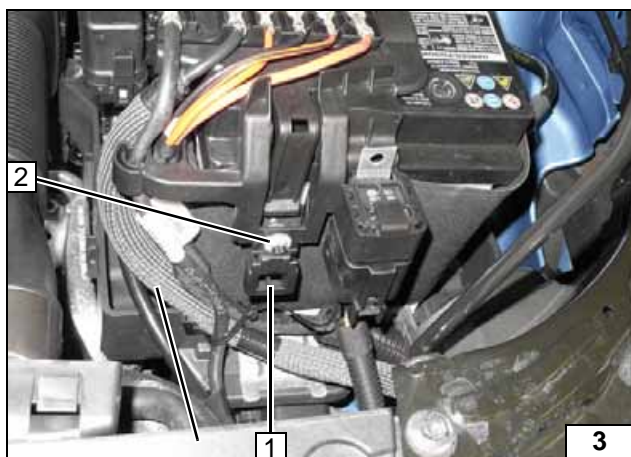

5.5 mm dia. hole at position 2. When drilling, watch components located behind!

- 1 Retaining plate for engine compartment fuse holder
- 2 M5x16 bolt, large diameter washer [2x], nut



Installing retaining plate

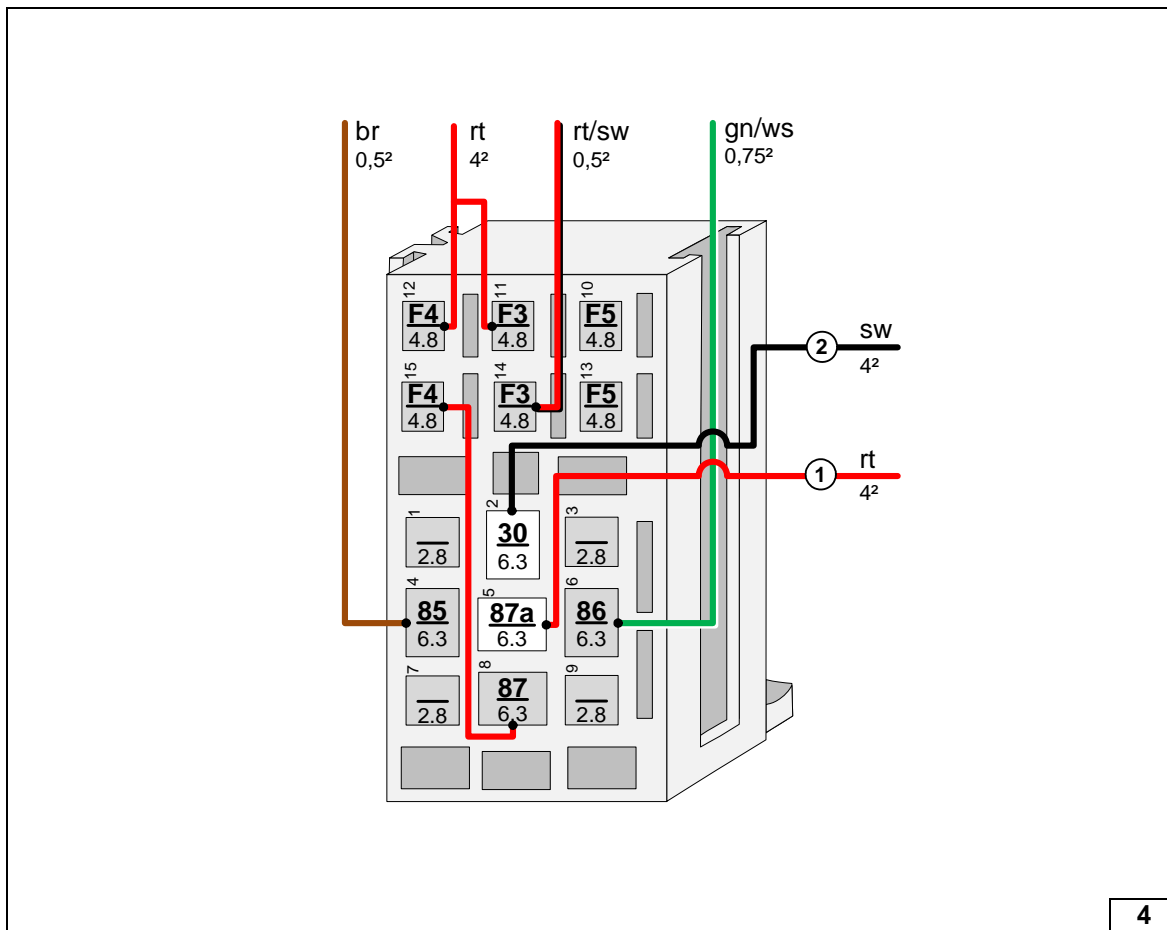

Connecting wires to passenger compartment relay and fuse holder

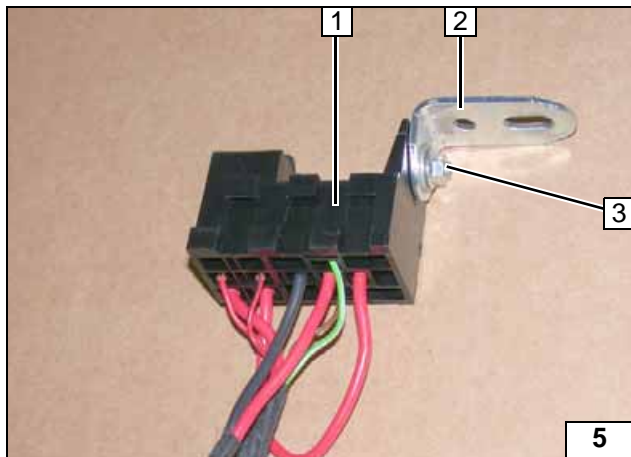

- 1 Passenger compartment relay and fuse holder
- 2 Angle bracket
- 3 M5x16 bolt, large diameter washer [2x], nut



Premounting relay and fuse holder

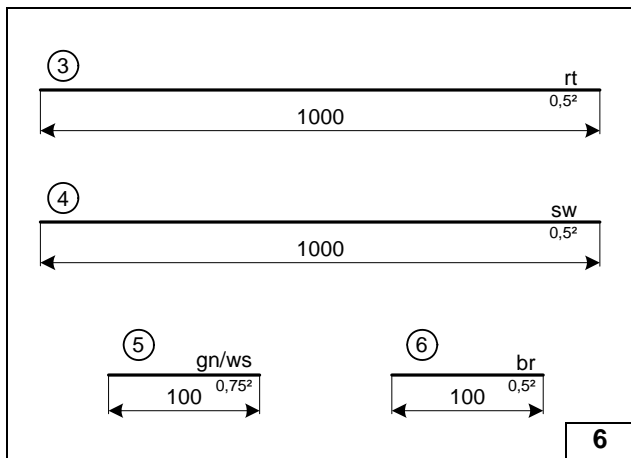

Only in case of automatic air-conditioning

Pull wire sections ③ and ④ into provided protective sleeving.



Assigning wires

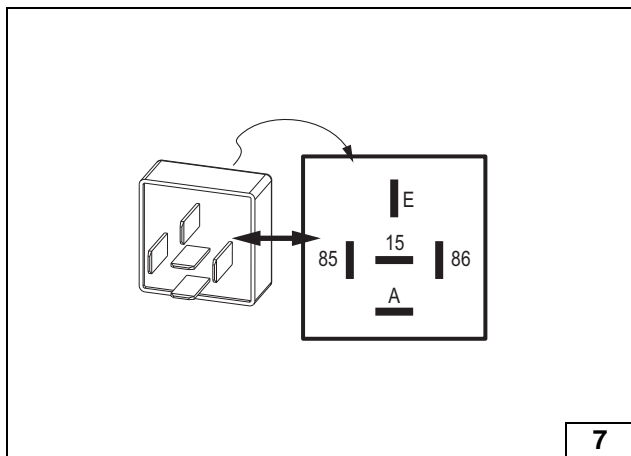

The settings must be checked during the start-up of the heater and adjusted if necessary.

Settings:

- Duty cycle: 100%
- Frequency: not relevant
- Voltage: 3.6V
- Function: High-side



Checking IPCU

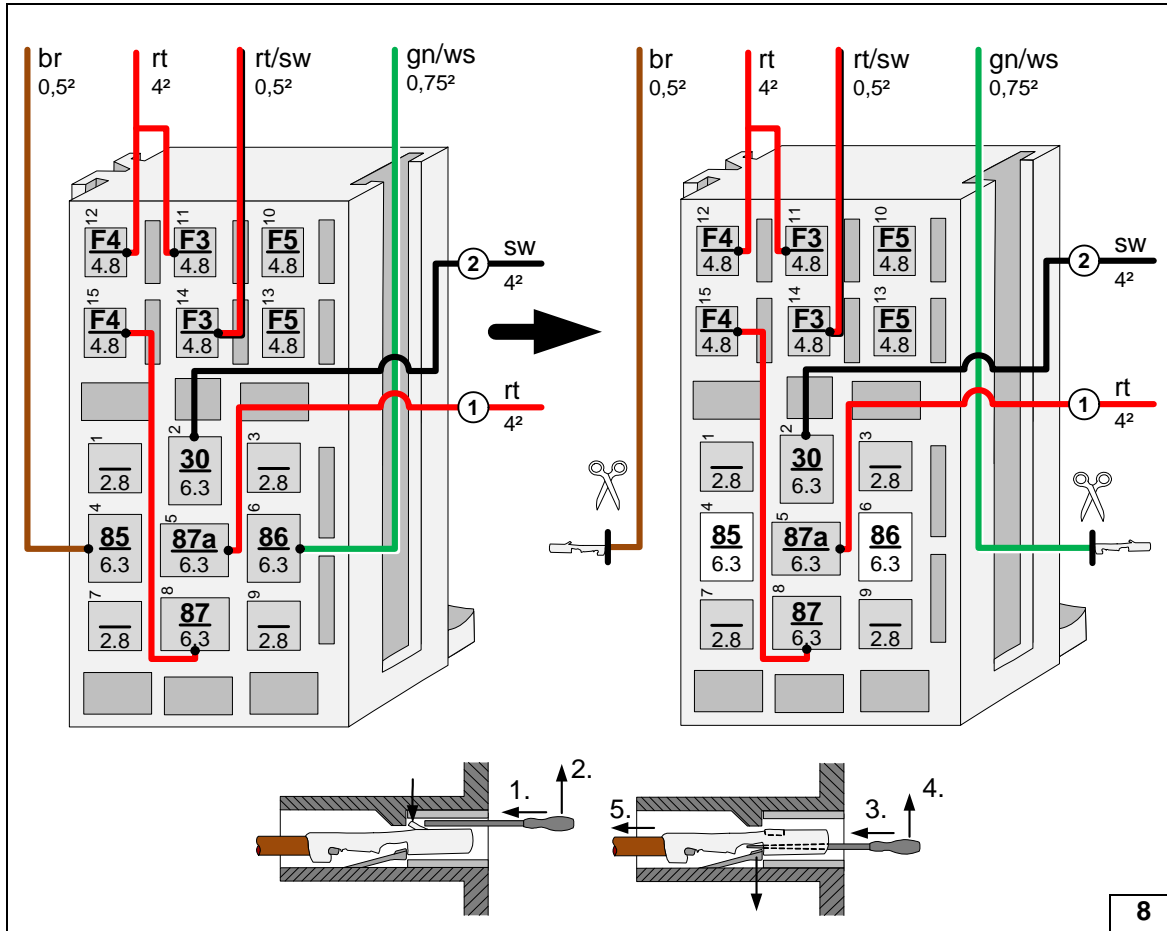

Preparing relay and fuse holder of passenger compartment

8

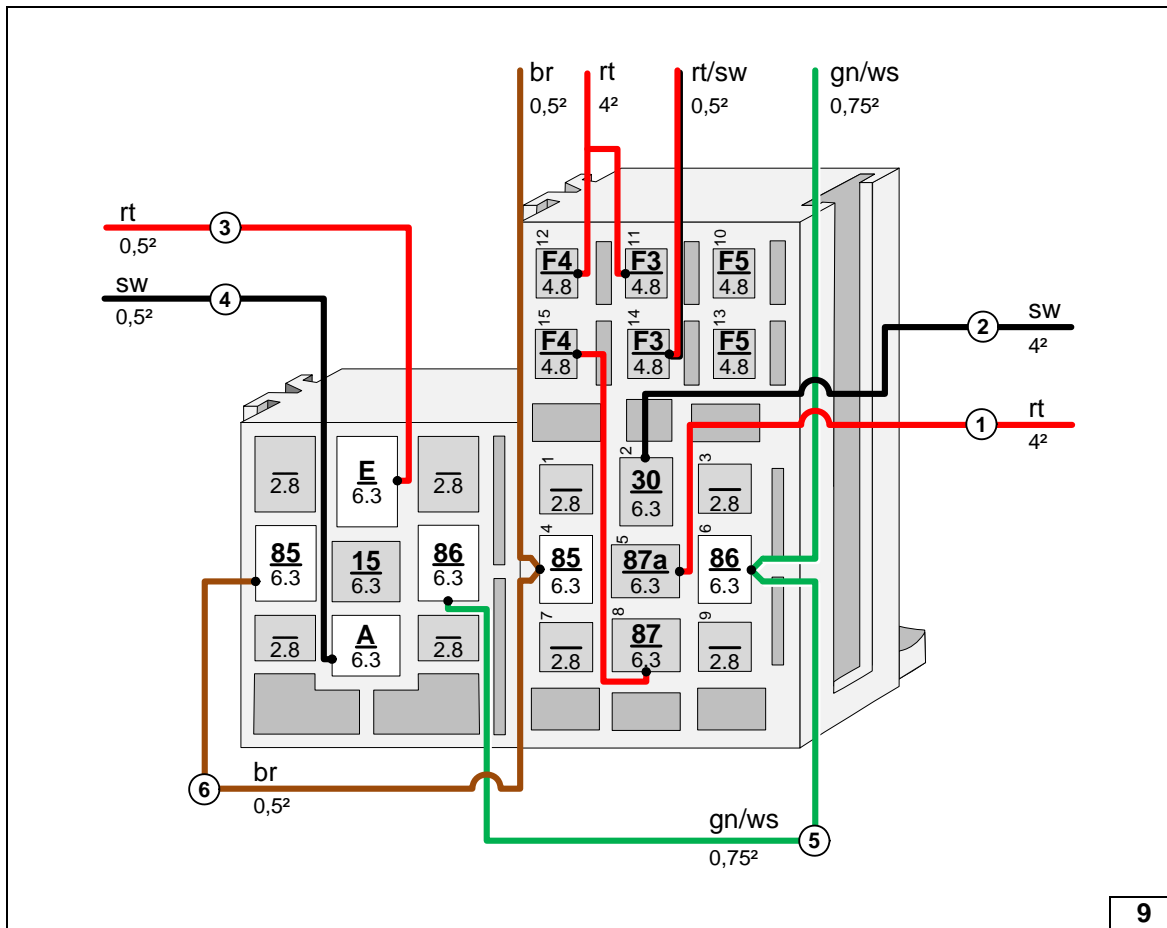

Interlocking socket of IPCU and relay and fuse holder of passenger compartment and connecting wires

9

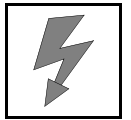

Electrical System

Positive wire

- 1 Positive distributor of battery
- 2 Positive wire

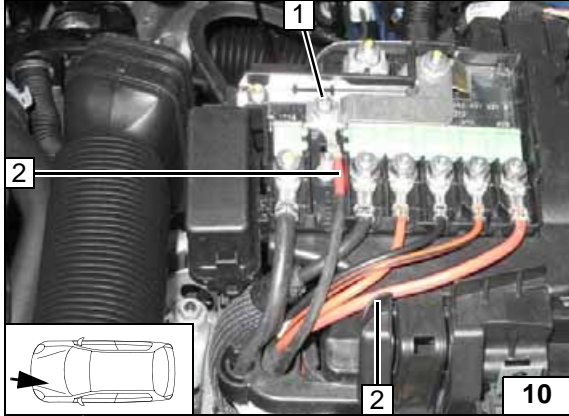

Wiring harness pass through of passenger compartment

- 1 Protective rubber plug
- 2 Wiring harnesses of heater, heater control

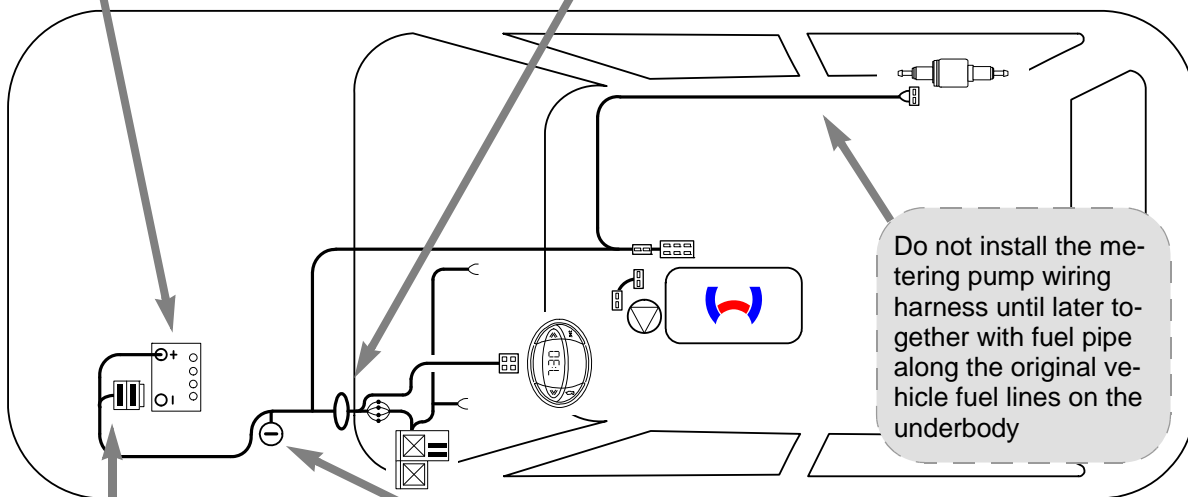
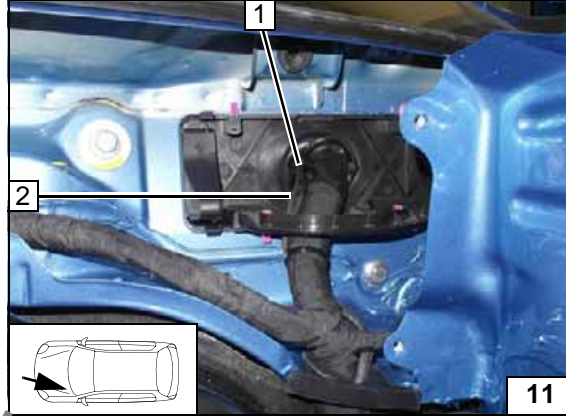

Wiring harness routing diagram

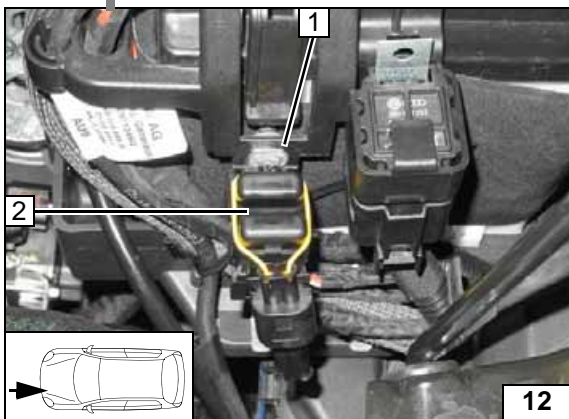

Fuse holder of engine compartment

- 1 Retaining plate for fuse holder
- 2 F1-2 fuses mounted

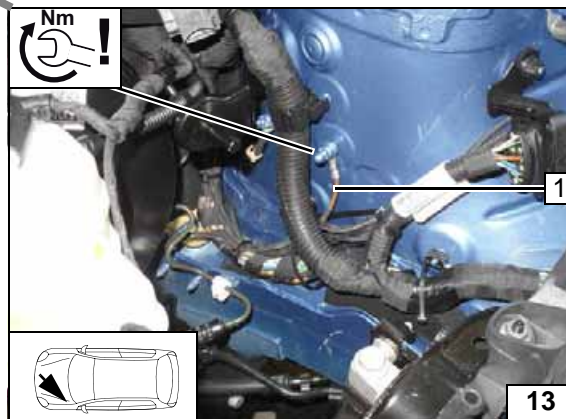

Earth wire

- 1 Earth wire on original vehicle earth support point





Manual Air-Conditioning Fan Controller

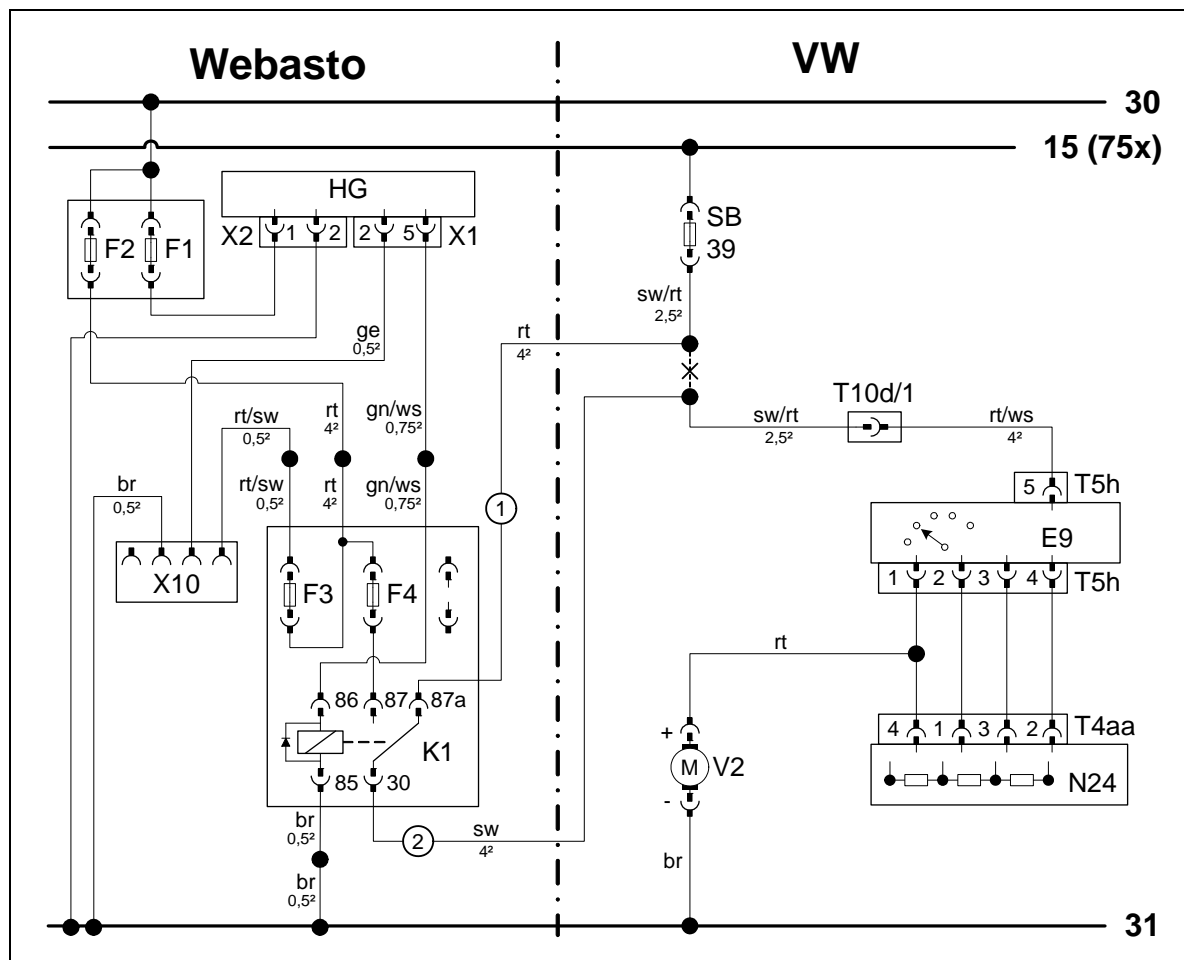

Wiring diagram

Webasto components		Vehicle components		Colours and symbols	
HG	Heater TT-Evo	SB39	30A fuse	rt	red
X1	6-pin heater connector	T...	Connector	ws	white
X2	2-pin heater connector	E9	Switch unit	sw	black
F1	20A fuse	V2	Fan motor	br	brown
F2	30A fuse	N24	Resistor group	gn	green
X10	4-pin connector of heater control			ge	yellow
F3	1A fuse				
F4	25A fuse			X	Cutting point
K1	Fan relay			Wiring colours may vary.	

Legend

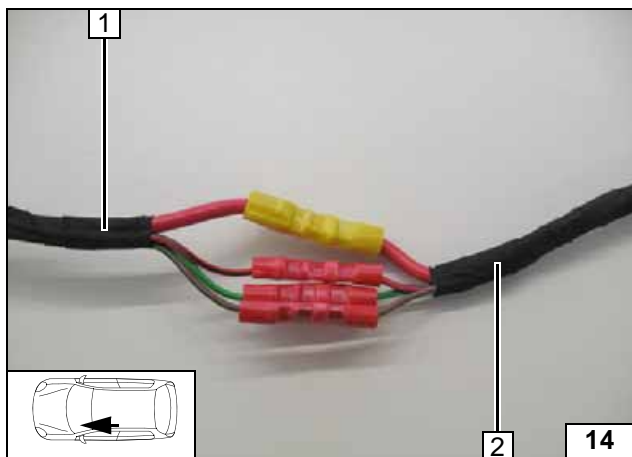

- 1 Wiring harness of passenger compartment relay and fuse holder
- 2 Wiring harness of heater

Connecting wiring harnesses using same colour wires

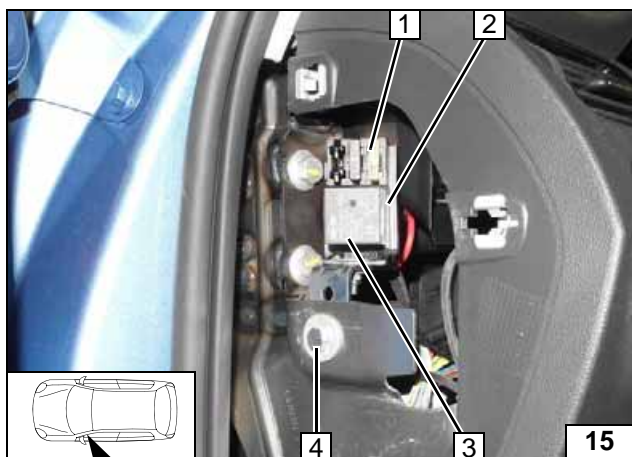

Insert 10mm shim between body and angle bracket at position 4.



- 1 25A fuse F4
- 2 Passenger compartment relay and fuse holder
- 3 K1 relay
- 4 M6x25 bolt, large diameter washer, existing hole, 10mm shim, angle bracket, flanged nut

Mounting passenger compartment relay and fuse holder

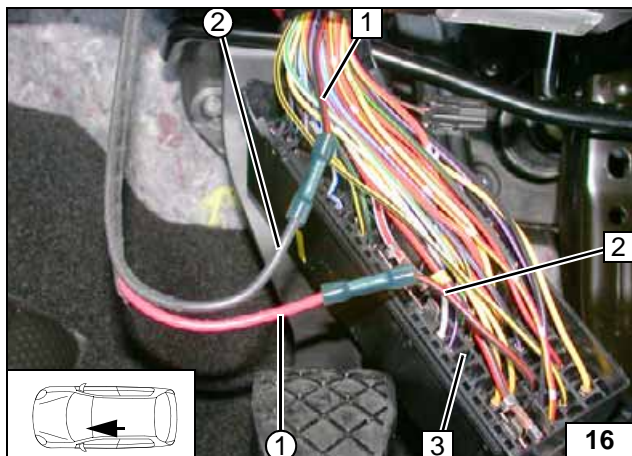

- 1 Black/red (sw/rt) wire of fan unit
- 2 Black/red (sw/rt) wire of fuse SB39
- 3 Fuse carrier of passenger compartment
- ① Red (rt) wire from K1/87a fan wiring harness
- ② Black (sw) wire from K1/30 fan wiring harness

Connecting passenger compartment fuse carrier



Automatic Air-Conditioning Fan Controller

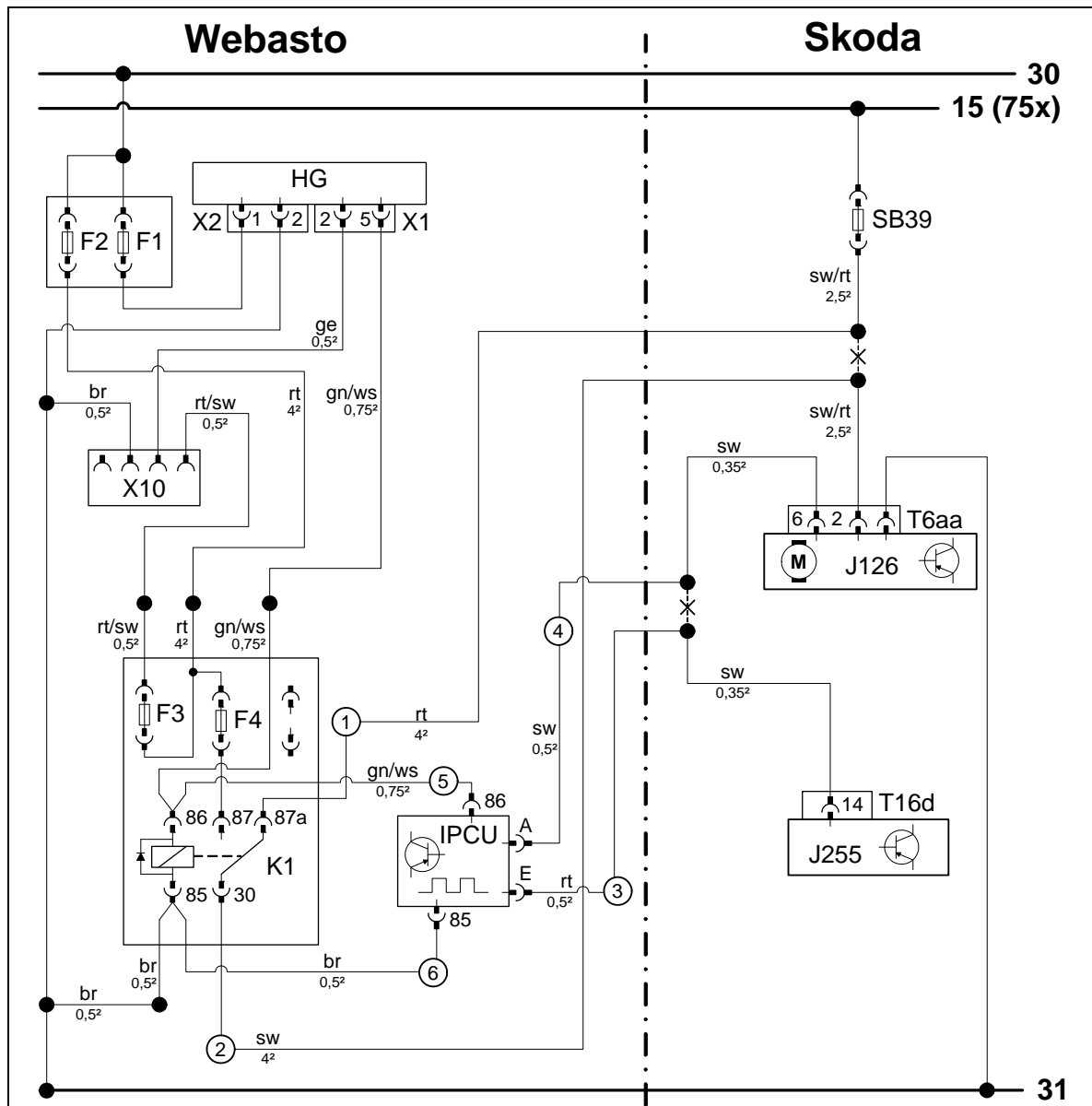

Wiring diagram

Webasto components		Vehicle components		Colours and symbols	
HG	Heater TT-Evo	SB39	30A fuse	rt	red
X1	6-pin heater connector	T...	Connector	ws	white
X2	2-pin heater connector	J126	Fan unit	sw	black
F1	20A fuse	J255	A/C control panel	br	brown
F2	30A fuse			gn	green
X10	4-pin connector of heater control			ge	yellow
F3	1A fuse				
F4	25A fuse				
K1	Fan relay				
IPCU	Pulse width modulator				
IPCU settings:					
Duty cycle: 100%					
Frequency: not relevant					
Voltage: 3.6 V					
Function: High-side					
				X	Cutting point
Wiring colours may vary.					

Legend

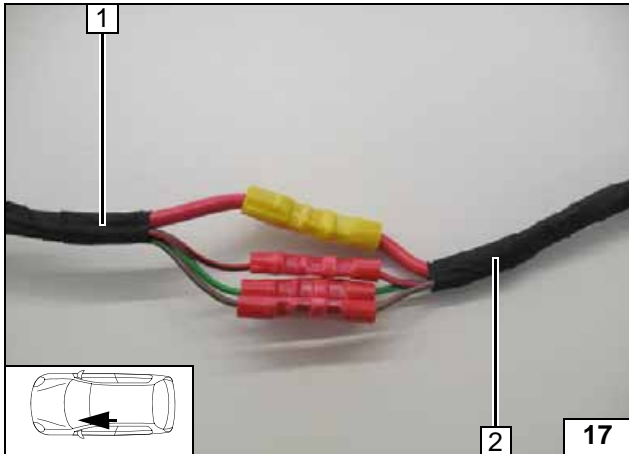

- 1 Wiring harness of passenger compartment relay and fuse holder
- 2 Wiring harness of heater

Connecting wiring harnesses using same colour wires

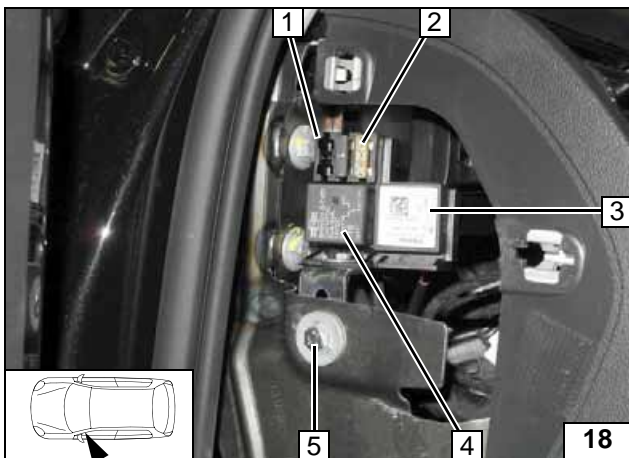

Insert 10mm shim between body and angle bracket at position 5.

- 1 Passenger compartment relay and fuse holder
- 2 25A fuse F4
- 3 IPCU
- 4 K1 relay
- 5 M6x25 bolt, large diameter washer, existing hole, 10mm shim, angle bracket, flanged nut

Mounting passenger compartment relay and fuse holder

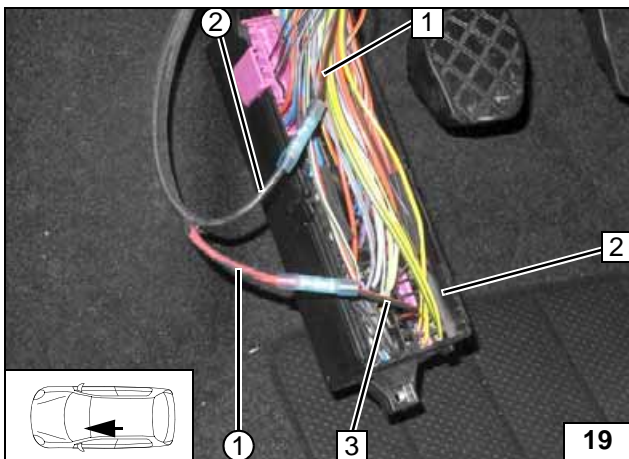

- 1 Black/red (sw/rt) wire of fan unit
- 2 Fuse carrier of passenger compartment
- 3 Black/red (sw/rt) wire of fuse SB39
- ① Red (rt) wire from K1/87a fan wiring harness
- ② Black (sw) wire from K1/30 fan wiring harness

Connecting passenger compartment fuse carrier

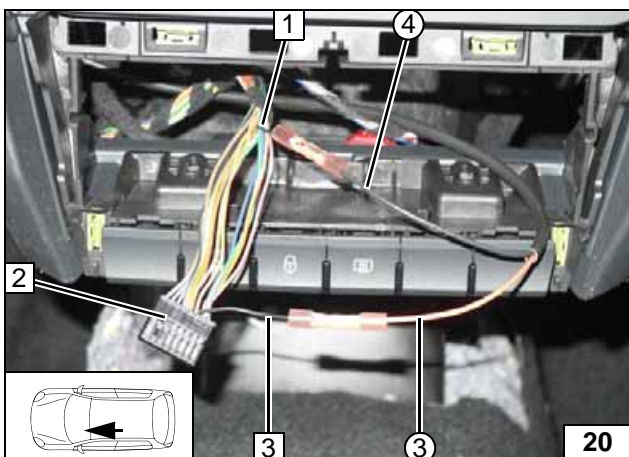

- 1 Black (sw) wire of T6aa, Pin 6
- 2 Connector of A/C control unit
- 3 Black (sw) wire of connector T16d, Pin14
- ③ Red (rt) wire of IPCU/E
- ④ Black (sw) wire of IPCU/A

Connection of A/C control unit

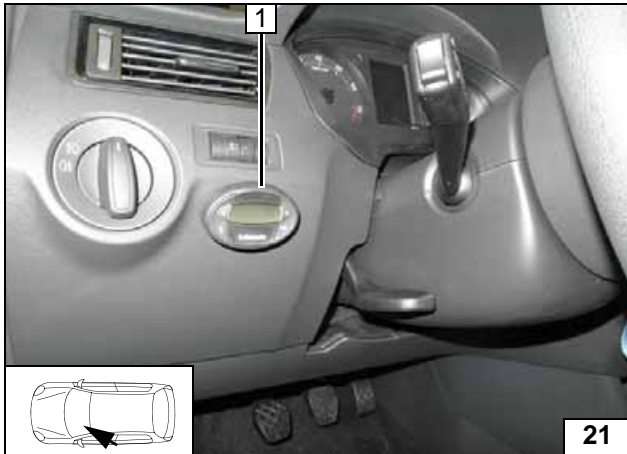

Digital Timer

- 1 Digital timer



Installing digital timer

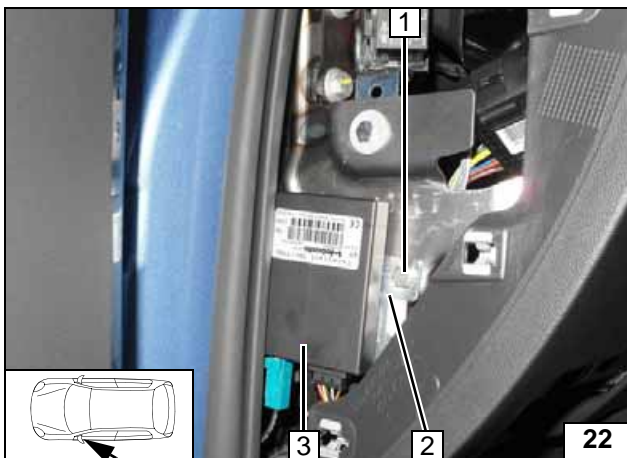

Remote Option (Telestart)

- 1 M6x20 bolt, flanged nut, existing hole
- 2 Bracket
- 3 Receiver



Installing receiver

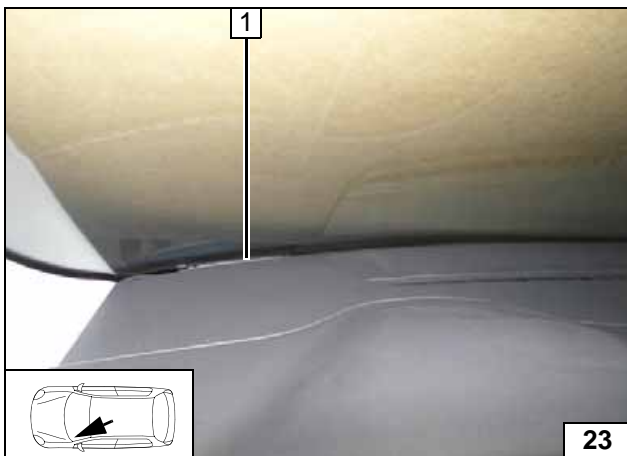

- 1 Antenna

Installing antenna

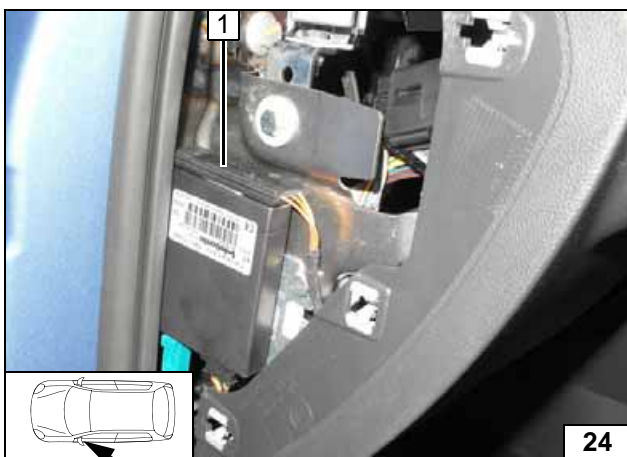

Temperature sensor T100 HTM

Fasten temperature sensor 1 with double-sided adhesive tape.



Installing temperature sensor

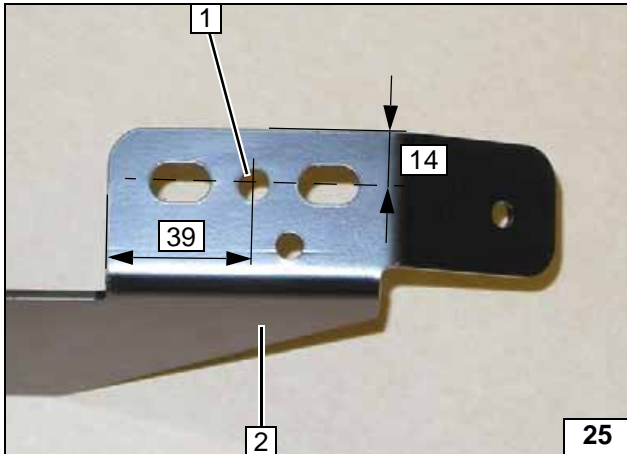

Preparing Bracket

- 1 8mm dia. hole
- 2 Bracket

Hole in bracket

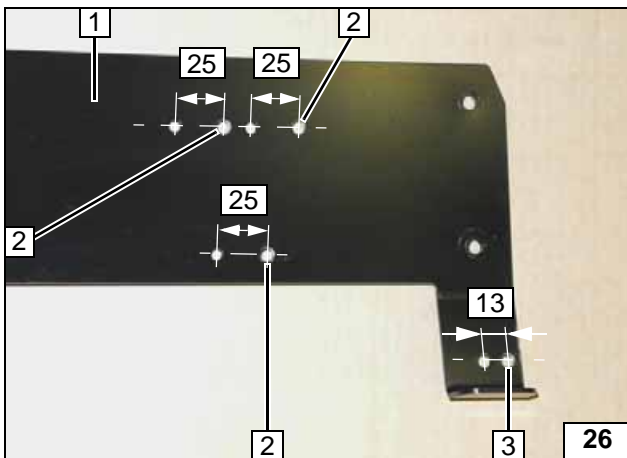

Shift hole pattern for attachment of heater at position 2 by 25mm. Shift hole pattern for attachment of exhaust silencer at position 3 by 13mm.

- 1 Bracket
- 2 6mm dia. hole [3x]
- 3 7mm dia. hole

Holes in bracket

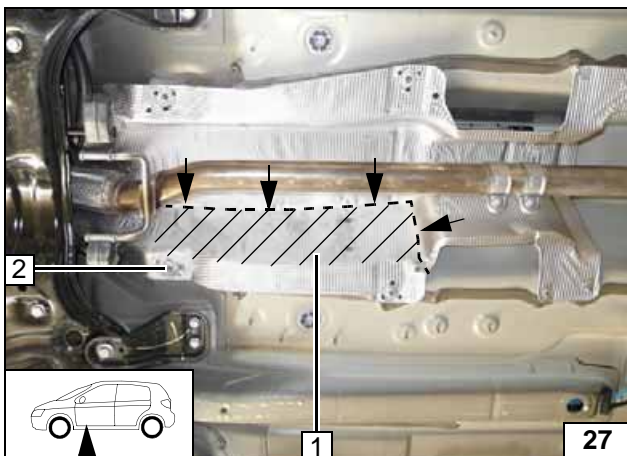

Preparing Installation Location

Route wiring harness of metering pump and wiring harness of heater in heat protection hose. Place heat shield plate 1 on the tunnel in the area of the bracket.

- 2 Remove and discard retaining clamp

Removing clamp

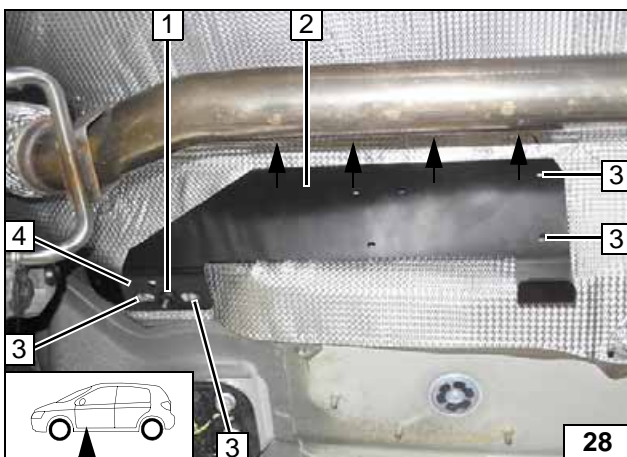

Adjust tab 4 of bracket to contour of underbody. Insert bracket 2 at position 1 and horizontally adjust it upwards as far as possible.

- 1 Original vehicle stud bolt
- 3 Copy hole pattern to heat shield plate [4x]

Copying hole pattern

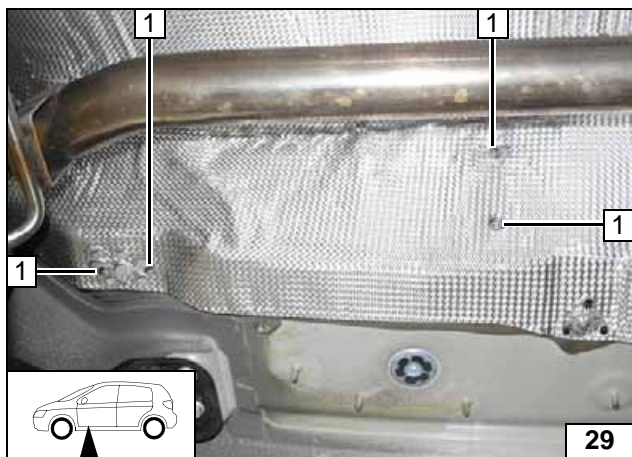

Remove bracket. Use 10mm drilling depth limitation. Enlarge holes in the heat shield plate to 12mm.

- 1 9.1mm dia. hole in body; rivet nut [4x each]



Installing rivet nut

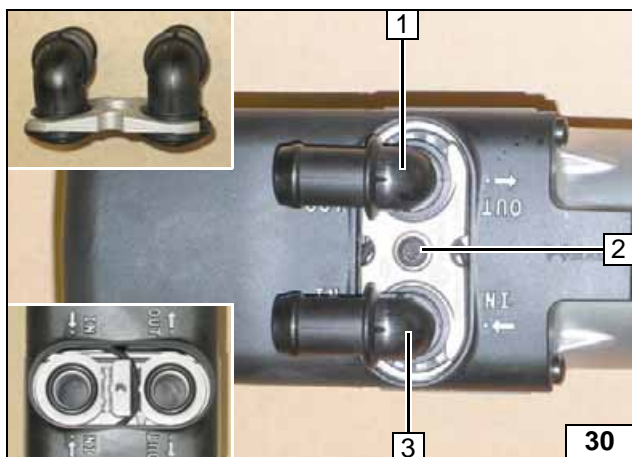

Preparing Heater

- 1 Water connection piece, sealing ring [2x each]
- 2 5x15 self-tapping bolt, retaining plate of water connection piece



Installing water connection piece

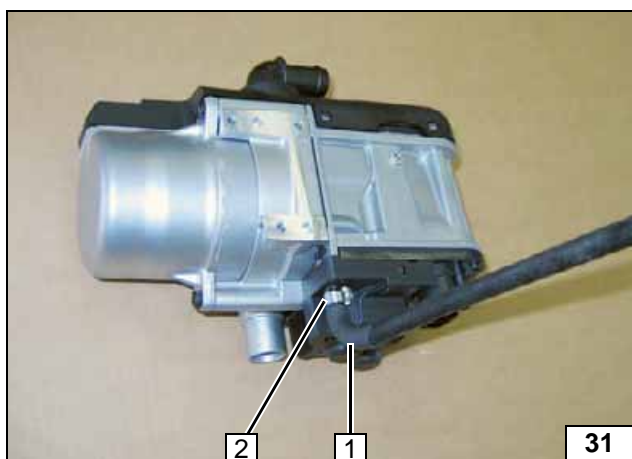

- 1 Moulded hose (fuel)
- 2 10 mm dia. clamp

Premounting heater

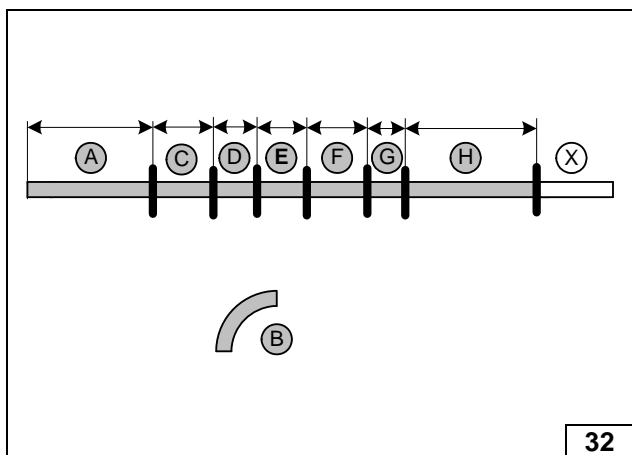

Discard section X.
Hose B = 90°, 18 mm dia. moulded hose

- A = 420
- C = 170
- D = 80
- E = 115
- F = 140
- G = 60
- H = 485

Cutting hoses to length

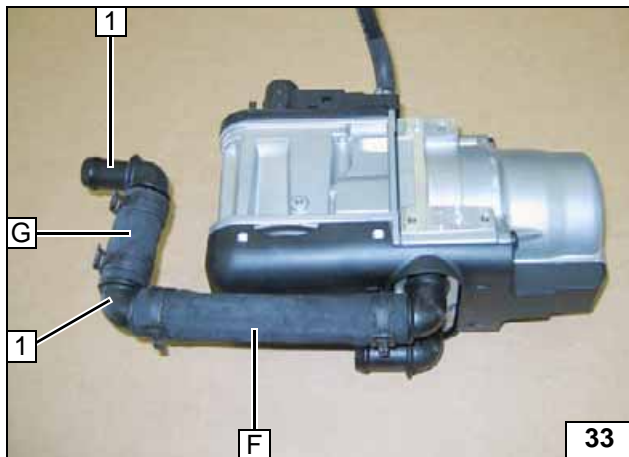

All spring clips = 25mm dia.

- 1 90°, 18x18mm dia. connecting pipe [2x]



Premounting heater

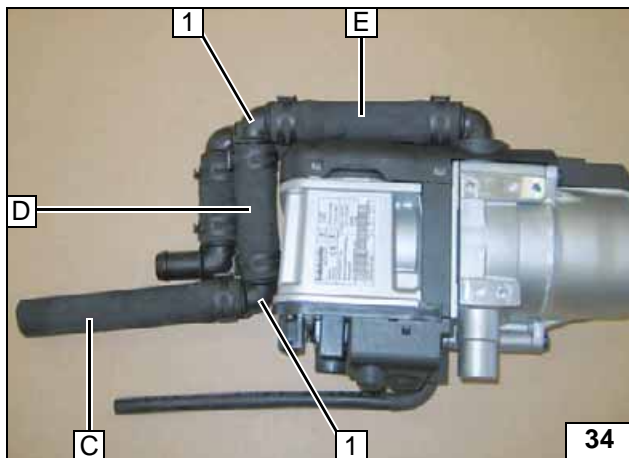

All spring clips = 25 mm dia.

- 1 90°, 18x18mm dia. connecting pipe [2x]



Premounting heater

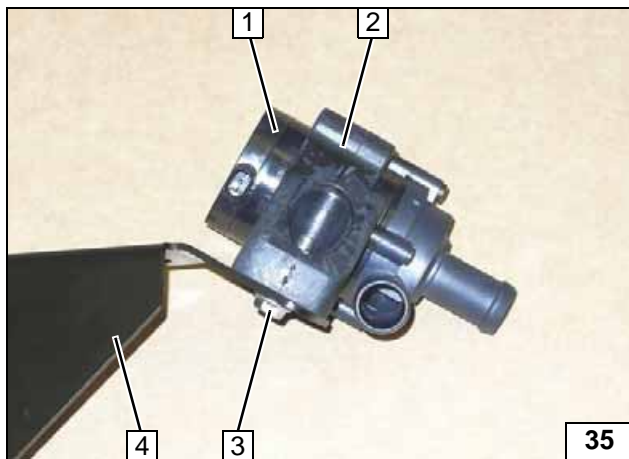

- 1 Circulating pump
- 2 Circulating pump mounting
- 3 M6x25 bolt, large diameter washer, flanged nut
- 4 Bracket

Premounting circulating pump

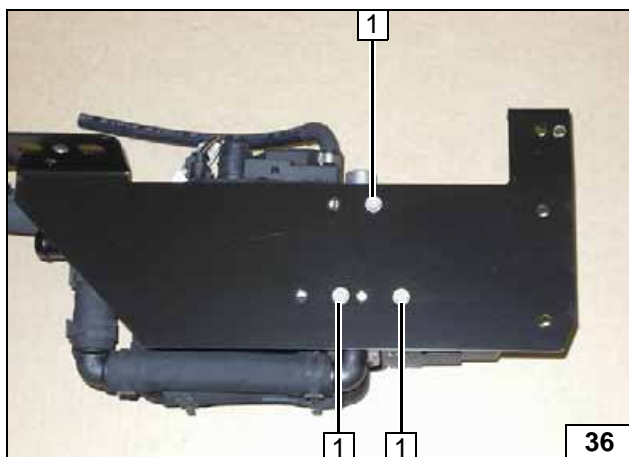

- 1 5x13 self-tapping bolt [3x]

Installing bracket

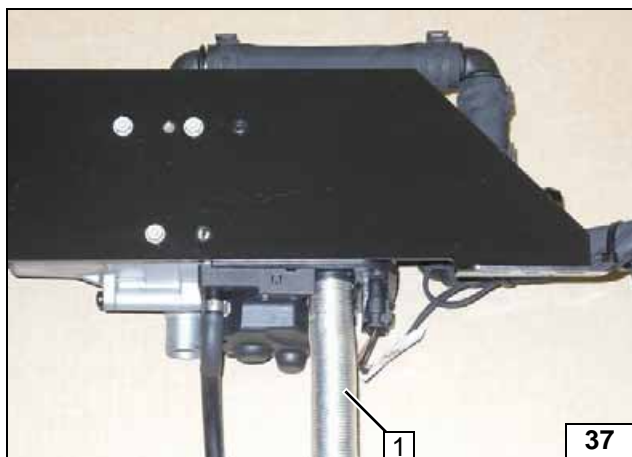

1 Combustion air pipe



Installing combustion air pipe

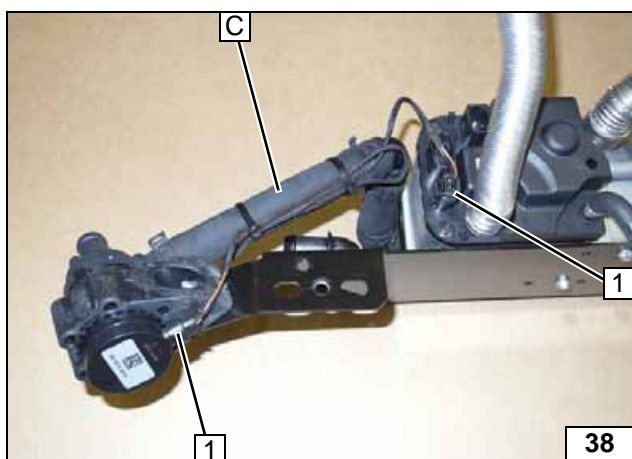

1 Wiring harness of circulating pump [2x]

Connecting circulating pump

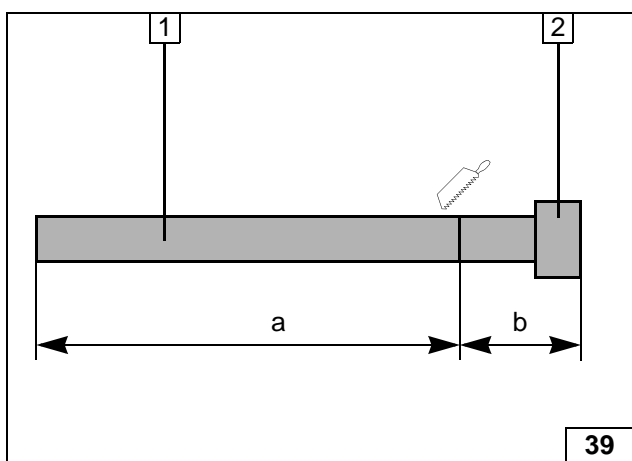

1 Exhaust pipe
a = 100
2 Exhaust end section
b = 50

Preparing exhaust pipe

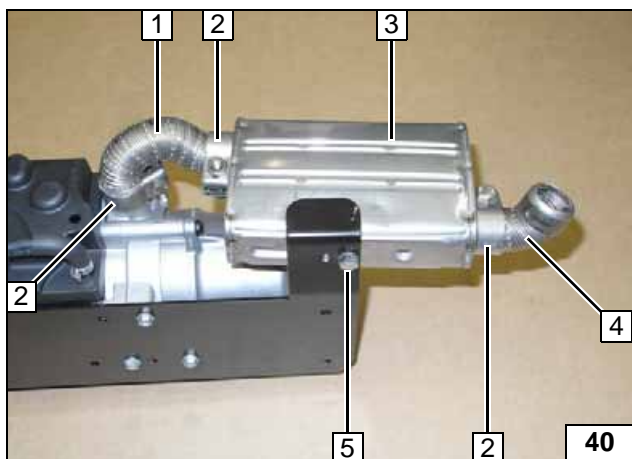

1 Exhaust pipe
2 Hose clamp [3x]
3 Exhaust silencer
4 Exhaust end section
5 M6x16 bolt, spring lockwasher

Installing exhaust system

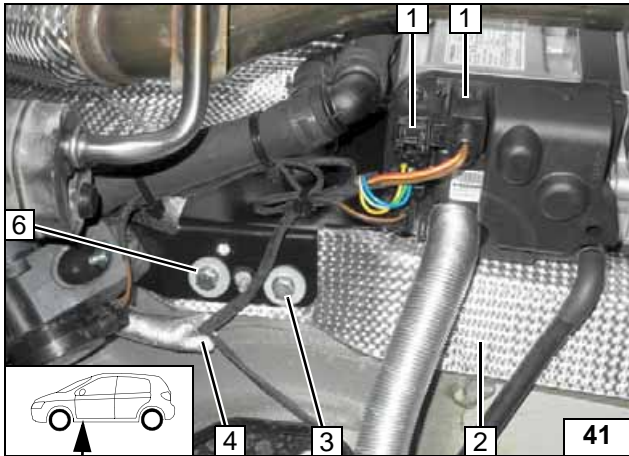
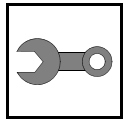

Installing Heater

- 1 Mount wiring harness of heater [2x]
- 2 Heat shield plate
- 3 M6x20 bolt, spring lockwasher, large diameter washer
- 4 Wiring harness of heater and wiring harness of metering pump in heat protection hose
- 6 Loosely install M6x30 bolt (will be removed again later)

Installing heater

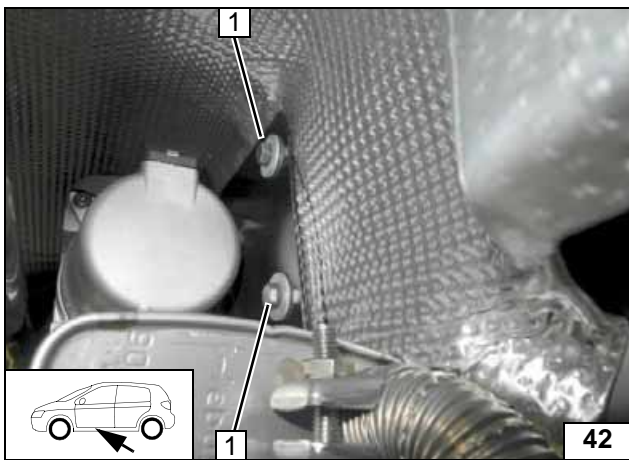

- 1 M6x20 bolt, spring lockwasher, large diameter washer [2x each]

Installing heater

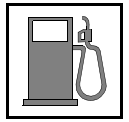

Fuel

CAUTION!

Open the vehicle's fuel tank cap, ventilate the tank and then re-close the tank lock.

Catch any fuel running off with an appropriate container.

Route fuel line and metering pump wiring harness so that they are protected against stone impact. Unless specified otherwise, always fasten using cable ties.

Provide rub protection for fuel line and wiring harness in areas where there are sharp edges.

WARNING!

The fuel line and wiring harness are routed to the metering pump as shown in the wiring harness routing diagram.

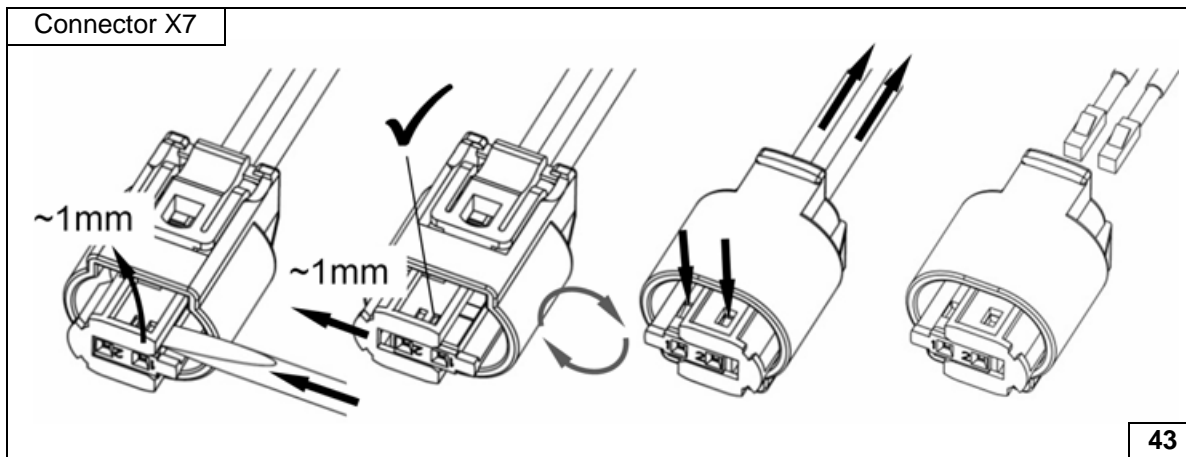

Dismantling connector of metering pump

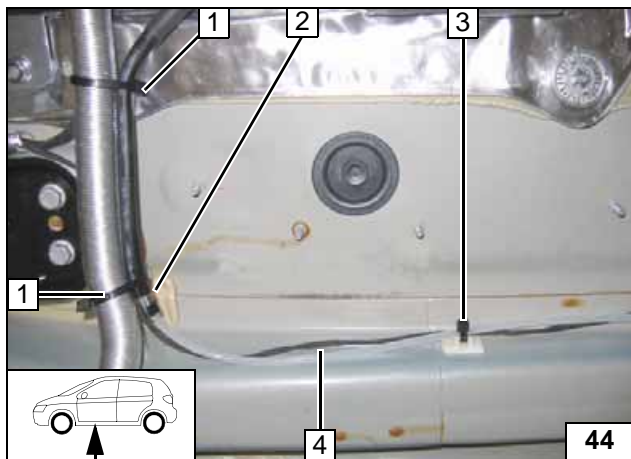

Remove grease from gluing point!

- 1 Cable tie [2x]
- 2 Moulded hose (premounted), 10 mm dia. clamp, fuel line
- 3 Adhesive base, clip-type cable tie
- 4 Fuel line, metering pump wiring harness



Heater connection and routing

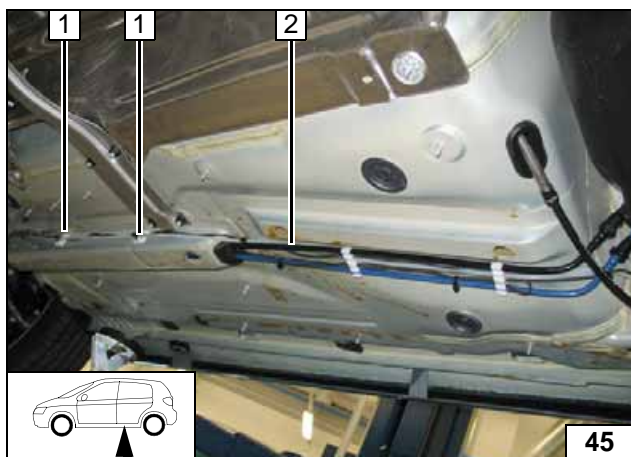

Route fuel line and wiring harness of metering pump 2 to the installation location of the metering pump along original vehicle fuel lines. Remove grease from gluing points

- 1 Adhesive base, cable tie [2 each]



Connect-
ing heater

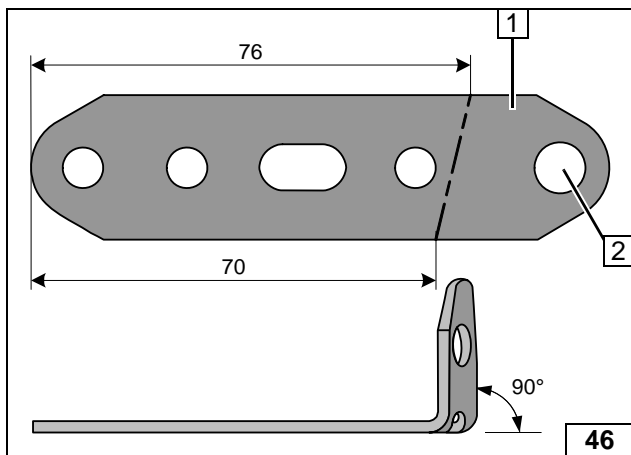

- 1 Perforated bracket
- 2 Drill hole to 8.5mm dia.

Preparing perforated bracket

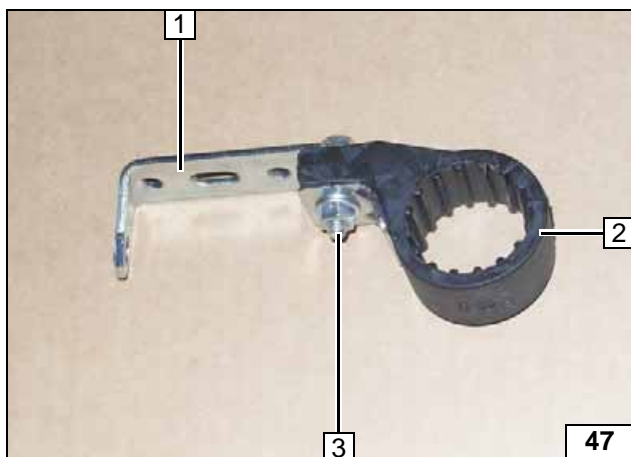

- 1 Perforated bracket
- 2 Metering pump mount
- 3 M6x25 bolt, support angle bracket, flanged nut

Preassembling mount of metering pump

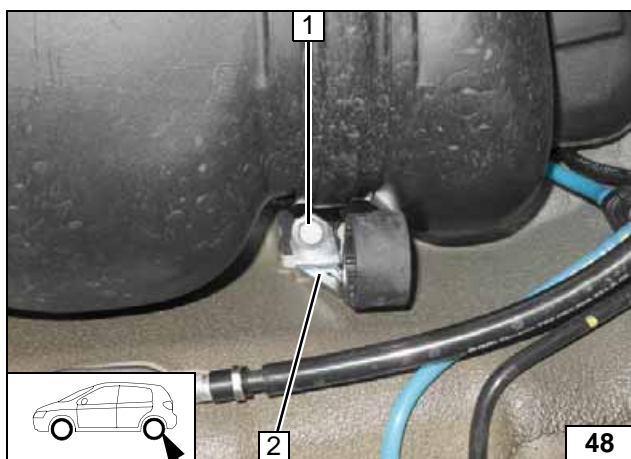

- 1 Original vehicle bolt
- 2 Perforated bracket

Installing metering pump mount

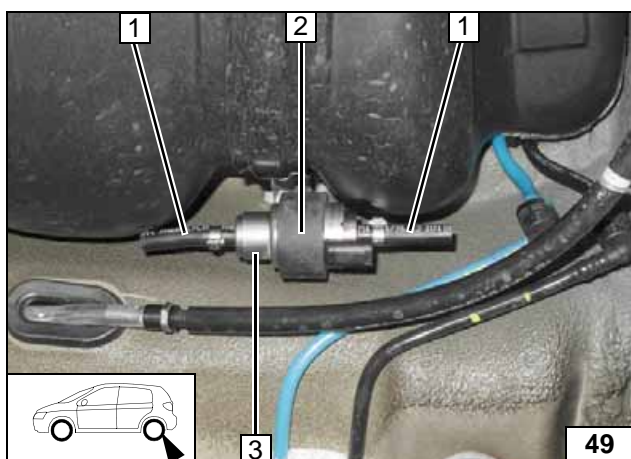

- 1 Hose section, 10 mm dia. clamp [2x]
- 2 Metering pump mount
- 3 Metering pump



Installing metering pump

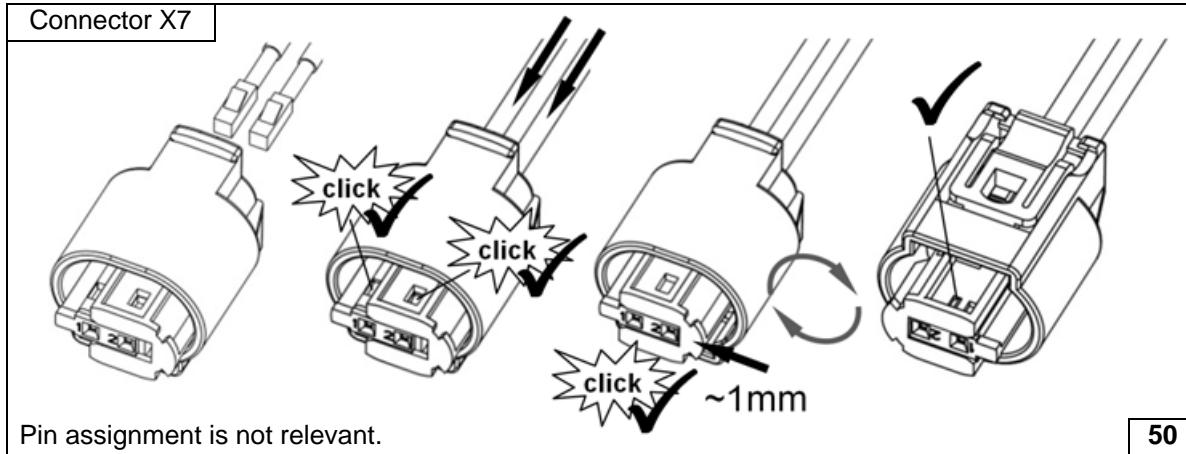
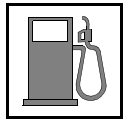

Completing connector of metering pump

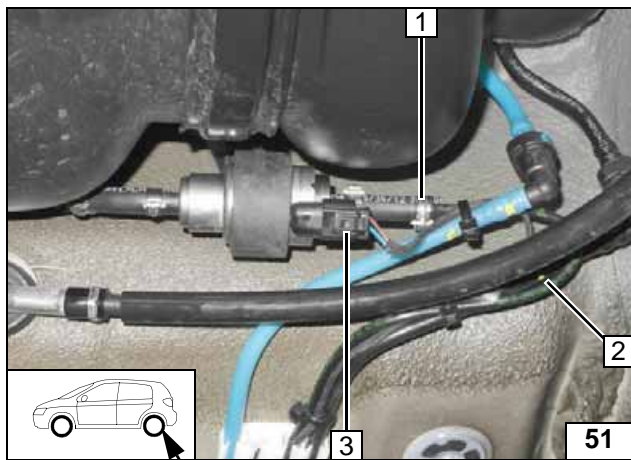

Check the position of the components; adjust if necessary. Check that they have freedom of movement.



- 1 10 mm dia. clamp [2x]
- 2 Fuel line of heater
- 3 Wiring harness of metering pump, connector mounted

Connecting metering pump

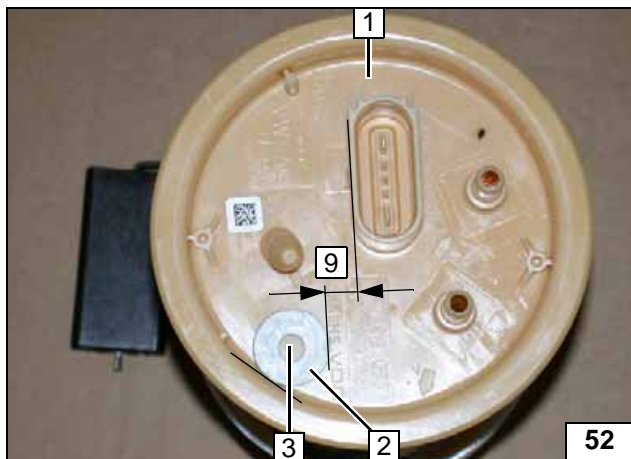

Remove fuel-tank sending unit 1 in accordance with manufacturer's instructions.

- 2 Align washer, outer dia. $d_a = 21.6\text{mm}$
- 3 Copy hole pattern, 6 mm dia. hole



Fuel extraction

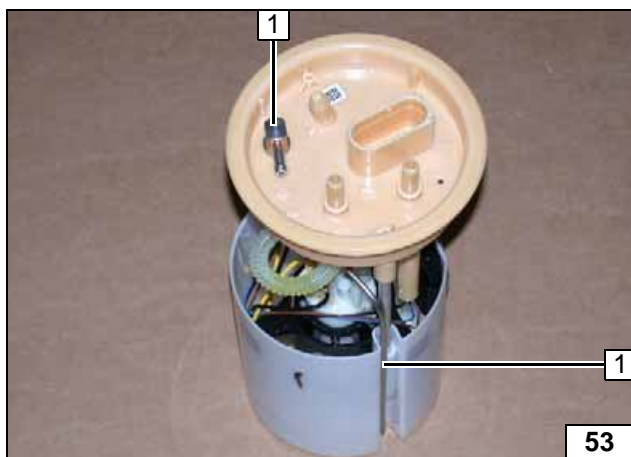

Shape fuel standpipe 1 according to template, cut to length and install.



Installing fuel standpipe

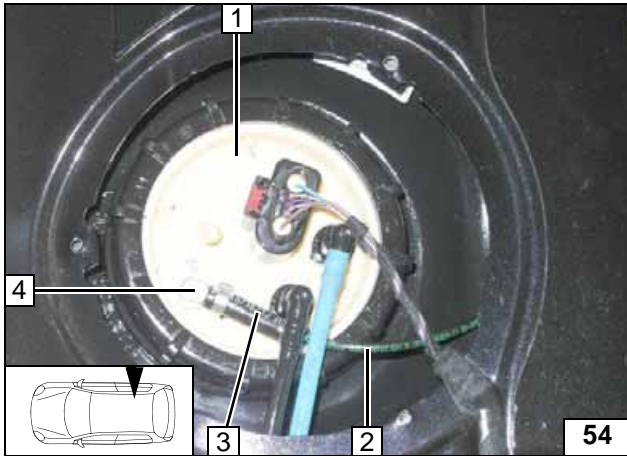
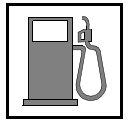

Install fuel-tank sending unit **1** in accordance with manufacturer's instructions.



- 2** Fuel line
- 3** Hose section, 10 mm dia. clamp [2x]
- 4** Fuel standpipe

**Connect-
ing fuel line**

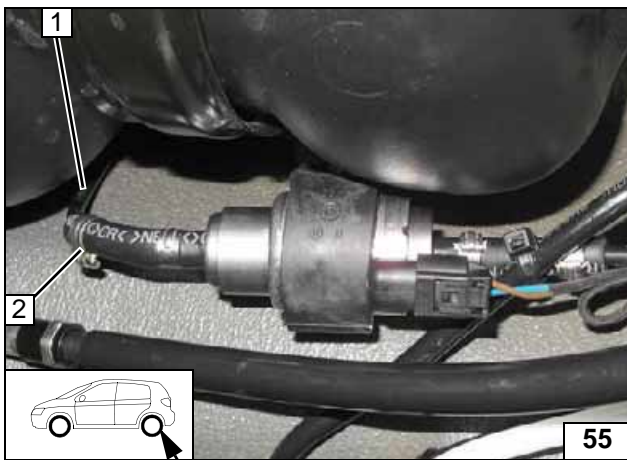

Check the position of the components; adjust if necessary. Check that they have freedom of movement.



- 1** fuel line, fuel standpipe
- 2** 10 mm dia. clamp [2x]

**Connect-
ing meter-
ing pump**

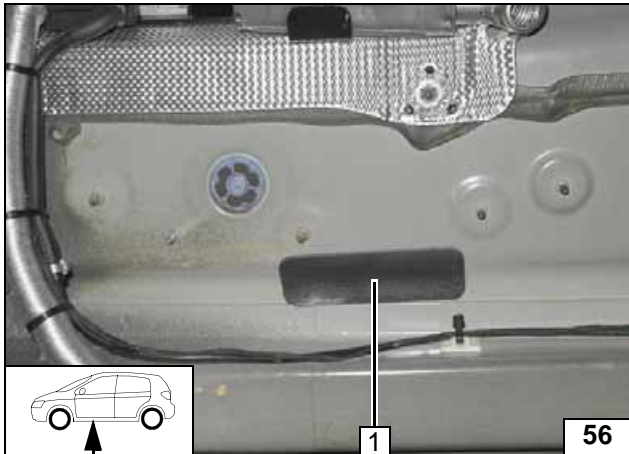
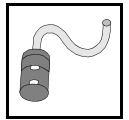

Combustion Air

- 1 Insulation strip



Gluing on
insulation
strip

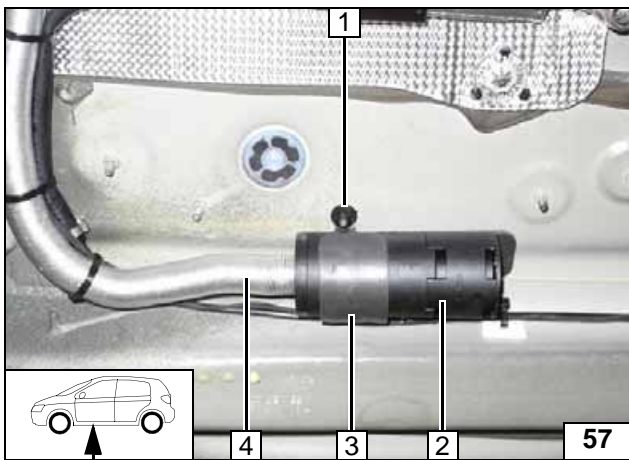

Glue on insulation strips **3** as shown.

- 1 Original vehicle stud bolt, 51mm dia. p-clamp, plastic nut
- 2 Silencer
- 4 Fuel line



Installing
silencer





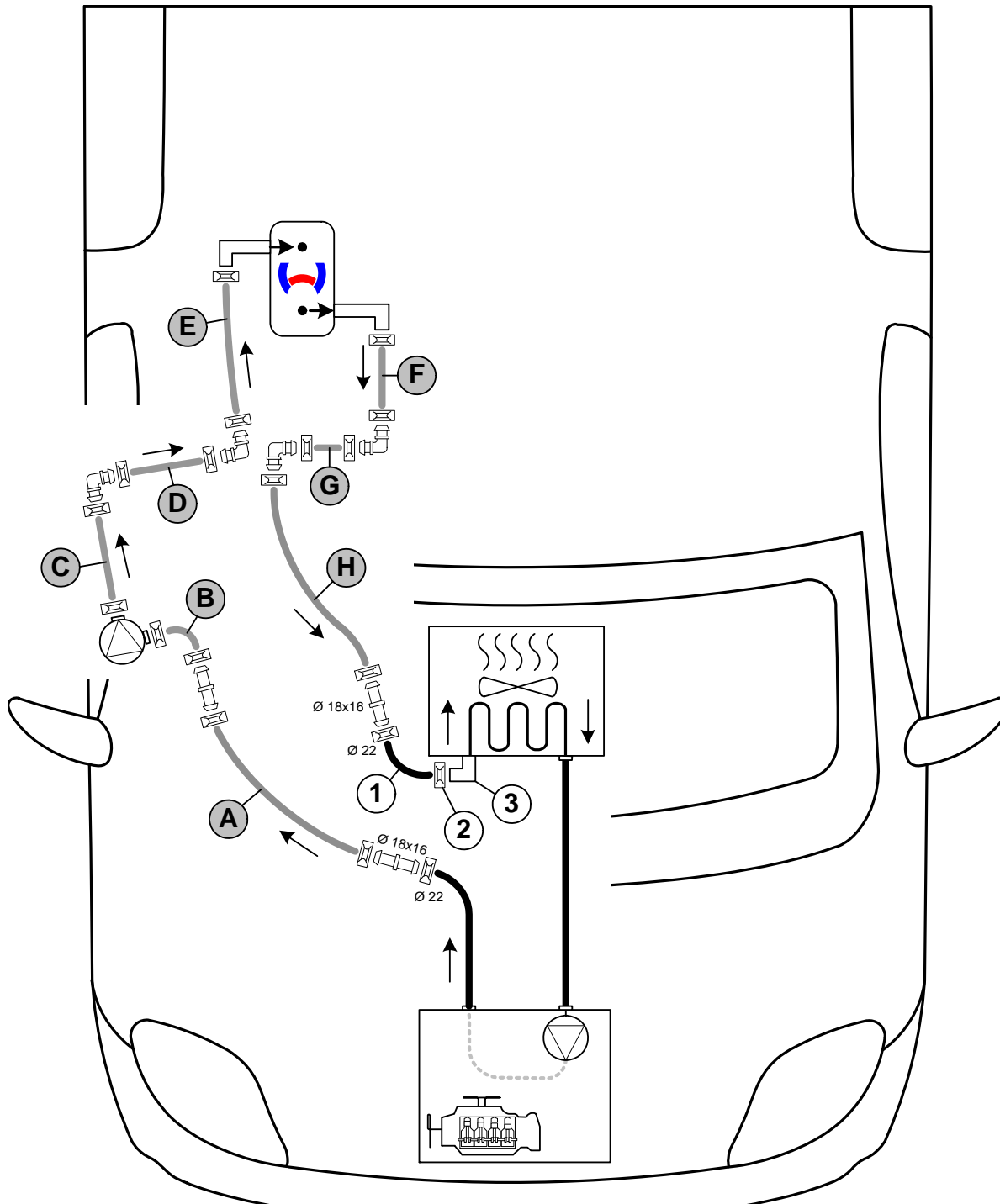

Coolant Circuit

WARNING!

Any coolant running off should be collected using an appropriate container. Install hoses so that they are kink-free. Unless specified otherwise, always fasten using cable ties. Position clamps so that no other hose can be damaged! When installing the hoses, the heater must be filled with coolant. The connection should be modelled on an "inline" circuit and based on the following diagram:



Hose routing diagram

All spring clips without a specific designation  = 25 mm dia. **1** = Original vehicle hose section. **2** = Original vehicle spring clip . **3** = original vehicle quick-release coupling!
 All connecting pipes without a specific designation  and  = 18x18mm dia.



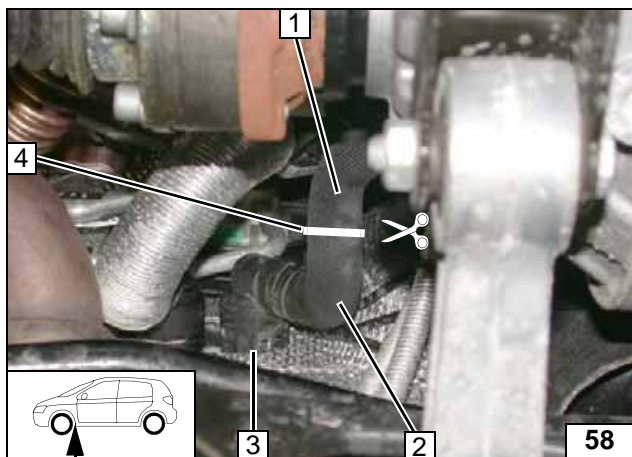

Detach original vehicle quick-release coupling **3** at connection piece.

- 1 Engine outlet hose section
- 2 Hose section of heat exchanger inlet
- 4 Cutting point



Cutting point

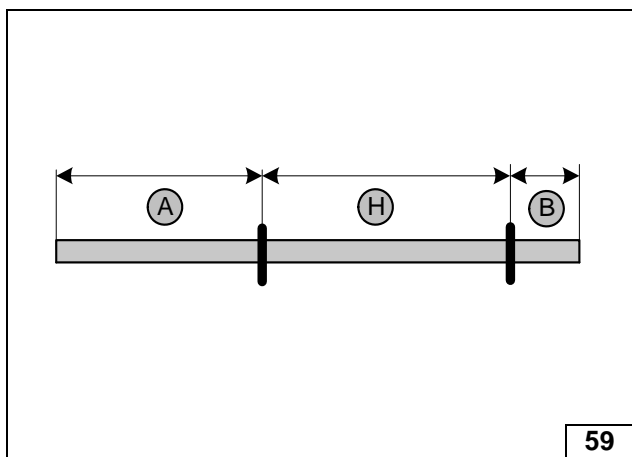

Discard section X.

- A = 350
- B = 50
- H = 400



Cutting heat protection hose to length

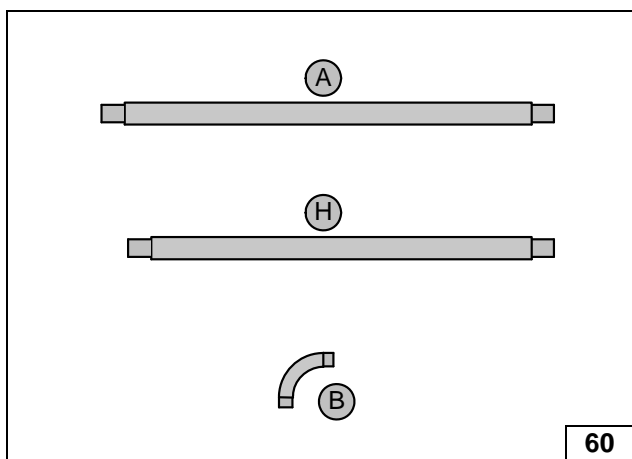

Sliding on heat protection hoses

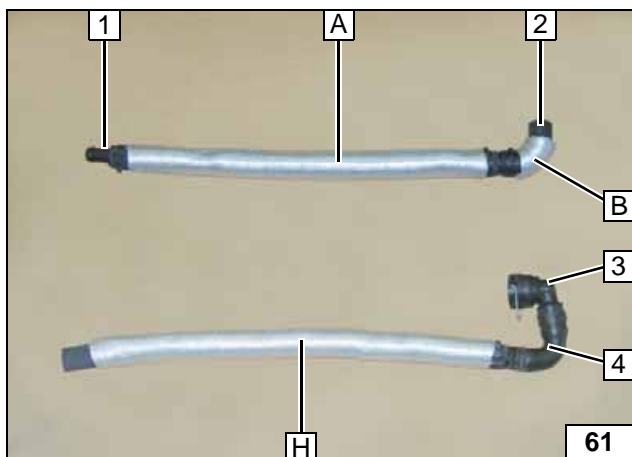

Install original vehicle hose section **4** as shown on original vehicle quick-release coupling **3**.

- 1 Connection of engine outlet
- 2 Connection of circulating pump



Preparing hoses

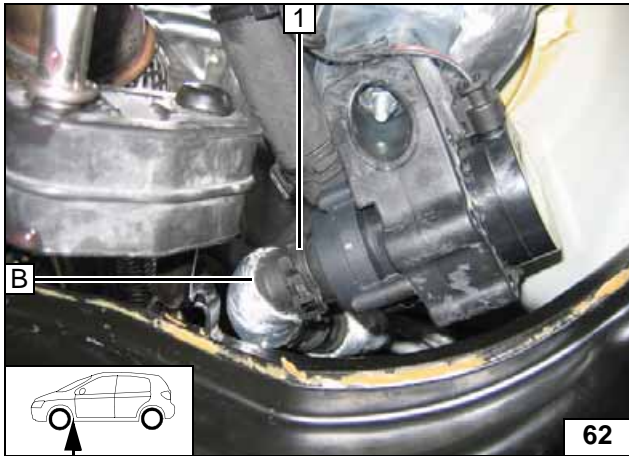

1 Circulating pump

Connect-
ing heater

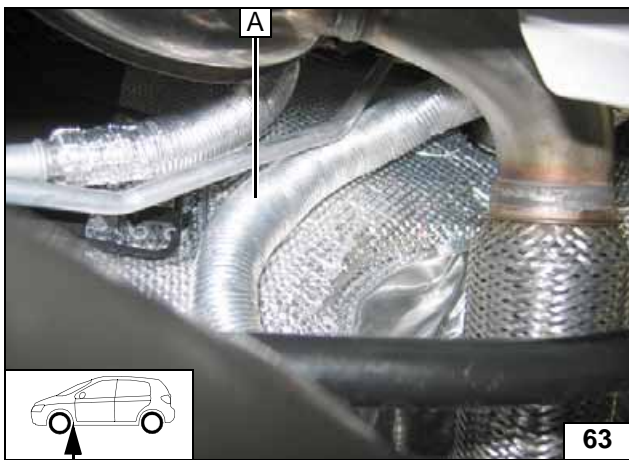

1 Black (sw) rubber isolator

Routing in
engine
compartment

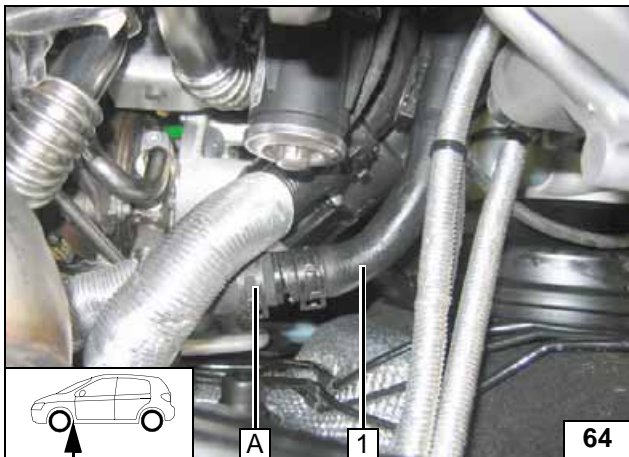

1 Engine outlet hose section

Connect-
ing engine
outlet

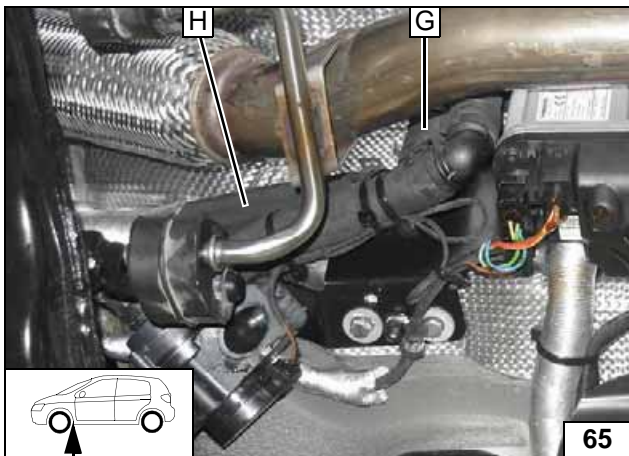

Connect-
ing heater

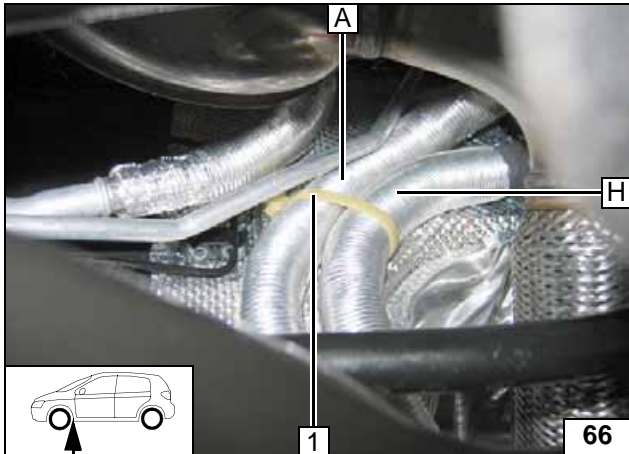

Ensure sufficient distance from neighbouring components.

- 1 Cable tie (temperature resistant)

Routing in engine compartment

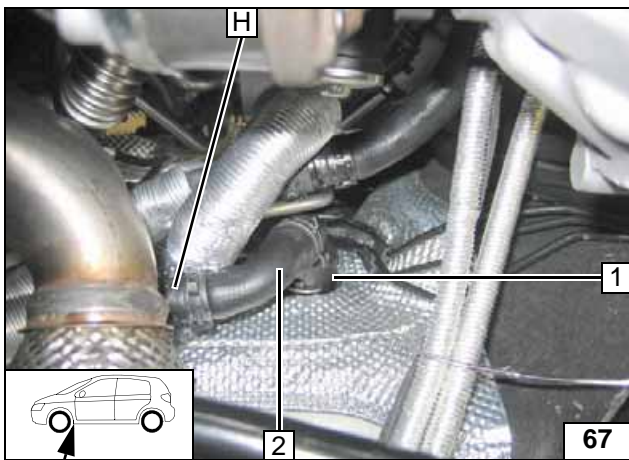

- 1 Original vehicle quick-release coupling at heat exchanger inlet
- 2 Original vehicle hose section.

**Connect-
ing heat ex-
changer
inlet**

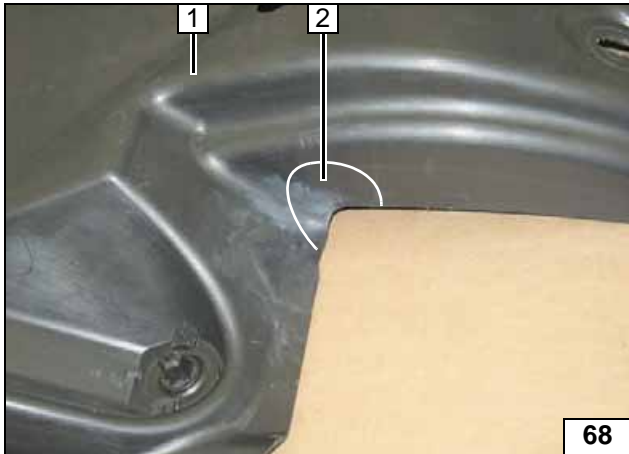

Underbody Trim

- 1 Underbody trim
- 2 Discard section

Cutting out underbody trim

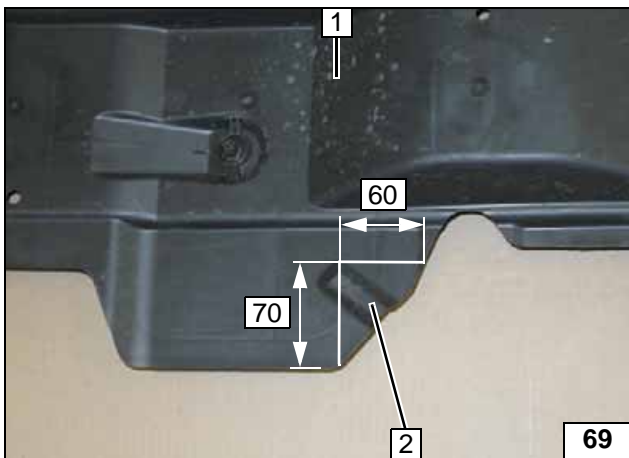

- 1 Underbody trim
- 2 Discard section

Cutting out underbody trim



Ensure sufficient distance from neighbouring components.

- 1 Underbody trim



Mounting underbody trim

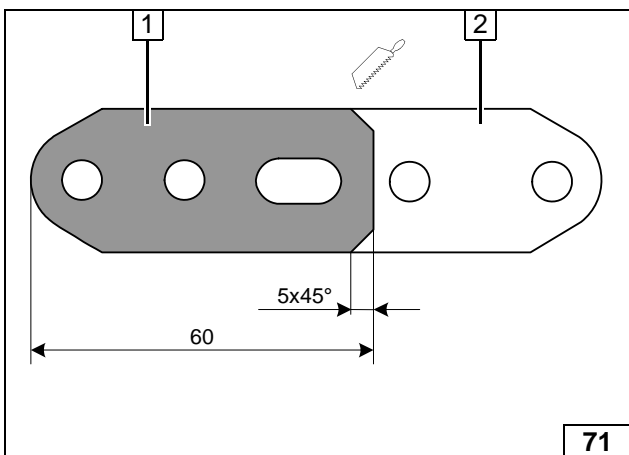

- 1 Perforated bracket
- 2 Discard section



Preparing perforated bracket

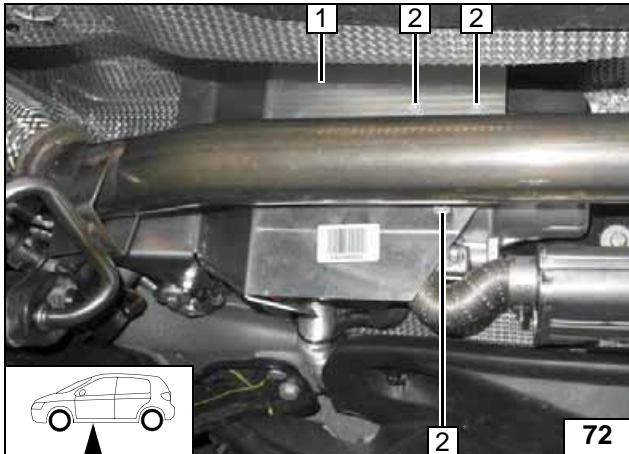

Guard Plate

Prior to installation, adjust guard plate 1 to heater, mind hole coverage, correct if necessary.

- 2 5x13 self-tapping bolt [3x]



Installing guard plate

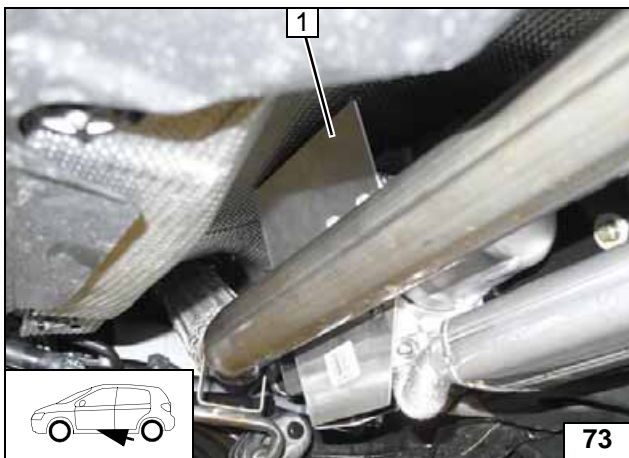

Align guard plate 1 so that there is a maximum distance between the plate and the exhaust pipe.



Aligning heater

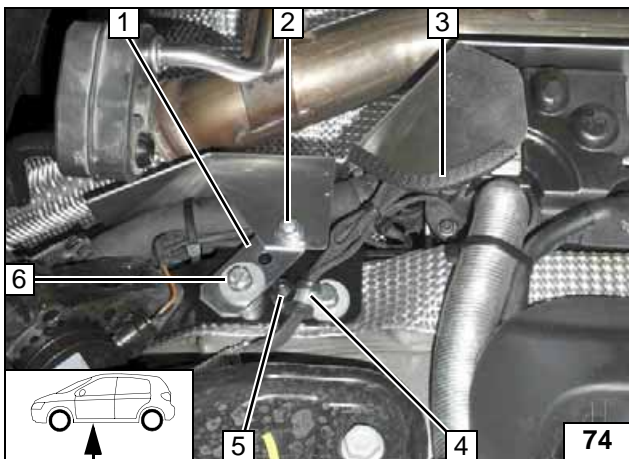

Remove M6x30 bolt at position 6 . Insert 10mm shim between bracket of heater and perforated bracket 1.

- 2 M6x12 bolt, flanged nut
- 3 100 mm edge protection
- 4 8mm dia. rubber-coated p-clamp
- 5 Plastic nut, original vehicle stud bolt
- 6 M6x30 bolt, spring lockwasher, large diameter washer, 10mm shim



Installing guard plate



Final Work

WARNING!

Reassemble the disassembled components in reverse order. Check all hoses, clamps and all electrical connections for firm seating. Insulate all loose wires and tie back.
Only use manufacturer-approved coolant. Spray heater components with anti-corrosion wax (Tectyl 100K, Order No. 111329).



- **Connect the battery.**
- **Fill and bleed the coolant circuit according to the vehicle manufacturer's specifications.**
- **Adjust digital timer, teach Telestart transmitter.**
- **Make settings on A/C control panel according to the "Operating Instructions for End Customer".**
- **Place caution label "Switch off parking heater before refuelling" in the area of the filler neck**
- **For initial start-up and function test, refer to installation instructions**



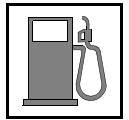

Template for Fuel Standpipe

Top view

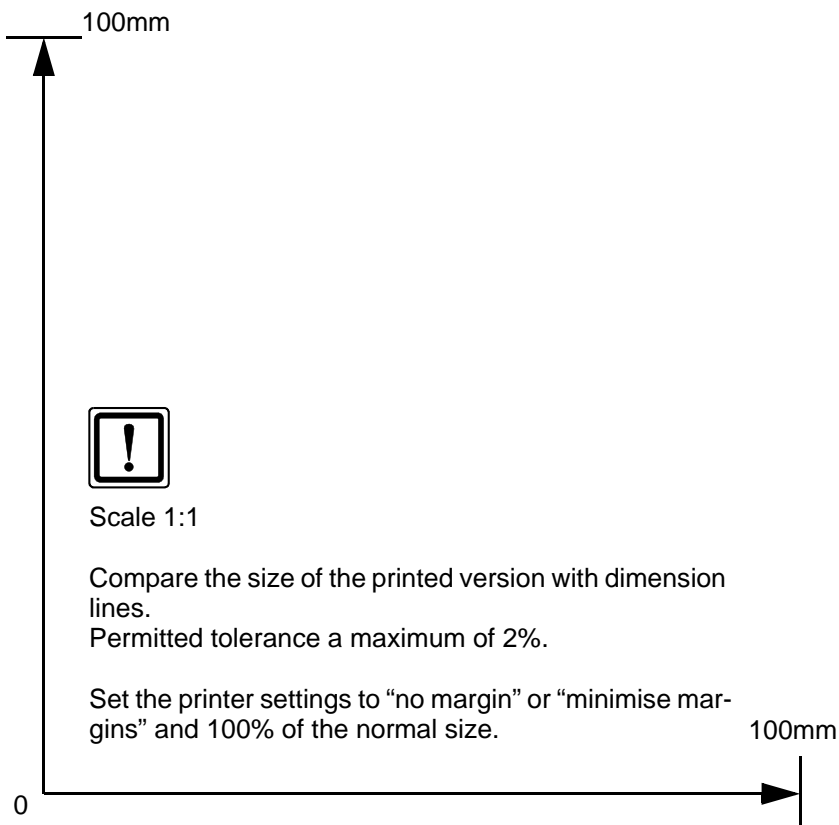
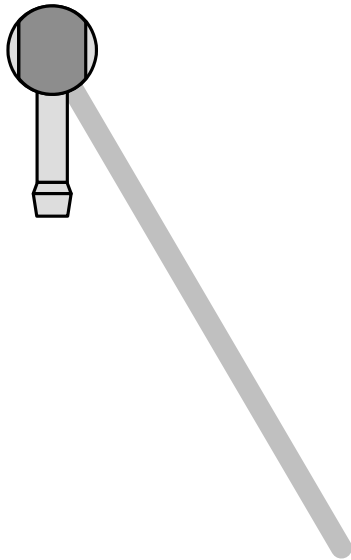

Operating Instructions for Manual Air-Conditioning

Please remove page and add to the vehicle operating instructions.

Note:

We recommend matching the heating time to the driving time.
Heating time = driving time

Example:

For a driving time of approx. 20 min. (in one direction), we recommend not exceeding a switch-on time of 20 min.

Passenger compartment monitoring, if installed, must be deactivated in addition to the vehicle settings for the heating operation.

For information on deactivation, please see the vehicle owner's manual.

Before parking the vehicle, make the following settings:

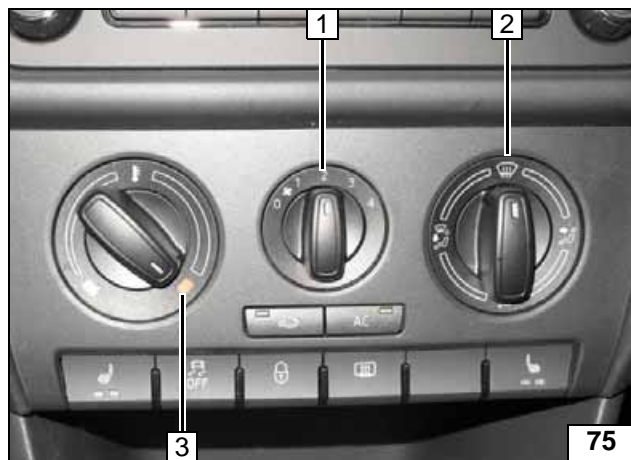

- 1 Set fan to level "1", max. "2"
- 2 Direct air outlet towards windscreen
- 3 Set temperature to "max."



A/C control panel

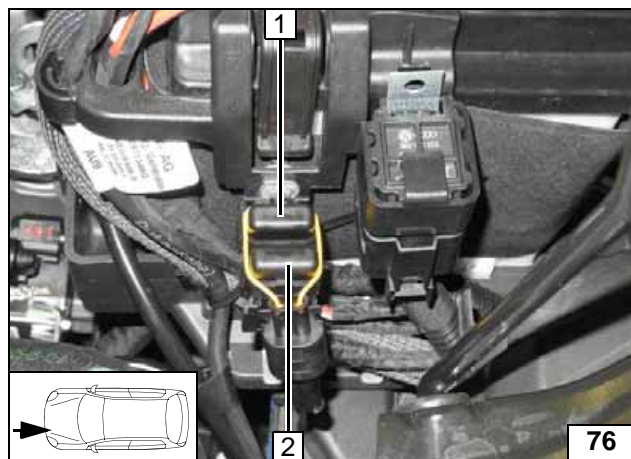

- 1 30A main fuse F2 of passenger compartment
- 2 20A heater fuse F1

Engine compartment fuses

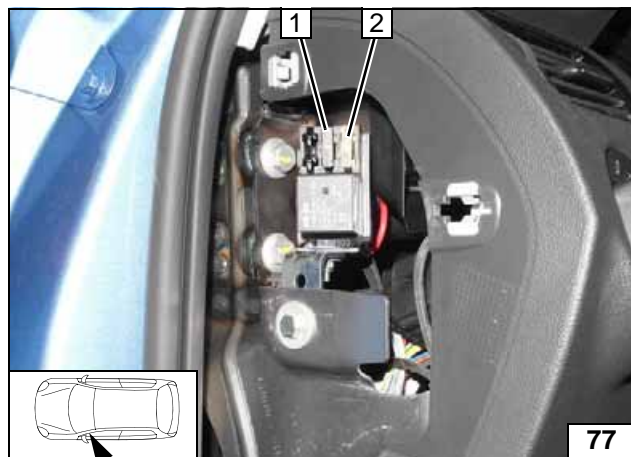

- 1 1A fuse F3 of heater control
- 2 25A fan fuse F4

Passenger compartment fuses



Operating Instructions for Automatic Air-Conditioning

Please remove page and add to the vehicle operating instructions.

Note:

We recommend matching the heating time to the driving time.
 Heating time = driving time

Example:

For a driving time of approx. 20 min. (in one direction), we recommend not exceeding a switch-on time of 20 min.

Passenger compartment monitoring, if installed, must be deactivated in addition to the vehicle settings for the heating operation.

For information on deactivation, please see the vehicle owner's manual.

Before parking the vehicle, make the following settings:

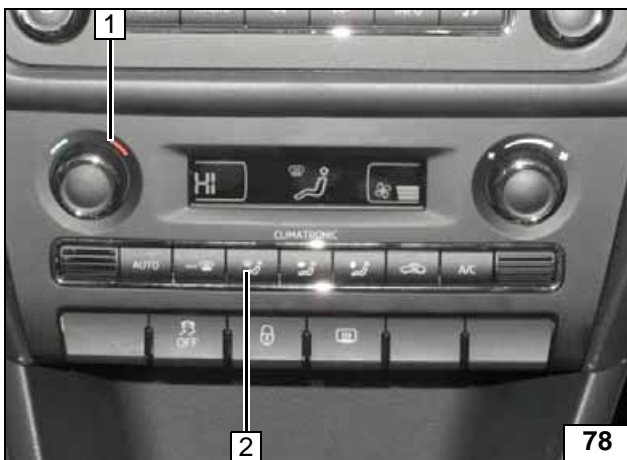

- 1 Set temperature to "HI"
- 2 Direct air outlet towards windscreen

A/C control panel

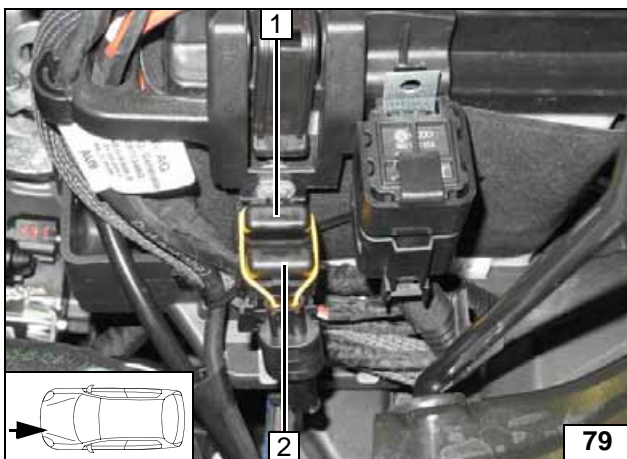

- 1 30A main fuse F2 of passenger compartment
- 2 20A heater fuse F1

Engine compartment fuses

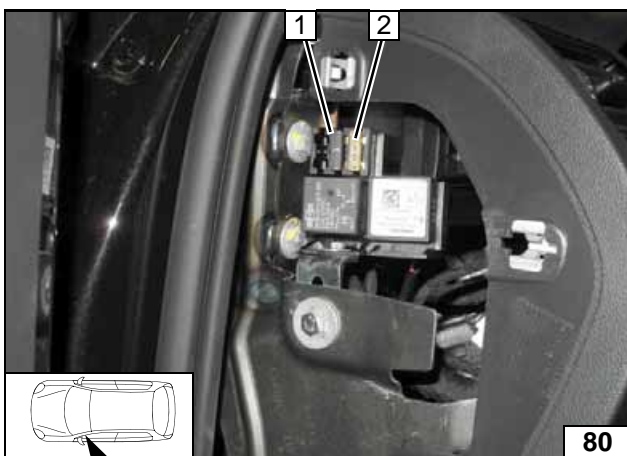

- 1 1A fuse F3 of heater control
- 2 25A fan fuse F4

Passenger compartment fuses