

Water Heater

Thermo Top Evo 4 Parking Heater



Installation Documentation

Fiat 500L

Validity

| Manufacturer | Model | Type | EG-BE No./ ABE |
|--------------|-------|------|-----------------------------|
| Fiat | 500L | 312 | e3 * 2001 / 116 * 0217 *... |
| Fiat | 500L | 312 | e3 * 2001 / 116 * 0217 *... |

| Motorisation | Fuel | Transmission type | Output in kW | Displacement in cm ³ | Engine code |
|--------------|--------|-------------------|--------------|---------------------------------|-------------|
| 0.9 P | Petrol | SG | 77 | 875 | 199B6000 |
| 1.4 P | Petrol | SG | 70 | 1368 | 843A1000 |

SG = manual transmission

From Model Year 2013

Left-hand drive vehicle

Verified equipment variants: Manual / automatic air-conditioning system
 Front fog light / daytime running lights
 Start / Stop
 Headlight washer system

Not verified: Passenger compartment monitoring

Total installation time: approx. 7.5 hours

Fiat 500L

Table of Contents

| | | | |
|--|----|---|----|
| Validity | 1 | Preparing Installation Location | 17 |
| Necessary Components | 2 | Preparing Heater | 18 |
| Installation Overview | 2 | Installing Heater | 19 |
| Information on Total Installation Time | 2 | Coolant Circuit | 20 |
| Information on Operating and Installation Instructions | 3 | Fuel | 25 |
| Information on Validity | 4 | Combustion Air | 30 |
| Technical Information | 4 | Exhaust Gas | 31 |
| Explanatory Notes on Document | 4 | Final Work | 33 |
| Preliminary Work | 5 | Template for Fuel Standpipe | 34 |
| Heater Installation Location | 5 | Operating Instructions for Manual Air-Conditioning | 35 |
| Preparing Electrical System | 6 | Operating Instructions for Automatic Air-Conditioning | 36 |
| Electrical System | 9 | | |
| Fan Controller for Manual Air-Conditioning | 10 | | |
| Fan Controller for Automatic Air-Conditioning | 12 | | |
| MultiControl CAR Option | 15 | | |
| Remote Option (Telestart) | 15 | | |
| Remote Option (Thermo Call) | 16 | | |

Necessary Components

- Basic delivery scope of *Thermo Top Evo 4* based on price list
- Installation kit for Fiat 500L 2013 Petrol: **1320779D**
- Required additionally for automatic air-conditioning: Automatic A/C kit: **1320864B**
- Heater control in accordance with price list and upon consultation with end customer
- In case of Telestart, indicator lamp in accordance with price list and in consultation with end customer

Installation instructions:

- Arrange for the vehicle to be delivered with the tank only about ¼ full.
- The installation location of the push button for Telestart or Thermo Call must be agreed with the end customer.
- Depending on the available space and manufacturer's instructions, we recommend the use of a vehicle battery with more electrical capacity.
- When installing a parking heater only the Thermo Top Evo 4 should be built in.
The heater will be integrated into the "island" coolant circuit and is used to heat up the passenger compartment. The engine is not pre-heated.

Installation Overview

Legend:

1. Heater
2. Engine compartment fuse holder
3. Passenger compartment relay and fuse holder
4. PWM GW (only in case of automatic air-conditioning)
5. Circulating pump
6. MultiControl CAR
7. Metering pump

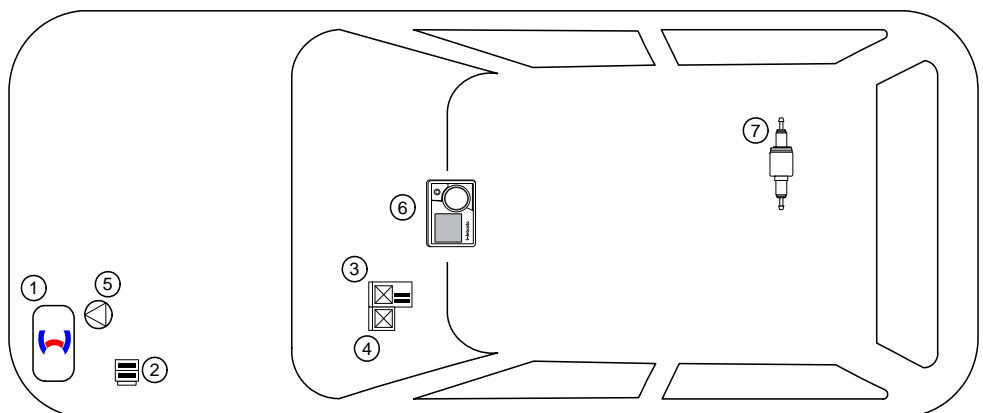

Information on Total Installation Time

The total installation time includes the time needed for mounting and demounting of the vehicle-specific components, the heater specific installation time and all other times required for the system integration and initial start-up of the heater.

The total installation time may vary for vehicle equipment other than provided.

Information on Operating and Installation Instructions

1 Important notes (not complete)

1.1 Installation and Repair



The improper installation or repairing of Webasto heating and cooling systems can cause fire or the leakage of deadly carbon monoxide, leading to serious injury or death.



To install and repair Webasto heating and cooling systems you need to have completed a special company training course and have the appropriate technical documentation, special tools and special equipment.



Installation and repair may ONLY be carried out by persons trained and certified in a Webasto training course. NEVER try to install or repair Webasto heating or cooling systems if you have not completed a Webasto training course, you do not have the necessary technical skills and you do not have the technical documentation, tools and equipment available to ensure that you can complete the installation and repair work properly.

Only use genuine Webasto parts. See the Webasto air and water heaters accessories catalogue for this purpose.

1.2 Operation

To ensure safe operation, we recommend having the heater checked every two years by an authorised Webasto dealer, especially when used over a long period and/or under extreme environmental conditions.

Do not operate the heater in closed rooms due to the danger of poisoning and suffocation.

Always switch off the heater before refuelling.

The heater may only be used with the prescribed fuel diesel (DIN EN 590) or petrol (DIN EN 228).

The heater may not be cleaned with a high-pressure cleaner.

1.3 Please note

ALWAYS follow all Webasto installation and operating instructions and observe all warnings.

To become familiar with and understand all functions and properties of the heater, the operating instructions must be read carefully and observed at all times.

For proper, safe installation and repair work, the installation instructions with all warnings and safety information must be carefully read and observed at all times. Please always contact a workshop authorised by Webasto for all installation and repair work.

Important

Webasto shall assume no liability for defects, damage and injuries resulting from a failure to observe the installation, repair and operating instructions of the information contained in them.

This liability exclusion particularly applies to improper installations and repairs, installations and repairs by untrained persons or in the case of a failure to use genuine spare parts.

The liability due to culpable disregard to life, limb or health and due to damage or injuries caused by a wilful or reckless breach of duty remain unaffected, as does the obligatory product liability.

Installation should be carried out according to the general, standard rules of technology. Unless specified otherwise, fasten hoses, lines and wiring harnesses to original vehicle lines and wiring harnesses using cable ties. Insulate loose wire ends and tie back. Connectors on electronic components must audibly snap into place during assembly.

Sharp edges should be fitted with rub protection. Spray unfinished body areas, e.g. drilled holes, with anti-corrosion wax (Tectyl 100K, Order No. 111329).

Observe the instructions and guidelines of the respective vehicle manufacturer for demounting and mounting vehicle specific components!

The initial startup is to be executed with the Webasto Thermo Test Diagnosis.

When installing a programmable control module (e.g. a PWM Gateway), the corresponding settings must be checked or adjusted.

2 Statutory regulations governing installation

| Guidelines | TT-Evo |
|----------------------------|------------|
| Heating Directive ECE R122 | E1 00 0258 |
| EMC Directive ECE R10 | E1 04 5627 |

Note

The regulations of these guidelines are binding in the scope of the Directive 70/156/EEC and/or 2007/46/EC (for new vehicle models from 29/04/2009) and should also be observed in countries in which there are no special regulations.

Important

Failure to follow the installation instructions will result in the invalidation of the type approval for the heater and therefore invalidation of the general **homologation of the vehicle**.

Note

The heater is licensed in accordance with paragraph 19, section 3, No. 2b of the StVZO (German Road Traffic Licensing Authority).

2.1 Excerpt from the directive 122 (heater) section 5 for the installation of the heater.

Beginning of excerpt.

ANNEX VII

REQUIREMENTS FOR COMBUSTION HEATERS AND THEIR INSTALLATION

1. GENERAL REQUIREMENTS

1.7.1. A clearly visible tell-tale in the operator's field of view shall inform when the combustion heater is switched on or off.

2. VEHICLE INSTALLATION REQUIREMENTS

2.1. Scope

2.1.1. Subject to paragraph 2.1.2. combustion heaters shall be installed according to the requirements of this Annex.

2.1.2. Vehicles of category O having liquid fuel heaters are deemed to comply with the requirements of this Annex.

2.2. Positioning of heater

2.2.1. Body sections and any other components in the vicinity of the heater must be protected from excessive heat and the possibility of fuel or oil contamination.

2.2.2. The combustion heater shall not constitute a risk of fire, even in the case of overheating. This requirement shall be deemed to be fulfilled if the installation ensures an adequate distance to all parts and suitable ventilation, by the use of fire resistant materials or by the use of heat shields.

2.2.3. In the case of M2 and M3 vehicles, the heater must not be positioned in the passenger compartment. However, an installation in an effectively sealed envelope which also complies with the conditions in paragraph 2.2.2 may be used.

2.2.4. The label referred to in paragraph 1.4 or a duplicate, must be positioned so that it can be easily read when the heater is installed in the vehicle.

2.2.5. Every reasonable precaution should be taken in positioning the heater to minimise the risk of injury and damage to personal property.

2.3. Fuel supply

2.3.1. The fuel filler must not be situated in the passenger compartment and must be provided with an effective cap to prevent fuel spillage

2.3.2. In the case of liquid fuel heaters, where a supply separate to that of the vehicle is provided, the type of fuel and its filler point must be clearly labelled

2.3.3. A notice, indicating that the heater must be shut down before refuelling, must be affixed to the fuelling point. In addition a suitable instruction must be included in the manufacturer's operating manual.

2.4. Exhaust system

2.4.1. The exhaust gas outlet must be located so as to prevent emissions from entering the vehicle through ventilators, heated air inlets or opening windows.

2.5. Combustion air inlet

2.5.1. The air for the combustion chamber of the heater must not be drawn from the passenger compartment of the vehicle.

2.5.2. The air inlet must be so positioned or guarded that blocking by rubbish or luggage is unlikely.

2.6. Heating air inlet

2.6.1. The heating air supply may be fresh or recirculated air and must be drawn from a clean area not likely to be contaminated by exhaust fumes emitted either by the propulsion engine, the combustion heater or any other vehicle source.

2.6.2. The inlet duct must be protected by mesh or other suitable means.

2.7. Heating air outlet

2.7.1. Any ducting used to route the hot air through the vehicle must be so positioned or protected that no injury or damage could be caused if it were to be touched.

2.7.2. The air outlet must be so positioned or guarded that blocking by rubbish or luggage is unlikely.

End of excerpt.

In multilingual versions the German language is binding.

Fiat 500L

Information on Validity

This installation documentation applies to Fiat 500L Petrol vehicles - for validity, see page 1 - from model year 2013 and later, assuming technical modifications to the vehicle do not affect installation, any liability claims excluded. Depending on the vehicle version and equipment, modifications may be necessary during installation with respect to this installation documentation.

Vehicle and engine types, equipment variants and other specifications not listed in this installation documentation have not been tested. However, installation according to this installation documentation may be possible.

Technical Information

Special tools

- Hose clamp pliers for self-clamping hose clamps
- Hose clamp pliers for Clic hose clamps of type W
- Automatic wire stripper 0.2 - 6mm²
- Crimping pliers for cable lug / tab connector 0.5 - 6mm²
- Torque wrench for 2.0 - 10 Nm
- Hose clamping pliers
- Metric thread-setter kit
- 8.5mm spot-weld drill
- Webasto Thermo Test Diagnosis with current software

Dimensions

- All dimensions are in mm















Tightening torque values

- Tightening torque values of 5x13 heater bolts and 5x11 heater stud bolts = 8 Nm.
- Tightening torque values of 5x15 bolts for retaining plate of water connection piece = 7Nm.
- Tighten other bolt connections in accordance with manufacturer's instructions or in accordance with state-of-the-art-technology.

Explanatory Notes on Document

You will find an identification mark on the outside top right corner of the page in question to provide you with a quick overview of the individual working steps.

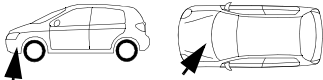
Special features are highlighted using the following symbols:

| | | | |
|--------------------------|---|---|---|
| Mechanical system |  | Specific risk of injury or fatal accidents. |  |
| Electrical System |  | Specific risk due to electrical voltage. |  |
| Coolant circuit |  | Specific risk of damage to components. |  |
| Combustion air |  | Specific risk of fire or explosion. |  |
| Fuel |  | Reference to general installation instructions of the Webasto components or to the manufacturer's vehicle-specific documents |  |
| | | Reference to a special technical feature. |  |
| Exhaust gas |  | The arrow in the vehicle icon indicates the position on the vehicle and the viewing angle |  |
| Software |  | Tightening torque according to the manufacturer's vehicle-specific documents |  |

Fiat 500L

Preliminary Work

Vehicle

- Open the fuel tank cap.
- Ventilate the fuel tank.
- Close the fuel tank cap again.
- Depressurise the cooling system.
- Remove the upper engine cover.
- Disconnect the battery and remove it with the battery carrier.
- Remove the windscreen wiper arms on the left and right.
- Remove the cowl trim.
- Remove the wiper motor with linkage.
- Fold back the backrest of the rear bench seat, completely fold back the bench seat.
- Remove the trim below the bench seat (4x plastic clip).
- Remove the tank-fitting service lid.
- Remove the fuel-tank sending unit in accordance with the manufacturer's instructions.
- Remove the lower engine cover/underride protection.
- Remove the trim of the fuel lines on the underbody.
- Remove the footwell trim below the glove compartment.
- Remove the lateral cover of the centre console.
- Remove the cover of the fan controller in the footwell on the front passenger's side (only in case of automatic air-conditioning).
- Remove the cover/access to the driver's side fuse box.

Heater

- Remove years that do not apply from the type and duplicate label.
- Attach the duplicate label (type label) in the appropriate place in the engine compartment.

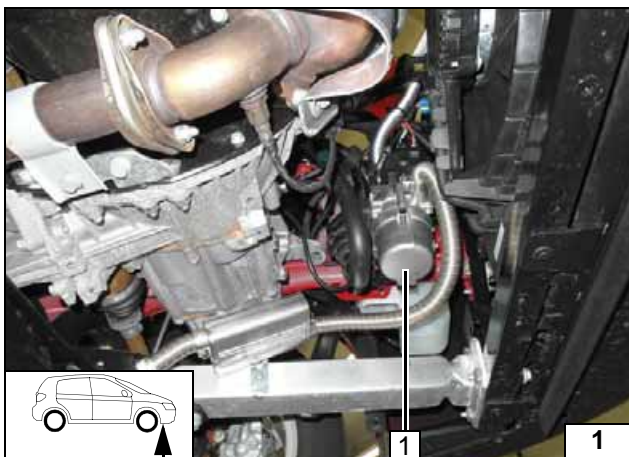

Heater Installation Location

- 1 Heater

Installation location

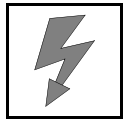

Preparing Electrical System

Wire sections retain their numbering throughout the whole document.

Produce all following electrical connections as shown in the wiring diagram.

Manual air-conditioning

- ① Red (rt) wire of fan wiring harness
- ② Black (sw) wire of fan wiring harness



Assigning wires



Connecting wires to socket of passenger compartment relay and fuse holder



Cutting to length / assigning wires

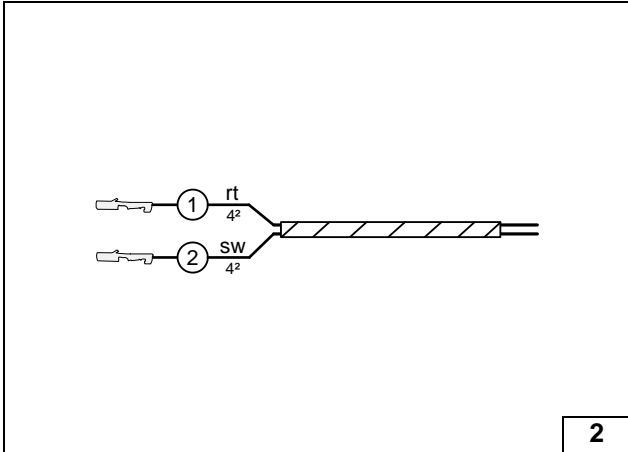

2

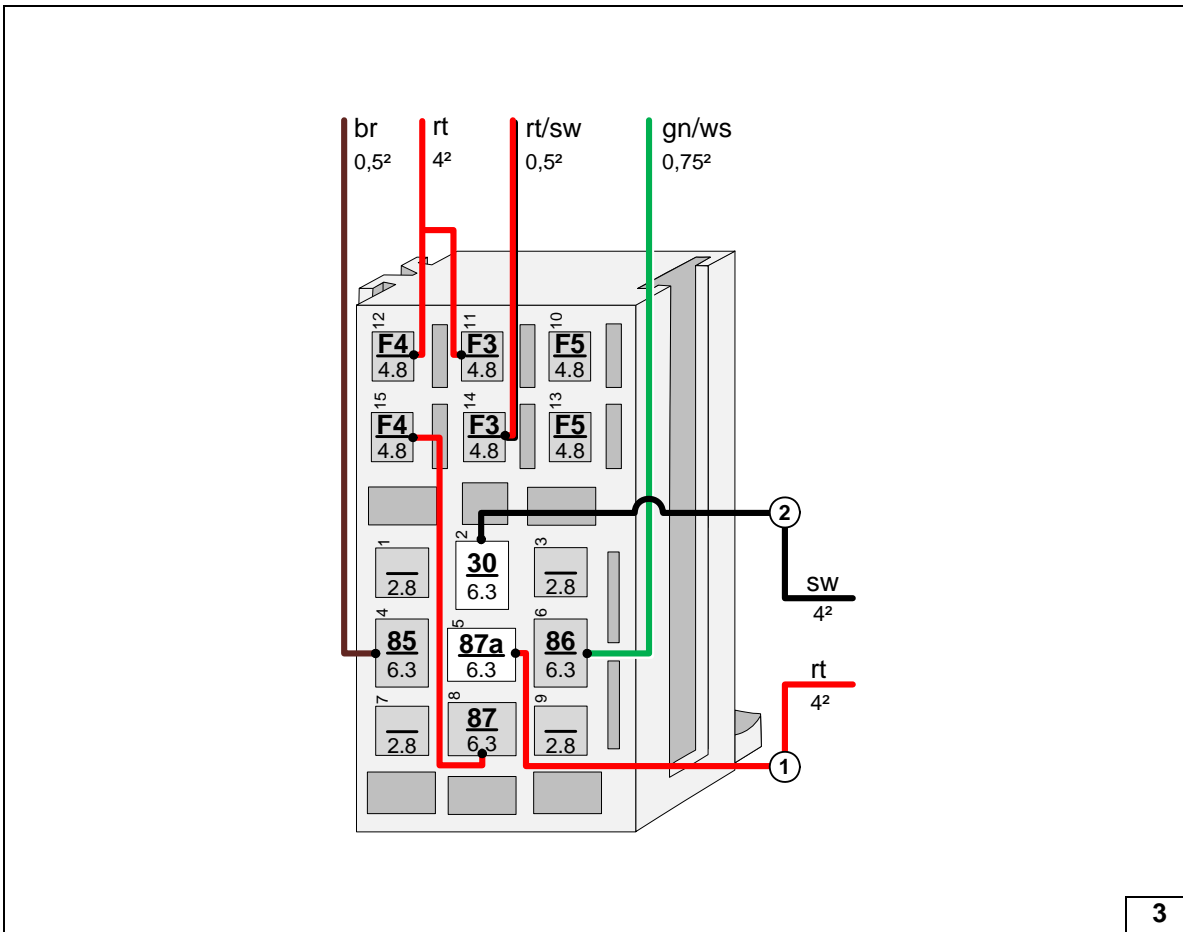

3

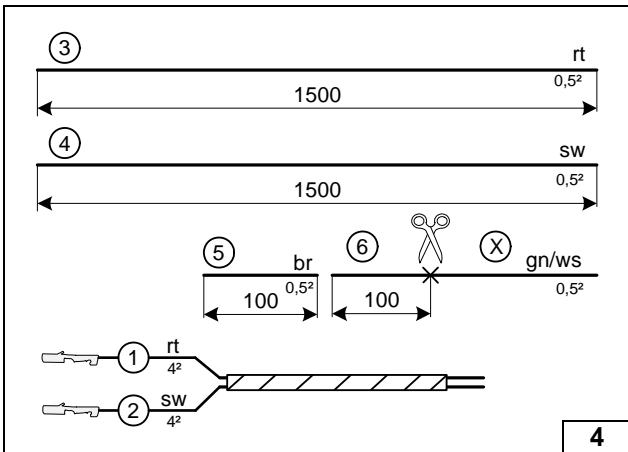

4

Automatic air-conditioning

Discard section X.
Pull wires ③ and ④ into a protective sleeving.

- ① Red (rt) wire of fan wiring harness
- ② Black (sw) wire of fan wiring harness

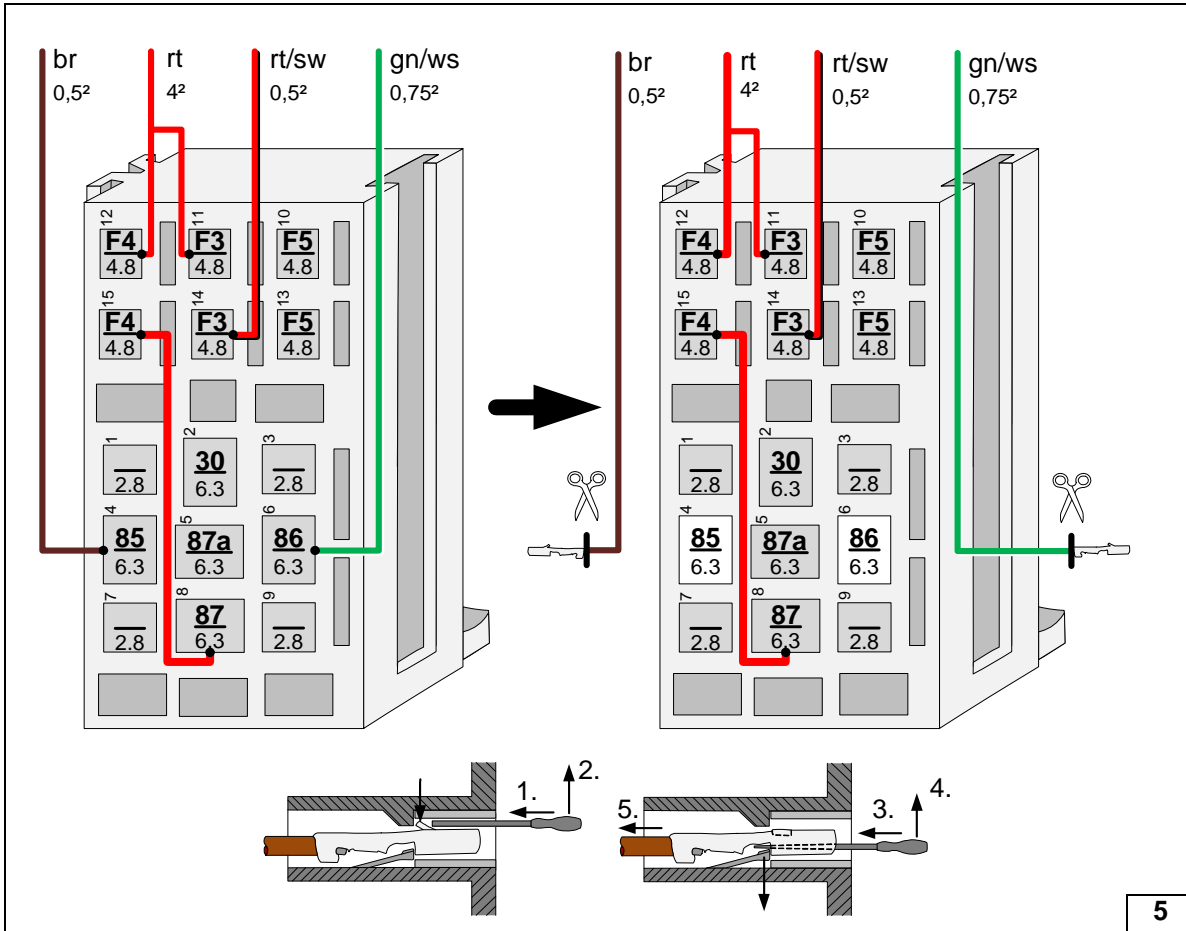
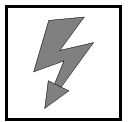

Preparing relay and fuse holder of passenger compartment

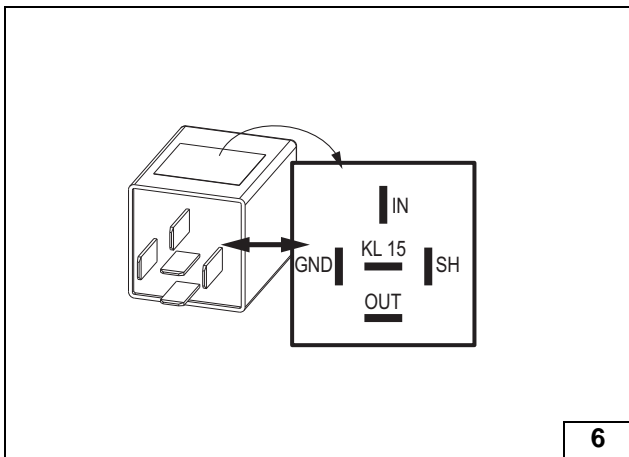

The settings of the PWM Gateway are to be checked before the heater start-up, and adjusted if necessary.



Settings:

- Duty cycle: 25%
- Frequency: 1000Hz
- Voltage: 4.8V
- Function: High side

View of PWM-GW

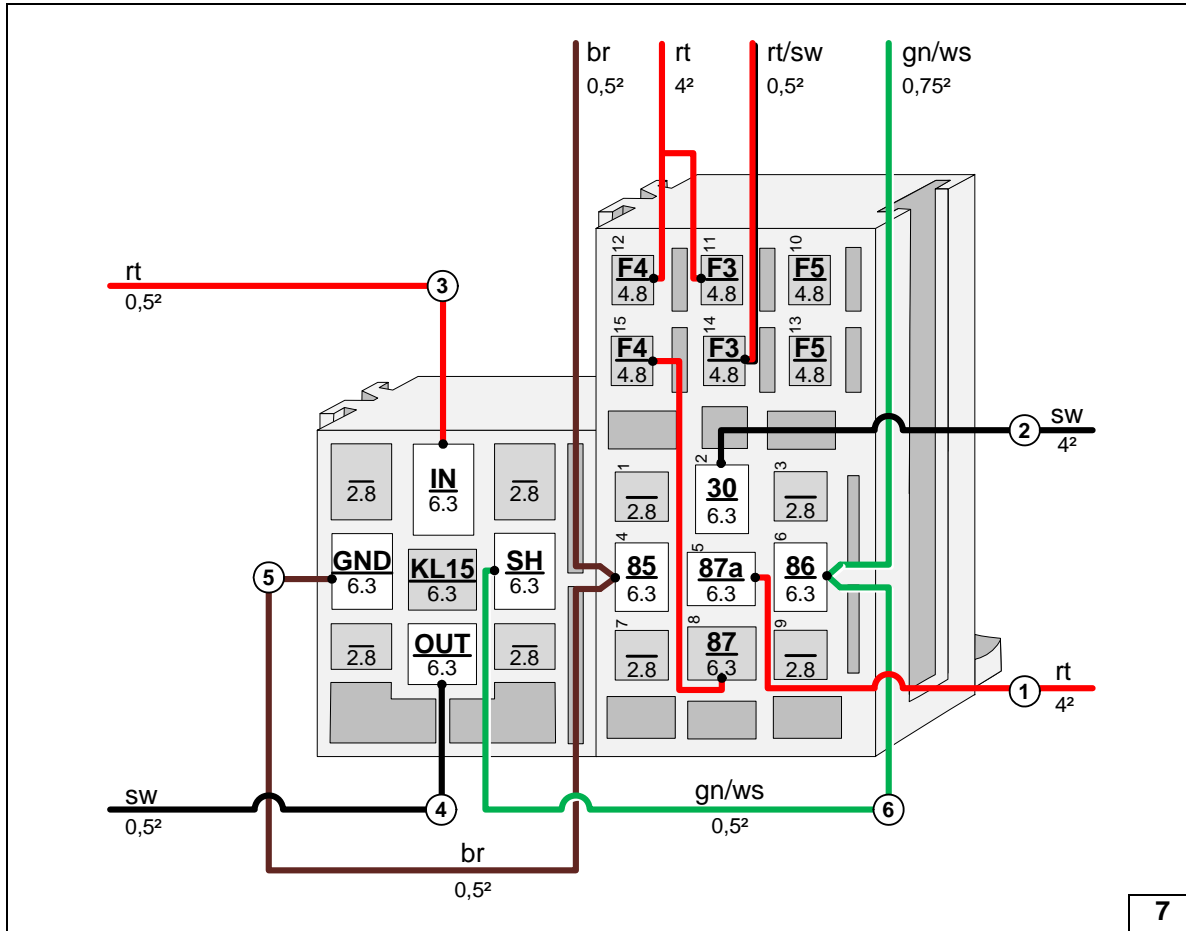
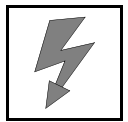

Connecting wires to sockets of PWM GW and passenger compartment relay and fuse holder, interconnecting sockets

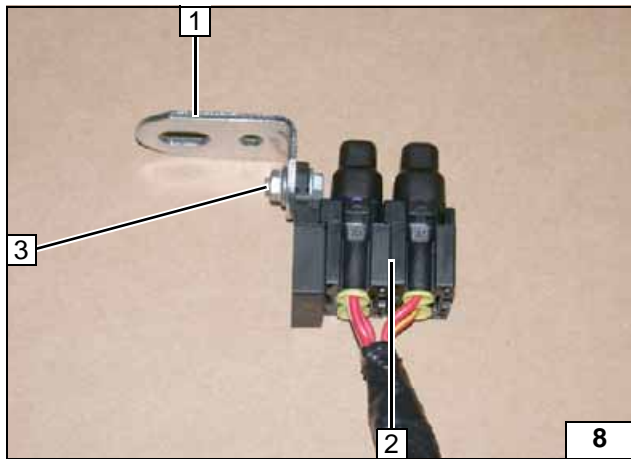

All vehicles

- 1 Angle bracket
- 2 Fuse F1-2
- 3 M5x16 bolt, large diameter washer [2x], nut

Preparing engine compartment fuse holder

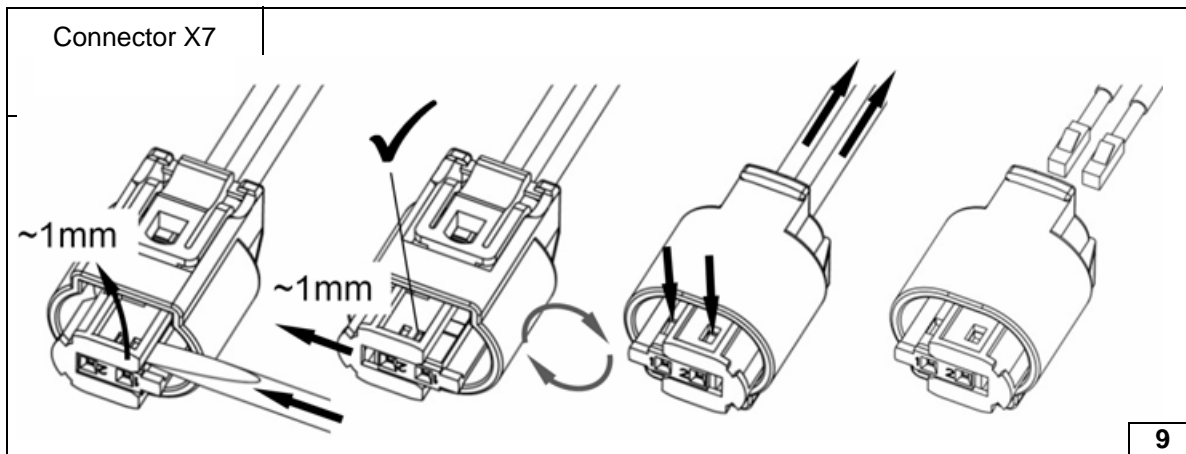

Removing metering pump connector



Electrical System

Wiring harness pass through of the engine compartment

- 1 17mm dia. hole, insert protective rubber plug
- 2 Wiring harness of heater, heater control

Wiring harness pass through of coolant reservoir

- 1 Protective rubber plug inserted (see image on left)
- 2 Wiring harness of heater, heater control
- 3 Original vehicle protective rubber plug
- 4 Cable tie [2x]

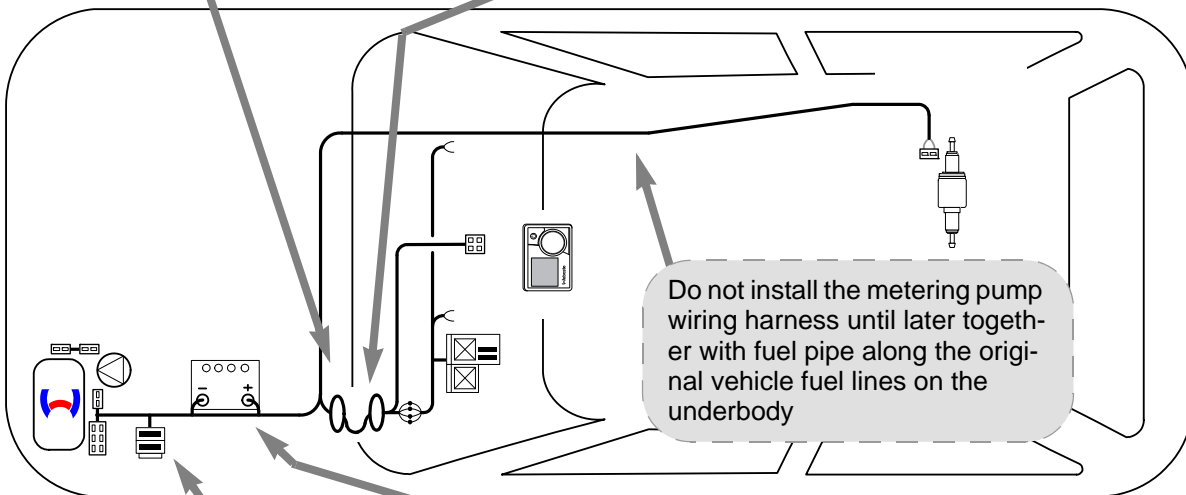
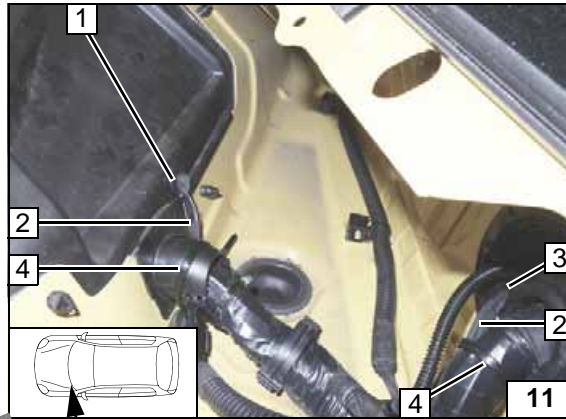
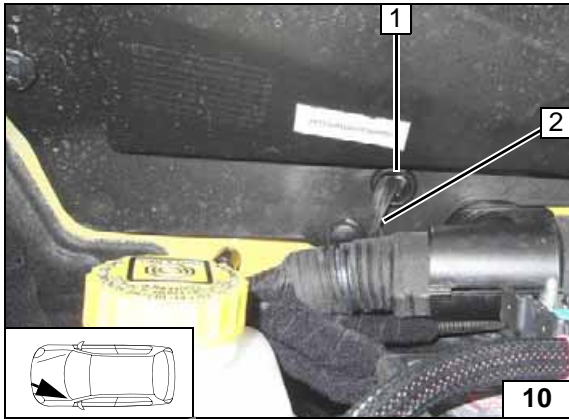

Wiring harness routing diagram

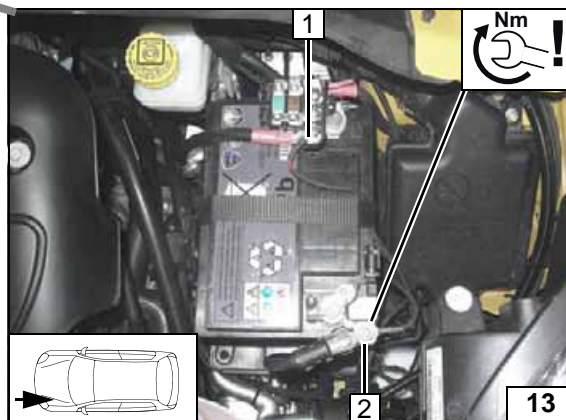
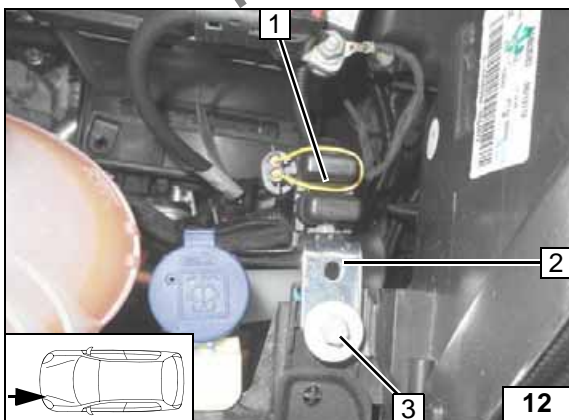

Engine compartment fuse holder

- 1 Fuse F1-2
- 2 Angle bracket
- 3 Original vehicle bolt

Positive and earth wire

- 1 Positive wire on positive battery terminal
- 2 Earth wire on negative battery terminal



Fan Controller for Manual Air-Conditioning

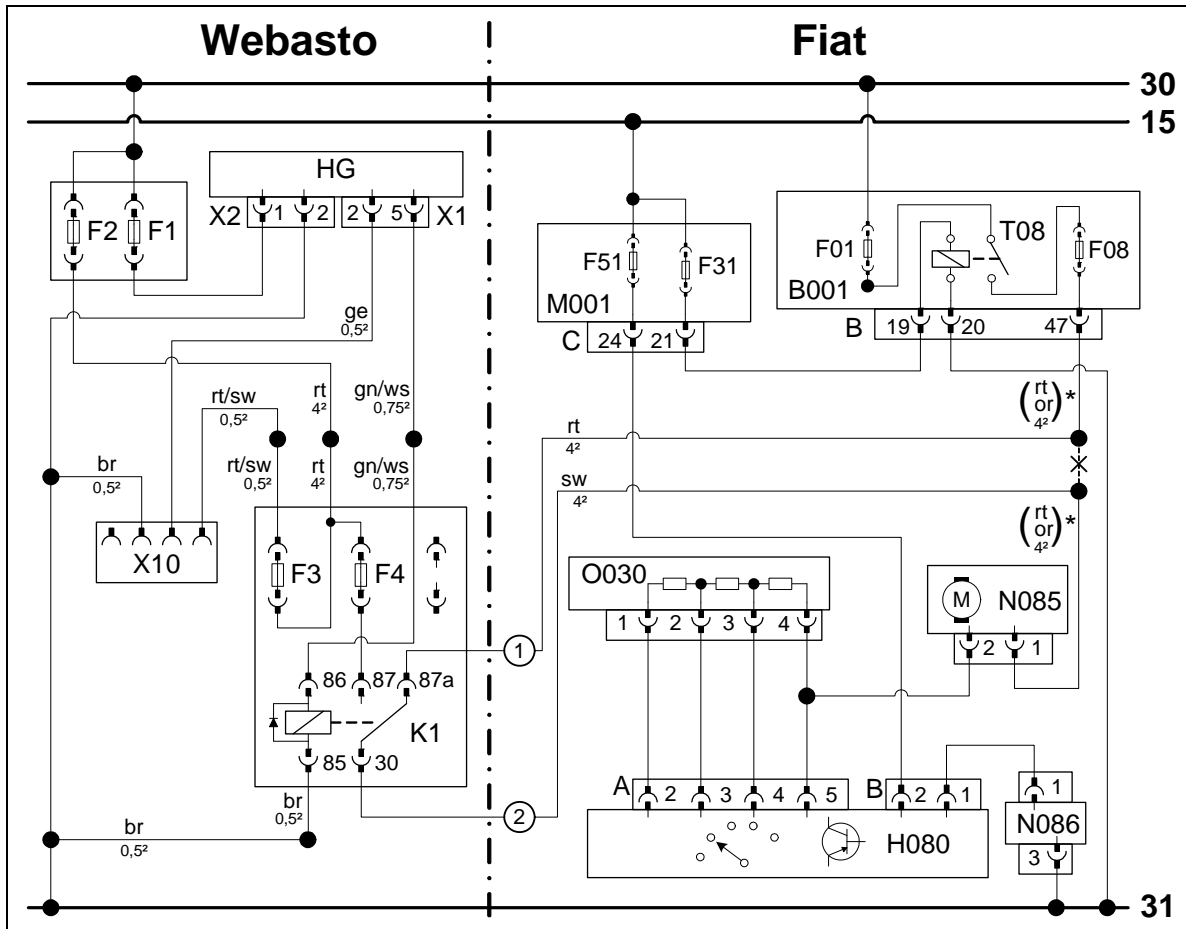

Wiring diagram

| Webasto components | | Vehicle components | | Colours and symbols | |
|--------------------|-----------------------------------|--------------------|--|---------------------|--------------------------|
| HG | TT-Evo Heater | B001 | Central electrical box in engine compartment | rt | red |
| X1 | 6-pin heater connector | F01 | 70A fuse | sw | black |
| X2 | 2-pin heater connector | F08 | 40A fuse | ge | yellow |
| F1 | 20A fuse | T08 | Fan relay | gn | green |
| F2 | 30A fuse | F51 | 5A fuse | br | brown |
| X10 | 4-pin connector of heater control | F31 | 5A fuse | ws | white |
| F3 | 1A fuse | C | Connector M001 | or | orange |
| F4 | 25A fuse | O030 | Resistor group | | |
| K1 | Fan relay | N085 | Fan motor | | |
| | | N086 | Electr. thermostat | | |
| | | H080 | Switch of A/C control panel | X | Cutting point |
| | | A | Connector H080 | * | Wiring colours may vary. |
| | | B | Connector H080 | | |

Legend

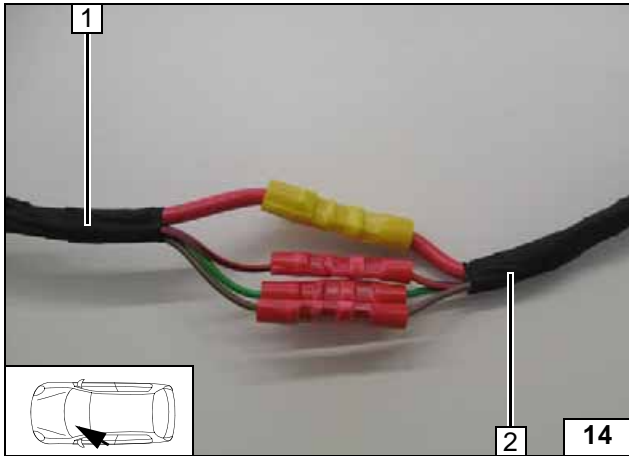
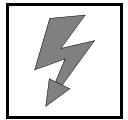

- 1 Wiring harness of passenger compartment relay and fuse holder
- 2 Wiring harness of heater

Connect-
ing same
colour
wires of
wiring har-
nesses

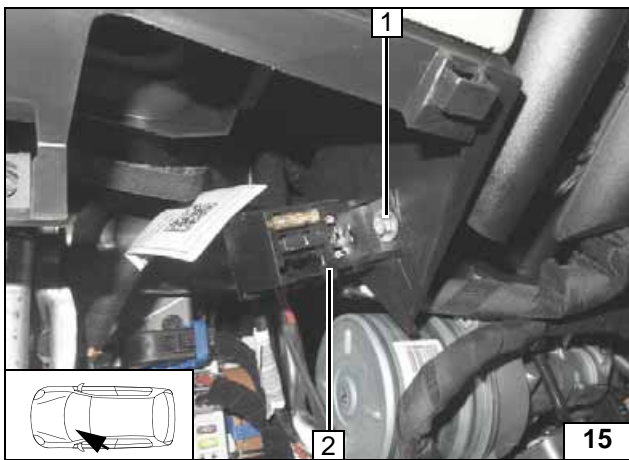

- 1 5.5 mm dia. hole, M5x16 bolt, large diameter washer [2x], nut
- 2 Passenger compartment relay and fuse holder

Installing
relay and
fuse holder
of passen-
ger com-
partment

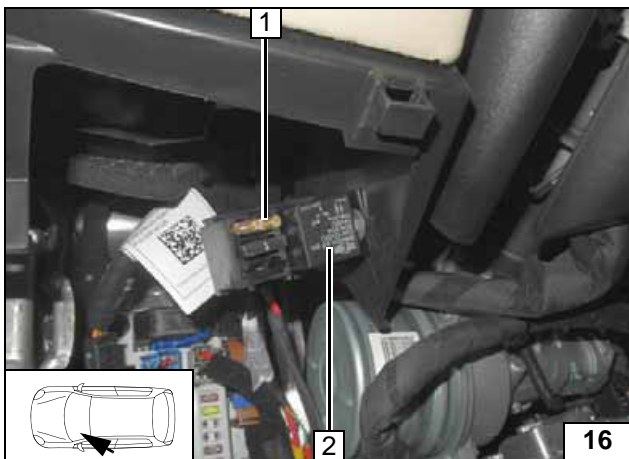

- 1 25A fuse F4
- 2 K1 relay

Installing K1
relay and F4
fuse

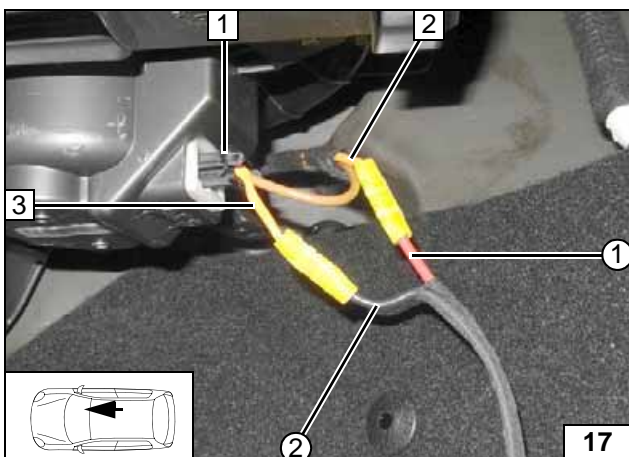

- 1 2-pin connector of fan motor N085
- 2 Red (rt) or orange (or) wire of fuse F08
- 3 Red (rt) or orange (or) wire of 2-pin connector N085/1
- ① Red (rt) wire from K1/87a, fan wiring harness
- ② Black (sw) wire from K1/30, fan wiring harness

Connec-
tion of fan
motor

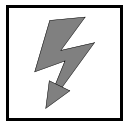

Fan Controller for Automatic Air-Conditioning

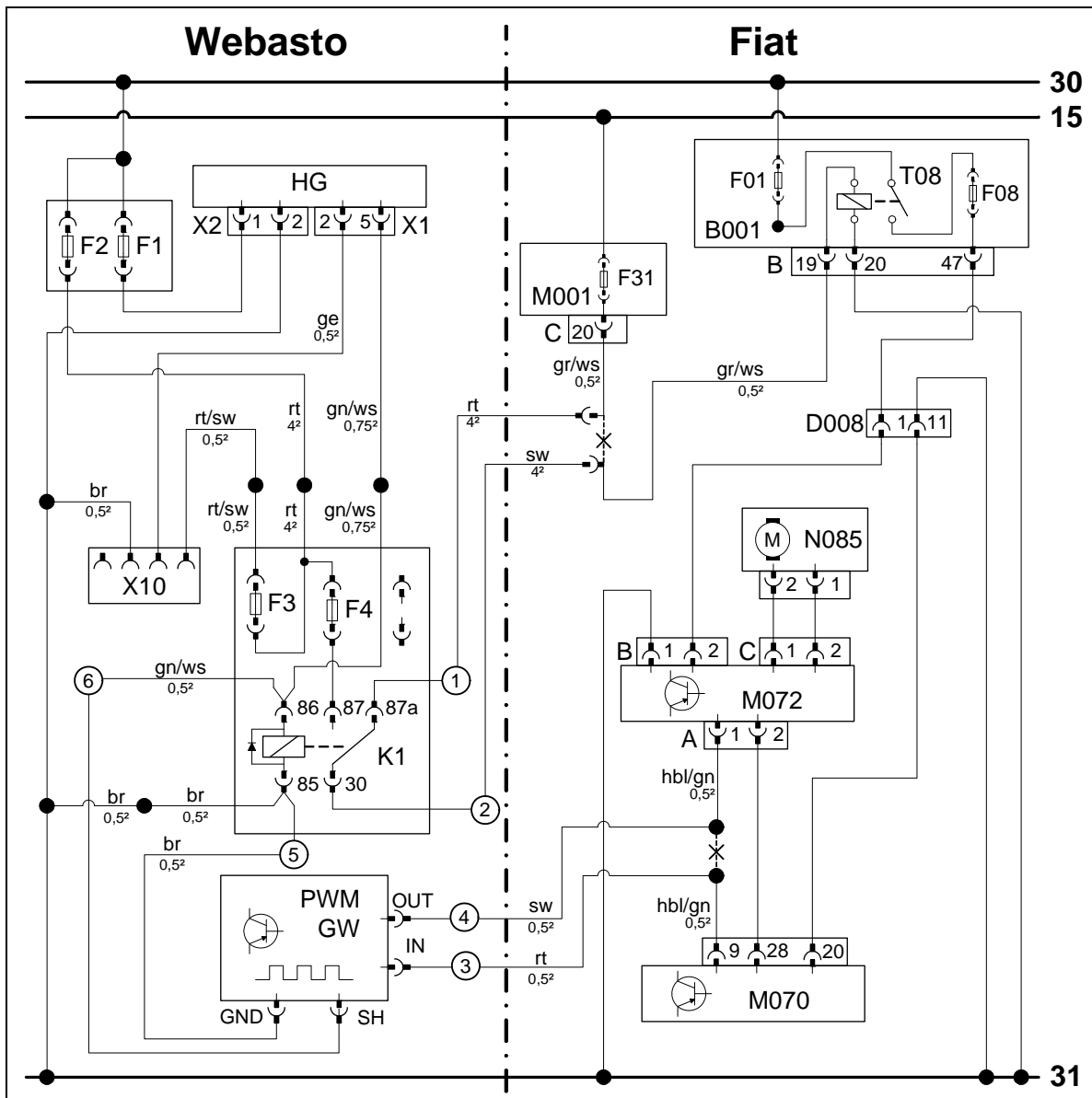

Wiring diagram

| Webasto components | | Vehicle components | | Colours and symbols | |
|----------------------------|-----------------------------------|--------------------|--|--------------------------|---------------|
| HG | TT-Evo Heater | B001 | Central electrical box in engine compartment | rt | red |
| X1 | 6-pin heater connector | T08 | Fan relay | sw | black |
| X2 | 2-pin heater connector | F01 | 70A fuse | ge | yellow |
| F1 | 20A fuse | F08 | 40A fuse | gn | green |
| F2 | 30A fuse | B | Connector B001 | br | brown |
| X10 | 4-pin connector of heater control | M001 | Body computer | gr | grey |
| F3 | 1A fuse | F31 | 5A fuse | ws | white |
| F4 | 5A fuse | C | 20-pin connector M001 | | |
| K1 | Fan relay | D008 | Plug connection | | |
| PWM GW | Pulse width modulator | N085 | Fan motor | | |
| Settings of PWM GW: | | M072 | Fan controller | | |
| Duty cycle: 25% | | A | M072 connector | | |
| Frequency: 1000Hz | | B | M072 connector | | |
| Voltage: 4.8V | | C | M072 connector | | |
| Function: High side | | M070 | A/C control unit | X | Cutting point |
| | | | | Wiring colours may vary. | |

Legend

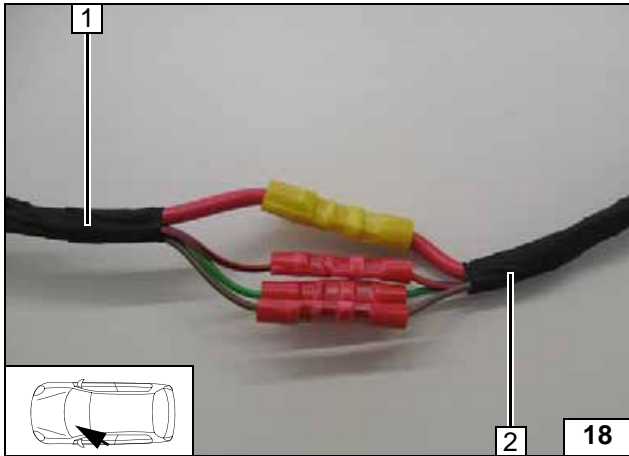

- 1 Wiring harness of passenger compartment relay and fuse holder
- 2 Wiring harness of heater

Connect-
ing same
colour
wires of
wiring har-
nesses

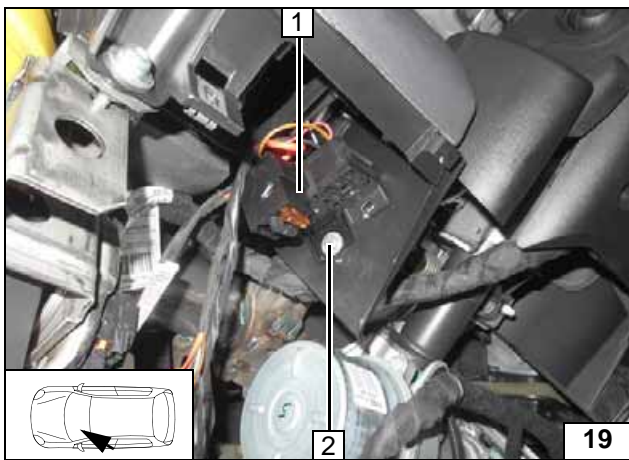

- 1 Passenger compartment relay and fuse holder
- 2 5.5 mm dia. hole, M5x16 bolt, large diameter washer [2x], nut

Installing
relay and
fuse holder
of passen-
ger com-
partment

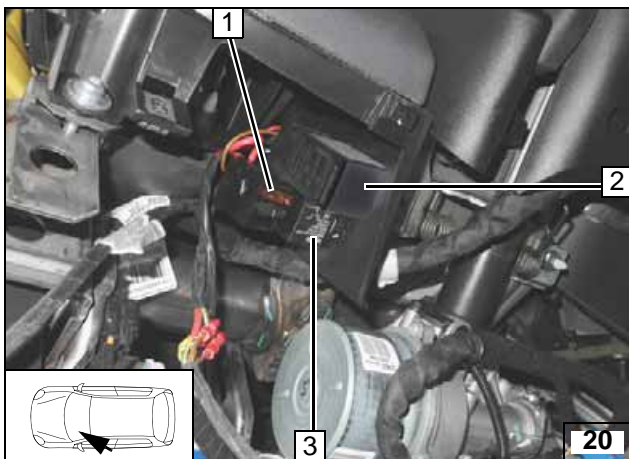

- 1 5A fuse F4
- 2 PWM GW
- 3 K1 relay

Installing K1
relay, PWM
GW and fuse
F4

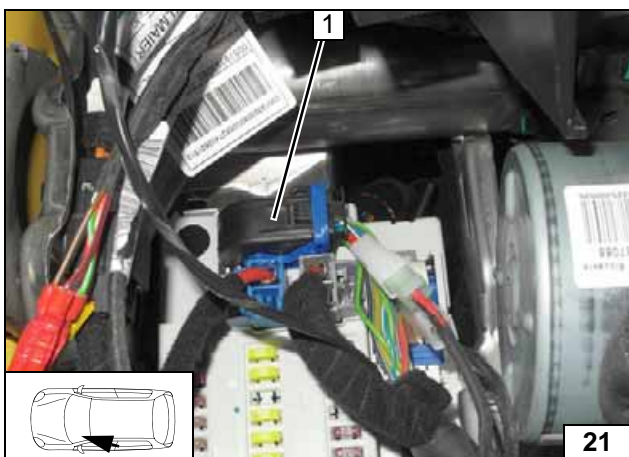

Detach 20-pin connector C 1 from Body Computer (M001) and dismantle.



Connec-
tion of
Body Com-
puter

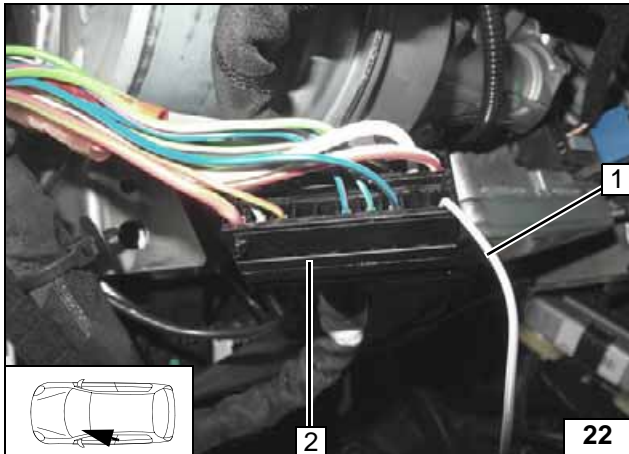

Separate grey/white (gr/ws) wire 1 100mm behind the plug connection. Reassemble the connector housing.

- 1 Grey/white (gr/ws) wire of connector C, pin 20
- 2 20-pin connector C (M001)

Connection of Body Computer

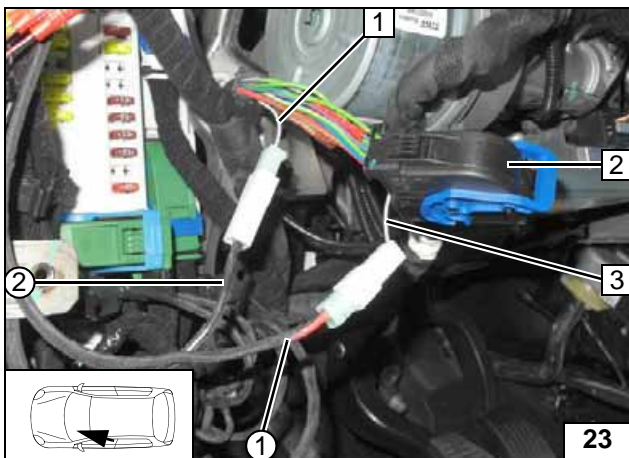

- 1 Grey/white (gr/ws) wire of connector B (B001), pin 19
- 2 20-pin connector C (M001)
- 3 Grey/white (gr/ws) wire of connector C (M001), pin 20
- ① Red (rt) wire from K1/87a, fan wiring harness
- ② Black (sw) wire from K1/30, fan wiring harness

Connection of Body Computer

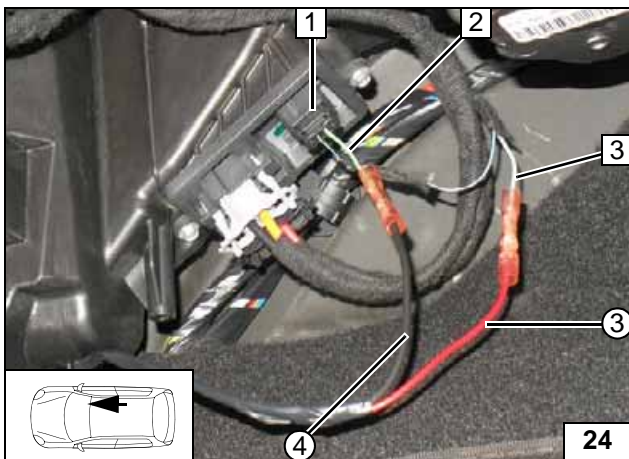

- 1 2-pin connector A (M072)
- 2 Light blue/green (hbl/gn) wire of connector A (M072), pin 1
- 3 Light blue/green (hbl/gn) wire of connector (M070), pin 9
- ③ Red (rt) wire of PWM GW/IN
- ④ Black (sw) wire of PWM GW/OUT

Connecting fan controller

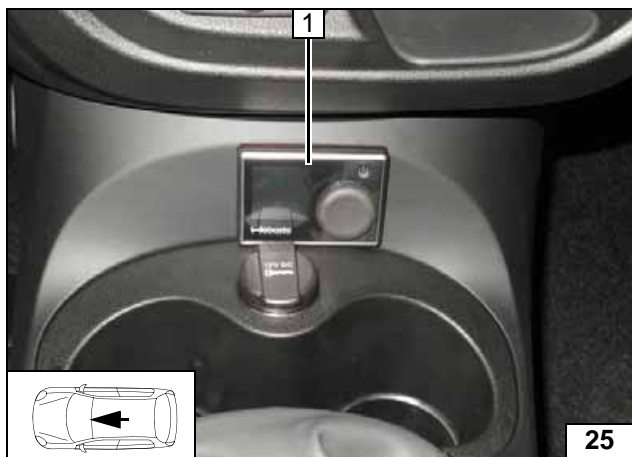

MultiControl CAR Option

- 1 MultiControl CAR



Installing
MultiControl
CAR

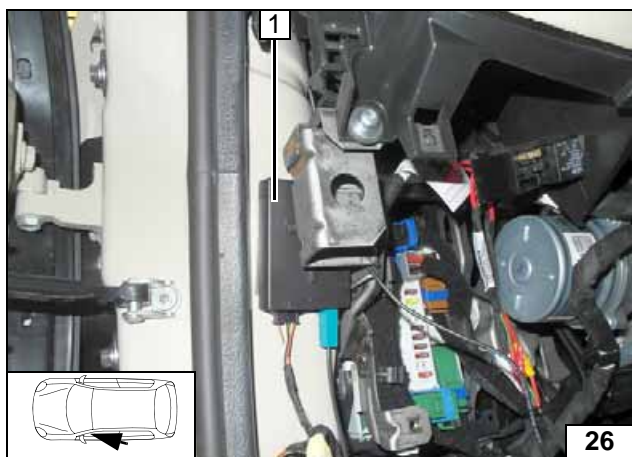

Remote Option (Telestart)

Degrease adhesive base. Fasten receiver 1 with adhesive tape.



Installing
receiver

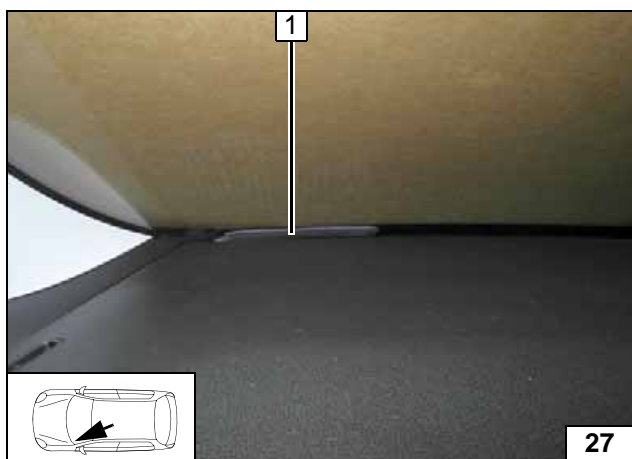

- 1 Antenna

Installing
antenna

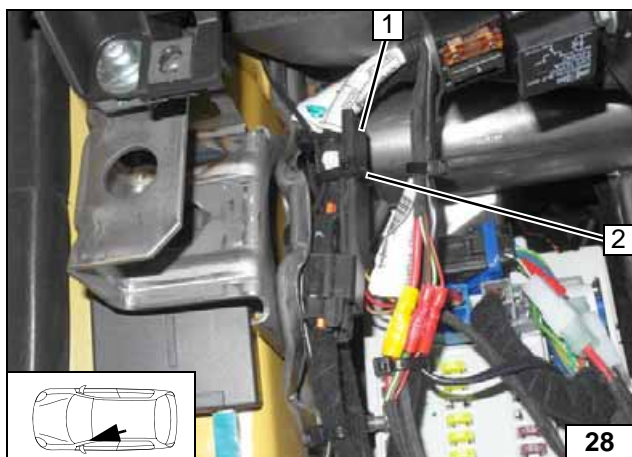

Temperature sensor T100 HTM

Fasten temperature sensor 1 to original vehicle wiring harness using a cable tie.

- 2 Cable tie



Installing
tempera-
ture sensor



Remote Option (Thermo Call)

Degrease adhesive base. Fasten receiver 1 with adhesive tape.

Installing receiver



1 Antenna

Installing antenna

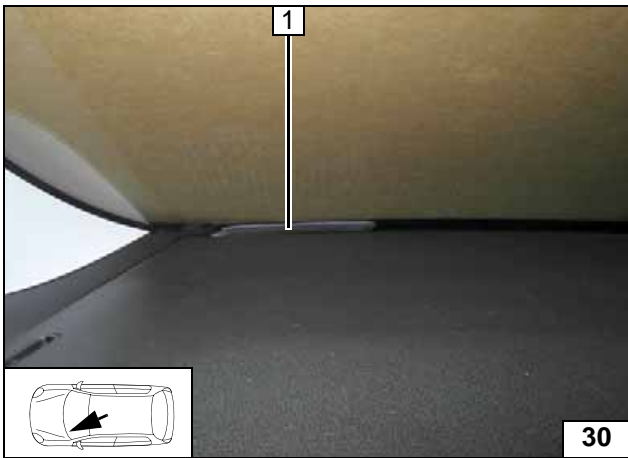

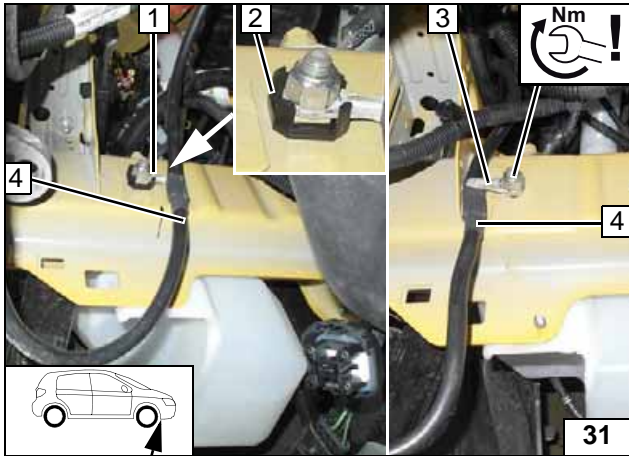
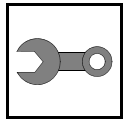

Preparing Installation Location

Align earth cable 4 position. Discard twist protection 2.

- 1 Position before
- 3 Position after



Aligning earth cable

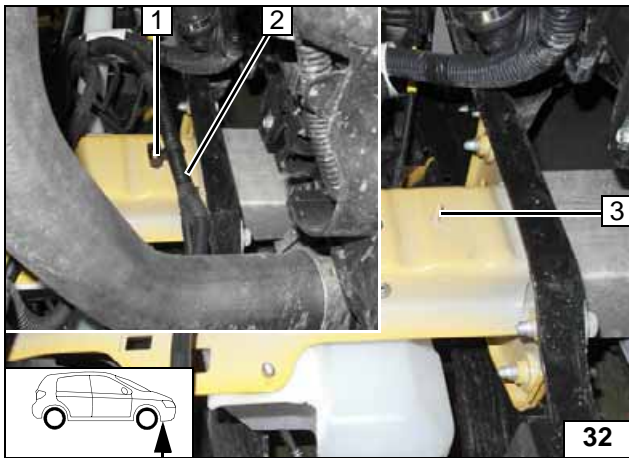

Remove original vehicle line 2 from stud bolt 1.

- 1 Stud bolt before (wiring harness mounted)
- 3 Stud bolt after (stud bolt exposed)



Exposing stud bolt

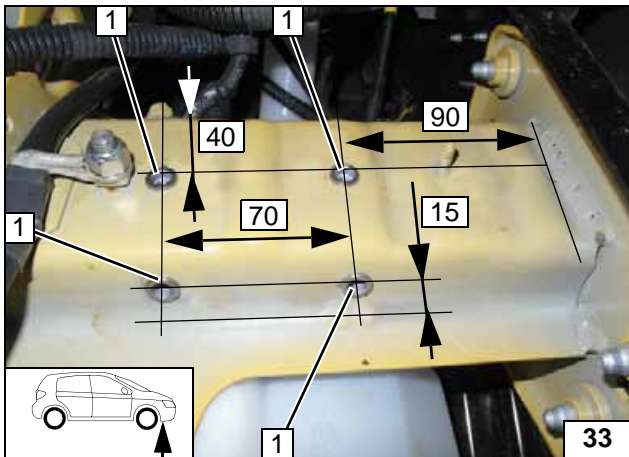

- 1 9.1 mm dia. hole, mount rivet nut [4x each]

Installing rivet nuts

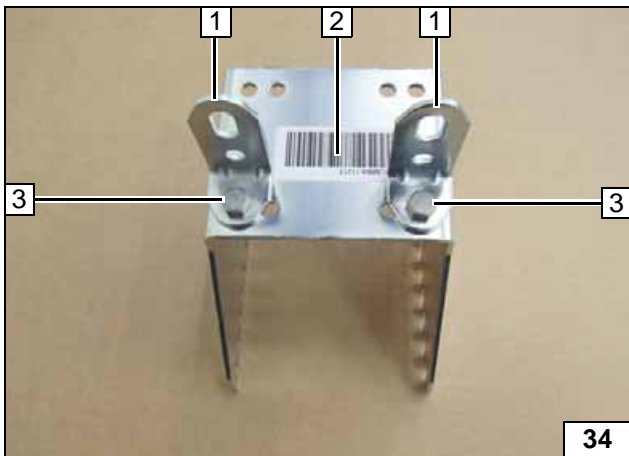

- 1 Angle bracket [2x]
- 2 Bracket
- 3 M6x12 bolt, flanged nut [2x each]

Preparing bracket

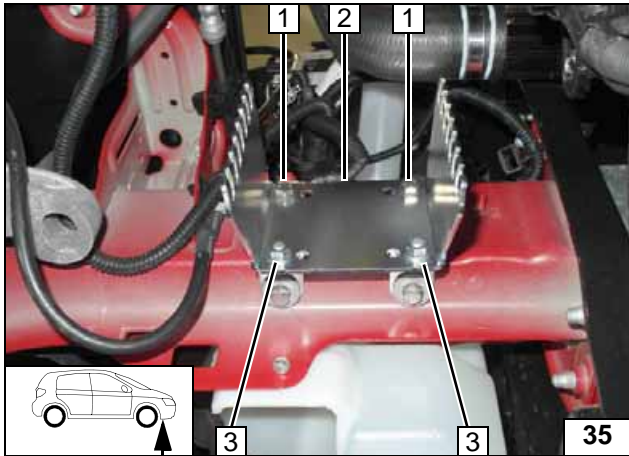
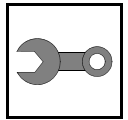

Insert 5 mm and 10 mm shims between bracket 2 and frame side member.

- 1 M6x35 bolt, spring lockwasher, 10 mm shim, 5 mm shim [2x each]
- 3 M6x20 bolt, spring lockwasher, large diameter washer [2x each]



Installing bracket

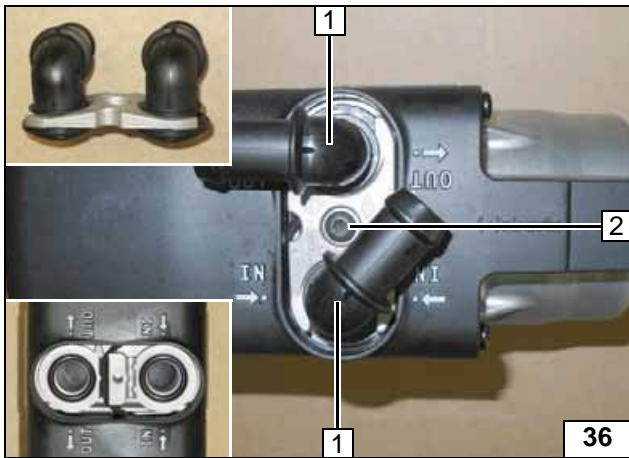

Preparing Heater

- 1 Water connection piece, sealing ring [2x each]
- 2 5x15 self-tapping bolt, retaining plate of water connection pieces



Installing water connection pieces

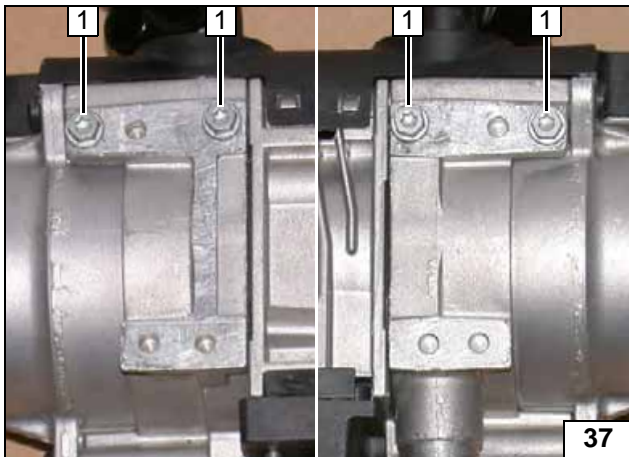

Screw 5x13 self-tapping bolts 1 [4x] into existing holes by a maximum of 3 thread turns.



Premounting bolts loosely

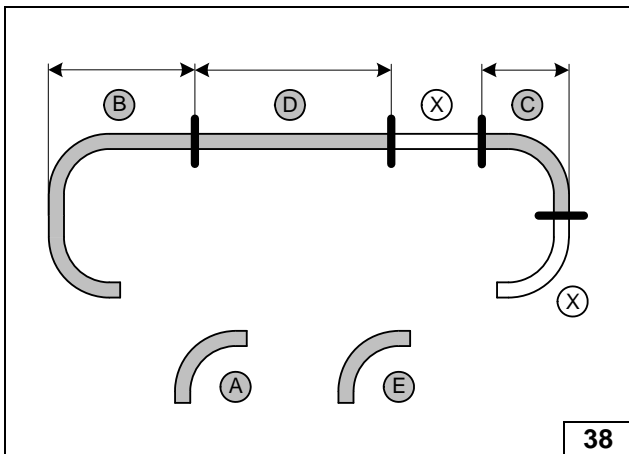

Discard section X.
Hose A = 18mm dia., 90° moulded hose
Hose E = 18mm dia., 90° moulded hose

- B = 380
- C = 110
- D = 480



Cutting hoses to length

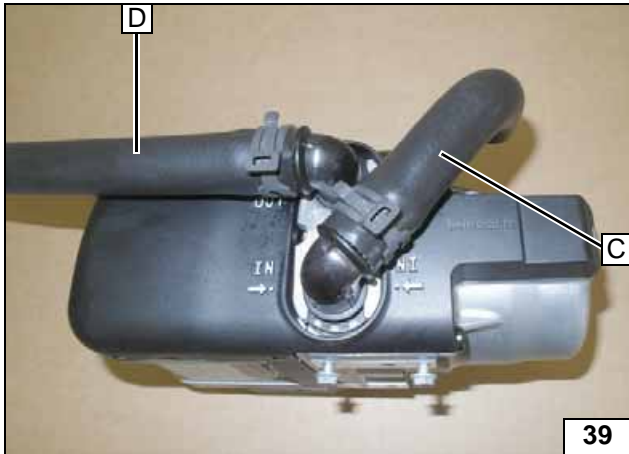

All spring clips = 25mm dia.



Premounting hoses

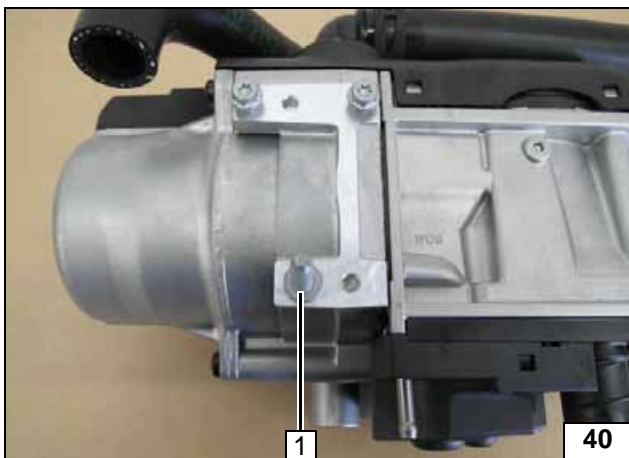

1 M5x11 x M6x25 stud bolt

Installing stud bolt

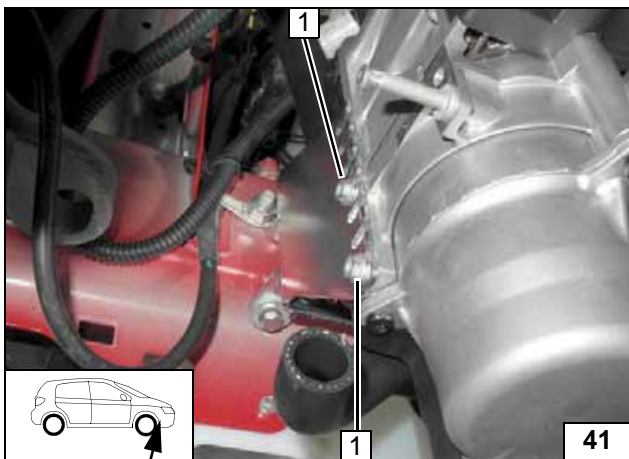

Installing Heater

1 Tighten 5x12 self-tapping bolt [2x]

Installing heater

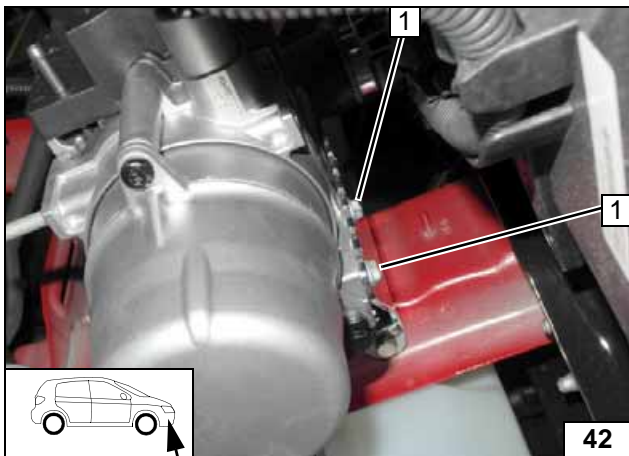

1 Tighten 5x12 self-tapping bolt [2x]

Installing heater







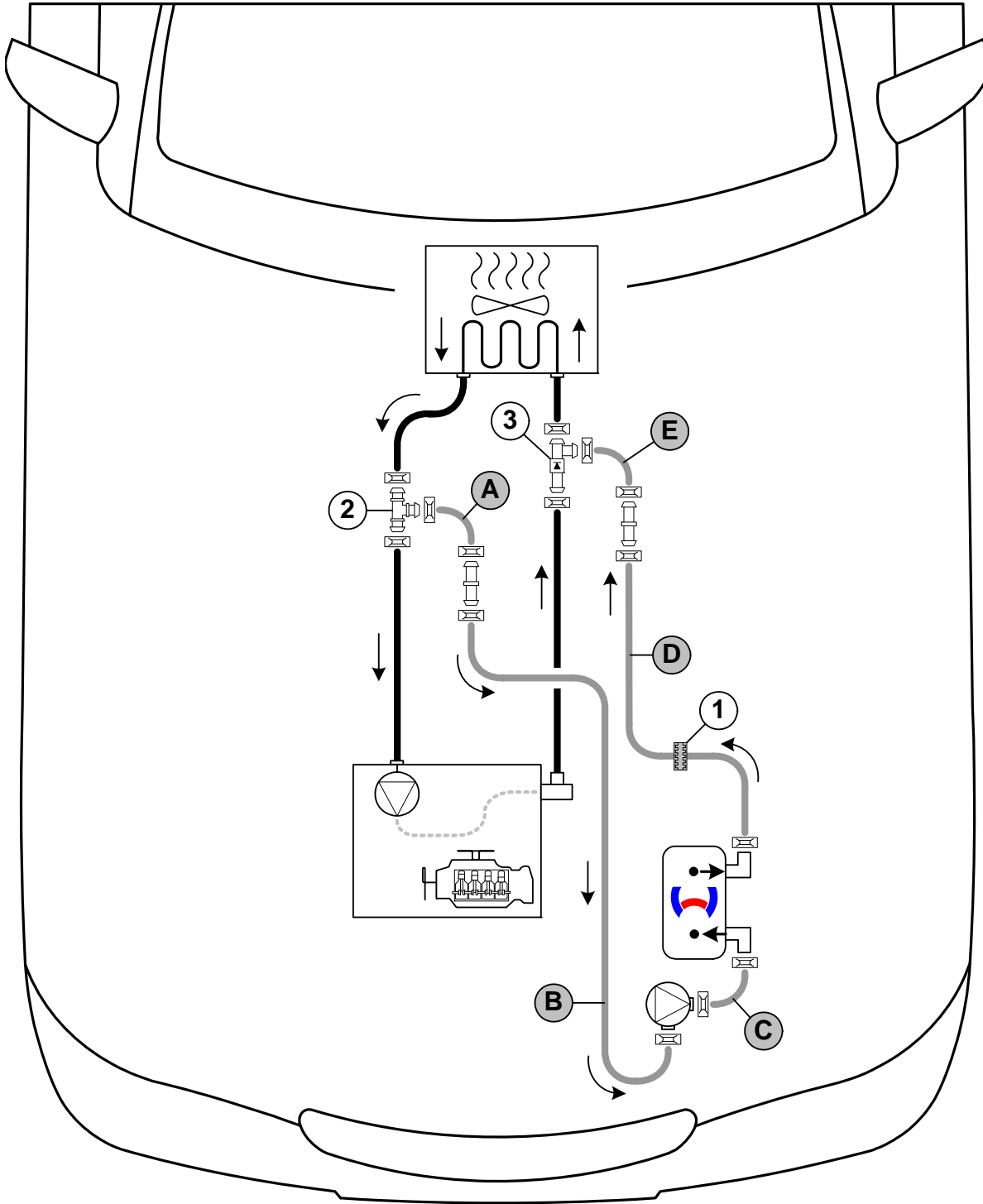

Coolant Circuit

WARNING!

Any coolant running off should be collected in an appropriate container. Install hoses so that they are kink-free. Unless specified otherwise, always fasten using cable ties. Position clamps so that other hose cannot be damaged. When installing the hoses, the heater must be filled with coolant. The connection is made according to the "island circuit" model and is based on the following diagram:



Hose routing diagram

All spring clips  = 25mm dia. **1** = Black (sw) rubber isolator .
 All connecting pipes  and  = 18x18 mm dia. **2** = T-piece . **3** = Check valve 



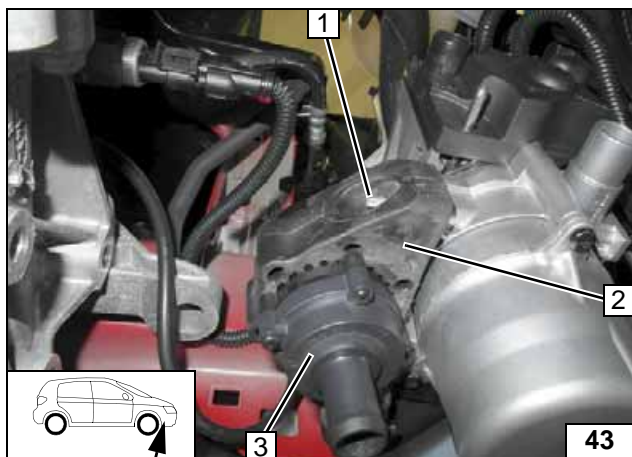

All vehicles

- 1 M6 flanged nut on stud bolt
- 2 Circulating pump mounting
- 3 Circulating pump

Installing circulating pump

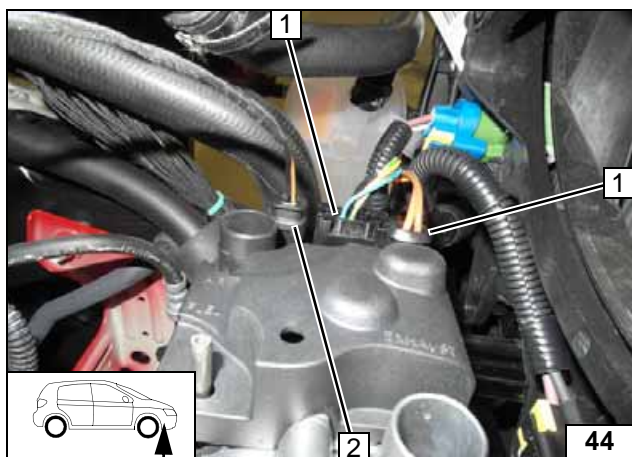

- 1 Connector of heater wiring harness [2x]
- 2 Connector of circulating pump wiring harness

Mounting wiring harness

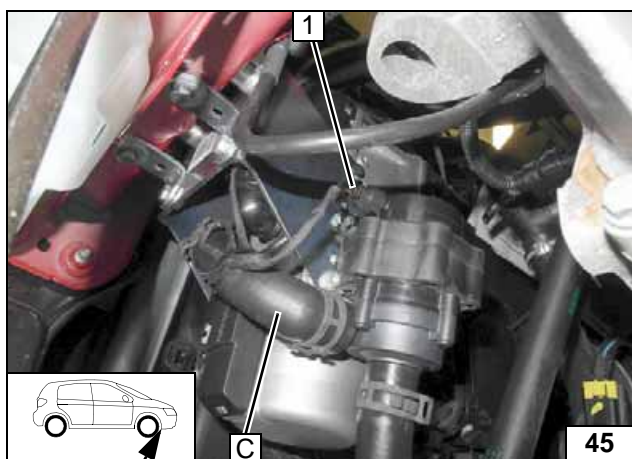

- 1 Connector of circulating pump wiring harness

Connecting circulating pump

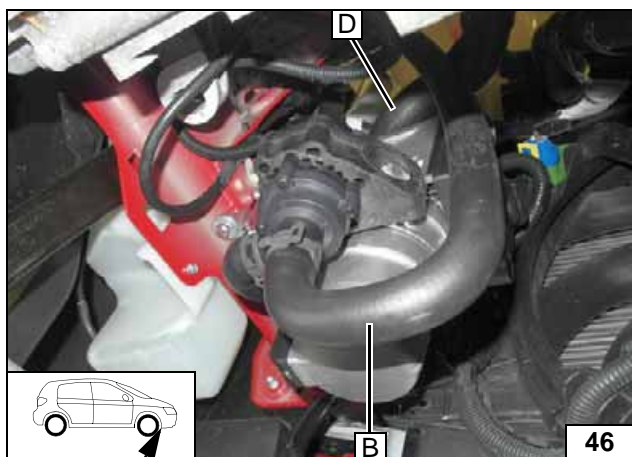

Connecting circulating pump

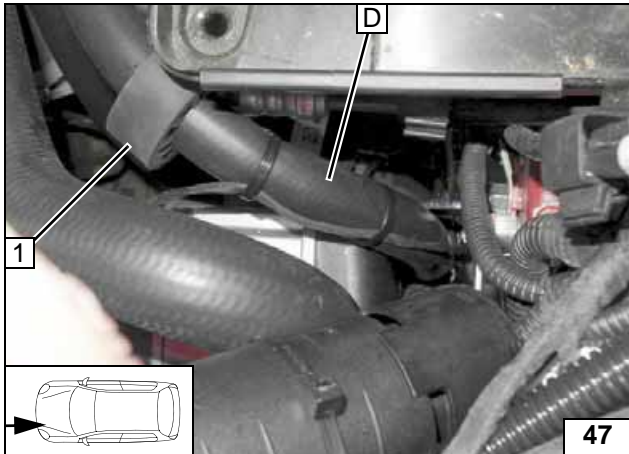

- 1 Slide on black (sw) rubber isolator and align

Routing in engine compartment

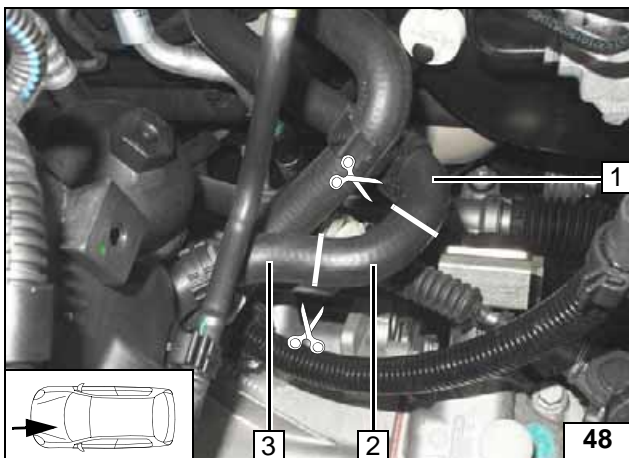

0.9 P

Cut hose of engine outlet / heat exchanger inlet at the markings.

- 1 Hose section of heat exchanger inlet
- 2 Discard section
- 3 Hose section of engine outlet



Cutting point

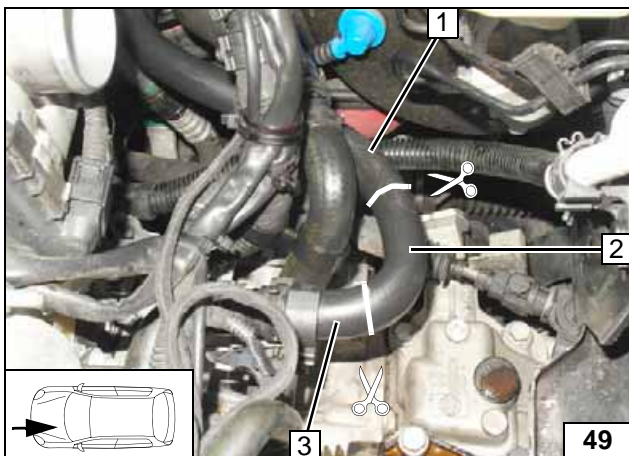

1.4 P

Cut hose of engine outlet / heat exchanger inlet at the markings.

- 1 Hose section of heat exchanger inlet
- 2 Discard section
- 3 Hose section of engine outlet



Cutting point for check valve

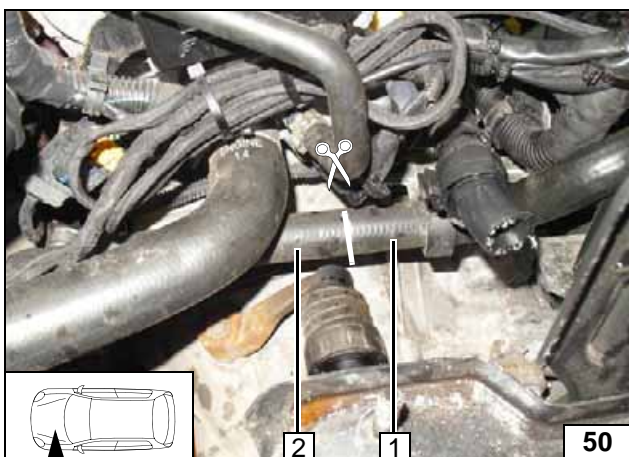

All vehicles

Further installation is for all vehicles almost identical and will be described by means of the 1.4 petrol vehicle. Cut hose of heat exchanger outlet / engine inlet at the marking.

- 1 Hose section of heat exchanger outlet
- 2 Hose section of engine inlet



Cutting point for T-piece

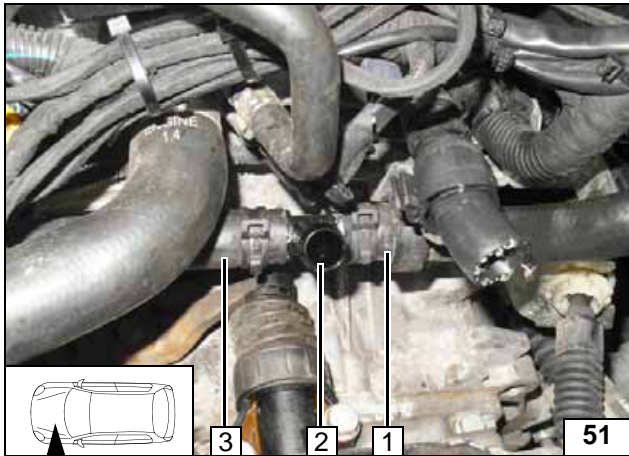

- 1 Hose section of heat exchanger outlet
- 2 T-piece
- 3 Hose section of engine inlet

Installing T-piece

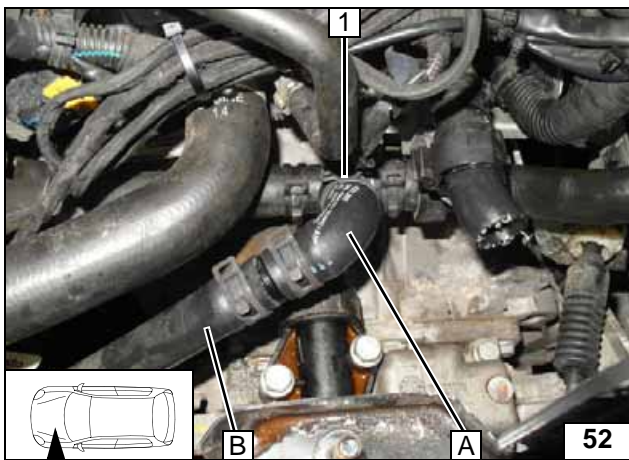

- 1 T-piece

Connecting T-piece

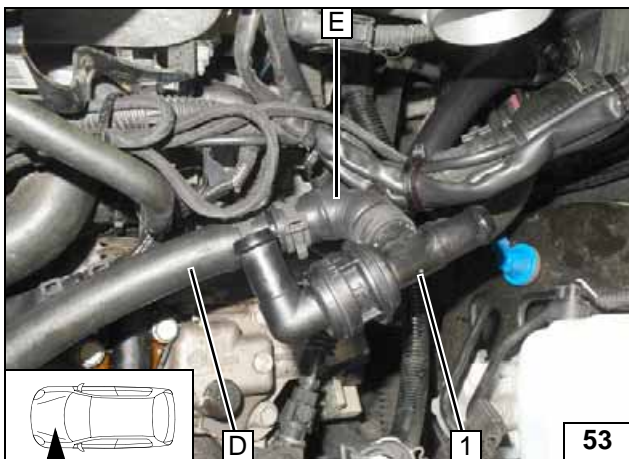

- 1 Check valve

Connecting check valve

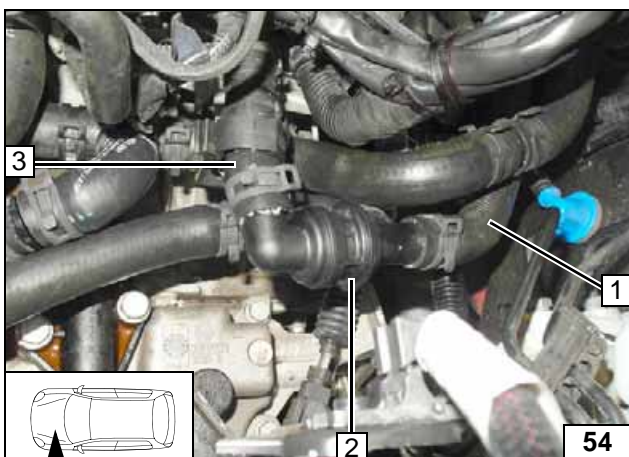

- 1 Hose of heat exchanger inlet
- 2 Check valve
- 3 Hose of engine outlet

Connecting check valve

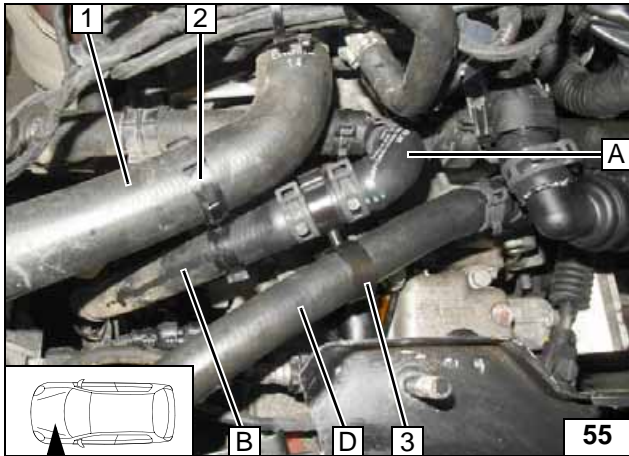

- 1 Original vehicle hose
- 2 25x37 hose bracket
- 3 25x25 hose bracket

**Mounting
hose
bracket**

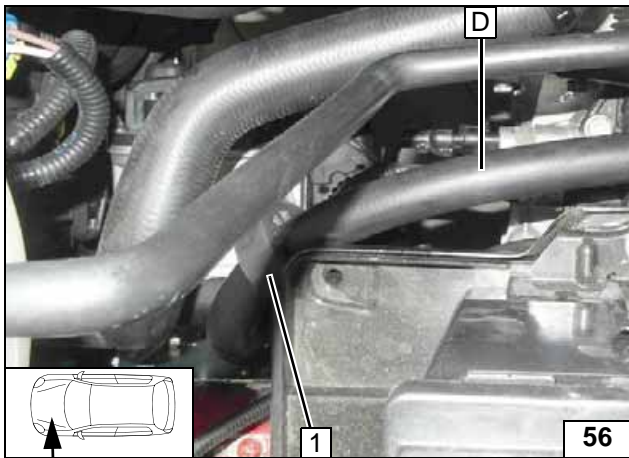

Ensure sufficient distance from neighbouring components, check freedom of movement, correct if necessary.



- 1 Position black (sw) rubber isolator

**Aligning
hoses**

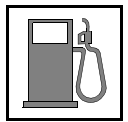

Fuel

CAUTION!

Open the vehicle's fuel tank cap, ventilate the tank and then re-close the tank lock.

Catch any fuel running off in an appropriate container.

Install fuel line and metering pump wiring harness so that they are protected against stone impact. Unless specified otherwise, always fasten using cable ties. Provide rub protection for fuel line and wiring harness in areas where there are sharp edges.

WARNING!

The fuel line and wiring harness are routed to the metering pump as shown in the wiring harness routing diagram.



- 1 Fuel line
- 2 90° moulded hose, 10mm dia. clamp [2x]

**Connect-
ing heater**

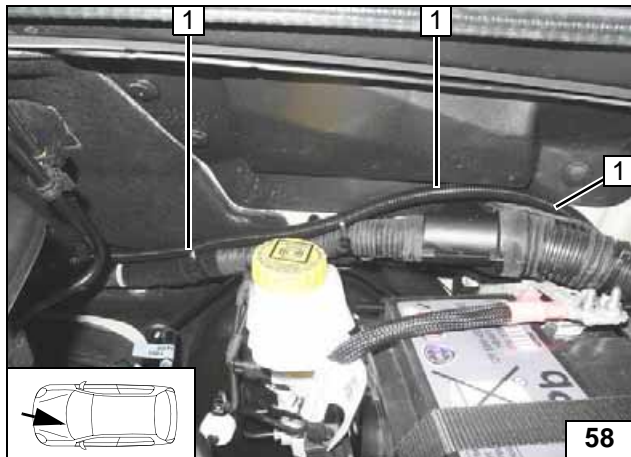

Route fuel line and wiring harness of metering pump in corrugated tube 1 to the right side along original vehicle wiring harness and further to the underbody along original vehicle fuel line and fasten.



**Installing
lines**



Route fuel line and wiring harness of metering pump in corrugated tube 1 to the installation location of the metering pump along original vehicle lines and fasten.



**Installing
lines**

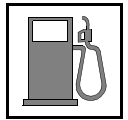

Processing and bending perforated bracket

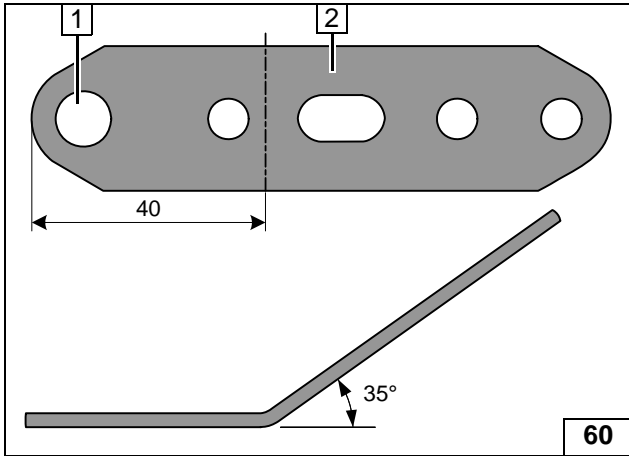

- 1 Drill out hole to 8.5 mm dia.
- 2 Perforated bracket

60

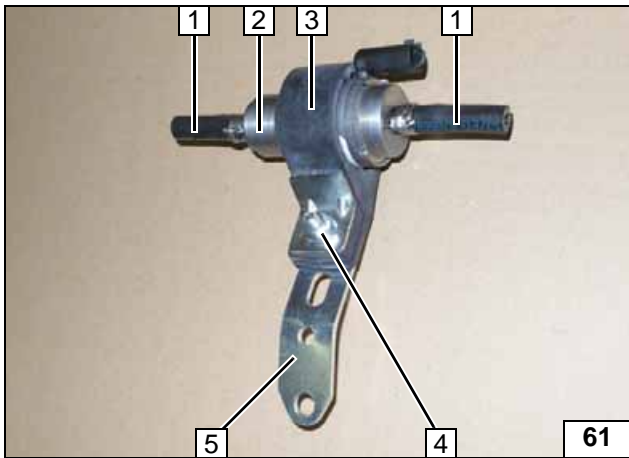

- 1 Hose section, 10mm dia. clamp [2x each]
- 2 Metering pump
- 3 Mounting of metering pump
- 4 M6x25 bolt, support angle bracket and flanged nut
- 5 Perforated bracket

61

Premounting metering pump

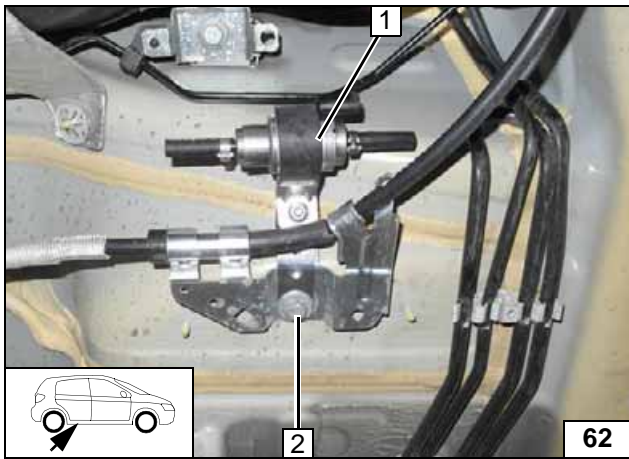

- 1 Metering pump premounted
- 2 Original vehicle bolt

62

Installing metering pump

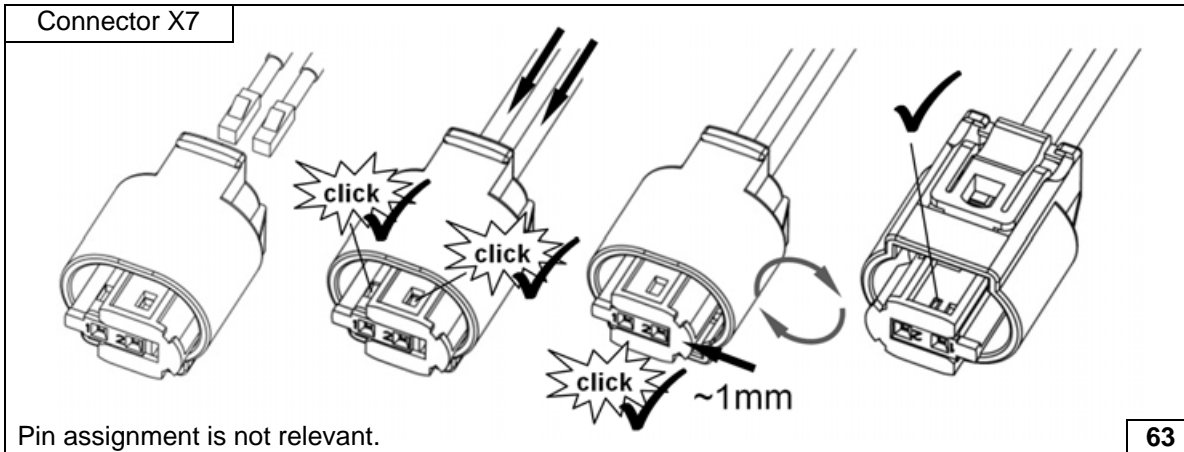

63

Completing metering pump connector

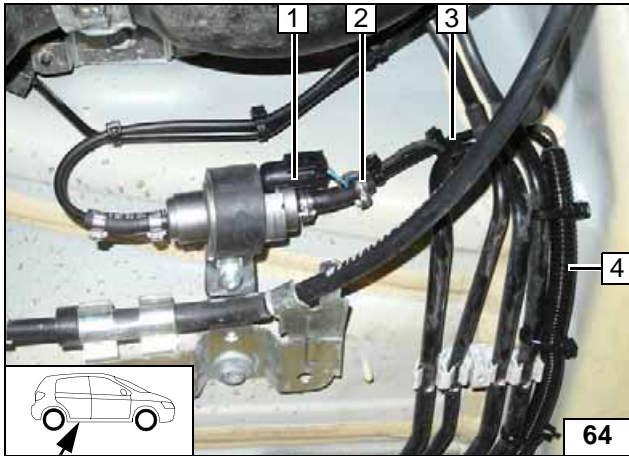
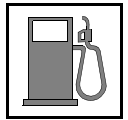

- 1 Wiring harness of metering pump, connector X7 mounted
- 2 10mm dia. clamp
- 3 Fuel line of heater
- 4 Fuel line of heater and wiring harness of metering pump in 10mm dia. corrugated tube

**Connect-
ing meter-
ing pump**

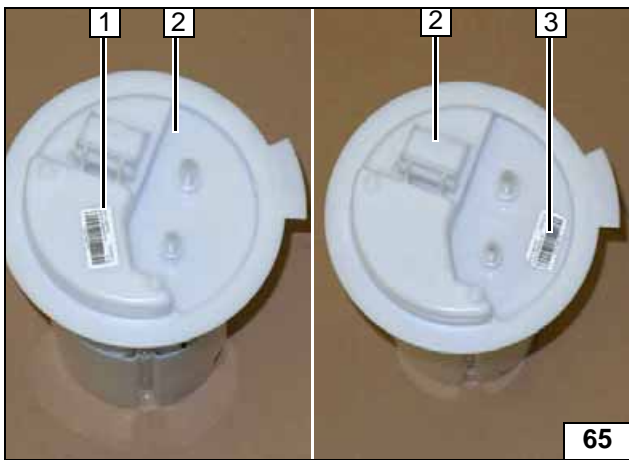

0.9 P

Remove and dismantle fuel-tank sending unit 2 according to manufacturer's instructions.

- 1 Pos. sticker before
- 3 Pos. sticker after



**Moving
sticker**

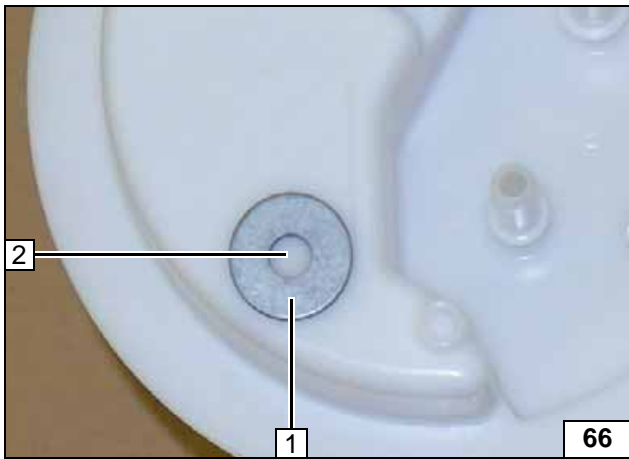

Place large diameter washer with outer dia. $d_a = 21.6\text{mm}$ 1 as shown.

- 2 Copy hole pattern, 6mm dia. hole



**Fuel ex-
traction**

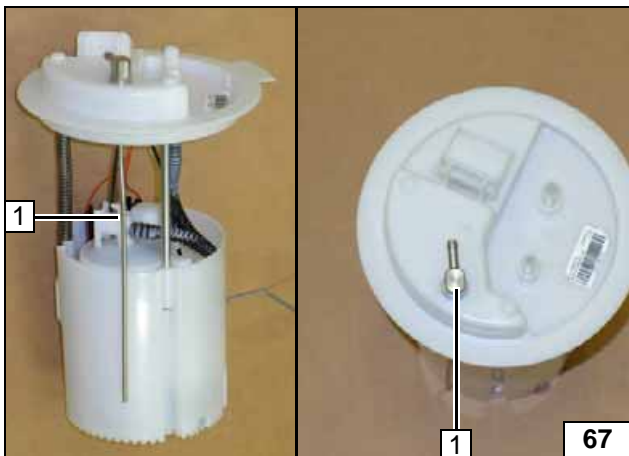

Shape fuel standpipe 1 according to template and cut to length.



**Installing
fuel stand-
pipe**

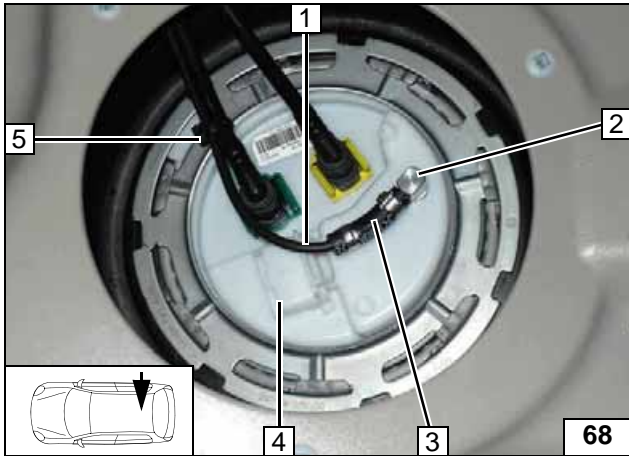
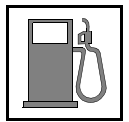

Install fuel-tank sending unit **4** in accordance with manufacturer's instructions.

- 1 Fuel line
- 2 Fuel standpipe
- 3 Hose section, 10mm dia. clamp [2x]
- 5 Cable tie



**Connect-
ing fuel line**

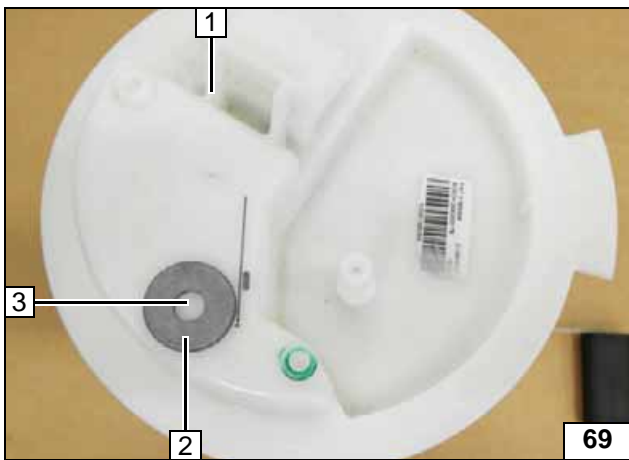

1.4 P

Remove fuel-tank sending unit **1** in accordance with the manufacturer's instructions. Place large diameter washer with outer dia. $d_a = 21.6\text{mm}$ **2** as shown.

- 3 Copy hole pattern, 6mm dia. hole



**Fuel ex-
traction**

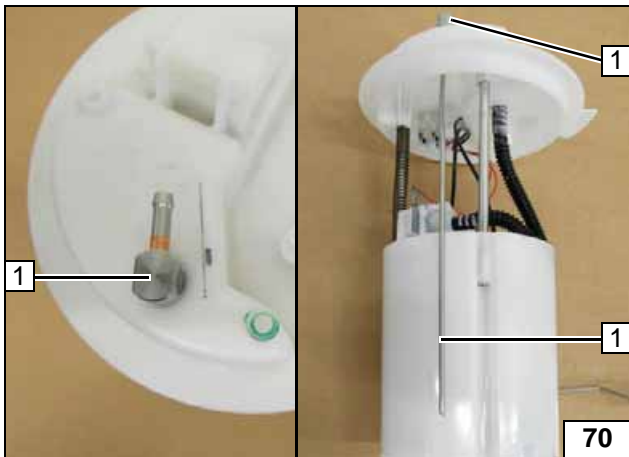

Shape fuel standpipe **1** according to template and cut to length.



**Installing
fuel stand-
pipe**

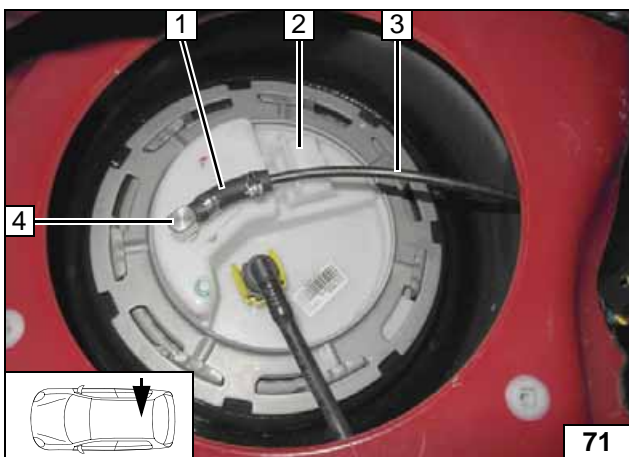

Install fuel-tank sending unit **2** in accordance with manufacturer's instructions.

- 1 Hose section, 10mm dia. clamp [2x]
- 3 Fuel line
- 4 Fuel standpipe



**Connect-
ing fuel line**

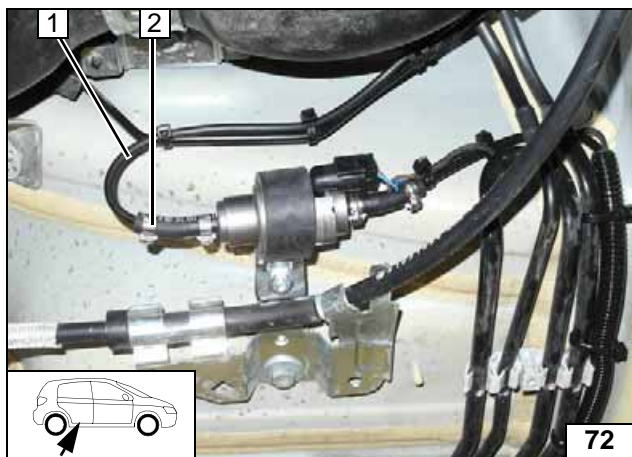

Check the position of the components; adjust if necessary. Check that they have freedom of movement.



- 1 Fuel line of fuel standpipe
- 2 10mm dia. clamp

**Connect-
ing meter-
ing pump**

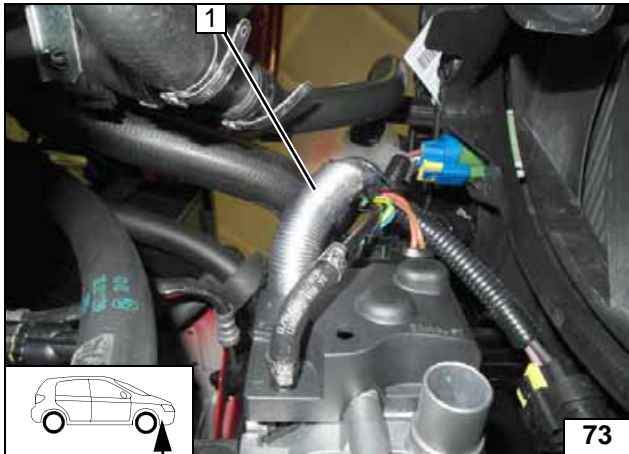
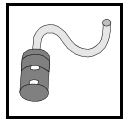

Combustion Air

1 Combustion air pipe

Installing combustion air pipe

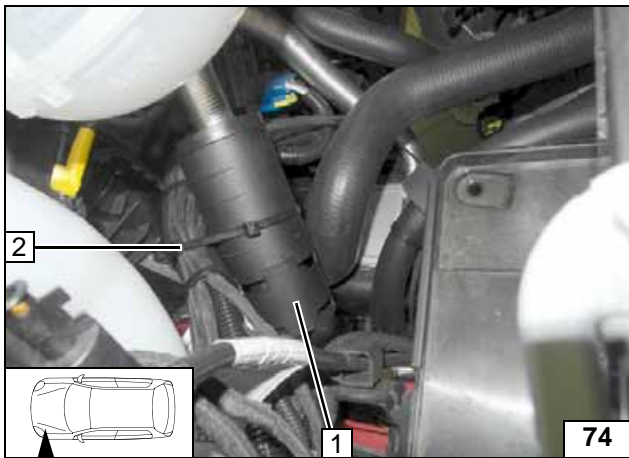

Fasten silencer 1 to original vehicle wiring harness using a cable tie 2.



Installing silencer



Fasten combustion air pipe 2 to reservoir with cable tie 1.



Fastening combustion air pipe

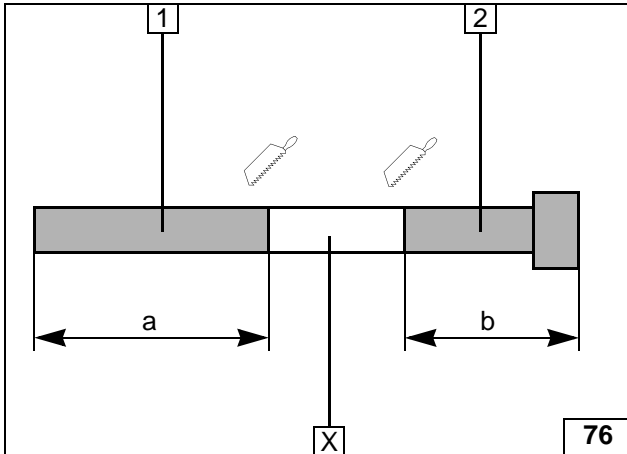
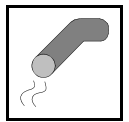

Exhaust Gas

Discard section X.

- 1 Exhaust pipe
a = 450
- 2 Exhaust end section
b = 90



Preparing exhaust pipe

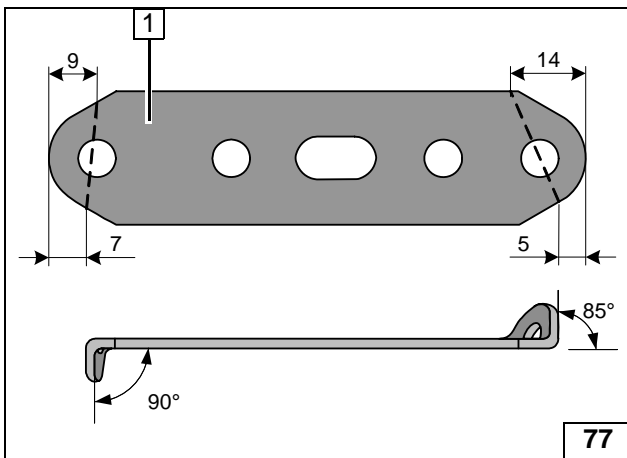

- 1 Perforated bracket



Bending perforated bracket

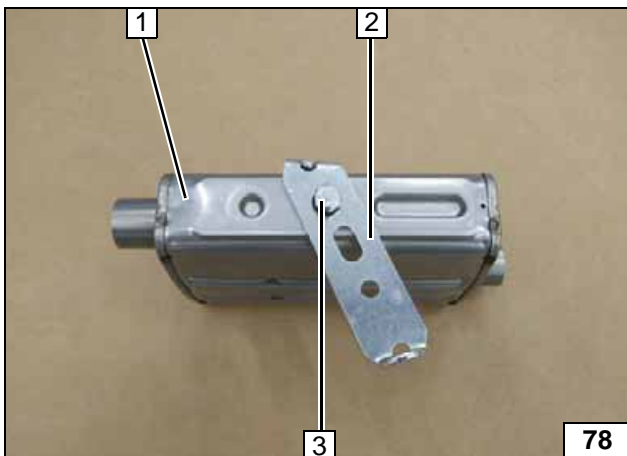

- 1 Silencer
- 2 Perforated bracket
- 3 M6x16 bolt, spring lockwasher

Premounting silencer

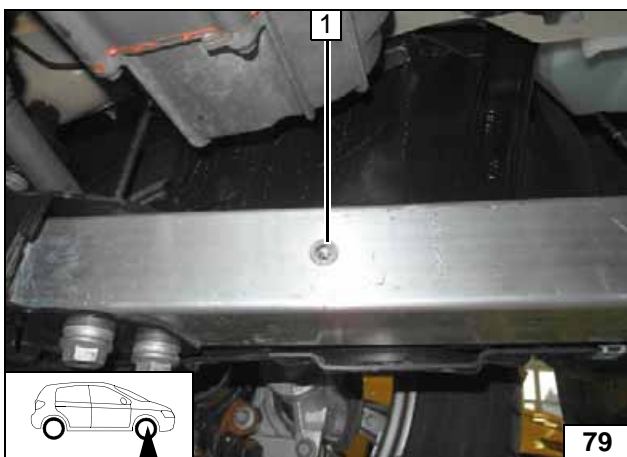

Drill out original vehicle hole 1 to 9.1 mm dia. Install rivet nut.



Preparing installation location

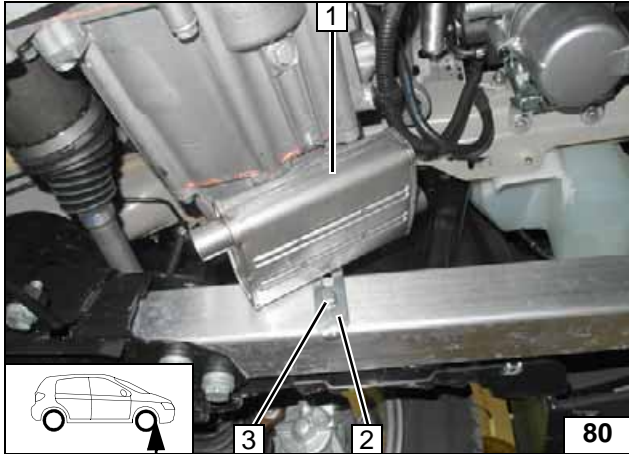
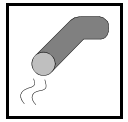

Check the position of the components; adjust if necessary. Check that they have freedom of movement.



- 1 Exhaust silencer
- 2 Premounted perforated bracket
- 3 M6x20 bolt, spring lockwasher

Installing exhaust silencer

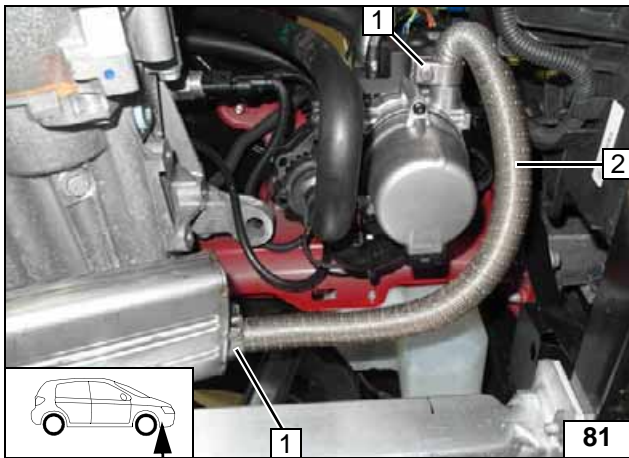

- 1 Hose clamp [2x]
- 2 Exhaust pipe

Installing exhaust pipe

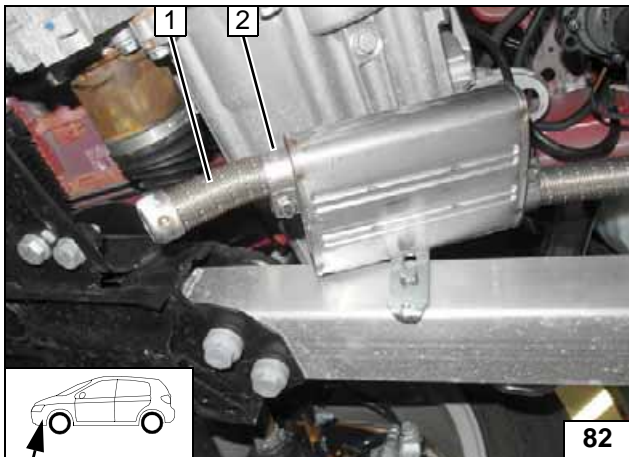

Ensure sufficient distance from neighbouring components, check freedom of movement, correct if necessary.



- 1 Exhaust end section
- 2 Hose clamp

Installing exhaust end section

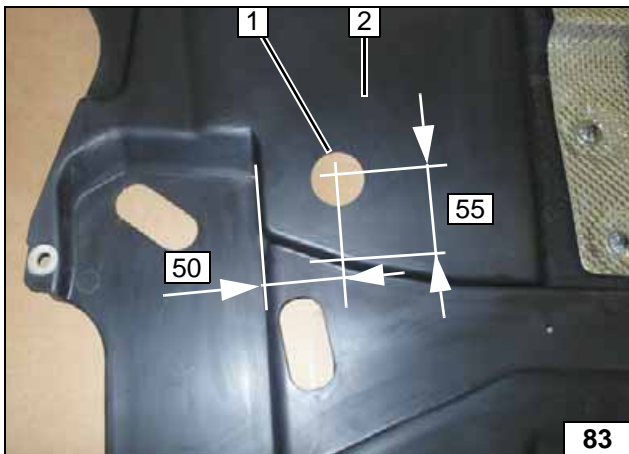

- 1 60 mm dia. hole
- 2 Underdrive protection (if present)

Cutting out underdrive protection



Final Work

WARNING!

Mount removed parts in reverse order. Check all hoses, clamps and all electrical connections for firm seating. Insulate all loose wires and tie back.

Only use manufacturer-approved coolant. Spray the heater components with anti-corrosion wax (Tectyl 100K, Order No. 111329).



- **Connect the battery.**
- **Fill and bleed the coolant circuit according to the vehicle manufacturer's specifications.**
- **Program MultiControl CAR, teach telestart transmitter.**
- **Make settings on A/C control panel according to the "Operating Instructions for the End Customer".**
- **Place the "Switch off parking heater before refuelling" caution label in the area of the filler neck.**
- **For initial startup and function check, please see installation instructions**

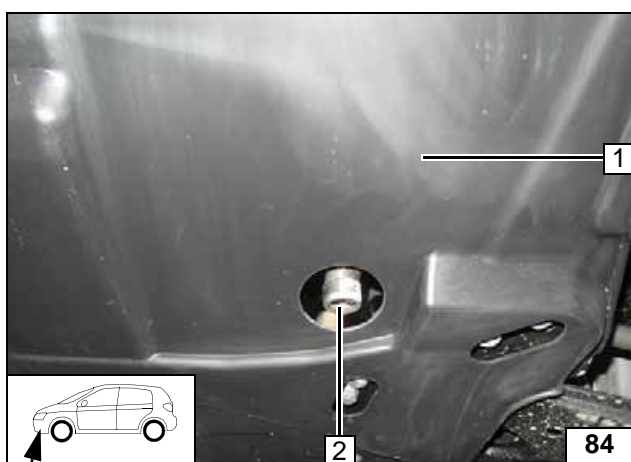

Align exhaust end section 2 flush with under-ride protection 1 (if present).



**Mounting
under-ride
protection**

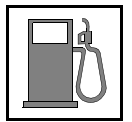

Template for Fuel Standpipe

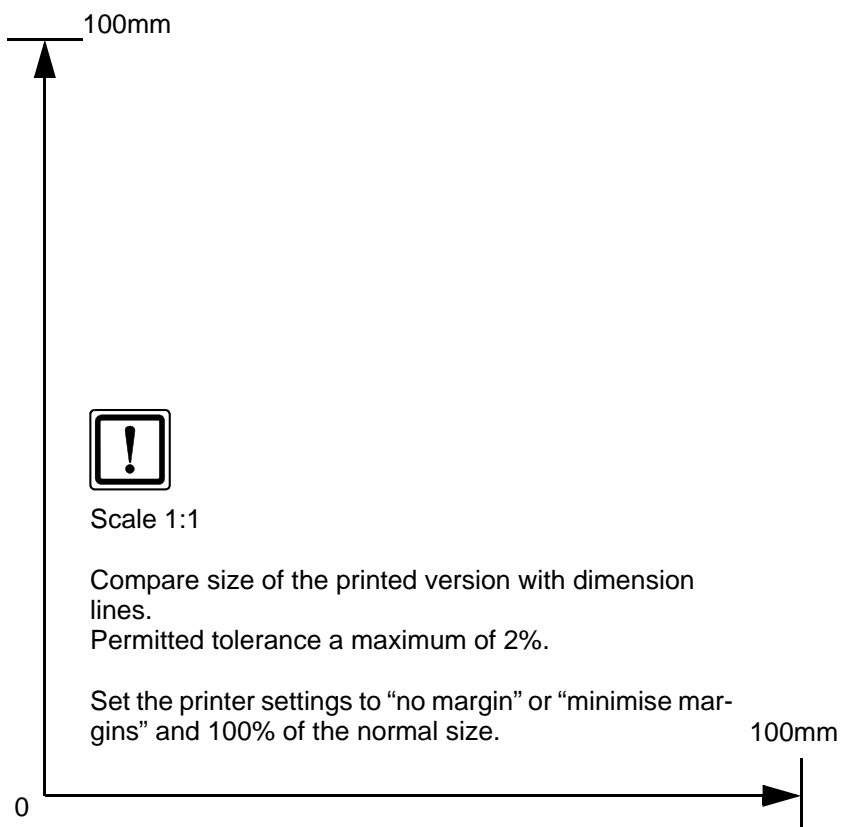
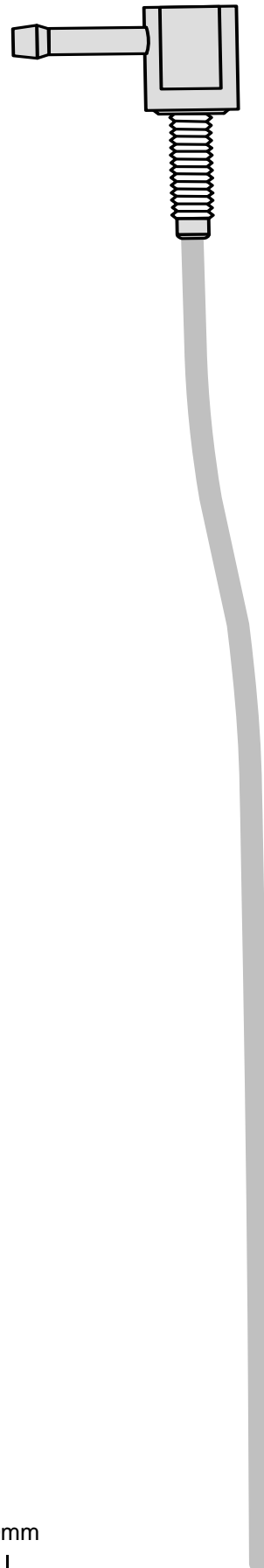

Operating Instructions for Manual Air-Conditioning

Please remove page and add to the vehicle operating instructions.

Note:

We recommend matching the heating time to the driving time.
 Heating time = driving time

Example:

For a driving time of approx. 20 min. (in one direction), we recommend not exceeding a switch-on time of 20 min.

Passenger compartment monitoring, if installed, must be deactivated in addition to the vehicle settings for the heating operation.

For instructions on deactivation, please refer to the operating instructions of the vehicle.

Before parking the vehicle, make the following settings:

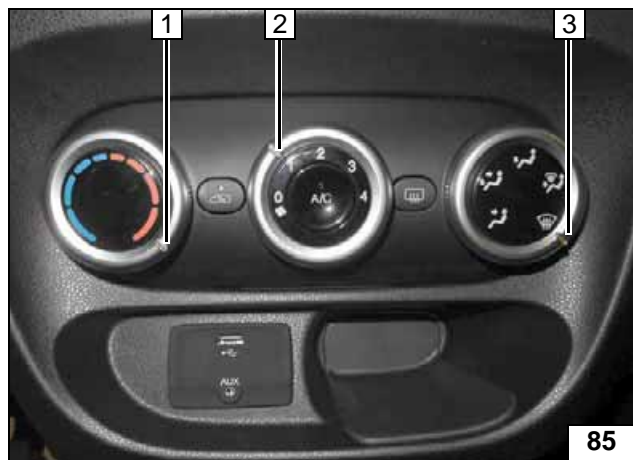

- 1 Set temperature to "max."
- 2 Set fan to level "1", or max. "2"
- 3 Air outlet onto windscreen



A/C control panel



- 1 20A heater fuse F1
- 2 30A main fuse F2 of passenger compartment

Engine compartment fuses

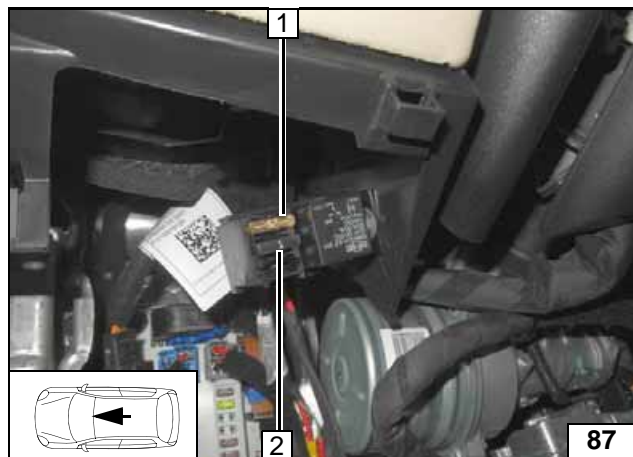

- 1 25A fan fuse F4
- 2 1A fuse F3 of heater control

Passenger compartment fuses



Operating Instructions for Automatic Air-Conditioning

Please remove page and add to the vehicle operating instructions.

Note:

We recommend matching the heating time to the driving time.
Heating time = driving time

Example:

For a driving time of approx. 20 min. (in one direction), we recommend not exceeding a switch-on time of 20 min.

Passenger compartment monitoring, if installed, must be deactivated in addition to the vehicle settings for the heating operation.

For instructions on deactivation, please refer to the operating instructions of the vehicle.

Before parking the vehicle, make the following settings:



Note:

The fan speed need not be preset!

- 1 Set temperature to "32.0°C"
- 2 Air outlet faces "upward"



A/C control panel



- 1 20A heater fuse F1
- 2 30A main fuse F2 of passenger compartment

Engine compartment fuses

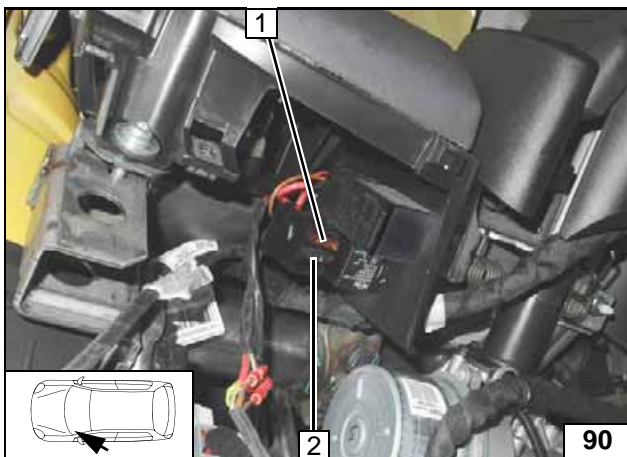

- 1 5A fan fuse F4
- 2 1A fuse F3 of heater control

Passenger compartment fuses