

# Water Heater

## Thermo Top Evo Parking Heater



# Installation Documentation

## Citroen C3 Picasso

### Validity

Manufacturer	Model	Type	EG-BE No. / ABE
Citroen	C3 Picasso	SH	e2 * 2001 / 116 * 0371 * ...

Motorisation	Fuel	Transmission type	Output in kW	Displacement in cm <sup>3</sup>	Engine code
1.4 VTi 95	Petrol	5-speed SG	70	1397	8FP0
1.6 VTi 120	Petrol	5-speed SG	88	1598	5FS0
1.6 HDI 90	Diesel	5-speed SG	69	1560	9H
1.6 HDI 115	Diesel	6-speed SG	84	1560	9H01

SG = Manual transmission

**From Model Year 2013**

**Left-hand drive vehicle**

**Verified equipment variants:** Manual air-conditioning  
 Front fog lights  
 Front fog lights LED daytime running lights

**Not verified:** Automatic air-conditioning

**Total installation time VTi:** approx. 9.5 hours

**Total installation time HDI:** approx. 10.5 hours

# Citroen C3 Picasso

## Table of Contents

Validity	1	Preparing Installation Location	14
Necessary Components	2	Preparing Heater	16
Installation Overview	2	Installing Heater	16
Information on Total Installation Time	2	Fuel	18
Information on Operating and Installation Instructions	3	Combustion Air	22
Information on Validity	4	Exhaust Gas	24
Technical Information	4	Coolant Circuit	26
Explanatory Notes on Document	4	Final Work	31
Preliminary Work	5	Template for Petrol Fuel Standpipe	32
Heater Installation Location	5	Template for Diesel Fuel Standpipe	33
Preparing Electrical System	6	Drilling Template for Heater Fastening	34
Electrical System	8	Operating Instructions for End Customer	35
Fan Controller	9		
Digital Timer	12		
Remote Option (Telestart)	12		
Remote Option (Thermo Call)	13		

## Necessary Components

- Basic delivery scope of *Thermo Top Evo* based on price list
- Installation kit for Citroen C3 Picasso 2013 Petrol and diesel: **1321136A**
- Heater control in accordance with price list and upon consultation with end customer
- In case of Telestart, indicator lamp in accordance with price list and in consultation with end customer

## Installation instructions:

- Arrange for the vehicle to be delivered with the tank only about ¼ full!
- The installation location of the push button in case of Telestart or Thermo Call should be confirmed with the end customer.
- Depending on the available space and manufacturer's instructions, we recommend the use of a vehicle battery with more electrical capacity.

## Installation Overview

### Legend:

1. Heater
2. Fuse holder of engine compartment
3. Gateway
4. Passenger compartment relay and fuse holder
5. Circulating pump
6. Digital Timer
7. Metering pump

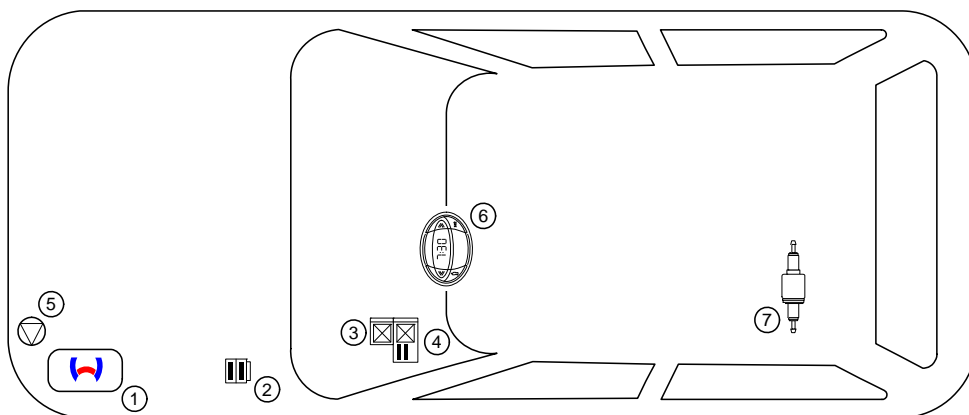

## Information on Total Installation Time

The total installation time includes the time needed for mounting and demounting of the vehicle-specific components, the heater specific installation time and all other times required for the system integration and initial start-up of the heater.

The total installation time may vary for vehicle equipment other than provided.

## Information on Operating and Installation Instructions

### 1 Important notes (not complete)

#### 1.1 Installation and Repair



The improper installation or repairing of Webasto heating and cooling systems can cause fire or the leakage of deadly carbon monoxide, leading to serious injury or death.



To install and repair Webasto heating and cooling systems you need to have completed a special company training course and have the appropriate technical documentation, special tools and special equipment.



Installation and repair may ONLY be carried out by persons trained and certified in a Webasto training course. NEVER try to install or repair Webasto heating or cooling systems if you have not completed a Webasto training course, you do not have the necessary technical skills and you do not have the technical documentation, tools and equipment available to ensure that you can complete the installation and repair work properly.

Only use genuine Webasto parts. See the Webasto air and water heaters accessories catalogue for this purpose.

#### 1.2 Operation

To ensure safe operation, we recommend having the heater checked every two years by an authorised Webasto dealer, especially when used over a long period and/or under extreme environmental conditions.

Do not operate the heater in closed rooms due to the danger of poisoning and suffocation.

Always switch off the heater before refuelling.

The heater may only be used with the prescribed fuel Diesel (DIN EN 590) or petrol (DIN EN 227).

The heater may not be cleaned with a high-pressure cleaner.

#### 1.3 Please note

ALWAYS follow all Webasto installation and operating instructions and observe all warnings.

To become familiar with and understand all functions and properties of the heater, the operating instructions must be read carefully and observed at all times.

For proper, safe installation and repair work, the installation instructions with all warnings and safety information must be carefully read and observed at all times. Please always contact a workshop authorised by Webasto for all installation and repair work.

#### Important

**Webasto shall assume no liability for defects, damage and injuries resulting from a failure to observe the installation, repair and operating instructions of the information contained in them.**

**This liability exclusion particularly applies to improper installations and repairs, installations and repairs by untrained persons or in the case of a failure to use genuine spare parts.**

**The liability due to culpable disregard to life, limb or health and due to damage or injuries caused by a wilful or reckless breach of duty remain unaffected, as does the obligatory product liability.**

**Installation should be carried out according to the general, standard rules of technology. Unless specified otherwise, fasten hoses, lines and wiring harnesses to original vehicle lines and wiring harnesses using cable ties. Insulate loose wire ends and tie back. Connectors on electronic components have to audibly click into place during installation.**

**Sharp edges should be fitted with rub protection. Spray unfinished body areas, e.g. drilled holes, with anti-corrosion wax (Tectyl 100K, Order No. 111329).**

**Observe the instructions and guidelines of the respective vehicle manufacturer for demounting and mounting vehicle specific components!**

**The initial startup is to be executed with the Webasto Thermo Test Diagnosis.**

**When installing an IPCU, the corresponding settings must be checked or adjusted before the installation.**

### 2 Statutory regulations governing installation

Guidelines	Thermo Top Evo
Heating Directive ECE R122	E1 00 0258
EMC Directive ECE R10	E1 04 5627

#### Note

The regulations of these guidelines are binding in the scope of the Directive 70/156/EEC and/or 2007/46/EC (for new vehicle models from 29/04/2009) and should also be observed in countries in which there are no special regulations.

#### Important

Failure to follow the installation instructions will result in the invalidation of the type approval for the heater and therefore invalidation of the general **homologation of the vehicle**.

#### Note

For vehicles with an EU permit, no entry in accordance with § 19 Sub-Section 4 of Annex VIII b to the Road Traffic Act is required.

### 2.1 Excerpt from the directive 2001/56/EC Appendix VII for the installation of the heater

Beginning of excerpt.

#### ANNEX VII

#### REQUIREMENTS FOR COMBUSTION HEATERS AND THEIR INSTALLATION

##### 1. GENERAL REQUIREMENTS

1.7.1. A clearly visible tell-tale in the operator's field of view shall inform when the combustion heater is switched on or off.

##### 2. VEHICLE INSTALLATION REQUIREMENTS

###### 2.1. Scope

2.1.1. Subject to paragraph 2.1.2. combustion heaters shall be installed according to the requirements of this Annex.

2.1.2. Vehicles of category O having liquid fuel heaters are deemed to comply with the requirements of this Annex.

###### 2.2. Positioning of heater

2.2.1. Body sections and any other components in the vicinity of the heater must be protected from excessive heat and the possibility of fuel or oil contamination.

2.2.2. The combustion heater shall not constitute a risk of fire, even in the case of overheating. This requirement shall be deemed to be fulfilled if the installation ensures an adequate distance to all parts and suitable ventilation, by the use of fire resistant materials or by the use of heat shields.

2.2.3. In the case of M2 and M3 vehicles, the heater must not be positioned in the passenger compartment. However, an installation in an effectively sealed envelope which also complies with the conditions in paragraph 2.2.2 may be used.

2.2.4. The label referred to in paragraph 1.4 or a duplicate, must be positioned so that it can be easily read when the heater is installed in the vehicle.

2.2.5. Every reasonable precaution should be taken in positioning the heater to minimise the risk of injury and damage to personal property.

###### 2.3. Fuel supply

2.3.1. The fuel filler must not be situated in the passenger compartment and must be provided with an effective cap to prevent fuel spillage

2.3.2. In the case of liquid fuel heaters, where a supply separate to that of the vehicle is provided, the type of fuel and its filler point must be clearly labelled

2.3.3. A notice, indicating that the heater must be shut down before refuelling, must be affixed to the fuelling point. In addition a suitable instruction must be included in the manufacturer's operating manual.

###### 2.4. Exhaust system

2.4.1. The exhaust outlet must be located so as to prevent emissions from entering the vehicle through ventilators, heated air inlets or opening windows.

###### 2.5. Combustion air inlet

2.5.1. The air for the combustion chamber of the heater must not be drawn from the passenger compartment of the vehicle.

2.5.2. The air inlet must be so positioned or guarded that blocking by rubbish or luggage is unlikely.

###### 2.6. Heating air inlet

2.6.1. The heating air supply may be fresh or recirculated air and must be drawn from a clean area not likely to be contaminated by exhaust fumes emitted either by the propulsion engine, the combustion heater or any other vehicle source.

2.6.2. The inlet duct must be protected by mesh or other suitable means.

###### 2.7. Heating air outlet

2.7.1. Any ducting used to route the hot air through the vehicle must be so positioned or protected that no injury or damage could be caused if it were to be touched.

2.7.2. The air outlet must be so positioned or guarded that blocking by rubbish or luggage is unlikely.

End of excerpt.

In multilingual versions the German language is binding.

# Citroen C3 Picasso

## Information on Validity

This installation documentation applies to Citroen C3 Picasso Petrol and diesel vehicles - for validity, see page 1 - from model year 2013 and later, assuming technical modifications to the vehicle do not affect installation, any liability claims excluded. Depending on the vehicle version and equipment, modifications may be necessary during installation with respect to these "installation instructions".

Vehicle and engine types, equipment variants and other specifications not listed in this installation documentation have not been tested. However, installation according to this installation documentation may be possible.

## Technical Information

### Special Tools

- Hose clamp pliers for auto-tightening hose clamps
- Hose clamp pliers for Clic hose clamps of type W
- Automatic wire stripper 0.2 - 6mm<sup>2</sup>
- Crimping pliers for cable lug / tab connector 0.5 - 6mm<sup>2</sup>
- Torque wrench for 2.0 - 10 Nm
- Hose clamping pliers
- Metric thread-setter kit
- Webasto Thermo Test Diagnosis with current software

### Dimensions

- All dimensions in mm.

### Tightening torque values

- Tightening torque values for 5x13 heater bolts and 5x11 heater stud bolts = 8Nm.
- Tightening torque values of 5x15 retaining plate of water connection piece bolts = 7Nm.
- Tighten other bolt connections in accordance with manufacturer's instructions or in accordance with state-of-the-art-technology.

## Explanatory Notes on Document

You will find an identification mark on the outside top right corner of the page in question to provide you with a quick overview of the individual working steps.

Special features are highlighted using the following symbols:

### Mechanical system



### Electrical System



### Coolant Circuit



### Combustion Air

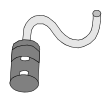

### Fuel



### Exhaust gas



### Software



Special risk of injury or fatal accidents.



Specific risk of damage to components.



Specific risk of fire or explosion.



Reference to general installation instructions of the Webasto component or to vehicle specific documents of the manufacturer



Reference to a special technical feature.



The arrow in the vehicle icon indicates the position on the vehicle and the viewing angle.

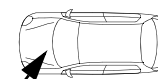

# Citroen C3 Picasso

## Preliminary Work

### Vehicle

- Open the fuel tank cap.
- Ventilate the fuel tank.
- Close the fuel tank cap again.
- Depressurise the cooling system.
- Disconnect and completely remove the battery with carrier.
- Remove the engine control unit.
- Remove the left front wheel.
- Remove the left wheel well trim, loosen it in the right front area.
- Remove the bumper.
- Remove the left-hand headlight.
- Remove the resonator with intake hose.
- Move the control unit and the relay (only Diesel).
- Remove the lower engine cover (if present).
- Remove the underride protection (if present).
- Remove the left-hand rear bench seat.
- Open the tank-fitting service lid.
- Remove the footwell trim on the driver's side.
- Remove the lower instrument panel trim on the driver's side.
- Remove the lateral footwell trim on the left-hand centre console.
- Remove the radio.
- Remove the trim of the A/C control panel.
- Loosen the A/C control panel.

### Heater

- Remove years that do not apply from the type and duplicate label.
- Attach the duplicate label (type label) in the appropriate place in the engine compartment.

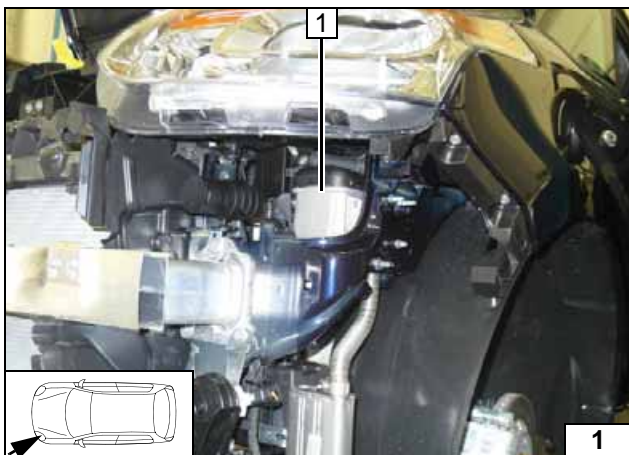

### Heater Installation Location

1 Heater

Installation location

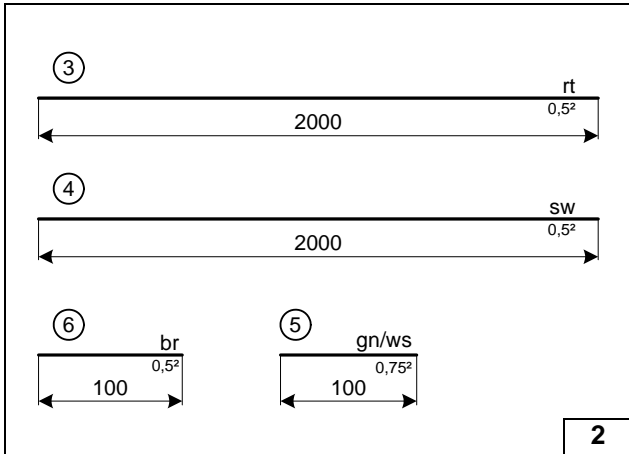
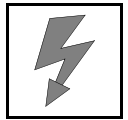

### Preparing Electrical System

Wire sections retain their numbering throughout the entire document.



### Cutting wires to length

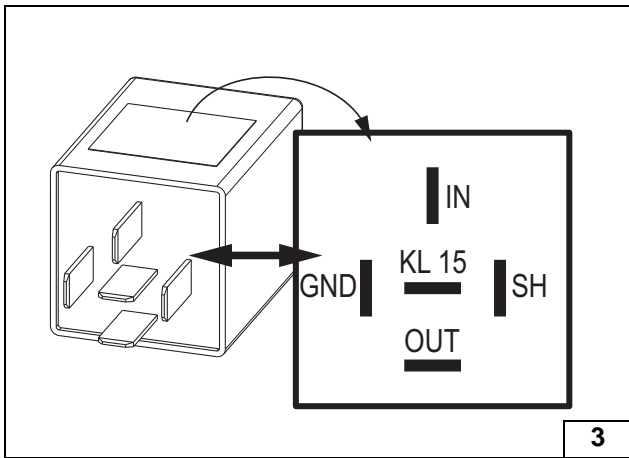

Check the PWM Gateway settings when starting up the heater and adjust if necessary.

Settings:

- Duty cycle: 100%
- Frequency: DC
- Voltage: 3.3V
- Function: High side



### Preparing PWM Gateway

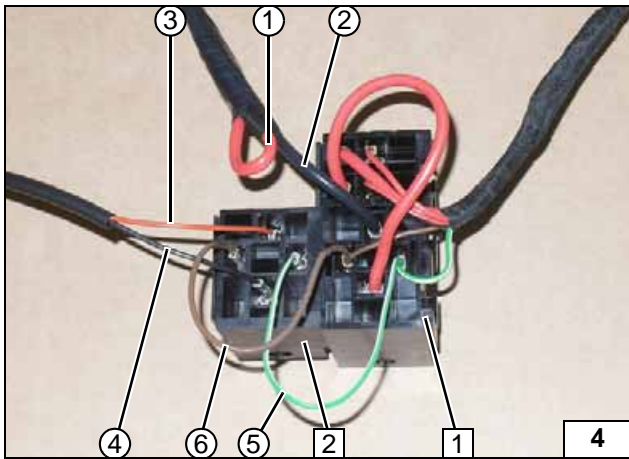

Interlock PWM GW socket 2 and passenger compartment relay and fuse holder 1. Connect wires according to the wiring diagram. Insulate red (rt) 4<sup>2</sup> wire 1 and tie back. Pull wires 3 and 4 into provided protective sleeving.



### Connecting wires

- 2 Black (sw) 4<sup>2</sup> wire of K1/30
- 3 Red (rt) wire of PWM GW/IN
- 4 Black (sw) wire of PWM GW/OUT
- 5 Green/white (gn/ws) wire of K1/86 and PWM GW/SH
- 6 Brown (br) wire of K1/85 and PWM GW/GND

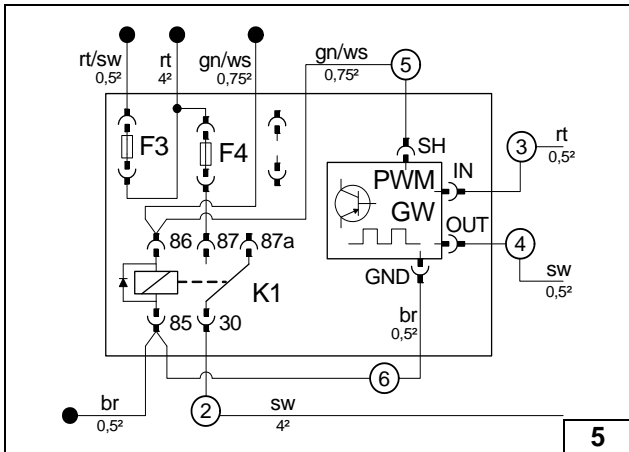

### Preparing K1 relay, PWM GW and F4

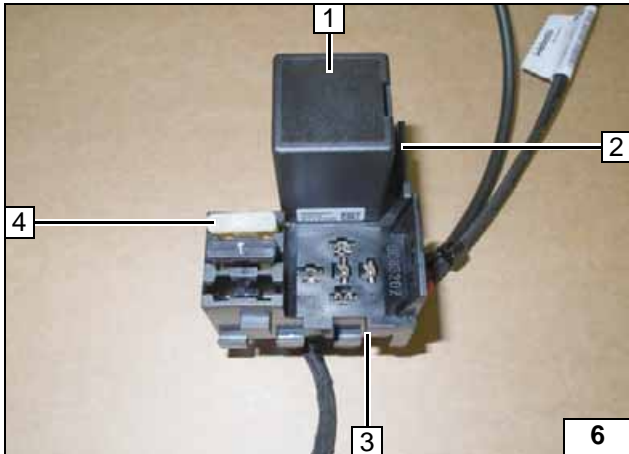
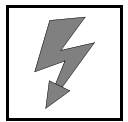

Insert PWM GW 1 and 25A fuse F4 4. K1 relay will only be inserted after installation.

- 1 PWM GW socket
- 2 Relay and fuse holder of passenger compartment



**Preparing K1 relay, PWM Gateway and F4**

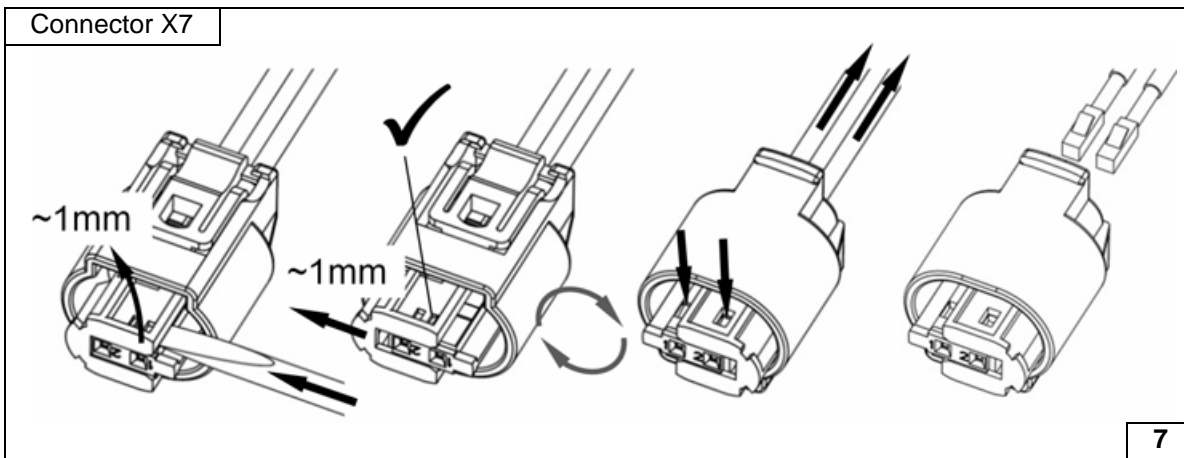

**Dismantling connector of metering pump**

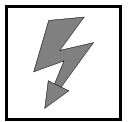

**Electrical System**

**Positive wire**

- 1 Positive wire on positive distributor

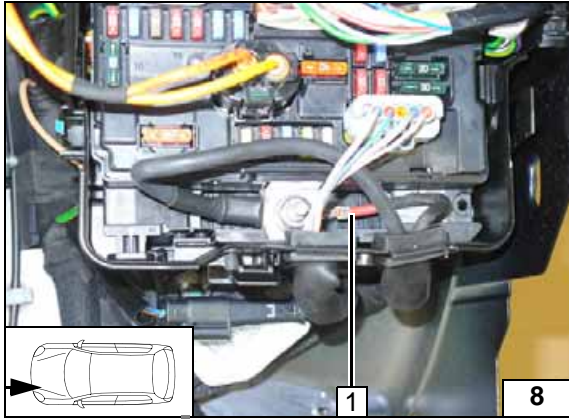

**Wiring harness routing**

- 1 Wiring harness of heater
- 2 Wiring harnesses of heater and heater control

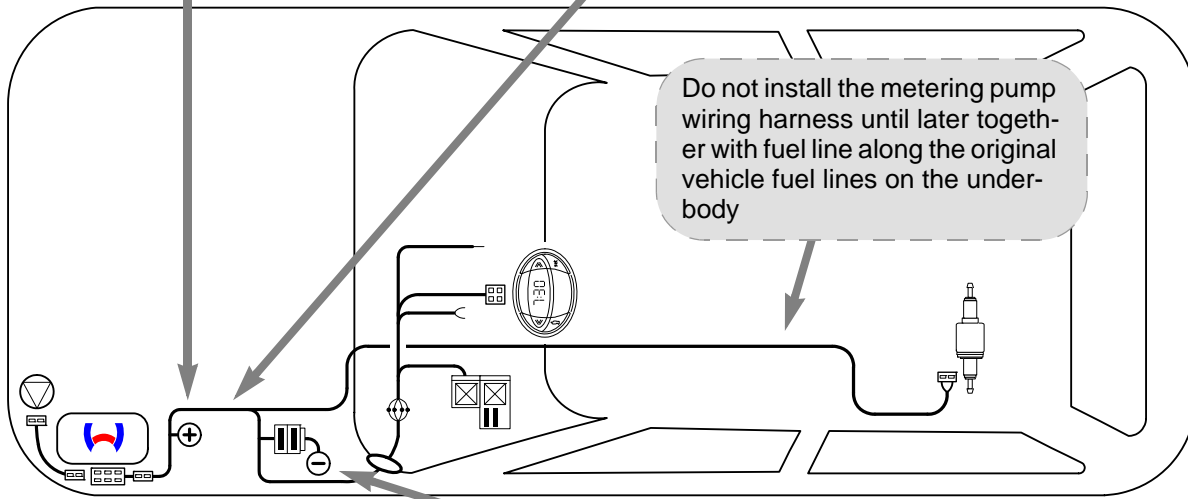
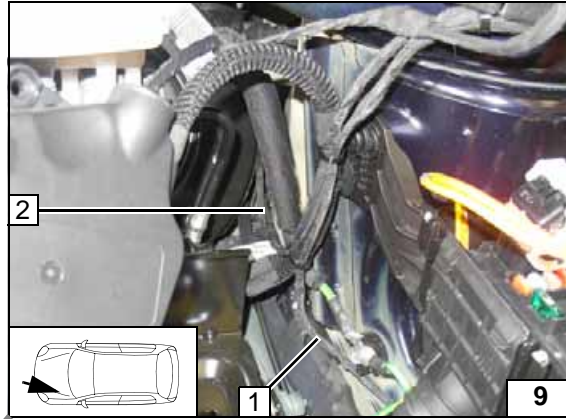

**Wiring harness routing diagram**

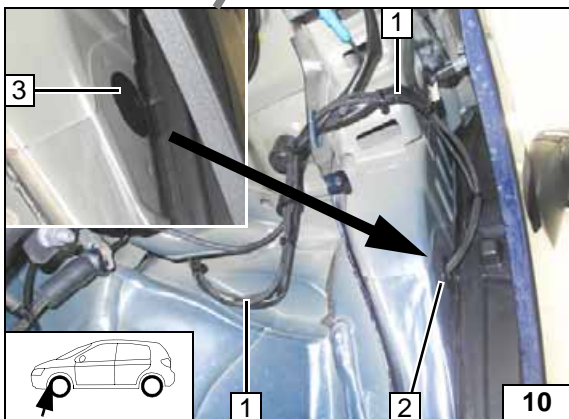

**Wiring harness routing**

Prior to installation of the protective rubber plug, remove sticker 3.

- 1 Wiring harnesses of heater and heater control
- 2 Insert protective rubber plug

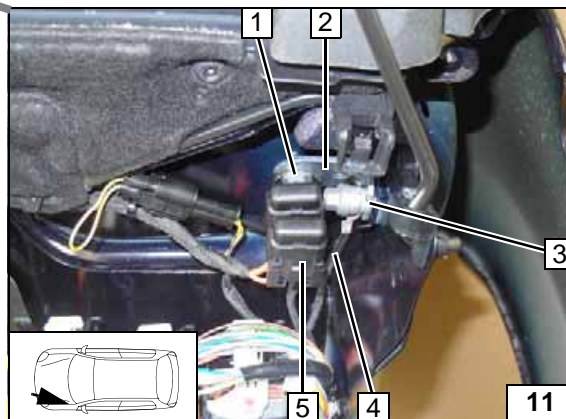

**Engine compartment fuse holder, earth wire**

- 1 M5x16 bolt, washer [2x], retaining plate of fuse holder, nut
- 2 Angle bracket
- 3 Original vehicle earth support point
- 4 Earth wire
- 5 F1-2 fuses



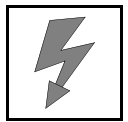

Fan Controller

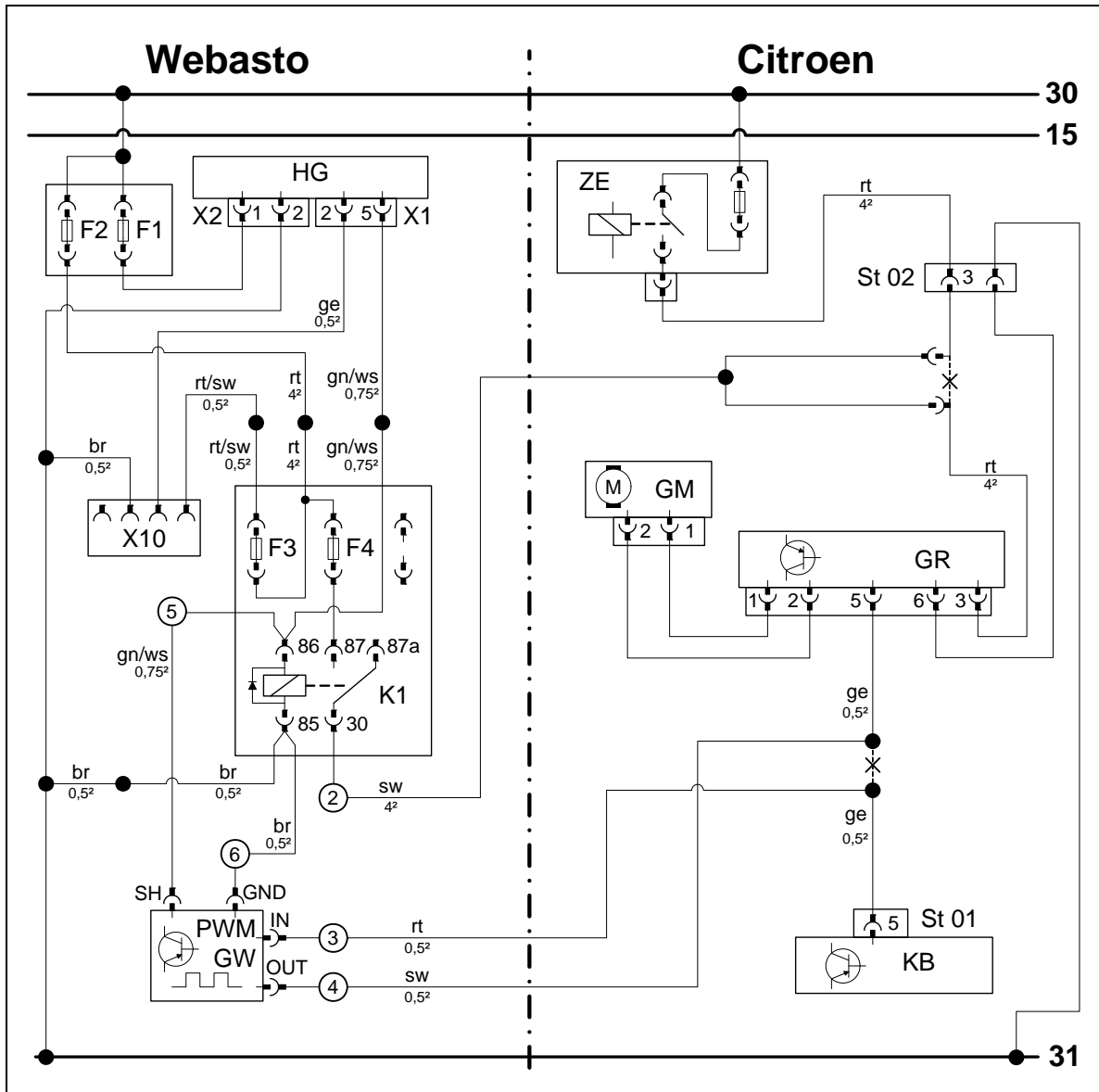

Wiring diagram

Webasto components		Vehicle components		Colours and symbols	
HG	TT-Evo heater	ZE	Central electrical box	rt	red
X1	6-pin heater connector	St 02	6-pin connector	sw	black
X2	2-pin heater connector			ge	yellow
F1	20A fuse	GM	Fan motor	gn	green
F2	30A fuse	GR	Fan controller	br	brown
X10	4-pin connector of heater control	St 01	6-pin connector KB	ws	white
F3	1A fuse	KB	A/C control panel		
F4	25A fuse				
K1	Fan relay				
PWM / GW	Pulse width modulator / PWM Gateway				
<b>Settings of PWM GW:</b>					
Duty cycle: 100%					
Frequency: DC					
Voltage: 3.3V				X	Cutting point
Function: High side				Wiring colours may vary.	

Legend

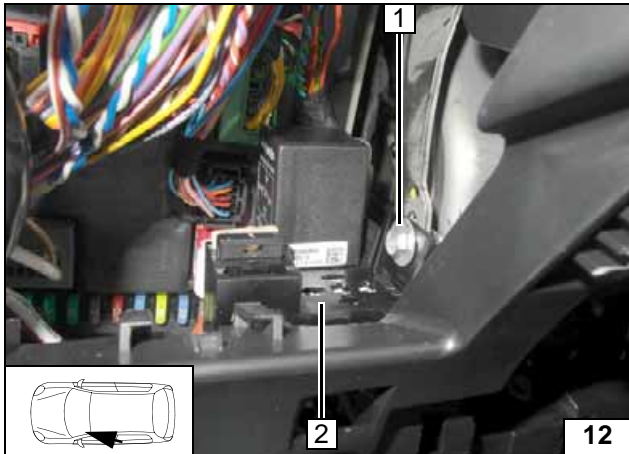

- 1 M5x16 bolt, large diameter washer [2x], nut, existing hole
- 2 Relay and fuse holder of passenger compartment

**Mounting passenger compartment relay and fuse holder**

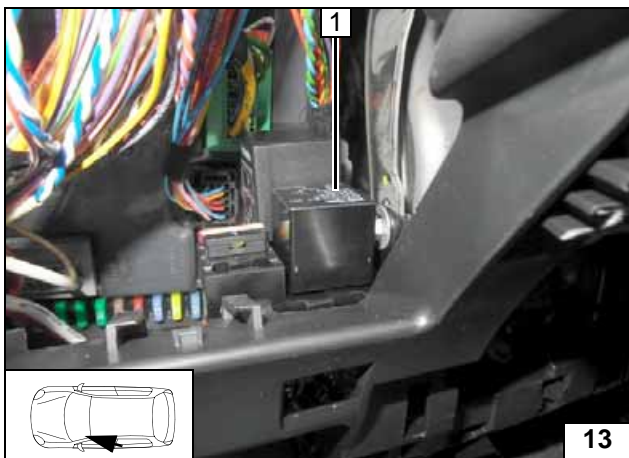

- 1 K1 relay

**Inserting K1-Relay**

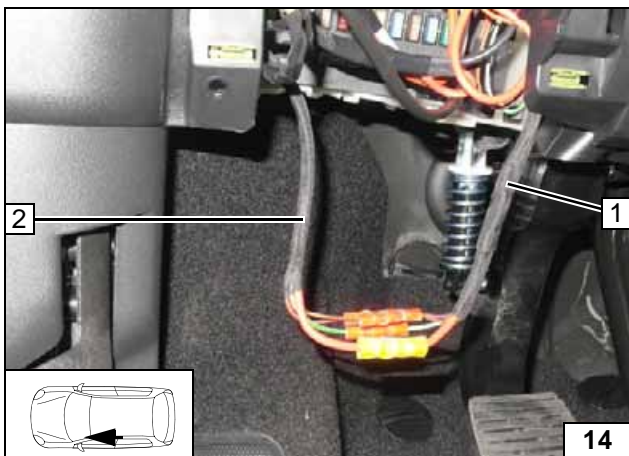

- 1 Wiring harness of passenger compartment relay and fuse holder
- 2 Wiring harness of heater

**Connecting wiring harnesses using same colour wires**

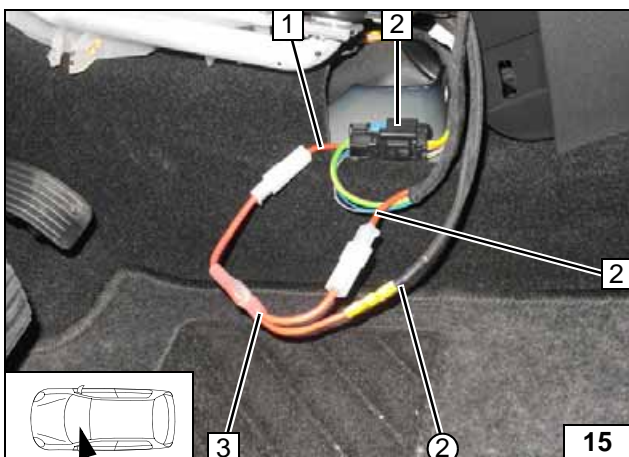

Connection on 6-pin connector St 02 2. Produce connections as shown in wiring diagram.

- 1 Red (rt) wire of 6-pin connector, pin 3
- 2 Red (rt) wire of fan controller
- 3 Y-adapter
- ② Black (sw) wire from K1/30

**Connecting fan controller**

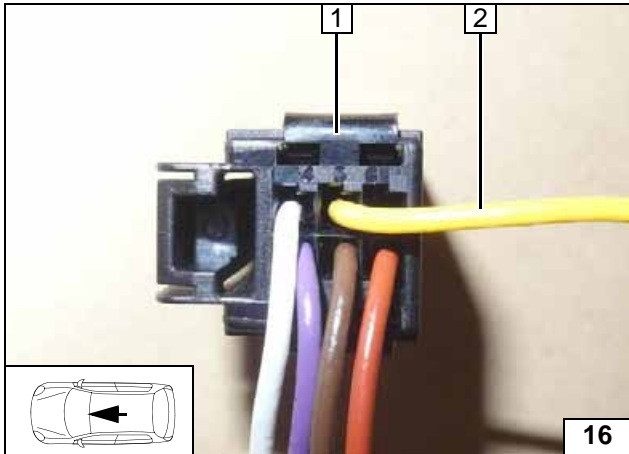

Connection to 6-pin connector St 01 1 from A/C control unit.

- 2 Yellow (ge) wire, Pin 5



**Connect-  
ing A/C  
control unit**

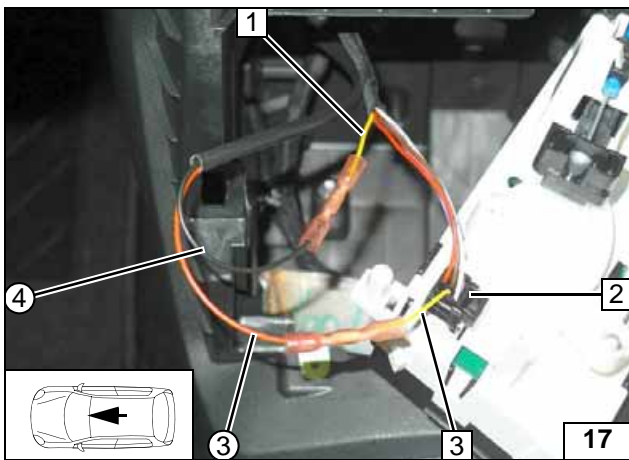

Produce connections as shown in wiring diagram.

- 1 Yellow (ge) wire of fan controller
- 2 6-pin connector of KB
- 3 Yellow (ge) wire of 6-pin connector, pin 5
- ③ Red (rt) wire of PWM GW/IN
- ④ Black (sw) wire of PWM GW/OUT



**Connect-  
ing A/C  
control unit**

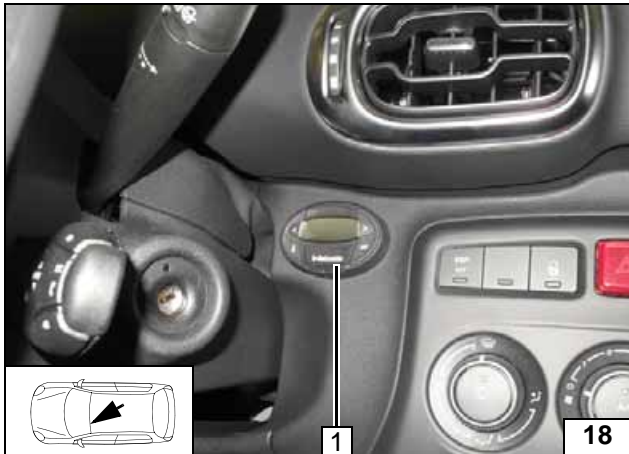

### Digital Timer

- 1 Digital timer



Installing digital timer

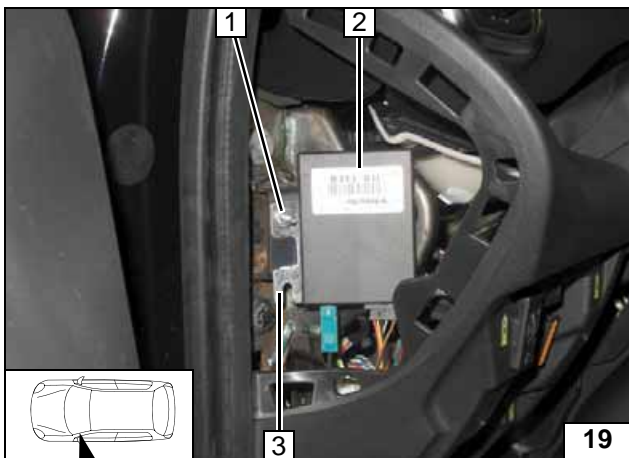

### Remote Option (Telestart)

- 1 M5x16 bolt, large diameter washer, flanged nut, existing hole
- 2 Receiver
- 3 Bracket



Installing receiver

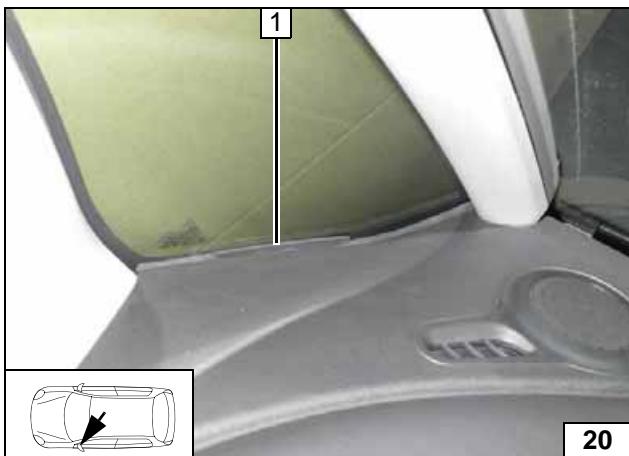

- 1 Antenna

Installing antenna

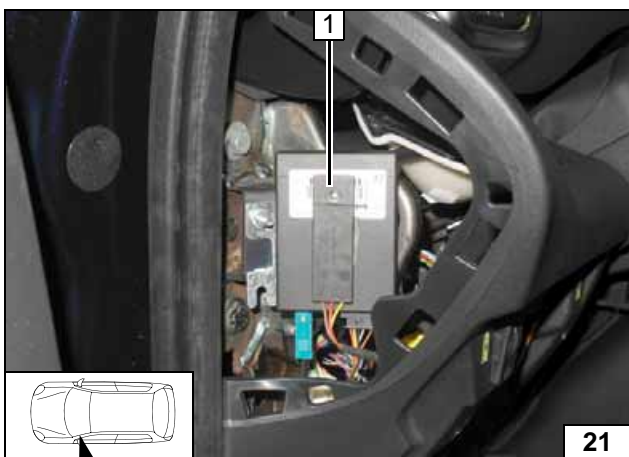

### Temperature sensor T100 HTM

Fasten temperature sensor 1 with adhesive tape.



Installing temperature sensor



### Remote Option (Thermo Call)

- 1 Receiver
- 2 M5x16 bolt, large diameter washer, flanged nut, existing hole

**Installing receiver**

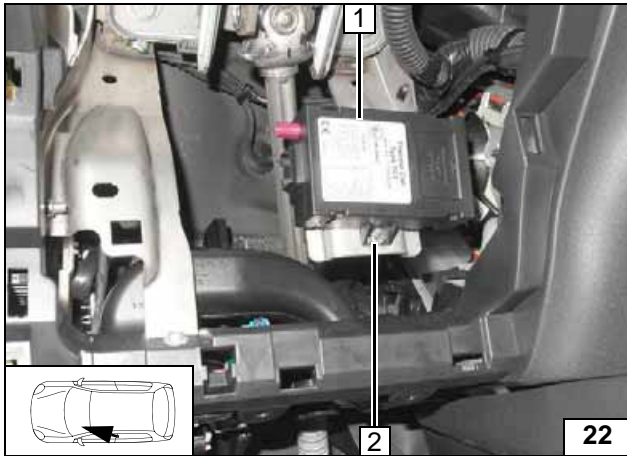

- 1 Antenna

**Installing antenna**

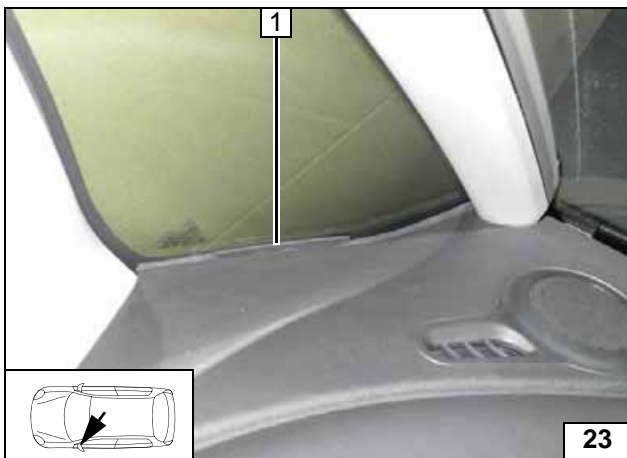

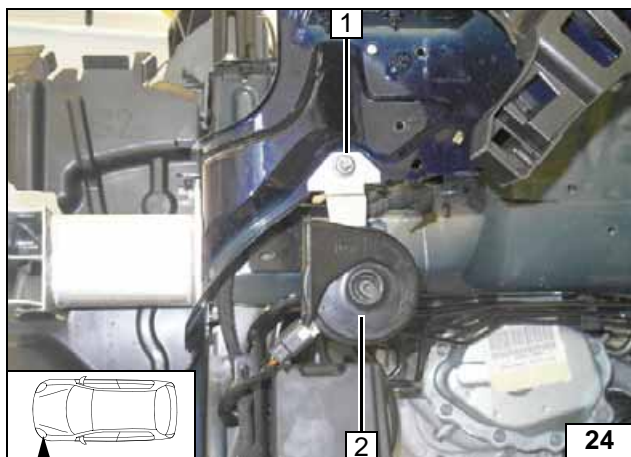

### Preparing Installation Location

Horn depends on equipment version.

#### Version 1:

- 1 Original vehicle bolt, discard flanged nut
- 2 Horn with bracket

Removing horn

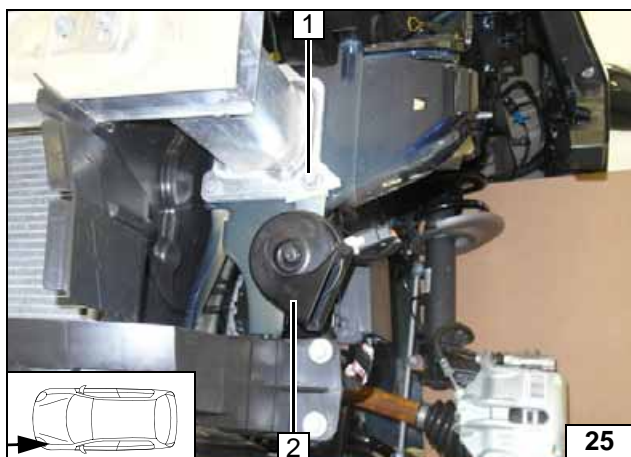

- 1 Original vehicle bolt
- 2 Horn with bracket

Installing horn

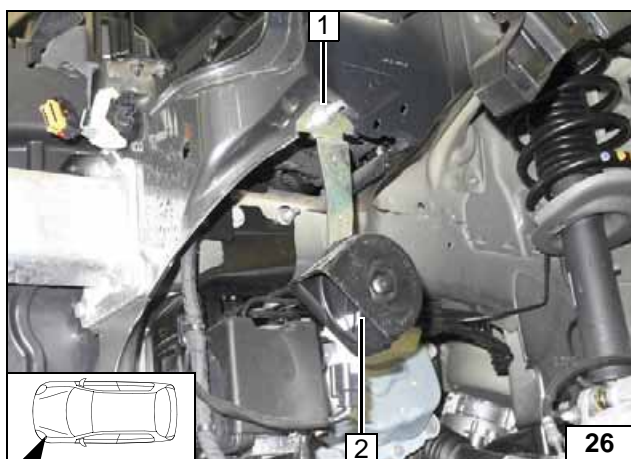

#### Version 2:

- 1 Original vehicle bolt, discard flanged nut
- 2 Horn with bracket

Removing horn

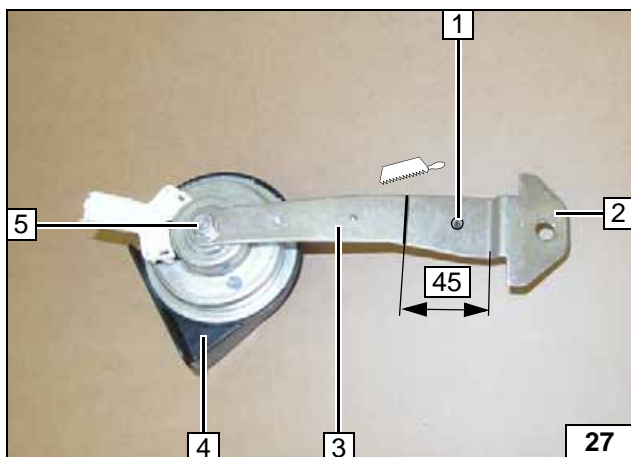

- 1 7 mm dia. hole
- 2 Bracket
- 3 Discard section
- 4 Remove horn, clip will be reused
- 5 Original vehicle nut, will be reused.

Preparing horn

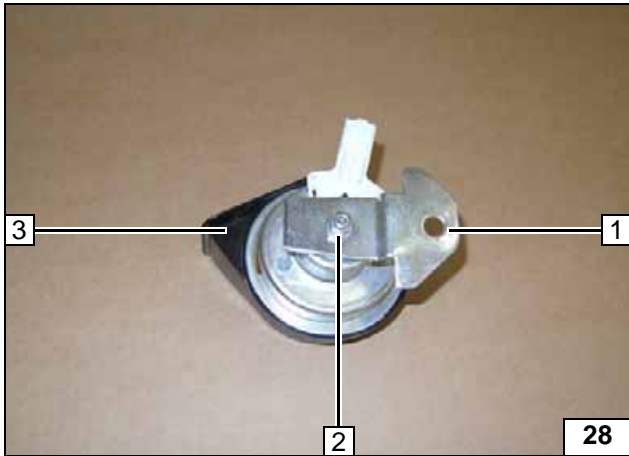

- 1 Bracket
- 2 Original vehicle nut
- 3 Install horn

Premounting horn

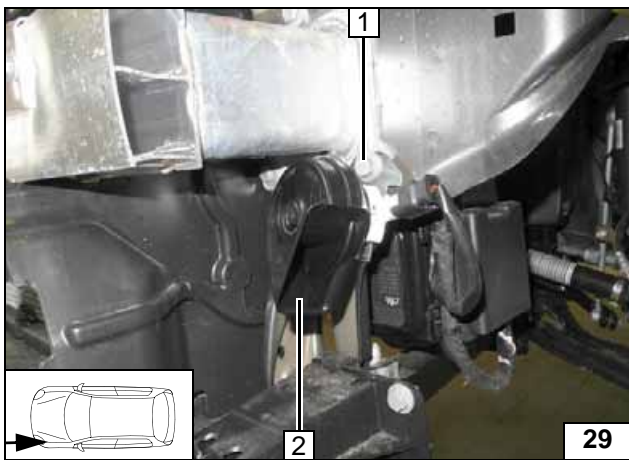

- 1 Original vehicle bolt
- 2 Horn with bracket

Installing horn

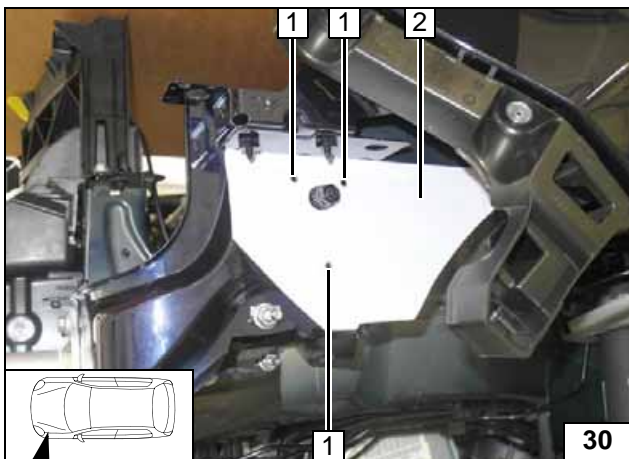

All vehicles

Cut out template 2 and apply as shown.

- 1 Copy hole pattern [3x]



Copying hole pattern

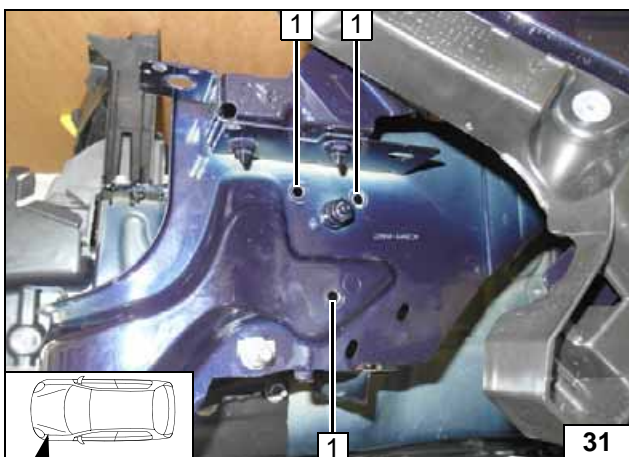

- 1 7mm dia. hole [3x]

Holes in body

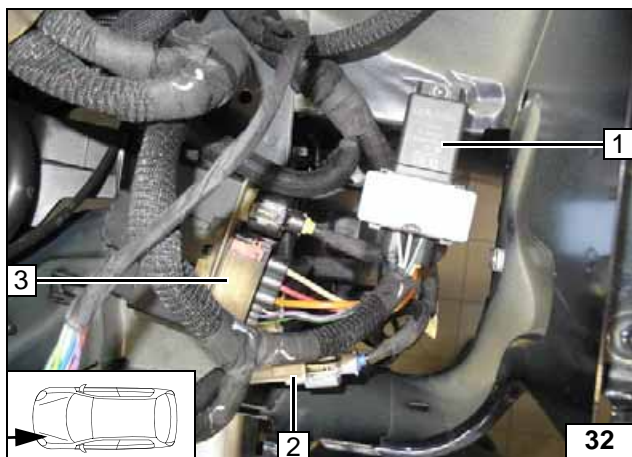

**Diesel only**

- 1 Remove relay
- 2 Pull off connector
- 3 Remove control unit

Removing relay and control unit

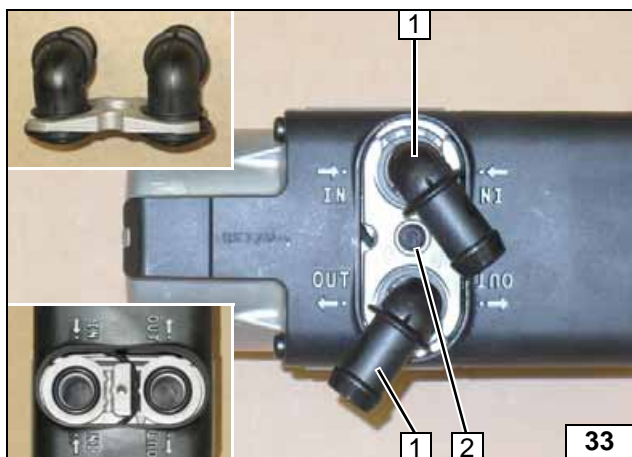

**Preparing Heater**

- 1 Water connection piece, sealing ring [2x each]
- 2 5x15 self-tapping bolt, retaining plate of water connection pieces



Installing water connection pieces

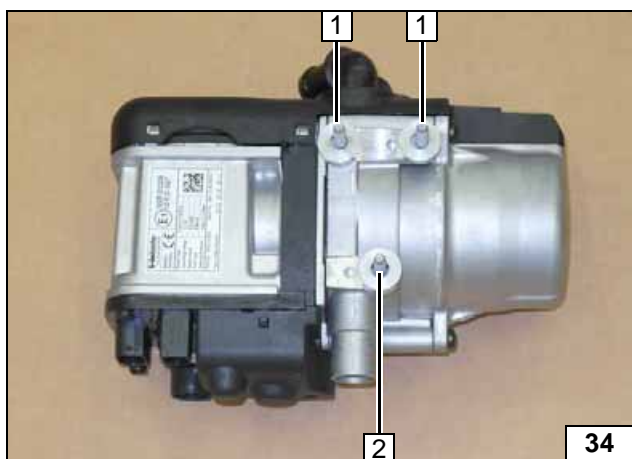

- 1 Stud bolt, 5mm shim [2x each]
- 2 Stud bolt, 10mm shim

Premounting heater

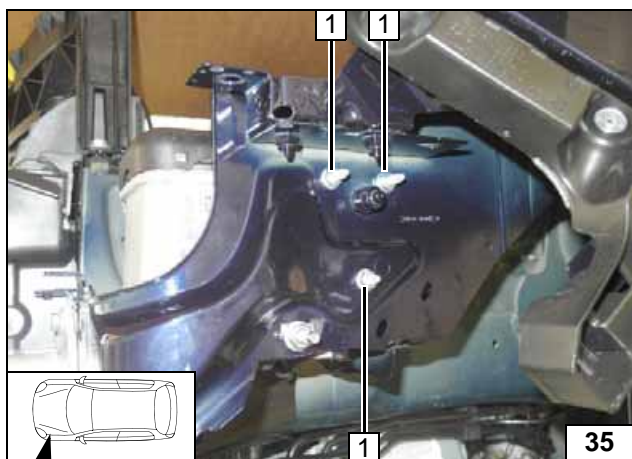

**Installing Heater**

- 1 M6 flanged nut [3x]

Installing heater



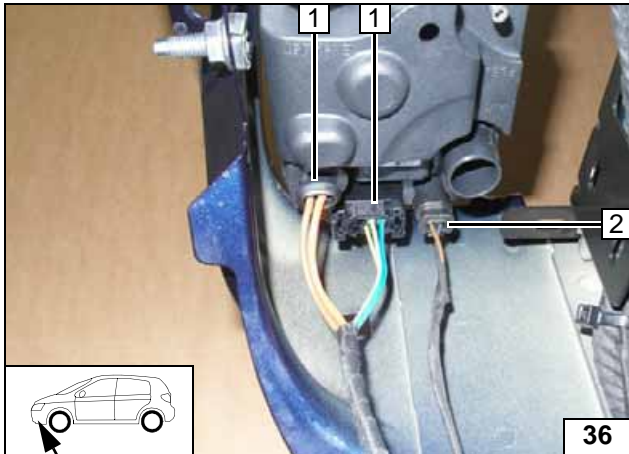

- 1 Wiring harness of heater [2x]
- 2 Wiring harness of circulating pump

Installing wiring harnesses

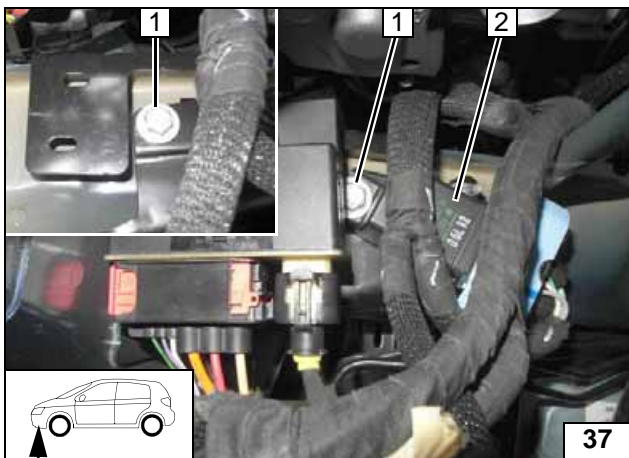

**Diesel only**

Drill out tab of relay 2 at position 1 to 8.5mm dia.

- 1 Original vehicle bolt



Installing relay

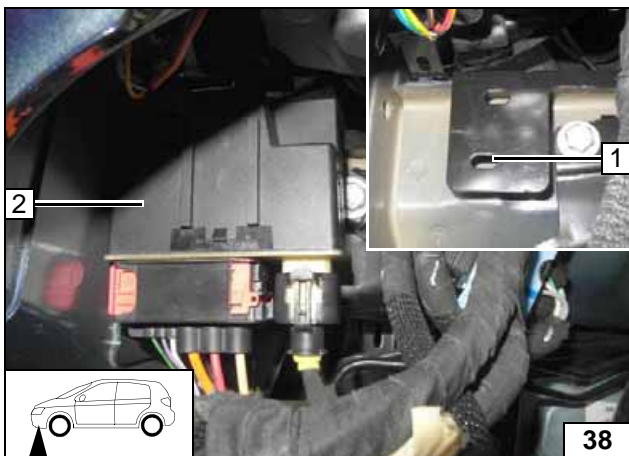

Insert control unit 2 into lower hole of bracket 1 and complete it with the connector.



Installing the control unit



Tie away wiring harnesses with cable tie 1.



Fastening wiring harnesses

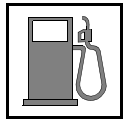

**Fuel**

**CAUTION!**

Open the vehicle's fuel tank cap, ventilate the tank and then re-close the tank lock.

Catch any fuel running off in an appropriate container.

Install fuel line and metering pump wiring harness so that they are protected against stone impact. Unless specified otherwise, always fasten using cable ties. Provide rub protection for fuel line and wiring harness in areas where there are sharp edges.

**WARNING!**

The fuel line and wiring harness are routed to the metering pump as shown in the wiring harness routing diagram.

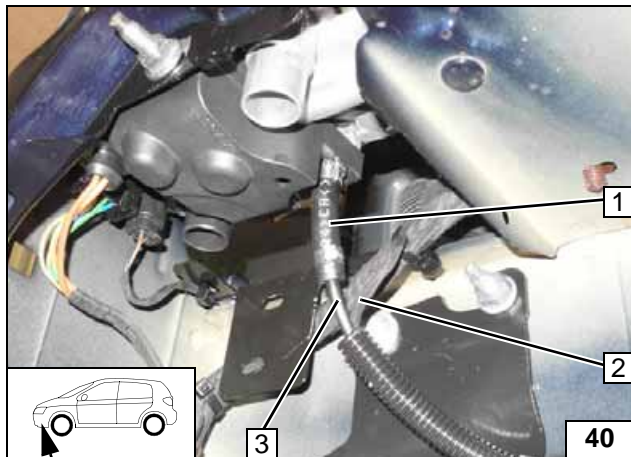

Pull fuel line **3** and wiring harness of metering pump **2** into 10mm dia. corrugated tube.

- 1 Hose section, 10mm dia.clamp [2x]

**Connect-  
ing heater**

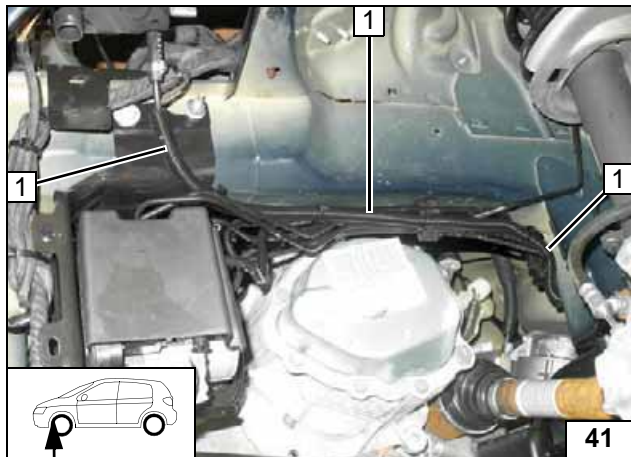

- 1 Fuel line and metering pump wiring harness in 10mm dia. corrugated tube (with cable tie on brake line)

**Routing  
lines**

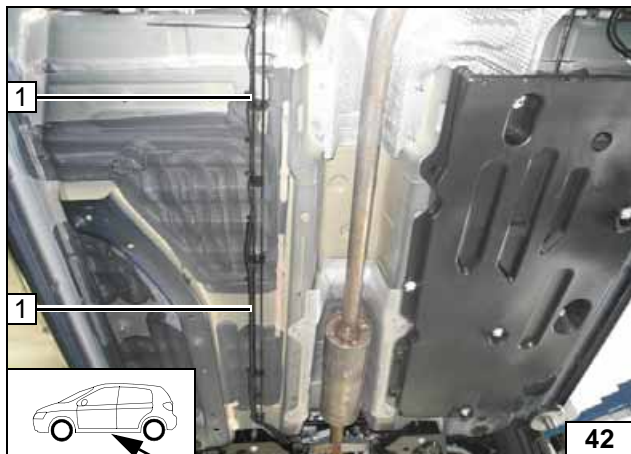

- 1 Fuel line and metering pump wiring harness in 10mm dia. corrugated tube (with cable tie on brake line)

**Routing  
lines**

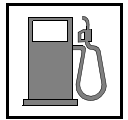

Preparing perforated bracket

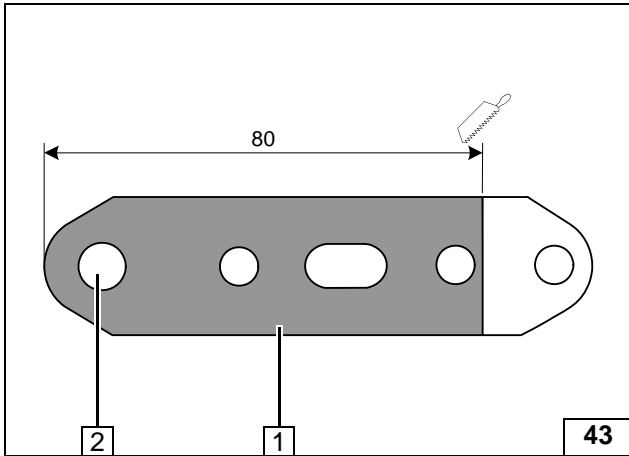

- 1 Perforated bracket
- 2 Drill out 8.5 mm dia. hole

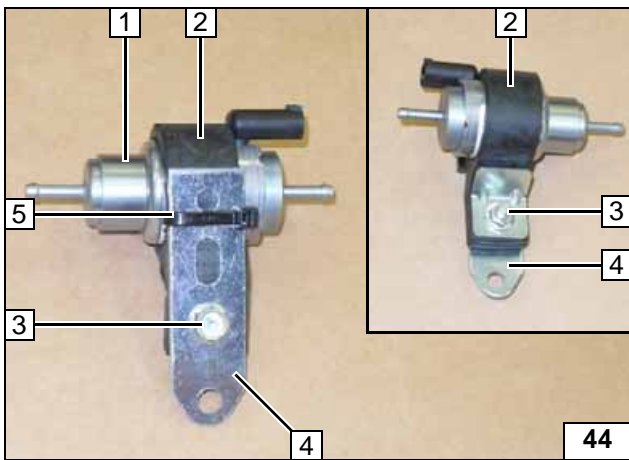

- 1 Metering pump
- 2 Mounting of metering pump
- 3 M6x25 bolt, support angle bracket, flanged nut
- 4 Perforated bracket
- 5 Cable tie

Premounting metering pump

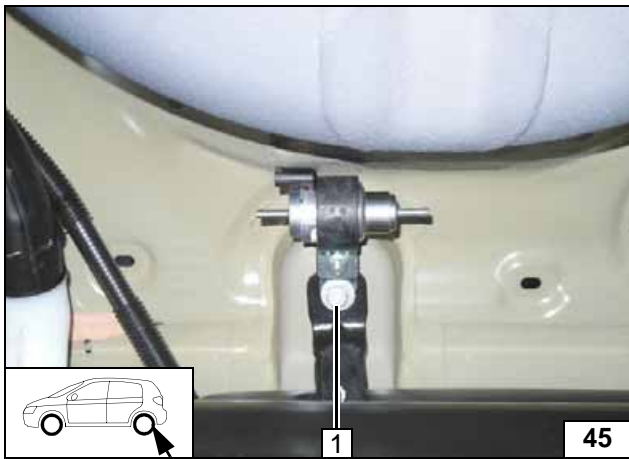

- 1 Perforated bracket on original vehicle bolt



Mounting metering pump

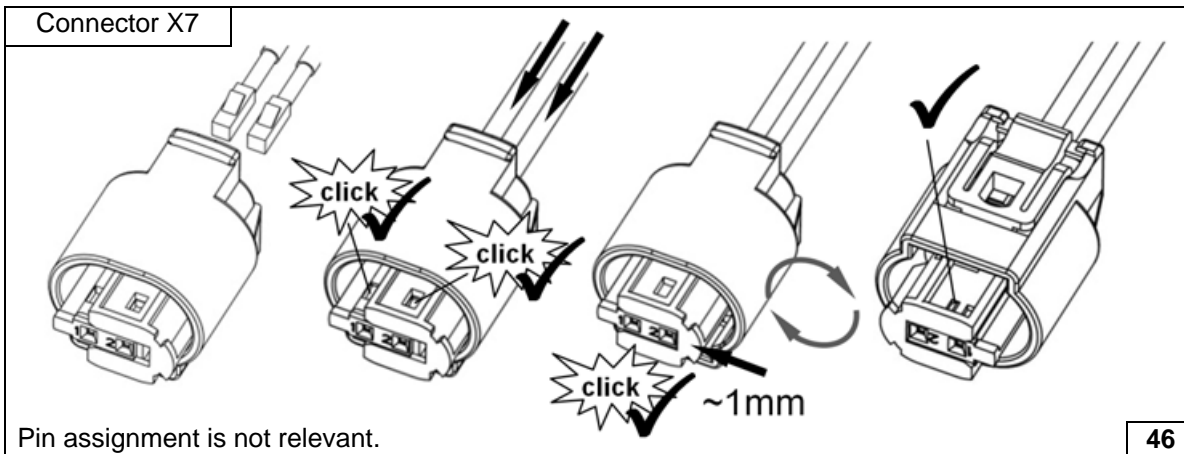

Completing connector of metering pump

Pin assignment is not relevant.

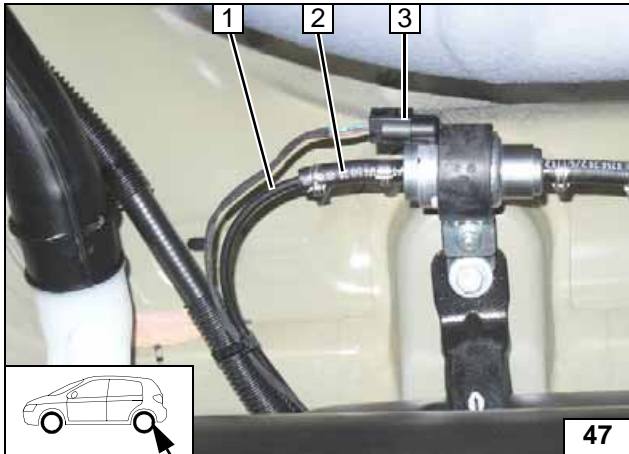

- 1 Fuel line of heater
- 2 Hose section, 10mm dia.clamp [2x]
- 3 Wiring harness of metering pump, connector X7 mounted

Connect-  
ing meter-  
ing pump

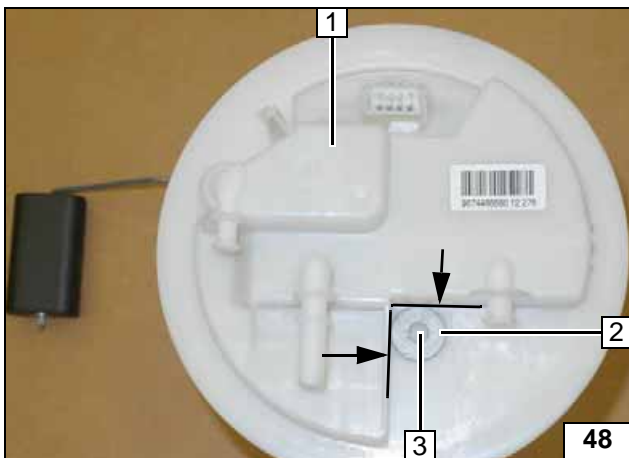

**Petrol**

Remove fuel-tank sending unit **1** in accordance with the manufacturer's instructions. Place large diameter washer with outer dia.  $d_a = 21.6\text{mm}$  **2** on the markings.

- 3 Copy hole pattern, 6mm dia. hole



Fuel ex-  
traction



Shape fuel standpipe **1** according to template and cut it to length.



Installing  
fuel stand-  
pipe

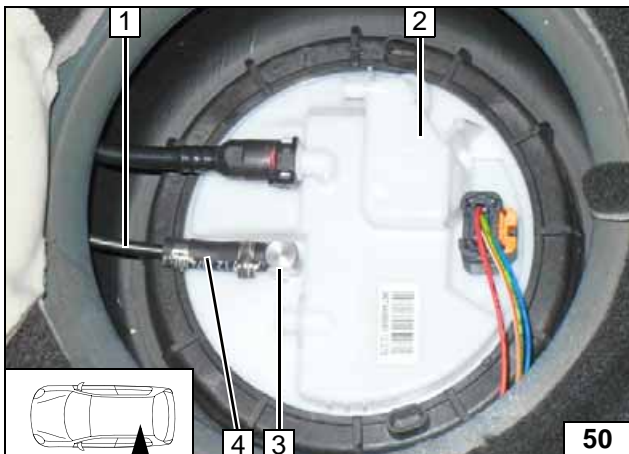

Install fuel-tank sending unit **2** in accordance with the manufacturer's instructions.

- 1 Fuel line
- 3 Fuel standpipe
- 4 Hose section, 10mm dia.clamp [2x]



Connect-  
ing fuel line

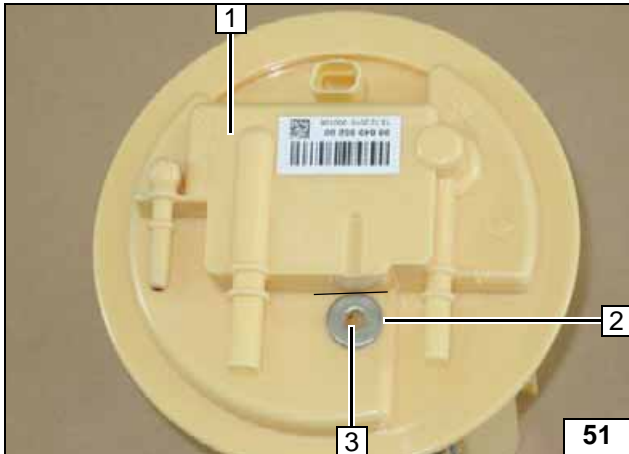
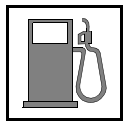

**Diesel**

Remove fuel-tank sending unit 1 in accordance with the manufacturer's instructions.

- 2 Position washer with outer dia.  $d_a = 18\text{mm}$  against the edges
- 3 Copy hole pattern, 6mm dia. hole



**Fuel extraction**



Shape fuel standpipe 1 according to template and cut it to length.



**Installing fuel standpipe**

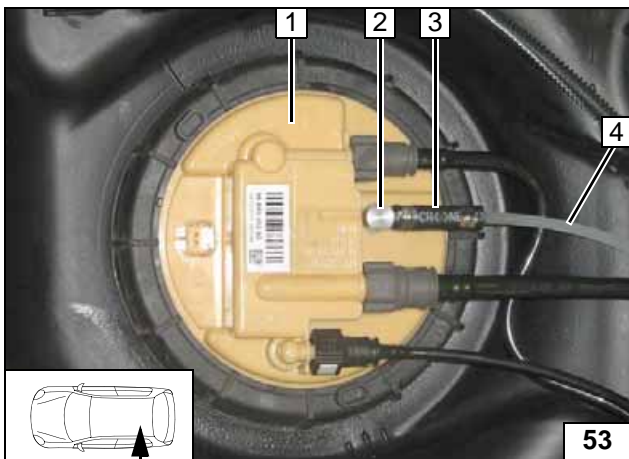

Install fuel-tank sending unit 1 in accordance with the manufacturer's instructions.

- 2 Fuel standpipe
- 3 Hose section, 10mm dia.clamp [2x]
- 4 Fuel line



**Connecting fuel line**

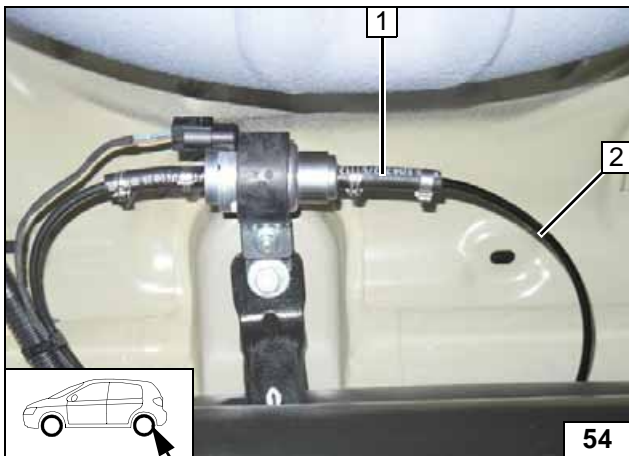

**All vehicles**

Check the position of the components; adjust if necessary. Check that they have freedom of movement.

- 1 Hose section, 10mm dia.clamp [2x]
- 2 Fuel line of fuel standpipe



**Connecting metering pump**

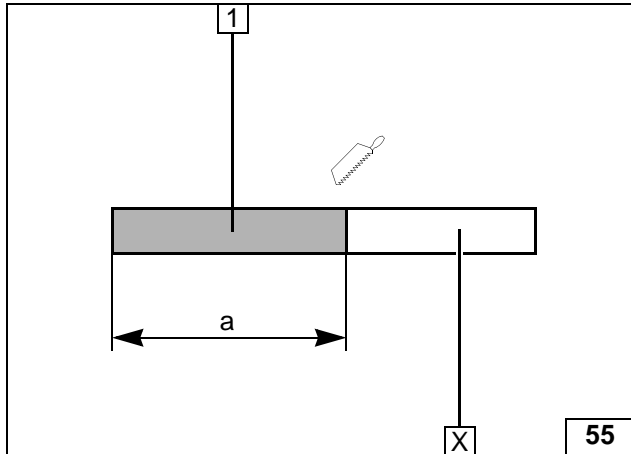
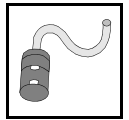

### Combustion Air

Discard section X.

- 1 Combustion air pipe  
a = 300

Cutting combustion air pipe to length

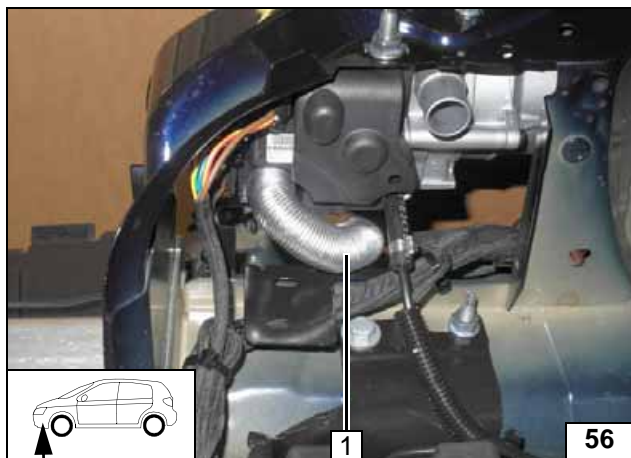

- 1 Combustion air pipe

Installing combustion air pipe

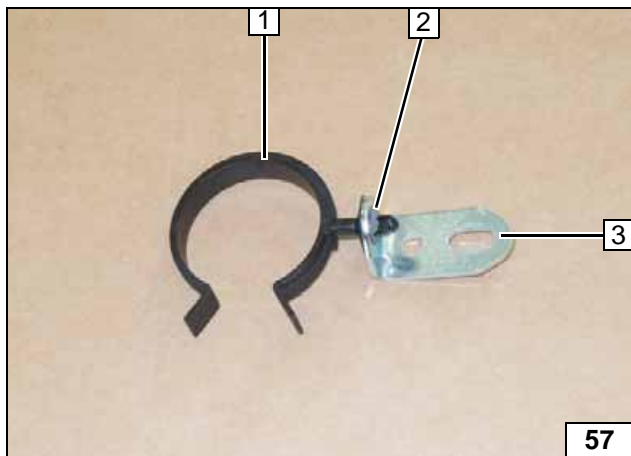

- 1 Retaining clip in hole
- 2 Pin lock
- 3 Angle bracket

Preparing angle bracket

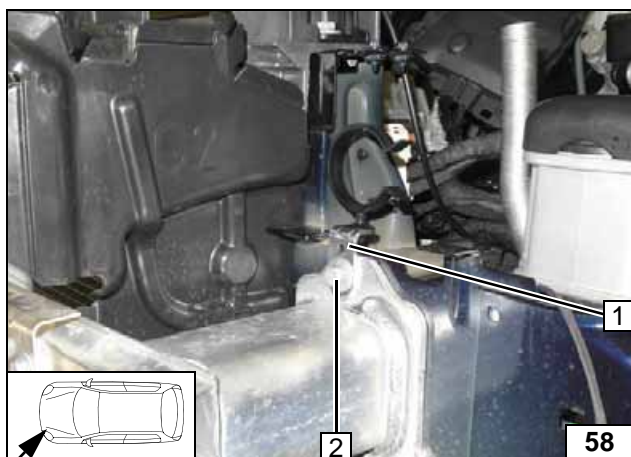

- 1 Angle bracket
- 2 Original vehicle bolt

Installing angle bracket

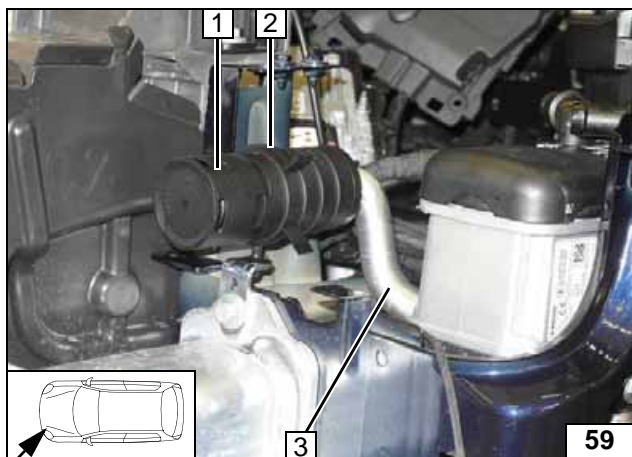
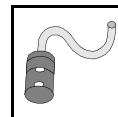

- 1 Silencer
- 2 Retaining clip
- 3 Combustion air pipe



**Installing  
silencer**

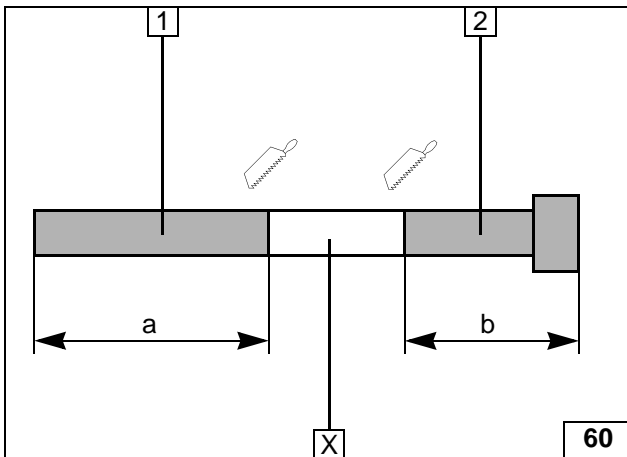
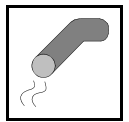

**Exhaust Gas**

Discard section X.

- 1 Exhaust pipe  
a = 230
- 2 Exhaust end section  
b = 50



**Preparing exhaust pipe**

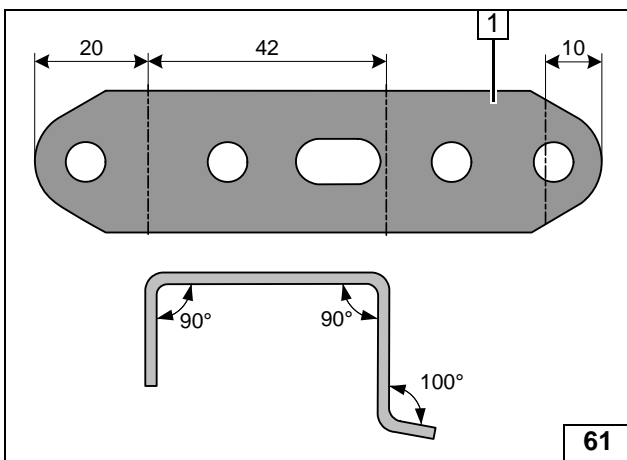

- 1 Perforated bracket



**Preparing perforated bracket**

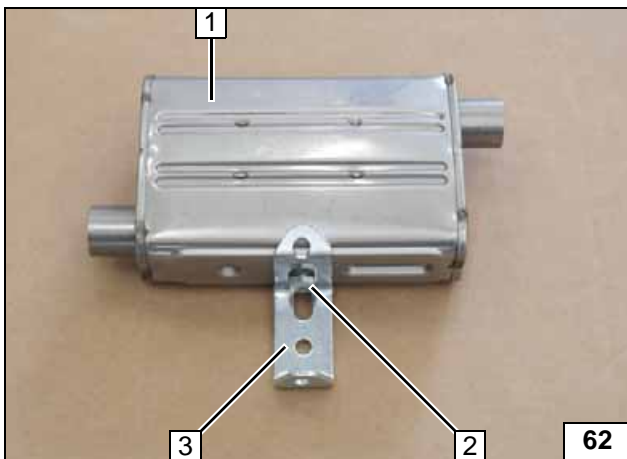

- 1 Silencer
- 2 M6x16 bolt, spring lockwasher
- 3 Perforated bracket

**Premounting silencer**

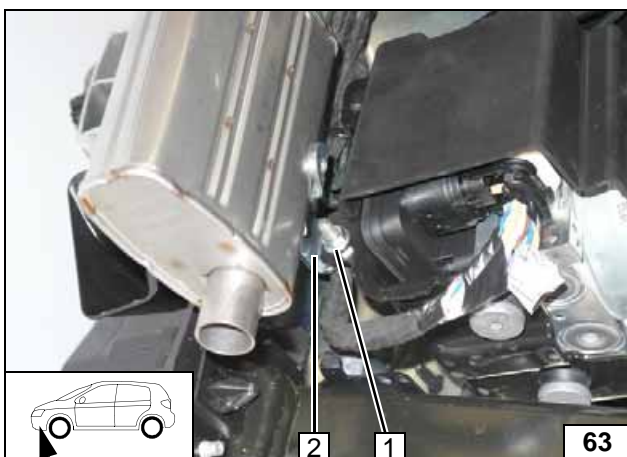

Unclip the original vehicle wiring harness at position 1 and secure it with cable ties.

- 1 M6x20 bolt, flanged nut, existing hole of ABS bracket
- 2 Perforated bracket



**Installing silencer**



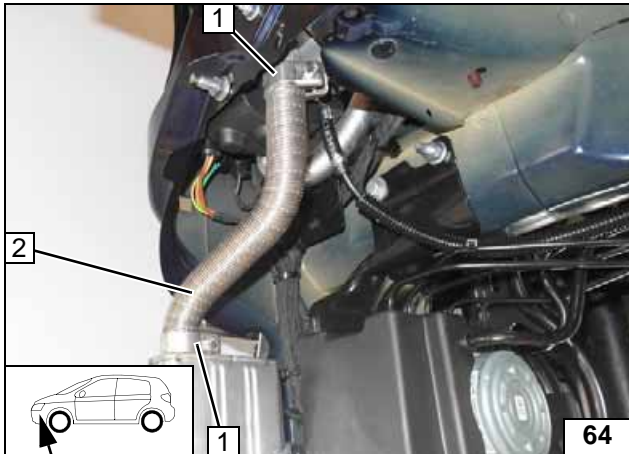
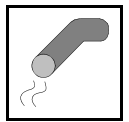

- 1 Hose clamp [2x]
- 2 Exhaust pipe

Installing exhaust pipe

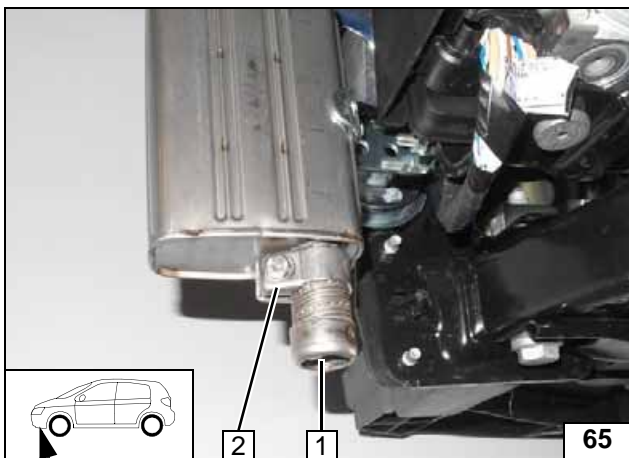

Ensure sufficient distance to neighbouring components; correct if necessary.

- 1 Exhaust end section
- 2 Hose clamp



Installing exhaust end section

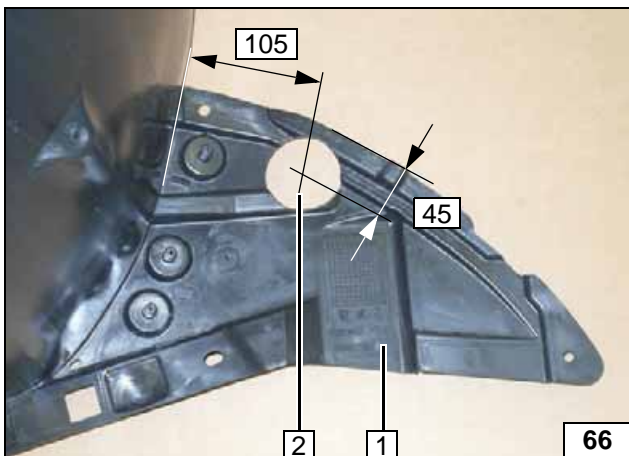

- 1 Wheel well trim
- 2 60 mm dia. hole



Cutting out wheel well trim





### Coolant Circuit

**WARNING!**

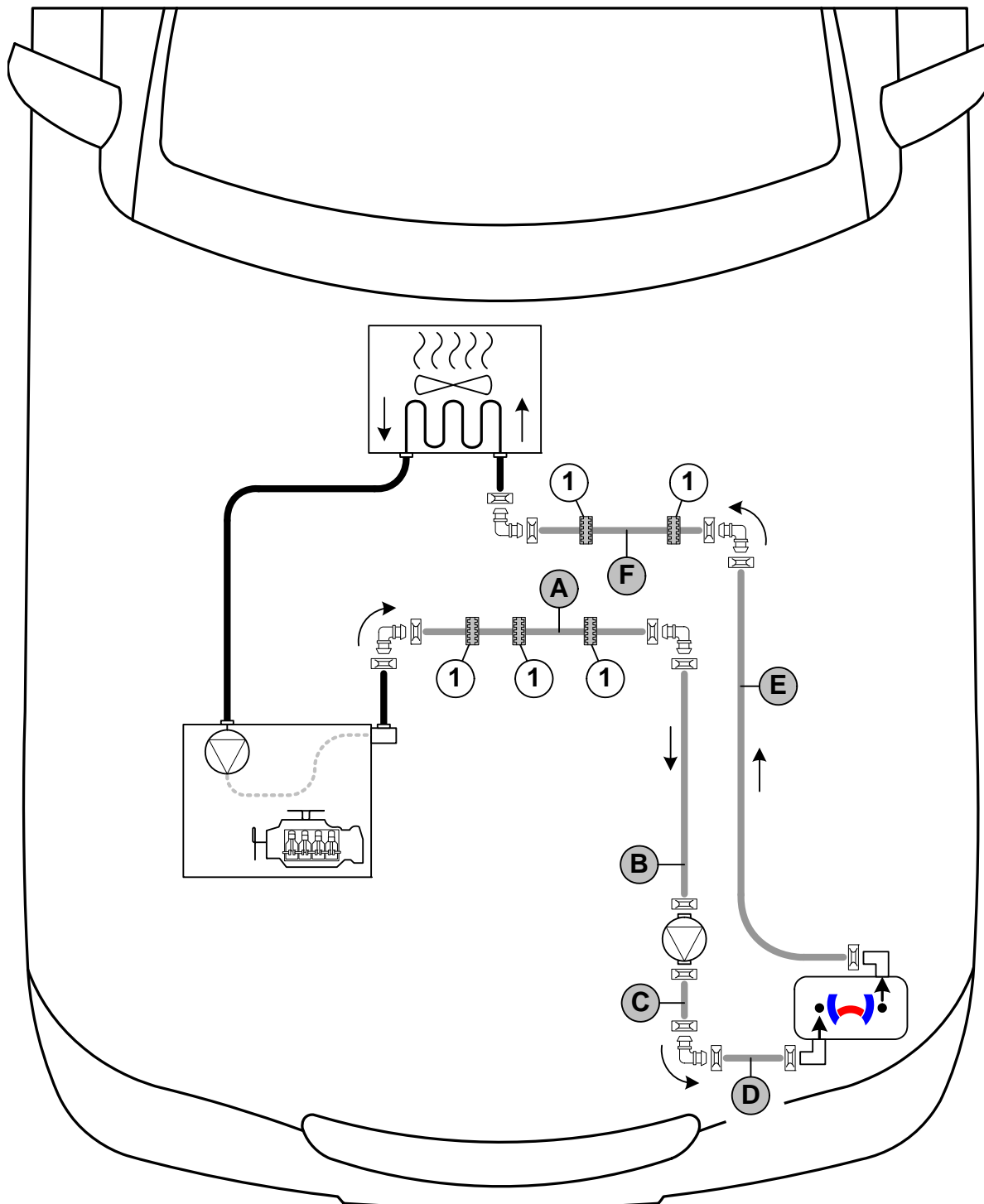
Any coolant running off should be collected in an appropriate container. Route hoses so that they are kink-free. Unless specified otherwise, always fasten using cable ties. Position clamps so that other hoses cannot be damaged. When installing the hoses, the heater must be filled with coolant. The connection should be "inline" based on the following diagram:



Hose routing diagram

All connecting pipes without a specific designation  = 25mm dia.  
 1 = Black (sw) rubber isolator .  
 All connecting pipes  = 18x18mm dia.



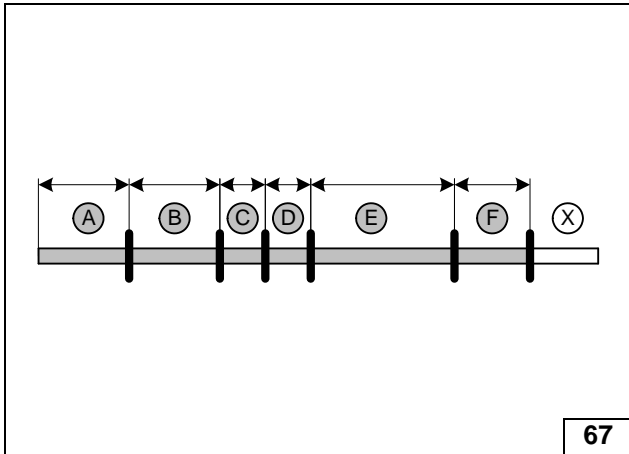

Discard section X.

- A = 220
- B = 490
- C = 60
- D = 80
- E = 510
- F = 250



**Cutting hoses to length**

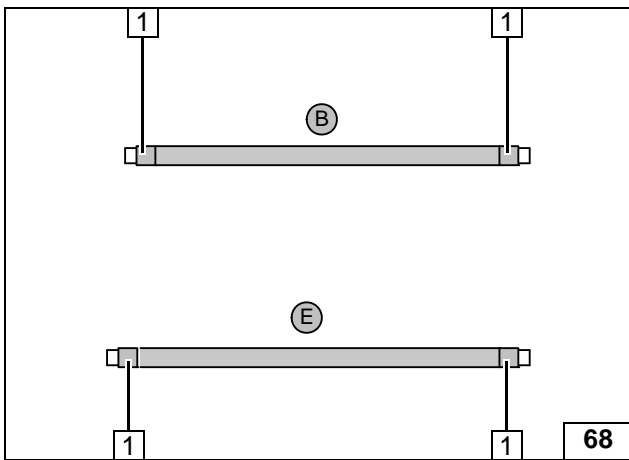

Push braided protection hoses onto hoses B and E and cut to length. Cut heat shrink plastic tubing to size.

- 1 50 mm long heat shrink plastic tubing [4x]



**Preparing hoses**

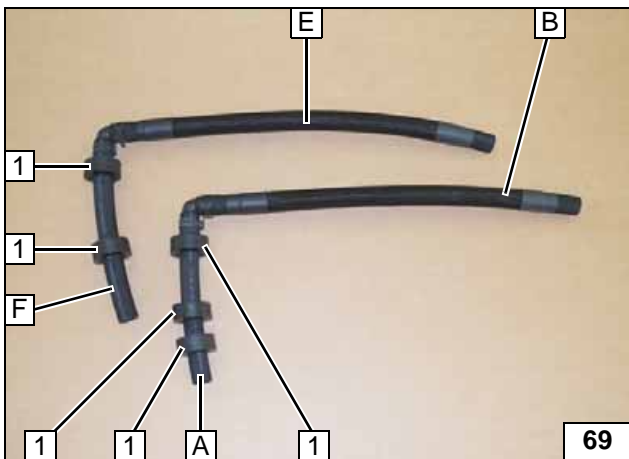

- 1 Slide on black (sw) rubber isolator [5x]

**Preparing hoses**

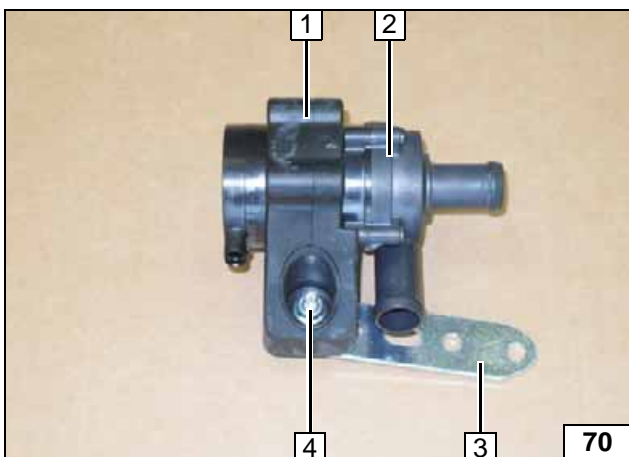

- 1 Circulating pump mounting
- 2 Circulating pump
- 3 Perforated bracket
- 4 M6x25 bolt, flanged nut

**Premounting circulating pump**

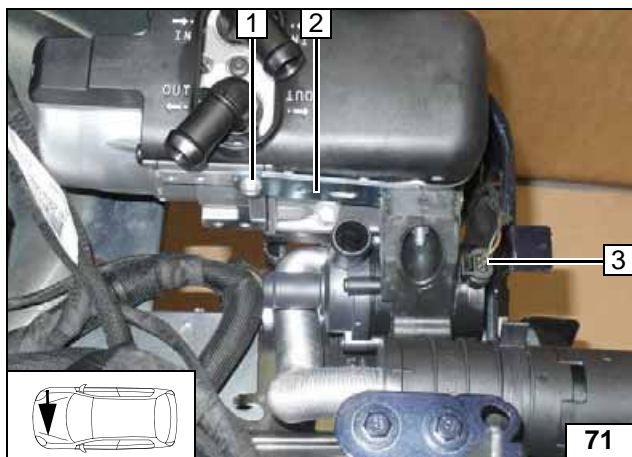

- 1 5x13 self-tapping bolt
- 2 Perforated bracket
- 3 Mount wiring harness of circulating pump

**Mounting circulating pump**

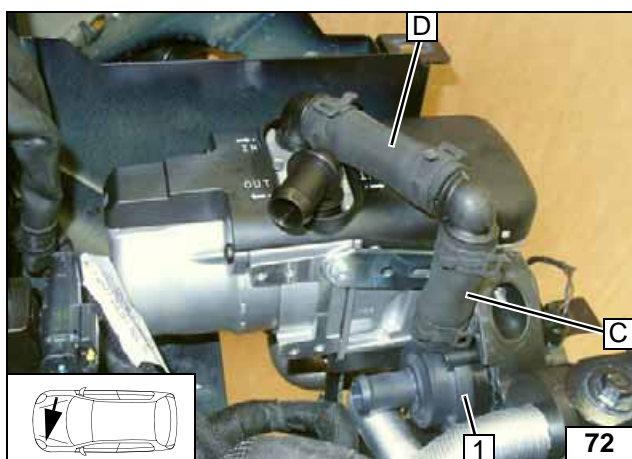

- 1 Circulating pump

**Connection of heater inlet**

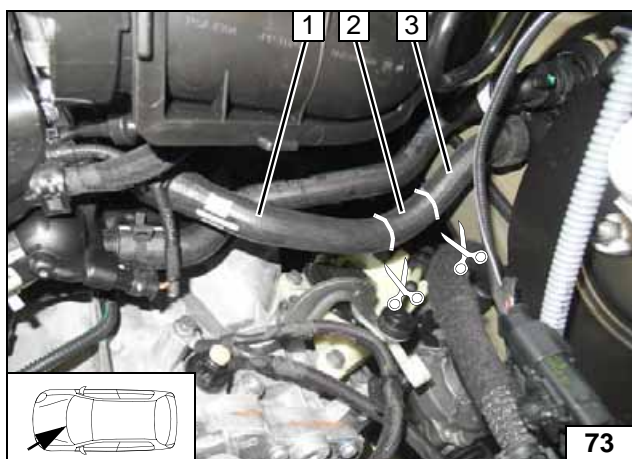

Figure shows petrol vehicle.  
Cut off hose on engine outlet/heat exchanger inlet at markings.

- 1 Hose section of engine outlet
- 2 Discard section
- 3 Hose section of heat exchanger inlet

**Cutting point**

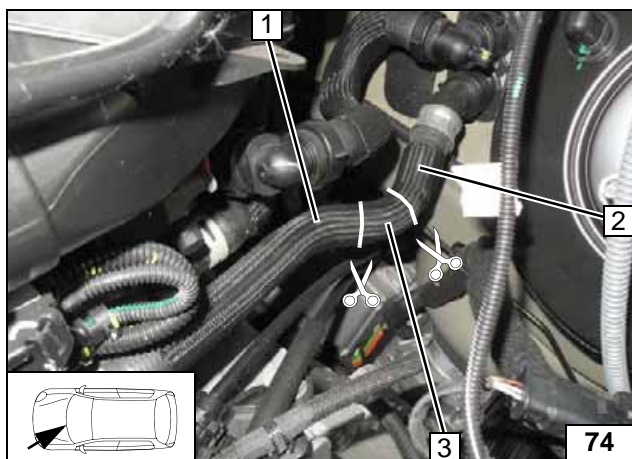
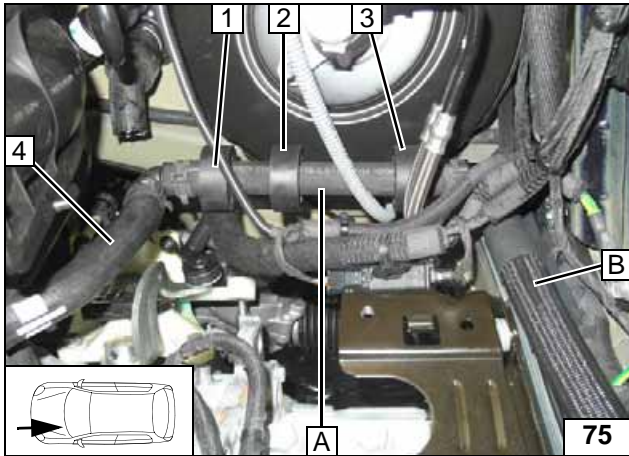

Figure shows diesel vehicle.  
Remove braided protection hose on hose of engine outlet / heat exchanger inlet Cut off hose on engine outlet/heat exchanger inlet at markings.

- 1 Hose section of engine outlet
- 2 Hose section of heat exchanger inlet
- 3 Discard section

**Cutting point**





Align hoses. Ensure sufficient distance to neighbouring components; correct if necessary.

- 1 Align black (sw) rubber isolator with wiring harness
- 2 Align black (sw) rubber isolator with brake booster
- 3 Align black (sw) rubber isolator with brake line
- 4 Hose of engine outlet

**Connect-  
ing engine  
outlet**

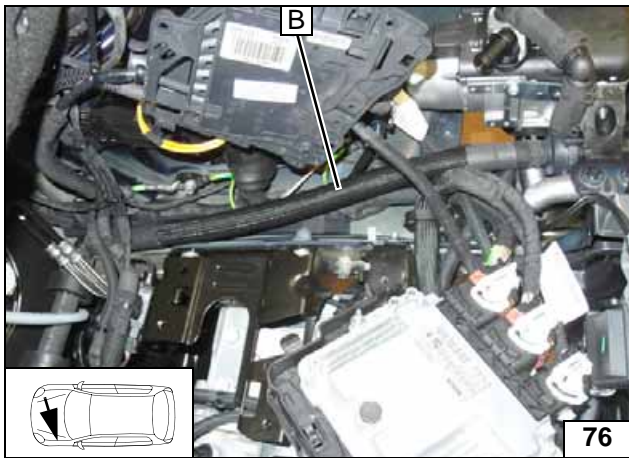

**Routing in  
engine  
compartment**

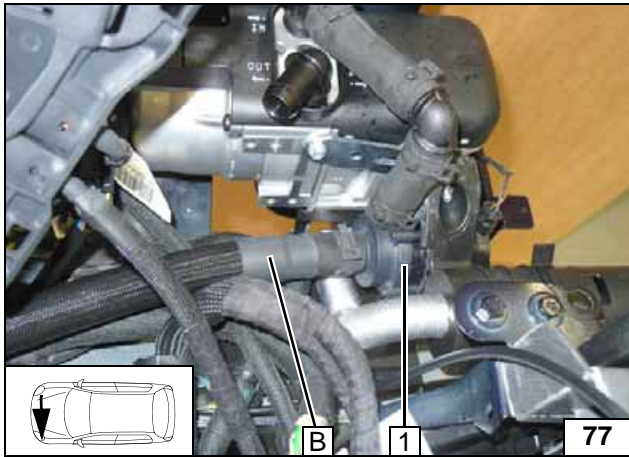

- 1 Circulating pump

**Connect-  
ing circu-  
lating  
pump**

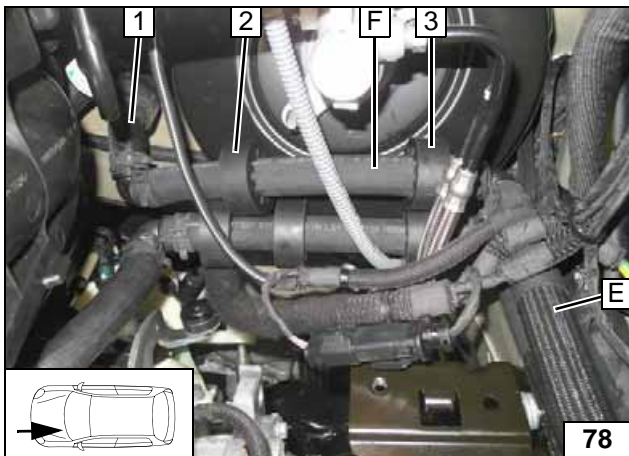

Align hoses. Ensure sufficient distance to neighbouring components; correct if necessary.

- 1 Hose of heat exchanger inlet
- 2 Align black (sw) rubber isolator with brake booster
- 3 Align black (sw) rubber isolator with brake line

**Connect-  
ing heat ex-  
changer  
inlet**



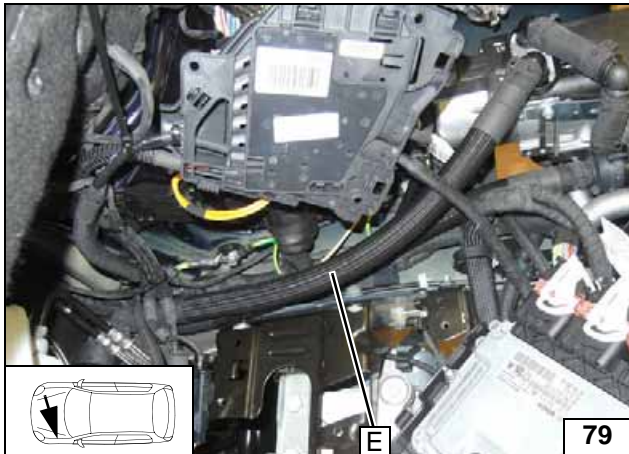

Routing in engine compartment

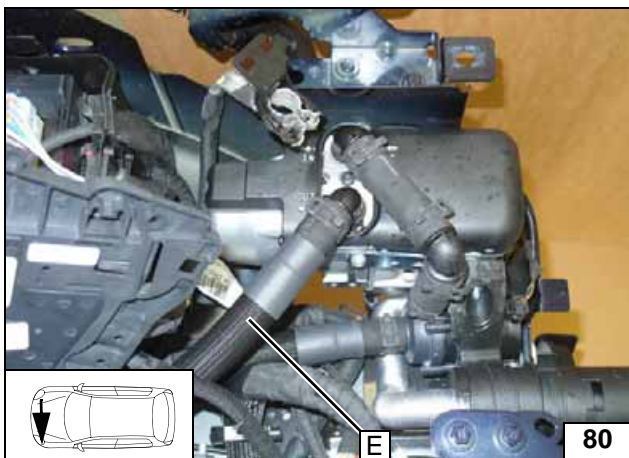

Connection of heater outlet

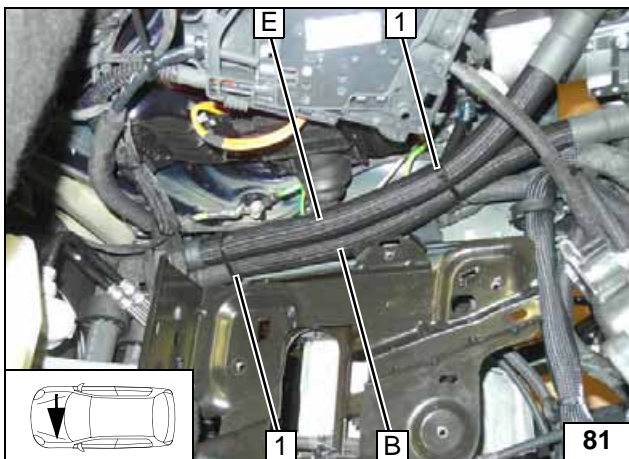

Ensure sufficient distance to neighbouring components; correct if necessary.



- 1 Cable tie around hoses and original vehicle wiring harness

Aligning hoses



## Final Work

### WARNING!

Mount removed parts in reverse order. Check all hoses, clamps and all electrical connections for firm seating. Insulate all loose wires and tie back.

Only use manufacturer-approved coolant. Spray the heater components with anti-corrosion wax (Tectyl 100K, Order No. 111329).



- **Connect the battery.**
- **Fill and bleed the coolant circuit according to the vehicle manufacturer's specifications.**
- **Adjust digital timer, teach telestart transmitter.**
- **Make settings on A/C control panel according to the "Operating Instructions for End Customer".**
- **Place the "Switch off parking heater before refuelling" caution label in the area of the filler neck.**
- **For initial startup and function check, please see installation instructions.**

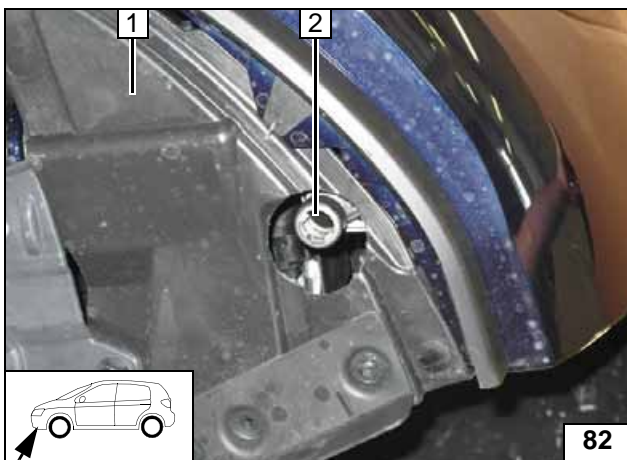

Align exhaust end section **2** with wheel well trim **1** flush and in the centre of the hole.

**Aligning  
exhaust  
end section**

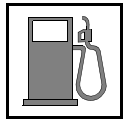

### Template for Petrol Fuel Standpipe

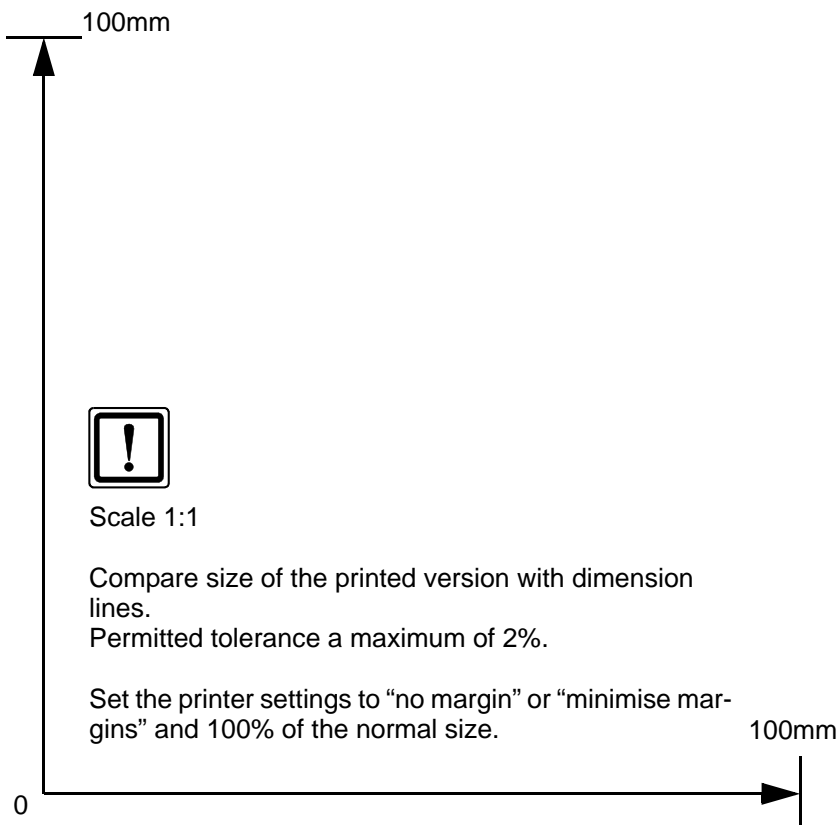
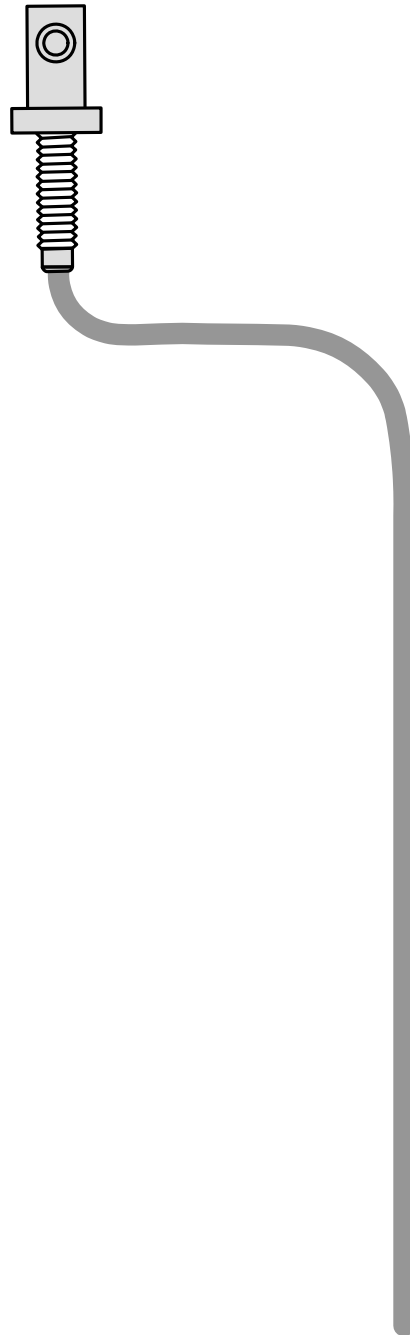



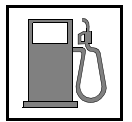

### Template for Diesel Fuel Standpipe

Top view

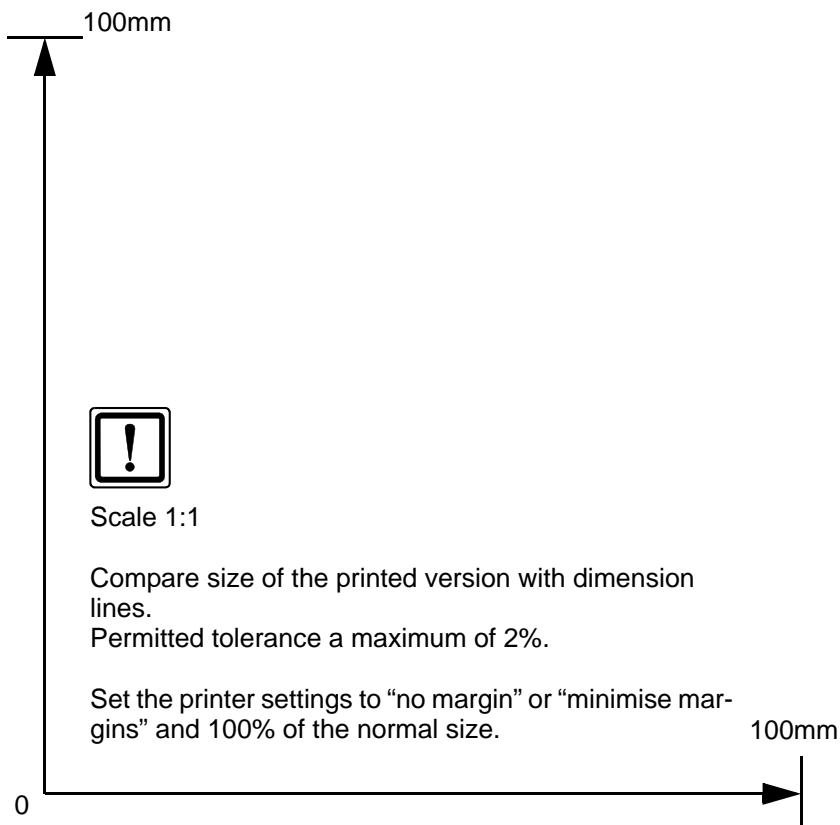
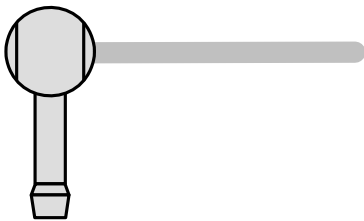



**Drilling Template for Heater Fastening**

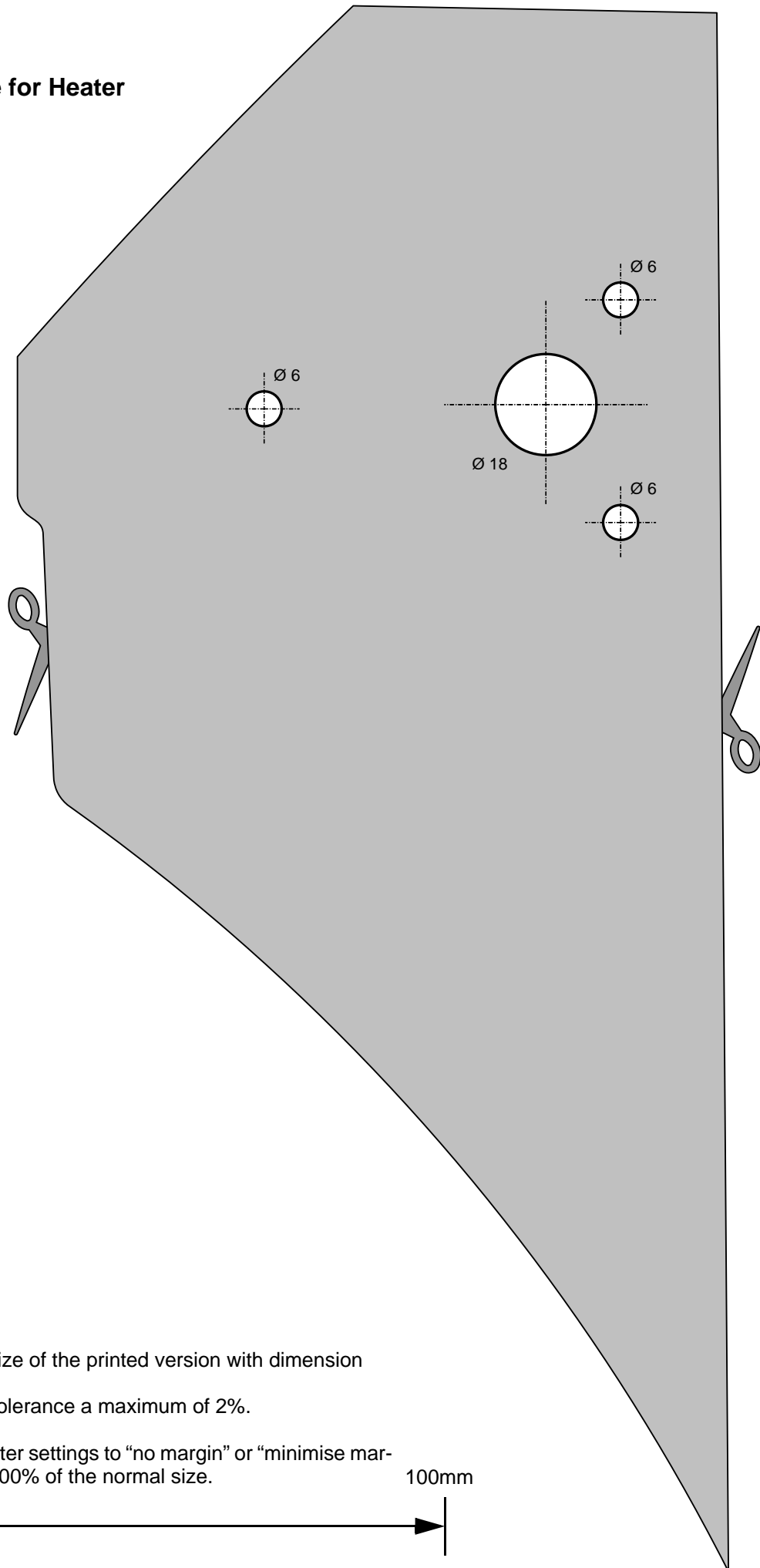

Scale 1:1

Compare size of the printed version with dimension lines.  
Permitted tolerance a maximum of 2%.

Set the printer settings to "no margin" or "minimise margins" and 100% of the normal size.

## Operating Instructions for End Customer

Please remove page and add to the vehicle operating instructions.

**Note:**

We recommend matching the heating time to the driving time.  
 Heating time = driving time

**Example:**

For a driving time of approx. 20 min. (in one direction), we recommend not exceeding a switch-on time of 20 min.

Passenger compartment monitoring, if installed, must be deactivated in addition to the vehicle settings for the heating operation.

For instructions on deactivation, please refer to the operating instructions of the vehicle.

Before parking the vehicle, make the following settings:



- 1 Air outlet onto windscreen
- 2 Set temperature to "max."



A/C control panel

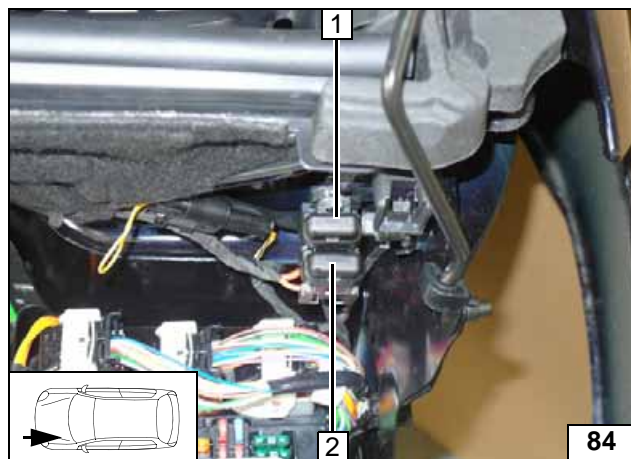

- 1 30A passenger compartment main fuse F2
- 2 20A heater fuse F1

Fuses of engine compartment

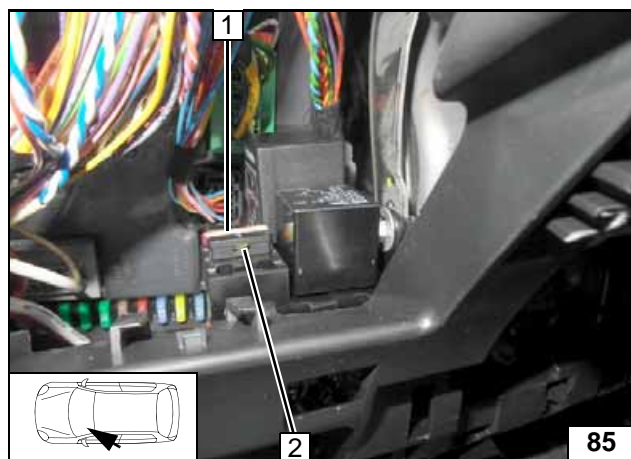

- 1 25A fan fuse F4
- 2 1A fuse of heater control F3

Fuses of passenger compartment

