

Water Heater

Thermo Top Evo Parking Heater



Installation Documentation

Citroen C4 Picasso

Validity

Manufacturer	Model	Type	EG-BE No. / ABE
Citroen	C4 Picasso	B78	e2 * 2007 / 46 * 0356 * ...

Motorisation	Fuel	Transmission type	Output in kW	Displacement in cm ³	Engine code
1.6 THP	Petrol	6-speed SG	115	1598	5FV8
1.6 VTi	Petrol	6-speed SG	88	1598	5FS0
1.6 HDi	Diesel	6-speed SG	85	1560	9HC8
1.6 HDi	Diesel	6-speed AG	68	1560	9HP8
2.0 HDi	Diesel	6-speed SG	110	1997	AH01

SG = Manual transmission

AG = Automatic transmission

From Model Year 2013

Left-hand drive vehicle

Verified equipment variants: Automatic air-conditioning
 Front fog lights
 Start-Stop

Not verified: Manual air-conditioning
 Passenger compartment monitoring
 Xenon
 Headlight washer system

Total installation time: approx. 10.5 hours

Citroen C4 Picasso

Table of Contents

Validity	1	Preparing Installation Location	15
Necessary Components	2	Preparing Heater	18
Installation Overview	2	Installing Heater	21
Information on Total Installation Time	2	Combustion Air	22
Information on Operating and Installation Instructions	3	Exhaust Gas	23
Information on Validity	4	Coolant Circuit Petrol	24
Technical Information	4	Coolant Circuit 1.6 Diesel	29
Explanatory Notes on Document	4	Cooland Circuit 2.0 Diesel	34
Preliminary Work	5	Fuel	38
Heater Installation Location	5	Final Work	44
Preparing Electrical System	6	Template for Petrol Fuel Standpipe	46
Electrical System	8	Template for Diesel Fuel Standpipe	47
Fan Controller	9	Operating Instructions for End Customer	48
Glove Compartment Removal Instructions	10		
Digital Timer	13		
Remote Option (Telestart)	13		
Remote Option (Thermo Call)	14		

Necessary Components

- Basic delivery scope of *Thermo Top Evo* based on price list
- Installation kit for Citroen C4 Picasso 2013 Petrol and Diesel: **1321284C**
- Heater control in accordance with price list and upon consultation with end customer
- In case of Telestart, indicator lamp in accordance with price list and in consultation with end customer

Installation instructions:

- Arrange for the vehicle to be delivered with the tank only about ¼ full!
- The installation location of the push button in case of Telestart or Thermo Call should be confirmed with the end customer.
- Depending on the available space and manufacturer's instructions, we recommend the use of a vehicle battery with more electrical capacity.

Installation Overview

Legend:

1. Heater
2. Fuse holder of engine compartment
3. Passenger compartment relay and fuse holder
4. PWM Gateway and K2 relay
5. Circulating pump
6. Digital Timer
7. Metering pump

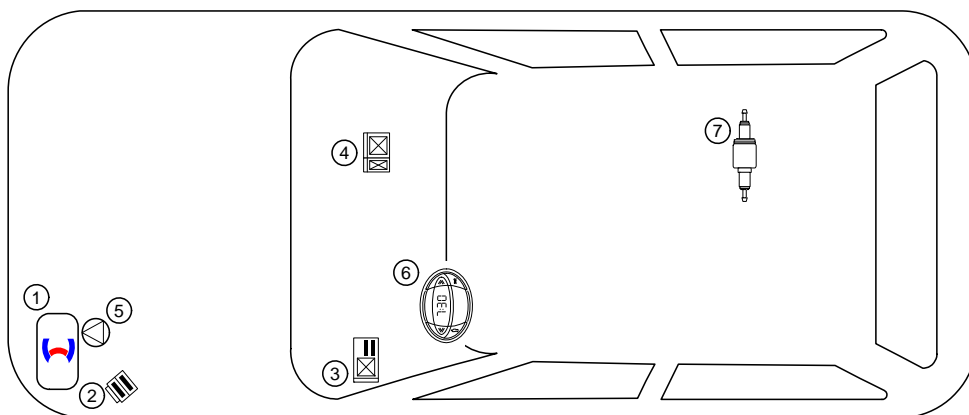

Information on Total Installation Time

The total installation time includes the time needed for mounting and demounting of the vehicle-specific components, the heater specific installation time and all other times required for the system integration and initial start-up of the heater.

The total installation time may vary for vehicle equipment other than provided.

Information on Operating and Installation Instructions

1 Important notes (not complete)

1.1 Installation and Repair



The improper installation or repairing of Webasto heating and cooling systems can cause fire or the leakage of deadly carbon monoxide, leading to serious injury or death.



To install and repair Webasto heating and cooling systems you need to have completed a special company training course and have the appropriate technical documentation, special tools and special equipment.



Installation and repair may ONLY be carried out by persons trained and certified in a Webasto training course. NEVER try to install or repair Webasto heating or cooling systems if you have not completed a Webasto training course, you do not have the necessary technical skills and you do not have the technical documentation, tools and equipment available to ensure that you can complete the installation and repair work properly.

Only use genuine Webasto parts. See the Webasto air and water heaters accessories catalogue for this purpose.

1.2 Operation

To ensure safe operation, we recommend having the heater checked every two years by an authorised Webasto dealer, especially when used over a long period and/or under extreme environmental conditions.

Do not operate the heater in closed rooms due to the danger of poisoning and suffocation.

Always switch off the heater before refuelling.

The heater may only be used with the prescribed fuel Diesel (DIN EN 590) or petrol (DIN EN 227).

The heater may not be cleaned with a high-pressure cleaner.

1.3 Please note

ALWAYS follow all Webasto installation and operating instructions and observe all warnings.

To become familiar with and understand all functions and properties of the heater, the operating instructions must be read carefully and observed at all times.

For proper, safe installation and repair work, the installation instructions with all warnings and safety information must be carefully read and observed at all times. Please always contact a workshop authorised by Webasto for all installation and repair work.

Important

Webasto shall assume no liability for defects, damage and injuries resulting from a failure to observe the installation, repair and operating instructions of the information contained in them.

This liability exclusion particularly applies to improper installations and repairs, installations and repairs by untrained persons or in the case of a failure to use genuine spare parts.

The liability due to culpable disregard to life, limb or health and due to damage or injuries caused by a wilful or reckless breach of duty remain unaffected, as does the obligatory product liability.

Installation should be carried out according to the general, standard rules of technology. Unless specified otherwise, fasten hoses, lines and wiring harnesses to original vehicle lines and wiring harnesses using cable ties. Insulate loose wire ends and tie back. Connectors on electronic components have to audibly click into place during installation.

Sharp edges should be fitted with rub protection. Spray unfinished body areas, e.g. drilled holes, with anti-corrosion wax (Tectyl 100K, Order No. 111329).

Observe the instructions and guidelines of the respective vehicle manufacturer for demounting and mounting vehicle specific components!

The initial startup is to be executed with the Webasto Thermo Test Diagnosis.

When installing a PWM-Gateway, the corresponding settings must be checked or adjusted before the installation.

2 Statutory regulations governing installation

Guidelines	Thermo Top Evo
Heating Directive ECE R122	E1 00 0258
EMC Directive ECE R10	E1 04 5627

Note

The regulations of these guidelines are binding in the scope of the Directive 70/156/EEC and/or 2007/46/EC (for new vehicle models from 29/04/2009) and should also be observed in countries in which there are no special regulations.

Important

Failure to follow the installation instructions will result in the invalidation of the type approval for the heater and therefore invalidation of the general **homologation of the vehicle**.

Note

For vehicles with an EU permit, no entry in accordance with § 19 Sub-Section 4 of Annex VIII b to the Road Traffic Act is required.

2.1 Excerpt from the directive 2001/56/EC Appendix VII for the installation of the heater

Beginning of excerpt.

ANNEX VII

REQUIREMENTS FOR COMBUSTION HEATERS AND THEIR INSTALLATION

1. GENERAL REQUIREMENTS

1.7.1. A clearly visible operation indicator in the operator's field of view shall inform when the combustion heater is switched on or off.

2. VEHICLE INSTALLATION REQUIREMENTS

2.1. Scope

2.1.1. Subject to paragraph 2.1.2. combustion heaters shall be installed according to the requirements of this Annex.

2.1.2. Vehicles of category O having liquid fuel heaters are deemed to comply with the requirements of this Annex.

2.2. Positioning of heater

2.2.1. Body sections and any other components in the vicinity of the heater must be protected from excessive heat and the possibility of fuel or oil contamination.

2.2.2. The combustion heater shall not constitute a risk of fire, even in the case of overheating. This requirement shall be deemed to be fulfilled if the installation ensures an adequate distance to all parts and suitable ventilation, by the use of fire resistant materials or by the use of heat shields.

2.2.3. In the case of M2 and M3 vehicles, the heater must not be positioned in the passenger compartment. However, an installation in an effectively sealed envelope which also complies with the conditions in paragraph 2.2.2 may be used.

2.2.4. The label referred to in paragraph 1.4 or a duplicate, must be positioned so that it can be easily read when the heater is installed in the vehicle.

2.2.5. Every reasonable precaution should be taken in positioning the heater to minimise the risk of injury and damage to personal property.

2.3. Fuel supply

2.3.1. The fuel filler must not be situated in the passenger compartment and must be provided with an effective cap to prevent fuel spillage

2.3.2. In the case of liquid fuel heaters, where a supply separate to that of the vehicle is provided, the type of fuel and its filler neck must be clearly labelled

2.3.3. A notice, indicating that the heater must be shut down before refuelling, must be affixed to the filler neck. In addition a suitable instruction must be included in the manufacturer's operating manual.

2.4. Exhaust system

2.4.1. The exhaust gas outlet must be located so as to prevent emissions from entering the vehicle through ventilators, heated air inlets or opening windows.

2.5. Combustion air inlet

2.5.1. The air for the combustion chamber of the heater must not be drawn from the passenger compartment of the vehicle.

2.5.2. The air inlet must be so positioned or guarded that blocking by rubbish or luggage is unlikely.

2.6. Heating air inlet

2.6.1. The heating air supply may be fresh or recirculated air and must be drawn from a clean area not likely to be contaminated by exhaust fumes emitted either by the propulsion engine, the combustion heater or any other vehicle source.

2.6.2. The inlet duct must be protected by mesh or other suitable means.

2.7. Heating air outlet

2.7.1. Any ducting used to route the hot air through the vehicle must be so positioned or protected that no injury or damage could be caused if it were to be touched.

2.7.2. The air outlet must be so positioned or guarded that blocking by rubbish or luggage is unlikely.

End of excerpt.

In multilingual versions the German language is binding.

Citroen C4 Picasso

Information on Validity

This installation documentation applies to Citroen C4 Picasso Petrol and Diesel vehicles - for validity, see page 1 - from model year 2013 and later, assuming technical modifications to the vehicle do not affect installation, any liability claims excluded. Depending on the vehicle version and equipment, modifications may be necessary during installation with respect to these "installation instructions".

Vehicle and engine types, equipment variants and other specifications not listed in this installation documentation have not been tested. However, installation according to this installation documentation may be possible.

Technical Information

Special Tools

- Hose clamp pliers for auto-tightening hose clamps
- Hose clamp pliers for Clic hose clamps of type W
- Automatic wire stripper 0.2 - 6mm²
- Crimping pliers for cable lug / tab connector 0.5 - 6mm²
- Torque wrench for 2.0 - 10 Nm
- Hose clamping pliers
- Metric thread-setter kit
- Webasto Thermo Test Diagnosis with current software

Dimensions

- All dimensions in mm.

Tightening torque values

- Tightening torque values for 5x13 heater bolts and 5x11 heater stud bolts = 8Nm.
- Tightening torque values of 5x15 retaining plate of water connection piece bolts = 7Nm.
- Tighten other bolt connections in accordance with manufacturer's instructions or in accordance with state-of-the-art-technology.

Explanatory Notes on Document

You will find an identification mark on the outside top right corner of the page in question to provide you with a quick overview of the individual working steps.

Special features are highlighted using the following symbols:

Mechanical system



Electrical System



Coolant Circuit



Combustion Air



Fuel



Exhaust gas



Software



Special risk of injury or fatal accidents.



Specific risk of damage to components.



Specific risk of fire or explosion.



Reference to general installation instructions of the Webasto component or to vehicle specific documents of the manufacturer



Reference to a special technical feature.



The arrow in the vehicle icon indicates the position on the vehicle and the viewing angle.

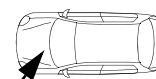
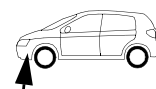

Citroen C4 Picasso

Preliminary Work

Vehicle

- Open the fuel tank cap.
- Ventilate the fuel tank.
- Close the fuel tank cap again.
- Depressurise the cooling system.
- Remove the windscreen wiper.
- Remove the coolant reservoir cap.
- Remove the cowl cover on the engine side.
- Disconnect and completely remove the battery with carrier.
- Remove the air filter box completely.
- Remove the left front wheel.
- Remove the left-hand wheel well trim.
- Remove the lower engine cover (if present).
- Remove the right rear underride protection.
- Remove the horn.
- Remove the A-pillar trim on the driver's side (only with Telestart).
- Remove the lower instrument panel trim on the driver's and front passenger's side.
- Remove the instrument panel trim on the right side (see installation instructions).
- Remove the lateral instrument panel trim of the centre console on the front passenger's side (see installation instructions).
- Remove the glove compartment (see installation instructions).
- Remove the middle rear seat.
- Remove the fuel-tank sending unit in accordance with the manufacturer's instructions.

Heater

- Remove years that do not apply from the type and duplicate label.
- Attach the duplicate label (type label) in the appropriate place in the engine compartment.

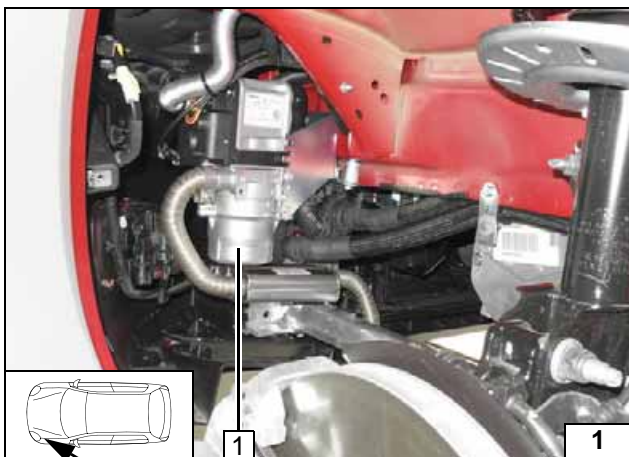

Heater Installation Location

1 Heater

Installation location

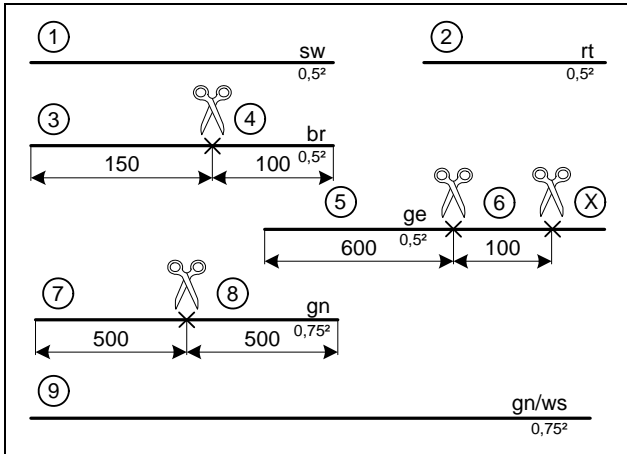
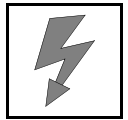

Preparing Electrical System

Wire sections retain their numbering throughout the entire document.

Discard section X.



Cutting wires to length

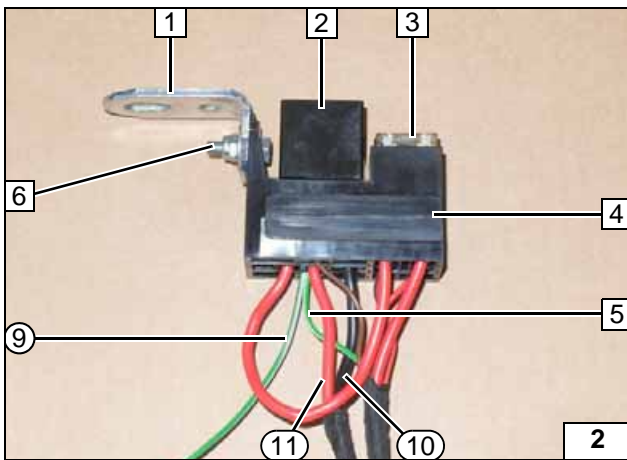

Detach and remove contact of K1/86. Install wires as shown in following wiring diagram with contacts supplied. Insert 25A fuse F4 3 and K1 relay 2 after installation.

- 1 Angle bracket
- 4 Relay and fuse holder of passenger compartment
- 5 Green/white (gn/ws) wire of K1/86
- 6 M5x16 bolt, large diameter washer [2x], retaining plate of fuse holder, nut



Preparing passenger compartment relay and fuse holder

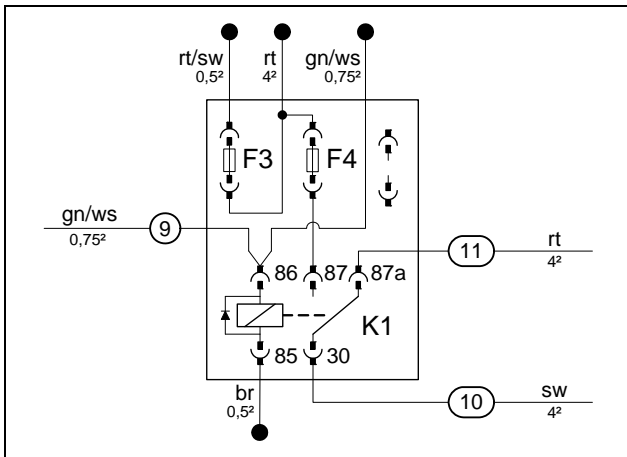

Pull green/white (gn/ws) wire of 9 K1/86 into protective sleeving.

- 10 Black (sw) wire of fan wiring harness
- 11 Red (rt) wire of fan wiring harness



Preparing passenger compartment relay and fuse holder

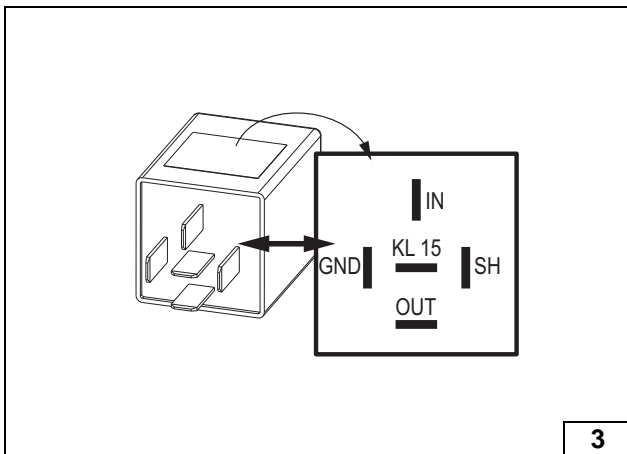

Check the PWM Gateway settings when starting up the heater and adjust if necessary.

Settings:

- Duty cycle: 70%
- Frequency: 400Hz
- Function: Low-side



Preparing PWM Gateway

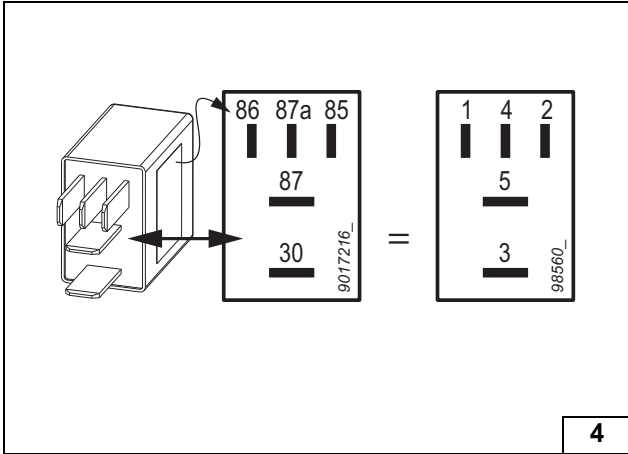
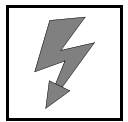

Preparing K2-relay

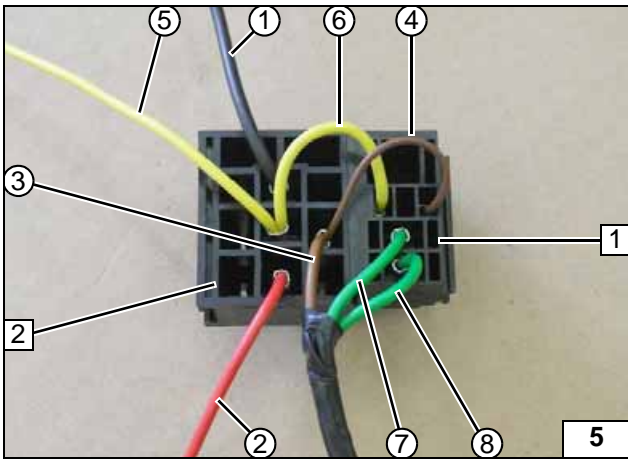

Connect wires according to the following wiring diagram. Interlock socket of K2 relay 1 and socket of PWM Gateway 2.



Preparing K2 relay and PWM Gateway

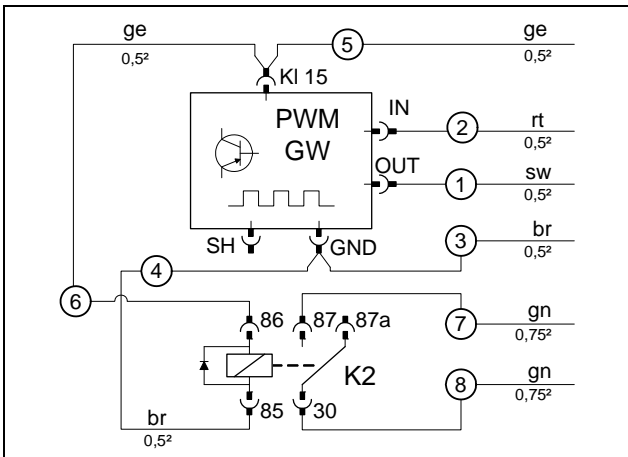

Connect lines.



Preparing K2 relay and PWM Gateway

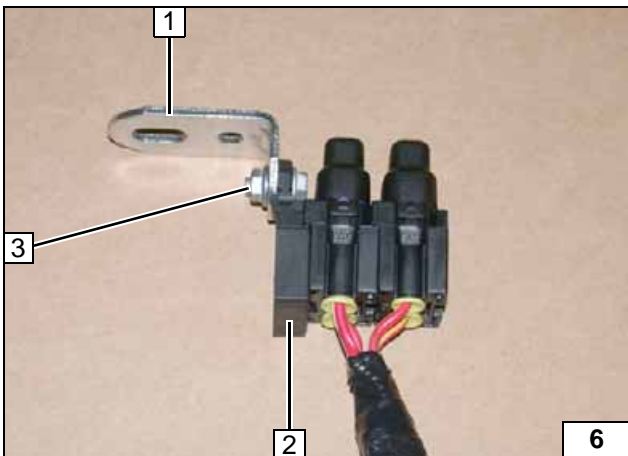

- 1 Angle bracket
- 2 Retaining plate of fuse holder
- 3 M5x16 bolt, large diameter washer [2x], nut

Preparing fuse holder of engine compartment



Electrical System



Positive wire

- 1 Positive wire on positive battery distributor

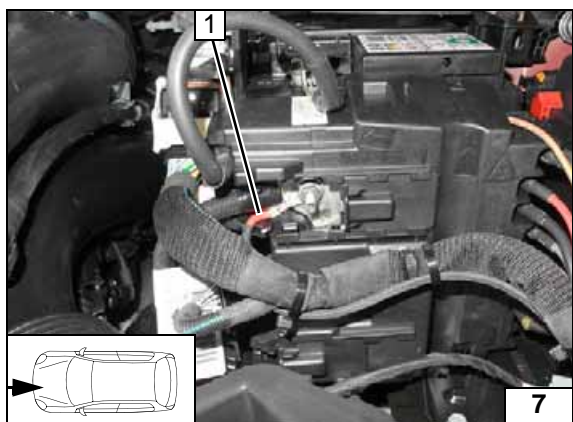

Wiring harness pass through

- 1 Protective rubber plug

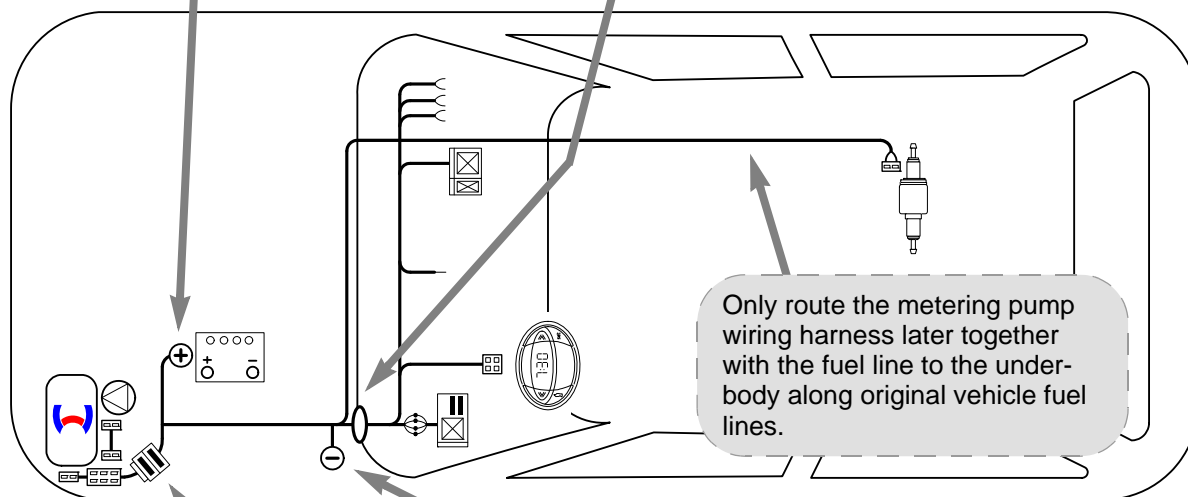
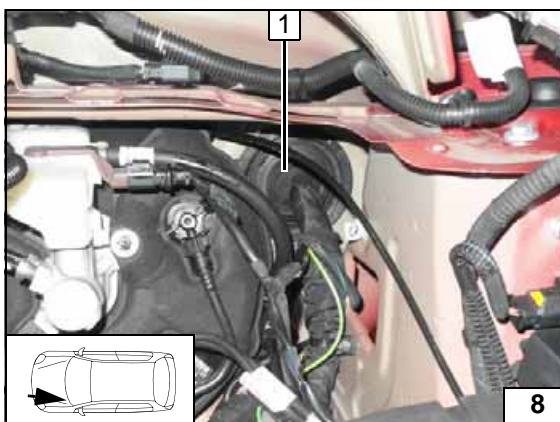

Wiring harness routing diagram

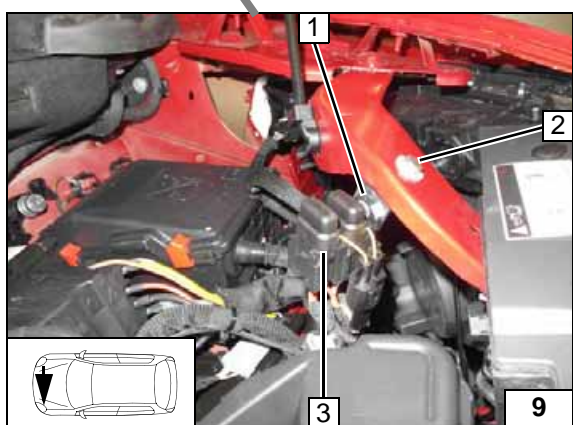

Fuse holder of engine compartment

- 1 Angle bracket
- 2 M6x20 bolt, large diameter washer [2x], flanged nut
- 3 F1-2 fuses



Earth wire

- 1 Earth wire on original vehicle earth support point

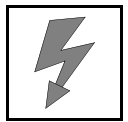

Fan Controller



Wiring diagram

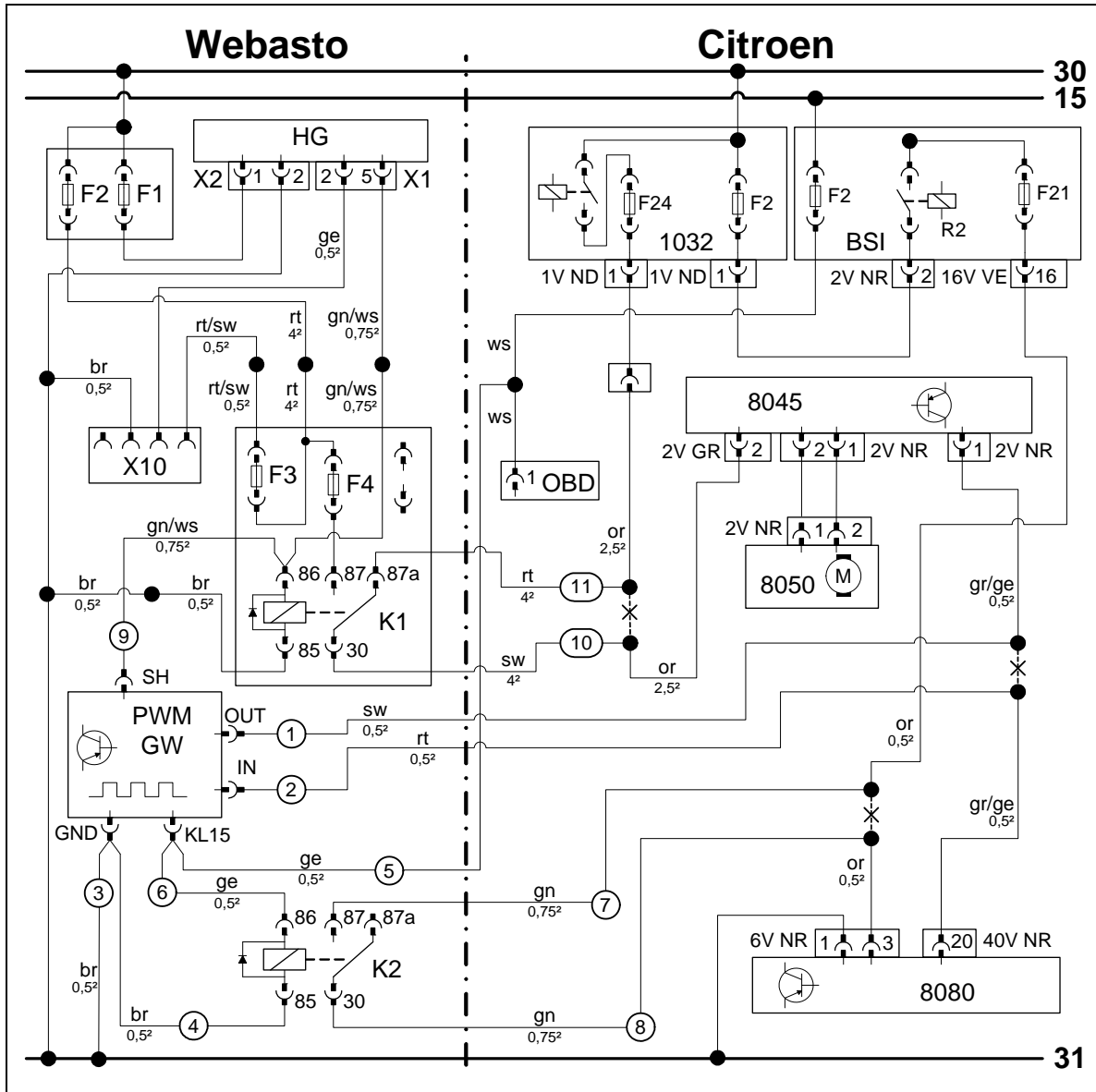

Webasto components		Vehicle components		Colours and symbols	
HG	TT-Evo heater	BSI	Central electrical box for passenger compartment	rt	red
X1	6-pin heater connector	F2	Fuse 5A (BSI)	sw	black
X2	2-pin heater connector	2V NR	2-pin connector BSI	ge	yellow
X10	4-pin connector of heater control	16V VE	16-pin connector BSI	gn	green
K1	Fan relay	1032	Main power supply	or	orange
F1	20A fuse	1V ND	1-pin connector 1032	ws	white
F2	30A fuse	8045	Fan controller	br	brown
F3	1A fuse	2V GR	2-pin connector 8045	gr	grey
F4	25A fuse	2V NR	2-pin connector 8045		
K2	Additional relay	OBD	Socket outlet of OBD		
PWM GW	PWM Gateway	2V NR	2-pin connector 8050		
		8050	Fan motor		
		6V NR	6-pin connector 8080		
		40V NR	40-pin connector 8080		
Settings of PWM Gateway:		8080	A/C control unit		
Duty cycle: 70%					
Frequency: 400Hz				X	Cutting point
Function: Low-side					Wiring colours may vary.

Legend

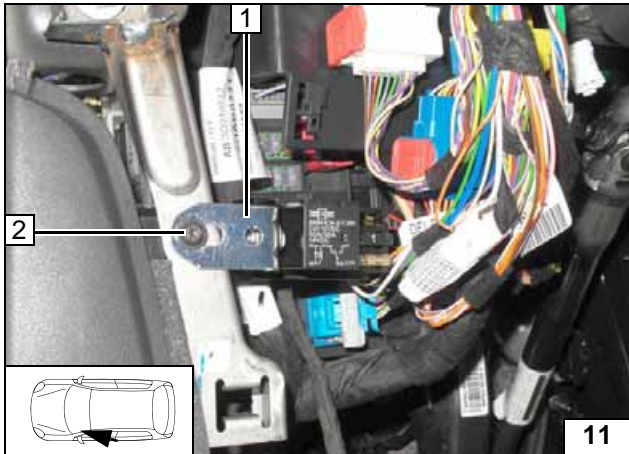

Route green/white (gn/ws) wire ⑨ of K1/86 to centre console on front passenger's side.



- 1 Angle bracket
- 2 Original vehicle bolt

Mounting passenger compartment relay and fuse holder

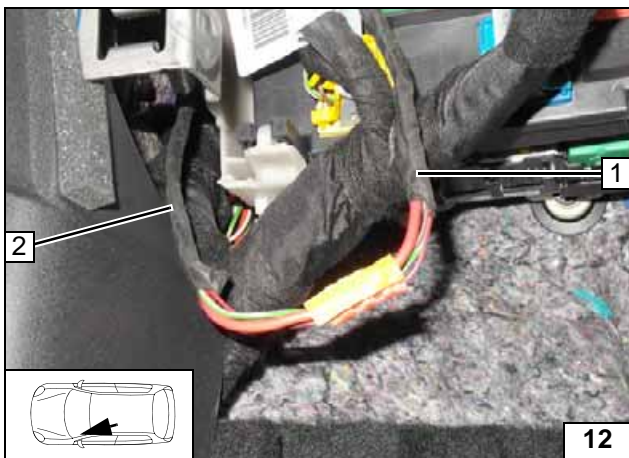

- 1 Wiring harness of passenger compartment relay and fuse holder
- 2 Wiring harness of heater

Connecting wiring harnesses using same colour wires



Glove Compartment Removal Instructions

Fastening points (○)



- 1 Lateral trim

Removing trim

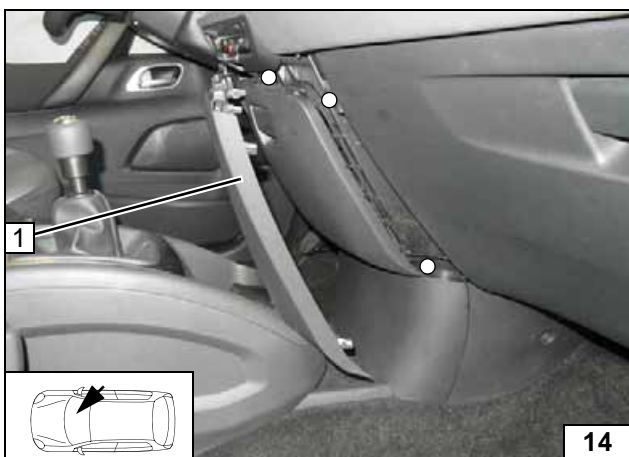

Fastening points (○)



- 1 Lateral trim compartment centre console

Detaching trim

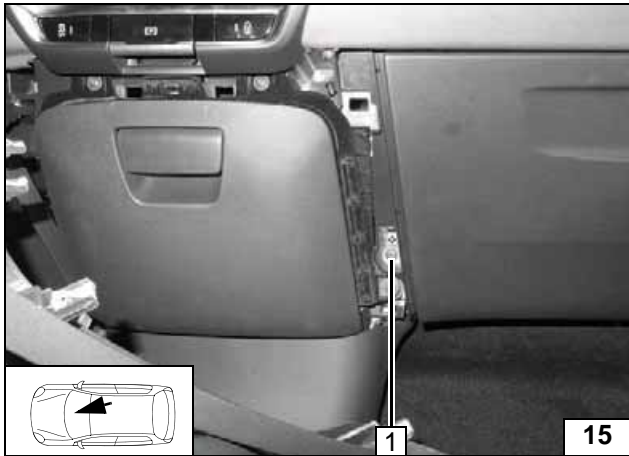

1 Original vehicle bolt

Removing bolt

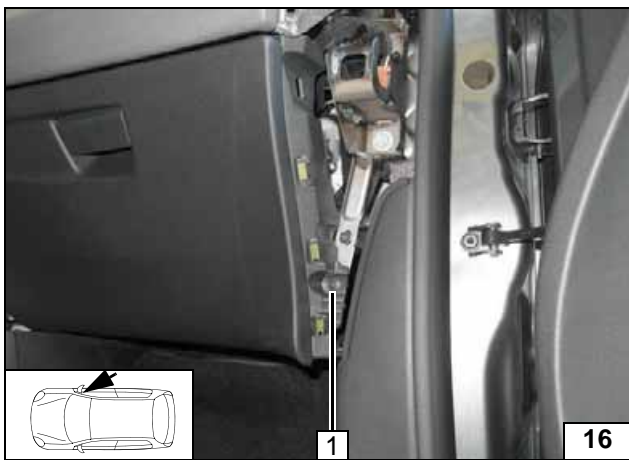

1 Original vehicle bolt

Removing bolt

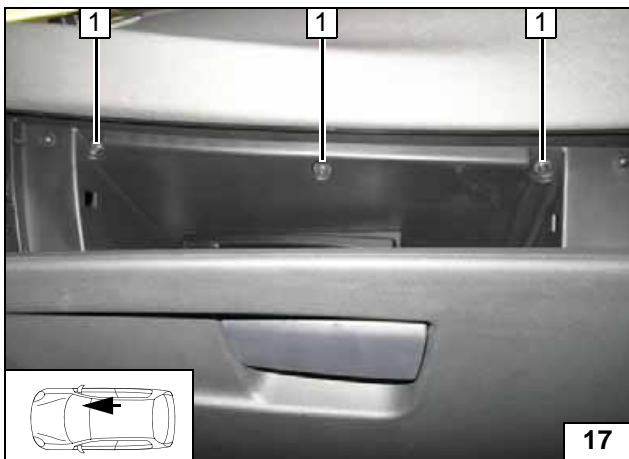

1 Original vehicle bolt [3x]

Removing bolts

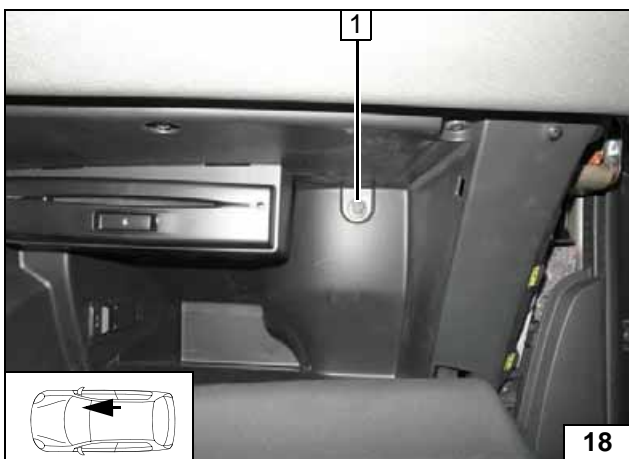

1 Original vehicle bolt

Removing bolt

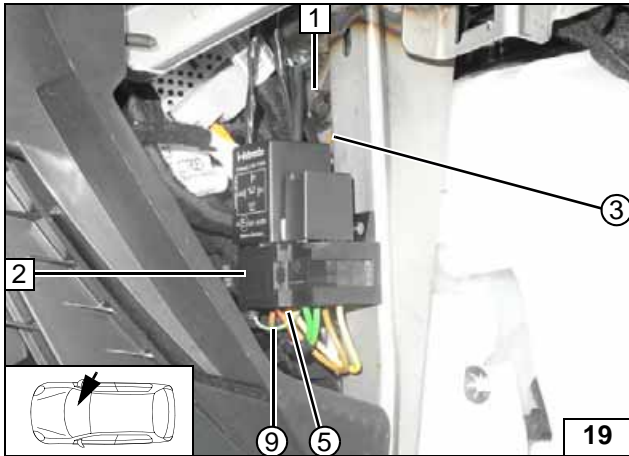
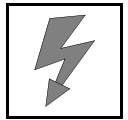

Fan controller

Connect green/white (gn/ws) wire of ⑨ K1/86 to socket of PWM Gateway/SH. Route yellow (ge) wire of ⑤ PWM Gateway/KL 15 to centre console on driver's side.

- 1 Original vehicle earth support point
- 2 Secure socket of PWM Gateway with adhesive tape.
- ③ Brown (br) wire of PWM Gateway/GND



Installing K2 relay and PWM Gateway

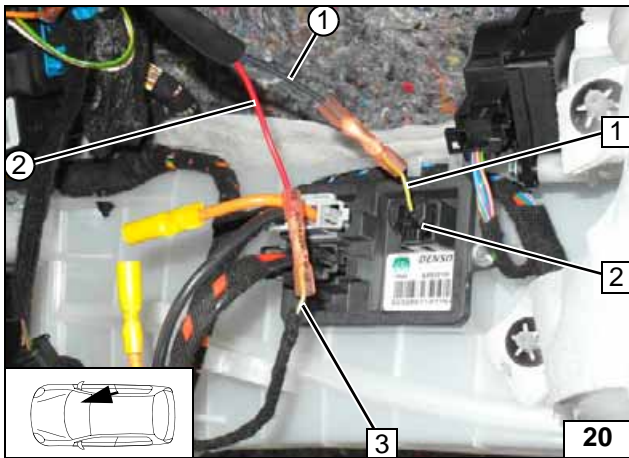

Connection to 2-pin connector 2V NR 2 from fan controller. Produce connections as shown in wiring diagram.

- 1 Grey/yellow (gr/ge) wire of fan controller 2V NR/1
- 3 Grey/yellow (gr/ge) wire of A/C control unit 40V NR/20
- ① Black (sw) wire of PWM Gateway/OUT
- ② Red (rt) wire of PWM Gateway/IN



Connection of PWM Gateway

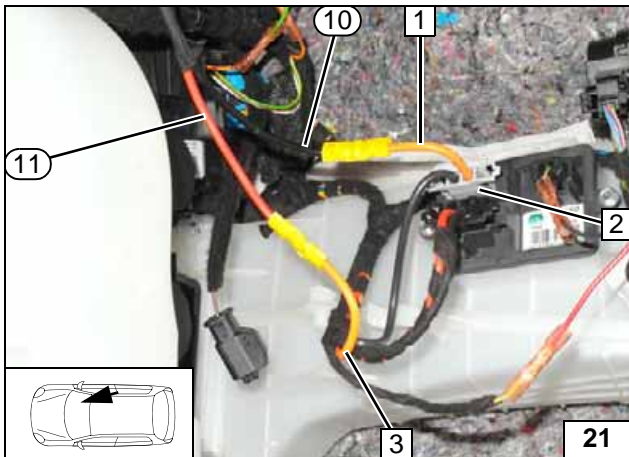

Connection to 2-pin connector 2V GR 2 of fan controller. Produce connections as shown in wiring diagram.

- 1 Orange (or) wire of fan controller 2V GR/2
- 3 Orange (or) wire of power supply F24
- ⑩ Black (sw) wire from K1/30
- ⑪ Red (rt) wire of K1/87a



Connection of K1 relay

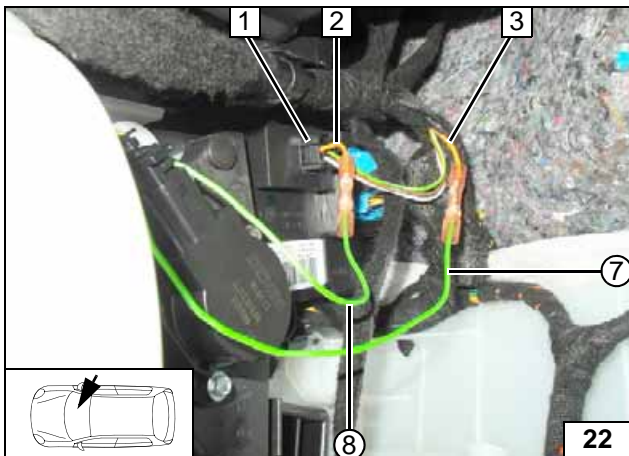

Connection to 6-pin connector 6V NR 1 A/C control unit. Produce connections as shown in wiring diagram.

- 2 Orange (or) wire of A/C control unit 6V NR/3
- 3 Orange (or) wire of BSI 16V VE/16
- ⑦ Green (gn) wire from K2/87
- ⑧ Green (gn) wire from K2/30



Connection of K2 relay

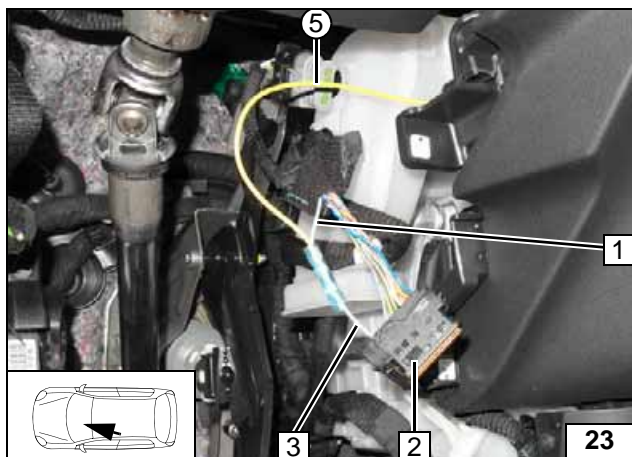
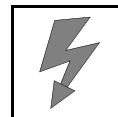

Connection to OBD socket outlet **2**.
Produce connections as shown in wiring diagram.



- 1 White (ws) wire of Terminal 15
- 3 White (ws) wire of OBD socket outlet, Pin 1
- 5 Yellow (ge) wire of PWM Gateway/KL 15

**Connec-
tion of ter-
minal 15**



Digital Timer

- 1 Digital timer



**Installing
digital timer**

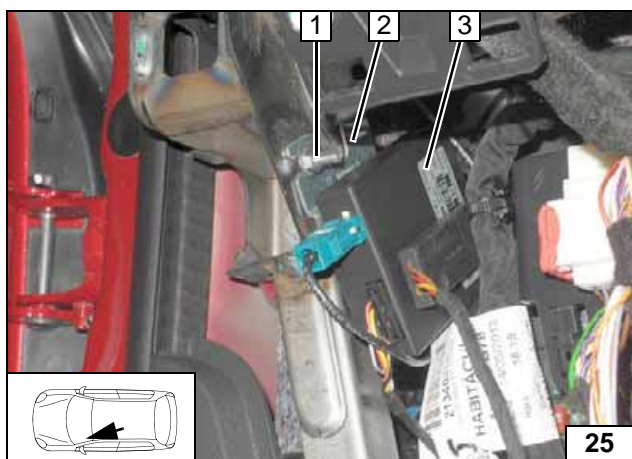

Remote Option (Telestart)

Place bracket **2** with receiver **3** from the inside on vehicle body and copy hole pattern at position **1**.



- 1 Hole 5.5mm dia.; M5x16 bolt, flanged nut

**Installing
receiver**

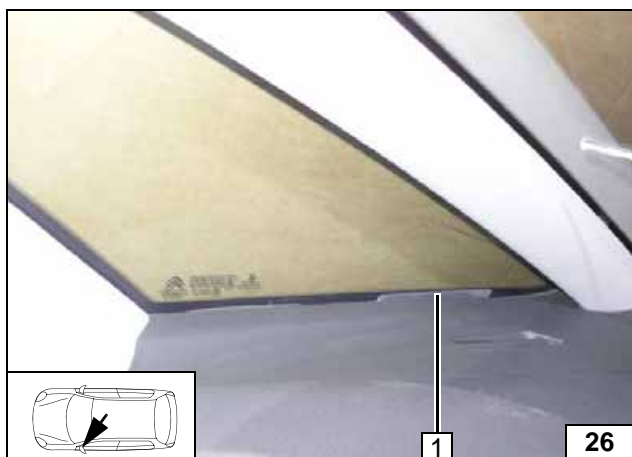

- 1 Antenna

**Installing
antenna**

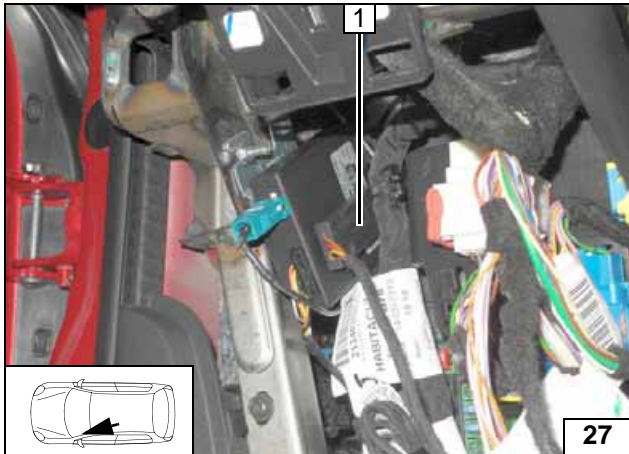

Temperature sensor T100 HTM

Fasten temperature sensor 1 with adhesive tape.



Installing temperature sensor

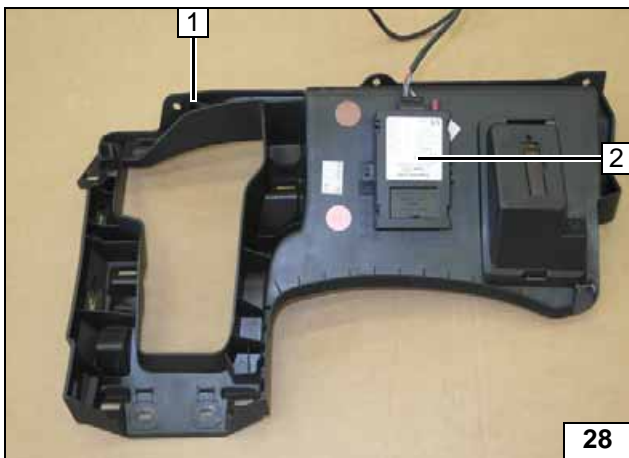

Remote Option (Thermo Call)

Fasten receiver with adhesive tape.

- 1 Instrument panel trim on driver's side



Installing receiver

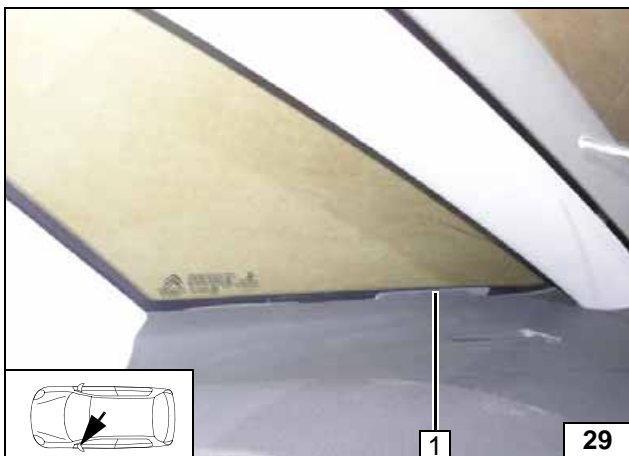

- 1 Antenna

Installing antenna

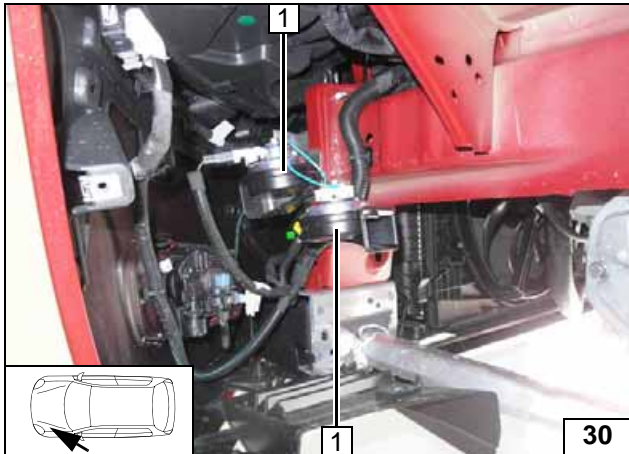

Preparing Installation Location

- 1 Horns [2x] 1 with bracket

Removing horns

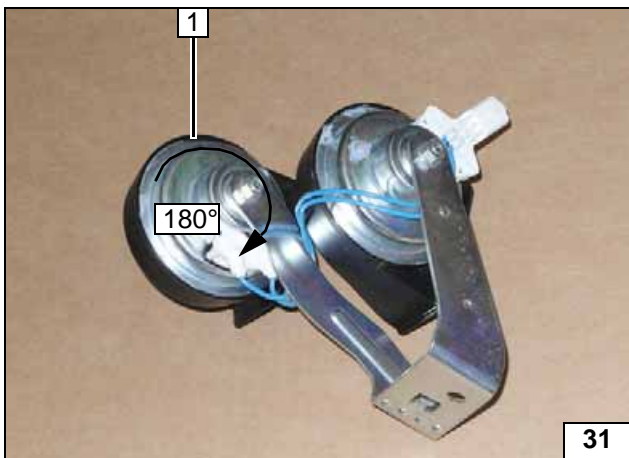

- 1 Rotate horn by 180°

Rotating horn

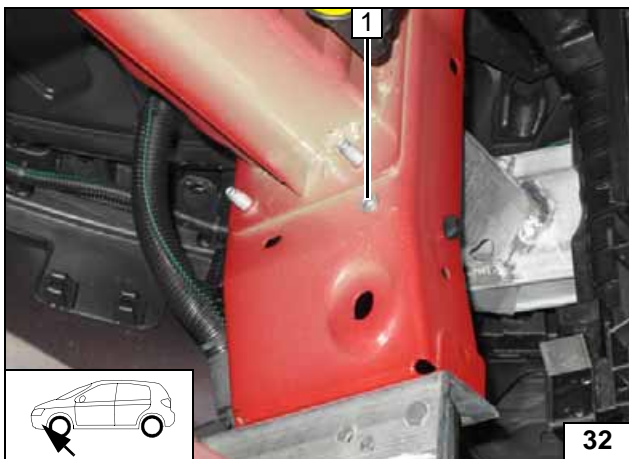

- 1 Drill out hole to 9.1mm dia.; rivet nut for horn bracket

Installing rivet nut

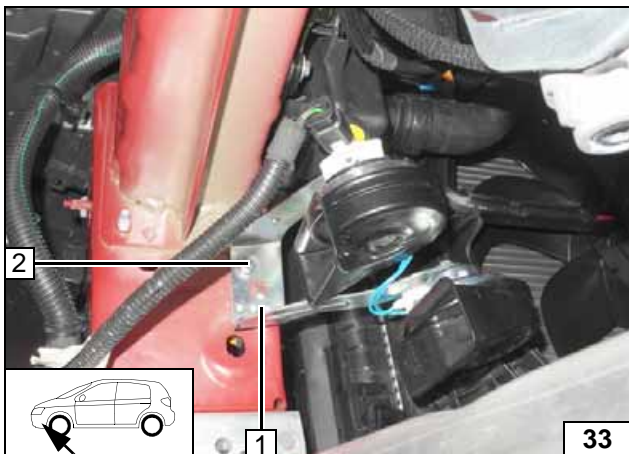

- 1 Horn bracket
- 2 M6x20 bolt, spring lockwasher, large diameter washer

Installing horn

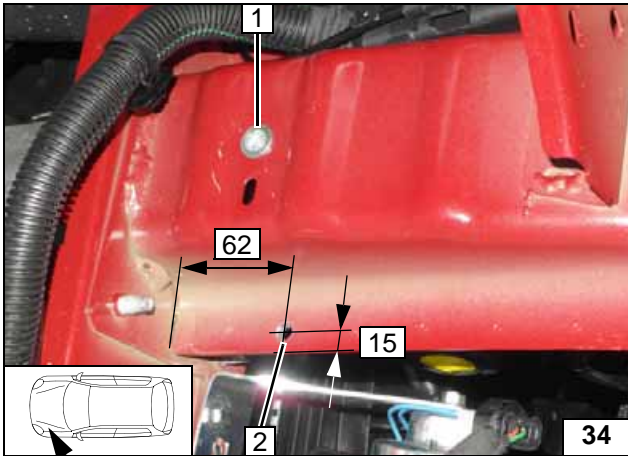
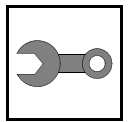

- 1 Drill out hole to 12.5mm dia.; M8 rivet nut
- 2 7mm dia. hole for circulating pump

Inserting M8 rivet nut

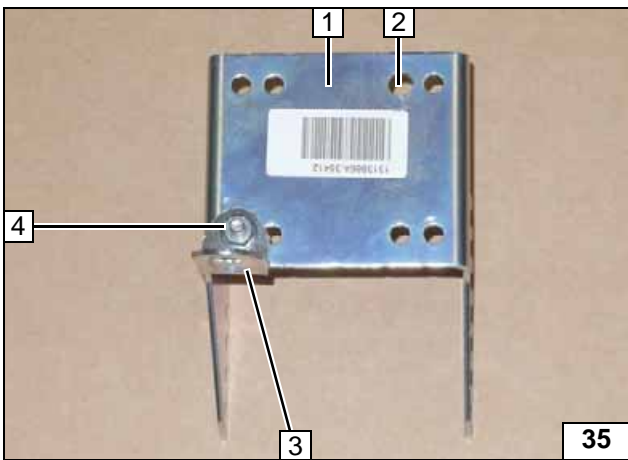

- 1 Bracket
- 2 Drill out hole to 8.5 mm dia.
- 3 Angle bracket
- 4 M6x16 bolt, flanged nut

Preparing bracket

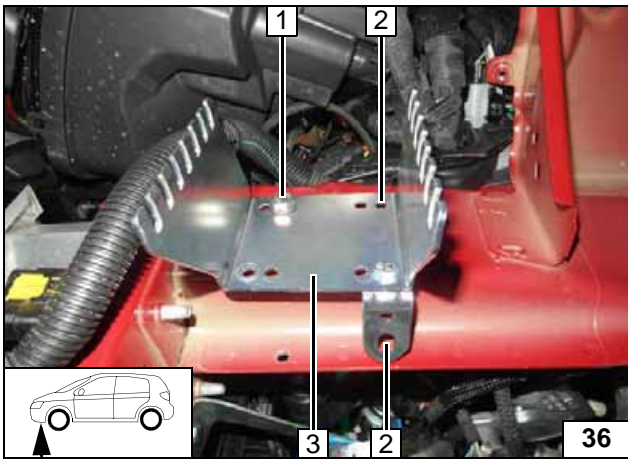

Install bracket 3 loosely and align perpendicularly. Insert 5mm shim between bracket 3 and frame side member.



- 1 M8x25 bolt, spring lockwasher, 5mm shim
- 2 Copy hole pattern [2x]

Copying hole pattern

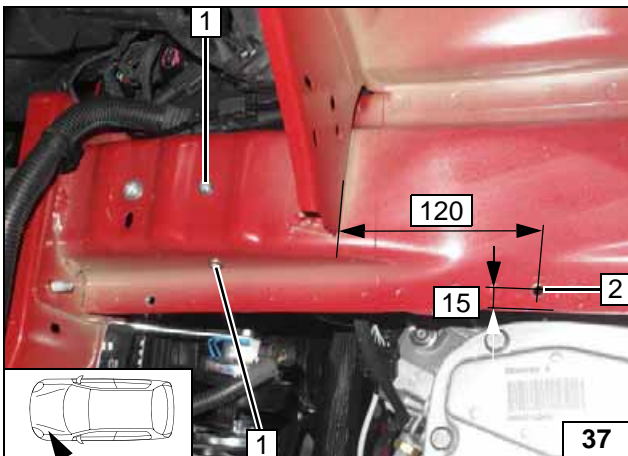

7 mm dia. hole at position 2 is only used for the hose fastening for 1.6 Petrol and 1.6 Diesel vehicles.



- 1 9.1mm dia. hole; M6 rivet nut [2x each]

Inserting M6 rivet nut

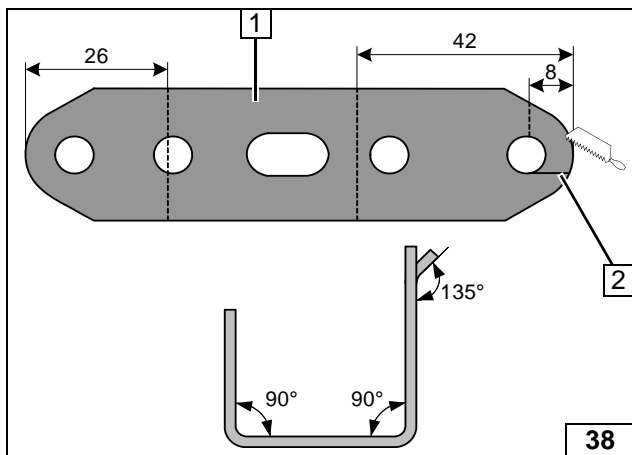

All vehicles

Saw perforated bracket 1 at position 2 and bend by 45°.

Preparing perforated bracket

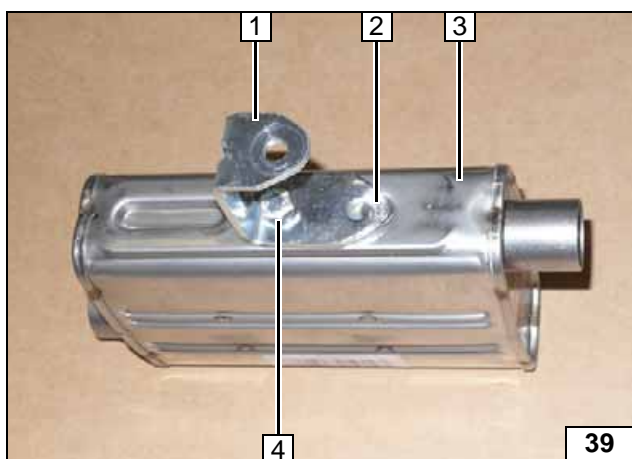

- 1 Perforated bracket
- 2 Twist protection (bent by 45°)
- 3 Exhaust silencer
- 4 M6x16 bolt, spring lockwasher

Premounting exhaust silencer

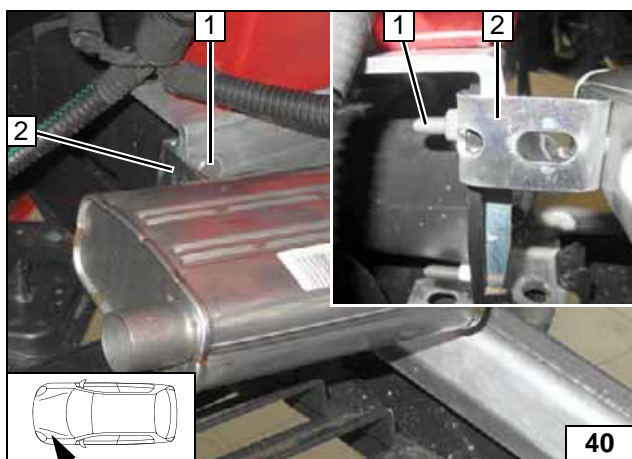

- 1 Original vehicle stud bolt, original vehicle nut
- 2 Perforated bracket

Installing exhaust silencer

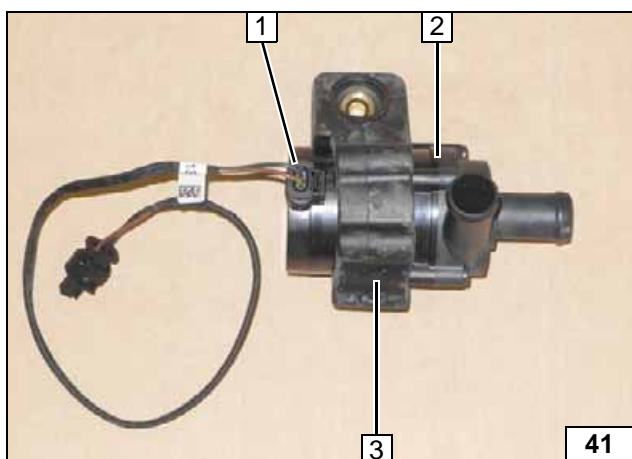

- 1 Wiring harness of circulating pump
- 2 Circulating pump
- 3 Circulating pump mounting

Premounting circulating pump

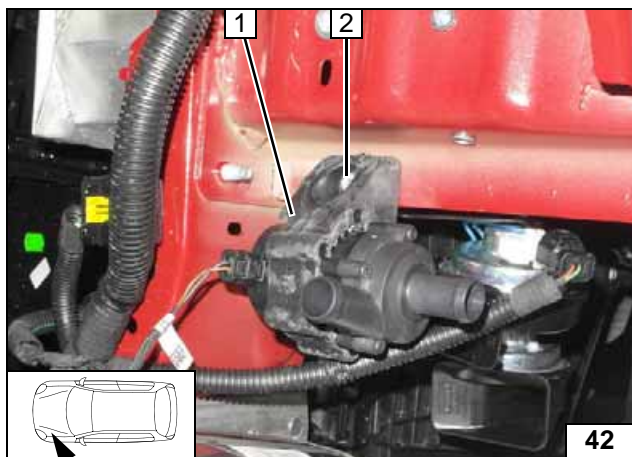
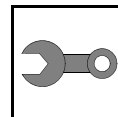

- 1 Circulating pump mounting
- 2 M6x25 bolt, flanged nut

Mounting circulating pump

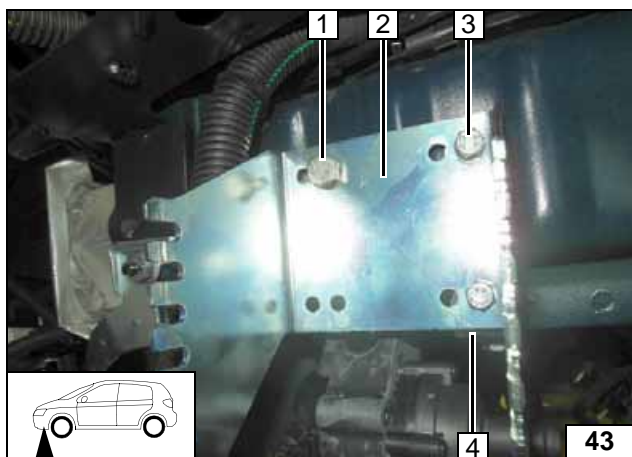

- 1 M8x25 bolt, spring lockwasher, loosely premount 5 mm shim
- 2 Bracket
- 3 M6x25 bolt, spring lockwasher, loosely premount 5 mm shim
- 4 Premounted angle bracket

Installing bracket

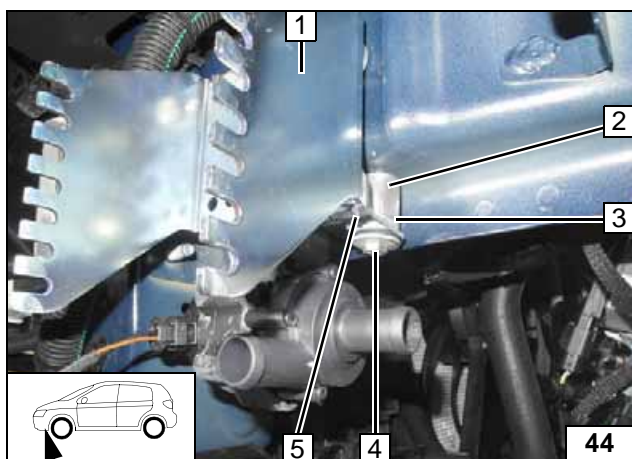

- 1 Bracket
- 2 20mm shim
- 3 5 mm shim
- 4 M6x40 bolt, spring lockwasher, large diameter washer
- 5 Premounted angle bracket

Align bracket and tighten also premounted bracket bolts.

Installing bracket

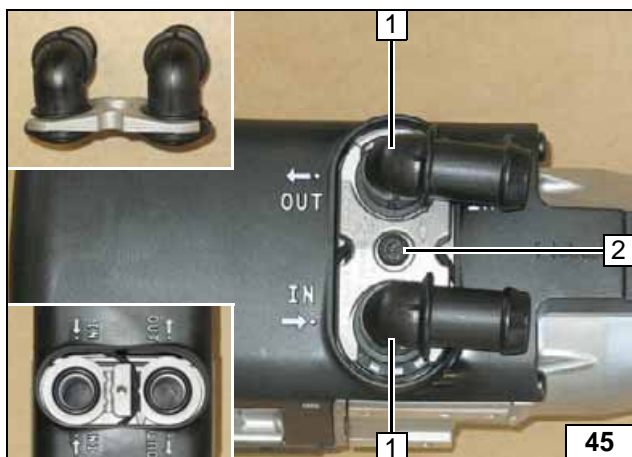

Preparing Heater

- 1 Water connection piece, sealing ring [2x each]
- 2 5x15 self-tapping bolt, retaining plate of water connection pieces

Installing water connection pieces



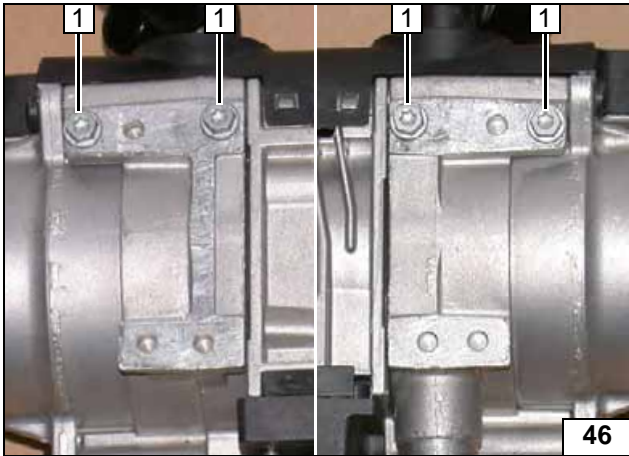
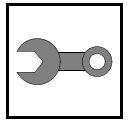

Screw 5x13 self-tapping bolts 1 [4x] into existing holes by a maximum of 3 thread turns.



Premounting bolts loosely

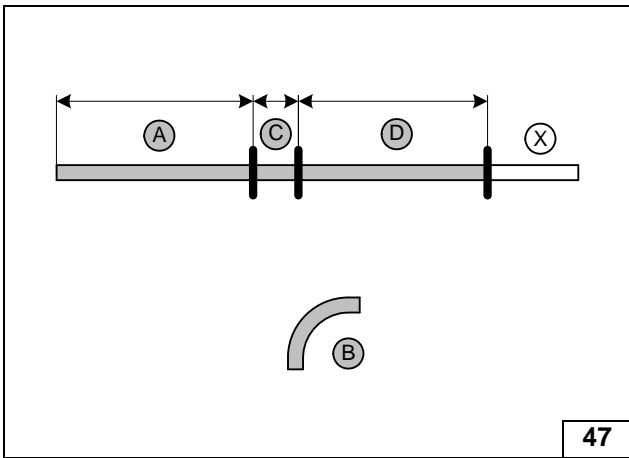

1.6 Petrol and 1.6 Diesel

Discard section X.
Hose B = 18mm dia., 90° moulded hose

- A = 850
- C = 60
- D = 850



Cutting hoses to length

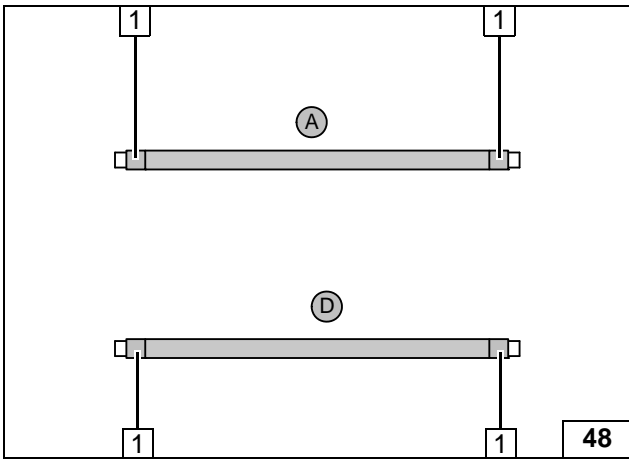

Push braided protection hoses onto hoses A and D and cut to length. Cut heat shrink plastic tubing to size.

- 1 50 mm long heat shrink plastic tubing [4x]



Preparing hoses

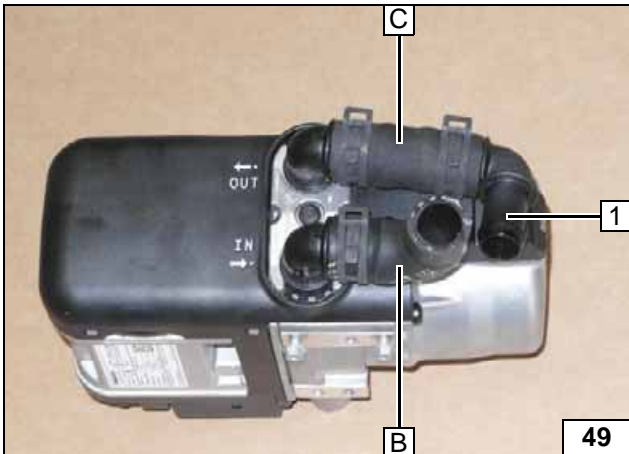

All spring clips = 25 mm dia.

- 1 90°, 18x18mm connecting pipe



Premounting hoses

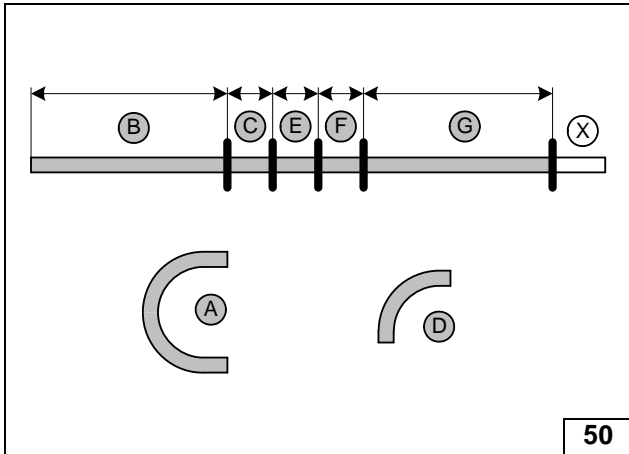
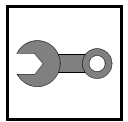

2.0 Diesel

Discard section X.

Hose A = 18mm dia., 180° moulded hose

Hose D = 18mm dia., 90° moulded hose

- B = 870
- C = 60
- E = 60
- F = 60
- G = 830



Cutting hoses to length

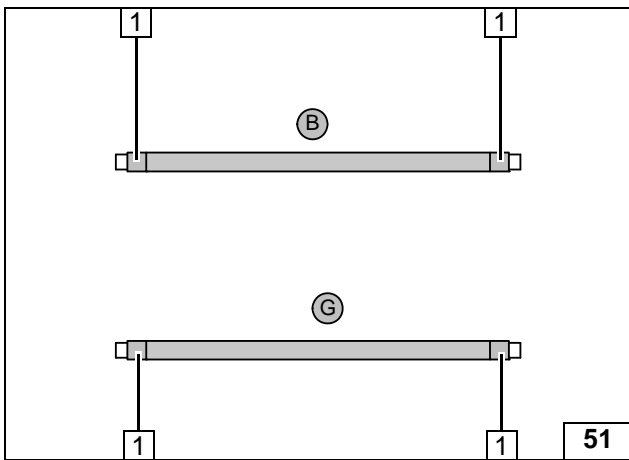

Push braided protection hoses onto hose B and G and cut to length. Cut heat shrink plastic tubing to size.

- 1 50 mm long heat shrink plastic tubing [4x]



Preparing hoses

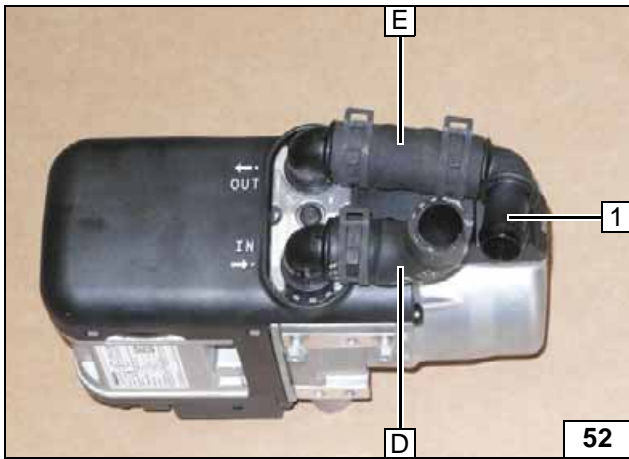

All spring clips = 25 mm dia.

- 1 90°, 18x18mm connecting pipe



Premounting hoses

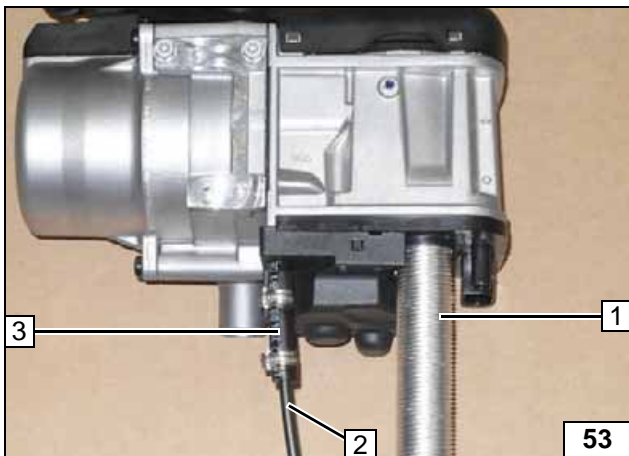

All vehicles

- 1 Combustion air pipe
- 2 Fuel line
- 3 Hose section, 10mm dia.clamp [2x]

Premounting combustion air pipe and fuel line

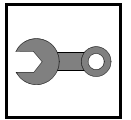

Installing Heater

- 1 Tighten 5x13 self-tapping bolt [4x] (the 2 front bolts are covered)

Mounting heater

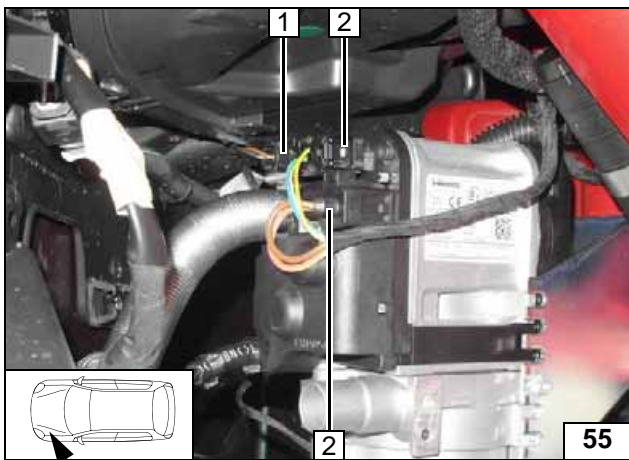

- 1 Wiring harness of circulating pump
- 2 Wiring harness of heater [2x]

Installing wiring harnesses

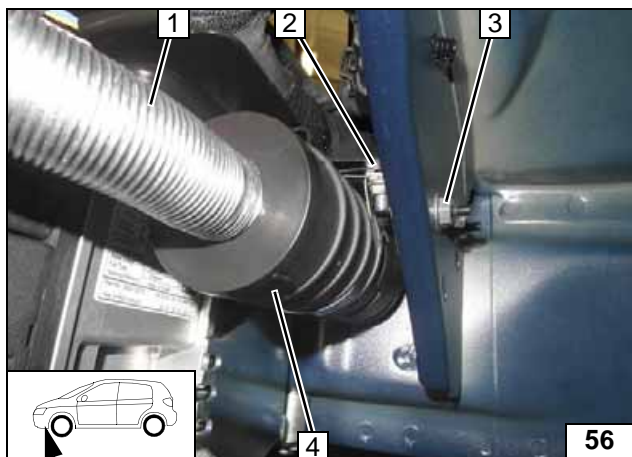
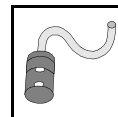

Combustion Air

Vehicle with retaining bracket and stud bolts at position 3

- 1 Combustion air pipe
- 2 M5x16 bolt, large diameter washer, original vehicle hole, clamp 51mm dia., flanged nut
- 4 Silencer



**Mounting
silencer**

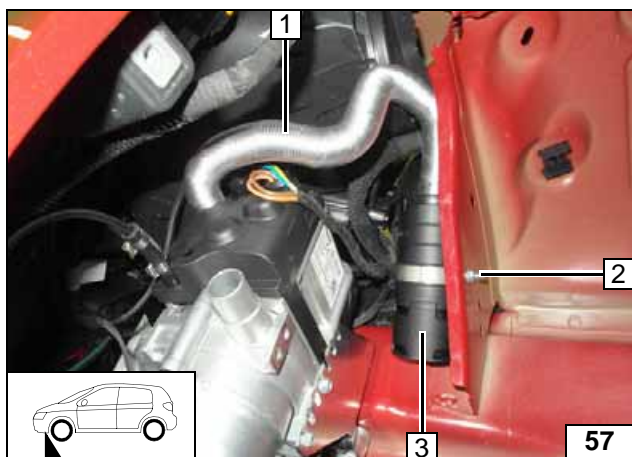

Vehicle without retaining bracket and stud bolts

- 1 Combustion air pipe
- 2 M5x16 bolt, large diameter washer, original vehicle hole, clamp 51mm dia., flanged nut
- 3 Silencer



**Mounting
silencer**

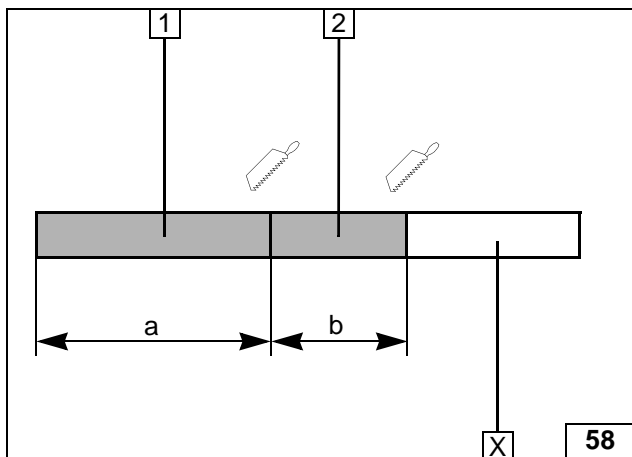
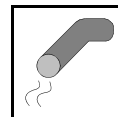

Exhaust Gas

Discard section **X**.

- 1 Exhaust pipe
a = 300
- 2 Exhaust end section
b = 300



Preparing exhaust pipe

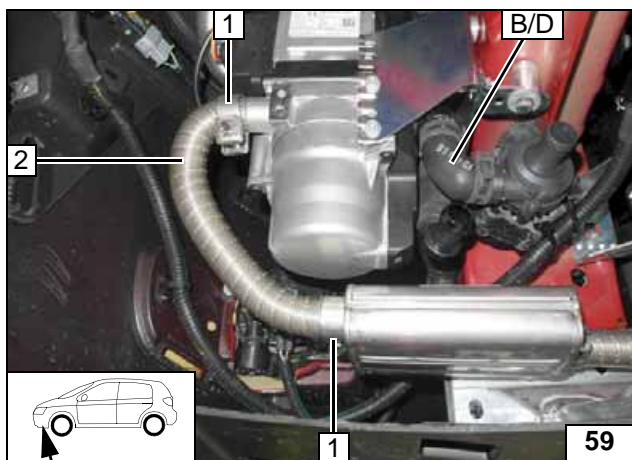

Hose **B** = 1.6 Petrol and Diesel
Hose **D** = 2.0 Diesel

Connect hose **B/D** to circulating pump using a 25mm dia. spring clip.

- 1 Hose clamp [2x]
- 2 Exhaust pipe



Installing exhaust pipe

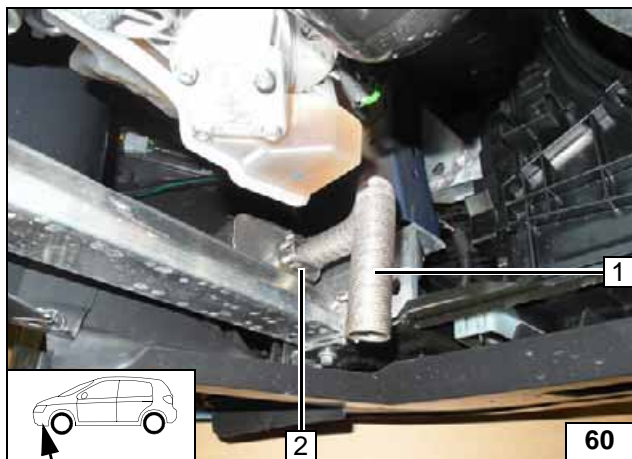

Ensure sufficient distance to neighbouring components; correct if necessary.

- 1 Exhaust end section
- 2 Hose clamp



Installing exhaust end section





Coolant Circuit Petrol

WARNING!

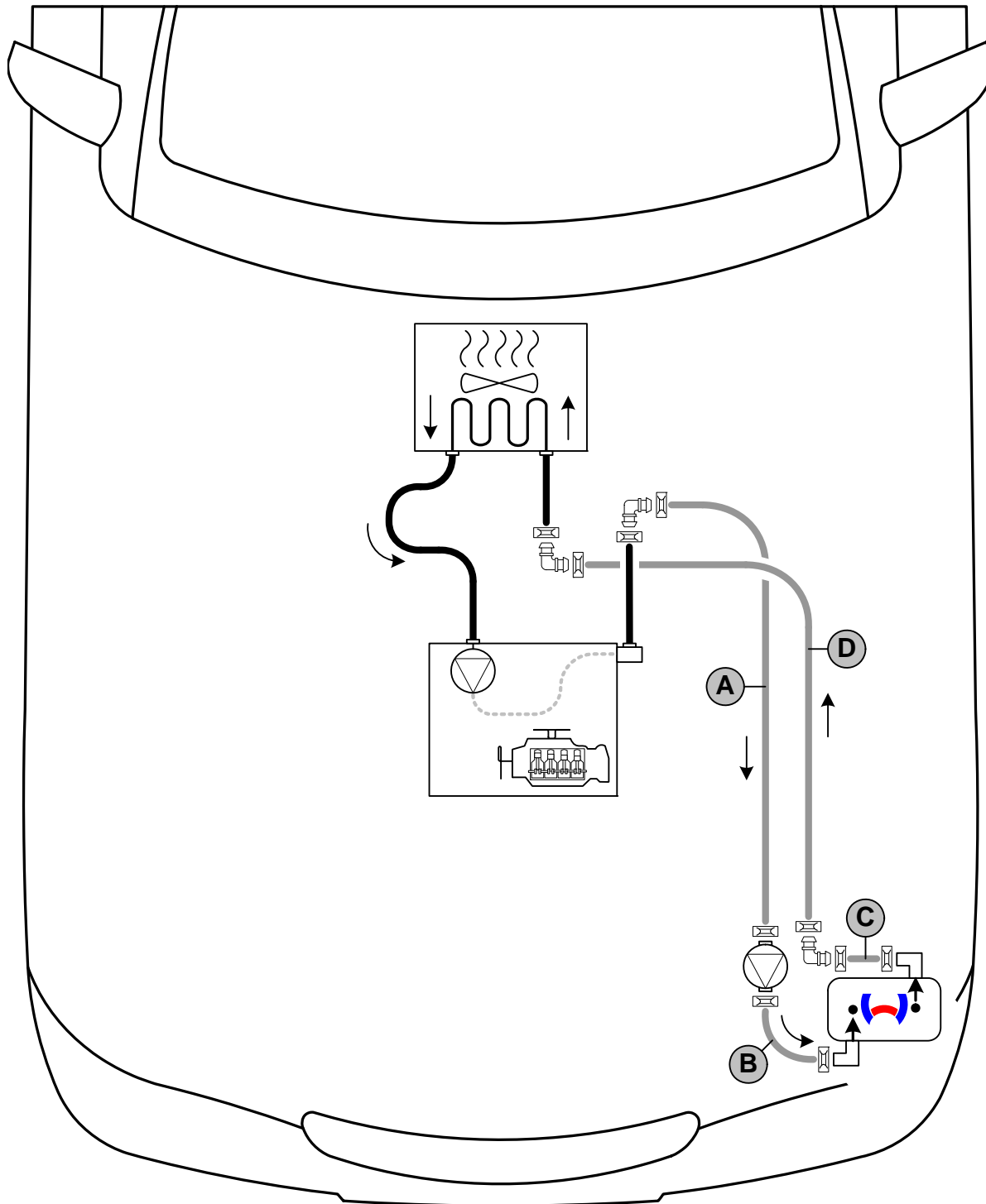
Any coolant running off should be collected in an appropriate container. Route hoses so that they are kink-free. Unless specified otherwise, always fasten using cable ties. Position clamps so that other hoses cannot be damaged. When installing the hoses, the heater must be filled with coolant. The connection should be "inline" based on the following diagram:



Hose routing diagram

All spring clips  = 25 mm dia.
 All connecting pipes  = 18x18 mm dia.



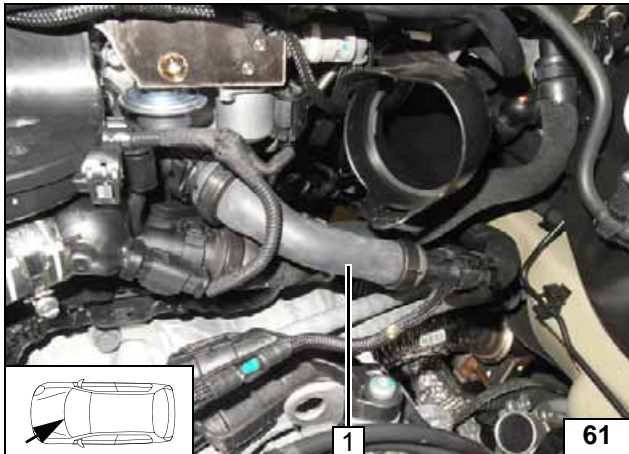

Remove hose 1 from engine outlet/heat exchanger inlet.



Cutting point

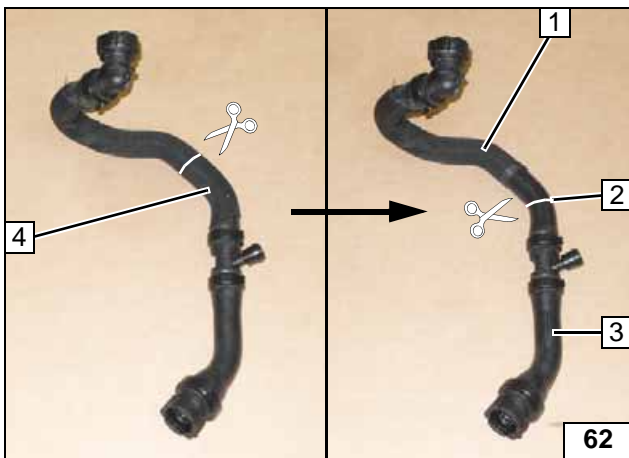

Remove protective hose 4.

- 1 Hose section of heat exchanger inlet
- 2 Cutting point
- 3 Hose section of engine outlet



Cutting point

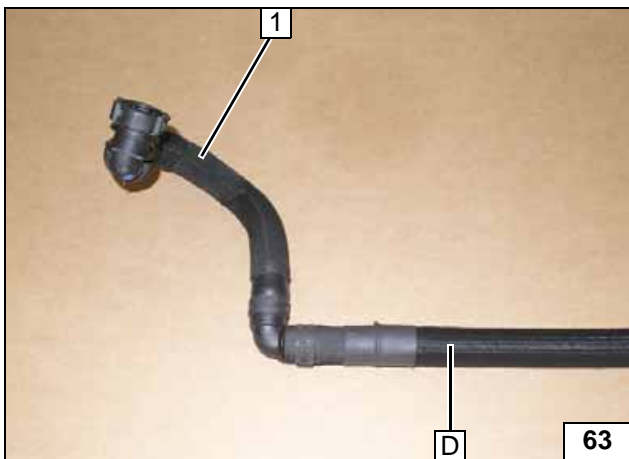

1 Hose of heat exchanger inlet

Premounting hose D

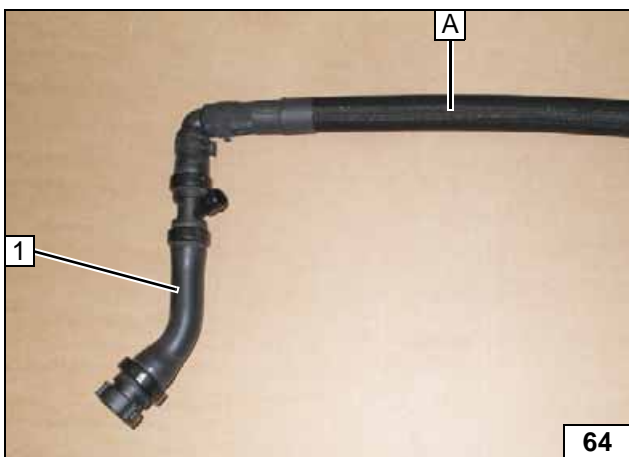

1 Hose of engine outlet

Premounting hose A

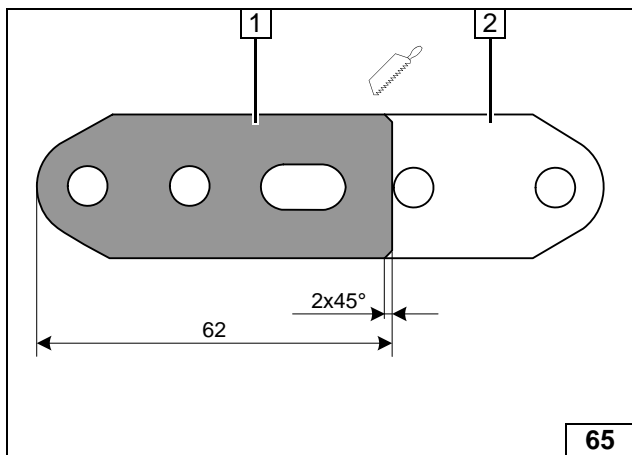

- 1 Perforated bracket
- 2 Discard section



Preparing perforated bracket

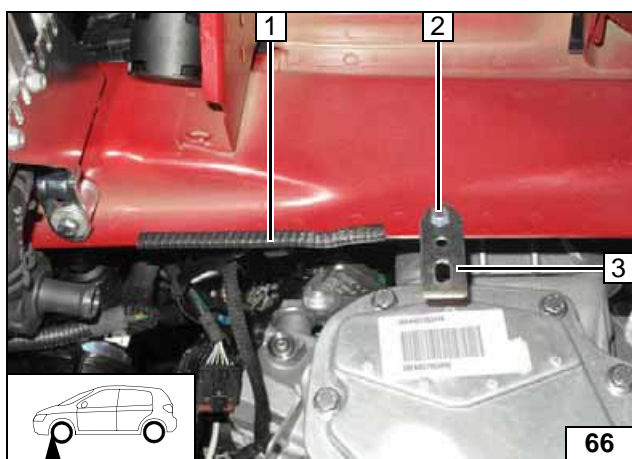

- 1 200 mm edge protection
- 2 M6x16 bolt, flanged nut
- 3 Perforated bracket

Installing perforated bracket

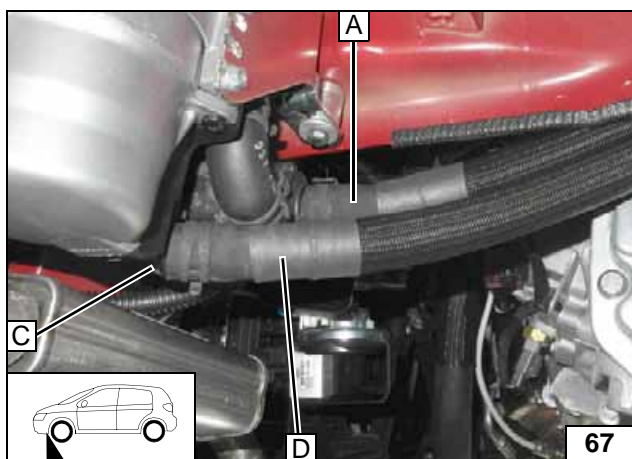

Connect hose **A** to circulating pump. Connect hoses **C** and **D**.



**Connect-
ing heater**

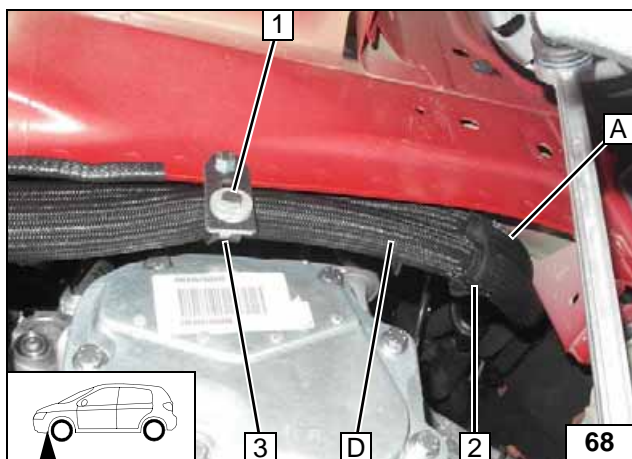

- 1 M6x16 bolt, large diameter washer, flanged nut
- 2 23x23 lockable hose bracket
- 3 38 mm dia. rubber-coated p-clamp

**Routing in
engine
compartment**

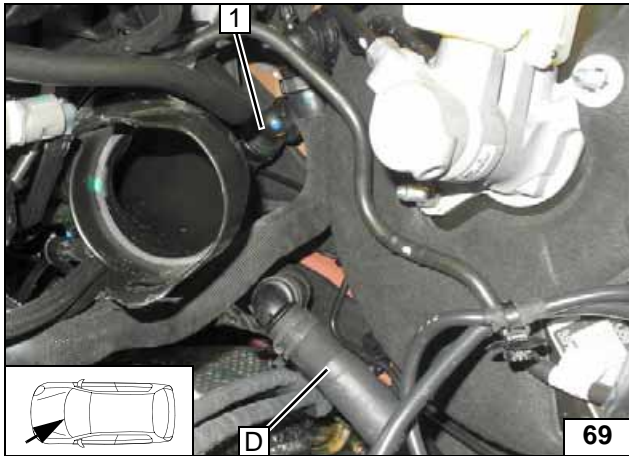

- 1 Coupling piece on heat exchanger inlet connection piece

Connect-
ing heat ex-
changer
inlet

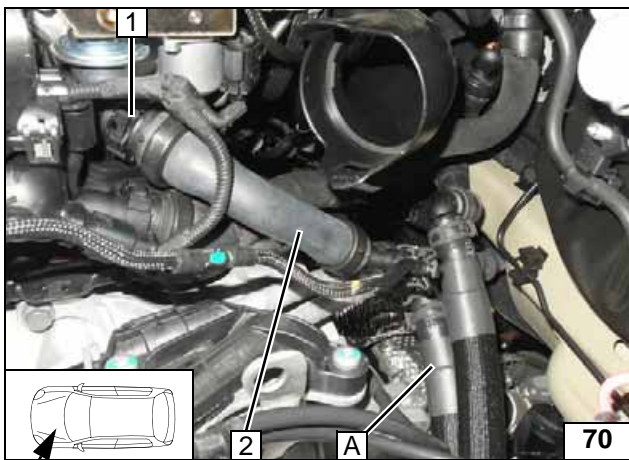

- 1 Coupling piece on engine outlet connection piece
- 2 Hose of engine outlet

Connect-
ing engine
outlet

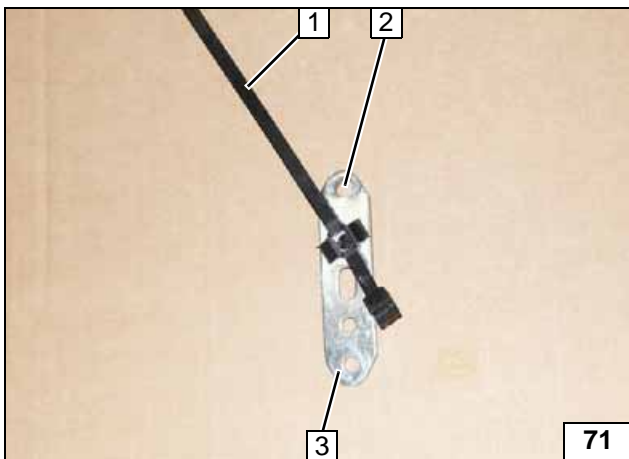

Drill out perforated bracket 3 at position 2 to 8.5mm dia.



- 1 Clip-type cable tie

Preparing
perforated
bracket

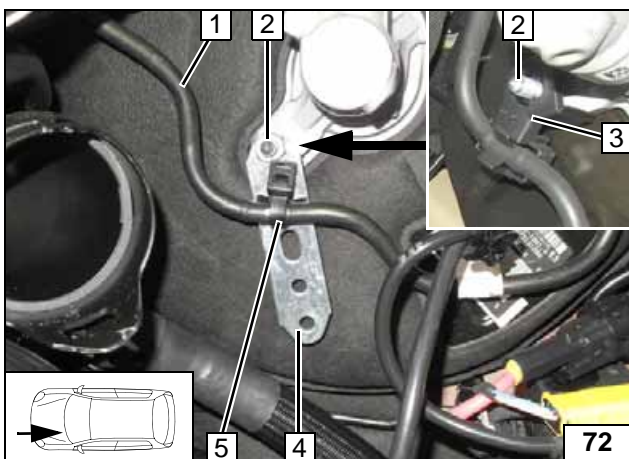

Remove original vehicle vacuum line bracket 3 at position 2 and discard.



- 1 Vacuum line
- 2 Original vehicle stud bolt, flanged nut
- 4 Perforated bracket
- 5 Close clip-type cable tie

Installing
perforated
bracket

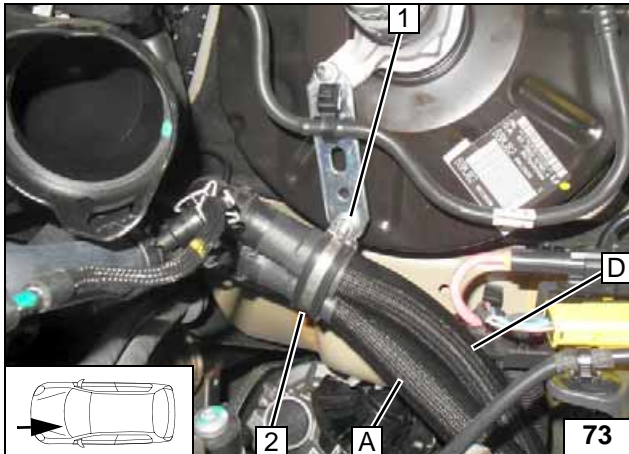

- 1 M6x20 bolt, flanged nut
- 2 38 mm dia. rubber-coated p-clamp

Routing in engine compartment

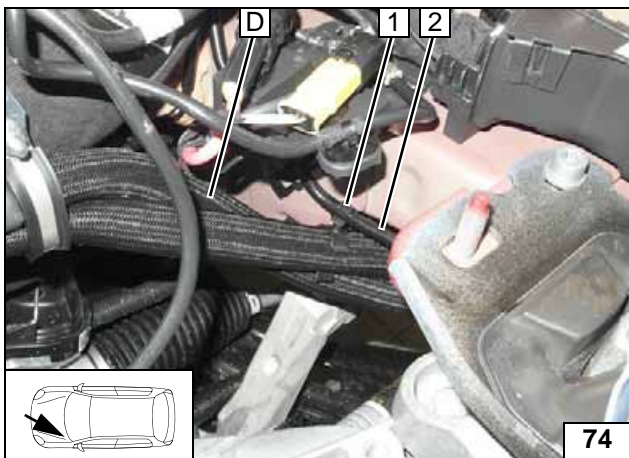

Align hoses. Ensure sufficient distance to neighbouring components; correct if necessary.

- 1 9x23 hose bracket rotatable
- 2 Original vehicle coupling line



Installing hose bracket





Coolant Circuit 1.6 Diesel

WARNING!

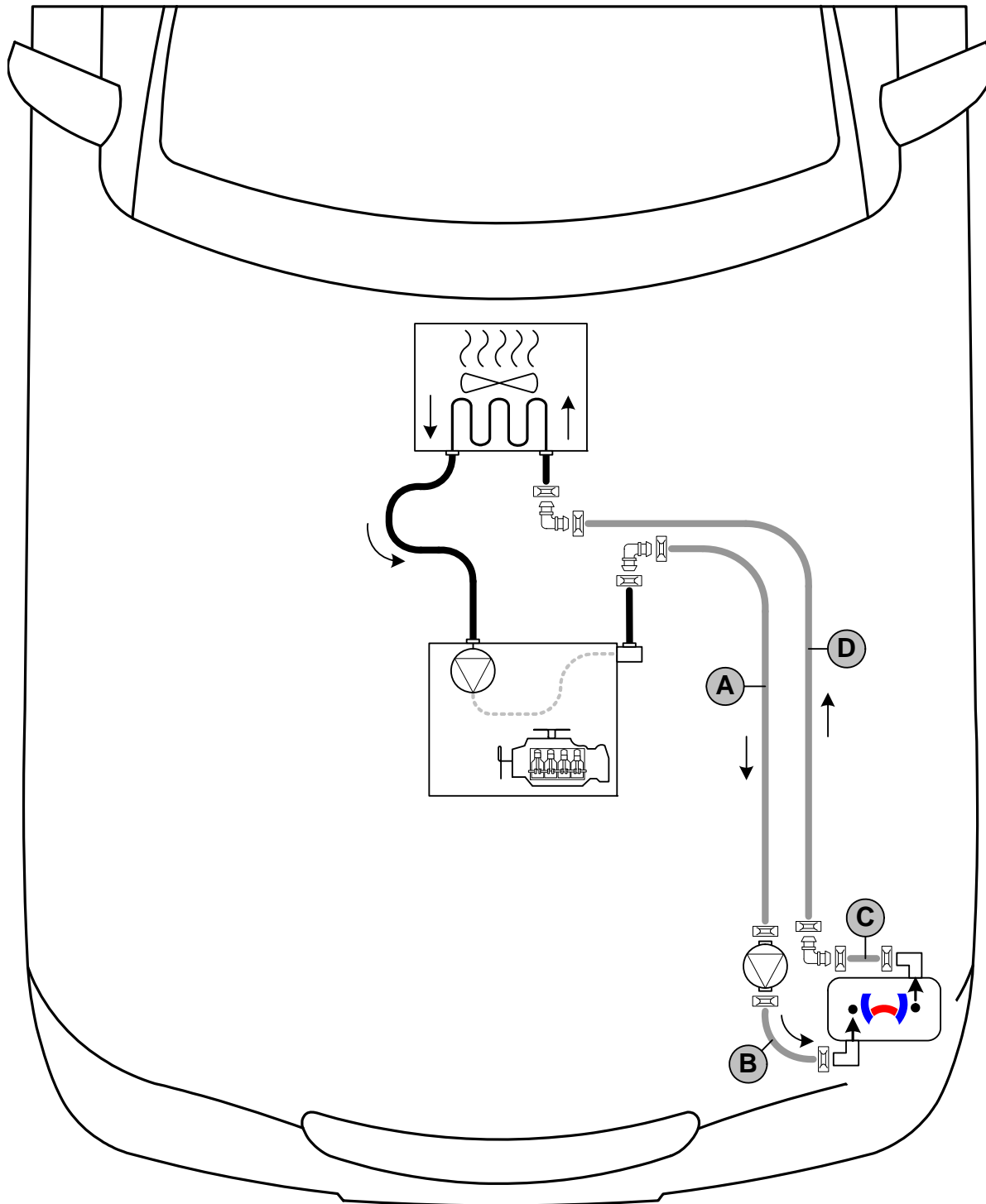
Any coolant running off should be collected in an appropriate container. Route hoses so that they are kink-free. Unless specified otherwise, always fasten using cable ties. Position clamps so that other hoses cannot be damaged. When installing the hoses, the heater must be filled with coolant. The connection should be "inline" based on the following diagram:



Hose routing diagram

All spring clips  = 25 mm dia.
 All connecting pipes  = 18x18 mm dia.





Remove hose 1 from engine outlet/heat exchanger inlet.



Cutting point

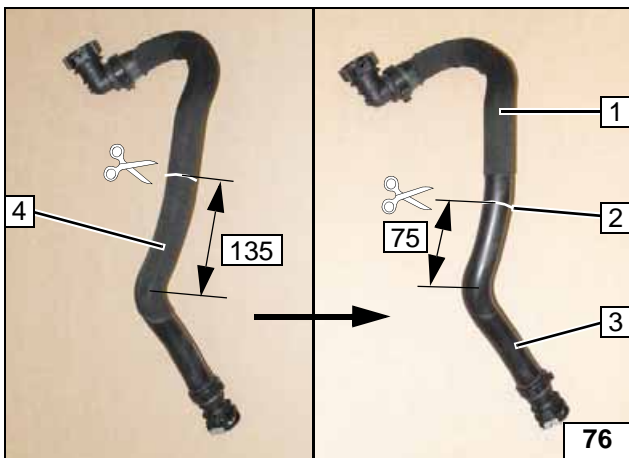

Remove protective hose 4.



- 1 Hose section of heat exchanger inlet
- 2 Cutting point
- 3 Hose section of engine outlet

Cutting point

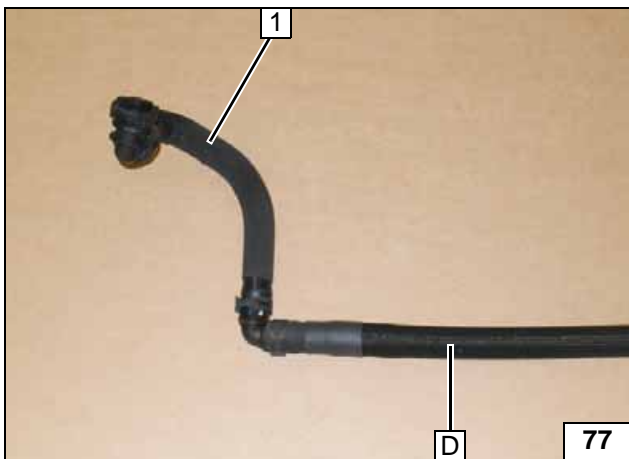

1 Hose of heat exchanger inlet

Premounting hose D

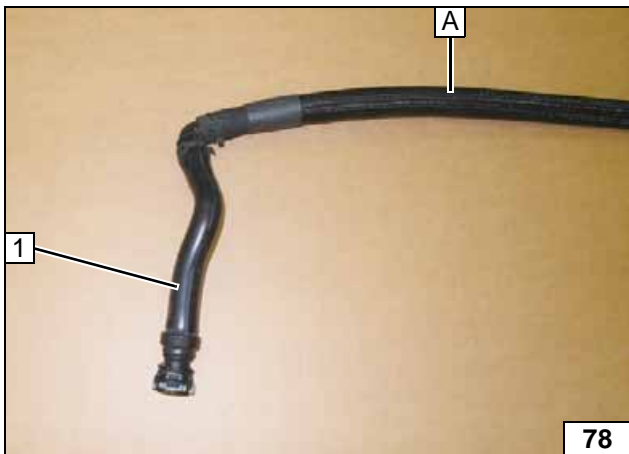

1 Hose of engine outlet

Premounting hose A

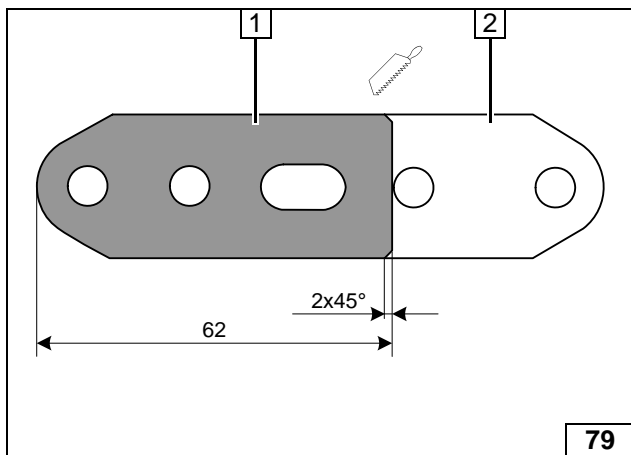

- 1 Perforated bracket
- 2 Discard section



Preparing perforated bracket

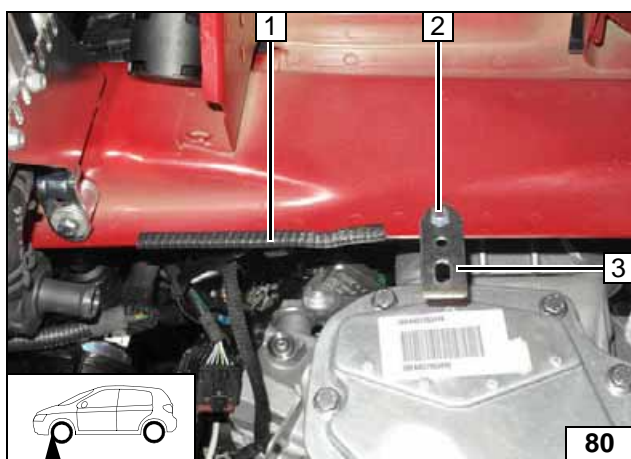

- 1 200 mm edge protection
- 2 M6x16 bolt, flanged nut
- 3 Perforated bracket

Installing perforated bracket

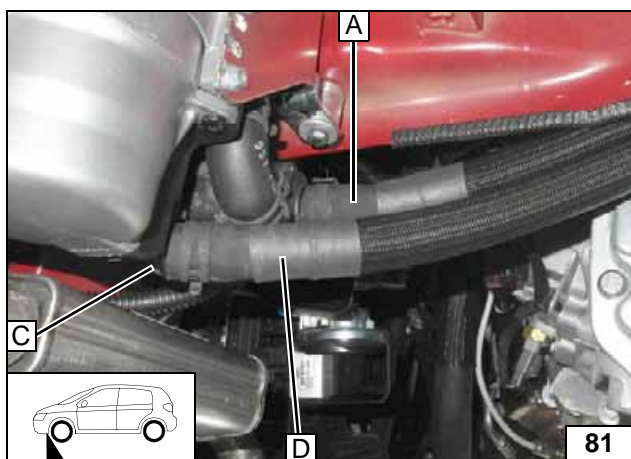

Connect hose **A** to circulating pump. Connect hoses **C** and **D**.



**Connect-
ing heater**

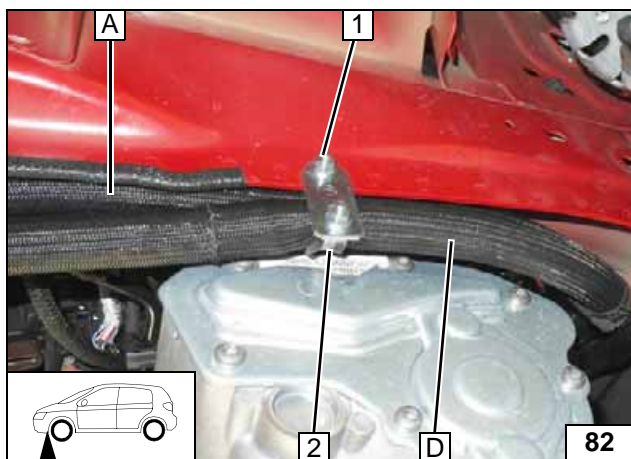

- 1 M6x16 bolt, large diameter washer, flanged nut
- 2 38 mm dia. rubber-coated p-clamp

**Routing in
engine
compartment**

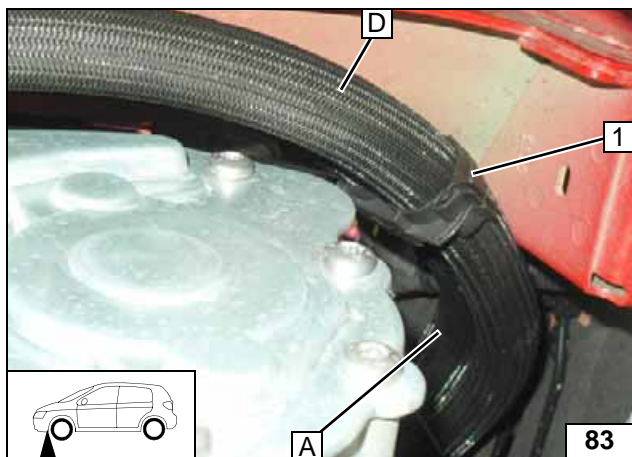

Ensure sufficient distance between hoses as well as rubber-coated p-clamps and transmission (min. 20mm), correct if necessary.



- 1 23x23 lockable hose bracket

Mounting hose bracket

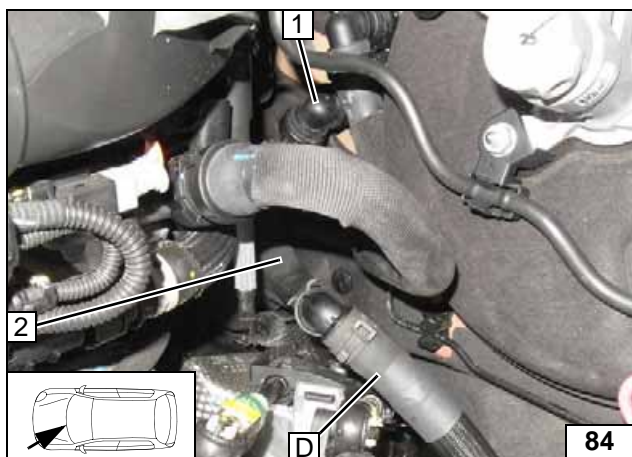

- 1 Coupling piece on heat exchanger inlet connection piece
- 2 Hose of heat exchanger inlet

Connecting heat exchanger inlet

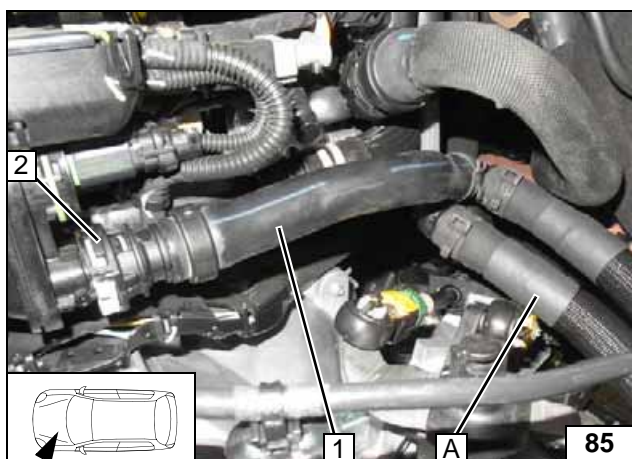

- 1 Hose of engine outlet
- 2 Coupling piece on engine outlet connection piece

Connecting engine outlet

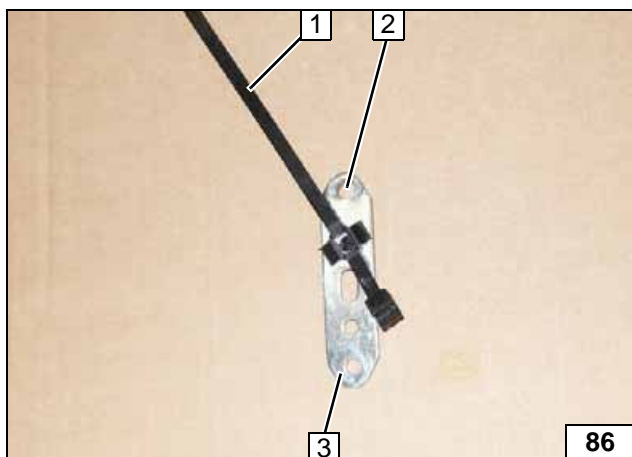

Drill out perforated bracket 3 at position 2 to 8.5mm dia.



- 1 Clip-type cable tie

Preparing perforated bracket

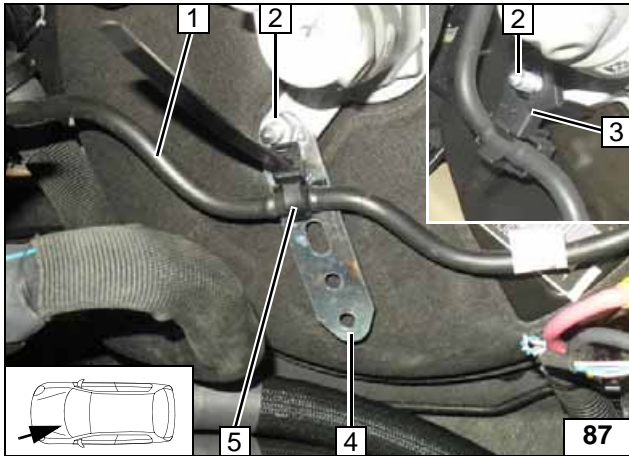

Remove original vehicle vacuum line bracket **3** at position **2** and discard.



- 1 Vacuum line
- 2 Original vehicle stud bolt, flanged nut
- 4 Perforated bracket
- 5 Close clip-type cable tie

Installing perforated bracket

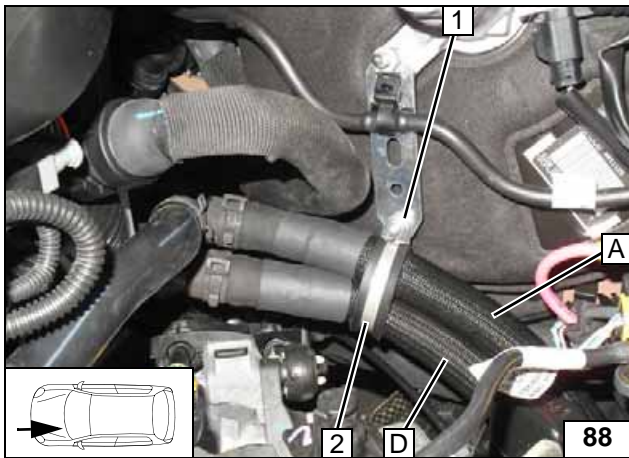

- 1 M6x20 bolt, flanged nut
- 2 38 mm dia. rubber-coated p-clamp

Routing in engine compartment

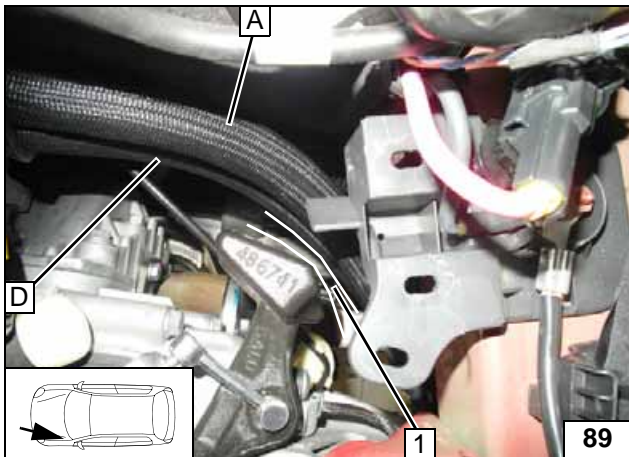

Ensure sufficient distance between hoses and gear change lever at position **1** (min. 20mm), correct if necessary.



Aligning hoses

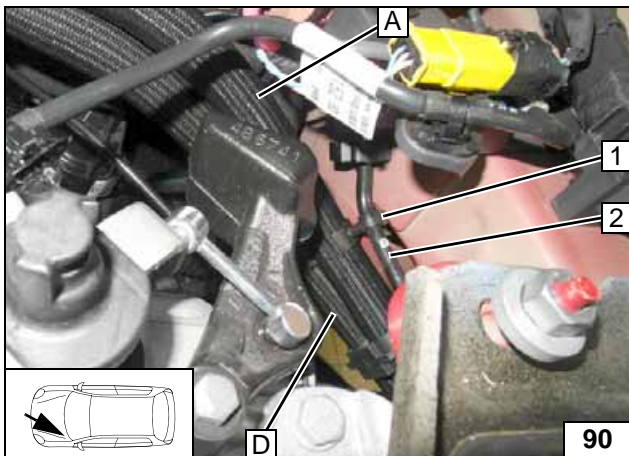

Align hoses. Ensure sufficient distance to neighbouring components; correct if necessary.



- 1 9x23 hose bracket rotatable
- 2 Original vehicle coupling line

Installing hose bracket





Cooland Circuit 2.0 Diesel

WARNING!

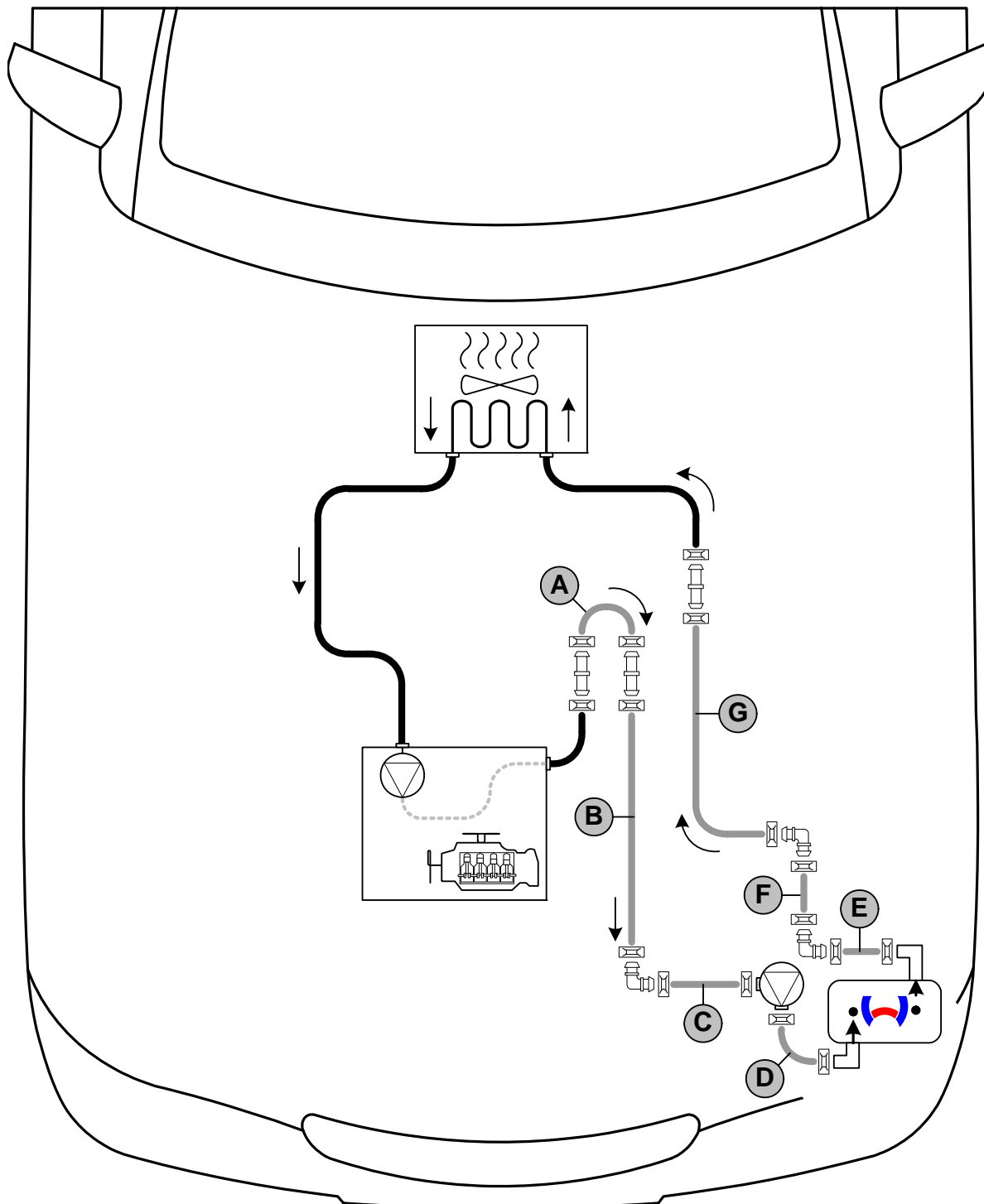
Any coolant running off should be collected in an appropriate container. Route hoses so that they are kink-free. Unless specified otherwise, always fasten using cable ties. Position clamps so that other hoses cannot be damaged. When installing the hoses, the heater must be filled with coolant. The connection should be "inline" based on the following diagram:



Hose routing diagram

All spring clips  = 25 mm dia.
 All connecting pipes  and  = 18x18 mm dia.



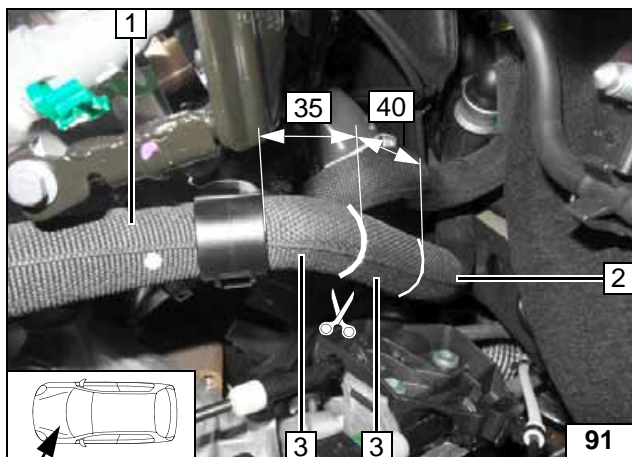

Cut off hose on engine outlet/heat exchanger inlet at marking. Remove hose section of engine outlet 1. Remove fabric protective hose 3 in the marked area.

2 Hose section of heat exchanger inlet

Cutting point

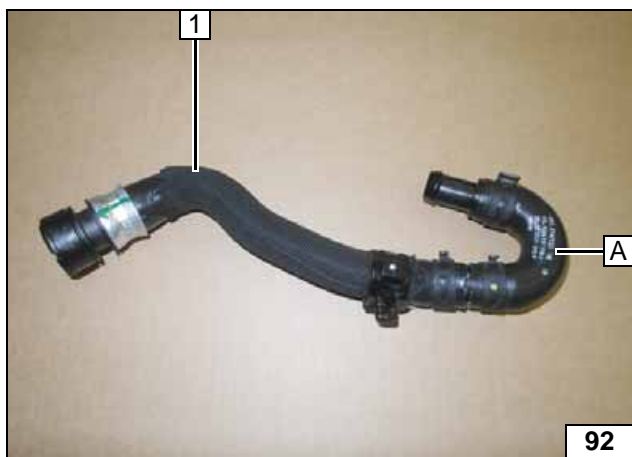

1 Hose of engine outlet

Premounting hose A



1 Angle bracket
2 M6x20 bolt, flanged nut
3 38 mm dia. rubber-coated p-clamp, preformed

Premounting rubber-coated p-clamp

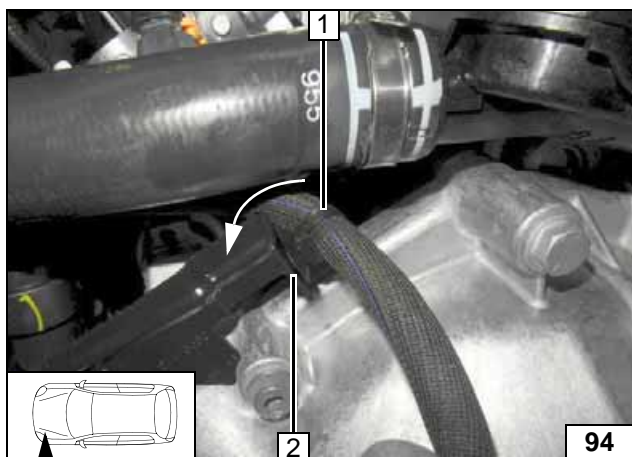

Remove clip 1 and discard. Twist tab at position 2 by 90°



Preparing installation location

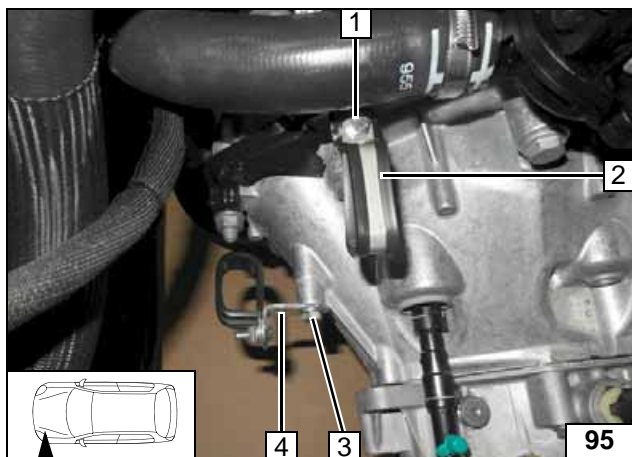

- 1 M6x20 bolt, flanged nut, existing hole
- 2 38 mm dia. rubber-coated p-clamp
- 3 M8x20 bolt, washer, existing threaded hole
- 4 Angle bracket with pre-mounted p-clamp

Preparing installation location

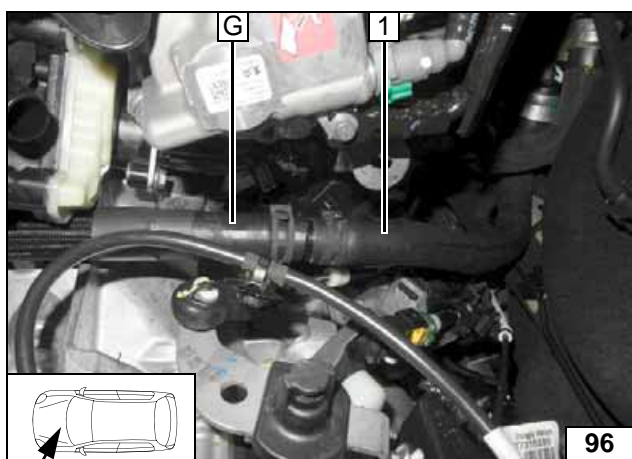

- 1 Hose of heat exchanger inlet

Connecting heat exchanger inlet

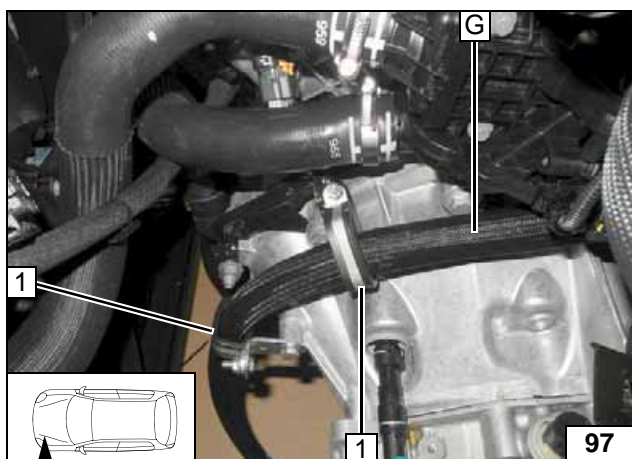

Route hose G through rubber-coated p-clamps 1 [2x].



Connecting heat exchanger inlet

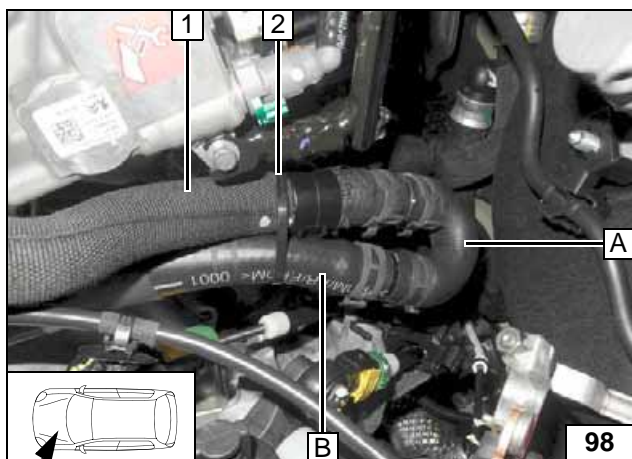

- 1 Hose engine outlet with coupling piece on engine outlet connection piece
- 2 Cable tie

Connecting engine outlet

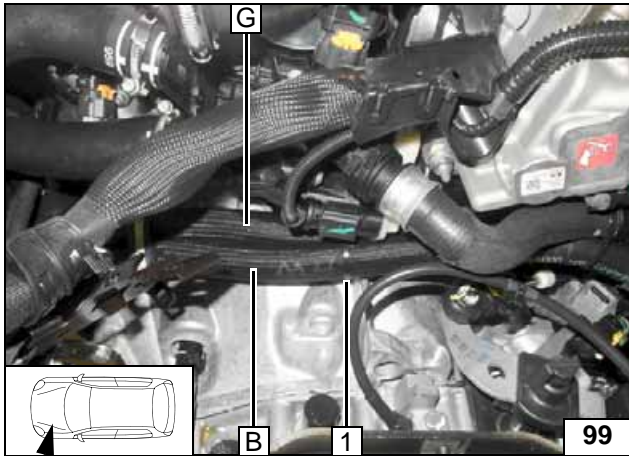

1 Cable tie

Routing in engine compartment

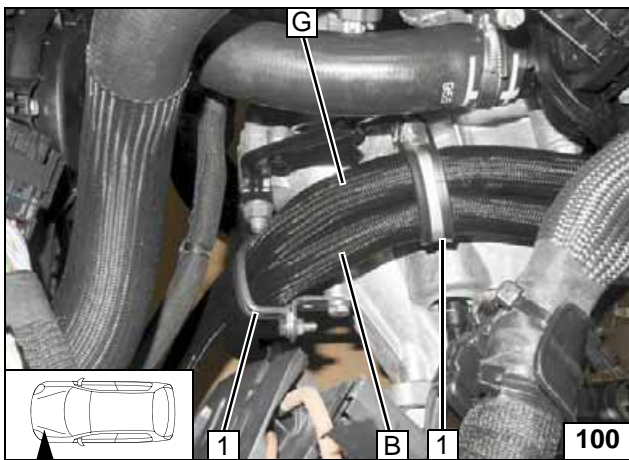

Route hoses **G** and **B** through rubber-coated p-clamps **1** [2x].



Routing in engine compartment

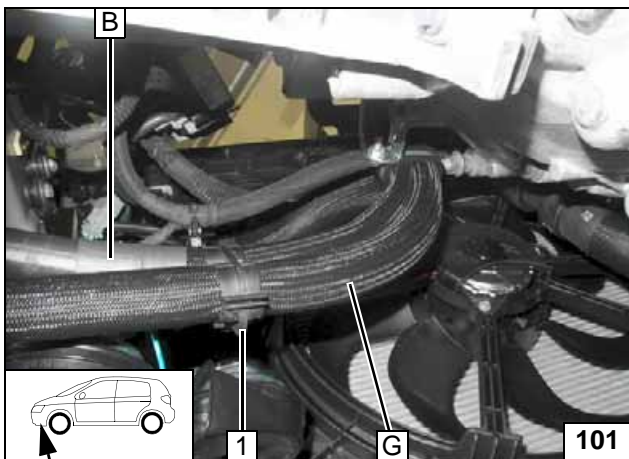

1 Mount hose bracket



Routing in engine compartment

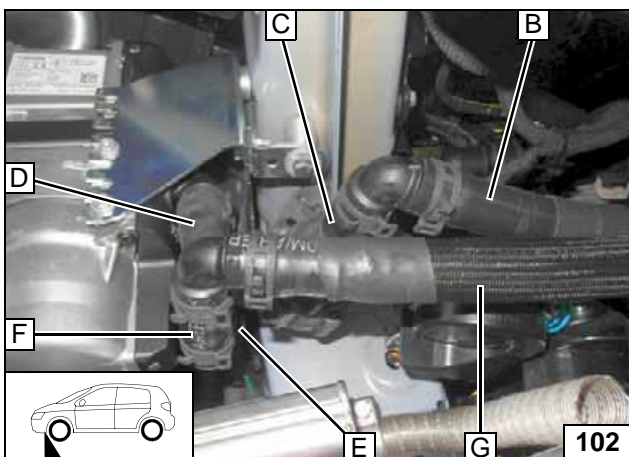

Connect hose **C** to circulating pump. Connect hose **E** and **F** (hose **E** through hose **D** hidden). Align hoses. Ensure sufficient distance to neighbouring components; correct if necessary.



Connecting heater

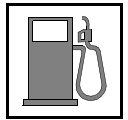

Fuel

CAUTION!

Open the vehicle's fuel tank cap, ventilate the tank and then re-close the tank lock.

Catch any fuel running off in an appropriate container.

Install fuel line and metering pump wiring harness so that they are protected against stone impact. Unless specified otherwise, always fasten using cable ties. Provide rub protection for fuel line and wiring harness in areas where there are sharp edges.

WARNING!

The fuel line and wiring harness are routed to the metering pump as shown in the wiring harness routing diagram.

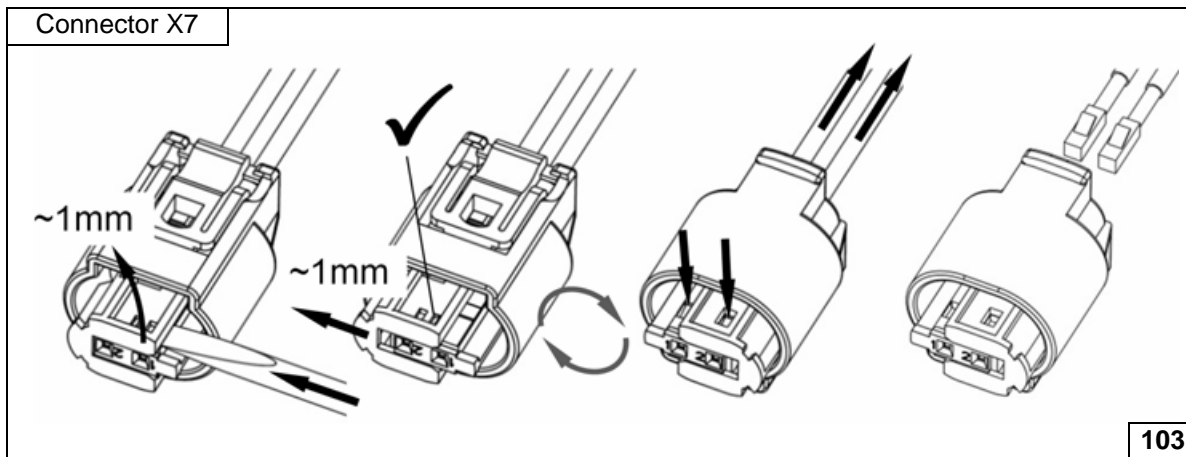

Dismantling connector of metering pump

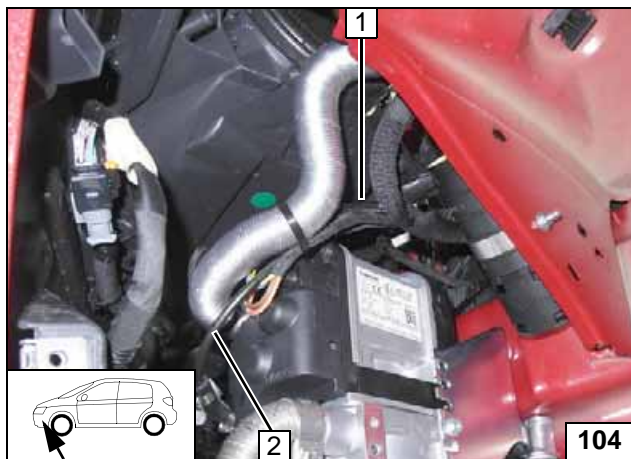

Pull fuel line 2 and wiring harness of metering pump into 10mm dia. corrugated tube 1 and route in engine compartment.



Routing lines



1 Fuel line and wiring harness of metering pump in 10mm dia. corrugated tube

Routing lines

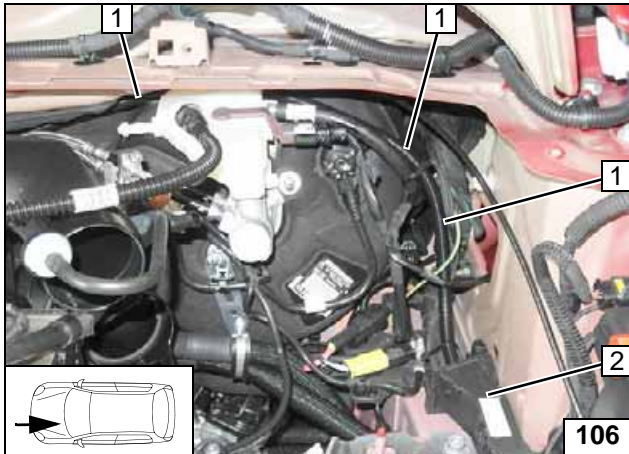
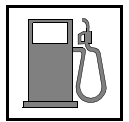

Route fuel line and wiring harness of metering pump in 10mm dia. corrugated tube 1 through original vehicle line duct 2 to firewall.



Routing lines

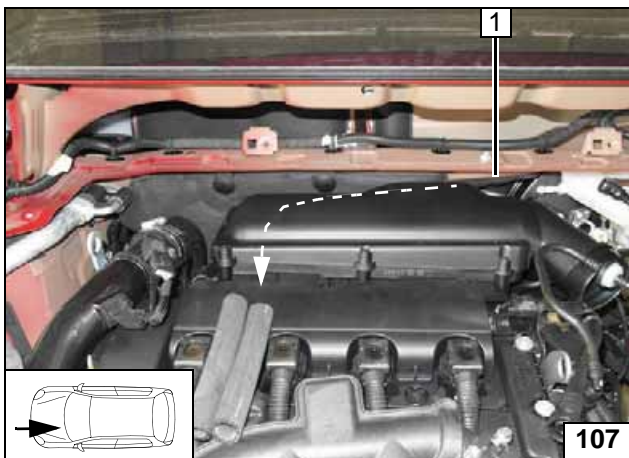

Route fuel line and wiring harness of metering pump in 10mm dia. corrugated tube 1 behind insulation mat to underbody.



Routing lines

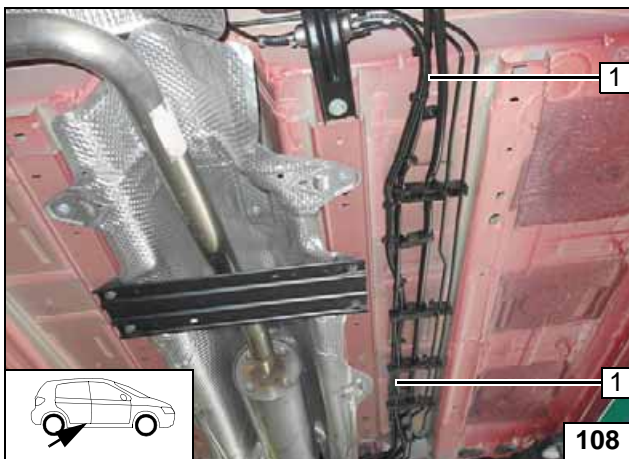

Route fuel line and wiring harness of metering pump in 10mm dia. corrugated tube 1 along original vehicle lines to installation location of metering pump.



Routing lines

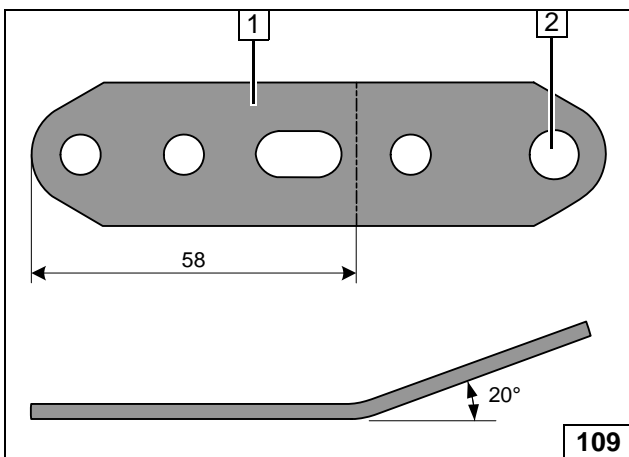

- 1 Perforated bracket
- 2 Drill out 8.5 mm dia. hole



Preparing perforated bracket

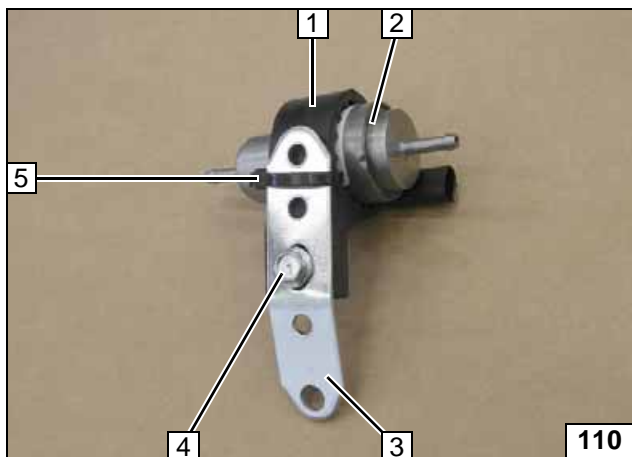
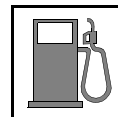

- 1 Mounting of metering pump
- 2 Metering pump
- 3 Perforated bracket
- 4 M6x25 bolt, support angle bracket, flanged nut
- 5 Cable tie

Premounting metering pump

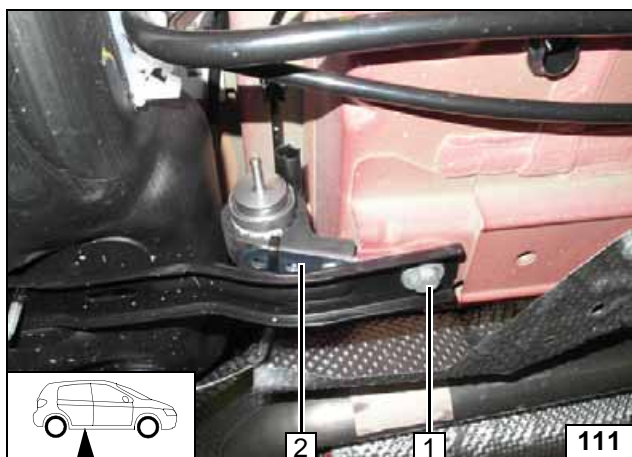

- 1 Original vehicle bolt
- 2 Metering pump



Mounting metering pump

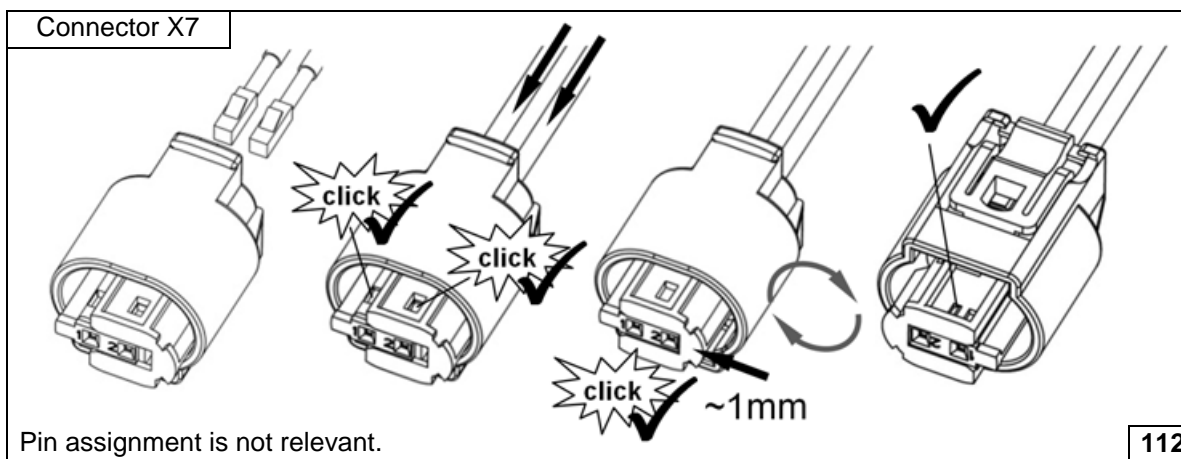

Completing connector of metering pump

Pin assignment is not relevant.

112

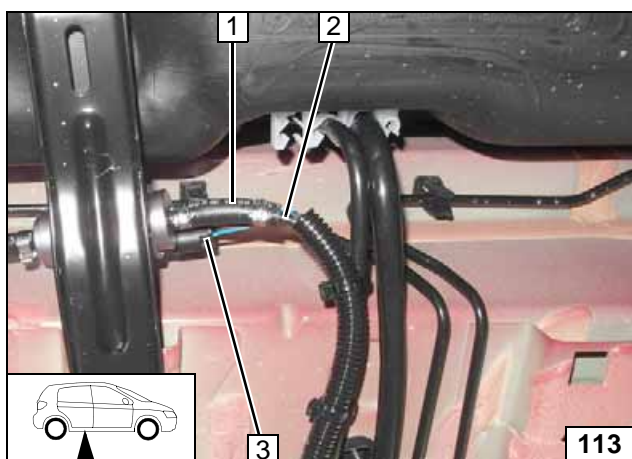

- 1 Hose section, 10mm dia.clamp [2x]
- 2 Fuel line of heater
- 3 Wiring harness of metering pump, connector X7 mounted



Connecting metering pump

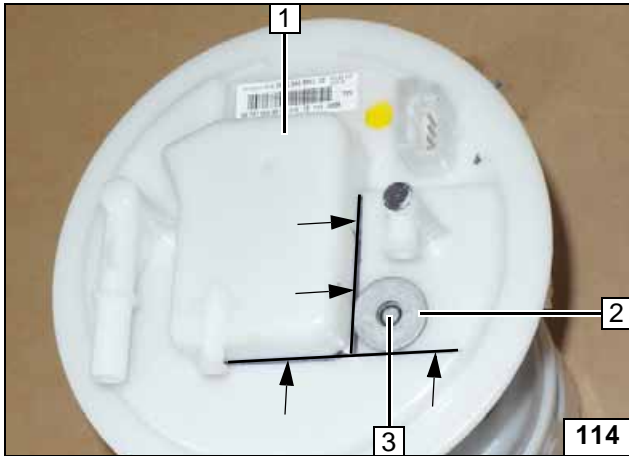
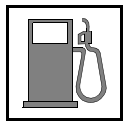

Petrol

Remove fuel-tank sending unit **1** in accordance with the manufacturer's instructions. Place large diameter washer with outer dia. $d_a = 21.6\text{mm}$ **2** on the markings.

3 Copy hole pattern, 6mm dia. hole



Fuel extraction

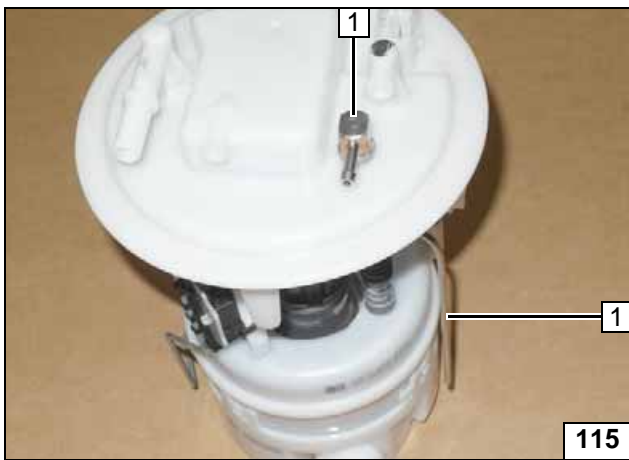

Shape fuel standpipe **1** according to template and cut it to length.



Installing fuel standpipe

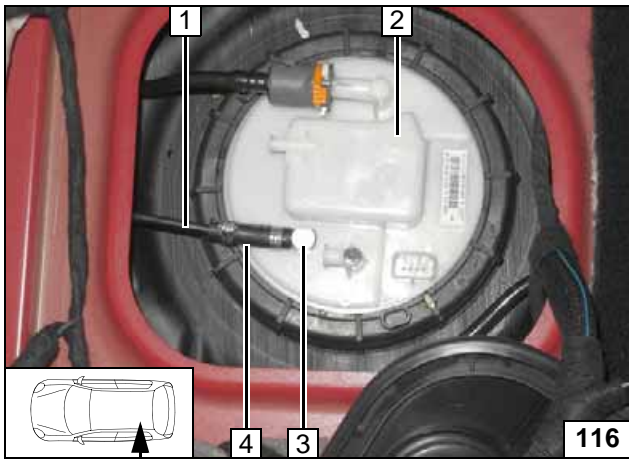

Install fuel-tank sending unit **2** in accordance with the manufacturer's instructions.

- 1** Fuel line
- 3** Fuel standpipe
- 4** Hose section, 10mm dia.clamp [2x]



Connecting fuel line

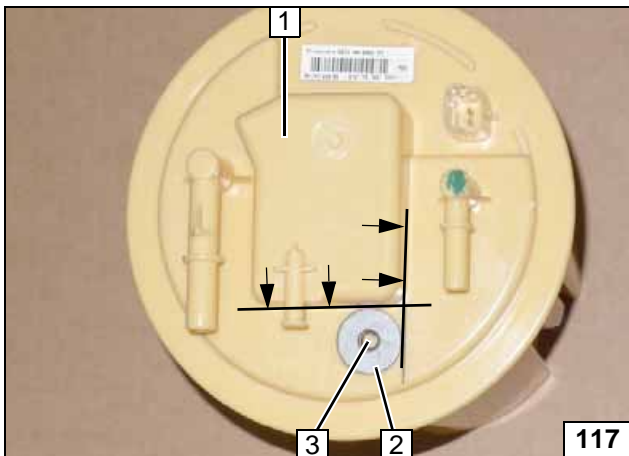

1.6 Diesel

Remove fuel-tank sending unit **1** in accordance with the manufacturer's instructions. Place large diameter washer with outer dia. $d_a = 21.6\text{mm}$ **2** on the markings.

3 Copy hole pattern, 6mm dia. hole



Fuel extraction

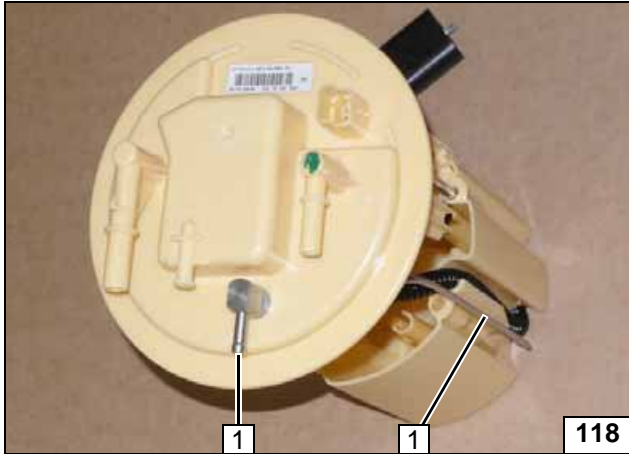
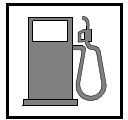

Shape fuel standpipe 1 according to template and cut it to length.



Installing fuel stand-pipe

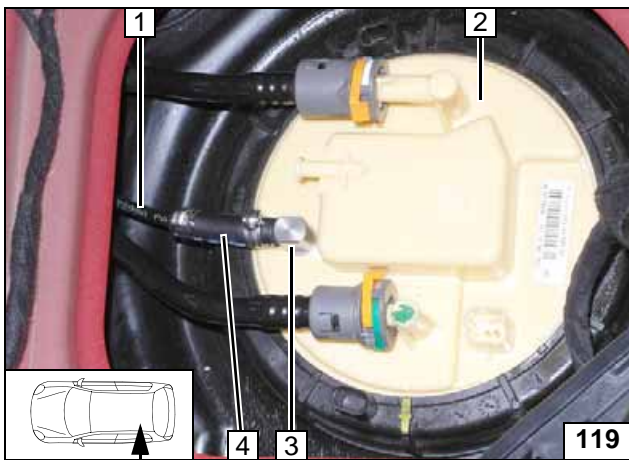

Install fuel-tank sending unit 2 in accordance with the manufacturer's instructions.



- 1 Fuel line
- 3 Fuel standpipe
- 4 Hose section, 10mm dia.clamp [2x]

Connect-ing fuel line

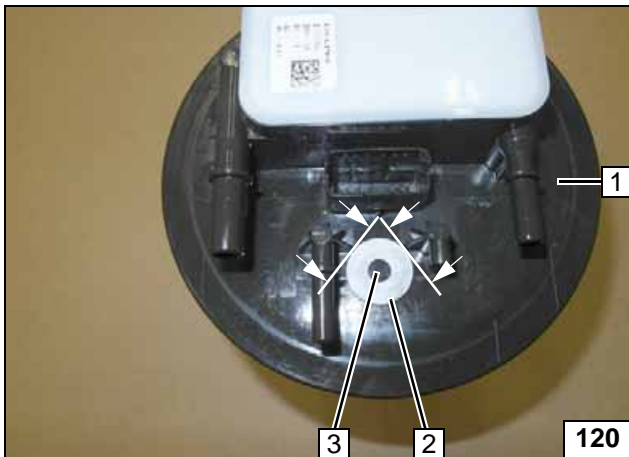

2.0 Diesel

Remove fuel-tank sending unit 1 in accordance with the manufacturer's instructions. Place large diameter washer with outer dia. $d_a = 21.6\text{mm}$ 2 on the markings.



Fuel ex-traction

- 3 Copy hole pattern, 6mm dia. hole

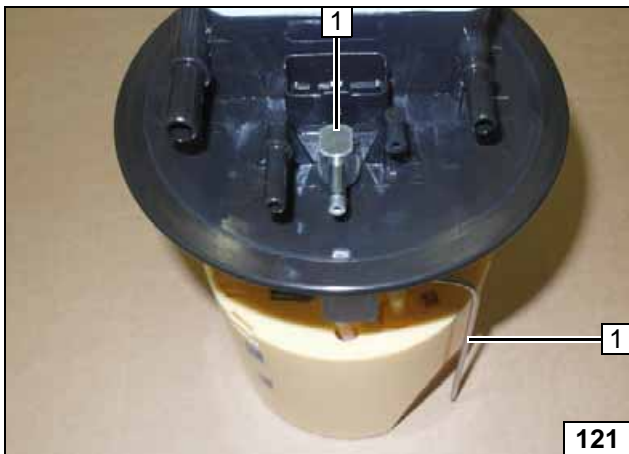

Shape fuel standpipe 1 according to template and cut it to length.



Installing fuel stand-pipe

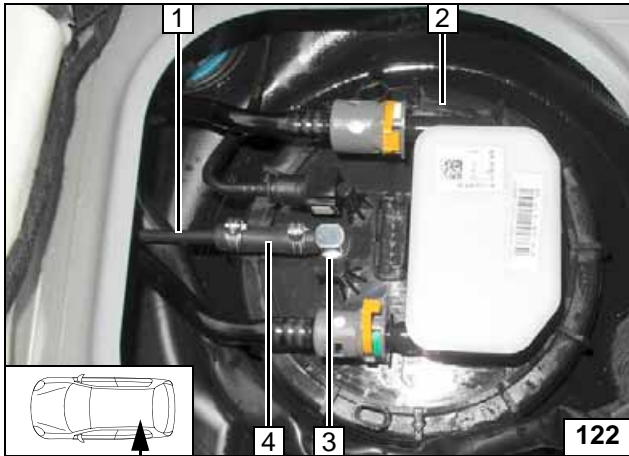
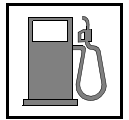

Install fuel-tank sending unit **2** in accordance with the manufacturer's instructions.



- 1 Fuel line
- 3 Fuel standpipe
- 4 Hose section, 10mm dia.clamp [2x]

**Connect-
ing fuel line**

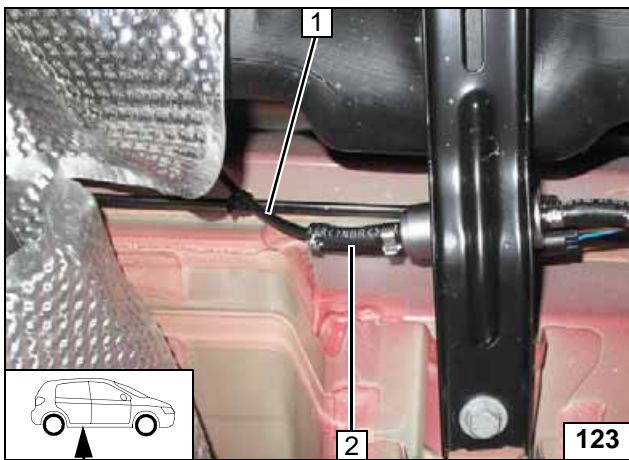

All vehicles

Check the position of the components; adjust if necessary. Check that they have freedom of movement.



- 1 Fuel line of fuel standpipe
- 2 Hose section, 10mm dia.clamp [2x]

**Connect-
ing meter-
ing pump**

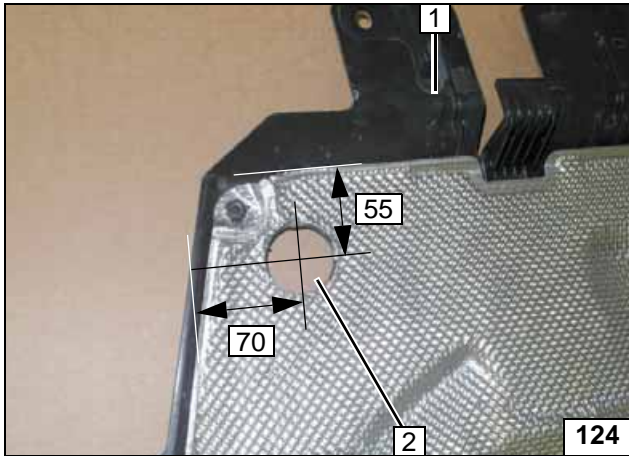
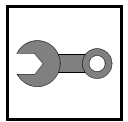

Final Work

- 1 Lower engine cover
- 2 Hole (according to work step 1 of the installation instructions)



Hole in underride protection

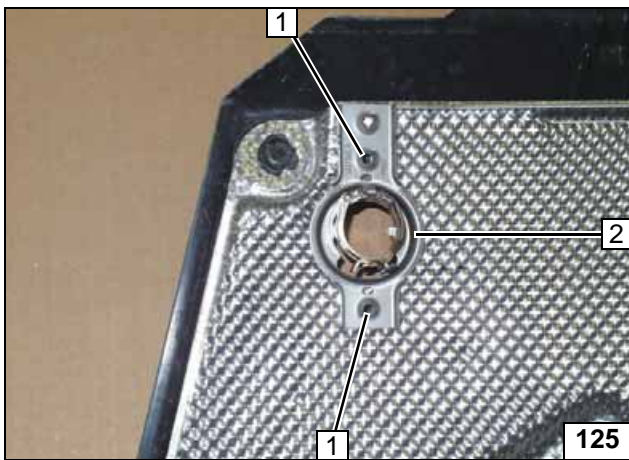

Position exhaust end fastener 2 according to work step 3 of the installation instructions and copy hole pattern 1 [2x]. Hole [2x] according to work step 4 of the installation instructions through engine cover and insulation at position 1.



Holes in underride protection

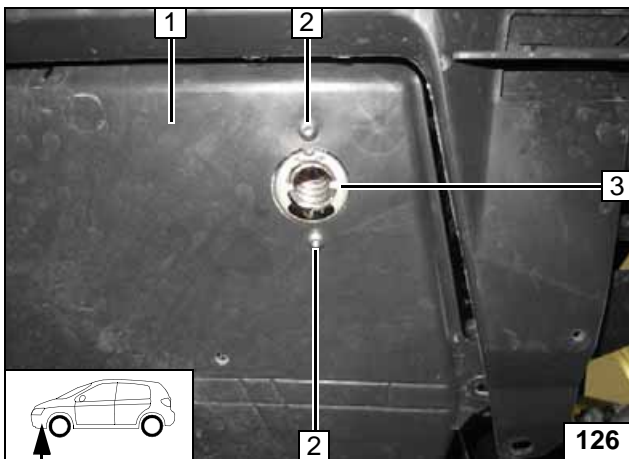

Mount lower engine cover 1.

- 2 Self-tapping screw 5x13 [2x] according to work step 5 of the installation instructions
- 3 Exhaust end fastener



Mounting exhaust end fastener

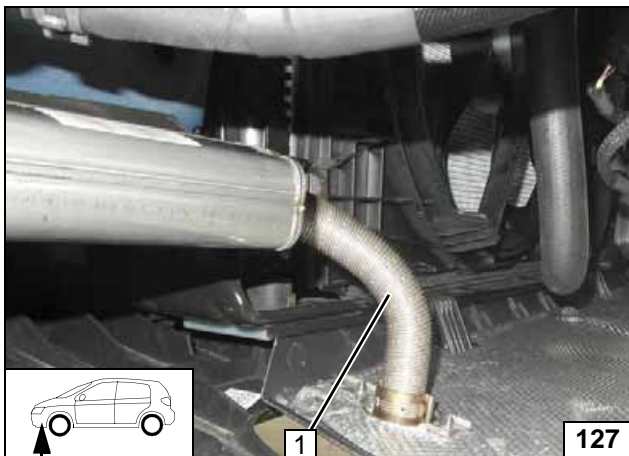

Mount exhaust end section 1 according to work steps 6 - 8 of the installation instructions.



Installing exhaust end section

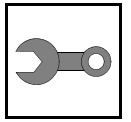

WARNING!

Mount removed parts in reverse order. Check all hoses, clamps and all electrical connections for firm seating. Insulate all loose wires and tie back.

Only use manufacturer-approved coolant. Spray the heater components with anti-corrosion wax (Tectyl 100K, Order No. 111329).



- **Connect the battery.**
- **Fill and bleed the coolant circuit according to the vehicle manufacturer's specifications.**
- **Adjust digital timer, teach telestart transmitter.**
- **Make settings on A/C control panel according to the "Operating Instructions for End Customer".**
- **Place the "Switch off parking heater before refuelling" caution label in the area of the filler neck.**
- **For initial startup and function check, please see installation instructions.**



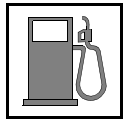

Template for Petrol Fuel Standpipe

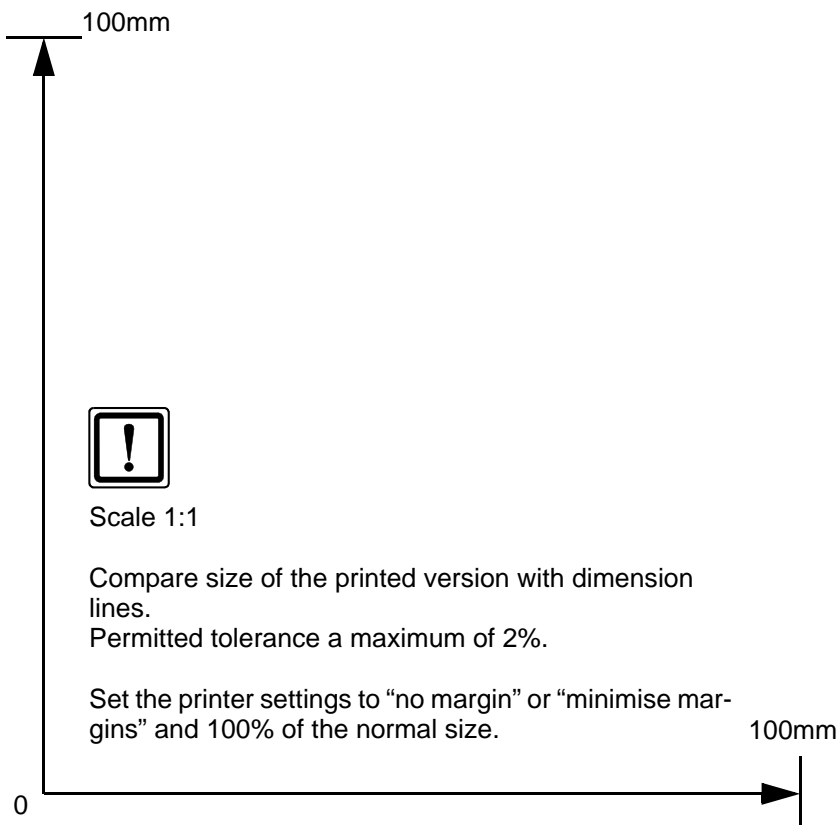
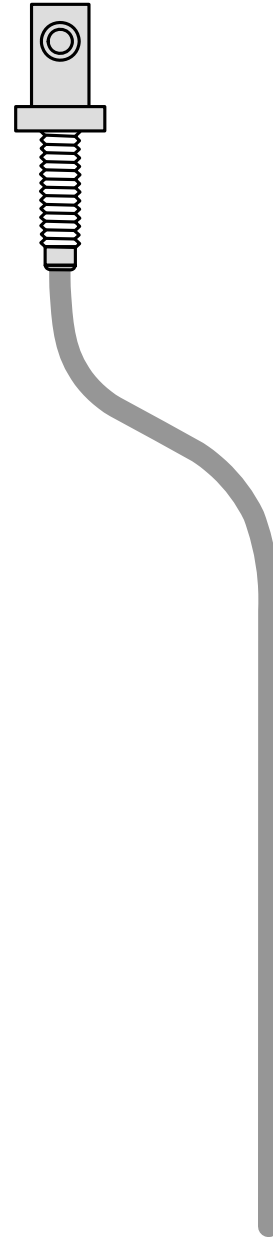

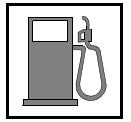

Template for Diesel Fuel Standpipe

Top view

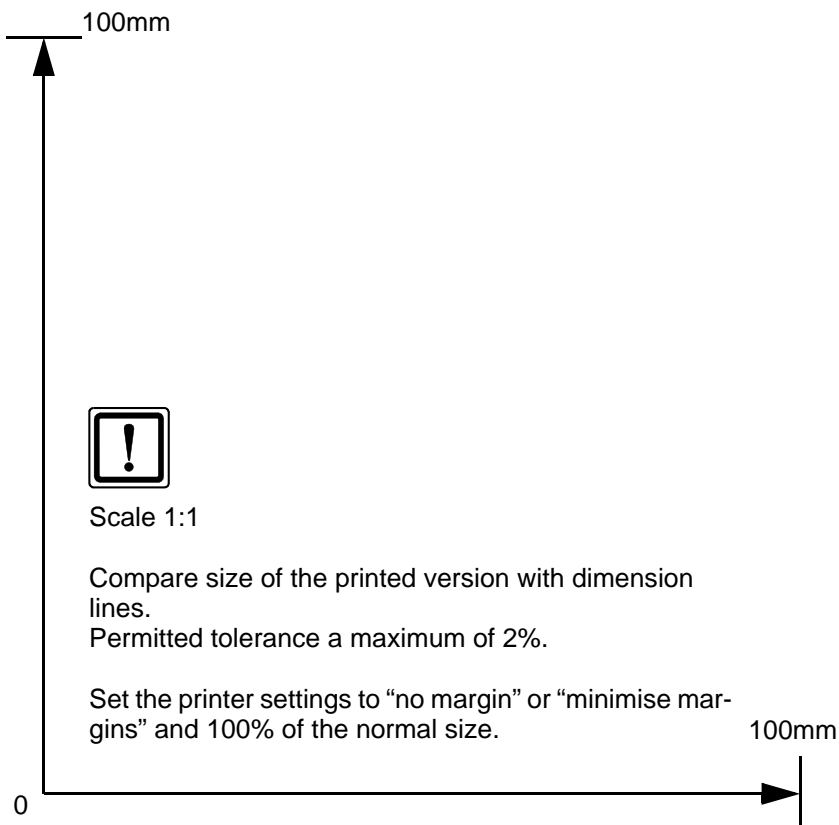
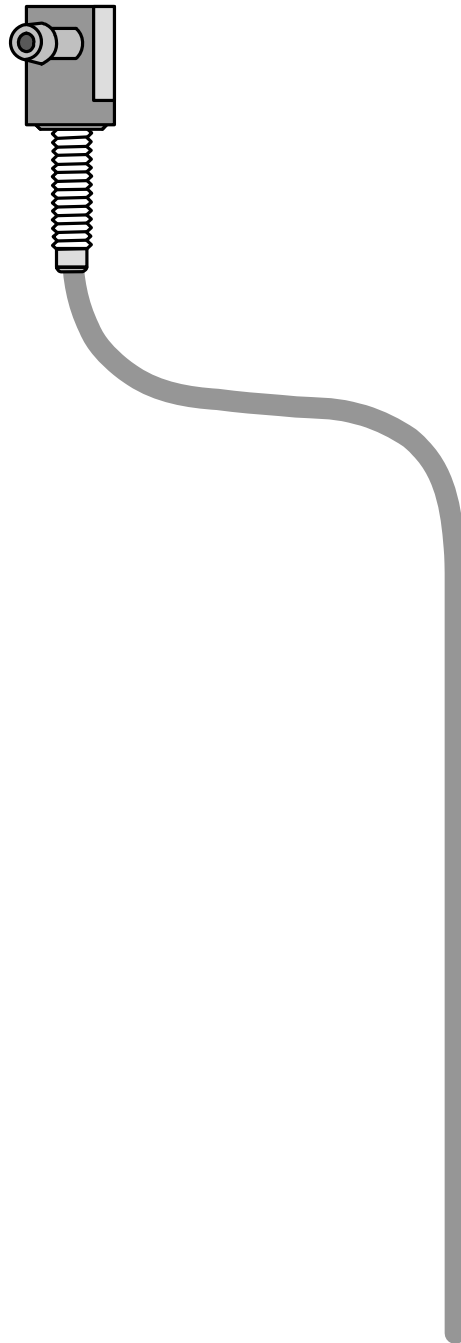
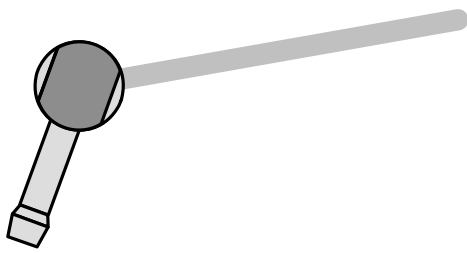

Operating Instructions for End Customer

Please remove page and add to the vehicle operating instructions.

Note:

We recommend matching the heating time to the driving time.
 Heating time = driving time

Example:

For a driving time of approx. 20 min. (in one direction), we recommend not exceeding a switch-on time of 20 min.

Passenger compartment monitoring, if installed, must be deactivated in addition to the vehicle settings for the heating operation.

For instructions on deactivation, please refer to the operating instructions of the vehicle.

No further settings need to be made before parking the vehicle:

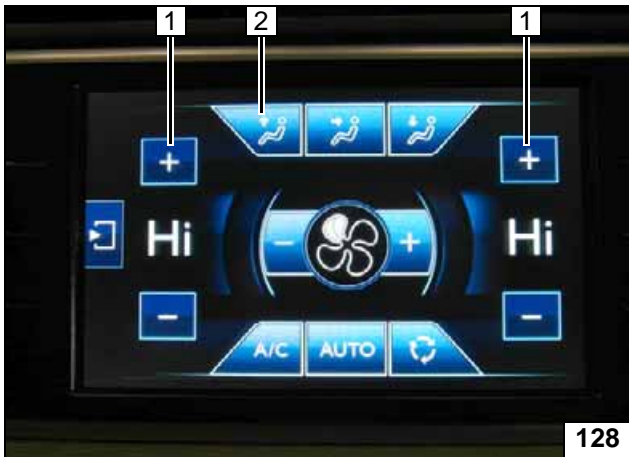

- 1 Set temperature on both sides to "HI"
- 2 Air outlet faces "upward"

A/C control panel

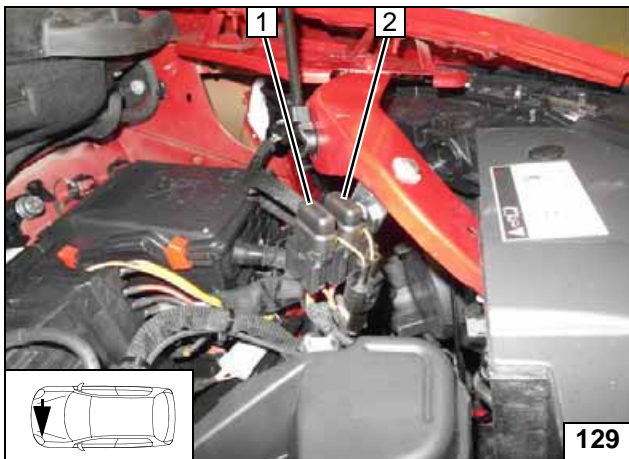

- 1 20A heater fuse F1
- 2 30A fuse of passenger compartment F2

Fuses of engine compartment

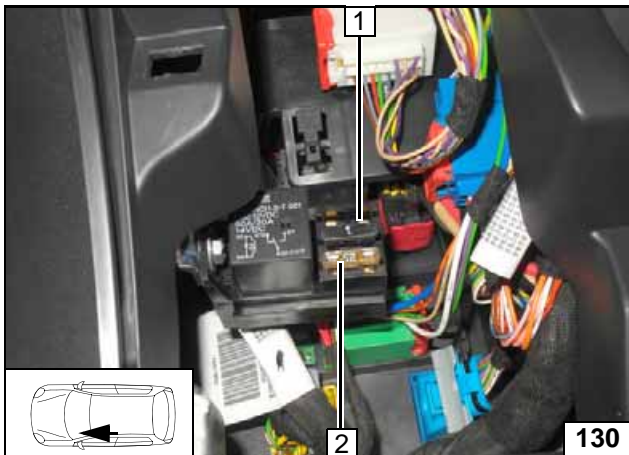

- 1 1A fuse of heater control F3
- 2 25A fan fuse F4

Fuses of passenger compartment

