

Water Heater

Thermo Top Evo Parking Heater



Installation Documentation Chevrolet Trax

Validity

Manufacturer	Model	Type	EG-BE No. / ABE
Chevrolet	Trax	KL1B	e4 * 2007 / 46 * 0696 * ...

Motorisation	Fuel	Transmission type	Output in kW	Displacement in cm ³	Engine code
1.7 D	Diesel	6-gear SG	96	1686	A17DTS (LUD)
1.7 D	Diesel	AG	96	1686	A17DTS (LUD)

SG = Manual Transmission
AG = Automatic Transmission

Starting with model year 2013 Left-hand drive vehicle

Verified equipment variants:	Manual air-conditioning Front fog light Daytime running lights Start-Stop 2 WD / 4 WD
Not verified:	Automatic air-conditioning Passenger compartment monitoring
Total installation time:	approx. 7 hours

Chevrolet Trax

Table of Contents

Validity	1	Preparing Installation Location	12
Necessary Components	2	Preparing Heater	13
Installation Overview	2	Installing Heater	15
Notes on Total Installation Time	2	Fuel	16
Notes on Operating and Installation Instructions	3	Combustion Air	19
Notes on Validity	4	Exhaust Gas	20
Technical Instructions	4	Coolant Circuit	22
Explanatory Notes on Document	4	Final Work	30
Preliminary Work	5	Operating Instructions for End Customer	31
Installation Location of Heater	5		
Preparing Electrical System	6		
Electrical System	7		
Fan Controller	8		
Digital Timer	10		
Remote Option (Telestart)	10		
Remote Option (Thermo Call)	11		

Necessary Components

- Basic delivery scope for *Thermo Top Evo* based on price list
- Installation kit for Chevrolet Trax 2013 Diesel: **1321413A**
- Heater control in accordance with price list and upon consultation with end customer
- In case of Telestart, indicator lamp in accordance with price list and in consultation with end customer

Installation instructions:

- Arrange for the vehicle to be delivered with the tank only about $\frac{1}{4}$ full!
- The installation location of the push button in the case of Telestart or Thermo Call should be confirmed with the end customer.
- When installing a parking heater, we recommend the use of a larger battery for the vehicle.

Installation Overview

Legend:

1. Heater
2. Fuse holder of engine compartment
3. Relay and fuse holder of passenger compartment
4. Circulating pump
5. Digital timer
6. Metering pump

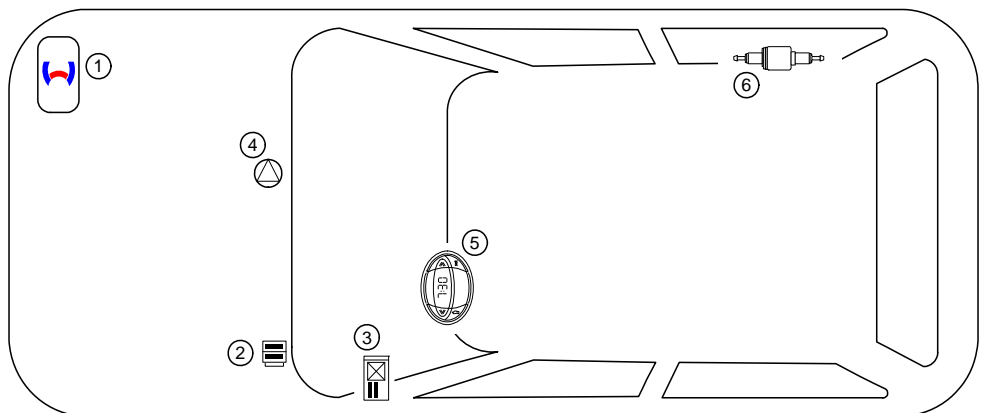

Notes on Total Installation Time

The total installation time includes the time needed for mounting and demounting of the vehicle-specific components, the heater specific installation time and all other times required for the system integration and initial start-up of the heater.

The total installation time may vary for vehicle equipment other than provided.

Notes on Operating and Installation Instructions

1 Important Information (not complete)

1.1 Installation and Repair



The improper installation or repair of Webasto heating and cooling systems can cause fire or the leakage of deadly carbon monoxide, leading to serious injury or death.



To install and repair Webasto heating and cooling systems you need to have completed a special company training course and have the appropriate technical documentation, special tools and special equipment.



Installation and repair may ONLY be carried out by persons trained and certified in a Webasto training course. NEVER try to install or repair Webasto heating or cooling systems if you have not completed a Webasto training course, you do not have the necessary technical skills and you do not have the technical documentation, tools and equipment available to ensure that you can complete the installation and repair work properly.

Only use genuine Webasto parts. See the Webasto air and water heaters accessories catalogue for this purpose.

1.2 Operation

To ensure safe operation, we recommend having the heater checked every two years by an authorised Webasto dealer, especially when used over a long period and/or under extreme environmental conditions.

Do not operate the heater in closed rooms due to the danger of poisoning and suffocation.

Always switch off the heater before refuelling.

The heater may only be used with the prescribed fuel Diesel (DIN EN 590) or petrol (DIN EN 227).

The heater may not be cleaned with a high-pressure cleaner.

1.3 Please note

ALWAYS follow all Webasto installation and operating instructions and observe all warnings.

To become familiar with and understand all functions and properties of the heater, the operating instructions must be read carefully and observed at all times.

For proper, safe installation and repair work, the installation instructions with all warnings and safety information must be carefully read and observed at all times. Please always contact a workshop authorised by Webasto for all installation and repair work.

Important

Webasto shall assume no liability for defects, damage and injuries resulting from a failure to observe the installation, repair and operating instructions of the information contained in them.

This liability exclusion particularly applies to improper installations and repairs, installations and repairs by untrained persons or in the case of a failure to use genuine spare parts.

The liability due to culpable disregard to life, limb or health and due to damage or injuries caused by a wilful or reckless breach of duty remain unaffected, as does the obligatory product liability.

Installation should be carried out according to the general, standard rules of technology. Unless specified otherwise, fasten hoses, lines and wiring harnesses to original vehicle lines and wiring harnesses using cable ties. Insulate loose wires and tie back. Connectors of electronic components have to audibly snap into place when inserting them during installation.

Sharp edges should be fitted with rub protection. Spray unfinished body areas, e.g. drilled holes, with anti-corrosion wax (Tectyl 100K, Order No. 111329).

Observe the instructions and guidelines of the respective vehicle manufacturer for demounting and mounting vehicle specific components!

The initial startup is to be executed with the Webasto Thermo Test Diagnosis.

When installing an IPCU, the corresponding settings must be checked or adjusted before the installation.

2 Statutory regulations governing installation

Guidelines	Thermo Top Evo
Heating Directive ECE R122	E1 00 0258
EMC Directive ECE R10	E1 04 5627

Note

The regulations of these guidelines are binding in the scope of the Directive 70/156/EEC and/or 2007/46/EC (for new vehicle models from 29/04/2009) and should also be observed in countries in which there are no special regulations.

Important

Failure to follow the installation instructions will result in the invalidation of the type approval for the heater and therefore invalidation of the general **homologation of the vehicle**.

Note

For vehicles with an EU permit, no entry in accordance with § 19 Sub-Section 4 of Annex VIII b to the Road Traffic Act is required.

2.1 Excerpt from the directive 2001/56/EC Appendix VII for the installation of the heater

Beginning of excerpt.

ANNEX VII

REQUIREMENTS FOR COMBUSTION HEATERS AND THEIR INSTALLATION

1. GENERAL REQUIREMENTS

1.7.1. A clearly visible operation indicator in the operator's field of view shall inform when the combustion heater is switched on or off.

2. VEHICLE INSTALLATION REQUIREMENTS

2.1. Scope

2.1.1. Subject to paragraph 2.1.2. combustion heaters shall be installed according to the requirements of this Annex.

2.1.2. Vehicles of category O having liquid fuel heaters are deemed to comply with the requirements of this Annex.

2.2. Positioning of the heater

2.2.1. Body sections and any other components in the vicinity of the heater must be protected from excessive heat and the possibility of fuel or oil contamination.

2.2.2. The combustion heater shall not constitute a risk of fire, even in the case of overheating. This requirement shall be deemed to be fulfilled if the installation ensures an adequate distance to all parts and suitable ventilation, by the use of fire resistant materials or by the use of heat shields.

2.2.3. In the case of M2 and M3 vehicles, the heater must not be positioned in the passenger compartment. However, an installation in an effectively sealed envelope which also complies with the conditions in paragraph 2.2.2 may be used.

2.2.4. The label referred to in paragraph 1.4 or a duplicate, must be positioned so that it can be easily read when the heater is installed in the vehicle.

2.2.5. Every reasonable precaution should be taken in positioning the heater to minimise the risk of injury and damage to personal property.

2.3. Fuel supply

2.3.1. The fuel filler must not be situated in the passenger compartment and must be provided with an effective cap to prevent fuel spillage

2.3.2. In the case of liquid fuel heaters, where a supply separate to that of the vehicle is provided, the type of fuel and its filler point must be clearly labelled

2.3.3. A notice, indicating that the heater must be shut down before refuelling, must be affixed to the fuelling point. In addition a suitable instruction must be included in the manufacturer's operating manual.

2.4. Exhaust system

2.4.1. The exhaust outlet must be located so as to prevent emissions from entering the vehicle through ventilators, heated air inlets or opening windows.

2.5. Combustion air inlet

2.5.1. The air for the combustion chamber of the heater must not be drawn from the passenger compartment of the vehicle.

2.5.2. The air inlet must be so positioned or guarded that blocking by rubbish or luggage is unlikely.

2.6. Heating air inlet

2.6.1. The heating air supply may be fresh or recirculated air and must be drawn from a clean area not likely to be contaminated by exhaust fumes emitted either by the propulsion engine, the combustion heater or any other vehicle source.

2.6.2. The inlet duct must be protected by mesh or other suitable means.

2.7. Heating air outlet

2.7.1. Any ducting used to route the hot air through the vehicle must be so positioned or protected that no injury or damage could be caused if it were to be touched.

2.7.2. The air outlet must be so positioned or guarded that blocking by rubbish or luggage is unlikely.

End of excerpt.

In multilingual versions the German language is binding.

Chevrolet Trax

Notes on Validity

This installation documentation applies to the vehicles Chevrolet Trax Diesel - see page 1 for validity - starting with model year 2013 and later, if technical changes to the vehicle do not influence the installation, excluding any liability claims. Depending on the vehicle version and equipment, modifications may be necessary during installation with respect to these "installation instructions".

Vehicle and motor types, equipment variants and other specifications that were not listed in this installation documentation have not been tested. However, installation according to this installation documentation may be possible.

Technical Instructions

Special tools

- Hose clamp pliers for self-clamping hose clamps
- Hose clamp pliers for Clic hose clamps of type W
- Automatic wire stripper 0.2 - 6mm²
- Crimping pliers for cable lug / tab connector 0.5 - 6mm²
- Torque wrench for 2.0 - 10 Nm
- Hose clamping pliers
- Metric thread-setter kit
- Webasto Thermo Test Diagnosis with current software

Dimensions

- All dimensions are in mm.

Tightening torque values

- Tightening torque values of 5x13 heater bolts and 5x11 heater stud bolts = 8Nm.
- Tightening torque value of 5x15 bolt of water connection piece retaining plate = 7Nm!
- Tighten other bolt connections in accordance with manufacturer's instructions or in accordance with state-of-the-art-technology.

Explanatory Notes on Document

You will find an identification mark on the outside top right corner of the page in question to provide you with a quick overview of the individual working steps.

Special features are highlighted using the following symbols:

Mechanical system



Electrical system



Coolant circuit

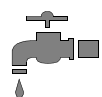

Combustion air

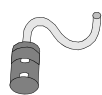

Fuel



Exhaust gas



Software



Specific risk of injury or fatal accidents



Specific risk of damage to components



Specific risk of fire or explosion.



Reference to general installation instructions of the Webasto components or to the manufacturer's vehicle-specific documents.



Reference to a special technical feature.



The arrow in the vehicle icon indicates the position on the vehicle and the viewing angle

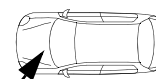
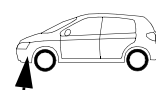

Chevrolet Trax

Preliminary Work

Vehicle

- Open the fuel tank cap.
- Ventilate the fuel tank.
- Close the fuel tank cap again.
- Depressurise the cooling system.
- Disconnect and remove the battery.
- Disconnect the air filter housing together with the plenum.
- Detach the coolant expansion tank.
- Remove the right front wheel.
- Remove the front wheel well trim on the right hand side.
- Remove the upper trim in the footwell on the front passenger's side.
- Remove the lower instrument panel trim on the driver's side.
- Remove the lateral instrument panel trim on the driver's side.

Heater

- Remove years that do not apply from the type and duplicate label.
- Attach the duplicate label (type label) in the appropriate place in the engine compartment.

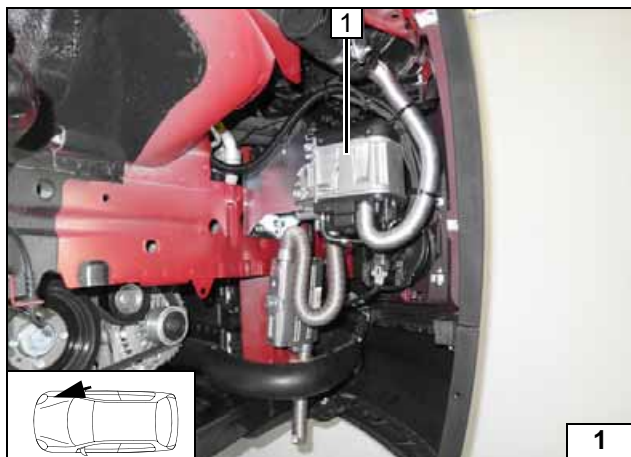

Installation Location of Heater

1 Heater

Installation
location

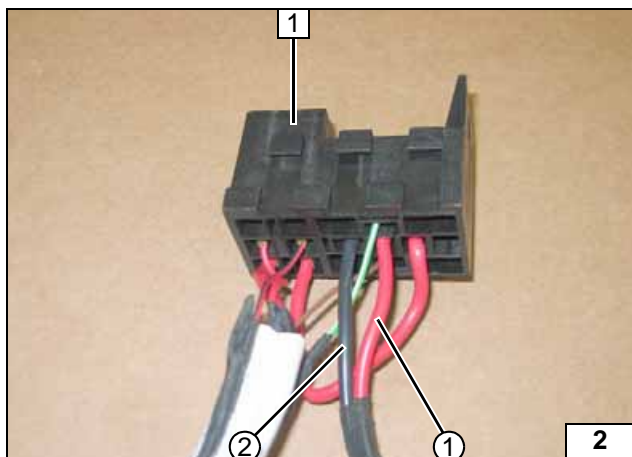

Preparing Electrical System

Wire sections retain their numbering throughout the entire document.

- 1 Relay and fuse holder of passenger compartment
- ① Red (rt) wire from K1/87a
- ② Black (sw) wire of K1/30

Preparing relay and fuse holder of passenger compartment

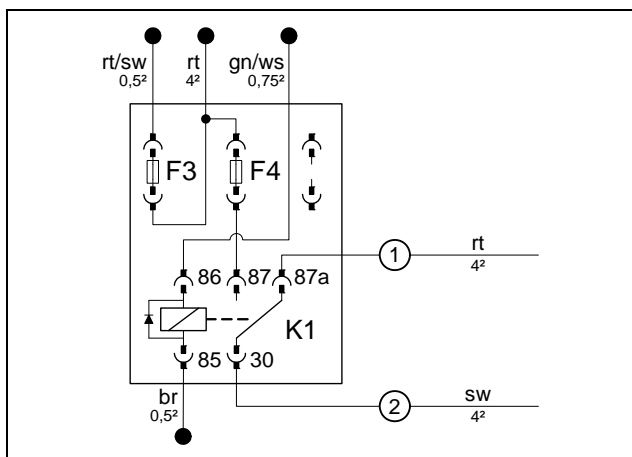

Connect wires according to the wiring diagram. K1 relay and 25A fuse F4 will only be inserted after installing the relay and fuse holder.

Preparing relay and fuse holder of passenger compartment

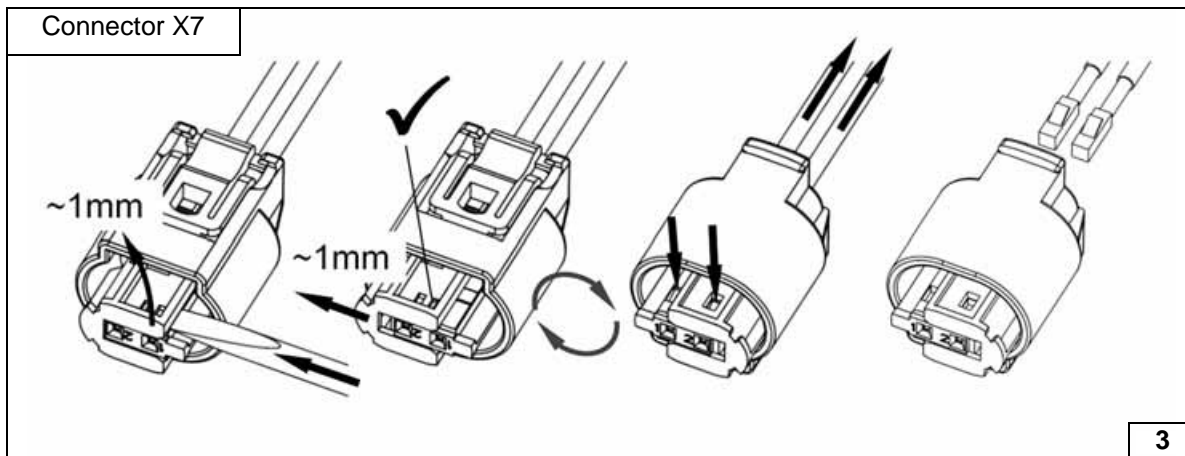

Dismantling connector of metering pump



Electrical System

Earth wire

- 1 Earth wire on negative terminal of battery

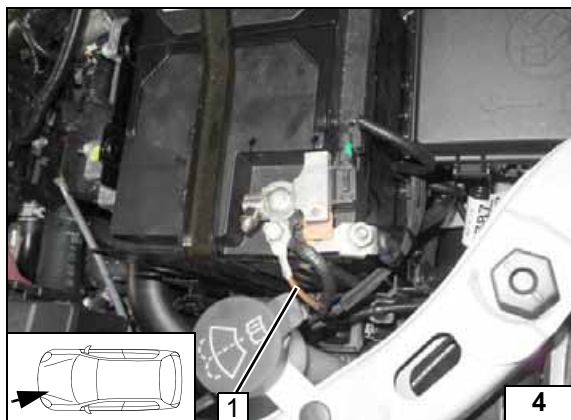

Positive wire

- 1 Positive wire on positive terminal of battery

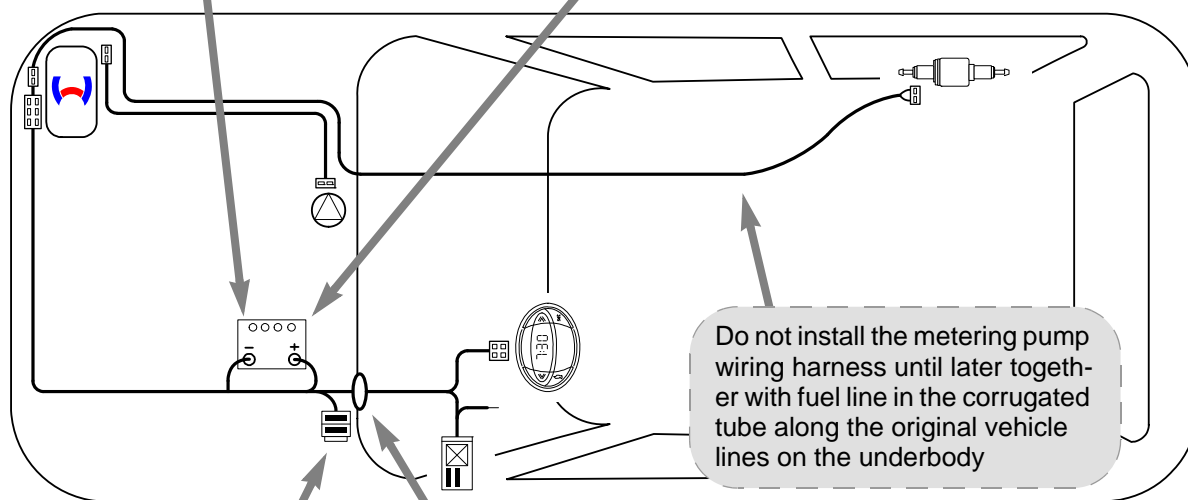
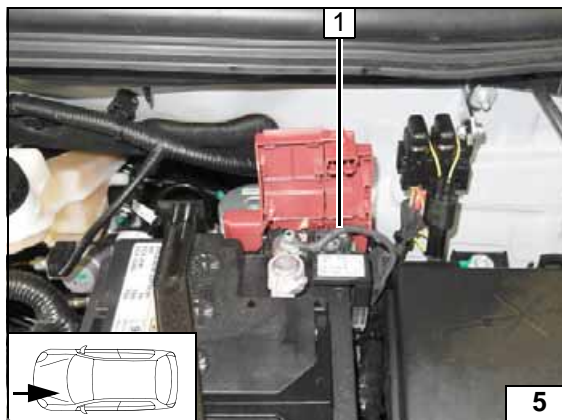

Wiring harness routing diagram

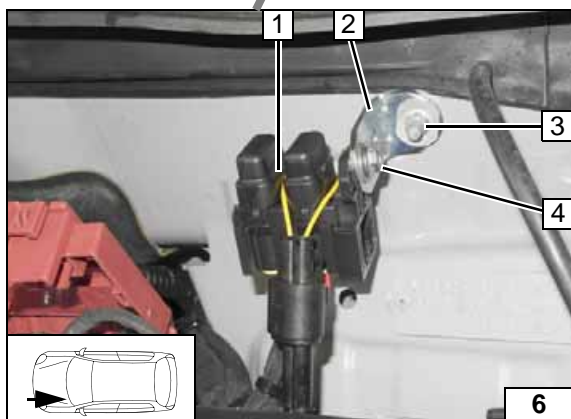

Fuse holder of engine compartment

- 1 Fuses F1-2
- 2 Angle bracket
- 3 Original vehicle stud bolt, plate nut
- 4 M5x16 bolt, large diameter washer [2x], retaining plate of fuse holder, nut

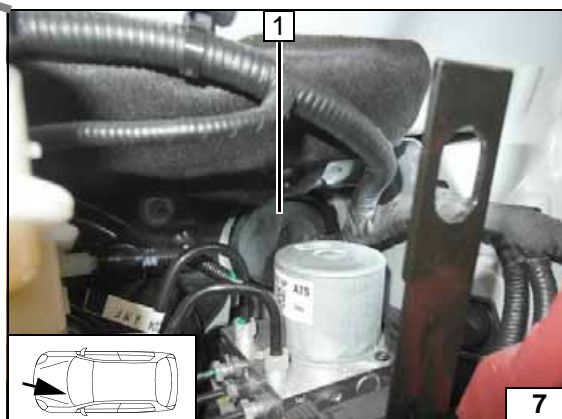

Wiring harness pass through

- 1 Protective rubber plug

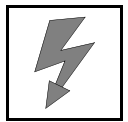

Fan Controller

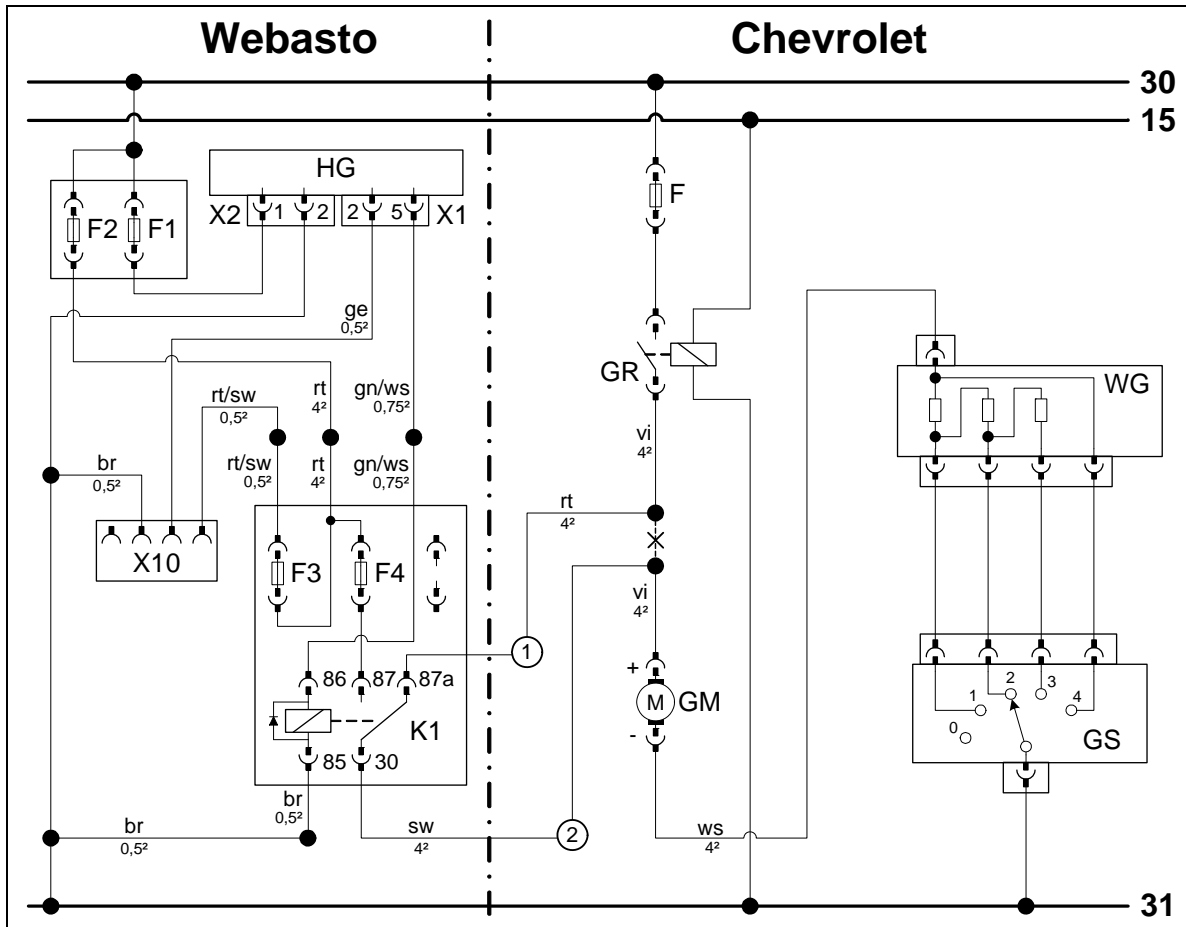

Wiring diagram

Webasto components		Vehicle components		Colours and symbols	
HG	Heater TT-Evo	F	Fuse	rt	red
X1	6-pin heater connector	GR	Fan relay	sw	black
X2	2-pin heater connector	WG	Resistor group	ge	yellow
F1	20A fuse	GM	Fan motor	gn	green
F2	30A fuse	GS	Fan switch	vi	violet
X10	4-pin connector of heater control			ws	white
F3	1A fuse			br	brown
F4	25A fuse			X	Cutting point
K1	Fan relay			Wiring colours may vary.	

Legend

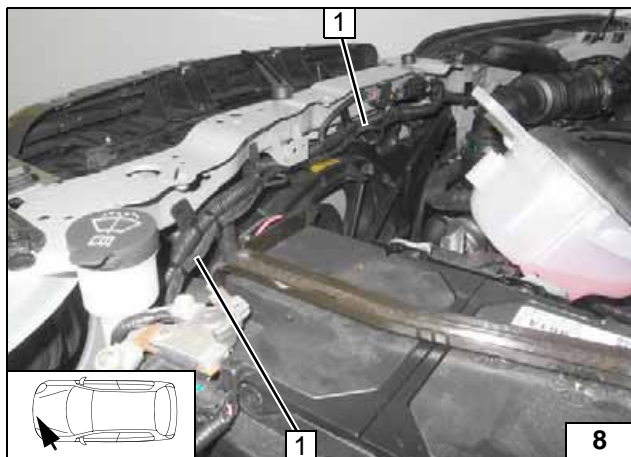

Route wiring harness of heater 1 along original vehicle wiring harness to installation location of heater.



Routing of heater wiring harness

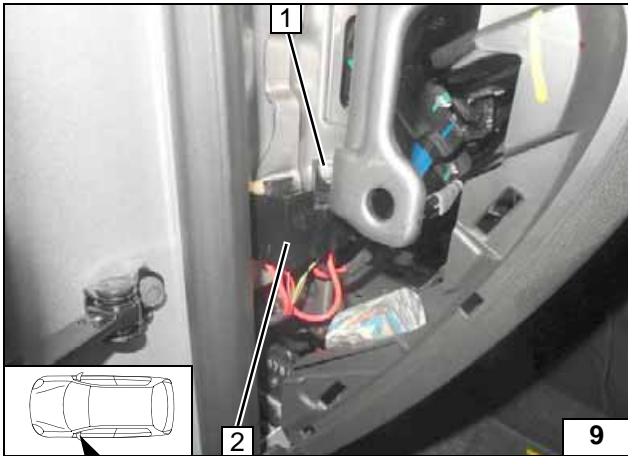
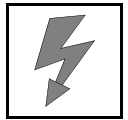

- 1 M5x16 bolt, large diameter washer [2x], nut, existing hole
- 2 Relay and fuse holder of passenger compartment

Mounting relay and fuse holder of passenger compartment

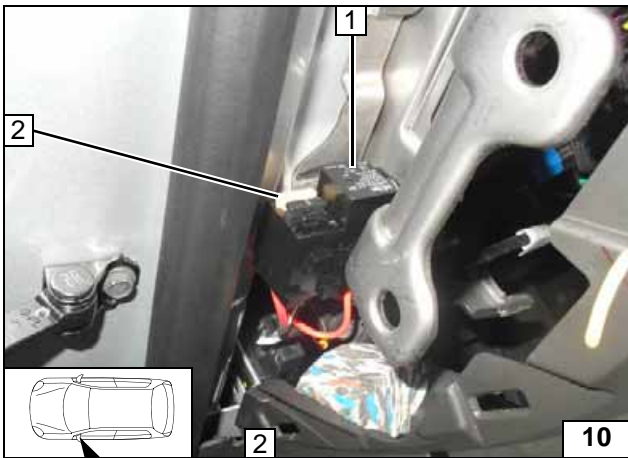

- 1 K1-relay
- 2 25A fuse F4

Inserting K1 relay and F4 fuse

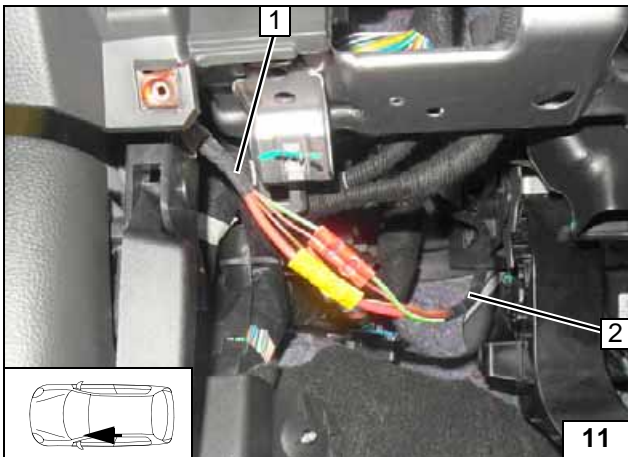

- 1 Wiring harness of passenger compartment relay and fuse holder
- 2 Wiring harness of heater

Connecting wiring harnesses using same colour wires

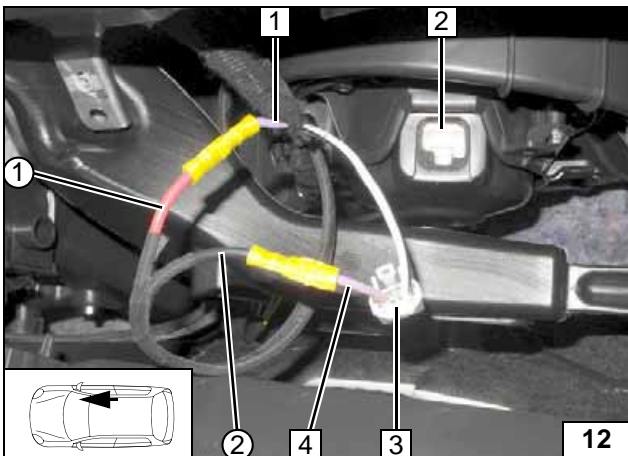

Connection to 2-pin connector **3** from the fan motor. Produce connections as shown in wiring diagram.

- 1 Violet (ws) wire of fan relay
- 2 Socket of connector GM
- 4 Violet (vi) wire of connector GM
- ① Red (rt) wire from K1/87a
- ② Black (sw) wire of K1/30



Connecting fan motor

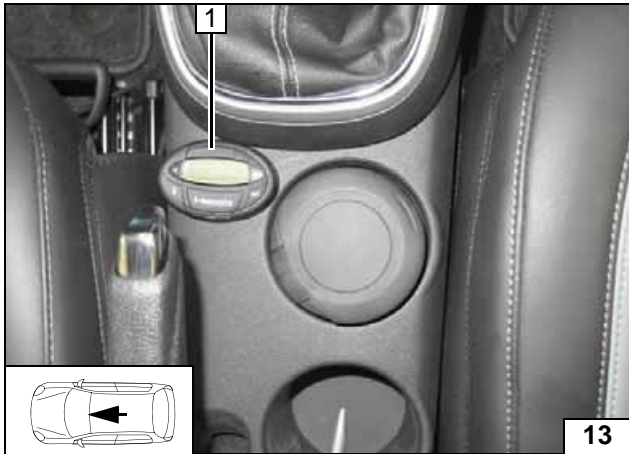

Digital Timer

- 1 Digital timer



Installing digital timer

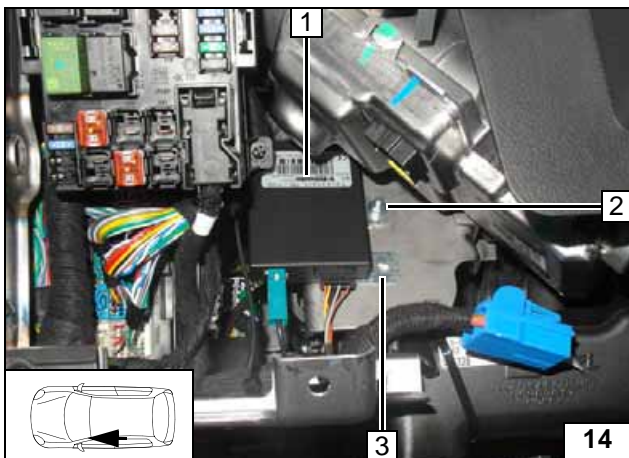

Remote Option (Telestart)

- 1 Receiver
- 2 M5x16 bolt, flanged nut, existing hole
- 3 Bracket



Installing receiver

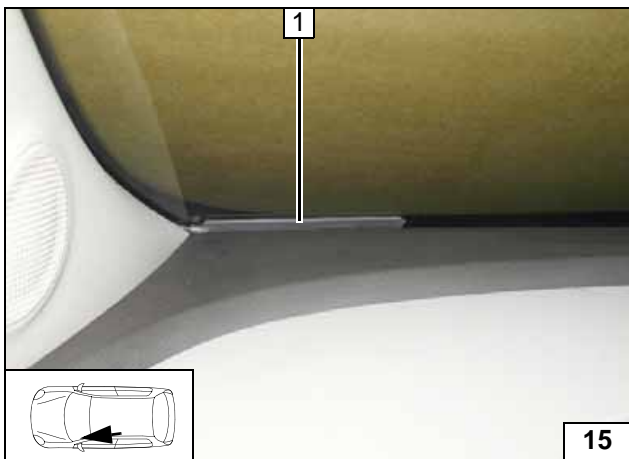

- 1 Antenna

Installing antenna

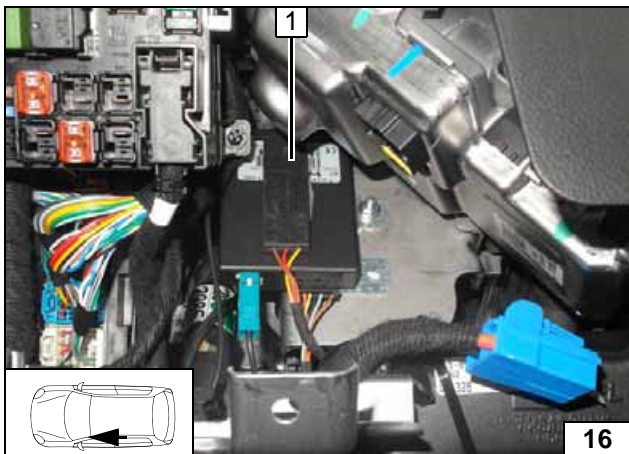

Temperature sensor T100 HTM

Fasten temperature sensor 1 with adhesive tape.



Installing temperature sensor

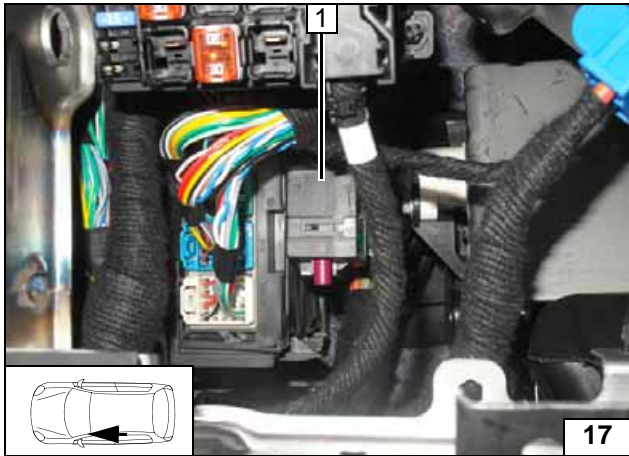
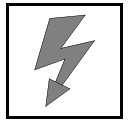

Remote Option (Thermo Call)

Fasten receiver 1 with adhesive tape.

Installing receiver

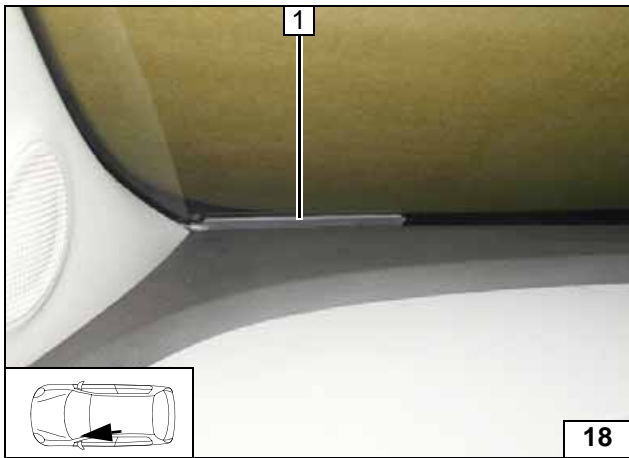

1 Antenna

Installing antenna

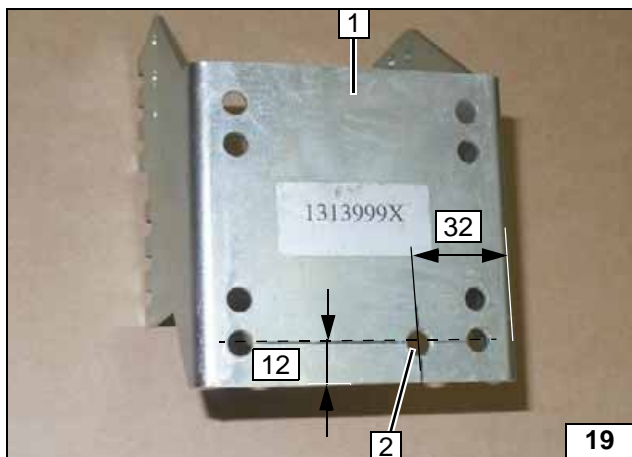

Preparing Installation Location

- 1 Bracket
- 2 7 mm dia. hole

Hole in bracket

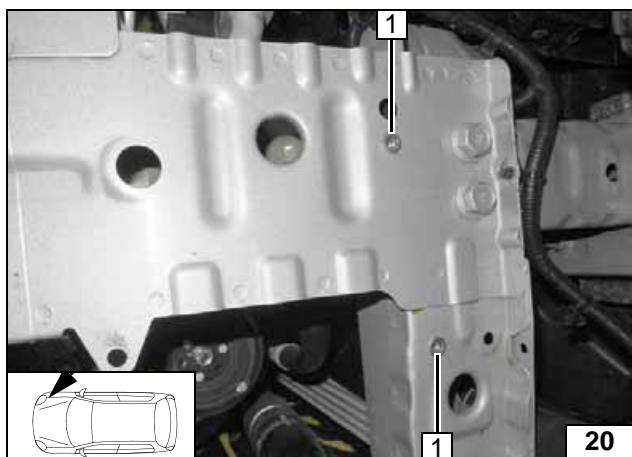

- 1 Drill out hole to 9.1mm dia.; rivet nut [2x]

Installing rivet nuts

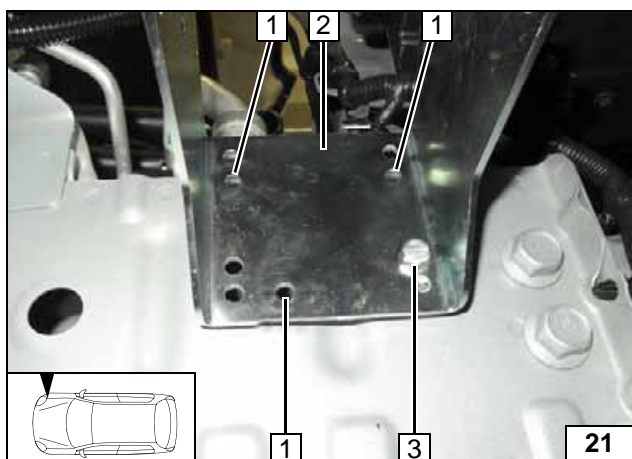

Install bracket 2 loosely and align perpendicularly.

- 1 Copy hole pattern [3x]
- 3 M6x25 bolt



Installing bracket

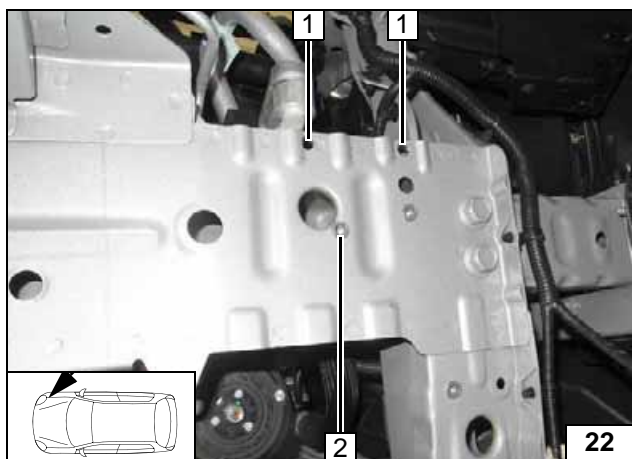

Remove bracket.

- 1 7mm dia. holes [2x]
- 2 9.1mm dia. holes; rivet nut



Installing rivet nut

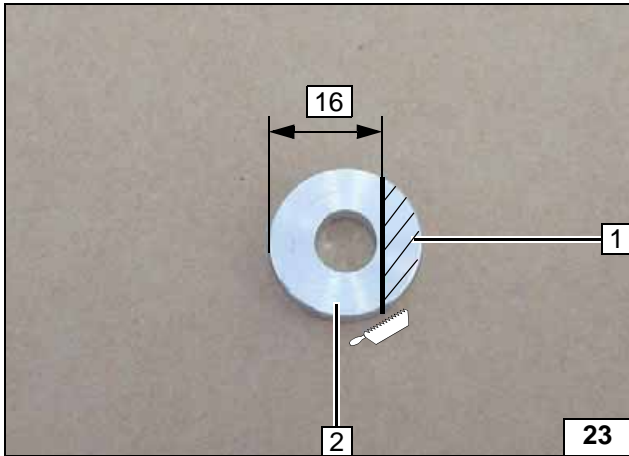

- 1 Discard section.
- 2 5 mm shim

Preparing shim

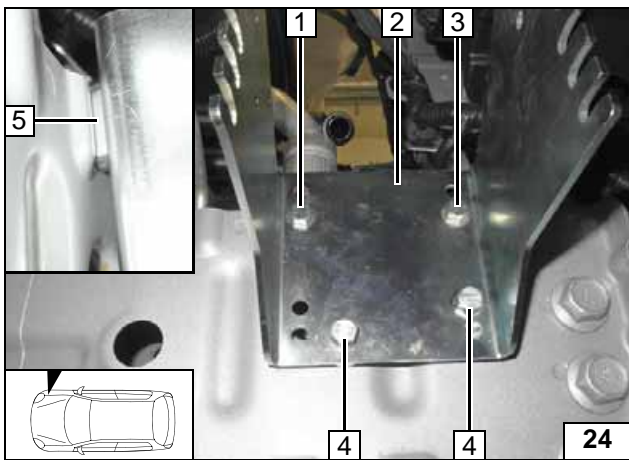

Small figure shows prepared 5mm shim with incision at position 1

- 1 M6x20 bolt, prepared 5mm shim, flanged nut
- 2 Bracket
- 3 M6x20 bolt, spring lockwasher, 5mm shim, flanged nut
- 4 M6x25 bolt, spring lockwasher, 5mm shim, [2x each]

Installing bracket

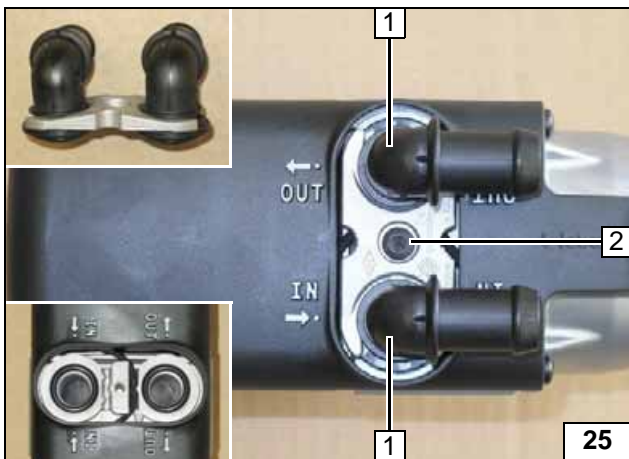

Preparing Heater

- 1 Water connection piece, sealing ring [2x each]
- 2 5x15 self-tapping bolt, retaining plate of water connection piece

Installing water connection pieces

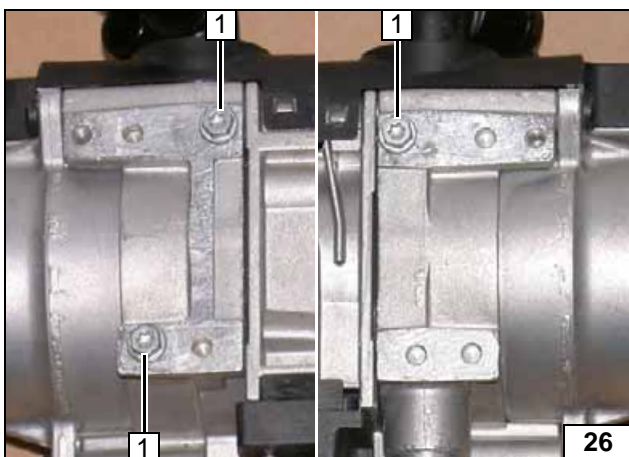

Screw 5x13 self-tapping bolts 1 [3x] into existing holes by a maximum of 3 threads.

Premounting bolts loosely

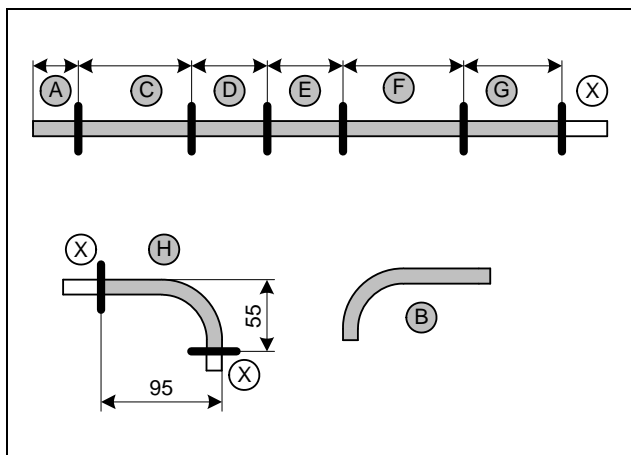
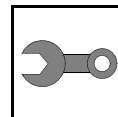

Discard sections **X**.
 Hose **B** = 18mm dia., 90° moulded hose
 Hose **H** = 90°, 20mm dia. moulded hose, cut to length

- A** = 90
- C** = 570
- D** = 190
- E** = 225
- F** = 460
- G** = 360



Cutting hoses to length

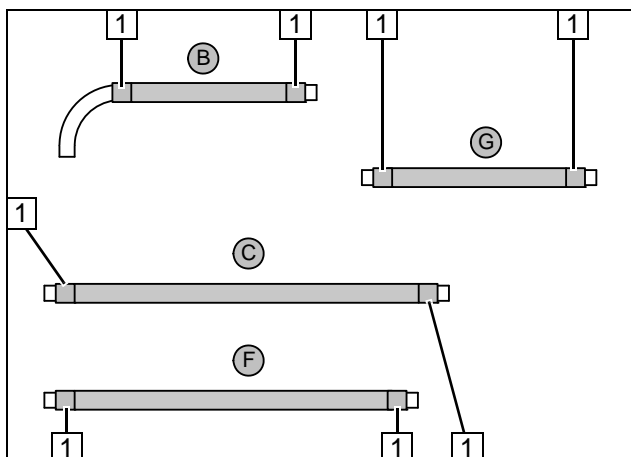

Push braided protection hoses onto hoses **B**, **C**, **F** and **G** and cut to length. Cut heat shrink plastic tubing to length.

- 1** 30 mm long heat shrink plastic tubing [8x]



Preparing hoses

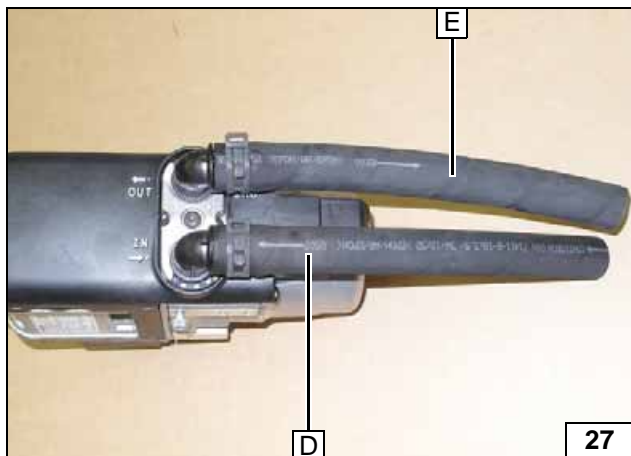

Premounting hoses

- 1** 90° moulded hose, 10mm dia. clamp

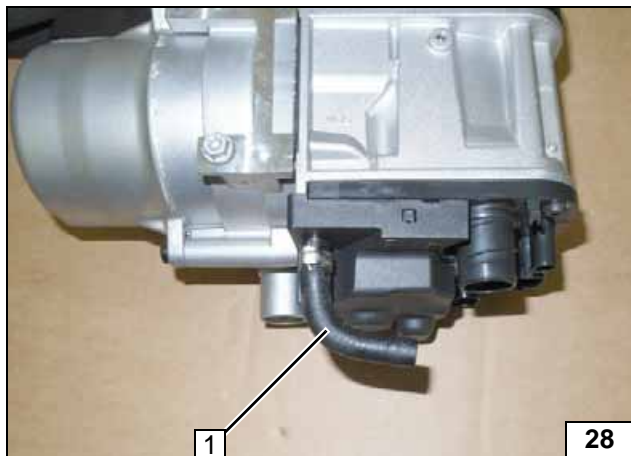

Premounting moulded hose

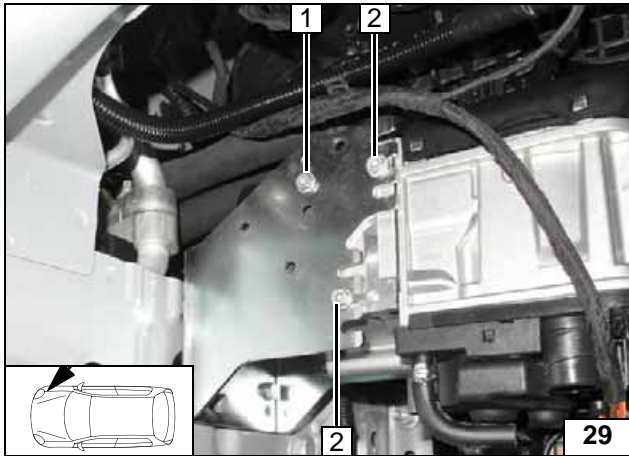
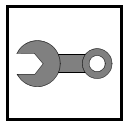

Installing Heater

- 1 5x13 self-tapping bolt
- 2 Tighten 5x13 self-tapping bolt [2x]

Installing heater

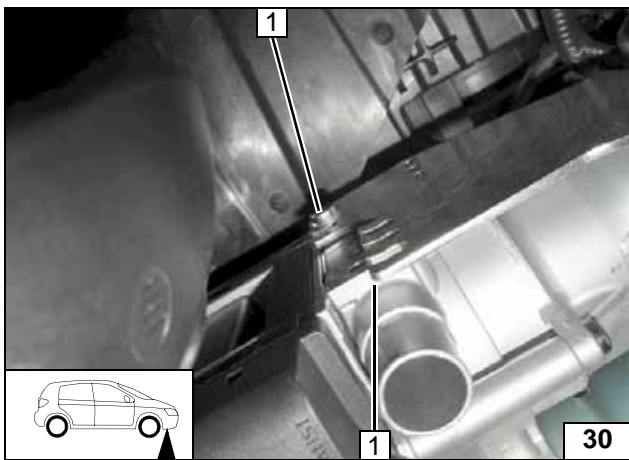

- 1 Tighten 5x13 self-tapping bolt

Installing heater

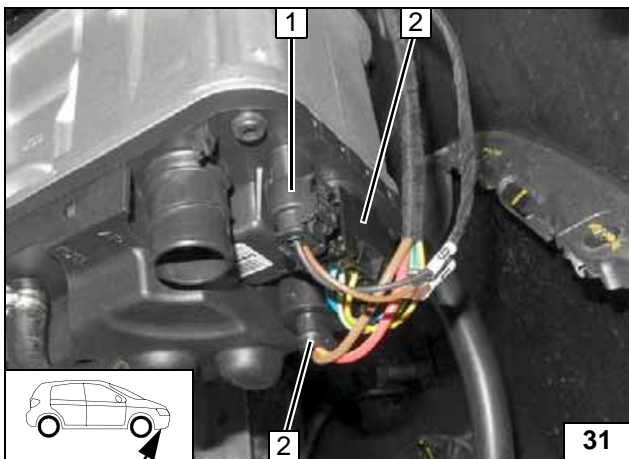

- 1 Connector of circulating pump wiring harness
- 2 Heater wiring harness connector [2x]

Installing wiring harness

Chevrolet Trax

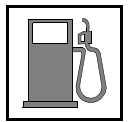

Fuel

CAUTION!

Open the vehicle's fuel tank cap, ventilate the tank and then re-close the tank lock.

Catch any fuel running off in an appropriate container.

Install fuel line and metering pump wiring harness so that they are protected against stone impact. Unless specified otherwise, always fasten using cable ties.

Mount the fuel line and wiring harness with rub protection on sharp edges.

WARNING!

The fuel line and wiring harness are routed to the metering pump as shown in the wiring harness routing diagram.

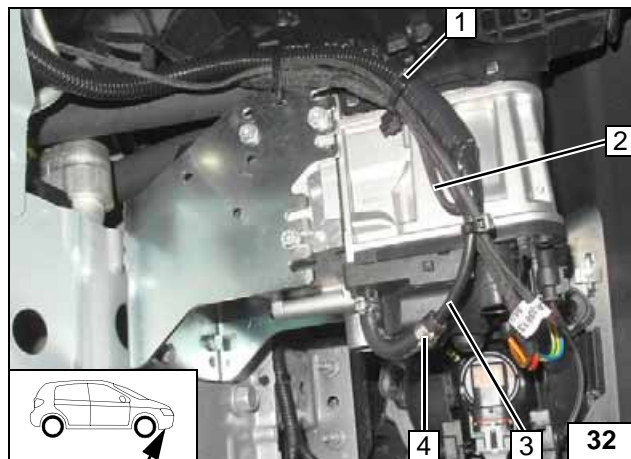

Pull fuel line **3** and wiring harness of metering pump **2** into 10mm dia., 2100mm long corrugated tube **1** and route in engine compartment.

4 10mm dia. clamp

Connecting heater

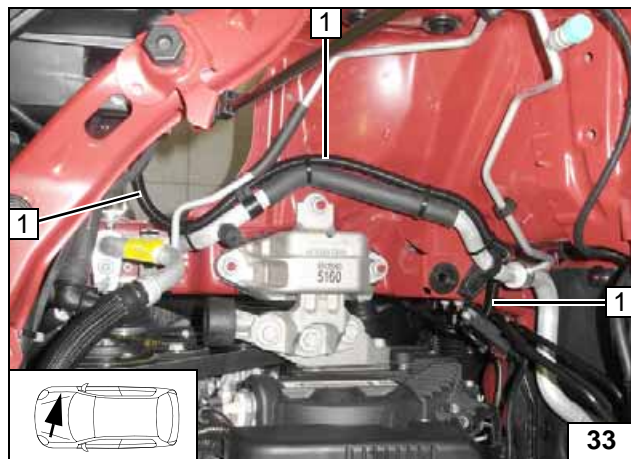

Route fuel line and wiring harness of metering pump in corrugated tube **1** along original vehicle lines to underbody.

Installing lines

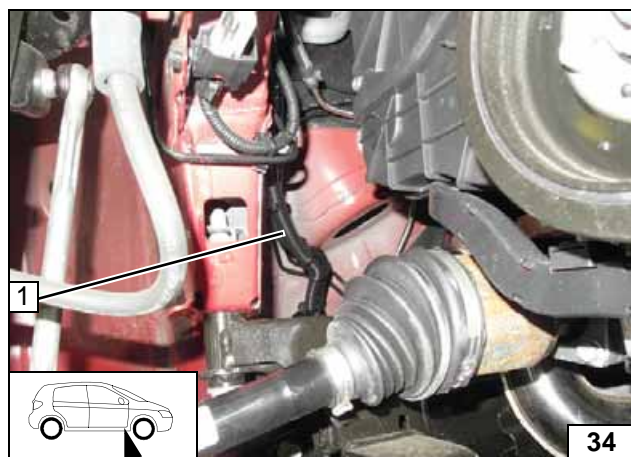

1 Fuel line and wiring harness of metering pump in corrugated tube

Installing lines

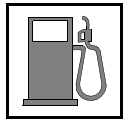

Installing lines



Premounting metering pump



Installing metering pump



Fuel extraction

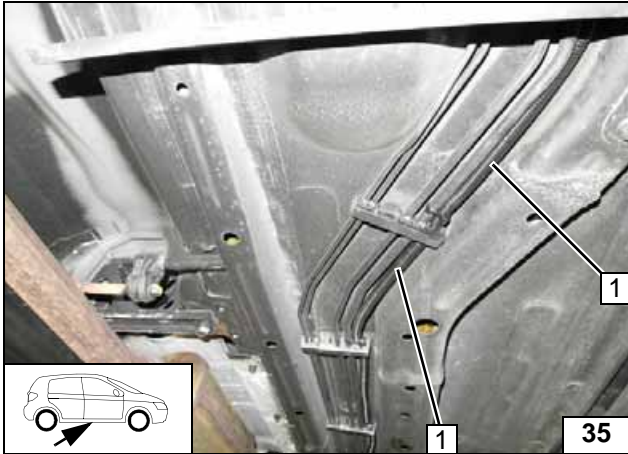

Route fuel line and wiring harness of metering pump in corrugated tube 1 along original vehicle lines to installation location of metering pump.

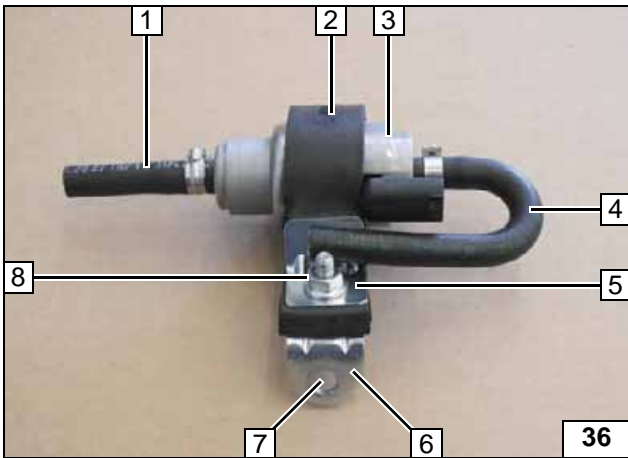

Drill out angle bracket 6 at position 7 to 8.5mm dia.

- 1 Hose section, 10 mm dia. clamp
- 2 Mounting of metering pump
- 3 Metering pump
- 4 180° moulded hose, 10mm dia. clamp
- 5 Support angle bracket
- 8 M6x25 bolt, flanged nut

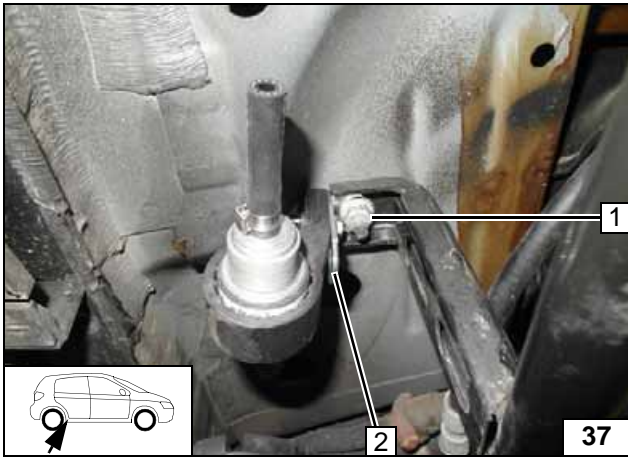

- 1 Original vehicle stud bolt, original vehicle nut
- 2 Angle bracket

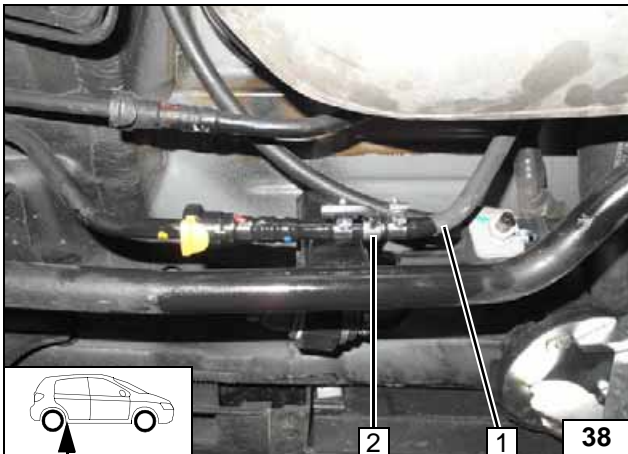

Separate fuel return line 1 at Position 2.

- 2 90°, 8x5x8 fuel standpipe, 10 mm dia. hose clamp [2x] in fuel return line

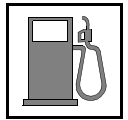

Connect-
ing meter-
ing pump

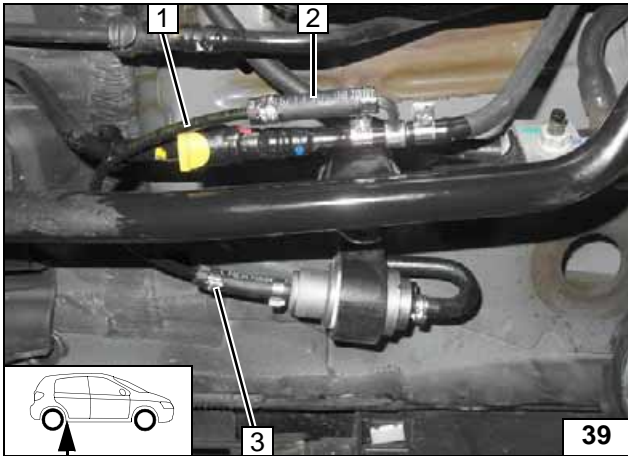

- 1 Fuel line of fuel standpipe
- 2 Hose section, 10mm dia.clamp [2x]
- 3 10mm dia. clamp

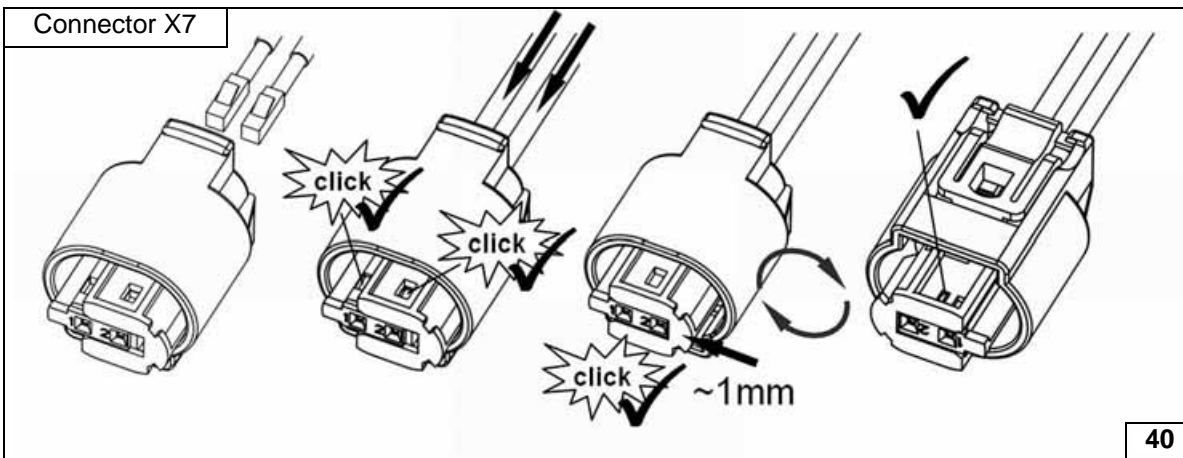

Dismant-
ling con-
nector of
metering
pump

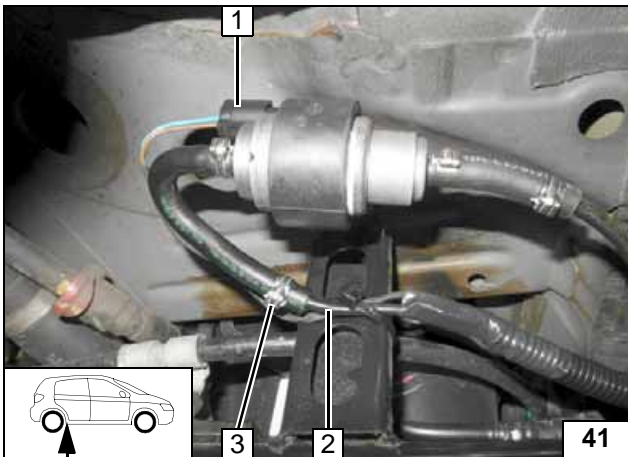

Ensure sufficient distance to adjacent components, ensure freedom of movement, correct if necessary.

- 1 Wiring harness of metering pump, con-
nector mounted
- 2 Fuel line of heater
- 3 10mm dia. clamp



Connect-
ing meter-
ing pump

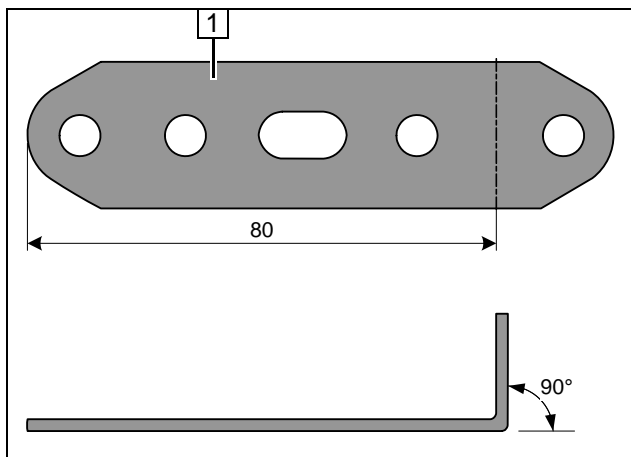
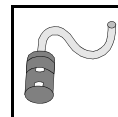

Combustion Air

- 1 Perforated bracket

Preparing perforated bracket

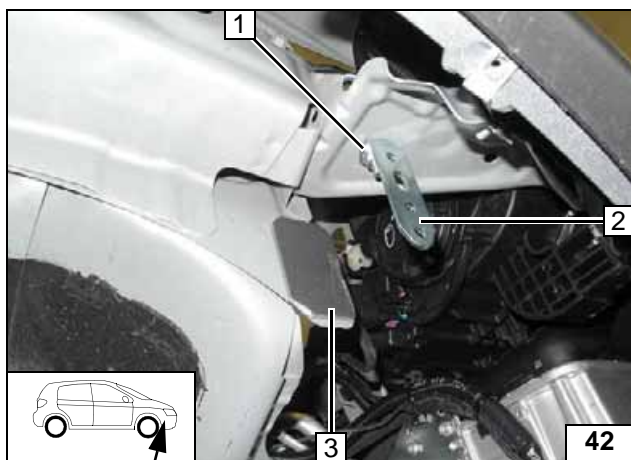

- 1 M6x20 bolt, flanged nut, existing hole
- 2 Perforated bracket
- 3 Paste insulation protection strips

Installing perforated bracket



- 1 Combustion air pipe

Installing combustion air pipe

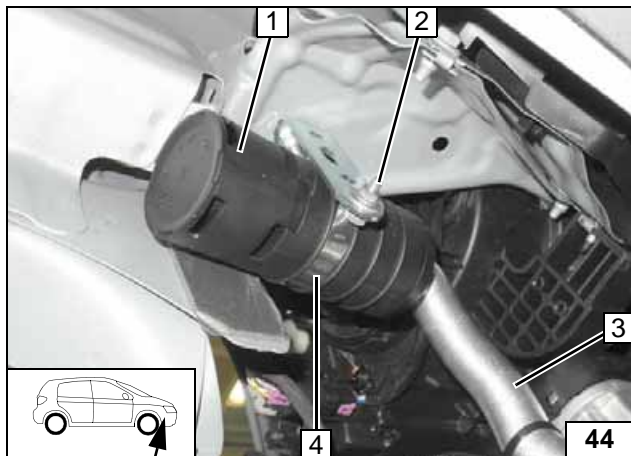

- 1 Silencer
- 2 M5x16 bolt, flanged nut
- 3 Combustion air pipe
- 4 51mm dia. clamp



Installing silencer

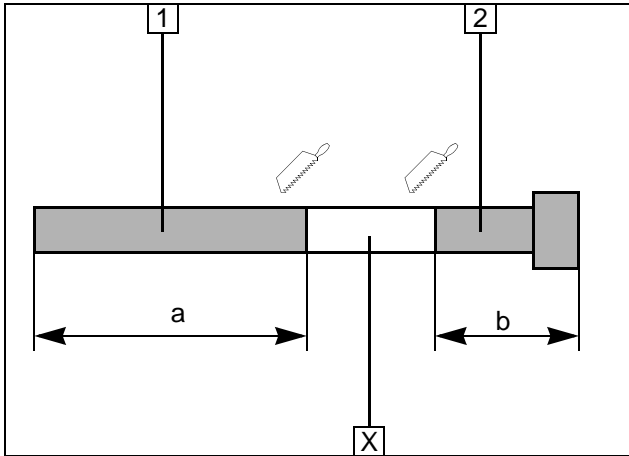
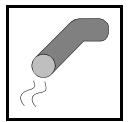

Exhaust Gas

Discard section X.

- 1 Combustion air pipe
a = 380
- 2 Exhaust end section
b = 175

Preparing exhaust pipe

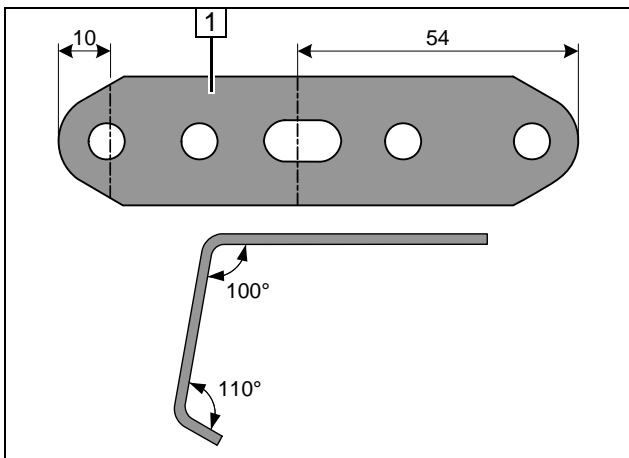

- 1 Perforated bracket

Preparing perforated bracket

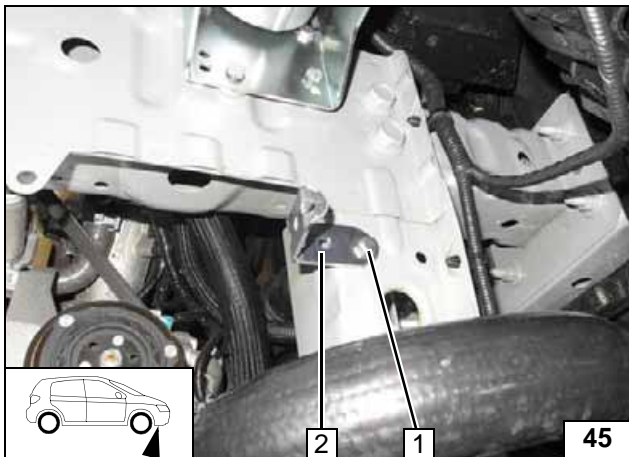

- 1 M6x20 bolt, spring lockwasher on rivet nut
- 2 Perforated bracket

Installing perforated bracket

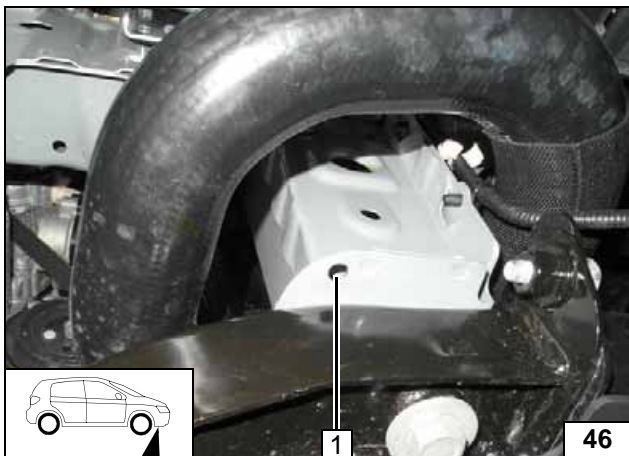

- 1 7mm dia. hole as shown

Hole in cross member

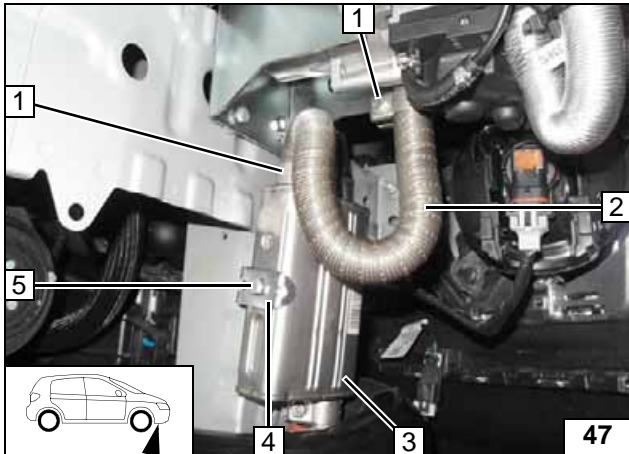
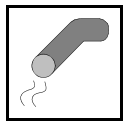

- 1 Hose clamp [2x]
- 2 Exhaust pipe
- 3 Silencer
- 4 Perforated bracket
- 5 M6x16 bolt, spring lockwasher

Installing silencer and ex-haust pipe

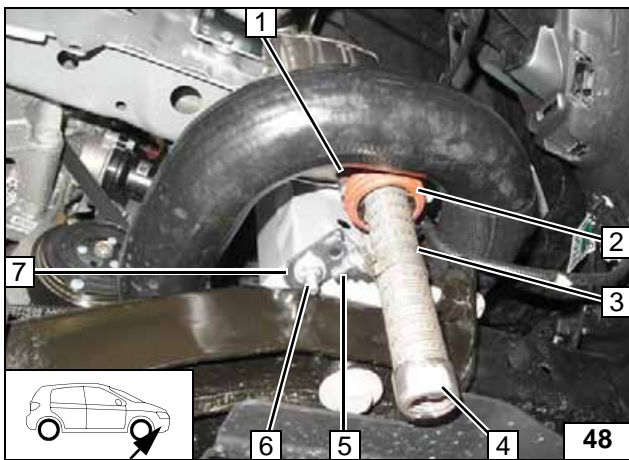

Ensure sufficient distance to adjacent components (min. 20mm), ensure freedom of movement, correct if necessary.



- 1 Hose clamp
- 2 Align spacer bracket with original vehicle hose
- 3 P-clamp
- 4 Exhaust end section
- 5 M6x20 bolt, flanged nut
- 6 M6x20 bolt, large diameter washer, flanged nut
- 7 Angle bracket

Fastening exhaust end section



Coolant Circuit





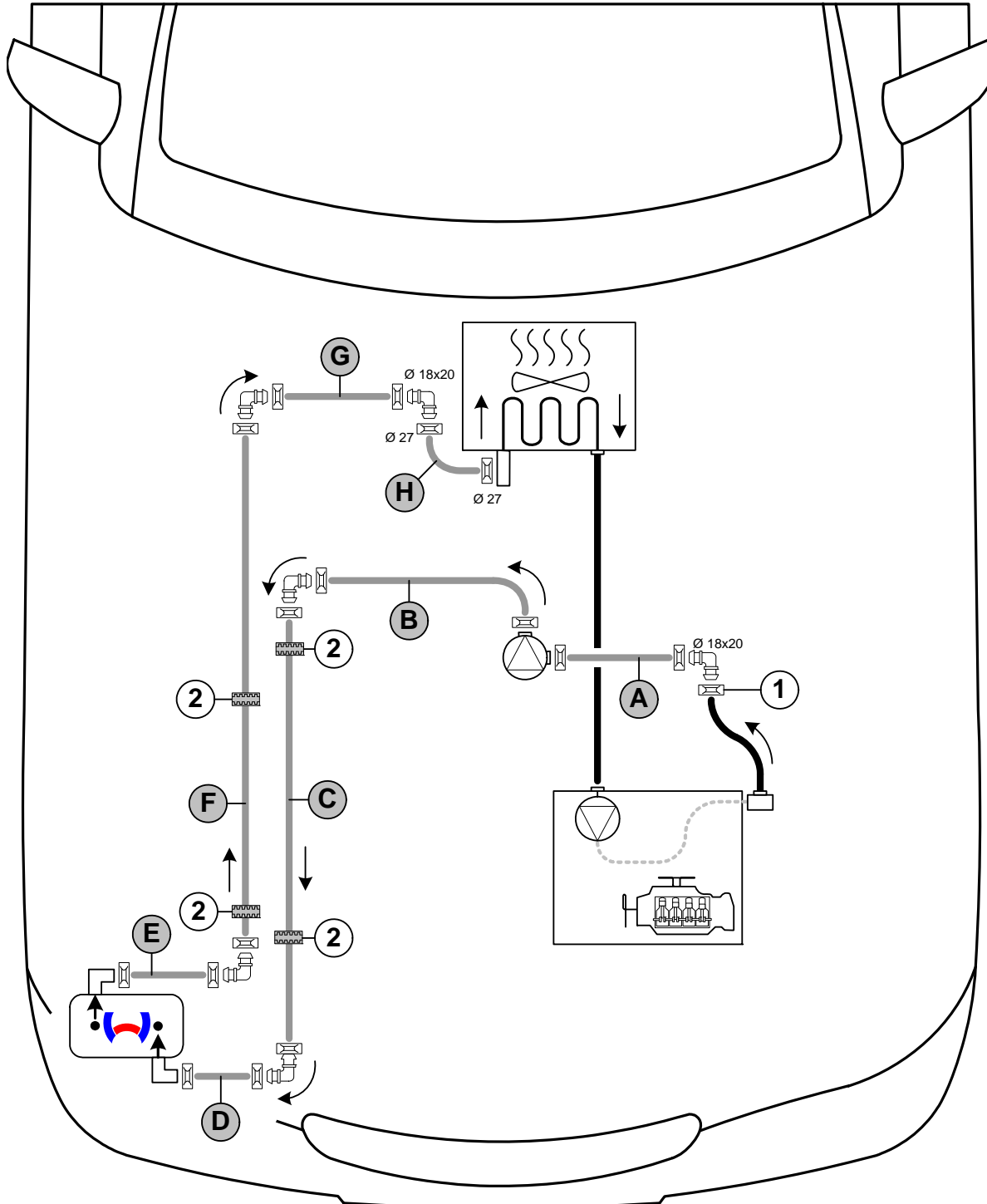

WARNING!

Any coolant running off should be collected in an appropriate container. Install coolant hoses kink-free. Unless specified otherwise, always fasten using cable ties. Position clamps so that other hoses cannot be damaged. When installing the hoses, the heater must be filled with coolant. The connection should be "inline" based on the following diagram:



Hose routing diagram

All non-designated spring clips  = 25mm dia.
 1 = Original vehicle spring clip . 2 = black (sw) rubber isolator .
 All connecting pipes without a specific designation  = 18x18mm dia.



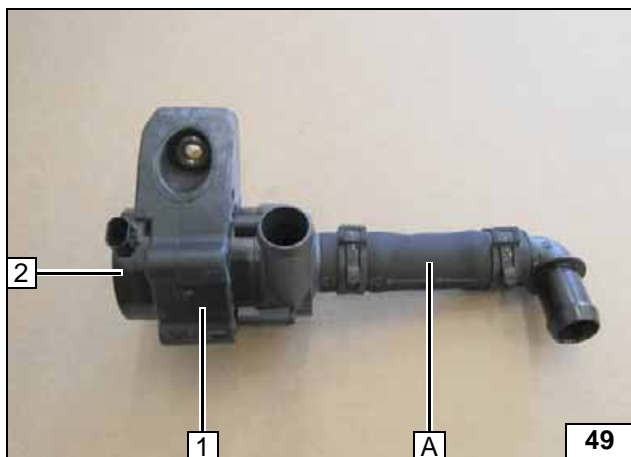
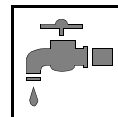

- 1 Mounting of circulating pump
- 2 Circulating pump

Premounting circulating pump

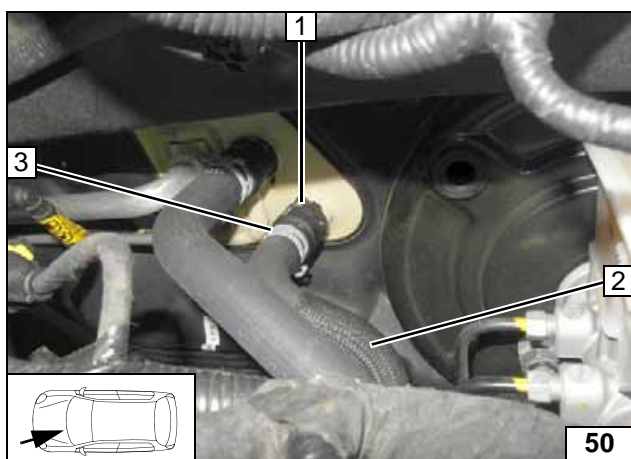

Detach quick-release coupling 1 from heat exchanger inlet connection piece. Pull hose of heat exchanger inlet 2 from quick-release coupling. Quick-release coupling 1 and spring clip 3 will be reused.



Cutting point

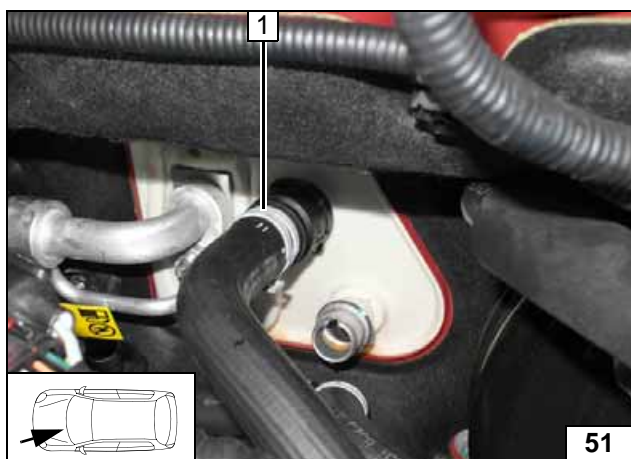

- 1 Position original vehicle spring clip as shown

Turning clamp

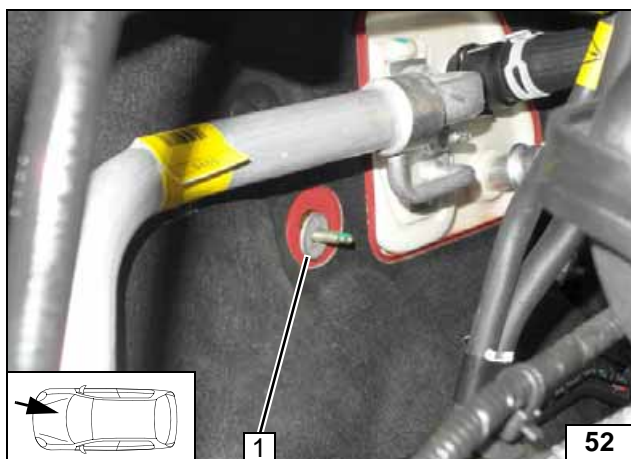

Remove original vehicle nut from stud bolt and discard

- 1 Install large diameter washer with outer dia. $d_a = 21.6\text{mm}$ onto stud bolt



Preparing installation location of circulating pump

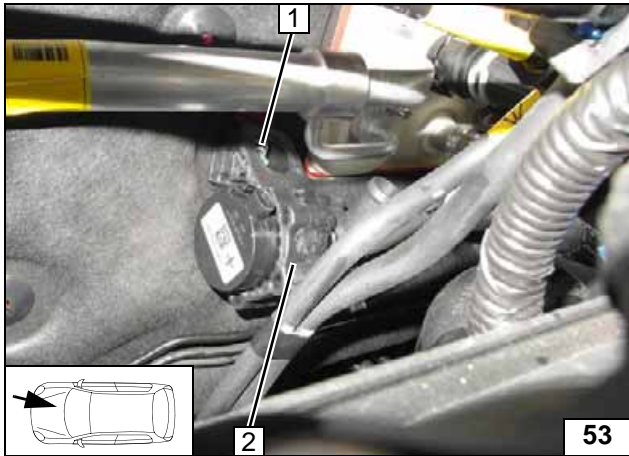

- 1 Flanged nut on original vehicle stud bolt
- 2 Mounting of circulating pump

Installing circulating pump

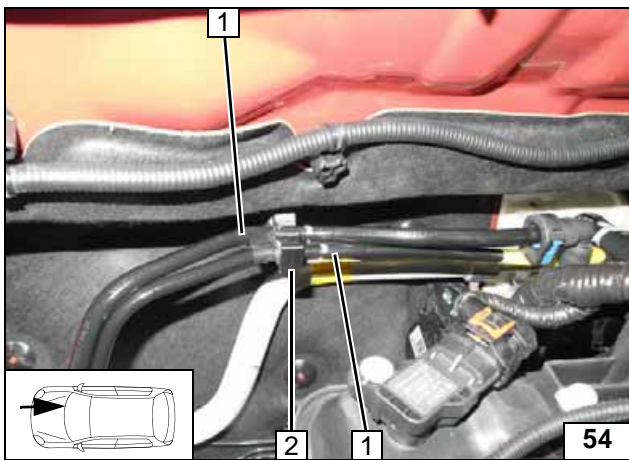

Detach original vehicle fuel lines 1 from original vehicle bracket 2 and re-install again as shown.



Shifting fuel lines

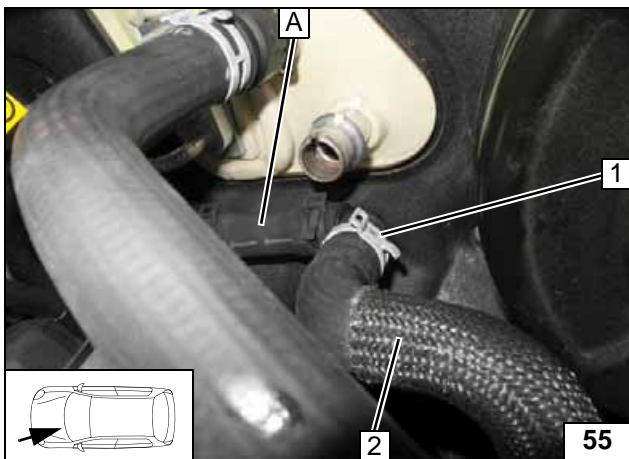

- 1 Original vehicle spring clip
- 2 Hose of engine outlet

Connecting engine outlet

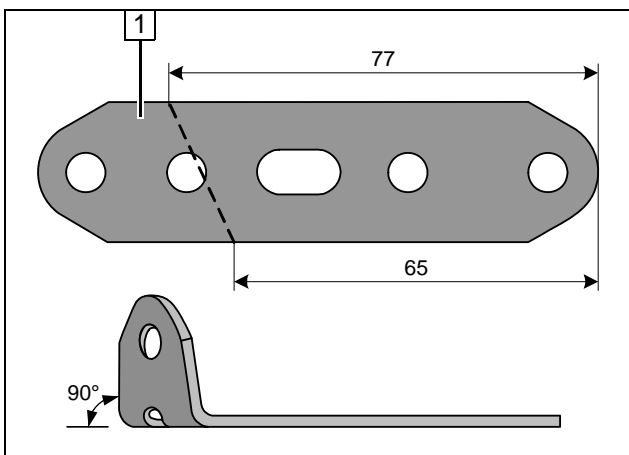

- 1 Perforated bracket

Preparing perforated bracket

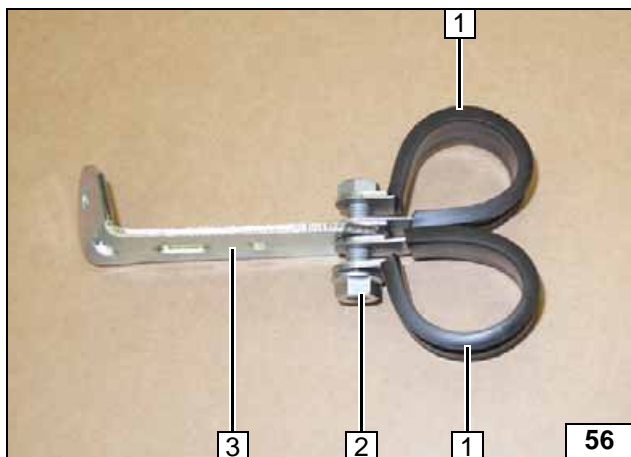

- 1 25mm dia. rubber-coated p-clamp [2x]
- 2 M6x25 bolt, mount flanged nut loosely
- 3 Perforated bracket

Premounting perforated bracket

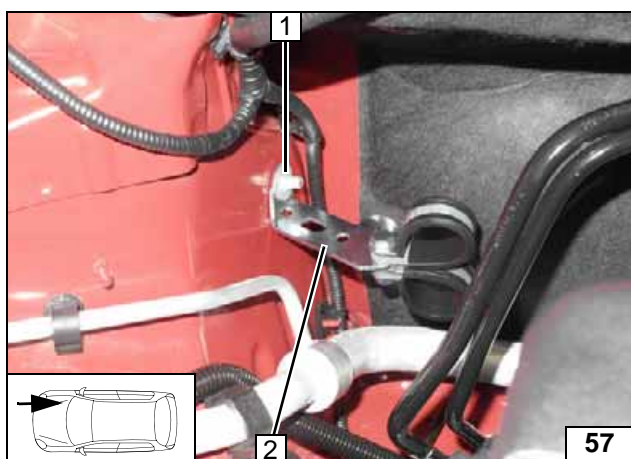

- 1 Original vehicle stud bolt, cap nut
- 2 Perforated bracket

Installing perforated bracket

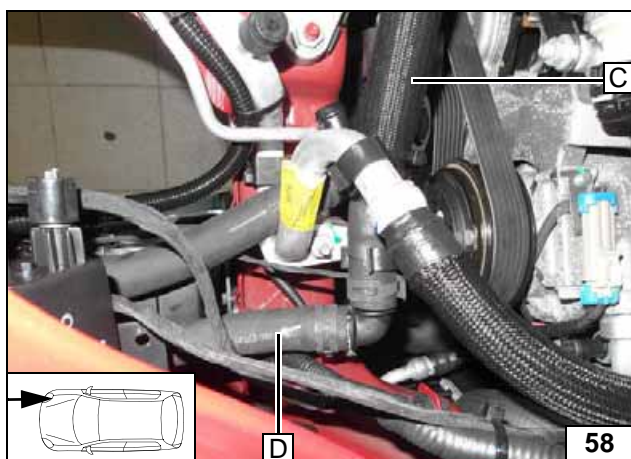

Routing in engine compartment

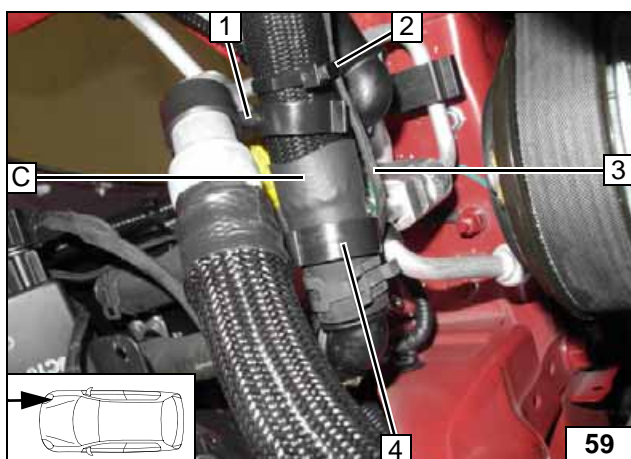

- 1 25x25 hose bracket between A/C line and hose C
- 2 Cable tie
- 3 Wiring harness of circulating pump
- 4 13x23 hose bracket between A/C line and hose C

Routing in engine compartment



- 1 Wiring harness of circulating pump
- 2 Slide on black (sw) rubber isolator and align

Routing in engine compartment

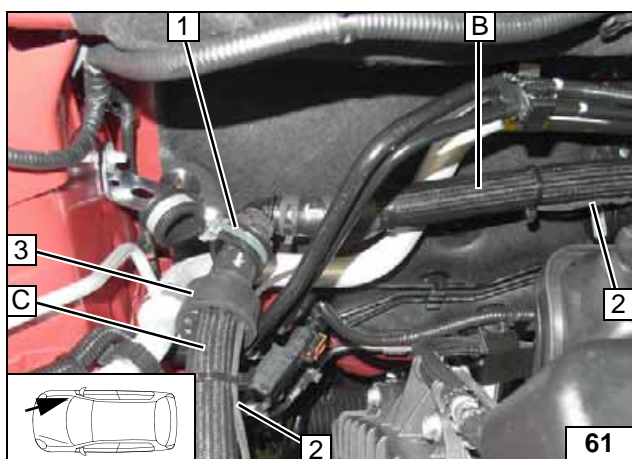

Route hose C through lower rubber-coated p-clamp 1.

- 2 Wiring harness of circulating pump
- 3 Slide on black (sw) rubber isolator and align

Routing in engine compartment

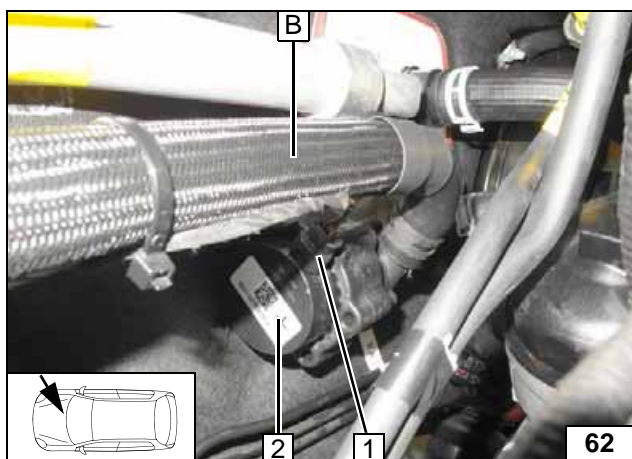

- 1 Attach wiring harness of circulating pump
- 2 Circulating pump

Connection of circulating pump

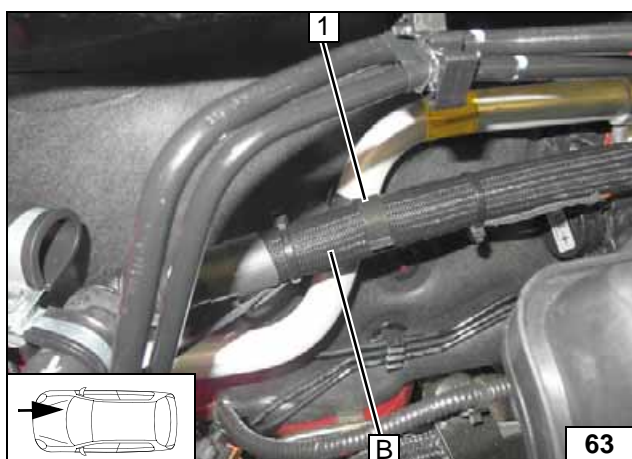

- 1 25x25 hose bracket between A/C line and hose B

Mounting hose bracket

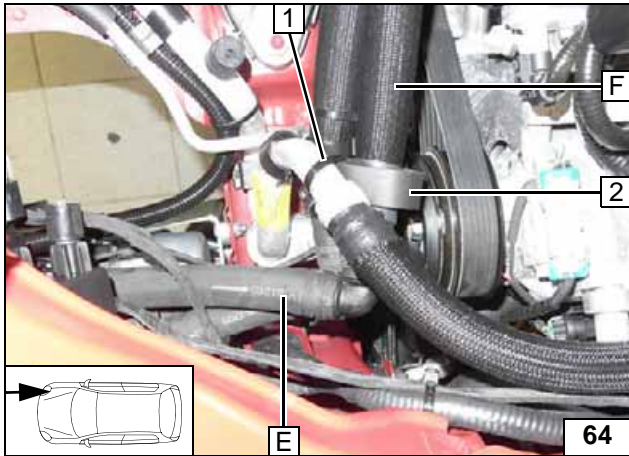

Slide on black (sw) rubber isolator 2 onto hose F and fasten with cable tie 1 to A/C line.

Routing in engine compartment

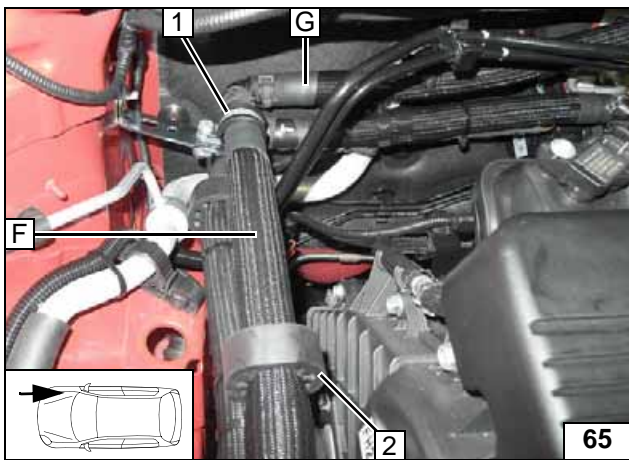

Route hose F through lower rubber-coated p-clamp 1.

2 Slide on black (sw) rubber isolator and align

Routing in engine compartment



1 Coupling piece of heat exchanger inlet

Premounting hose H

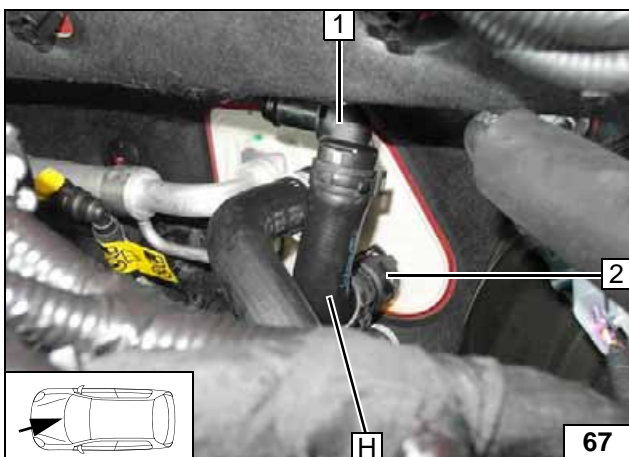

1 Align 90° connecting pipe
2 Coupling piece of heat exchanger inlet

Connection of heat exchanger inlet

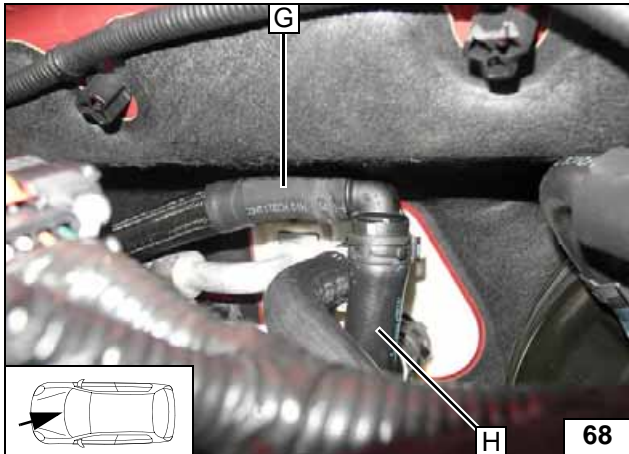

Routing in engine compartment

- 1 25x25 hose bracket between hose of heat exchanger outlet and hose H

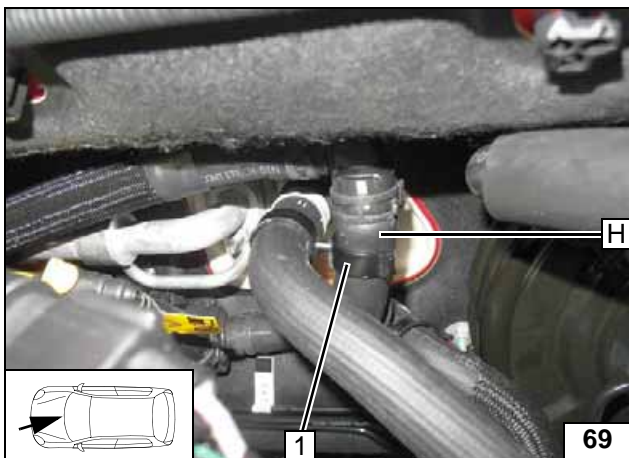

Mounting hose bracket

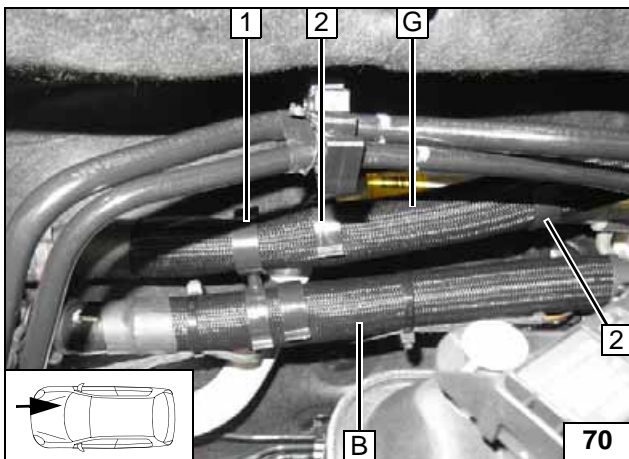

- 1 25x25 hose bracket between hose B and hose G
- 2 25x25 hose bracket between A/C line and hose G [2x]

Mounting hose bracket

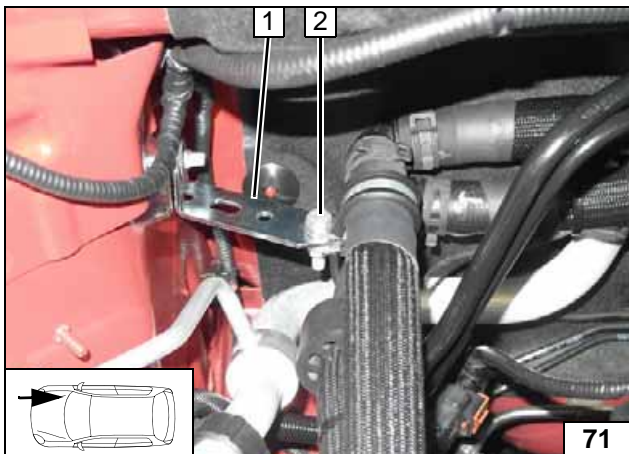

Align hoses. Ensure sufficient distance to adjacent components, ensure freedom of movement, correct if necessary.



- 1 Perforated bracket
- 2 M6x25 bolt, flanged nut

Tightening bolt connections



Align hoses. Ensure sufficient distance from pulley at position **1** (min. 20mm), correct if necessary.



Checking distance

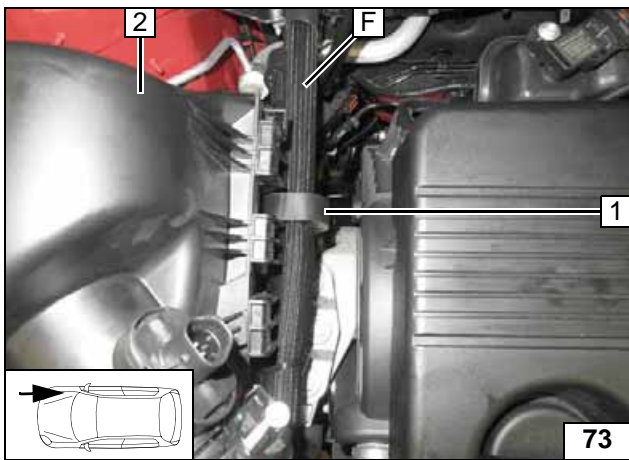

Align rubber isolator **1**. Ensure sufficient distance to adjacent components, ensure freedom of movement, correct if necessary.



2 Air filter box mounted

Aligning hoses

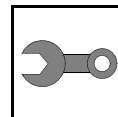

Final Work

WARNING!

Mount removed parts in reverse order. Check all hoses, clamps and all electrical connections for firm seating. Insulate and tie back all loose lines.

Only use manufacturer-approved coolant. Spray the heater components with anti-corrosion wax (Tectyl 100K, Order No. 111329).



- Connect the battery.
- Fill and bleed the coolant circuit according to the vehicle manufacturer's specifications.
- Adjust digital timer, teach Telestart transmitter.
- Make settings on A/C control panel according to the "Operating Instructions for End Customer".
- Place caution label "Switch off parking heater before refuelling" in the area of the filler neck
- For initial startup and function check, see installation instructions

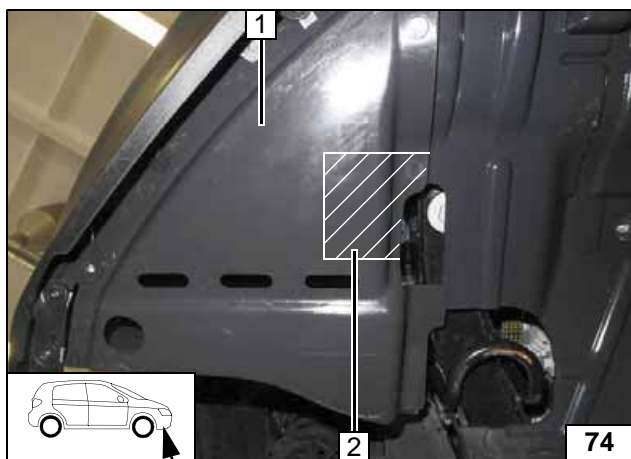

Place wheel well trim 1, copy markings and cut out area.

2 Discard section

Cutting out wheel well trim

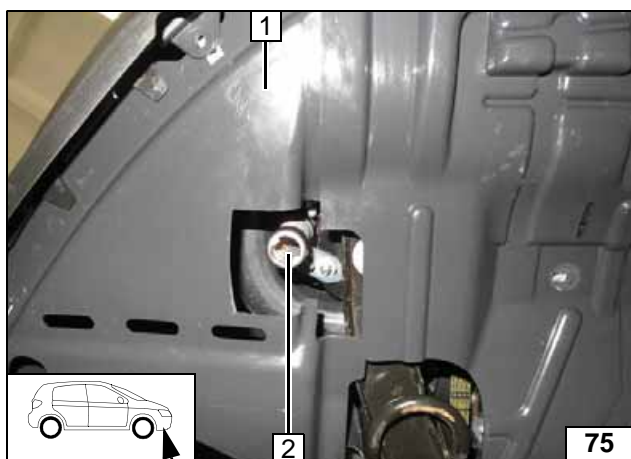

Align exhaust end section 2 flush with wheel well trim 1.

Aligning exhaust end section

Webasto Thermo & Comfort SE
 Postfach 1410
 82199 Gilching
 Germany
 Internet: www.webasto.com
 Technical Extranet:
<http://dealers.webasto.com>

Operating Instructions for End Customer

Please remove page and add to the vehicle operating instructions.

Note:

We recommend matching the heating time to the driving time.

Heating time = driving time

Example:

For a driving time of approx. 20 min. (in one direction), we recommend not exceeding a switch-on time of 20 min.

Passenger compartment monitoring, if installed, must be deactivated in addition to vehicle settings for the heating operation .

Instructions for the deactivation can be taken from the operating instructions of the vehicle.

Before parking the vehicle, make the following settings:

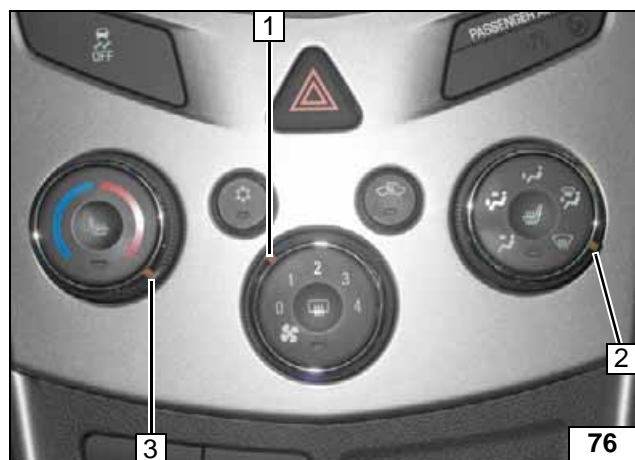

- 1 Set fan to level "1", max. "2"
- 2 Air outlet to windscreen
- 3 Set temperature to "max."



A/C control panel

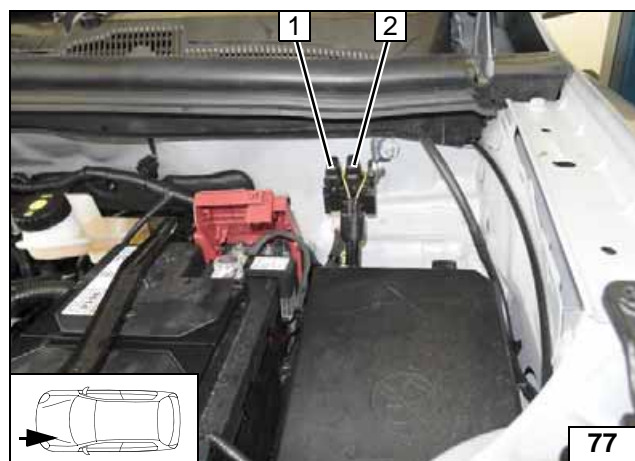

- 1 20A heater fuse F1
- 2 30A main fuse F2 of passenger compartment

Fuses of engine compartment

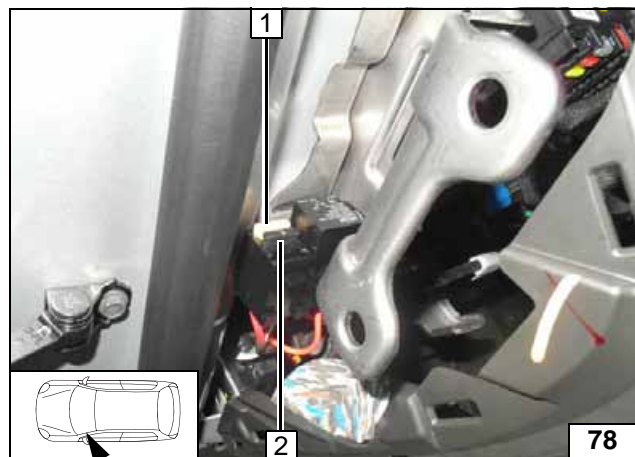

- 1 25A fan fuse F4
- 2 1A fuse F3 of heater control

Fuses of passenger compartment

