

# Water Heater

## Thermo Top Evo Parking Heater



# Installation Documentation

## Nissan Note

### Validity

Manufacturer	Model	Type	EG-BE No. / ABE
Nissan	Note	E12	e11 * 2007 / 46 * 0753 * ...

Motorisation	Fuel	Transmission type	Output in kW	Displacement in cm <sup>3</sup>	Engine code
1.2 P	Petrol	5-speed SG	59	1198	HR12
1.2 P	Petrol	5-speed SG	72	1198	HR12
1.2 P	Petrol	AG	72	1198	HR12

SG = Manual transmission  
 AG = Automatic transmission

**From Model Year 2014**  
**Left-hand drive vehicle**

**Verified equipment variants:** Automatic air-conditioning  
 Front fog light  
 Start / Stop  
 Intelligent key with start button  
 Euro 5  
 Daytime running lights

**Not verified:** Manual air-conditioning  
 Passenger compartment monitoring  
 Headlight washer system

**Total installation time:** approx. 7 hours

# Nissan Note

## Table of Contents

Validity	1	Preparing Bracket	14
Necessary Components	2	Preparing Installation Location	15
Installation Overview	2	Installing bracket	15
Notes on Total Installation Time	2	Preparing Heater	17
Information on Operating and Installation Instructions	3	Installing Heater	18
Notes on Validity	4	Mechanical System for Vehicles With SG or AG / Without	
Technical Instructions	4	Electrical Auxiliary Heater	19
Explanatory Notes on Document	4	Preparing Bracket	19
Preliminary Work	5	Installing Bracket	19
Heater Installation Location	5	Preparing Heater	21
Preparing Electrical System	6	Installing Heater	22
Electrical System for Manual Transmission	8	Fuel for All Vehicles	23
Electrical System for Automatic Transmission	9	Coolant circuit of manual transmission	27
Fan Controller for All Vehicles	10	Exhaust for Manual Transmission	33
MultiControl CAR Option	12	Coolant Circuit for Automatic Transmission	35
Remote Option (Telestart)	12	Exhaust for Automatic Transmission	41
Remote Option Thermo Call	13	Combustion Air for All Vehicles	43
Radiator Grille Removal Instructions	14	Final Work	44
Mechanical System for Vehicles With SG / With Electrical		Template for Fuel Standpipe	45
Auxiliary Heater	14	Operating Instructions for End Customer	46

## Necessary Components

- Basic delivery scope *Thermo Top Evo* based on price list
- Installation kit for Nissan Note 2014 Petrol: **1322166B**
- Heater control in accordance with price list and upon consultation with end customer
- In case of Telestart, indicator lamp in accordance with price list and upon consultation with end customer

## Installation instructions:

- Arrange for the vehicle to be delivered with the tank only about ¼ full!
- The installation location of the push button in the case of Telestart or Thermo Call should be confirmed with the end customer.
- Depending on the space required and the manufacturer's instructions on the vehicle, we recommend the use of a vehicle battery with a higher electrical capacity!

## Installation Overview

### Legend:

1. Heater
2. Fuse holder of engine compartment
3. Relay and fuse holder of passenger compartment
4. Circulating pump
5. MultiControl CAR
6. Metering pump

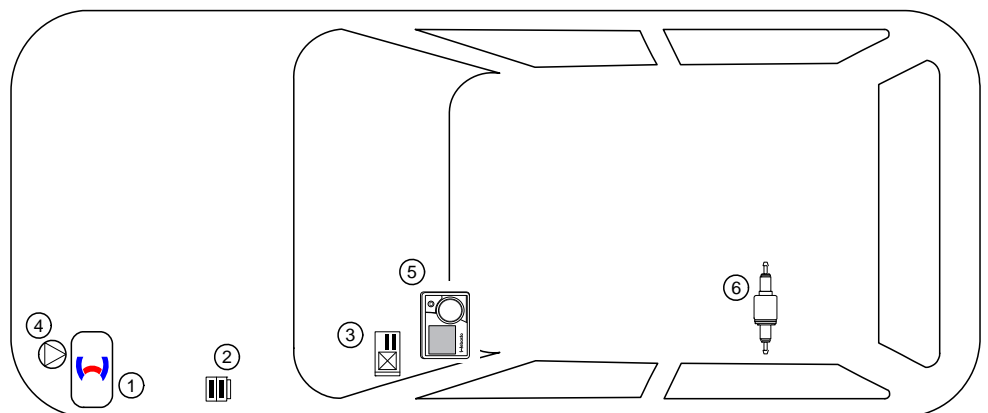

## Notes on Total Installation Time

The total installation time includes the time needed for mounting and demounting of the vehicle-specific components, the heater specific installation time and all other times required for the system integration and initial start-up of the heater.

The total installation time may vary for vehicle equipment other than provided.

## Information on Operating and Installation Instructions

### 1 Important Information (not complete)

#### 1.1 Installation and Repair



The improper installation or repair of Webasto heating and cooling systems can cause fire or the leakage of deadly carbon monoxide, leading to serious injury or death.



To install and repair Webasto heating and cooling systems you need to have completed a special company training course and have the appropriate technical documentation, special tools and special equipment.



Installation and repair may ONLY be carried out by persons trained and certified in a Webasto training course. NEVER try to install or repair Webasto heating or cooling systems if you have not completed a Webasto training course, you do not have the necessary technical skills and you do not have the technical documentation, tools and equipment available to ensure that you can complete the installation and repair work properly.

Only use genuine Webasto parts. See the Webasto air and water heaters accessories catalogue for this purpose.

#### 1.2 Operation

To ensure safe operation, we recommend having the heater checked every two years by an authorised Webasto dealer, especially when used over a long period and/or under extreme environmental conditions.

Do not operate the heater in closed rooms due to the danger of poisoning and suffocation.

Always switch off the heater before refuelling.

The heater may only be used with the prescribed fuel Diesel (DIN EN 590) or petrol (DIN EN 228).

The heater may not be cleaned with a high-pressure cleaner.

#### 1.3 Please note

ALWAYS follow all Webasto installation and operating instructions and observe all warnings.

To become familiar with and understand all functions and properties of the heater, the operating instructions must be read carefully and observed at all times.

For proper, safe installation and repair work, the installation instructions with all warnings and safety information must be carefully read and observed at all times. Please always contact a workshop authorised by Webasto for all installation and repair work.

#### Important

**Webasto shall assume no liability for defects, damage and injuries resulting from a failure to observe the installation, repair and operating instructions of the information contained in them.**

**This liability exclusion particularly applies to improper installations and repairs, installations and repairs by untrained persons or in the case of a failure to use genuine spare parts.**

**The liability due to culpable disregard to life, limb or health and due to damage or injuries caused by a wilful or reckless breach of duty remain unaffected, as does the obligatory product liability.**

**Installation should be carried out according to the general, standard rules of technology. Unless specified otherwise, fasten hoses, lines and wiring harnesses to original vehicle lines and wiring harnesses using cable ties. Insulate loose wire ends and tie back. Connectors on electronic components must audibly snap into place during assembly.**

**Sharp edges should be fitted with rub protection. Spray unfinished body areas, e.g. drilled holes, with anti-corrosion wax (Tectyl 100K, Order No. 111329).**

**Observe the instructions and guidelines of the respective vehicle manufacturer for demounting and mounting vehicle specific components!**

**The initial startup is to be executed with the Webasto Thermo Test Diagnosis.**

**When installing a programmable control module (e.g. a PWM Gateway), the corresponding settings must be checked or adjusted.**

### 2 Statutory regulations governing installation

Guidelines	Thermo Top Evo
Heating Directive ECE R122	E1 00 0258
EMC Directive ECE R10	E1 04 5627

#### Note

The regulations of these guidelines are binding in the scope of the Directive 70/156/EEC and/or 2007/46/EC (for new vehicle models from 29/04/2009) and should also be observed in countries in which there are no special regulations.

#### Important

Failure to follow the installation instructions will result in the invalidation of the type approval for the heater and therefore invalidation of the general **homologation of the vehicle**.

#### Note

The heater is licensed in accordance with paragraph 19, section 3, No. 2b of the StVZO (German Road Traffic Licensing Authority).

#### 2.1 Excerpt from ECE regulation 122 (heating system) para-

#### graph 5 for the installation of the heater

Beginning of excerpt.

#### ANNEX VII

### REQUIREMENTS FOR COMBUSTION HEATERS AND THEIR INSTALLATION

#### 1. GENERAL REQUIREMENTS

1.7.1. A clearly visible tell-tale in the operator's field of view shall inform when the combustion heater is switched on or off.

#### 2. VEHICLE INSTALLATION REQUIREMENTS

##### 2.1. Scope

2.1.1. Subject to paragraph 2.1.2. combustion heaters shall be installed according to the requirements of this Annex.

2.1.2. Vehicles of category O having liquid fuel heaters are deemed to comply with the requirements of this Annex.

##### 2.2. Positioning of heater

2.2.1. Body sections and any other components in the vicinity of the heater must be protected from excessive heat and the possibility of fuel or oil contamination.

2.2.2. The combustion heater shall not constitute a risk of fire, even in the case of overheating. This requirement shall be deemed to be fulfilled if the installation ensures an adequate distance to all parts and suitable ventilation, by the use of fire resistant materials or by the use of heat shields.

2.2.3. In the case of M2 and M3 vehicles, the heater must not be positioned in the passenger compartment. However, an installation in an effectively sealed envelope which also complies with the conditions in paragraph 2.2.2 may be used.

2.2.4. The label referred to in paragraph 1.4 or a duplicate, must be positioned so that it can be easily read when the heater is installed in the vehicle.

2.2.5. Every reasonable precaution should be taken in positioning the heater to minimise the risk of injury and damage to personal property.

##### 2.3. Fuel supply

2.3.1. The fuel filler must not be situated in the passenger compartment and must be provided with an effective cap to prevent fuel spillage.

2.3.2. In the case of liquid fuel heaters, where a supply separate to that of the vehicle is provided, the type of fuel and its filler point must be clearly labelled.

2.3.3. A notice, indicating that the heater must be shut down before refuelling, must be affixed to the fuelling point. In addition a suitable instruction must be included in the manufacturer's operating manual.

##### 2.4. Exhaust system

2.4.1. The exhaust outlet must be located so as to prevent emissions from entering the vehicle through ventilators, heated air inlets or opening windows.

##### 2.5. Combustion air inlet

2.5.1. The air for the combustion chamber of the heater must not be drawn from the passenger compartment of the vehicle.

2.5.2. The air inlet must be so positioned or guarded that blocking by rubbish or luggage is unlikely.

##### 2.6. Heating air inlet

2.6.1. The heating air supply may be fresh or recirculated air and must be drawn from a clean area not likely to be contaminated by exhaust fumes emitted either by the propulsion engine, the combustion heater or any other vehicle source.

2.6.2. The inlet duct must be protected by mesh or other suitable means.

##### 2.7. Heating air outlet

2.7.1. Any ducting used to route the hot air through the vehicle must be so positioned or protected that no injury or damage could be caused if it were to be touched.

2.7.2. The air outlet must be so positioned or guarded that blocking by rubbish or luggage is unlikely.

End of excerpt.

In multilingual versions the German language is binding.

# Nissan Note

## Notes on Validity

This installation documentation applies to Nissan Note Petrol vehicles - for validity, see page 1 - from model year 2014 and later, assuming technical modifications to the vehicle do not affect installation, any liability claims excluded. Depending on the vehicle version and equipment, modifications may be necessary during installation with respect to this installation documentation.

Vehicle and engine types, equipment variants and other specifications not listed in this installation documentation have not been tested. However, installation according to this installation documentation may be possible.

## Technical Instructions

### Special Tools

- Hose clamp pliers for self-clamping hose clamps
- Hose clamp pliers for Clic hose clamps of type W
- Automatic wire stripper 0.2 - 6mm<sup>2</sup>
- Crimping pliers for cable lug / tab connector 0.5 - 6mm<sup>2</sup>
- Torque wrench for 2.0 - 10 Nm
- Hose clamping pliers
- Metric thread-setter kit
- Webasto Thermo Test diagnosis with current software

### Dimensions

- All dimensions are in mm

### Tightening torque values

- Tightening torque values for 5x13 heater bolts and 5x11 heater stud bolts = 8Nm.
- Tightening torque of 5x15 retaining plate of water connection piece bolt = 7Nm.
- Tighten other bolt connections in accordance with manufacturer's instructions or in accordance with state-of-the-art-technology.

## Explanatory Notes on Document

You will find an identification mark on the outside top right corner of the page in question to provide you with a quick overview of the individual working steps.

Special features are highlighted using the following symbols:

**Mechanical system**



**Specific risk of injury or fatal accidents**



**Electrical system**



**Specific risk due to electrical voltage**



**Coolant circuit**

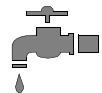

**Specific risk of damage to components**



**Combustion air**

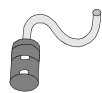

**Specific risk of fire or explosion**



**Fuel**



**Reference to general installation instructions of the Webasto components or to the manufacturer's vehicle-specific documents**



**Reference to a special technical feature**



**Exhaust gas**



**The arrow in the vehicle icon indicates the position on the vehicle and the viewing angle**

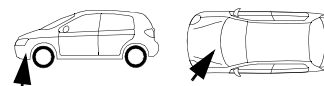

**Software**



**Tightening torque according to the manufacturer's vehicle-specific documents**



## Nissan Note

### Preliminary Work

#### Vehicle

- Open the fuel tank cap.
- Ventilate the fuel tank.
- Close the fuel tank cap again.
- Depressurise the cooling system.
- Unclamp the battery and remove completely with the battery carrier.
- Remove the air filter together with the intake hose (only in case of 59kW).
- Remove the engine control unit (only in case of 59kW).
- Detach the central electrical box and put it aside.
- Detach the wheel well trim on the front left.
- Remove the radiator grille (see removal instructions).
- Remove the bumper.
- Remove the rear bench seat.
- Remove the instrument panel trim on the driver's side.
- Detach the passenger compartment fuse and relay box and put it aside.
- Remove the air outlet trim of the centre console.
- Remove the A/C control panel.

The following work should only be performed during the corresponding installation sequence:

- Remove the fuel-tank sending unit in accordance with the manufacturer's instructions.

#### Heater

- Remove years that do not apply from the type and duplicate label.
- Attach the duplicate label (type label) in the appropriate place inside the engine compartment.

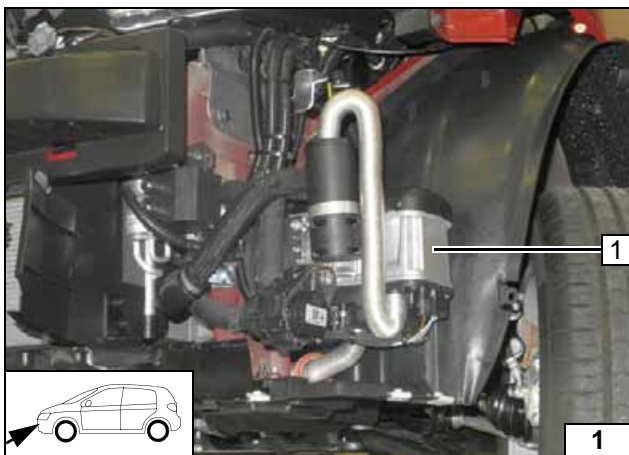

#### Heater Installation Location

Figure shows manual transmission!

- 1 Heater



**Installation  
location**

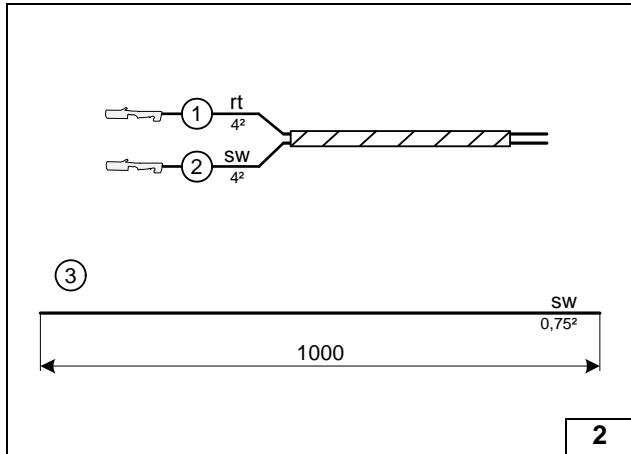
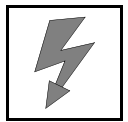

### Preparing Electrical System

Wire sections retain their numbering in the entire document.

Produce all following electrical connections as shown in the wiring diagram.

Pull wire ③ into 4mm dia. protective sleeving!

- ① Red (rt) wire of fan wiring harness
- ② Black (sw) wire of fan wiring harness



### Assigning wires

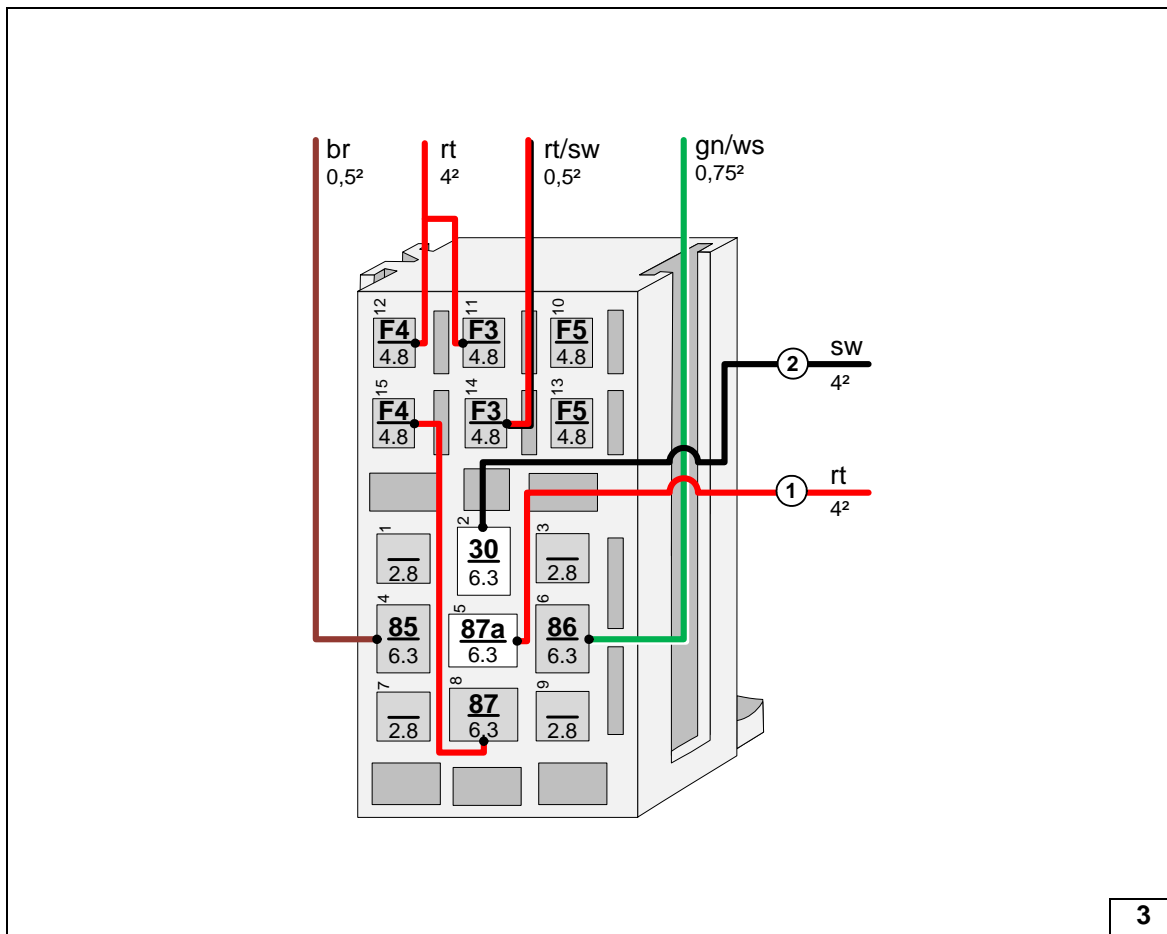

### Connecting wires to passenger compartment relay and fuse holder

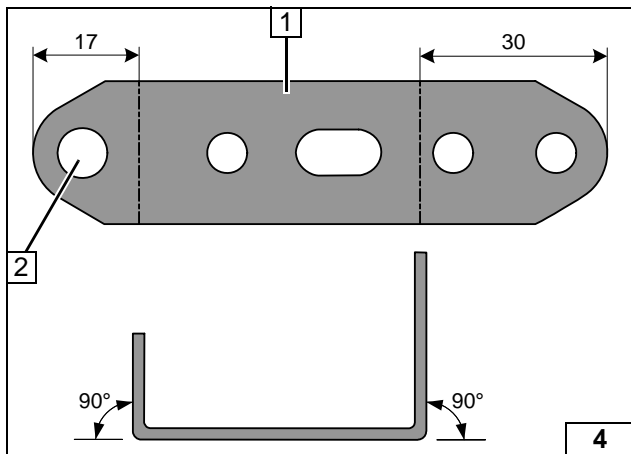

- 1 Perforated bracket
- 2 Drill out hole to 8 mm dia.



### Preparing perforated bracket

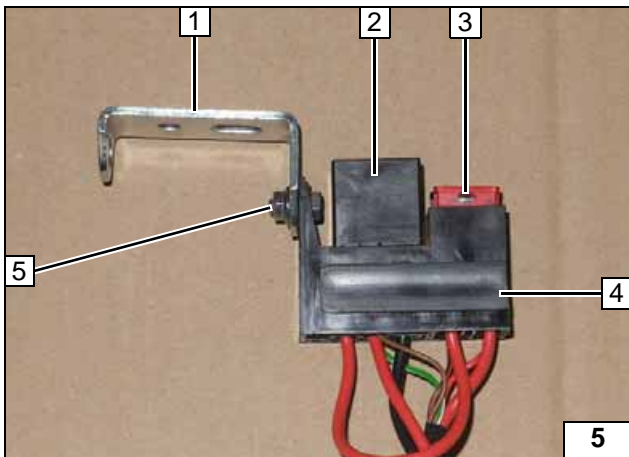

- 1 Perforated bracket
- 2 K1 relay
- 3 Fuse F4 10A
- 4 Relay and fuse holder of passenger compartment
- 5 M5x16 bolt, large diameter washer [2x], nut

**Preparing relay and fuse holder of passenger compartment**

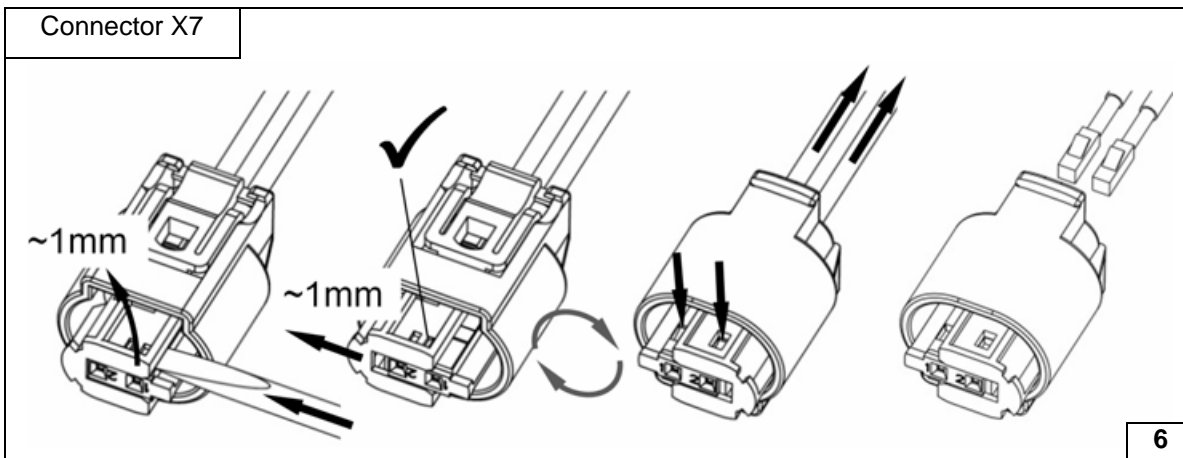

**Removing metering pump connector**



## Electrical System for Manual Transmission

### Positive wire

- 1 Positive wire on positive battery terminal

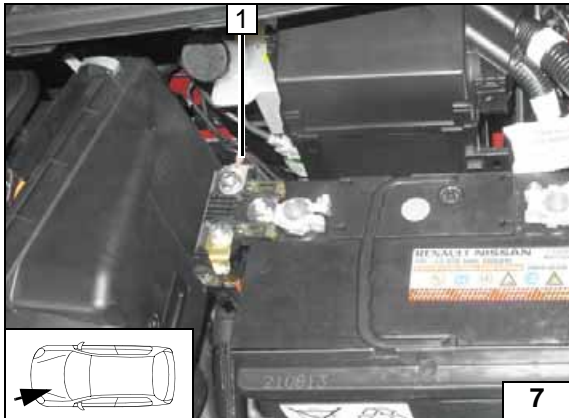

### Wiring harness pass through

- 1 Protective rubber plug
- 2 Wiring harnesses of heater, heater control

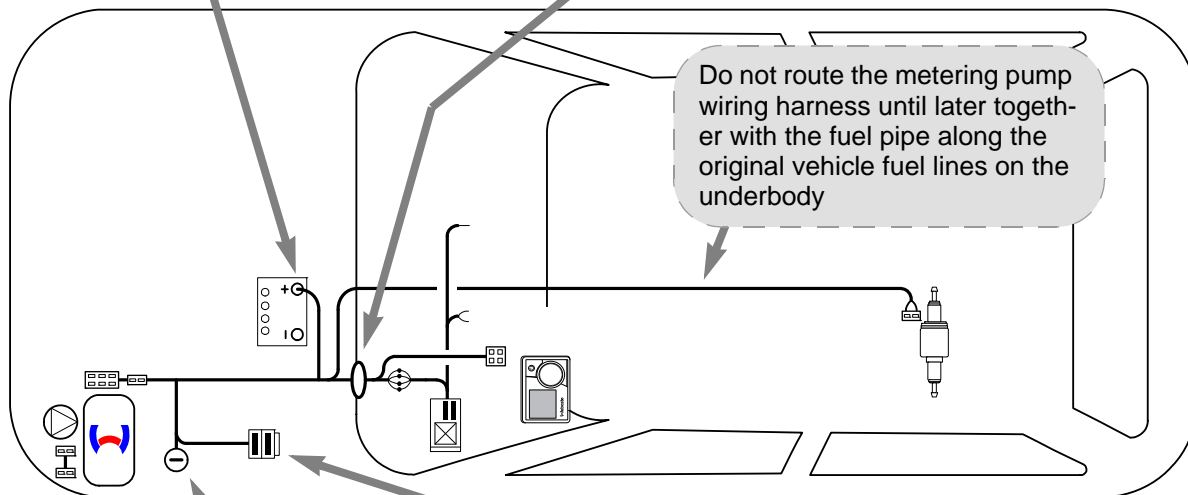
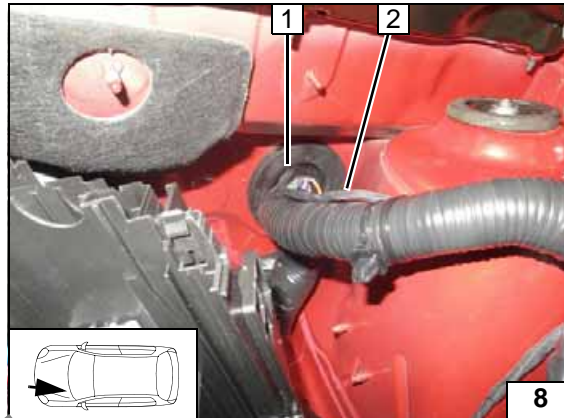

Wiring harness routing diagram

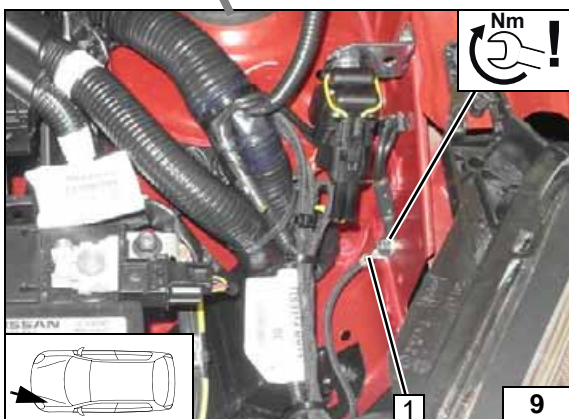

### Earth wire

- 1 Earth wire on original vehicle earth support point

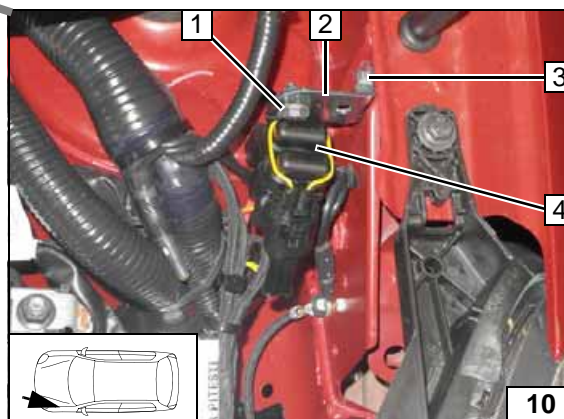

### Fuse holder of engine compartment

- 1 M5x16 bolt, large diameter washer [2x], retaining plate of fuse holder, nut
- 2 Angle bracket
- 3 M6x20 bolt, flanged nut, existing hole
- 4 F1-2 fuses







## Electrical System for Automatic Transmission

### Positive wire

- 1 Positive wire on positive battery terminal

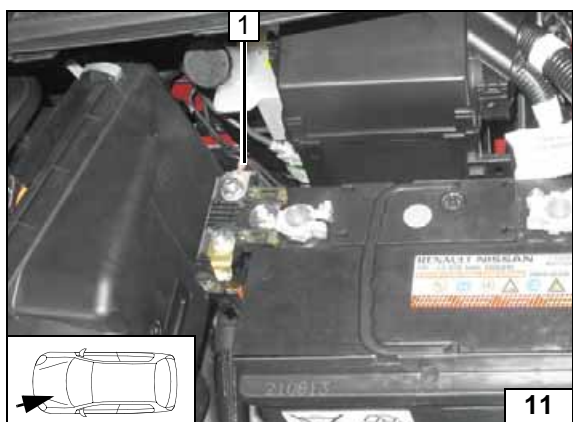

### Wiring harness pass through

- 1 Protective rubber plug

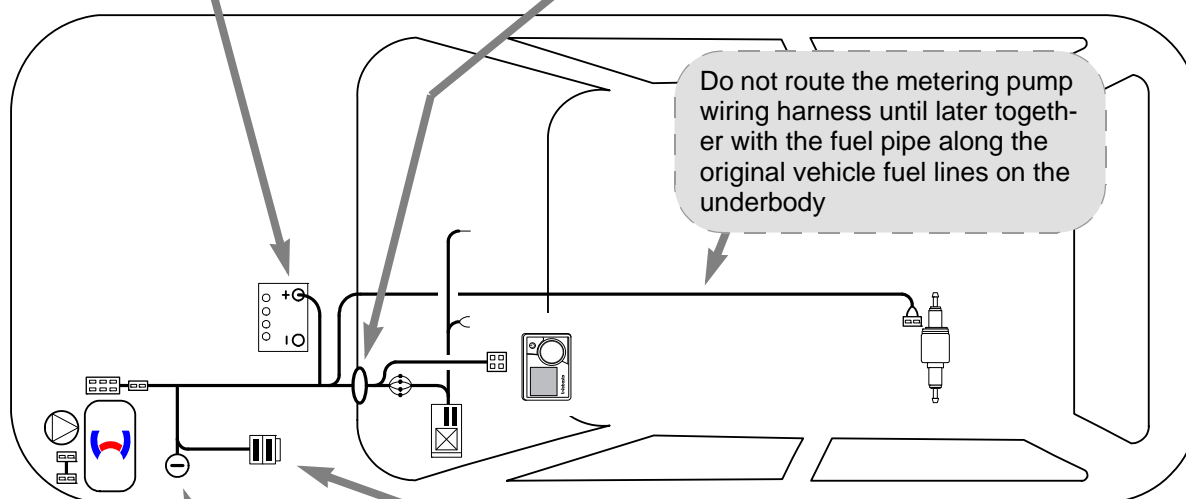
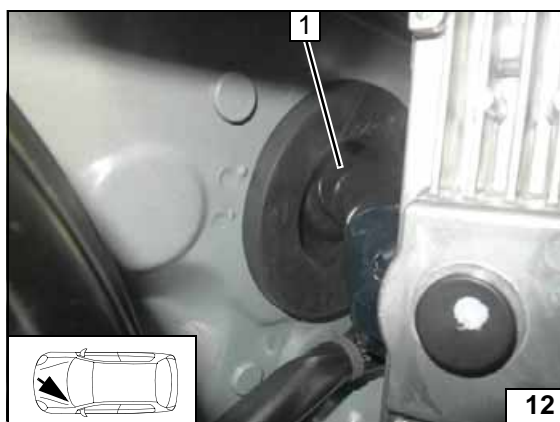

Wiring harness routing diagram

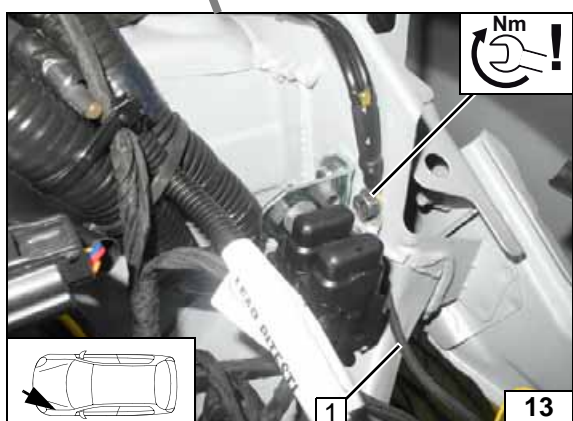

### Earth wire

- 1 Earth wire on original vehicle earth support point

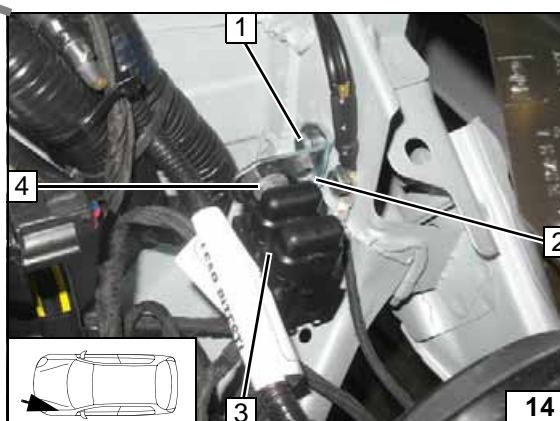

### Fuse holder of engine compartment

- 1 M6x20 bolt, spring lockwasher, existing threaded hole
- 2 Angle bracket
- 3 F1-2 fuses
- 4 M5x16 bolt, large diameter washer [2x], retaining plate of fuse holder, nut



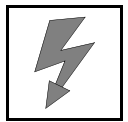

Fan Controller for All Vehicles

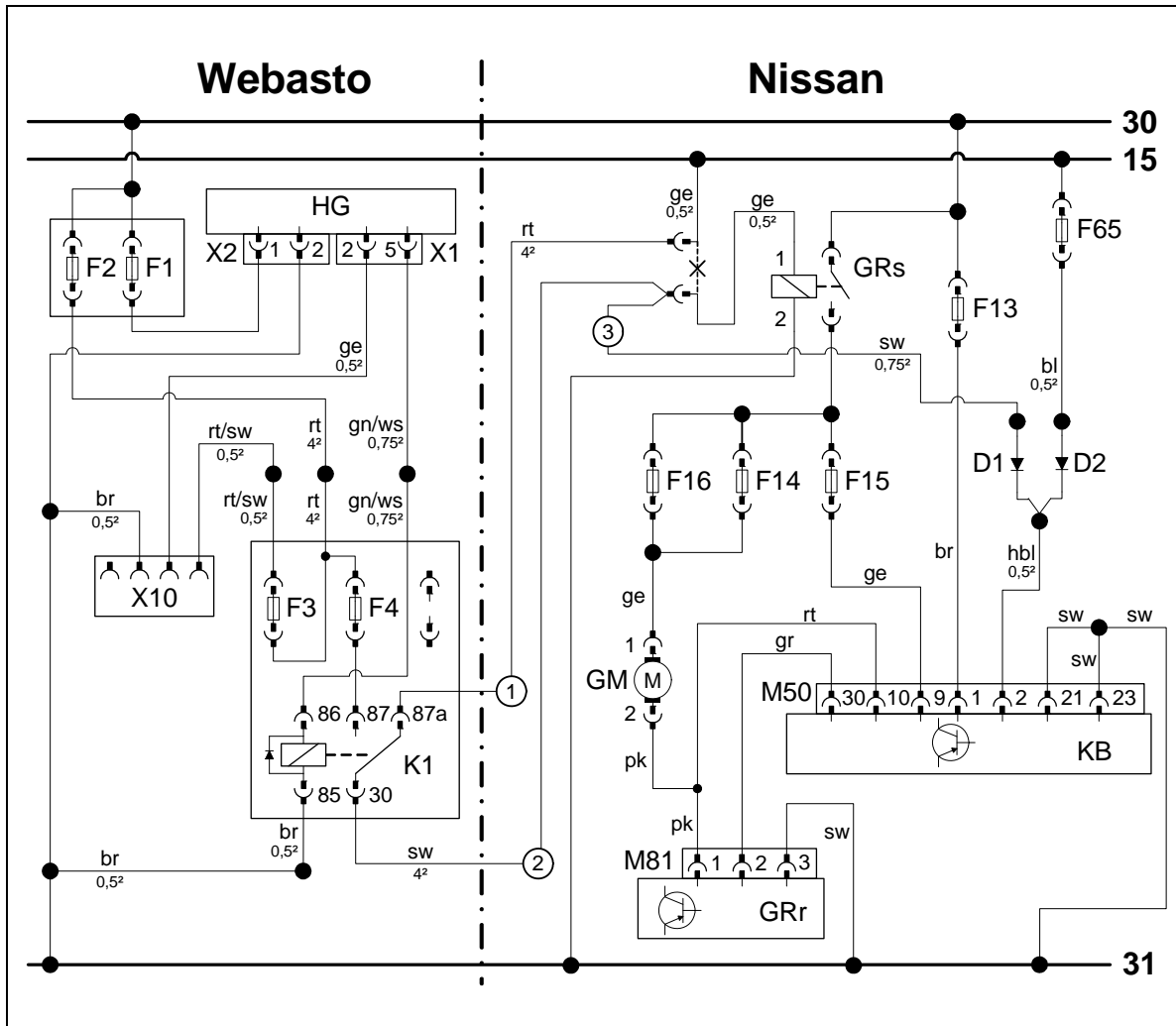

Wiring diagram

Webasto components		Vehicle components		Colours and symbols	
HG	TT-Evo heater	F65	10 A fuse	rt	red
X1	6-pin heater connector	GRs	Fan relay	sw	black
X2	2-pin heater connector	F13	10 A fuse	ge	yellow
F1	20A fuse	F16	15A fuse	gn	green
F2	30A fuse	F14	15A fuse	br	brown
X10	4-pin connector of heater control	F15	10 A fuse	ws	white
F3	1A fuse	GM	Fan motor	bl	blue
F4	10 A fuse	KB	A/C control unit	hbl	light blue
K1	Fan relay	M50	40-pin KB connector	gr	grey
D1	3A diode	GRr	Fan controller	pk	pink
D2	3A diode	M81	Connector GRr		
				X	Cutting point
Wiring colours may vary.					

Legend

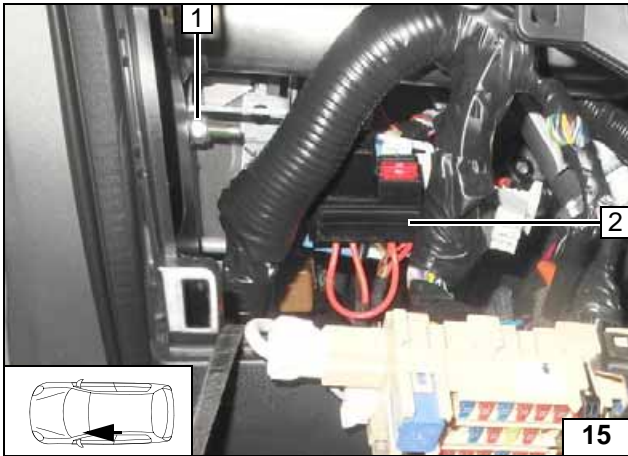
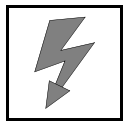

- 1 M8 flanged nut on original vehicle stud bolt
- 2 Relay and fuse holder of passenger compartment

**Installing relay and fuse holder of passenger compartment**

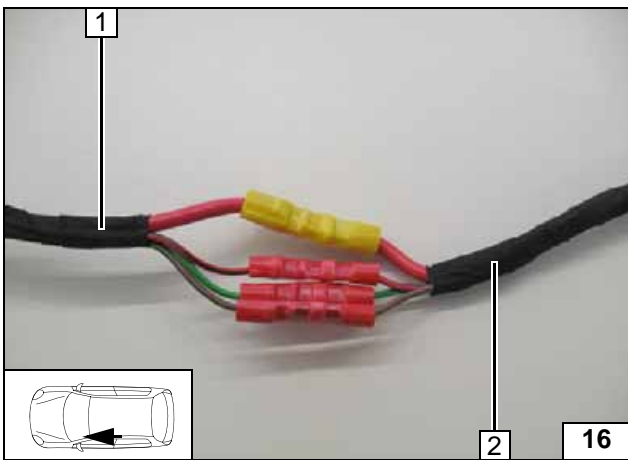

- 1 Wiring harness of passenger compartment relay and fuse holder
- 2 Wiring harness of heater

**Connecting wiring harnesses using same colour wires**

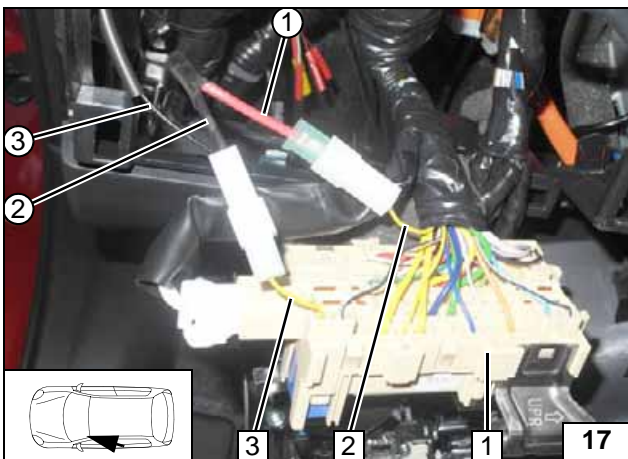

Connection at original vehicle fan relay. Route additional black (sw) wire ⑤ in protective sleeving to the A/C control unit.

- 1 Central electrical box
- 2 Yellow (ge) wire of Terminal 15
- 3 Yellow (ge) wire of fan relay GRs/Pin 1
- ④ Red (rt) wire of K1/87a, fan wiring harness
- ⑤ Black (sw) wire of K1/30, fan wiring harness

**Connecting the fan relay**

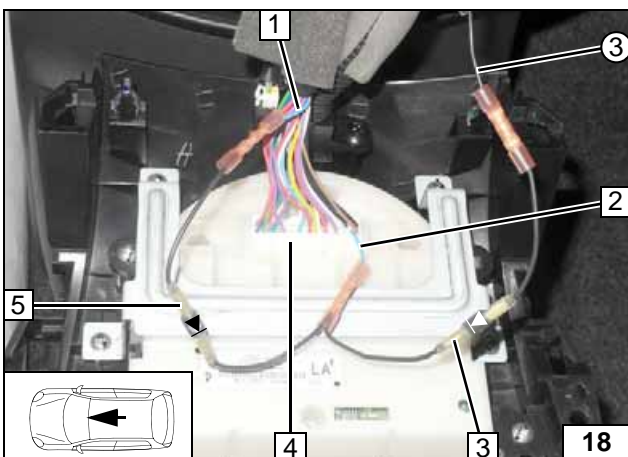

Connection to 40-pin connector M50 4 from A/C control unit. Produce connections as shown in wiring diagram. Pay attention to the diode direction of flow.

- 1 Light blue (hbl) wire from fuse F65
- 2 Light blue (hbl) wire of 40-pin connector M50, pin 2
- 3 Diode D1
- 5 Diode D2
- ③ Additional black (sw) wire

**Connection to A/C control unit**

View of connector M50 4 on wire side

1	2	3	4	5	6	7	8	9	10	11	12	13	14	15	16	17	18	19	20
21	22	23	24	25	26	27	28	29	30	31	32	33	34	35	36	37	38	39	40

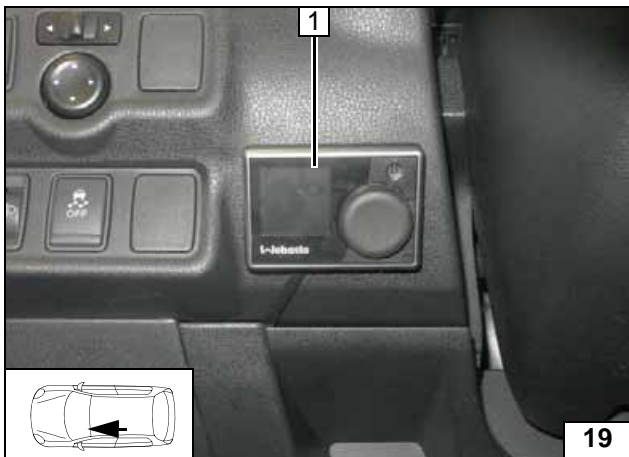

**MultiControl CAR Option**

1 MultiControl CAR



**Installing MultiControl CAR**

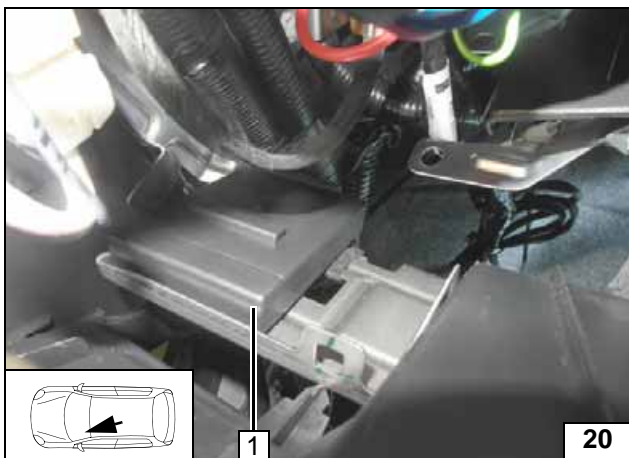

**Remote Option (Telestart)**

Fasten receiver 1 with double-sided adhesive tape.



**Installing receiver**

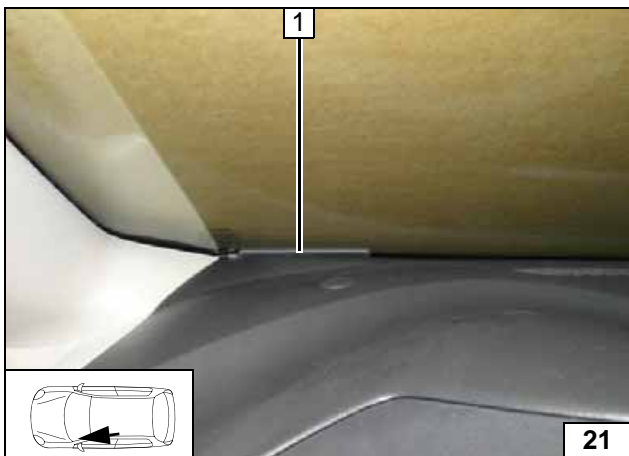

1 Antenna

**Mounting antenna**

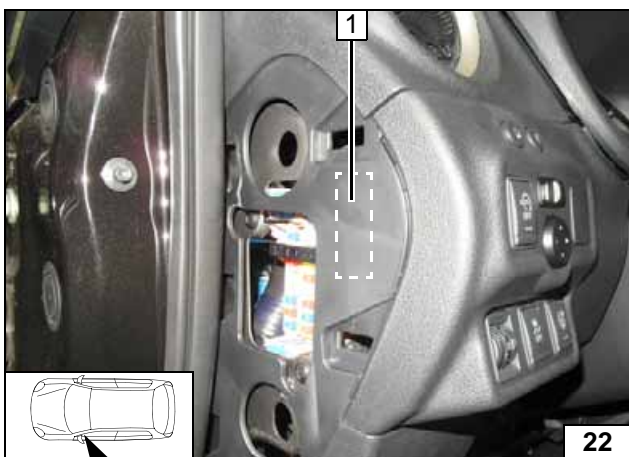

**Temperature sensor T100 HTM**

Secure temperature sensor 1 from behind using double-sided adhesive tape.



**Mounting temperature sensor**

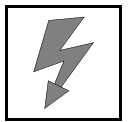

### Remote Option Thermo Call

Fasten receiver 1 with double-sided adhesive tape.

**Installing receiver**

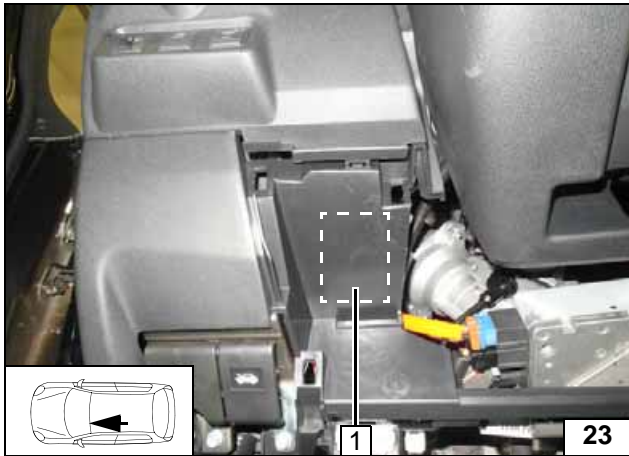

1 Antenna

**Mounting antenna**

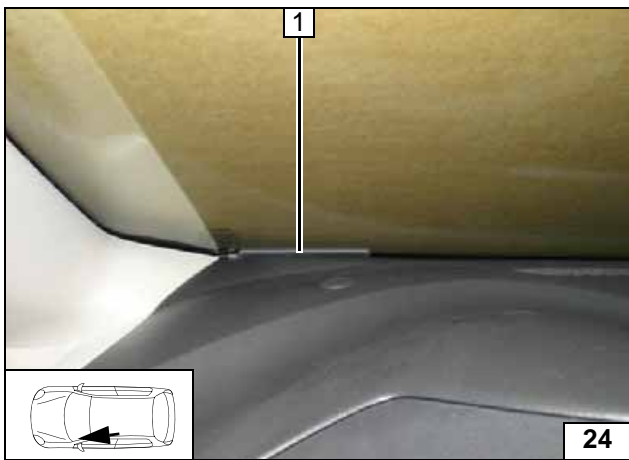

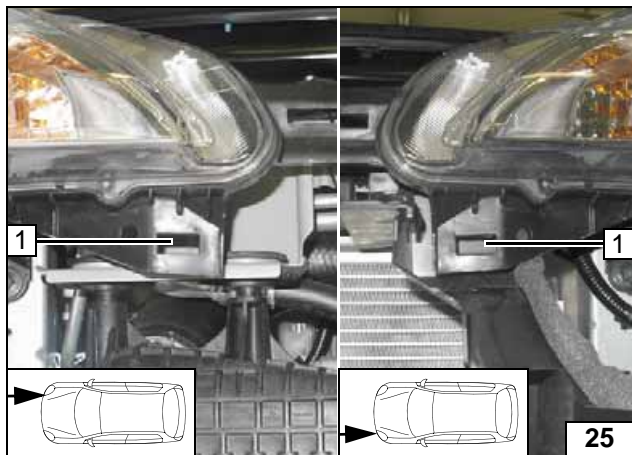

### Radiator Grille Removal Instructions

- 1 Fastening points for retaining clip of radiator grille in left and right headlights.



Removing radiator grille

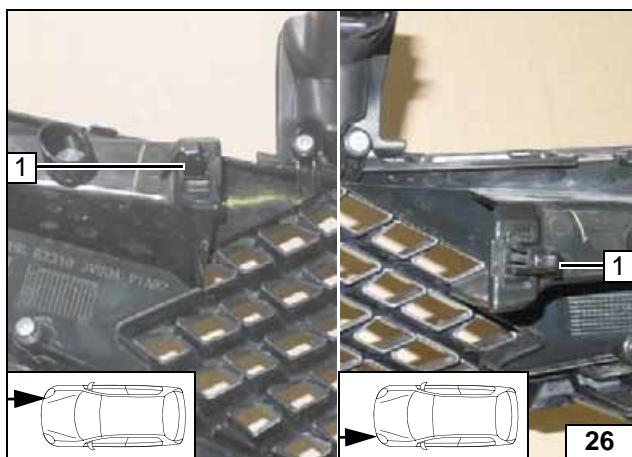

- 1 Retaining clip on the left and the right in radiator grille, inside view

Removing radiator grille

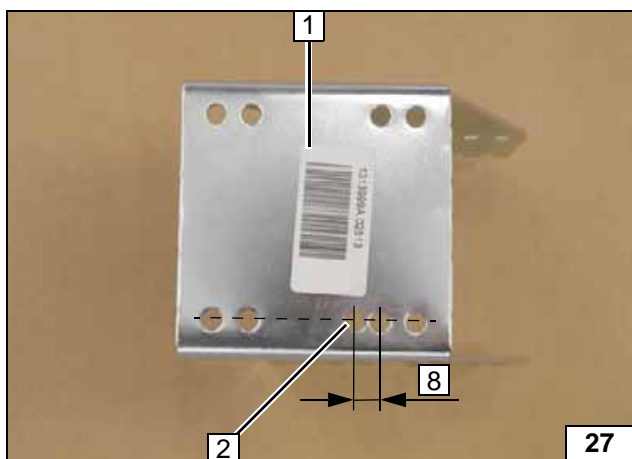

### Mechanical System for Vehicles With SG / With Electrical Auxiliary Heater

#### Preparing Bracket

- 1 Bracket
- 2 7 mm dia. hole

Preparing bracket

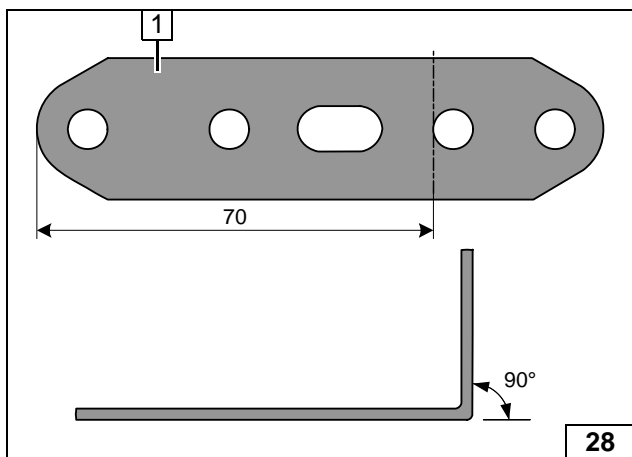

- 1 Perforated bracket



Preparing perforated bracket

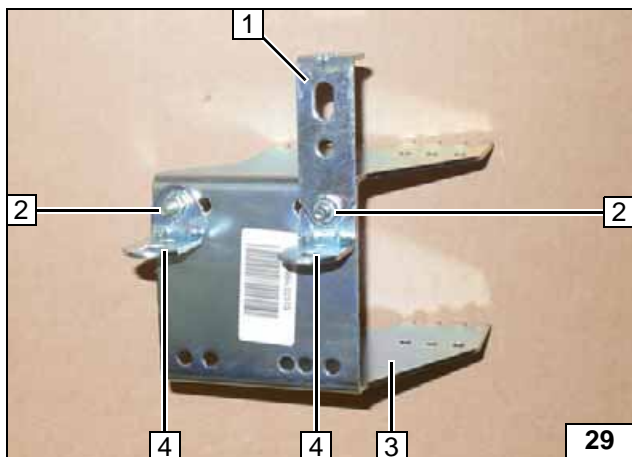

- 1 Perforated bracket
- 2 M6x20 bolt, flanged nut [2x each]
- 3 Bracket
- 4 Angle bracket [2x]

Premounting bracket

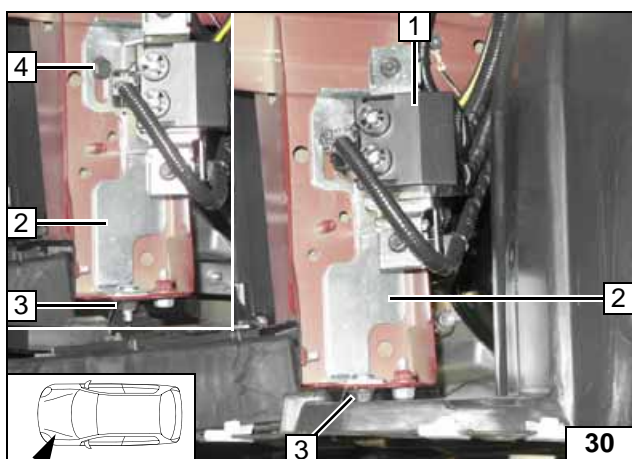

### Preparing Installation Location

59kW / 72kW

Figure shows 59kW!

Remove relay for electrical auxiliary heater 1 with bracket 2. Discard bracket 2. Original vehicle bolt 4 and original vehicle nut 3 will be reused, see "Exhaust for manual transmission" section.



Removing relay

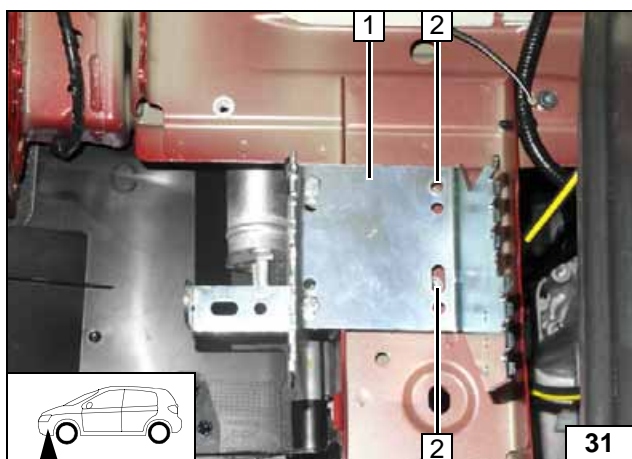

### Installing bracket

Align bracket 1 upwards and place angle bracket on the carrier (see next image).

- 2 Copy hole pattern [2x]



Copying hole pattern

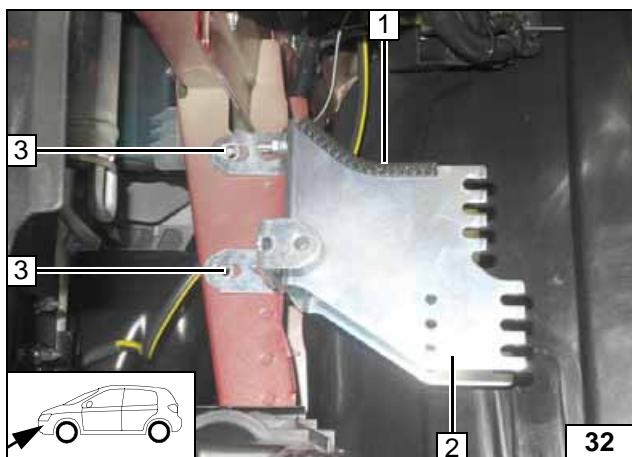

Cut pieces of 1x 100mm and 2x 50mm from provided edge protection!

- 1 100mm edge protection
- 2 Bracket
- 3 Copy hole pattern [2x]



Copying hole pattern

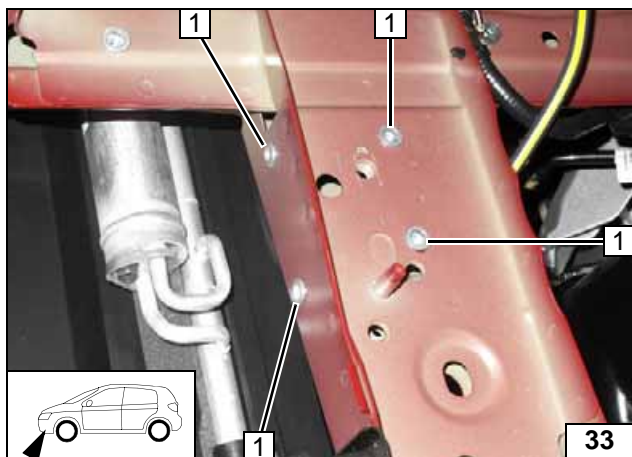

Remove bracket.

- 1 9.1 mm dia. hole; rivet nut [4x each]



Inserting and tightening rivet nuts

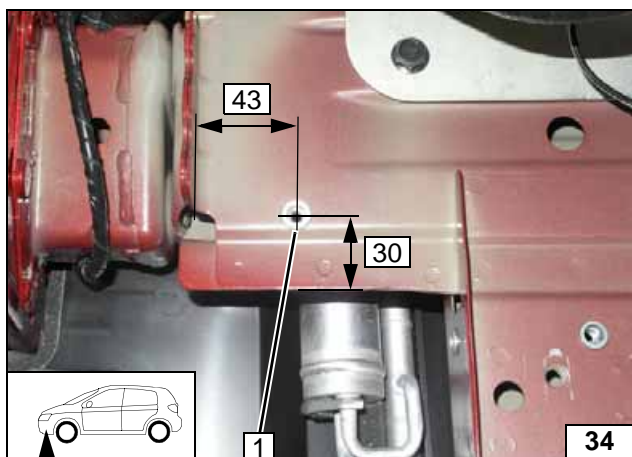

- 1 Drill 9.1 mm dia. hole; rivet nut

Installing rivet nut

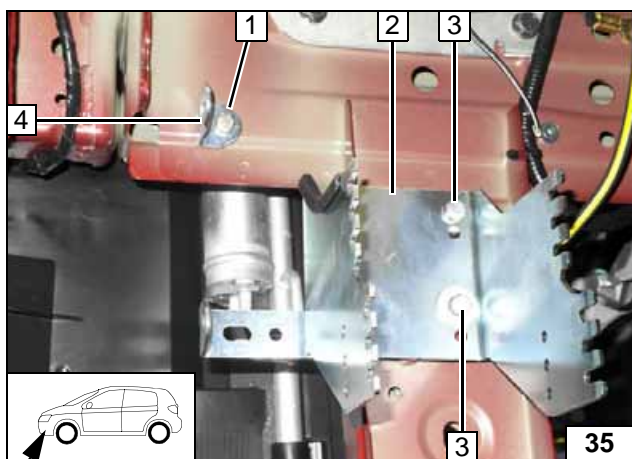

Insert one 20mm shim each between bracket 2 and frame side member at position 3.

- 1 M6x20 bolt, spring lockwasher
- 3 M6x40 bolt, spring lockwasher, 20 mm shim [2x each]
- 4 Angle bracket



Installing bracket

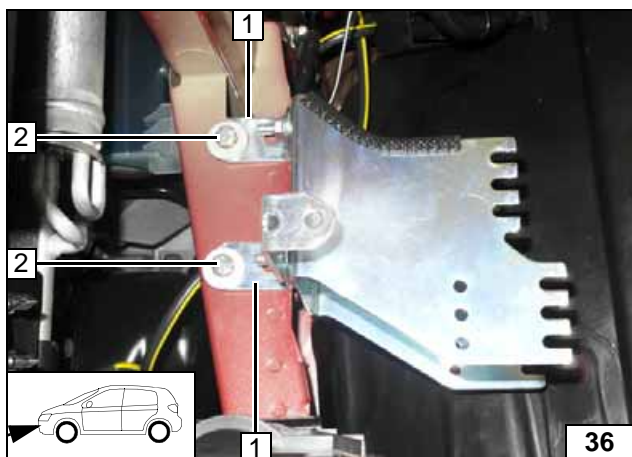

- 1 Angle bracket [2x]
- 2 M6x20 bolt, spring lockwasher, large diameter washer [2x each]

Installing bracket



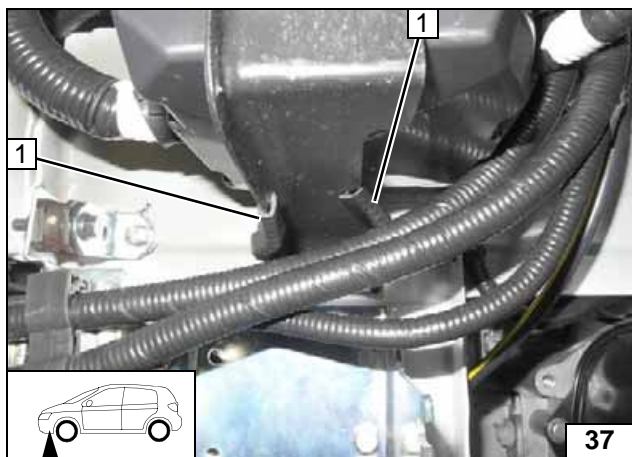

**Only for 72kW**

- 1 50mm edge protection [2x]



**Applying edge protection**

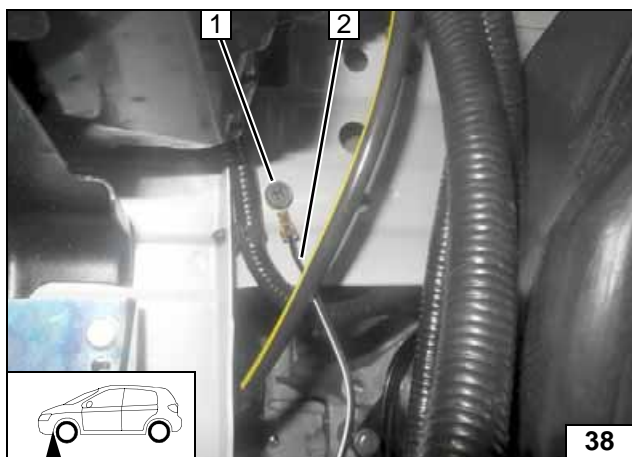

**59kW / 72kW**

Remove original vehicle earth wire **2** (will be connected again later), discard bolt **1**!



**Removing earth wire**

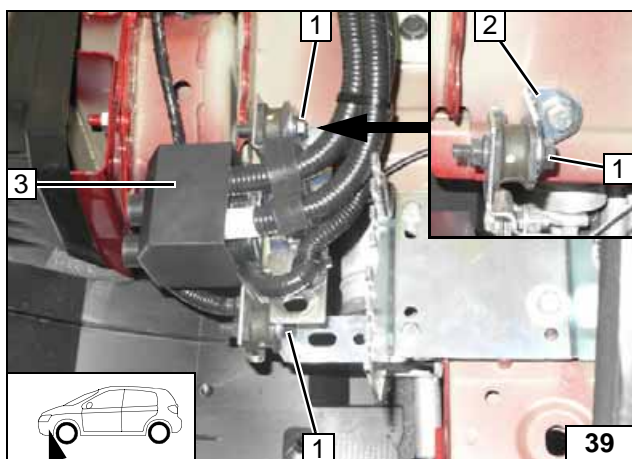

- 1 Original vehicle bolt, flanged nut [2x each]
- 2 Angle bracket
- 3 Relay for electrical auxiliary heater

**Installing relay**

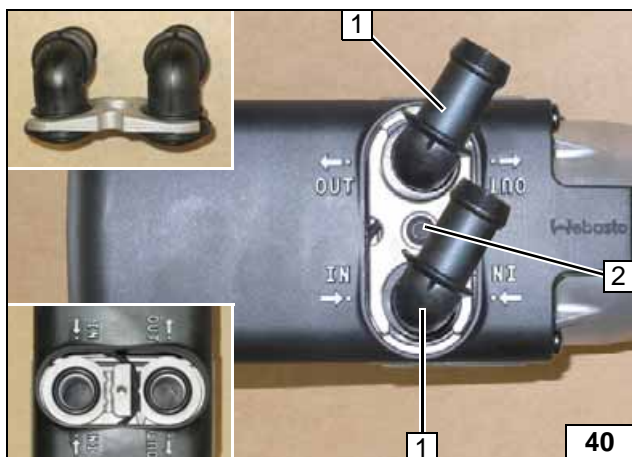

**Preparing Heater**

- 1 Water connection piece, sealing ring [2x each]
- 2 5x15 self-tapping bolt, retaining plate of water connection piece



**Installing water connection piece**

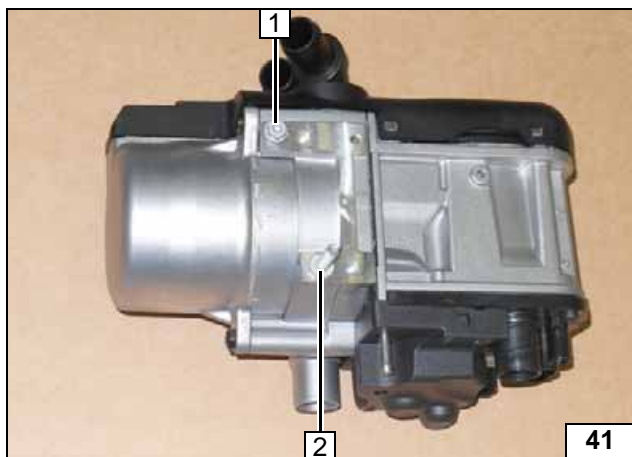
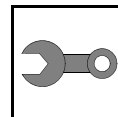

Insert self-tapping bolt 5x13 **1** and stud bolt **2** in the available holes, turning in by max. 3 threads.



Loosely premounting bolts

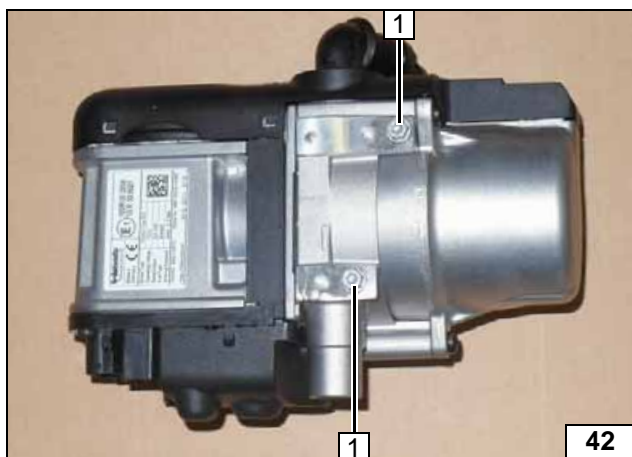

Screw 5x13 self-tapping bolts **1** [2x] into existing holes by a maximum of 3 thread turns.



Loosely premounting bolts

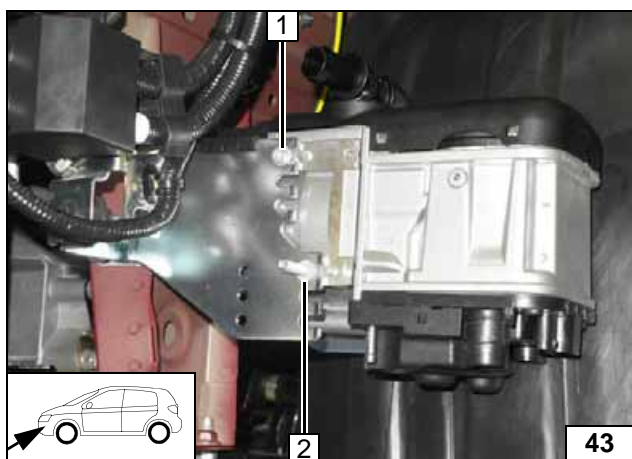

### Installing Heater

- 1 Tighten 5x13 self-tapping bolt
- 2 Tighten stud bolt

Installing heater

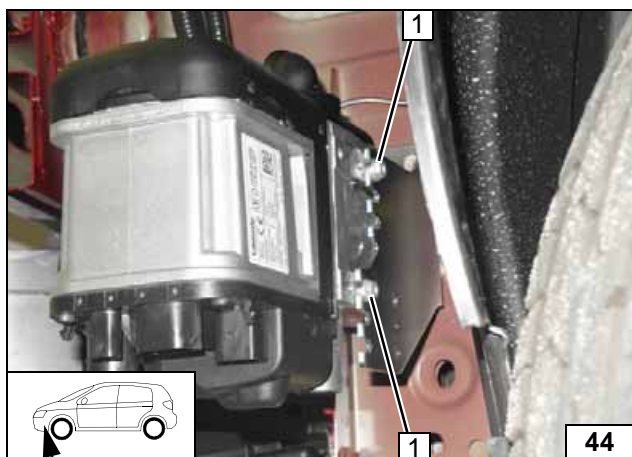

- 1 Tighten 5x13 self-tapping bolt [2x]

Installing heater

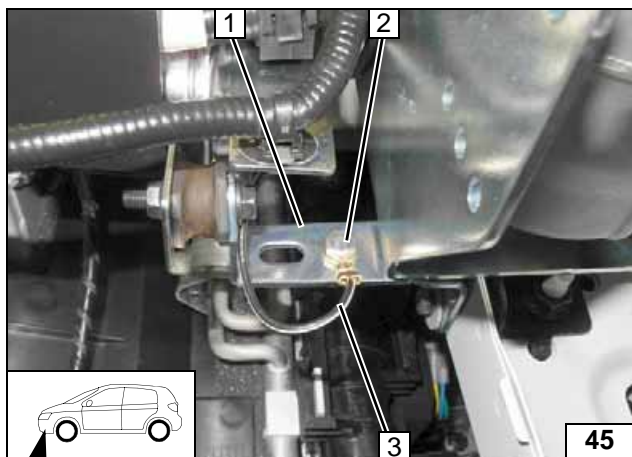
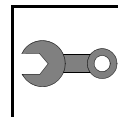

- 1 Perforated bracket (of heater bracket)
- 2 M6x20 bolt, flanged nut
- 3 Original vehicle earth wire

Securing earth wire

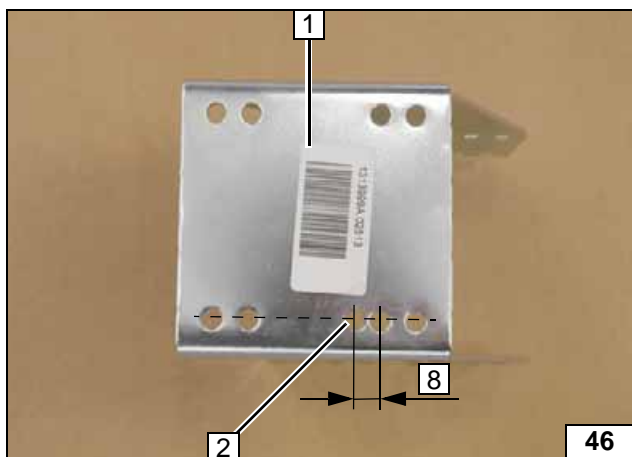

**Mechanical System for Vehicles With SG or AG / Without Electrical Auxiliary Heater**

**Preparing Bracket**

- 1 Bracket
- 2 7 mm dia. hole

Preparing bracket

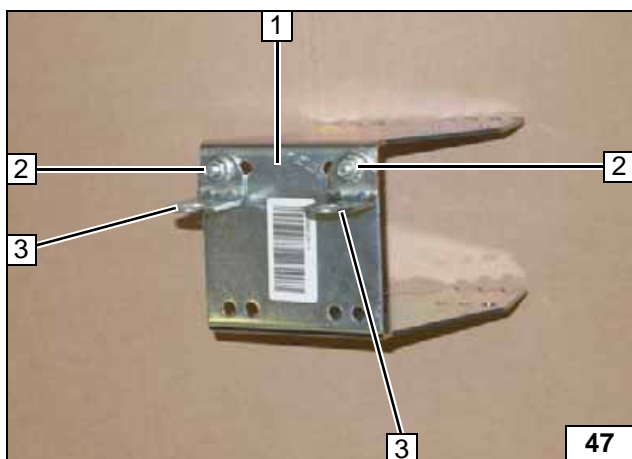

- 1 Bracket
- 2 M6x20 bolt, flanged nut [2x each]
- 3 Angle bracket [2x]

Preparing bracket

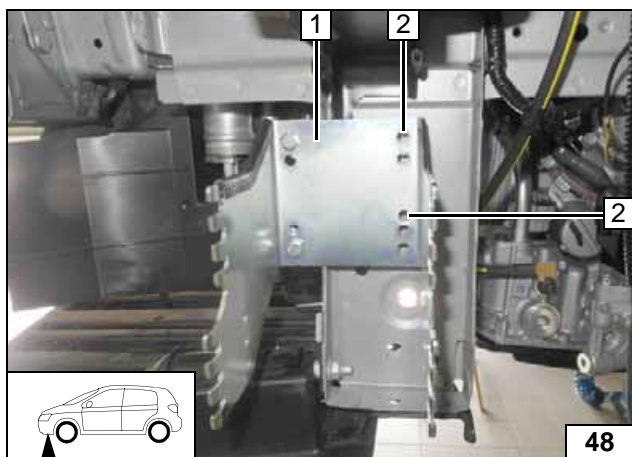

**Installing Bracket**

Align bracket 1 upwards and place angle bracket on the carrier (see next image).

- 2 Copy hole pattern [2x]



Copying hole pattern

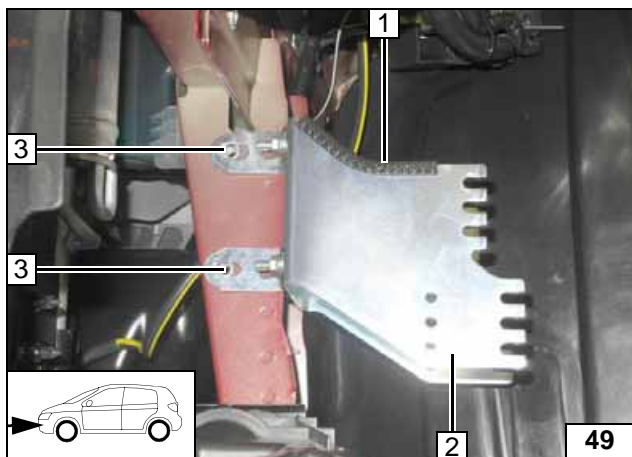

Cut pieces of 1x 100mm and 2x 50mm from provided edge protection!

- 1 100mm edge protection
- 2 Bracket
- 3 Copy hole pattern [2x]



Copying hole pattern

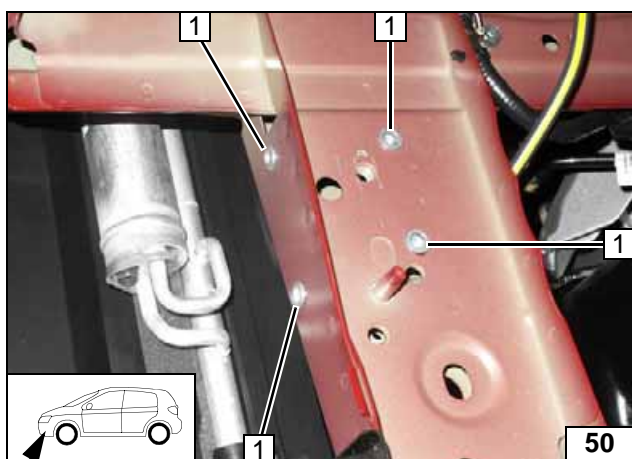

Remove bracket.

- 1 9.1 mm dia. hole; rivet nut [4x each]



Inserting and tightening rivet nuts

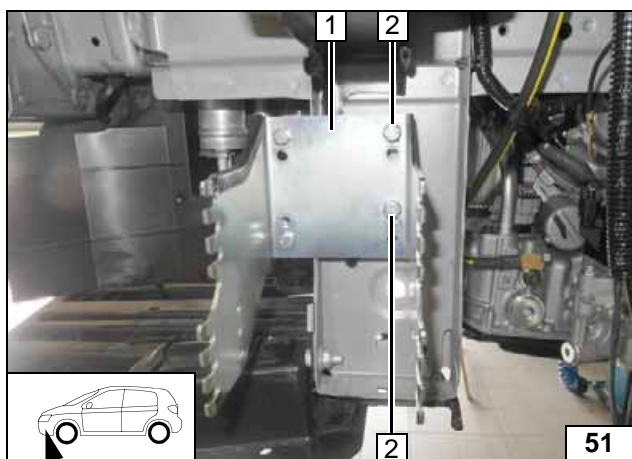

Insert one 20mm shim each between bracket 1 and frame side member at position 2.

- 2 M6x40 bolt, spring lockwasher, 20 mm shim [2x each]



Installing bracket

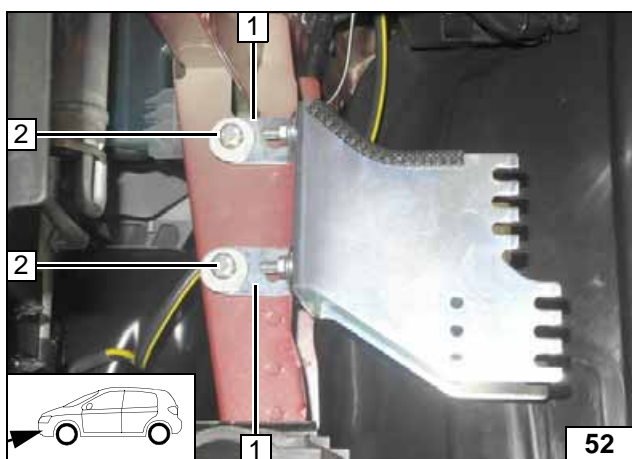

- 1 Angle bracket [2x]
- 2 M6x20 bolt, spring lockwasher, large diameter washer [2x each]

Installing bracket

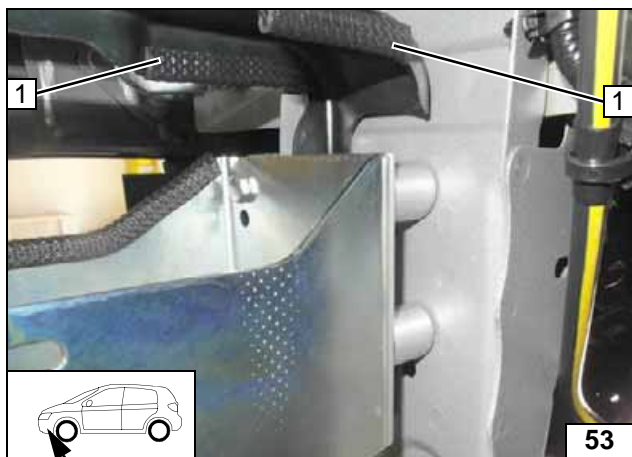

1 50mm edge protection [2x]

Applying edge protection

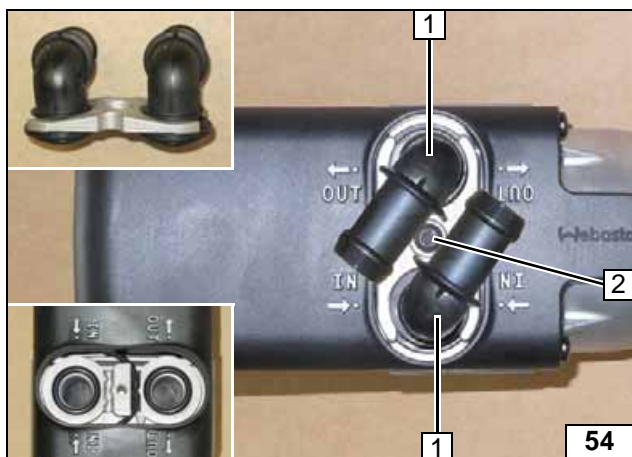

### Preparing Heater

- 1 Water connection piece, sealing ring [2x each]
- 2 5x15 self-tapping bolt, retaining plate of water connection piece



Installing water connection piece

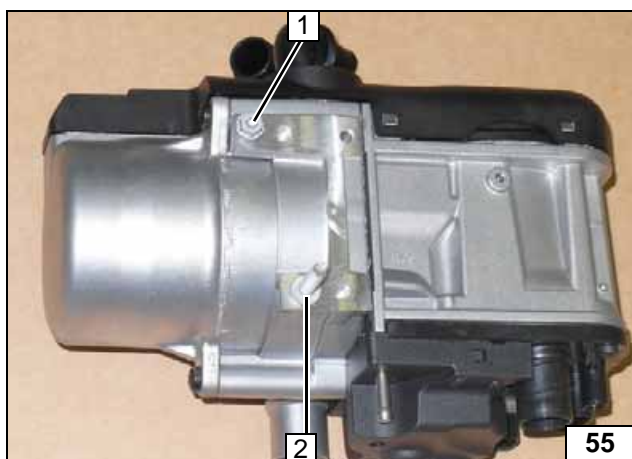

Insert self-tapping bolt 5x13 1 and stud bolt 2 in the available holes, turning in by max. 3 threads.



Loosely pre-mounting bolts



Screw 5x13 self-tapping bolts 1 [2x] into existing holes by a maximum of 3 thread turns.



Loosely pre-mounting bolts

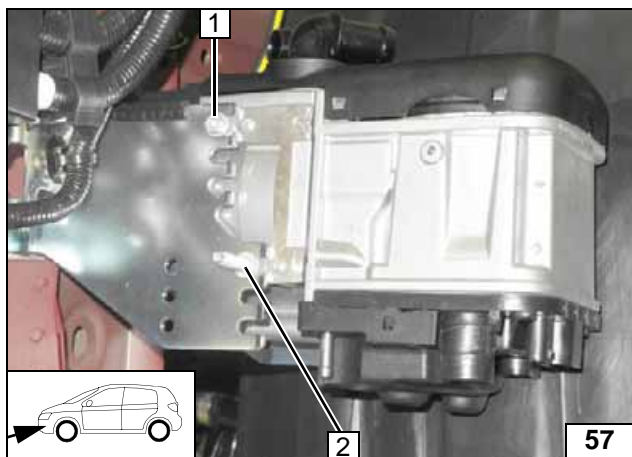

### Installing Heater

- 1 Tighten 5x13 self-tapping bolt
- 2 Tighten stud bolt

Installing heater

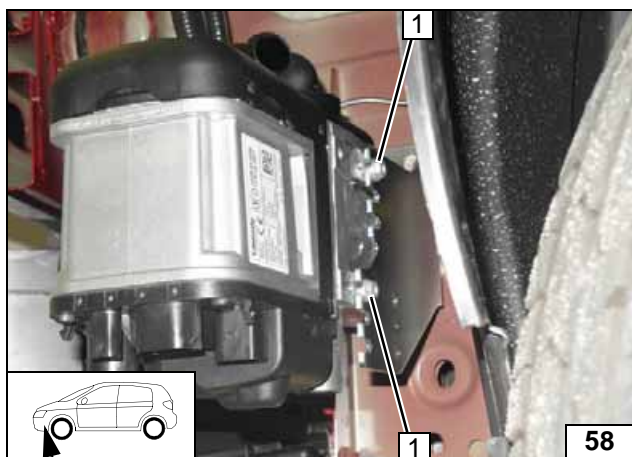

- 1 Tighten 5x13 self-tapping bolt [2x]

Installing heater

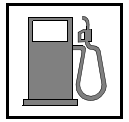

**Fuel for All Vehicles**

**CAUTION!**

Open the vehicle's fuel tank cap, ventilate the tank and then re-close the tank lock.

Catch any fuel running off in an appropriate container.

Route fuel line and metering pump wiring harness so that they are protected against stone impact. Unless specified otherwise, always fasten using cable ties. Provide rub protection for fuel line and wiring harness in areas where there are sharp edges.

**WARNING!**

The fuel line and wiring harness are routed to the metering pump as shown in the wiring harness routing diagram.

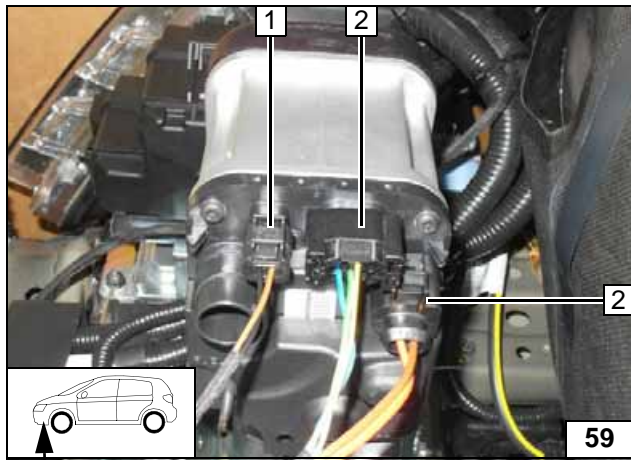

This and all following figures show a vehicle with electrical auxiliary heater!

- 1 Connector of circulating pump wiring harness
- 2 Connector for wiring harness of heater [2x]

**Installing wiring harnesses**

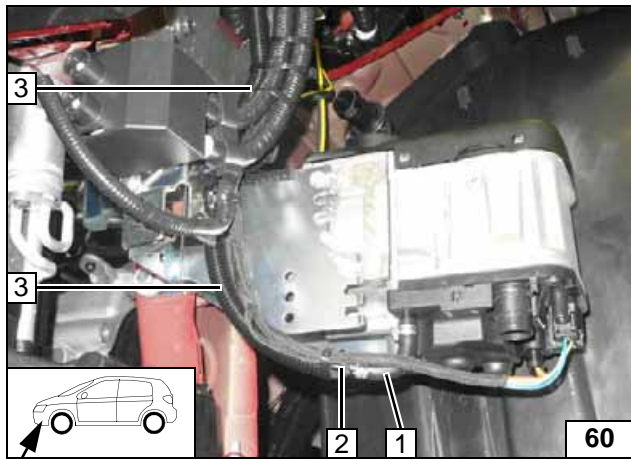

Pull fuel line and wiring harness of metering pump 2 into 10mm dia. corrugated tube 3 and route to the firewall in the engine compartment.

- 1 90° moulded hose, 10 mm dia. clamp [2x]

**Connecting heater**

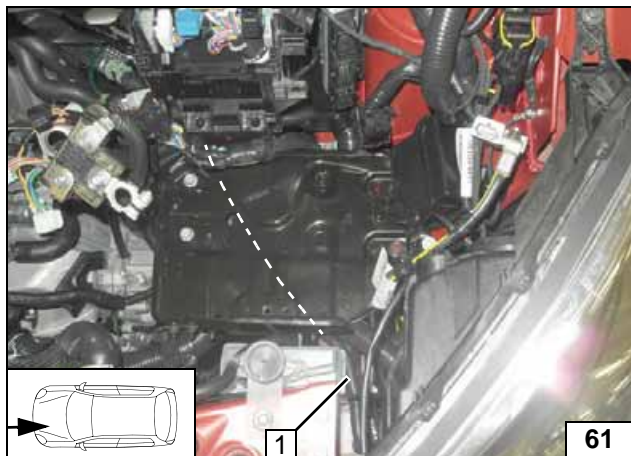

Route fuel line and wiring harness of metering pump in 10mm dia. corrugated tube 1 under battery carrier to firewall.

**Routing lines**

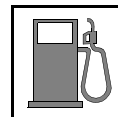

Route fuel line and wiring harness of metering pump in 10 mm dia. corrugated tube **1** along original vehicle fuel lines to underbody.



Routing lines

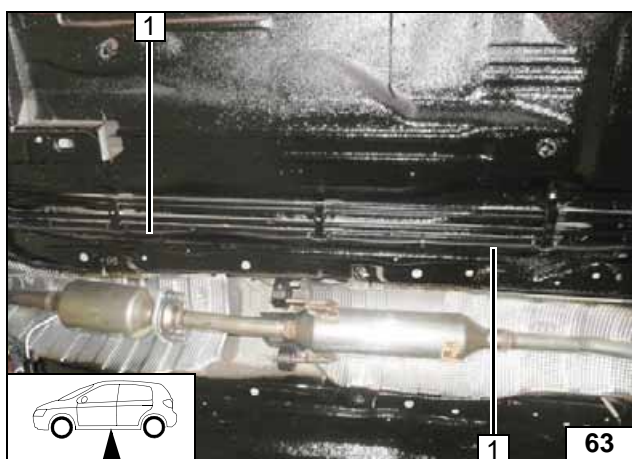

Route fuel line and wiring harness of metering pump in 10mm dia. corrugated tube **1** along original vehicle fuel lines to installation location of metering pump.



Routing lines

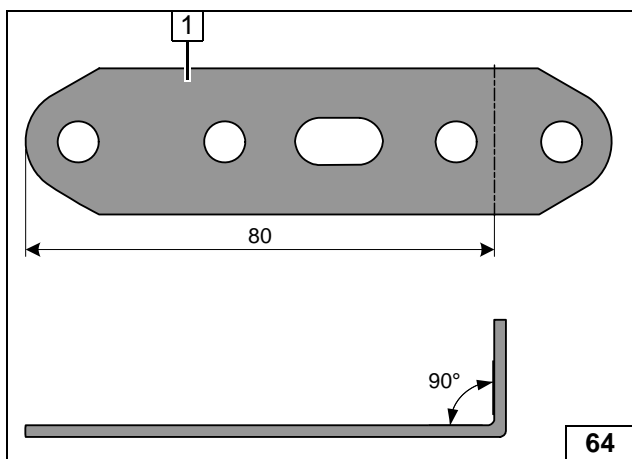

**1** Perforated bracket



Preparing perforated bracket

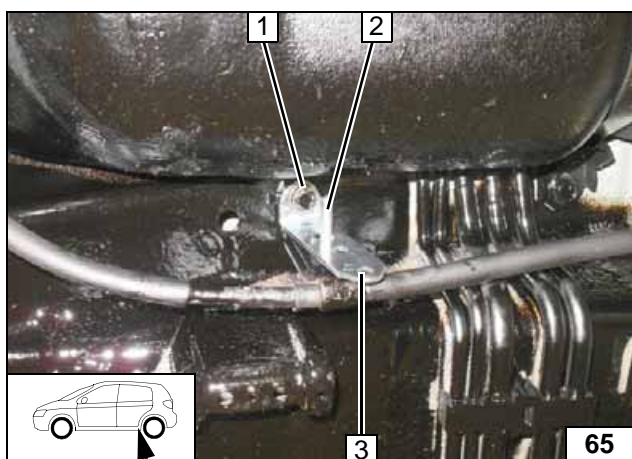

Prior to installation of perforated bracket **3**, insert bolt M6x25 **2** in oblong hole.



**1** Original vehicle bolt from handbrake cable bracket

Installing perforated bracket



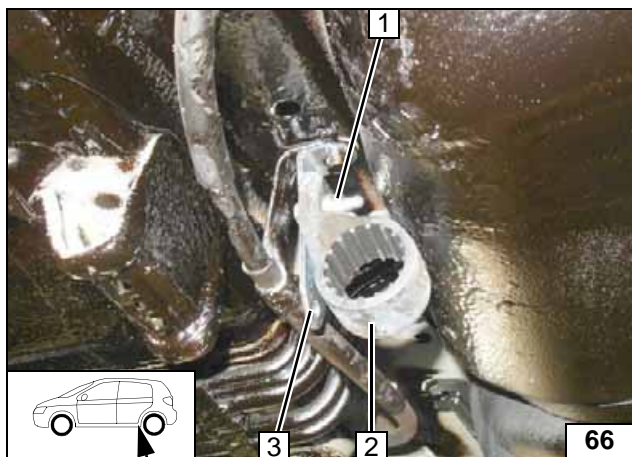

- 1 Support angle bracket, M6 flanged nut
- 2 Metering pump mounting bracket
- 3 Perforated bracket

Installing metering pump mounting bracket

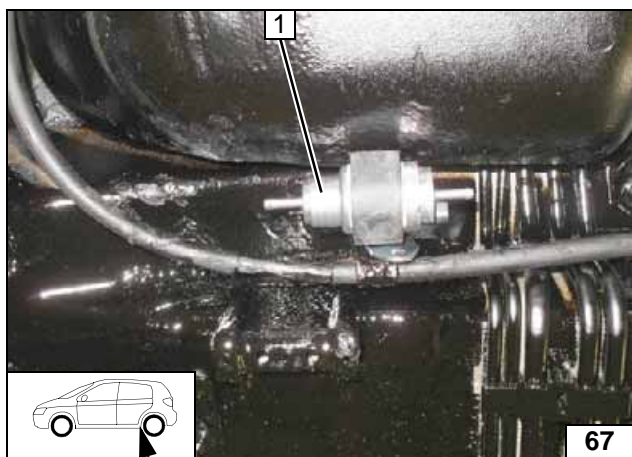

- 1 Metering pump in mounting bracket



Installing metering pump

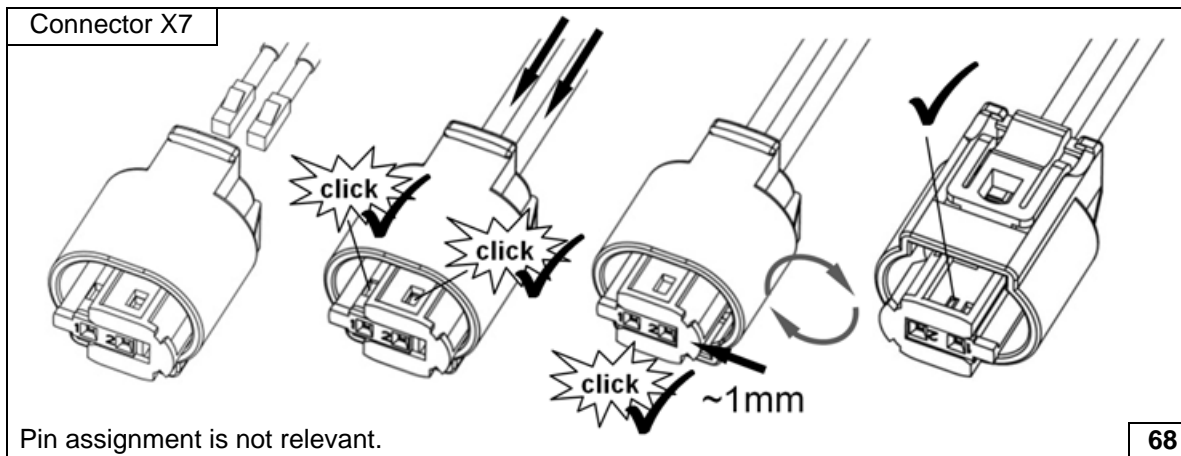

Completing metering pump connector

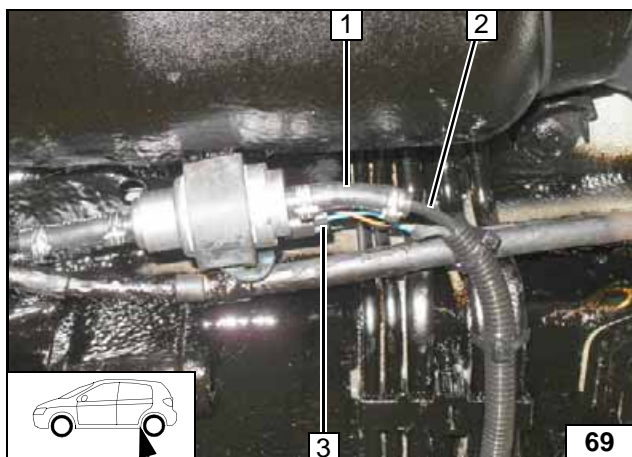

- 1 Hose section, 10 mm dia. clamp [2x]
- 2 Fuel line
- 3 Wiring harness of metering pump, connector X7 mounted



Connecting metering pump

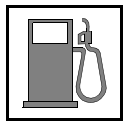

**Fuel extraction**

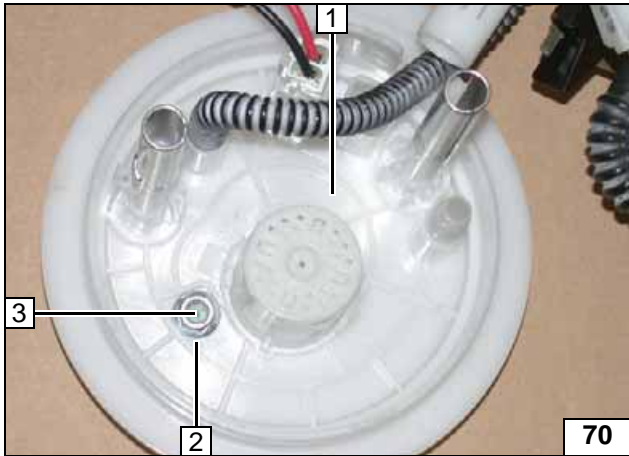

Remove and dismantle fuel-tank sending unit 1 according to manufacturer's instructions.

- 2 Mount M6 flanged nut
- 3 Copy hole pattern, 6 mm dia. hole

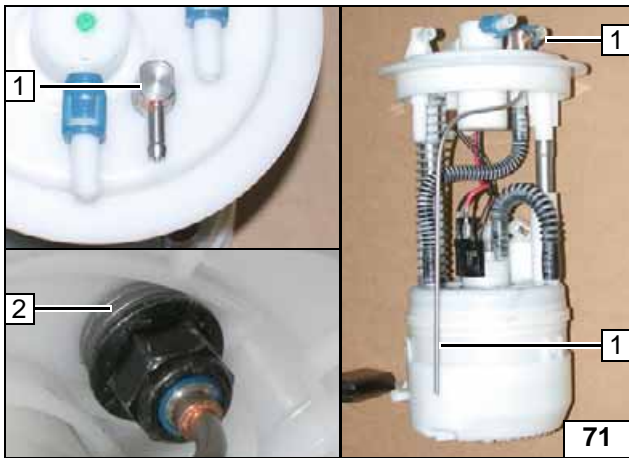

Shape fuel standpipe 1 according to template and cut to length.

- 2 Washer with outer dia.  $d_a = 11.8\text{mm}$  [3x]



**Installing fuel standpipe**

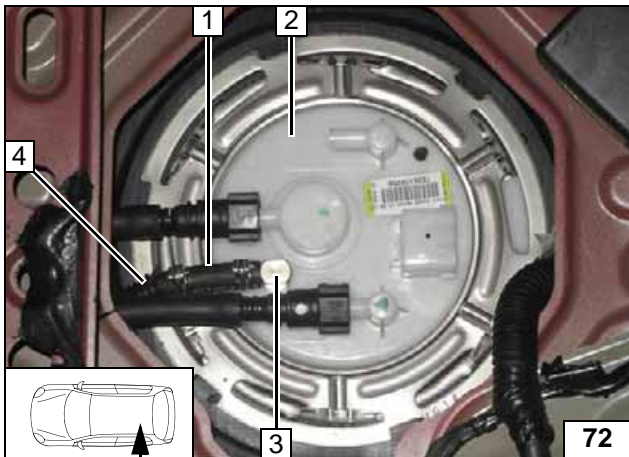

Install fuel-tank sending unit 2 in accordance with manufacturer's instructions.

- 1 Hose section, 10mm dia. clamp [2x]
- 3 Fuel standpipe
- 4 10 mm dia. corrugated tube on fuel line



**Connecting fuel line**

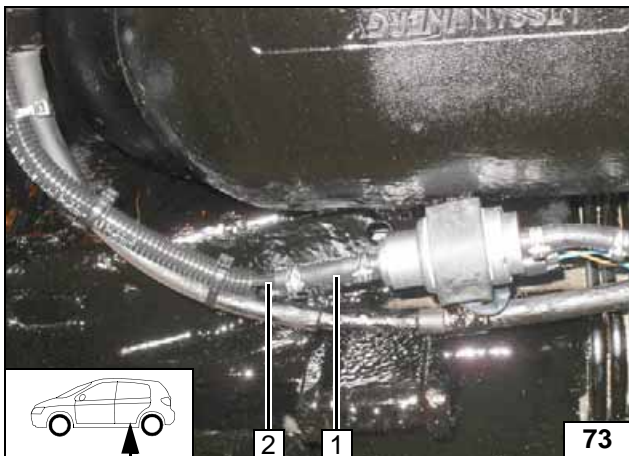

Ensure sufficient distance from neighbouring components and freedom of movement, correct if necessary.

- 1 Hose section, 10 mm dia. clamp [2x]
- 2 Fuel line



**Connecting metering pump**





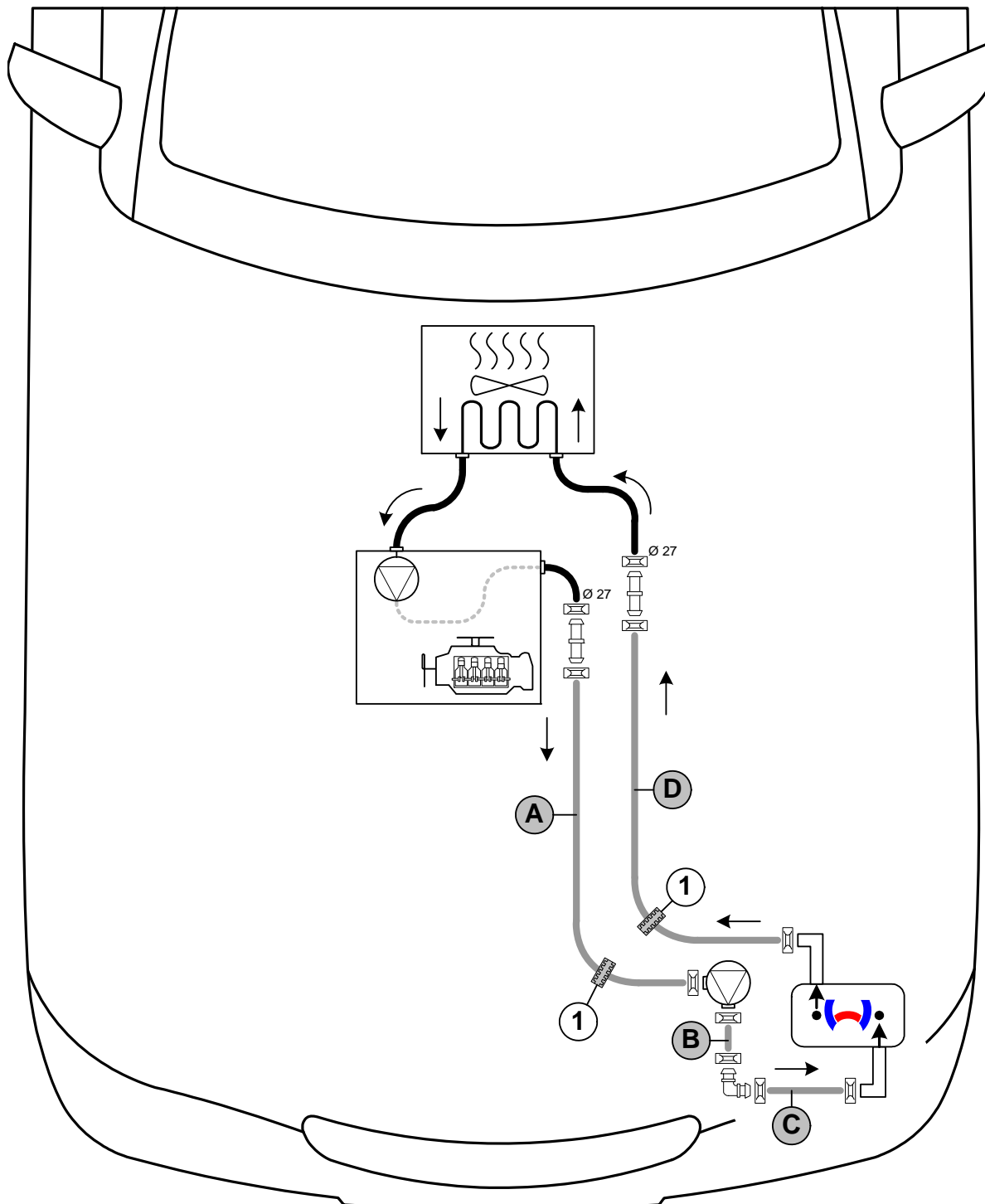

### Coolant circuit of manual transmission

**WARNING!**

Any coolant running off should be collected in an appropriate container. Route hoses so that they are kink-free. Unless specified otherwise, always fasten using cable ties. Position clamps so that no other hoses can be damaged. When installing the hoses, the heater must be filled with coolant. The connection should be modelled on an "inline" circuit and based on the following diagram:



Hose routing diagram

All spring clips without a specific designation  = 25mm dia. 1 = Black (sw) rubber isolator . Connecting pipe  = dia. 18x18 mm! All connecting pipes  = 18x20 mm dia.



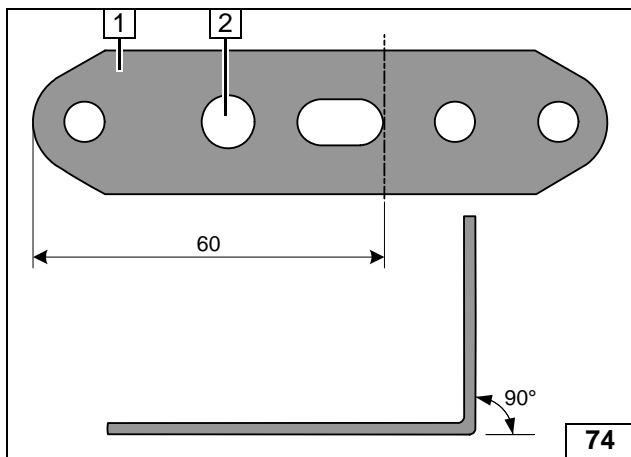

- 1 Perforated bracket
- 2 Drill out hole to 8 mm dia.

Preparing perforated bracket

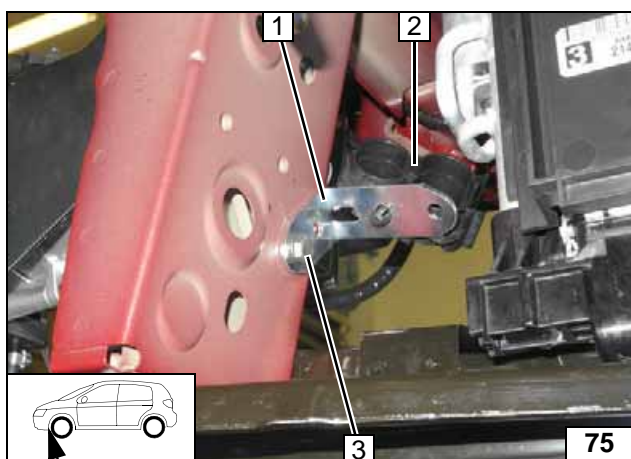

- 1 Perforated bracket
- 2 Insert lockable hose bracket in 8 mm dia. hole
- 3 M6x20 bolt, existing threaded hole

Installing perforated bracket

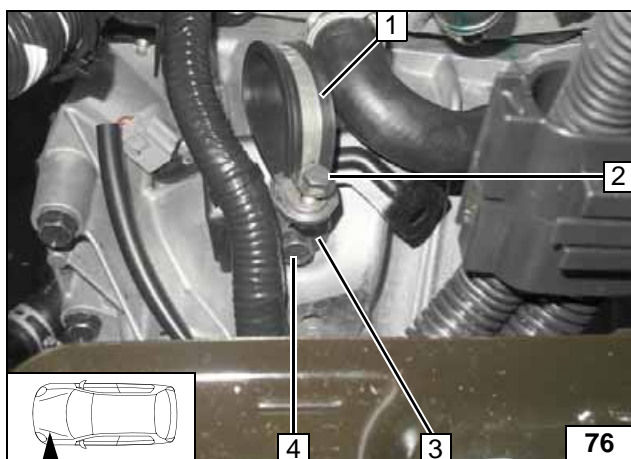

- 1 38 mm dia. rubber-coated p-clamp
- 2 Install M6x20 bolt, flanged nut loosely
- 3 Angle bracket
- 4 Original vehicle bolt

Mounting rubber-coated p-clamp loosely

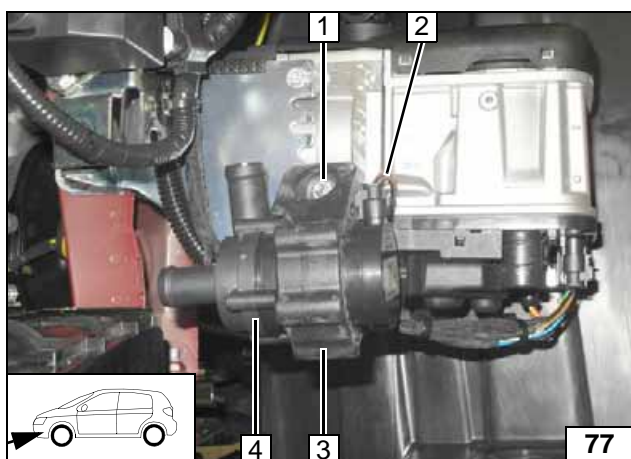

- 1 M6 flanged nut on stud bolt
- 2 Wiring harness of circulating pump
- 3 Circulating pump mounting bracket
- 4 Circulating pump

Installing circulating pump

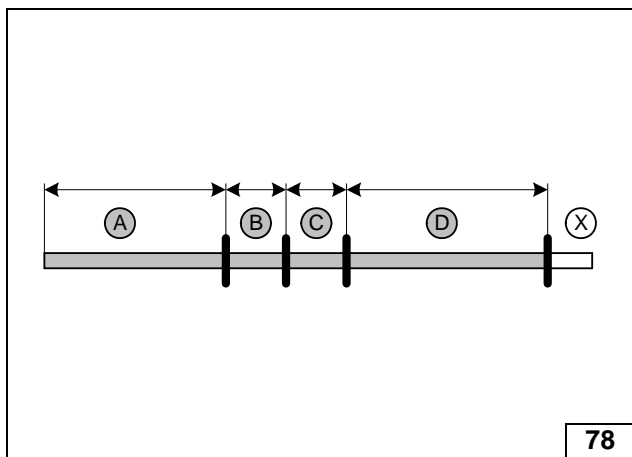
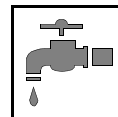

Discard section X.

	59 kW	72 kW
A =	720	820
B =	110	110
C =	80	80
D =	720	820



Cutting hoses to length

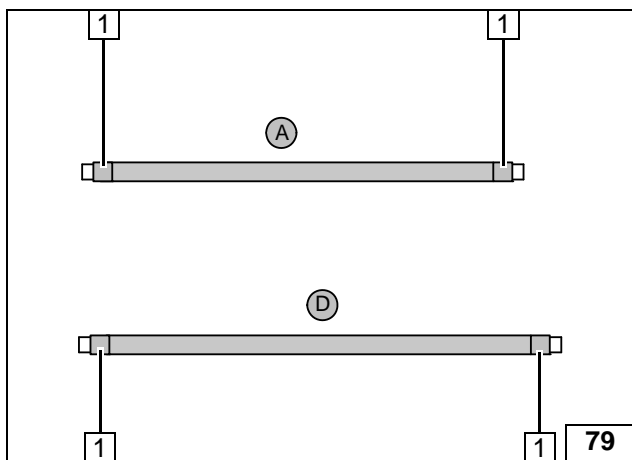

Push braided protection hoses onto hose A and D and cut to length. Cut heat shrink plastic tubing to length.



- 1 50 mm long heat shrink plastic tubing [4x]

Preparing hoses

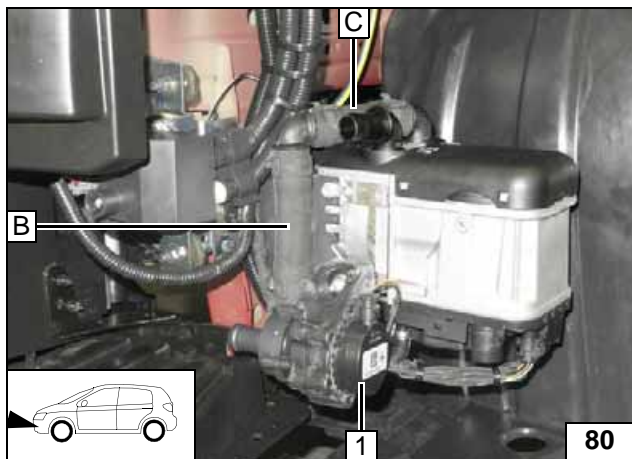

- 1 Circulating pump

Connecting heater inlet / circulating pump

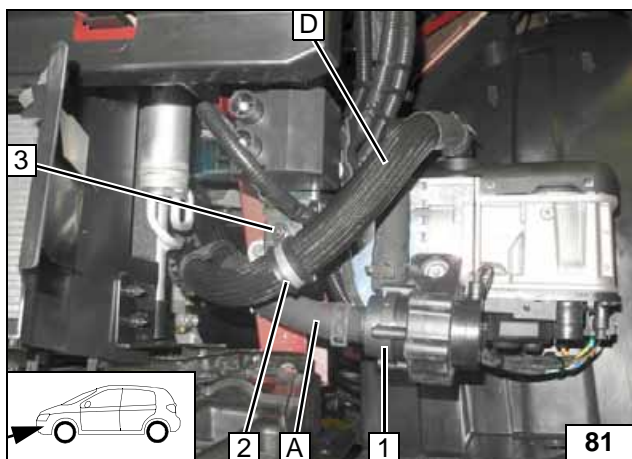

- 1 Circulating pump
- 2 25 mm dia. rubber-coated p-clamp
- 3 Original vehicle bolt

Connecting heater outlet

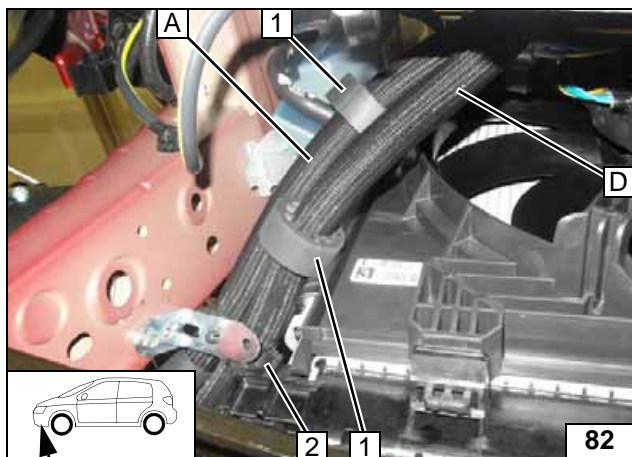

Slide one black (sw) rubber isolator 1 [2x] onto hose A and hose D. Route hose A and hose D through hose bracket 2. Lock hose bracket 2.

- 1 Black (sw) rubber isolator [2x]
- 2 Hose bracket



**Routing in engine compartment**

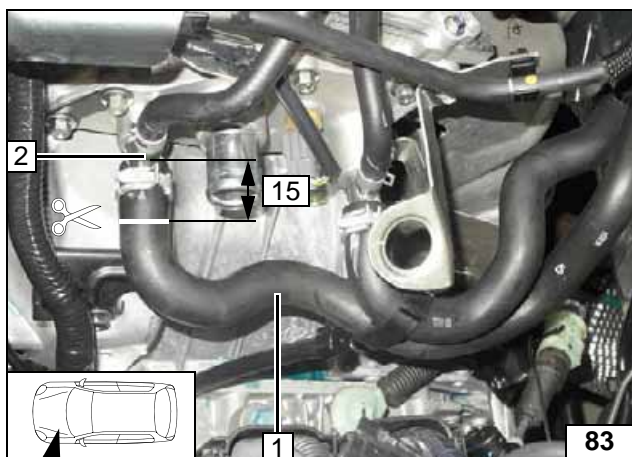

59 kW

Disconnect engine inlet / heat exchanger outlet hose 1 at engine inlet connection piece, shorten by 15mm and reinstall.



**Shortening hose on engine inlet**

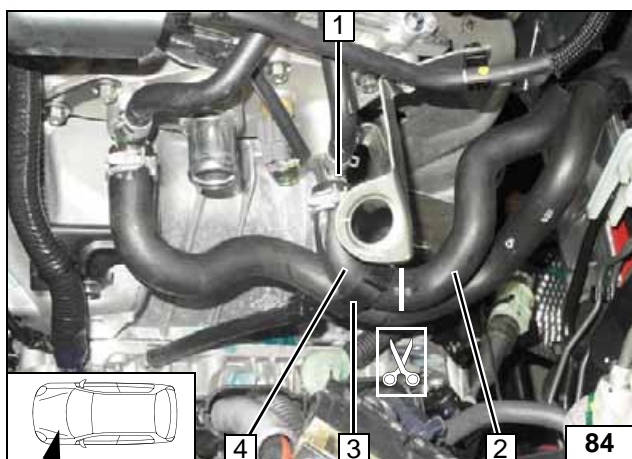

Remove original vehicle hose bracket 3, will be reused. Turn engine outlet hose section 4 on engine outlet connection piece 1 to the front.

- 2 Hose section of heat exchanger inlet



**Cutting point**

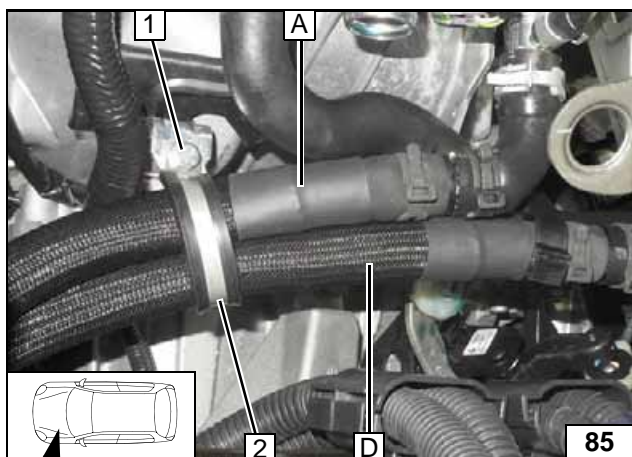

Route hoses A and D through rubber-coated p-clamp 2.

- 1 Install M6x20 bolt loosely



**Routing in engine compartment**

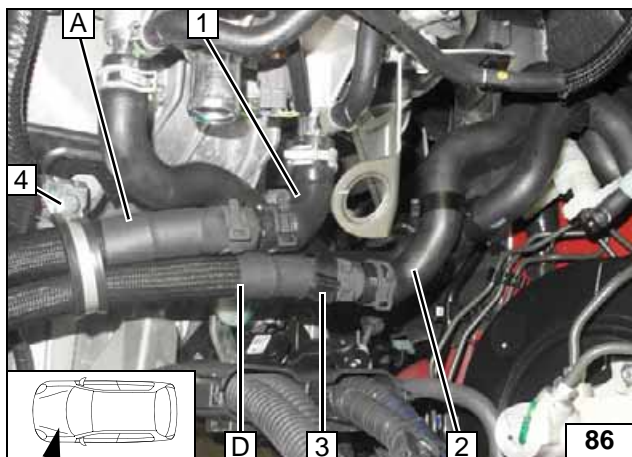

Align hose and tighten bolt **4!**

- 1 Hose on engine outlet turned
- 2 Hose on heat exchanger inlet
- 3 Hose bracket installed



**Connection of engine outlet / heat exchanger inlet**

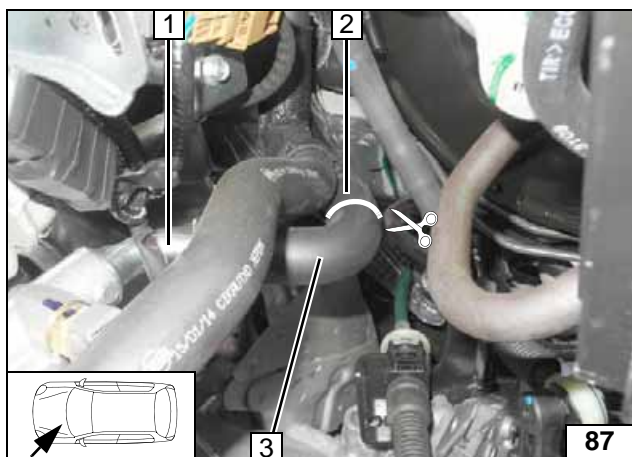

**72 kW**

Cut engine outlet / heat exchanger inlet hose at the marking. Turn engine outlet hose section **3** on engine outlet connection piece **1** by 180°.

- 2 Hose section of heat exchanger inlet



**Cutting point**

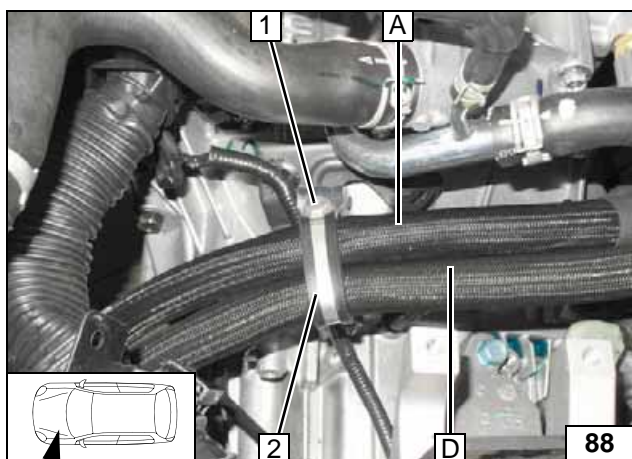

Route hoses **A** and **D** through rubber-coated p-clamp **2**.

- 1 Install M6x20 bolt loosely



**Routing in engine compartment**

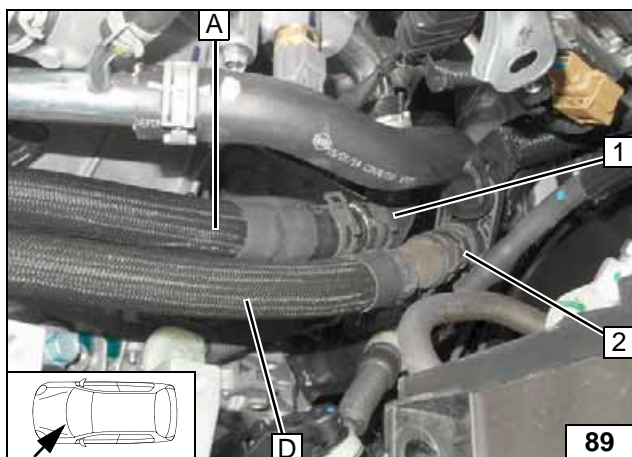

- 1 Hose section of engine outlet turned
- 2 Hose section of heat exchanger inlet



**Routing in engine compartment**

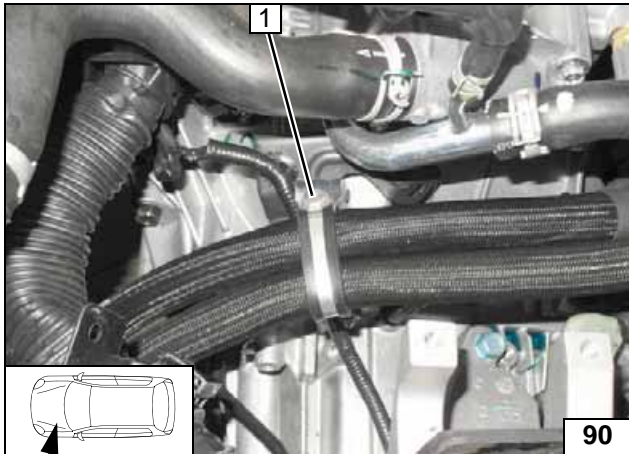

Align hose and tighten bolt 1!



Aligning hoses

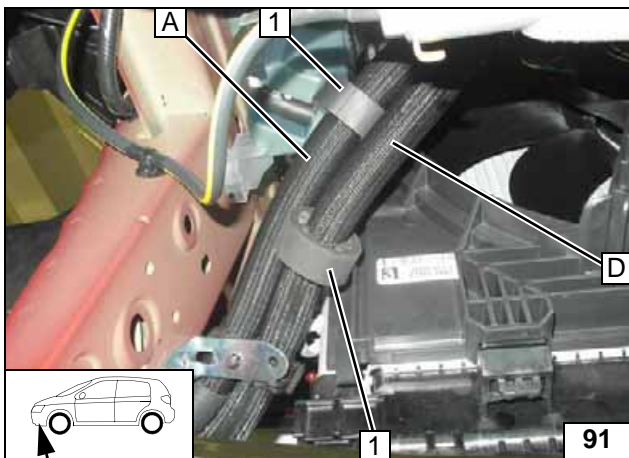

59kW / 72kW

Align black (sw) rubber isolator 1 [2x] onto hoses **A** and **D** with fan housing. Ensure sufficient distance from neighbouring components, correct if necessary.



Aligning hoses



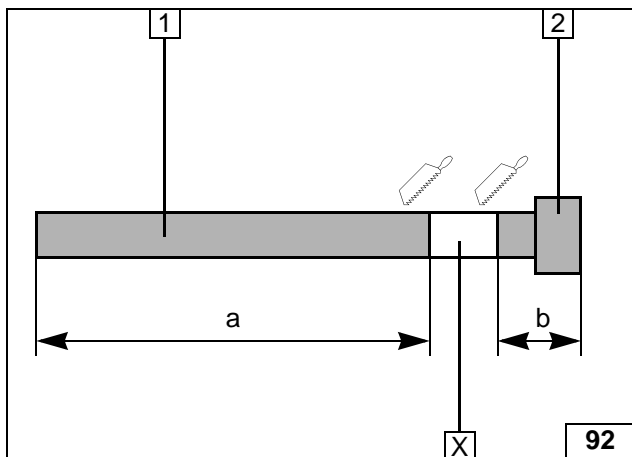
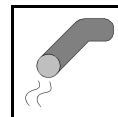

### Exhaust for Manual Transmission

Discard section X.

- 1 Exhaust pipe  
a = 460
- 2 Exhaust end section  
b = 70

Preparing exhaust pipe

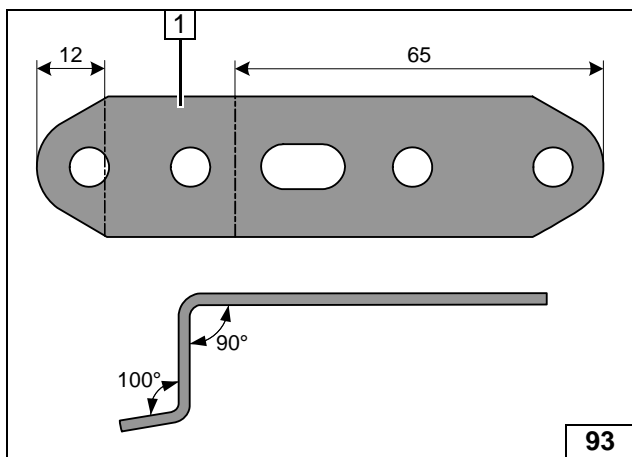

- 1 Perforated bracket

Preparing perforated bracket

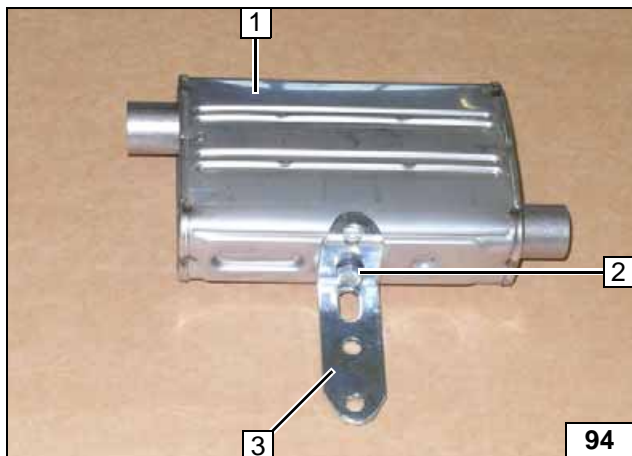

- 1 Silencer
- 2 M6x16 bolt, spring lockwasher
- 3 Perforated bracket

Preparing silencer

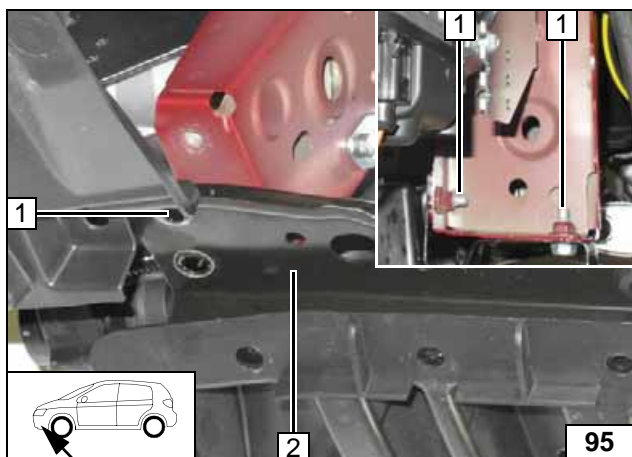

Detach cross member 2 on the left. M8 bolts 1 [2x] will be reused.

Detaching cross member

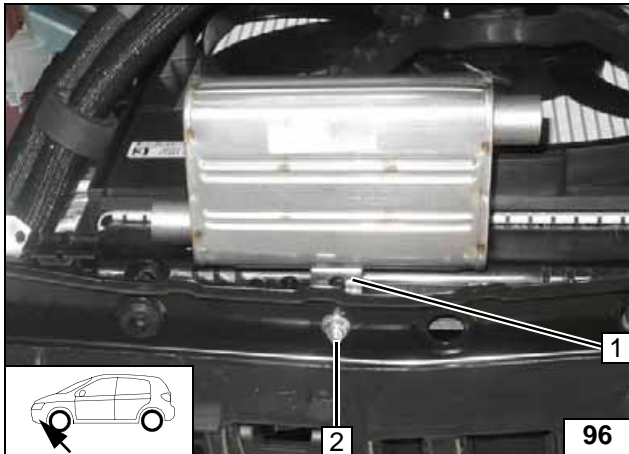
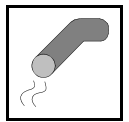

- 1 Perforated bracket
- 2 M6x20 bolt, flanged nut, existing hole

**Mounting  
silencer**

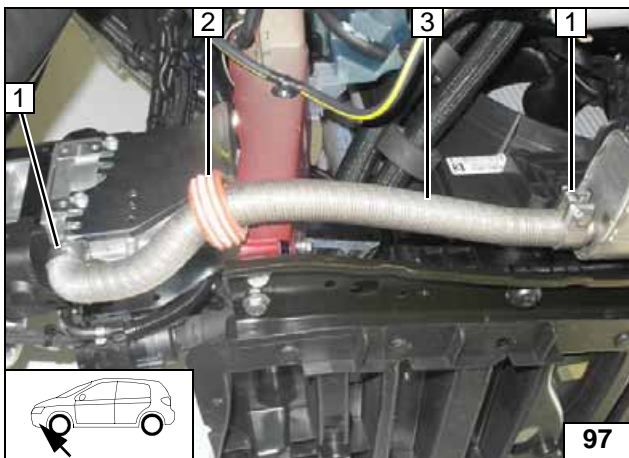

- 1 Hose clamp [2x]
- 2 Slide on spacer bracket and align
- 3 Exhaust pipe

**Mounting  
exhaust  
pipe**

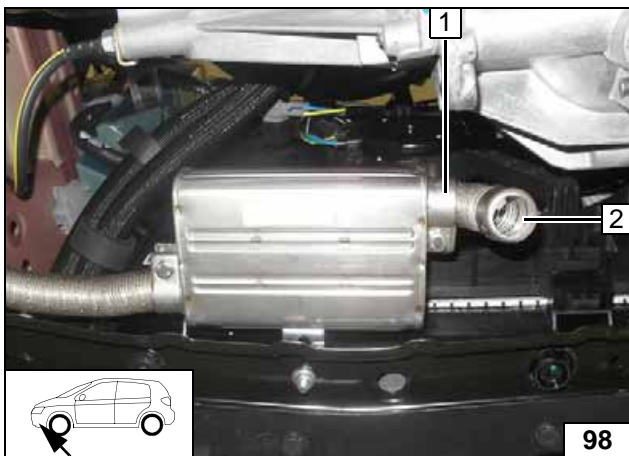

- 1 Hose clamp
- 2 Exhaust end section

**Mounting  
exhaust  
end section**





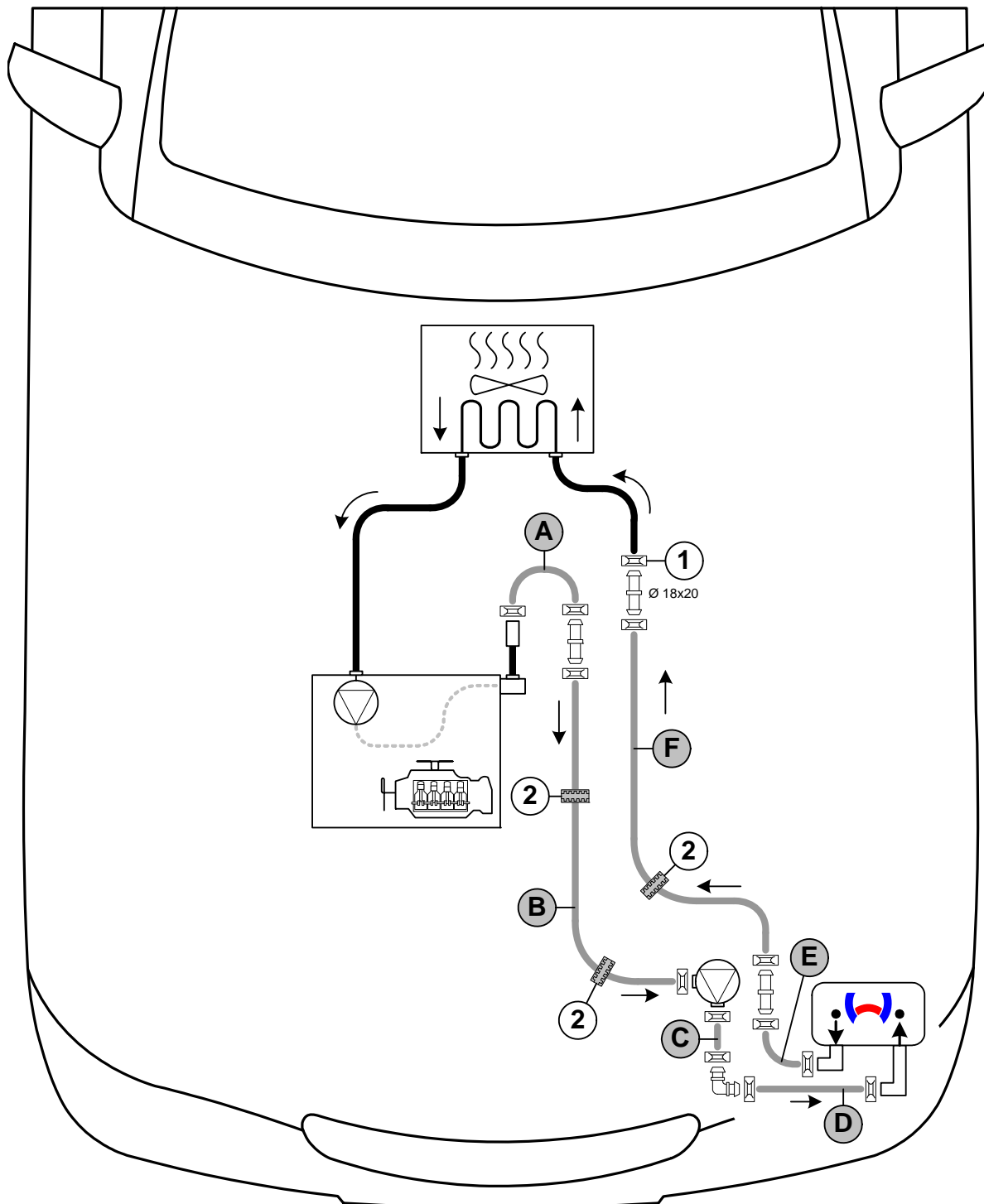

### Coolant Circuit for Automatic Transmission

**WARNING!**

Any coolant running off should be collected in an appropriate container. Route hoses so that they are kink-free. Unless specified otherwise, always fasten using cable ties. Position clamps so that no other hoses can be damaged. When installing the hoses, the heater must be filled with coolant. The connection should be modelled on an "inline" circuit and based on the following diagram:



Hose routing diagram

All spring clips without a specific designation  = 25mm dia. 1 = Original vehicle spring clip . 2 = Black (sw) rubber isolator . All connecting pipes without a specific designation  and  = 18x18mm dia.



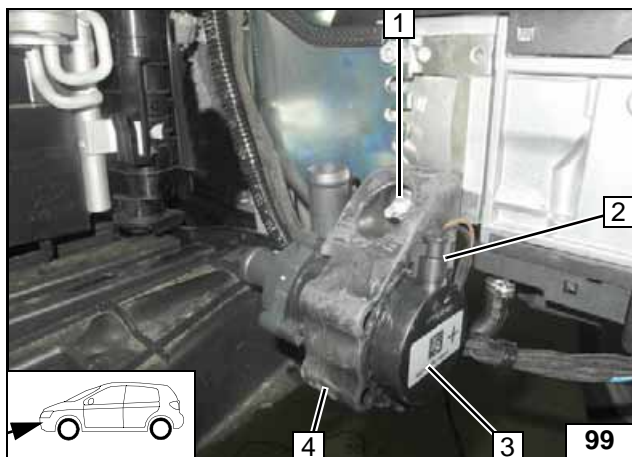

- 1 M6 flanged nut on stud bolt
- 2 Connector of circulating pump wiring harness
- 3 Circulating pump
- 4 Circulating pump mounting bracket

Installing circulating pump

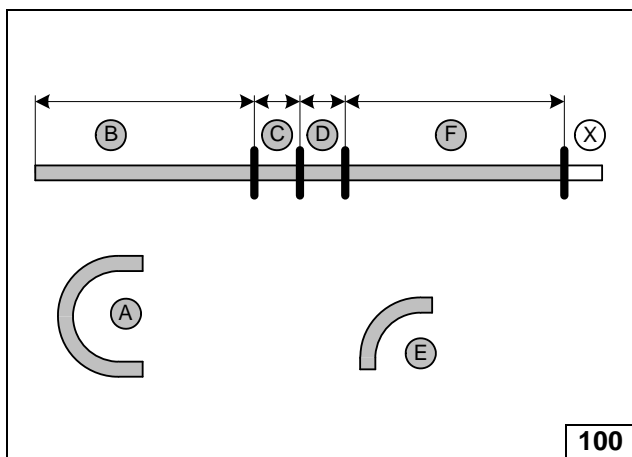

Discard section X.  
 Hose A = 180°, 18mm dia. moulded hose  
 Hose E = 90°, 18 mm dia. moulded hose

- B = 915
- C = 110
- D = 80
- F = 865



Cutting hoses to length

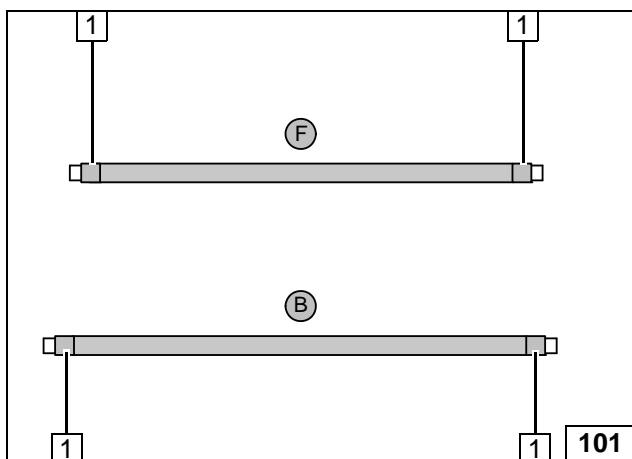

Slide braided protection hoses onto hoses B and F and cut to length. Cut heat shrink plastic tubing to length.

- 1 50 mm long heat shrink plastic tubing [4x]



Preparing hoses

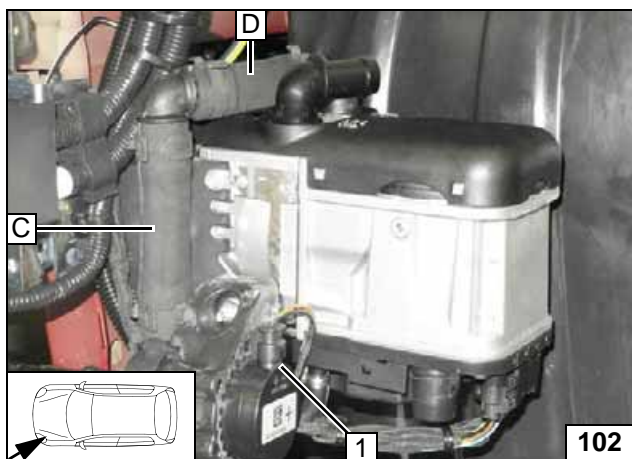

- 1 Circulating pump

Connecting heater inlet / circulating pump

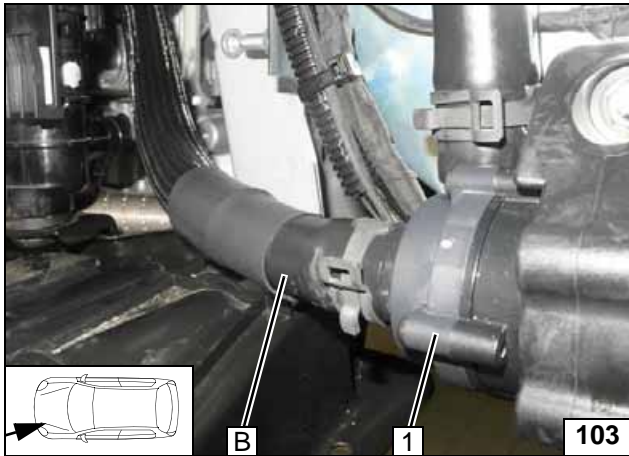

1 Circulating pump

Connect-  
ing circu-  
lating  
pump

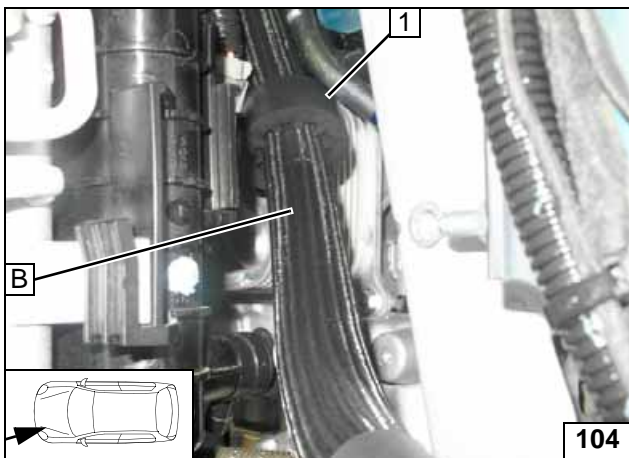

1 Slide on black (sw) rubber isolator

Routing in  
engine  
compart-  
ment

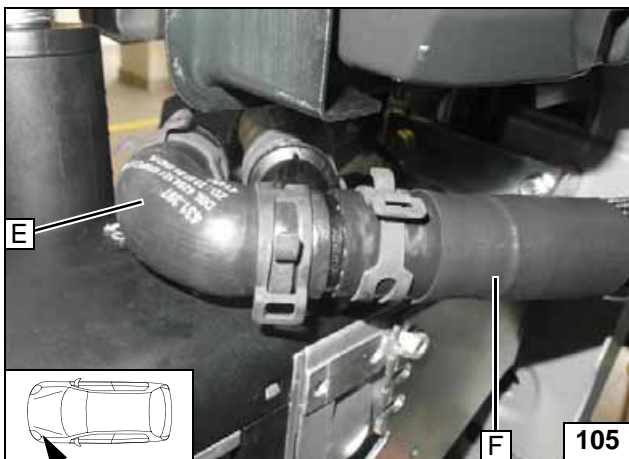

Connect-  
ing heater  
outlet

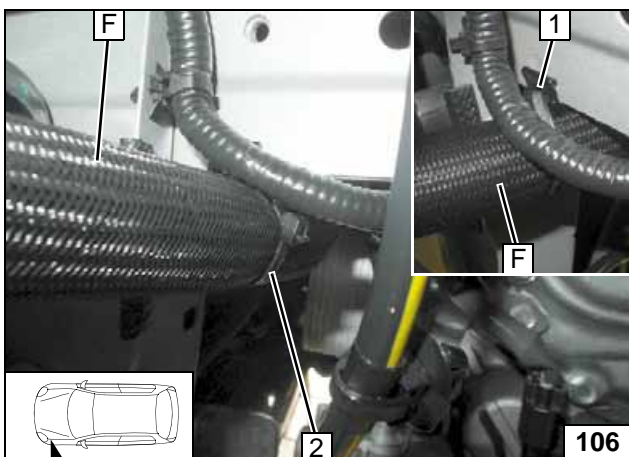

Install fastening clip 1 on the bottom edge of the frame side member!



2 Close cable tie

Routing in  
engine  
compart-  
ment

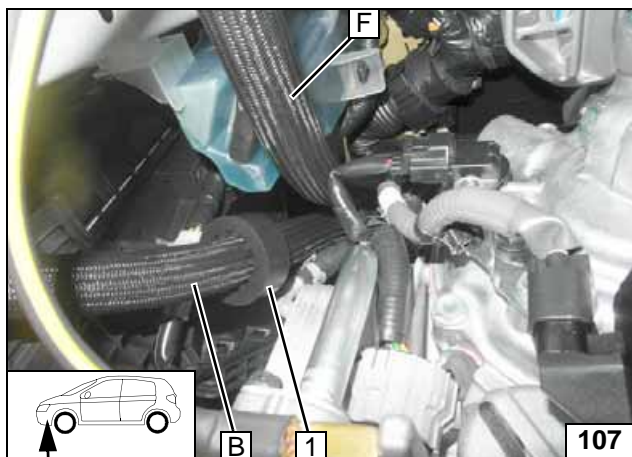

Align black (sw) rubber isolator **1** as shown!



Routing in engine compartment

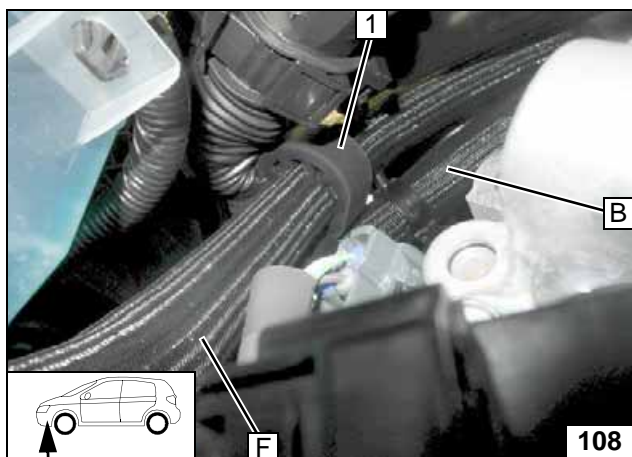

Slide black (sw) rubber isolator **1** onto hose **F**.



Routing in engine compartment

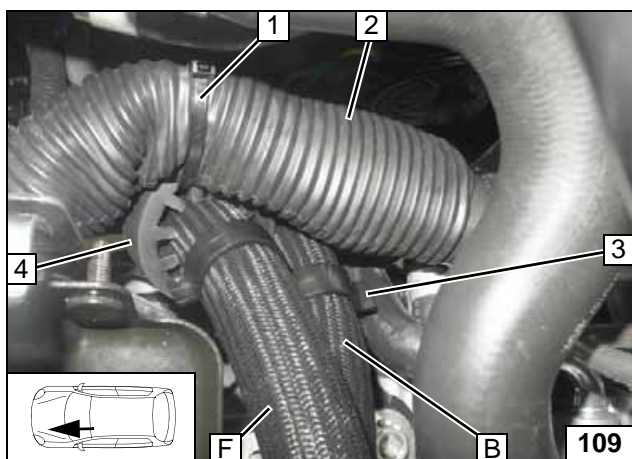

Align black (sw) rubber isolator **4** with original vehicle wiring harness **2** and secure with cable tie **1**!



**3** Hose bracket between hoses **B** and **F**

Routing in engine compartment

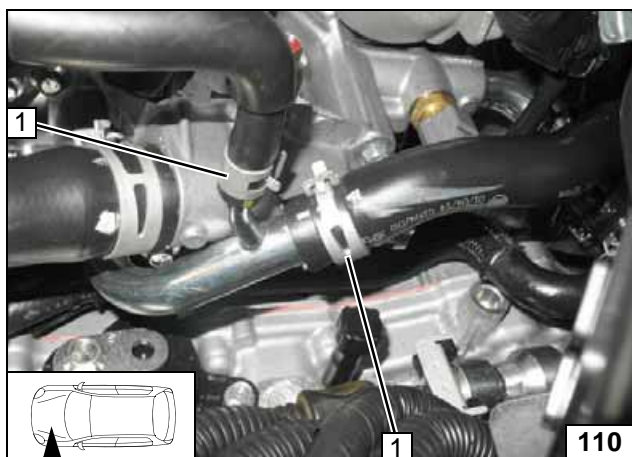

Position original vehicle spring clips **1** [2x] as shown!



Aligning spring clips

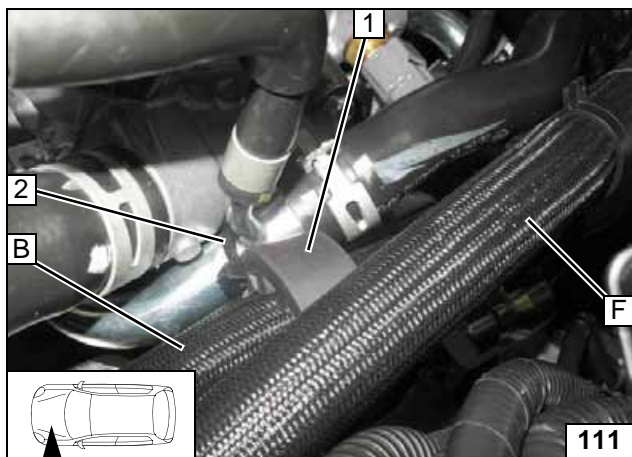

Slide black (sw) rubber isolator **1** onto hose **B**, align with pipe and secure with cable tie **2**!



Routing in engine compartment

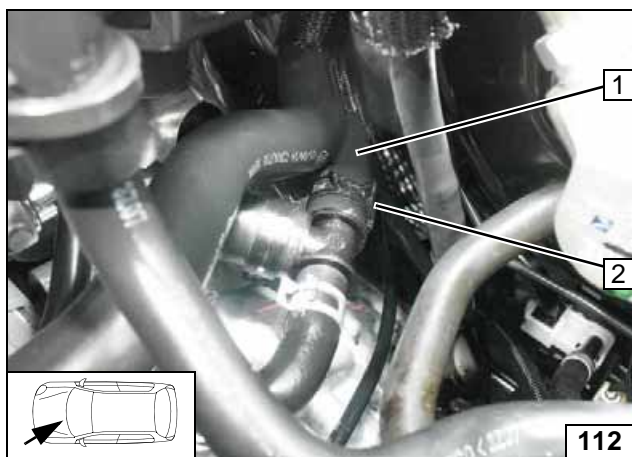

Disconnect hose to heat exchanger inlet **1** from connection point of engine outlet. Spring clip **2** will be reused.



Cutting point

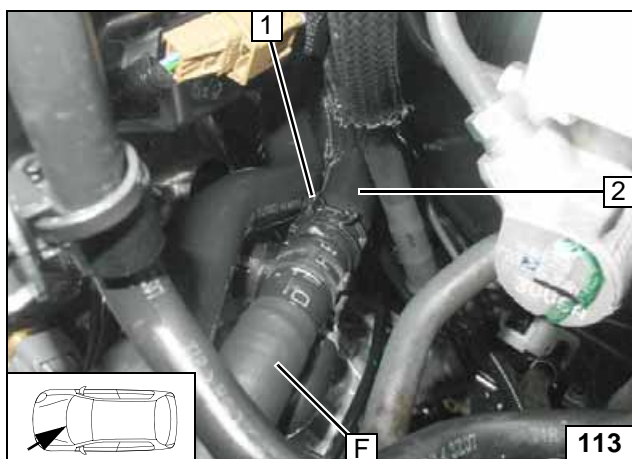

**1** Original vehicle spring clip  
**2** Hose on heat exchanger inlet

Connecting heat exchanger inlet

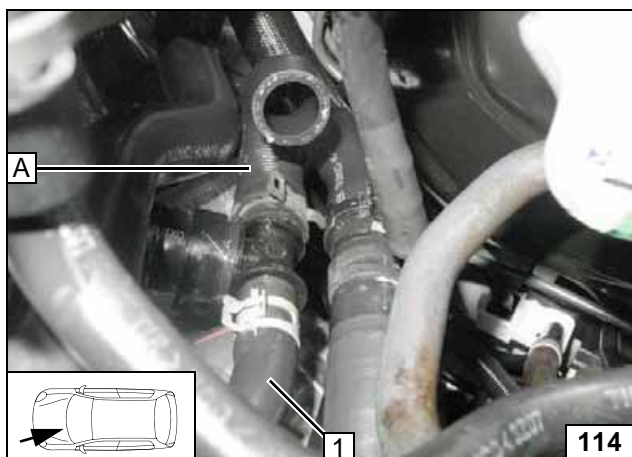

Connect hose **A** to hose on engine outlet **1**, turn to the left and route under the hose of the heat exchanger inlet (see next figure)!



Connecting engine outlet

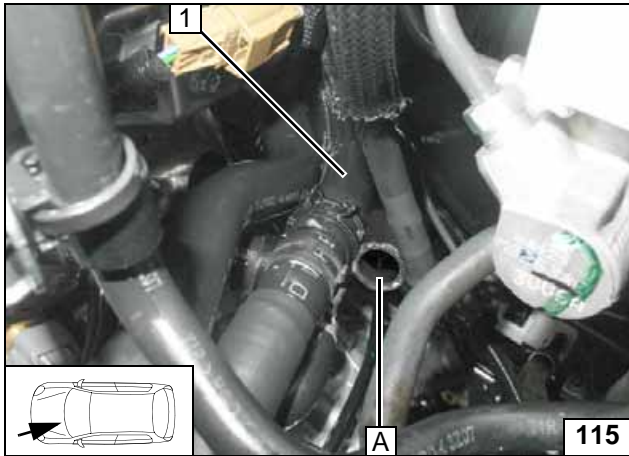

1 Hose on heat exchanger inlet

Aligning hose A

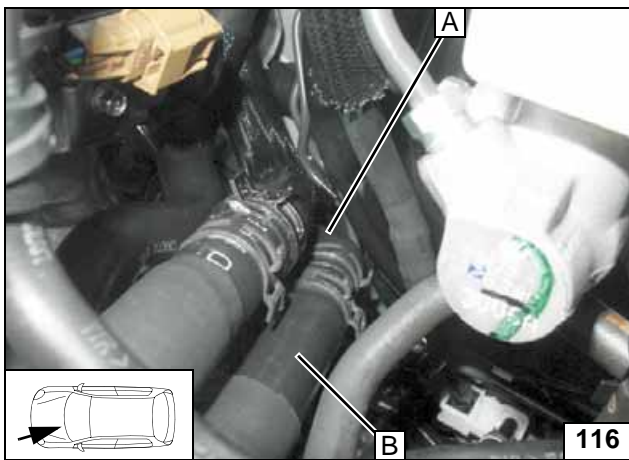

Connecting engine outlet

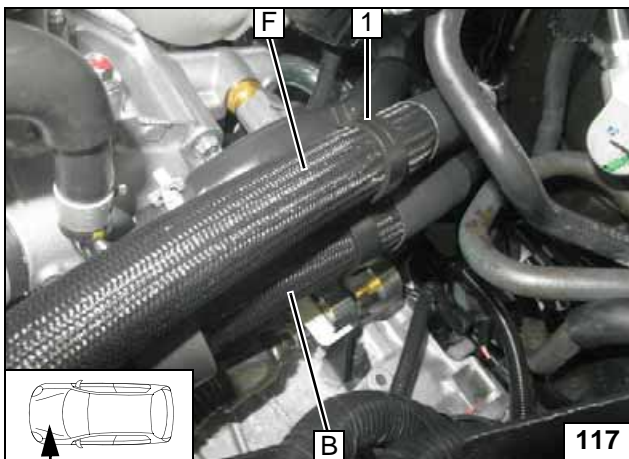

Ensure sufficient distance to neighbouring components, adjust if necessary.

1 Hose bracket between hoses B and F



Aligning hoses



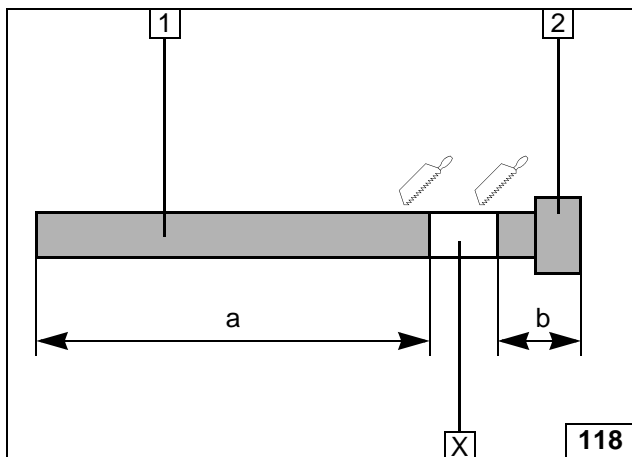
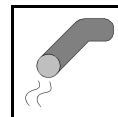

### Exhaust for Automatic Transmission

Discard section X.

- 1 Exhaust pipe  
a = 460
- 2 Exhaust end section  
b = 70

Preparing exhaust pipe

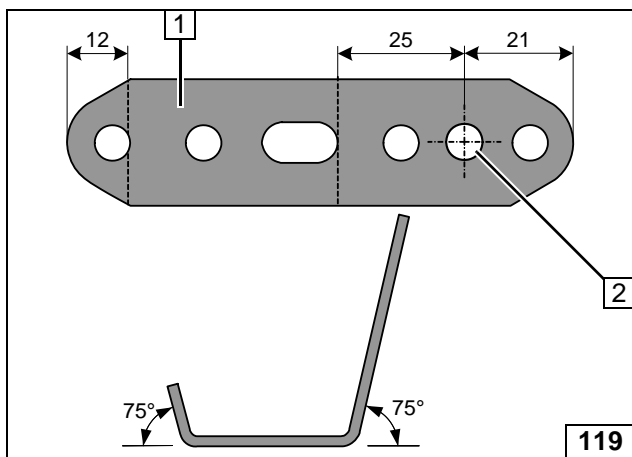

- 1 Perforated bracket
- 2 Drill out hole to 7 mm dia.

Preparing perforated bracket

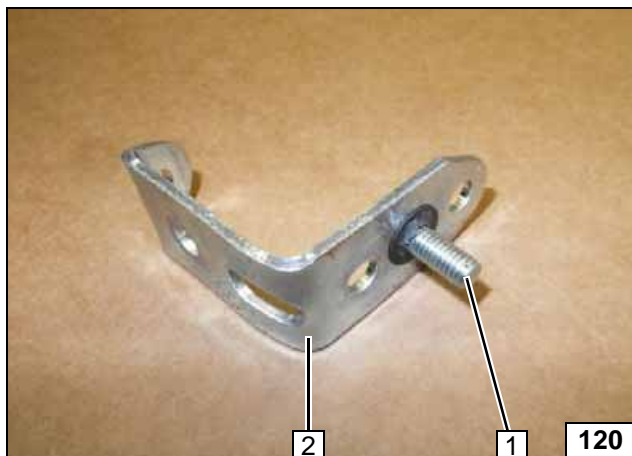

- 1 M6x20 bolt, pin lock
- 2 Perforated bracket

Preparing perforated bracket

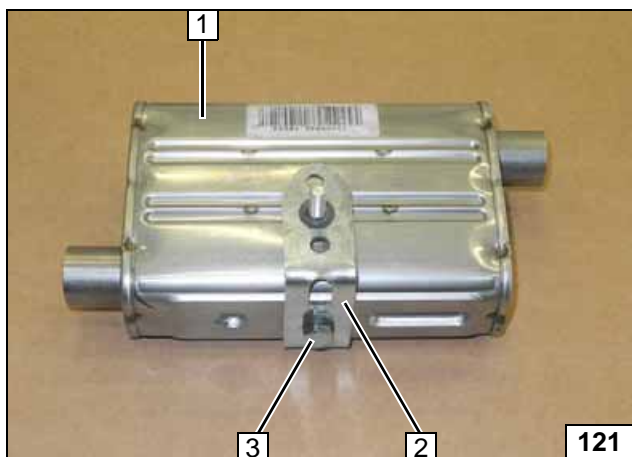

- 1 Silencer
- 2 Perforated bracket
- 3 M6x16 bolt, spring lockwasher

Preparing silencer

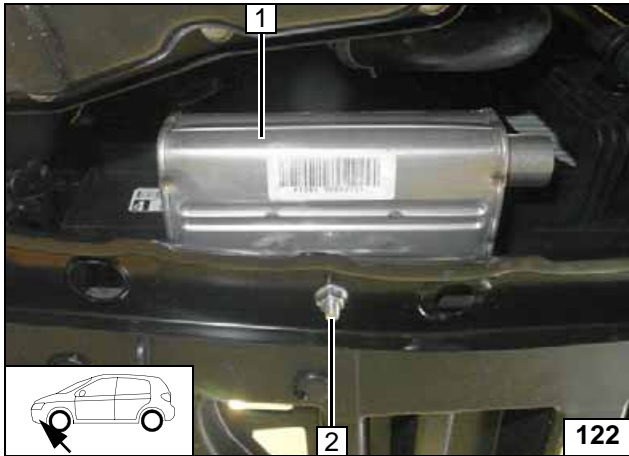
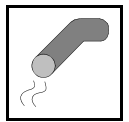

- 1 Silencer
- 2 Flanged nut on premounted M6x20 bolt from perforated bracket

**Mounting silencer**

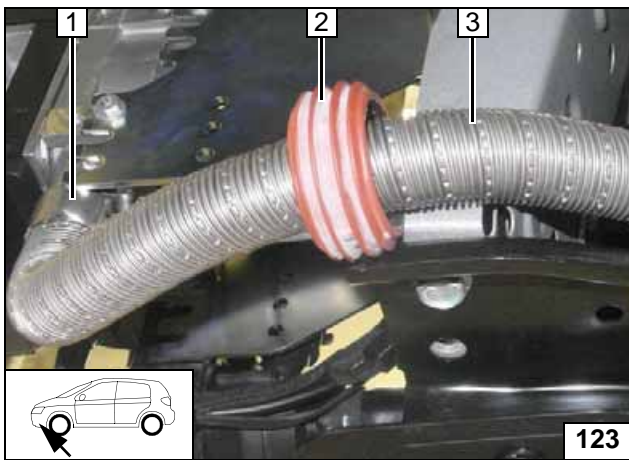

- 1 Hose clamp
- 2 Slide on spacer bracket and align
- 3 Exhaust pipe

**Mounting exhaust pipe**

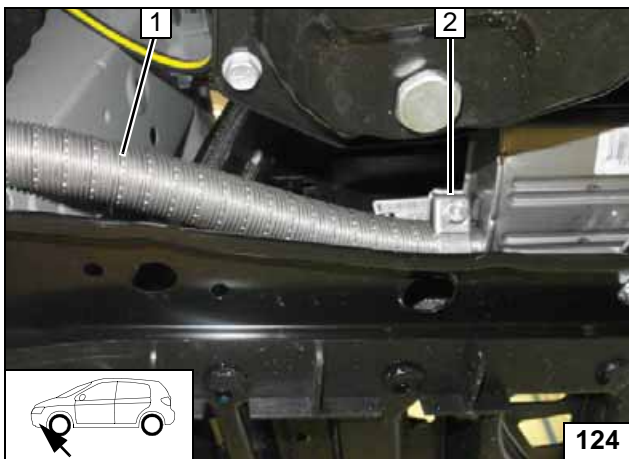

- 1 Exhaust pipe
- 2 Hose clamp

**Mounting exhaust pipe**

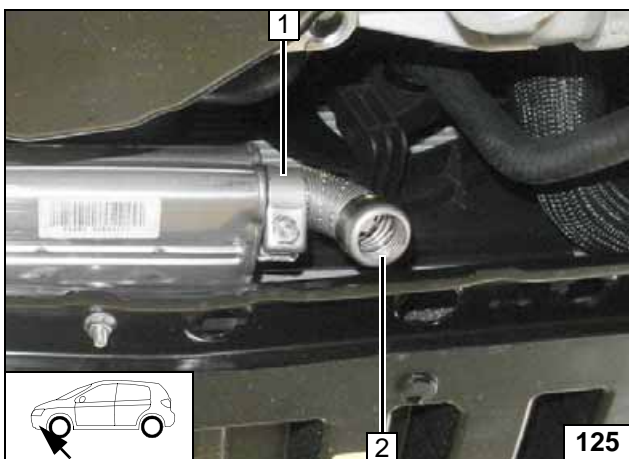

- 1 Hose clamp
- 2 Exhaust end section

**Mounting exhaust end section**

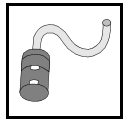

### Combustion Air for All Vehicles

Shown on vehicle with electric auxiliary heater, applies however to all vehicles!

- 1 Combustion air pipe
- 2 Silencer



### Installing combustion air pipe

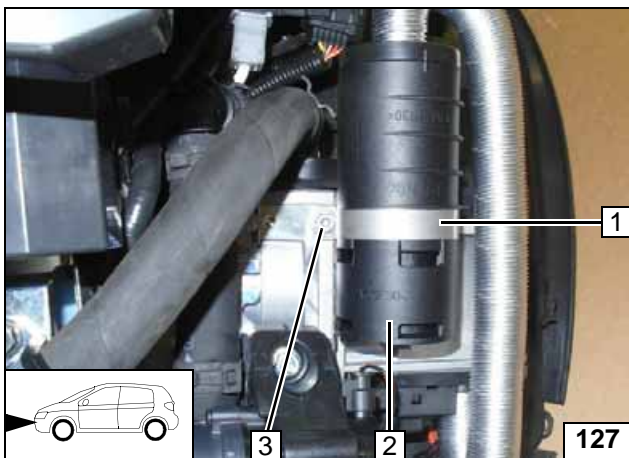

- 1 51 mm dia. clamp
- 2 Silencer
- 3 5x13 self-tapping bolt



### Mounting silencer



## Final Work

### WARNING!

Reassemble the disassembled components in reverse order. Check all hoses, clamps and all electrical connections for firm seating. Insulate all loose lines and tie back.

Only use manufacturer-approved coolant. Spray the heater components with anti-corrosion wax (Tectyl 100K, Order No. 111329).



- Connect the battery.
- Fill and bleed the coolant circuit according to the vehicle manufacturer's specifications
- Program MultiControl CAR, teach Telestart transmitter
- Make settings on A/C control panel according to the "Operating Instructions for End Customer".
- Apply the caution label "Switch off parking heater before refilling" in the area of the filler neck
- See installation instructions for initial start-up and function check

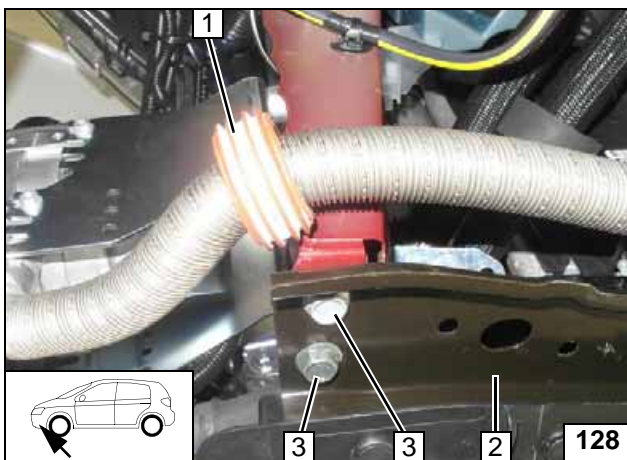

### Only in case of manual transmission

- 1 Align spacer bracket
- 2 Cross member
- 3 Original vehicle bolts (see next image)

Assembling cross member

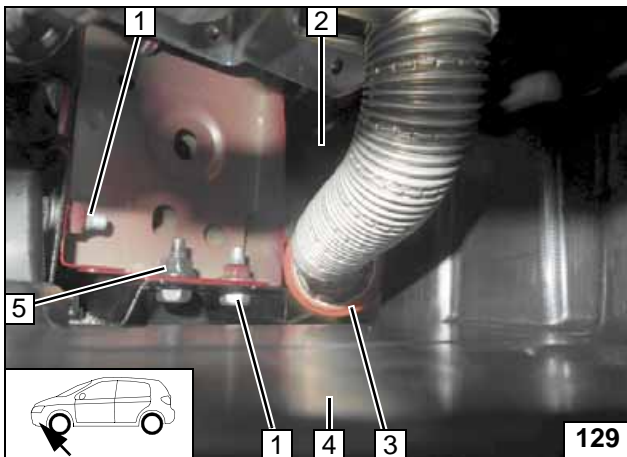

- 1 Original vehicle bolt M8 [2x]
- 2 Wheel well trim installed
- 3 Align spacer bracket
- 4 Cross member
- 5 Original vehicle bolt M8, original vehicle nut

Assembling cross member

Webasto Thermo & Comfort SE  
 Postfach 1410  
 82199 Gilching  
 Germany  
 Internet: [www.webasto.com](http://www.webasto.com)  
 Technical Extranet:  
<http://dealers.webasto.com>

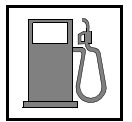

### Template for Fuel Standpipe

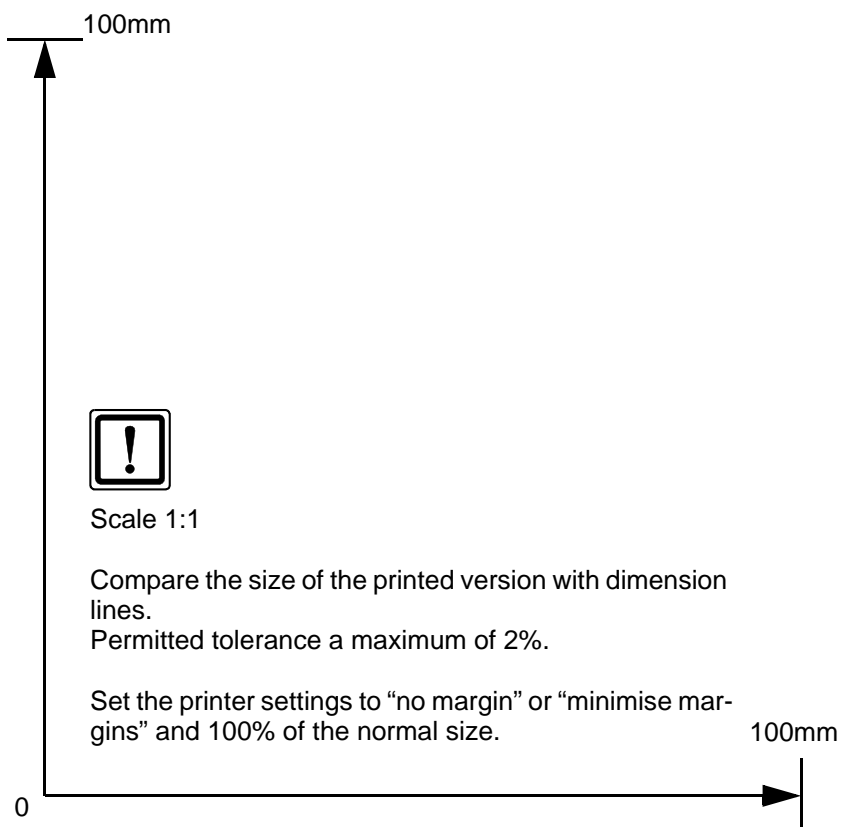

## Operating Instructions for End Customer

Please remove page and add to the vehicle operating instructions.

**Note:**

We recommend matching the heating time to the driving time.

Heating time = driving time

**Example:**

For a driving time of approx. 20 min. (in one direction), we recommend not exceeding a switch-on time of 20 min.

Passenger compartment monitoring, if installed, must be deactivated in addition to vehicle settings for the heating cycle.

Deactivation instructions can be found in the operating instructions of the vehicle.

Before parking the vehicle, make the following settings:

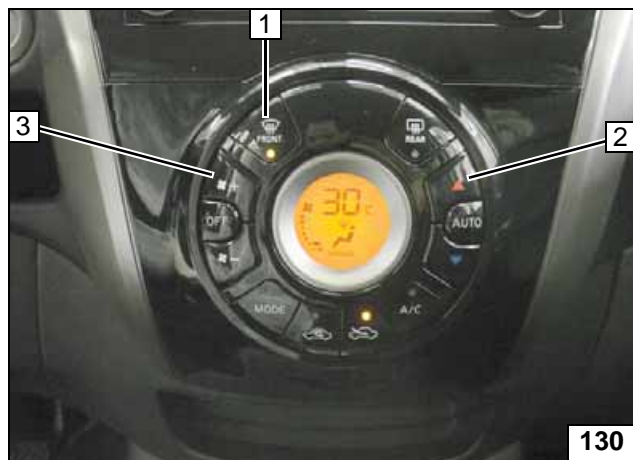

- 1 Air outlet to windscreen
- 2 Set temperature to "HI"
- 3 Set fan to level "2" or max. "3"



A/C control panel

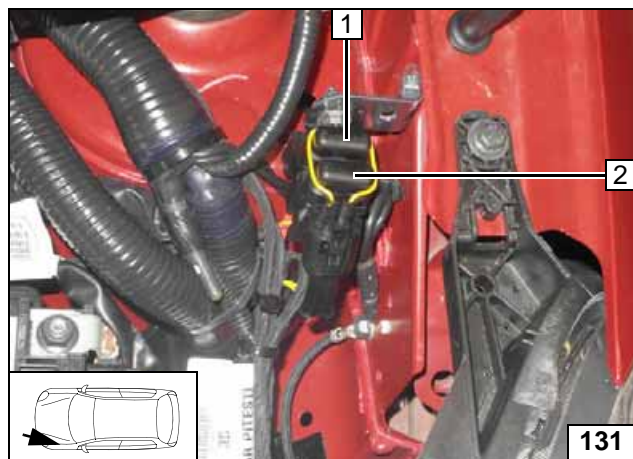

**Manual transmission**

- 1 30A main fuse F2 of passenger compartment
- 2 20A heater fuse F1

Engine compartment fuses

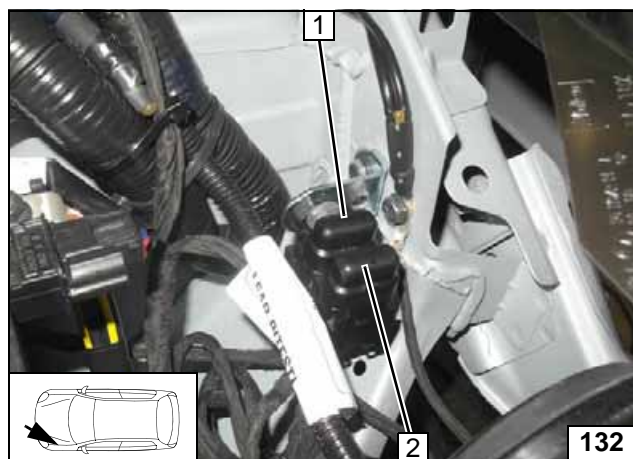

**Automatic transmission**

- 1 30A main fuse F2 of passenger compartment
- 2 20A heater fuse F1

Engine compartment fuses



# Nissan Note

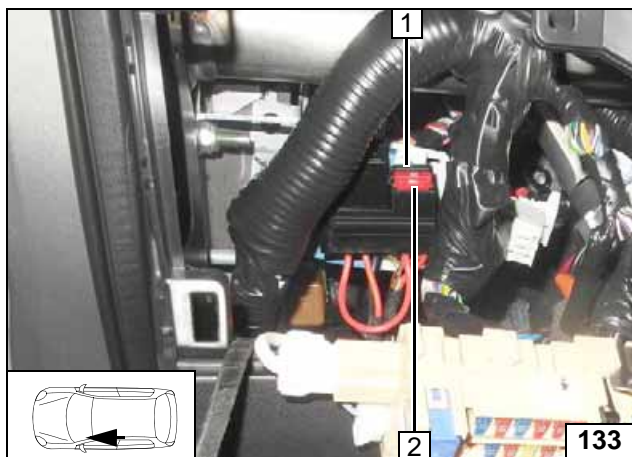

## All vehicles

- 1 1A fuse F3 of heater control
- 2 10A fan fuse F4

Passenger  
compartment  
fuses