

Water Heater

Thermo Top Evo Parking Heater



Installation Documentation

Fiat 500

Validity

Manufacturer	Model	Type	EG-BE No./ ABE
Fiat	500	312AXG1A	e3 * 2007 / 46 * 0064 * ...
Fiat	500	312AXA1A	e3 * 2007 / 46 * 0064 * ...

Motorisation	Fuel	Transmission type	Output in kW	Displacement in cm ³	Engine code
0.9 P	Petrol	5-speed SG	63	875	312A2000
1.2 P	Petrol	5-speed SG	51	1242	169A4000

SG = manual transmission

From Model Year 2014

Left-hand drive vehicle

Verified equipment variants: Manual air-conditioning
 Automatic air-conditioning
 Front fog lights
 2 WD

Not verified: Passenger compartment monitoring
 Start - Stop
 Bi-Xenon and headlight washer system

Total installation time: approx. 7.5 hours

Table of Contents

Validity	1	Preparing Installation Location	16
Necessary Components	2	Preparing Heater	18
Installation Overview	2	Installing Heater	19
Information on Total Installation Time	2	Fuel	20
Information on Operating and Installation Instructions	3	Coolant Circuit for 0.9 P (Island)	24
Information on Validity	4	Coolant Circuit for 1.2 P	28
Technical Information	4	Combustion Air	32
Explanatory Notes on Document	4	Exhaust Gas	33
Preliminary Work	5	Final Work	35
Heater Installation Location	5	Operating Instructions for Manual Air-Conditioning	36
Preparing Electrical System	6	Operating Instructions for Automatic Air-Conditioning	37
Electrical System	9		
Fan Controller for Manual Air-Conditioning	10		
Fan Controller for Automatic Air-Conditioning	12		
MultiControl CAR Option	14		
Remote Option (Telestart)	14		
Thermo Call Option	15		

Necessary Components

- Basic delivery scope of *Thermo Top Evo* based on price list
- Installation kit for Fiat 500 2014 Petrol: **1322263B**
- Required additionally for 0.9 P: Additional kit for Fiat 500 0.9 P island based circuit: **1324004A**
- Required additionally for automatic air-conditioning: Additional kit for automatic air-conditioning: **1320864B**
- Heater control in accordance with price list and upon consultation with end customer
- In case of Telestart, indicator lamp in accordance with price list and in consultation with end customer

Installation instructions:

- Arrange for the vehicle to be delivered with the tank only about ¼ full.
- The installation location of the push button for Telestart or Thermo Call must be agreed with the end customer.
- Depending on the available space and manufacturer's instructions, we recommend the use of a vehicle battery with more electrical capacity.

Installation Overview

Legend:

1. Heater
2. Engine compartment fuse holder
3. Passenger compartment relay and fuse holder
4. PWM-Gateway
5. Circulating pump
6. MultiControl CAR
7. Metering pump

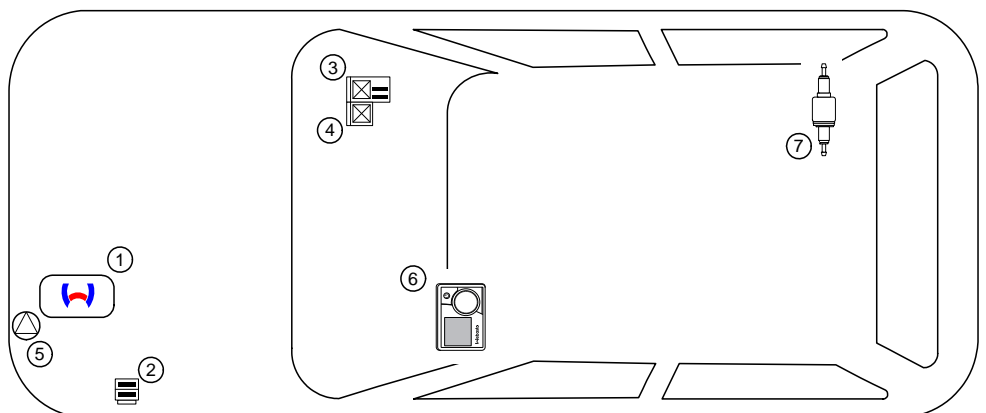

Information on Total Installation Time

The total installation time includes the time needed for mounting and demounting of the vehicle-specific components, the heater specific installation time and all other times required for the system integration and initial start-up of the heater.

The total installation time may vary for vehicle equipment other than provided.

Information on Operating and Installation Instructions

1 Important notes (not complete)

1.1 Installation and Repair



The improper installation or repairing of Webasto heating and cooling systems can cause fire or the leakage of deadly carbon monoxide, leading to serious injury or death.



To install and repair Webasto heating and cooling systems you need to have completed a special company training course and have the appropriate technical documentation, special tools and special equipment.



Installation and repair may ONLY be carried out by persons trained and certified in a Webasto training course. NEVER try to install or repair Webasto heating or cooling systems if you have not completed a Webasto training course, you do not have the necessary technical skills and you do not have the technical documentation, tools and equipment available to ensure that you can complete the installation and repair work properly.

Only use genuine Webasto parts. See the Webasto air and water heaters accessories catalogue for this purpose.

1.2 Operation

To ensure safe operation, we recommend having the heater checked every two years by an authorised Webasto dealer, especially when used over a long period and/or under extreme environmental conditions.

Do not operate the heater in closed rooms due to the danger of poisoning and suffocation.

Always switch off the heater before refuelling.

The heater may only be used with the prescribed fuel diesel (DIN EN 590) or petrol (DIN EN 228).

The heater may not be cleaned with a high-pressure cleaner.

1.3 Please note

ALWAYS follow all Webasto installation and operating instructions and observe all warnings.

To become familiar with and understand all functions and properties of the heater, the operating instructions must be read carefully and observed at all times.

For proper, safe installation and repair work, the installation instructions with all warnings and safety information must be carefully read and observed at all times. Please always contact a workshop authorised by Webasto for all installation and repair work.

Important

Webasto shall assume no liability for defects, damage and injuries resulting from a failure to observe the installation, repair and operating instructions of the information contained in them.

This liability exclusion particularly applies to improper installations and repairs, installations and repairs by untrained persons or in the case of a failure to use genuine spare parts.

The liability due to culpable disregard to life, limb or health and due to damage or injuries caused by a wilful or reckless breach of duty remain unaffected, as does the obligatory product liability.

Installation should be carried out according to the general, standard rules of technology. Unless specified otherwise, fasten hoses, lines and wiring harnesses to original vehicle lines and wiring harnesses using cable ties. Insulate loose wire ends and tie back. Connectors on electronic components must audibly snap into place during assembly.

Sharp edges should be fitted with rub protection. Spray unfinished body areas, e.g. drilled holes, with anti-corrosion wax (Tectyl 100K, Order No. 111329).

Observe the instructions and guidelines of the respective vehicle manufacturer for demounting and mounting vehicle specific components!

The initial startup is to be executed with the Webasto Thermo Test Diagnosis.

When installing a programmable control module (e.g. a PWM Gateway), the corresponding settings must be checked or adjusted.

2 Statutory regulations governing installation

Guidelines	TT-Evo
Heating Directive ECE R122	E1 00 0258
EMC Directive ECE R10	E1 04 5627

Note

The regulations of these guidelines are binding in the scope of the Directive 70/156/EEC and/or 2007/46/EC (for new vehicle models from 29/04/2009) and should also be observed in countries in which there are no special regulations.

Important

Failure to follow the installation instructions will result in the invalidation of the type approval for the heater and therefore invalidation of the general **homologation of the vehicle**.

Note

The heater is licensed in accordance with paragraph 19, section 3, No. 2b of the StVZO (German Road Traffic Licensing Authority).

2.1 Excerpt from the directive 122 (heater) section 5 for the installation of the heater.

Beginning of excerpt.

ANNEX VII

REQUIREMENTS FOR COMBUSTION HEATERS AND THEIR INSTALLATION

1. GENERAL REQUIREMENTS

1.7.1. A clearly visible tell-tale in the operator's field of view shall inform when the combustion heater is switched on or off.

2. VEHICLE INSTALLATION REQUIREMENTS

2.1. Scope

2.1.1. Subject to paragraph 2.1.2. combustion heaters shall be installed according to the requirements of this Annex.

2.1.2. Vehicles of category O having liquid fuel heaters are deemed to comply with the requirements of this Annex.

2.2. Positioning of heater

2.2.1. Body sections and any other components in the vicinity of the heater must be protected from excessive heat and the possibility of fuel or oil contamination.

2.2.2. The combustion heater shall not constitute a risk of fire, even in the case of overheating. This requirement shall be deemed to be fulfilled if the installation ensures an adequate distance to all parts and suitable ventilation, by the use of fire resistant materials or by the use of heat shields.

2.2.3. In the case of M2 and M3 vehicles, the heater must not be positioned in the passenger compartment. However, an installation in an effectively sealed envelope which also complies with the conditions in paragraph 2.2.2 may be used.

2.2.4. The label referred to in paragraph 1.4 or a duplicate, must be positioned so that it can be easily read when the heater is installed in the vehicle.

2.2.5. Every reasonable precaution should be taken in positioning the heater to minimise the risk of injury and damage to personal property.

2.3. Fuel supply

2.3.1. The fuel filler must not be situated in the passenger compartment and must be provided with an effective cap to prevent fuel spillage

2.3.2. In the case of liquid fuel heaters, where a supply separate to that of the vehicle is provided, the type of fuel and its filler point must be clearly labelled

2.3.3. A notice, indicating that the heater must be shut down before refuelling, must be affixed to the fuelling point. In addition a suitable instruction must be included in the manufacturer's operating manual.

2.4. Exhaust system

2.4.1. The exhaust gas outlet must be located so as to prevent emissions from entering the vehicle through ventilators, heated air inlets or opening windows.

2.5. Combustion air inlet

2.5.1. The air for the combustion chamber of the heater must not be drawn from the passenger compartment of the vehicle.

2.5.2. The air inlet must be so positioned or guarded that blocking by rubbish or luggage is unlikely.

2.6. Heating air inlet

2.6.1. The heating air supply may be fresh or recirculated air and must be drawn from a clean area not likely to be contaminated by exhaust fumes emitted either by the propulsion engine, the combustion heater or any other vehicle source.

2.6.2. The inlet duct must be protected by mesh or other suitable means.

2.7. Heating air outlet

2.7.1. Any ducting used to route the hot air through the vehicle must be so positioned or protected that no injury or damage could be caused if it were to be touched.

2.7.2. The air outlet must be so positioned or guarded that blocking by rubbish or luggage is unlikely.

End of excerpt.

In multilingual versions the German language is binding.

Information on Validity

This installation documentation applies to Fiat 500 Petrol vehicles - for validity, see page 1 - from model year 2014 and later, assuming technical modifications to the vehicle do not affect installation, any liability claims excluded. Depending on the vehicle version and equipment, modifications may be necessary during installation with respect to this installation documentation.

Vehicle and engine types, equipment variants and other specifications not listed in this installation documentation have not been tested. However, installation according to this installation documentation may be possible.

Technical Information

Special tools

- Hose clamp pliers for self-clamping hose clamps
- Hose clamp pliers for Clic hose clamps of type W
- Automatic wire stripper 0.2 - 6mm²
- Crimping pliers for cable lug / tab connector 0.5 - 6mm²
- Torque wrench for 2.0 - 10 Nm
- Hose clamping pliers
- Metric thread-setter kit
- Webasto Thermo Test Diagnosis with current software

Dimensions

- All dimensions are in mm











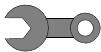



Tightening torque values

- Tightening torque values of 5x13 heater bolts and 5x11 heater stud bolts = 8 Nm.
- Tightening torque values of 5x15 bolts for retaining plate of water connection piece = 7Nm.
- Tighten other bolt connections in accordance with manufacturer's instructions or in accordance with state-of-the-art-technology.

Explanatory Notes on Document

You will find an identification mark on the outside top right corner of the page in question to provide you with a quick overview of the individual working steps.

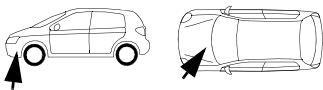
Special features are highlighted using the following symbols:

Mechanical system		Specific risk of injury or fatal accidents.	
Electrical System		Specific risk due to electrical voltage.	
Coolant circuit		Specific risk of damage to components.	
Combustion air		Specific risk of fire or explosion.	
Fuel		Reference to general installation instructions of the Webasto components or to the manufacturer's vehicle-specific documents	
		Reference to a special technical feature.	
Exhaust gas		The arrow in the vehicle icon indicates the position on the vehicle and the viewing angle	
Software		Tightening torque according to the manufacturer's vehicle-specific documents	

Fiat 500

Preliminary Work

Vehicle

- Open the fuel tank cap.
- Ventilate the fuel tank.
- Close the fuel tank cap again.
- Depressurise the cooling system.
- Disconnect the battery and remove completely, including the carrier.
- Take off the engine cover.
- Remove the air filter together with the intake hose (only for 0.9 P).
- Remove the left front wheel.
- Remove the left-hand wheel well trim.
- Remove the underride protection (if present).
- Remove the trim of the fuel lines on the underbody.
- Remove the footwell trim on the front passenger's side.

Heater

- Remove years that do not apply from the type and duplicate label.
- Attach the duplicate label (type label) in the appropriate place in the engine compartment.

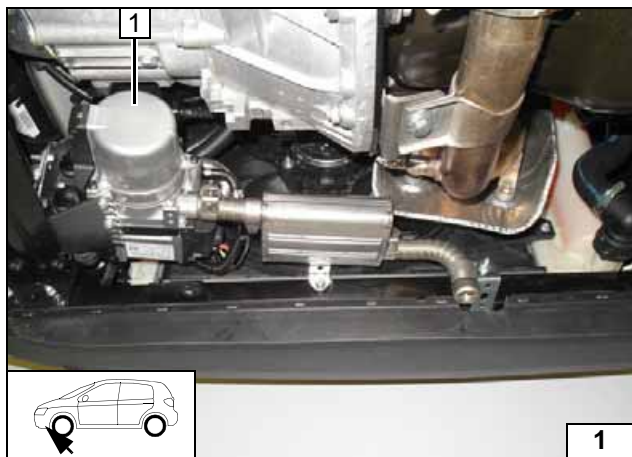

Heater Installation Location

1 Heater

Installation
location

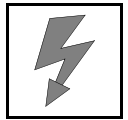

Preparing Electrical System

Wire sections retain their numbering throughout the whole document.

Produce all following electrical connections as shown in the wiring diagram.

Manual air-conditioning

- ① Red (rt) wire of fan wiring harness
- ② Black (sw) wire of fan wiring harness



Assigning wires

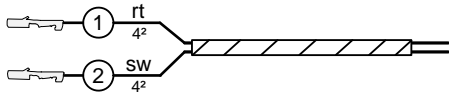

2

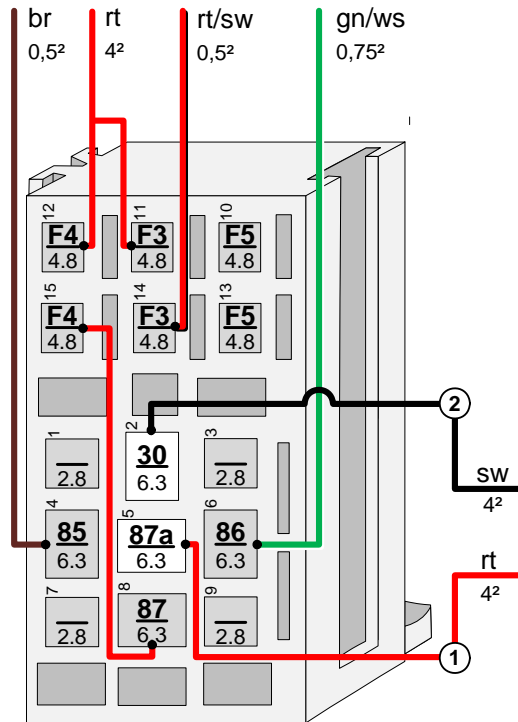

Connecting wires to passenger compartment relay and fuse holder

3

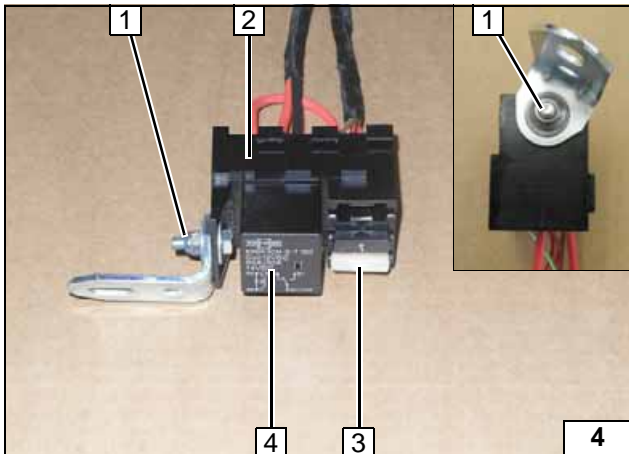

- 1 M5x16 bolt, angle bracket, large diameter washer [2x], nut
- 2 Passenger compartment relay and fuse holder
- 3 25A fuse F4
- 4 K1 relay



Premounting passenger compartment relay and fuse holder

4

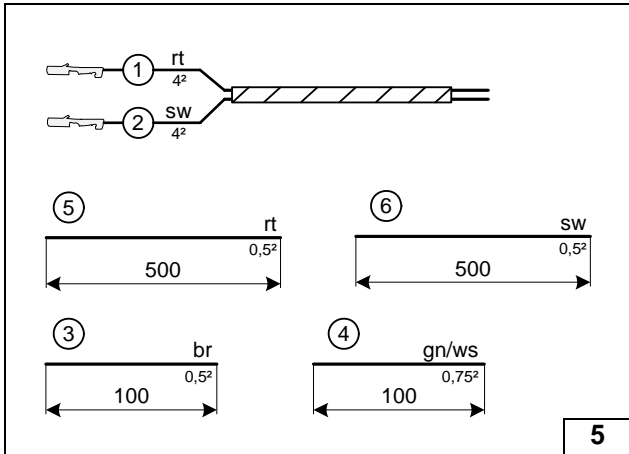
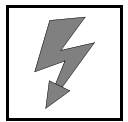

Automatic air-conditioning

Pull wire sections ⑤ and ⑥ into supplied protective sleeving.

- ① Red (rt) wire of fan wiring harness
- ② Black (sw) wire of fan wiring harness



Cutting to length / assigning wires

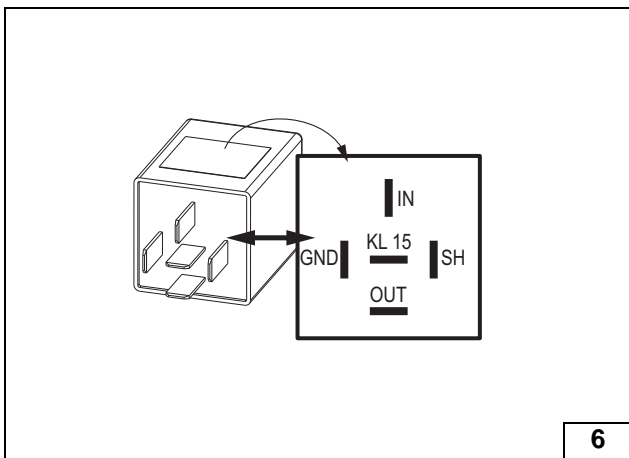

The settings of the PWM Gateway are to be checked before the heater start-up, and adjusted if necessary.

Settings:

- Duty cycle: 25%
- Frequency: 1000Hz
- Voltage: 4.8V
- Function: High side



Preparing PWM GW

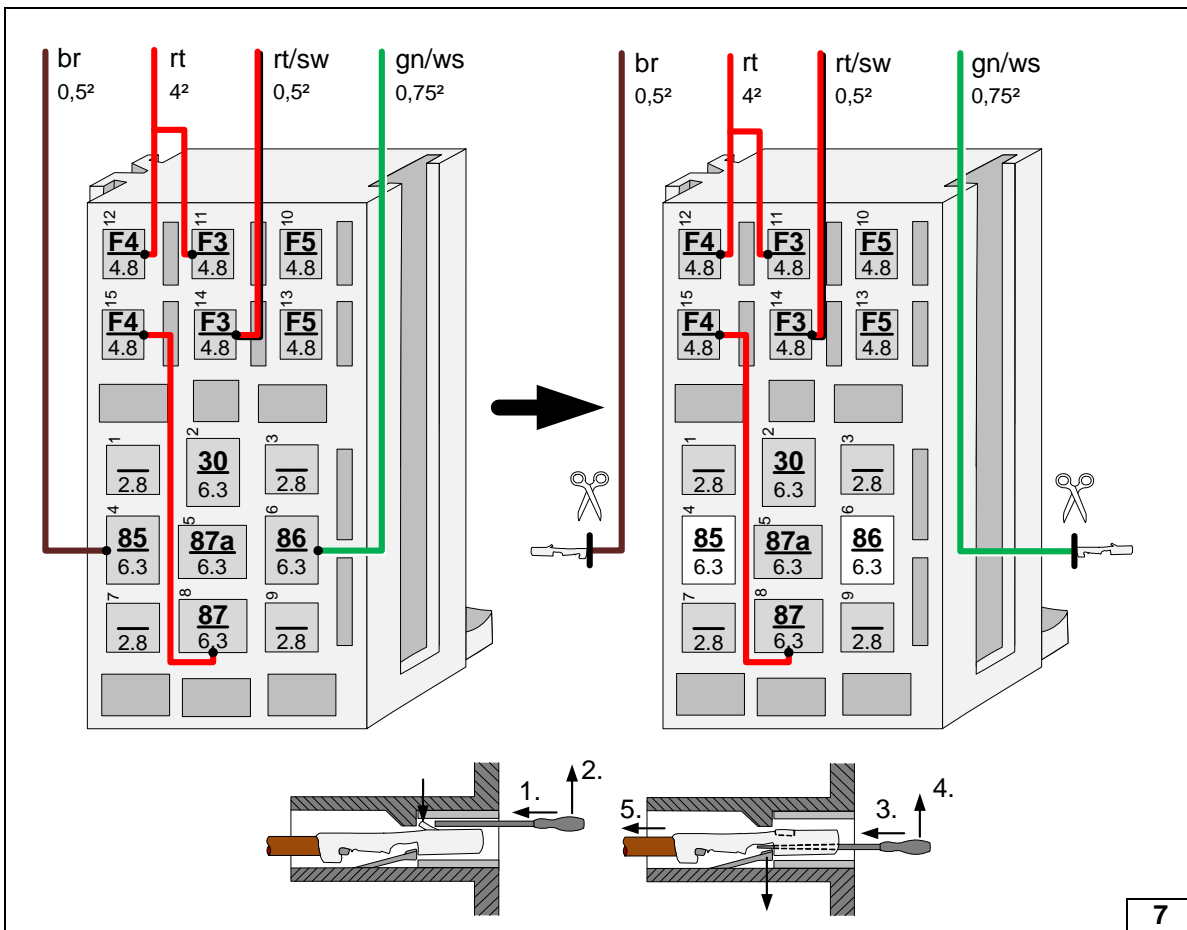

Preparing relay and fuse holder of passenger compartment

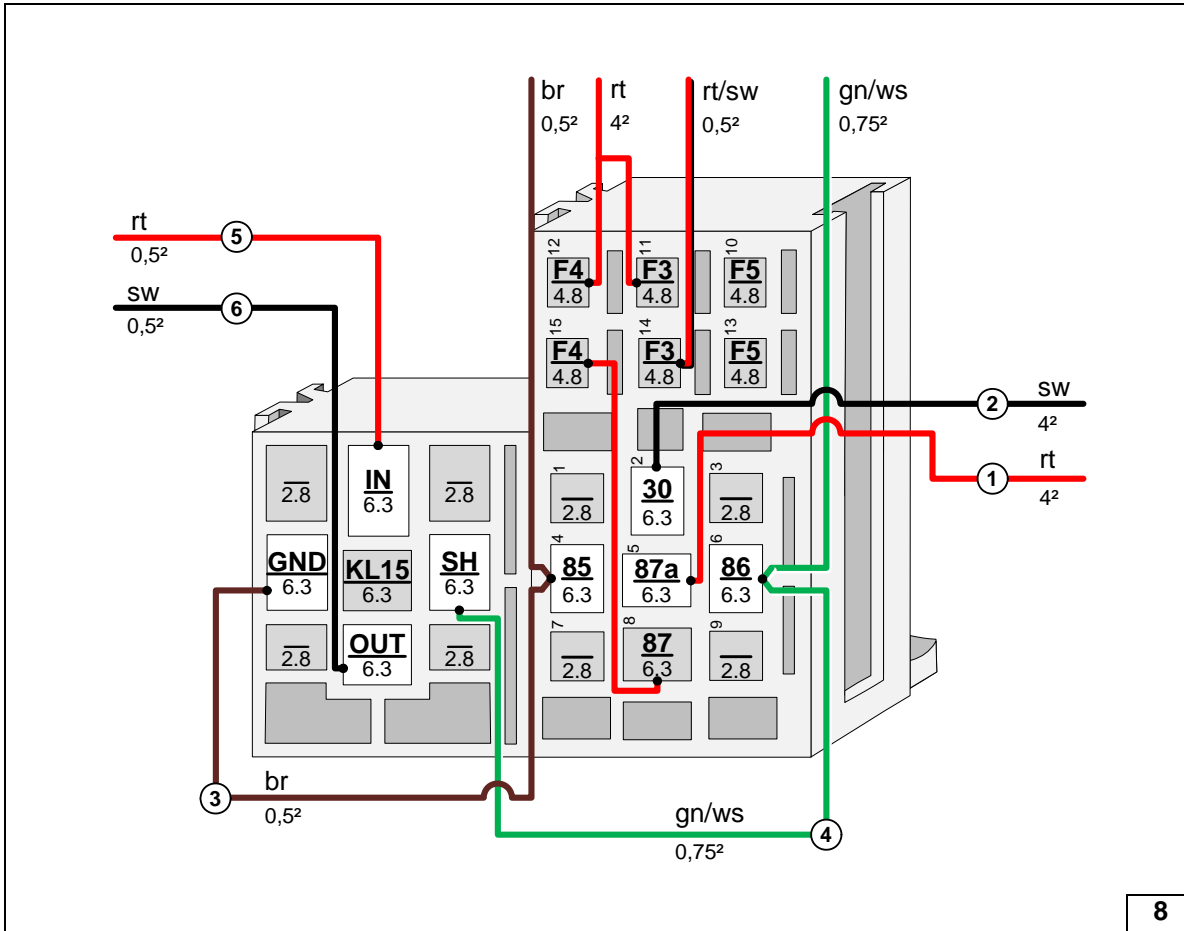

Interlocking PWM GW socket and passenger compartment relay and fuse holder, connecting wires

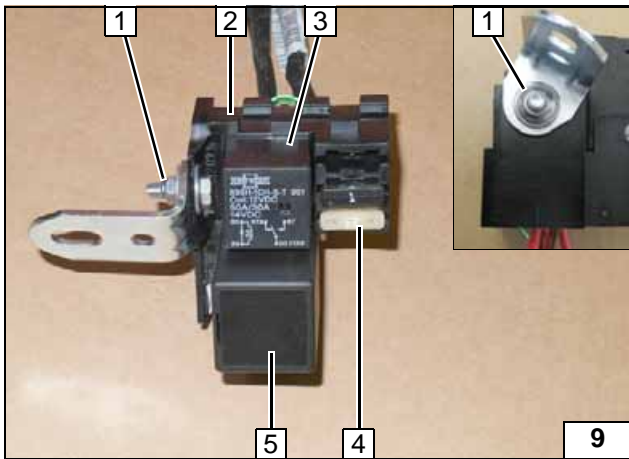

- 1 M5x16 bolt, angle bracket, large diameter washer [2x], nut
- 2 Passenger compartment relay and fuse holder
- 3 K1 relay
- 4 25A fuse F4
- 5 PWM-Gateway



Premounting passenger compartment relay and fuse holder

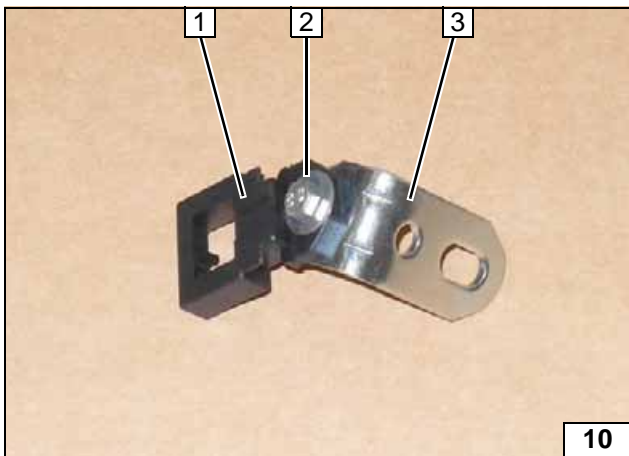

All vehicles

- 1 Retaining plate of fuse holder
- 2 M5x16 bolt, large diameter washer [2x], nut
- 3 Angle bracket



Preparing engine compartment fuse holder



Electrical System

Earth wire

- 1 Earth wire on negative battery terminal

Wiring harness pass through

- 1 Protective rubber plug
- 2 Wiring harness of heater, heater control

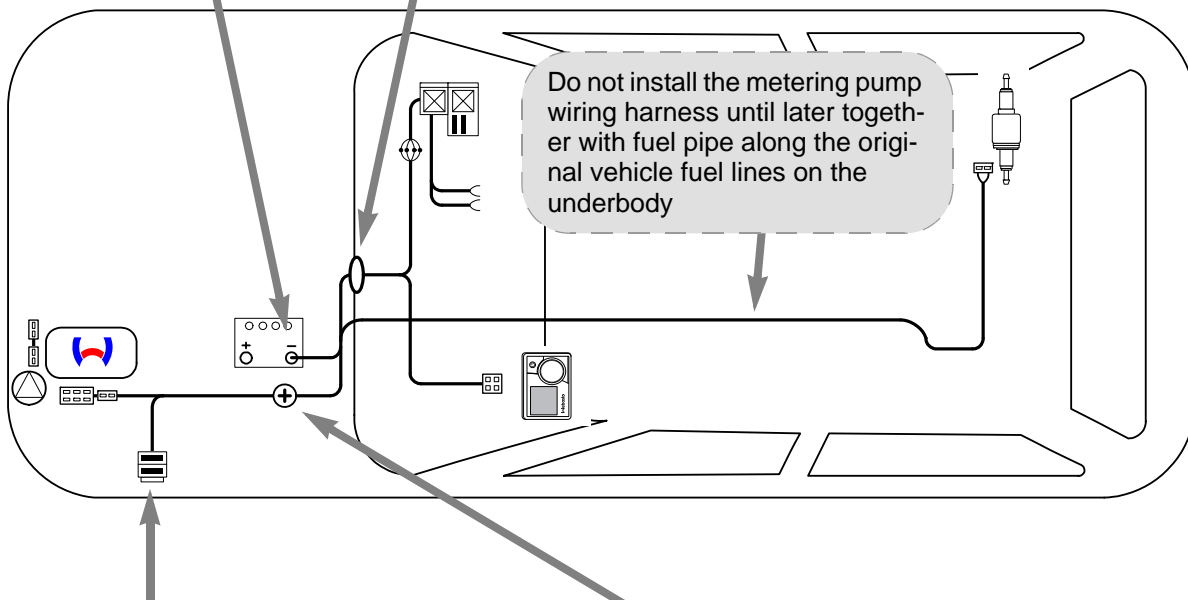
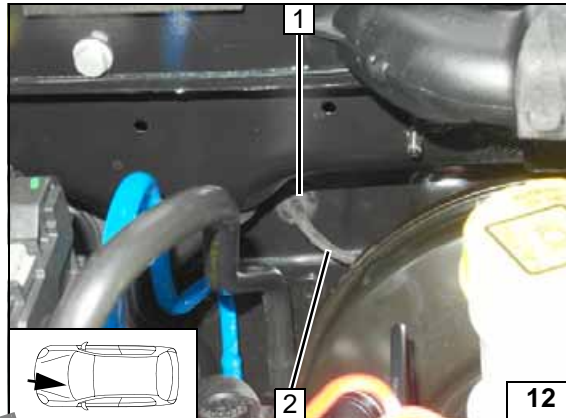
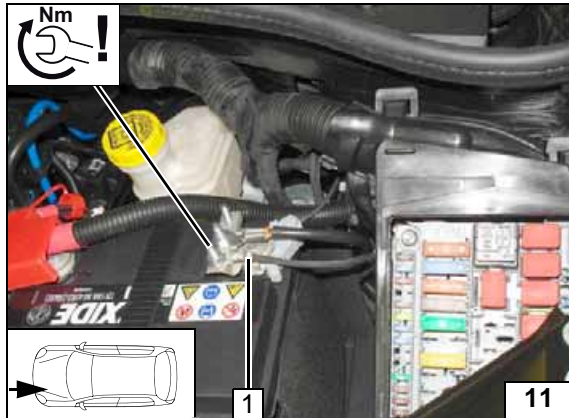

Wiring harness routing diagram

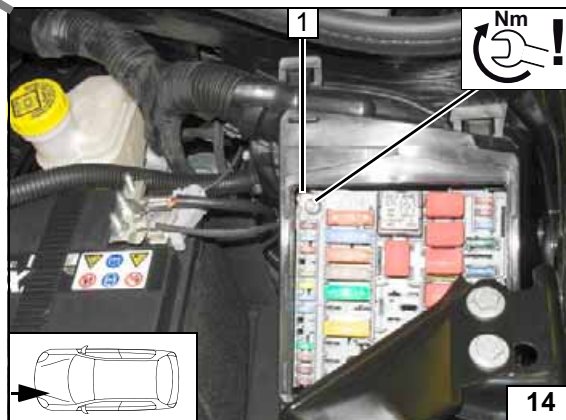
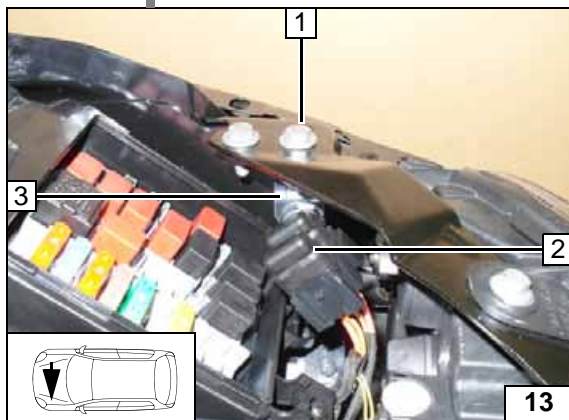

Engine compartment fuse holder

- 1 M8 flanged nut on original vehicle bolt
- 2 Fuses F1-2
- 3 Angle bracket

Positive wire

- 1 Positive wire on positive support point

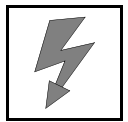

Fan Controller for Manual Air-Conditioning

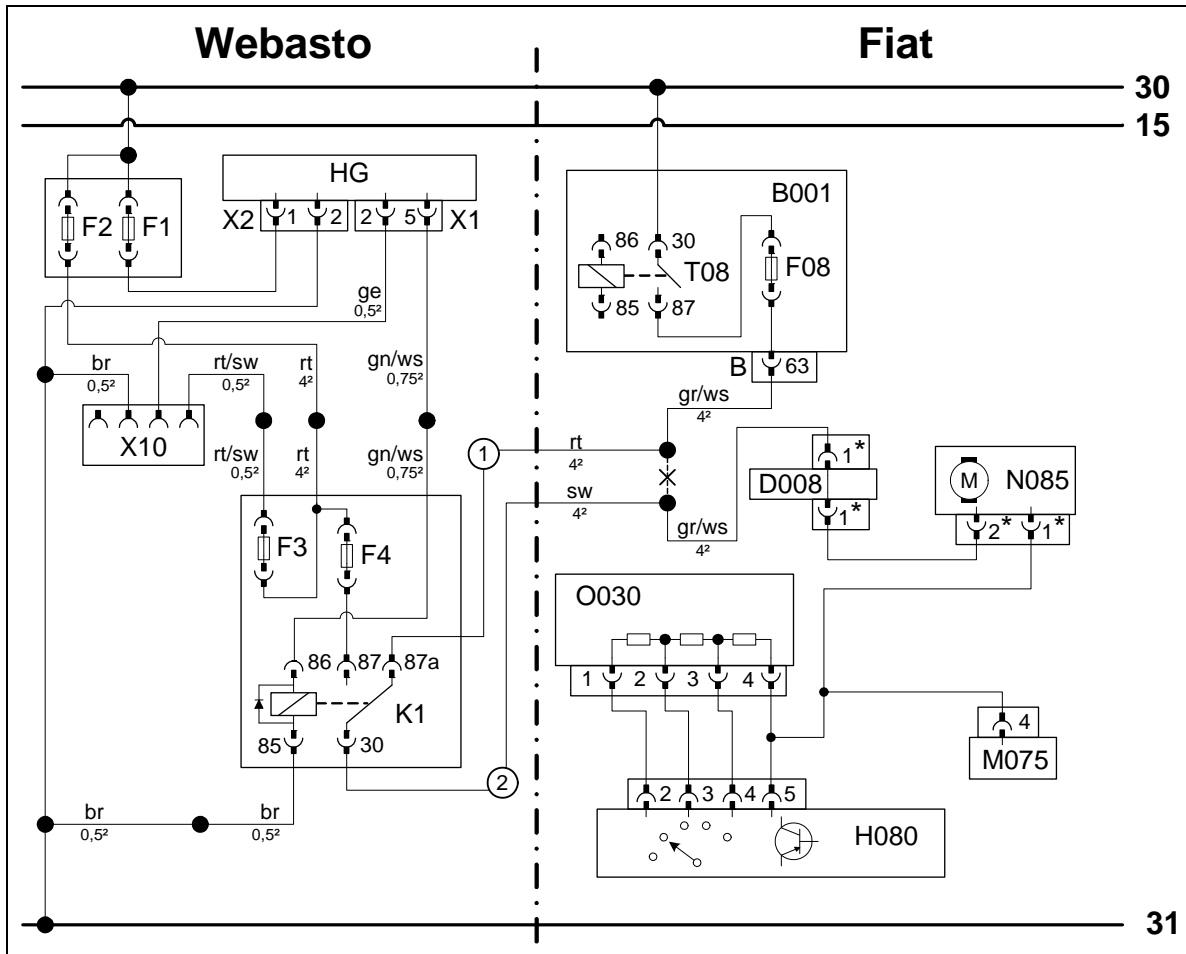

Wiring diagram

Webasto components		Vehicle components		Colours and symbols	
HG	TT-Evo Heater	B001	Central electrical box	rt	red
X1	6-pin heater connector	F08	30A fuse	sw	black
X2	2-pin heater connector	T08	Fan relay	ge	yellow
F1	20A fuse	B	Connector B001	gn	green
F2	30A fuse	D008	Connector	ws	white
X10	4-pin connector of heater control	N085	Fan motor	br	brown
F3	1A fuse	O030	Resistor group	gr	grey
F4	25A fuse	M075	Electronic parking heater		
K1	Fan relay	H080	Switch/A/C control panel		
				*	Pin assignment may vary
				X	Cutting point
					Wiring colours may vary.

Legend

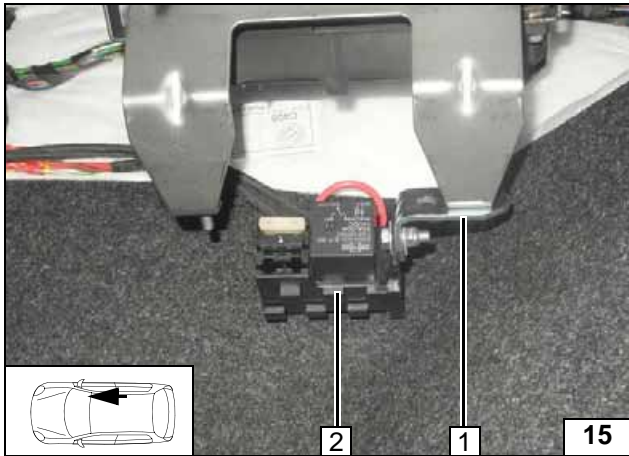
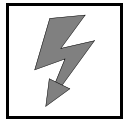

- 1 M5 flanged nut, premounted angle bracket, original vehicle stud bolt
- 2 Passenger compartment relay and fuse holder

Installing relay and fuse holder of passenger compartment

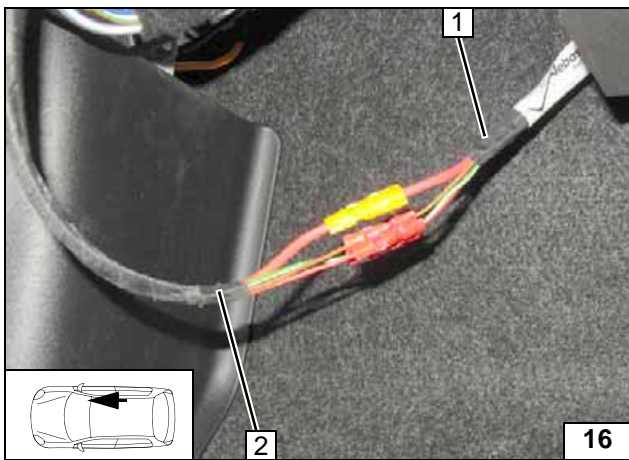

- 1 Wiring harness of passenger compartment relay and fuse holder
- 2 Wiring harness of heater

Connecting same colour wires of wiring harnesses

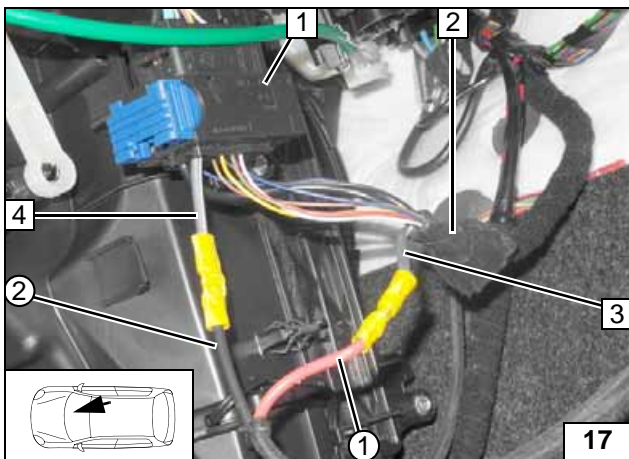

Remove wiring harness wrapping 2 from original vehicle wiring harness.

- 1 Connector D008 (can vary depending on the equipment!)
- 3 Grey/white (gr/ws) wire of fuse F08
- 4 Grey/white (gr/ws) wire of connector D008 / Pin 1 (can vary depending on the equipment!)
- ① Red (rt) wire from K1/87a, fan wiring harness
- ② Black (sw) wire from K1/30, fan wiring harness



Connection of fan motor



Fan Controller for Automatic Air-Conditioning

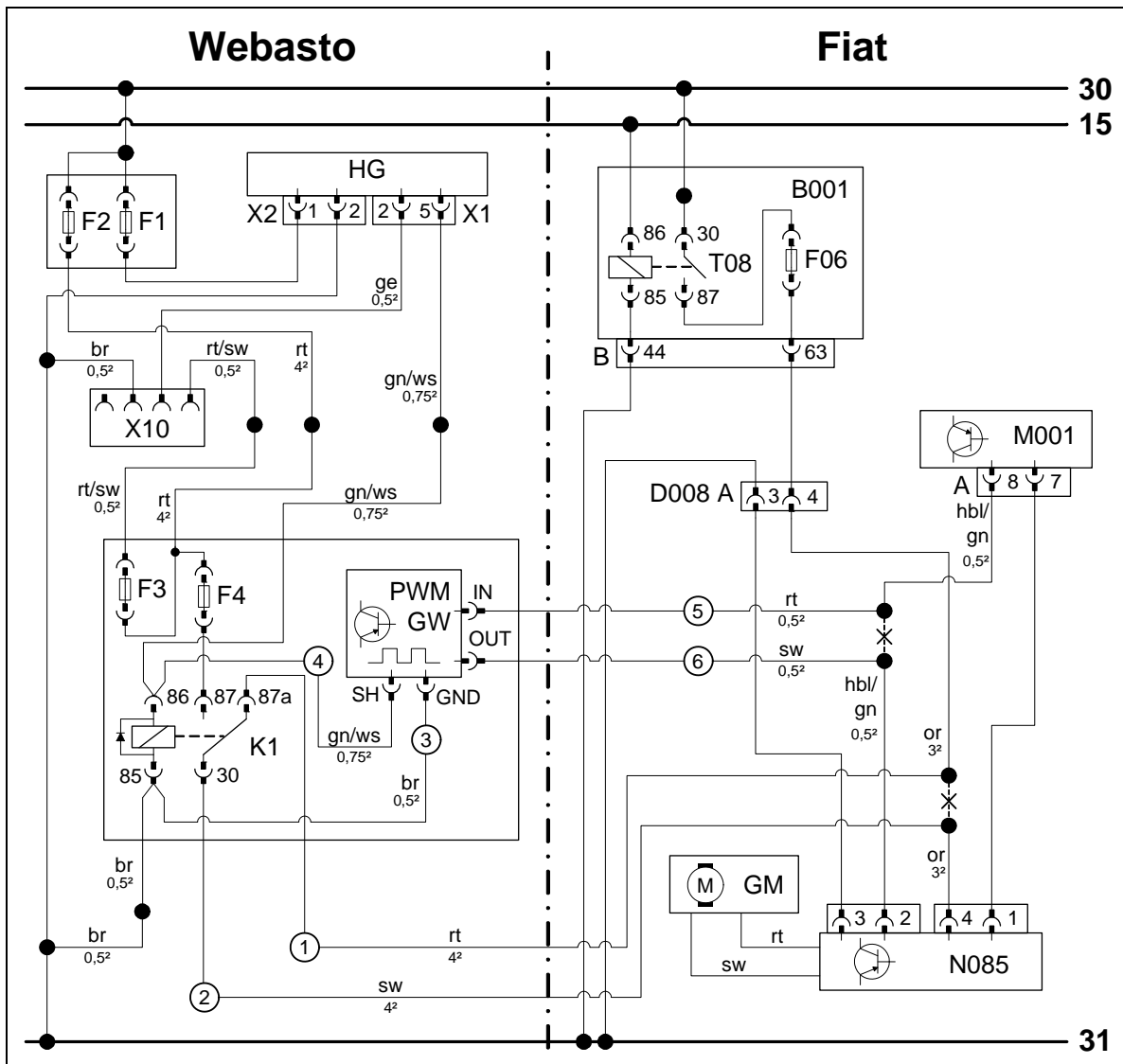

Wiring diagram

Webasto components		Vehicle components		Colours and symbols	
HG	TT-Evo Heater	B001	Central electrical box	rt	red
X1	6-pin heater connector	F06	30A fuse	sw	black
X2	2-pin heater connector	T08	Fan relay	ge	yellow
F1	20A fuse	B	Connector B001	gn	green
F2	30A fuse	M001	A/C control unit	or	orange
X10	4-pin connector of heater control	A	Connector M001	ws	white
F3	1A fuse	D008 A	Intermediate connector	br	brown
F4	25A fuse	GM	Fan motor	hbl	light blue
PWM-GW	Pulse width modulator Gateway	N085	Fan controller		
K1	Fan relay				
Settings of PWM-GW:					
Duty cycle: 25%					
Frequency: 1000Hz					
Voltage: 4.8V				X	Cutting point
Function: High side					Wiring colours may vary.

Legend

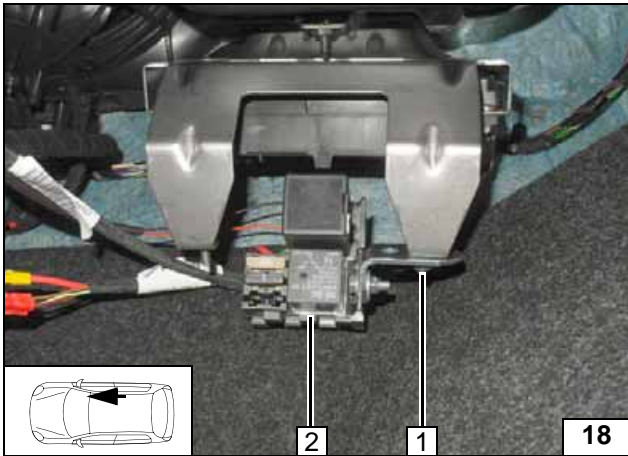
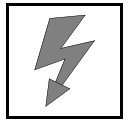

- 1 M5 flanged nut, premounted angle bracket, original vehicle stud bolt
- 2 Passenger compartment relay and fuse holder

Installing relay and fuse holder of passenger compartment

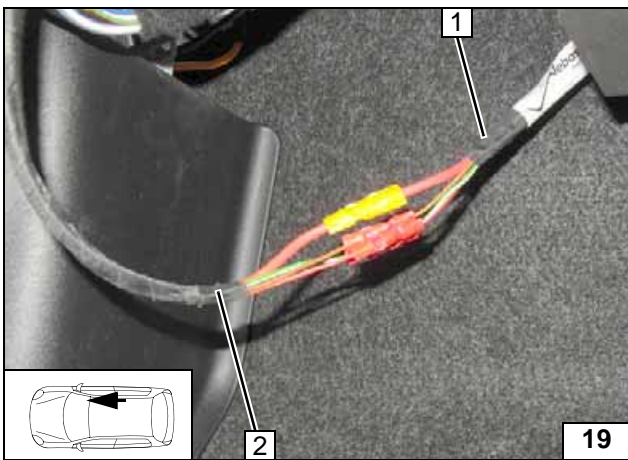

- 1 Wiring harness of passenger compartment relay and fuse holder
- 2 Wiring harness of heater

Connecting same colour wires of wiring harnesses

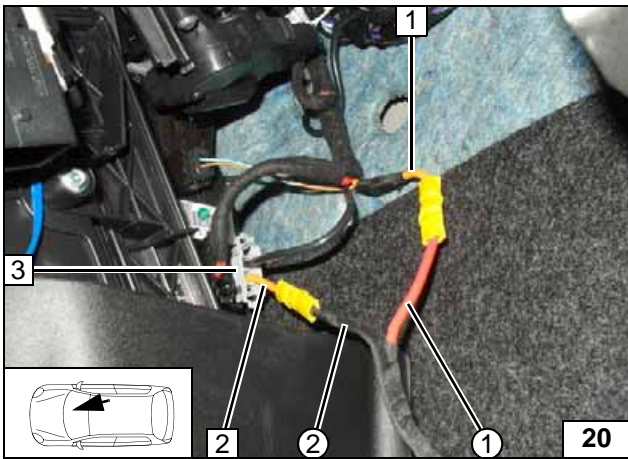

- 1 Orange (or) wire of connector D008 A/ pin 4
- 2 Orange (or) wire of fan controller connector/ pin 4
- 3 Fan controller connector
- ① Red (rt) wire from K1/87a, fan wiring harness
- ② Black (sw) wire from K1/30, fan wiring harness



Connecting fan controller

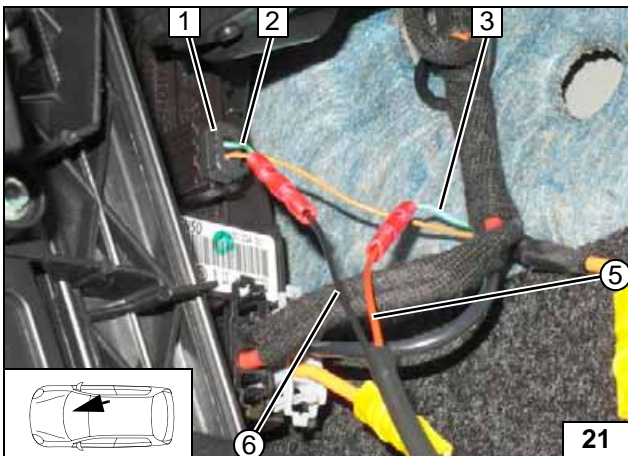

- 1 Fan controller connector
- 2 Light blue/green (hbl/gn) wire of fan controller connector/ pin 2
- 3 Light blue/green (hbl/gn) wire of A/C control unit connector A/ pin 8
- ⑤ Red (rt) wire of PWM GW/ IN
- ⑥ Black (sw) wire of PWM GW/ OUT

Connecting fan controller

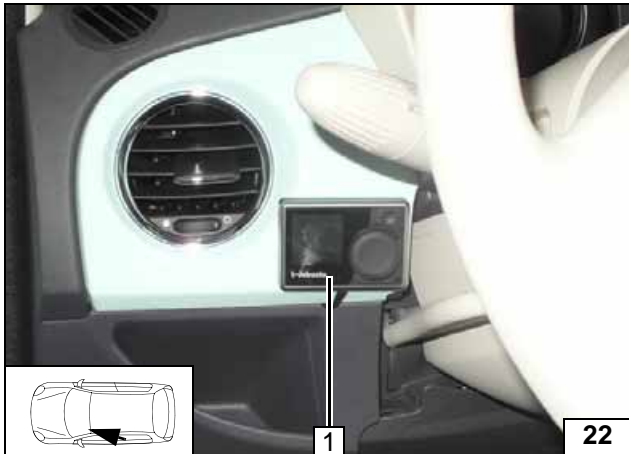

MultiControl CAR Option

- 1 MultiControl CAR



Installing
MultiControl
CAR

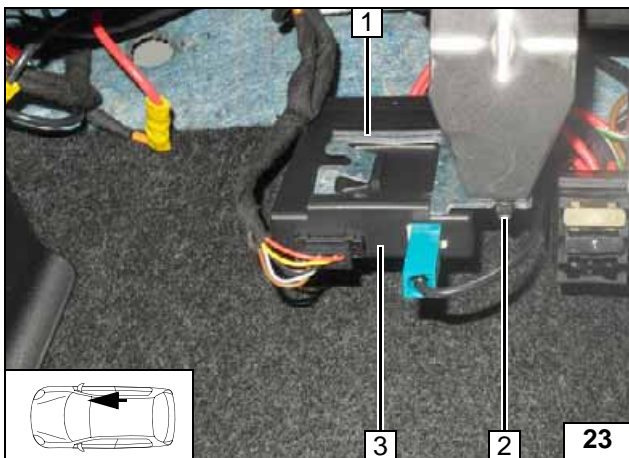

Remote Option (Telestart)

- 1 Bracket
- 2 M5 flanged nut on original vehicle stud bolt
- 3 Receiver



Installing
receiver

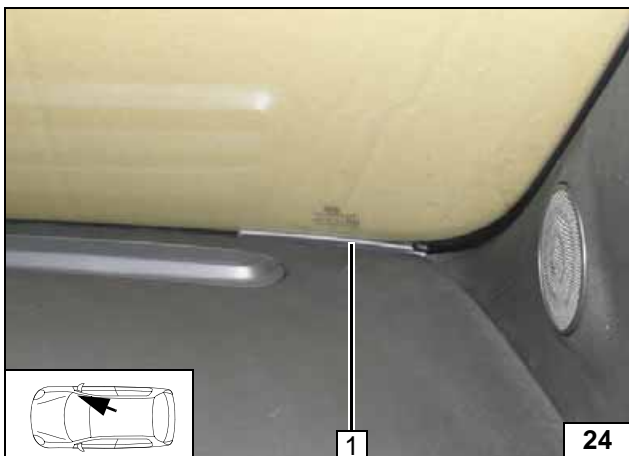

- 1 Antenna

Installing
antenna

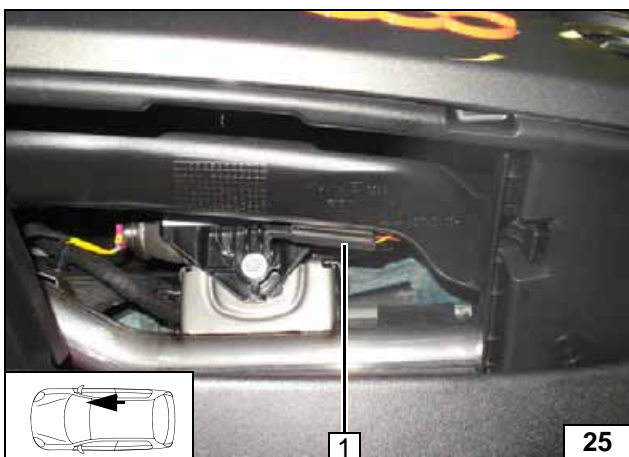

Temperature sensor T100 HTM

Fasten temperature sensor 1 with adhesive tape.



Installing
tempera-
ture sensor

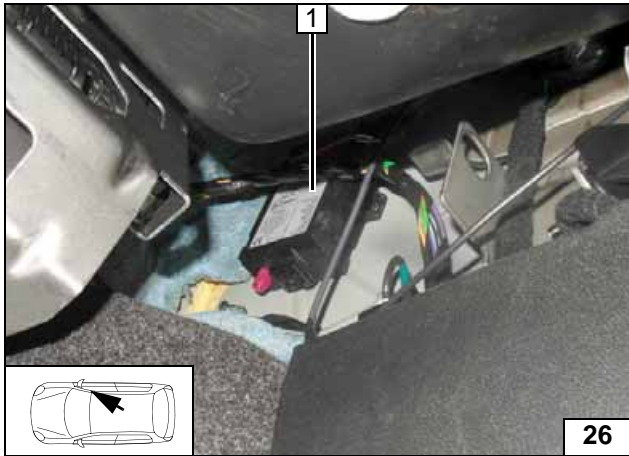
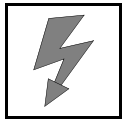

Thermo Call Option

Fasten Thermo Call receiver 1 with adhesive tape!

Installing receiver

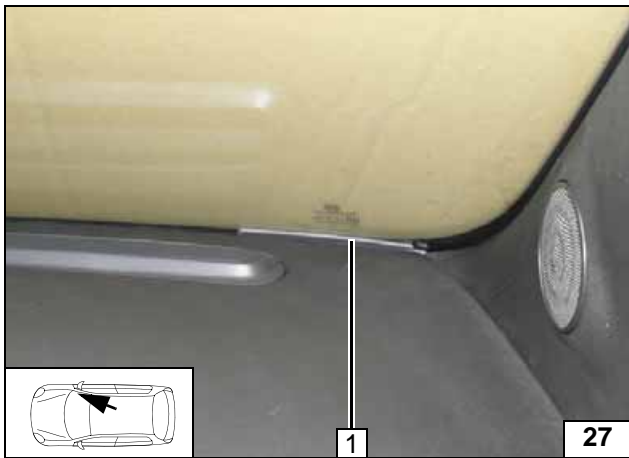

1 Antenna

Installing antenna

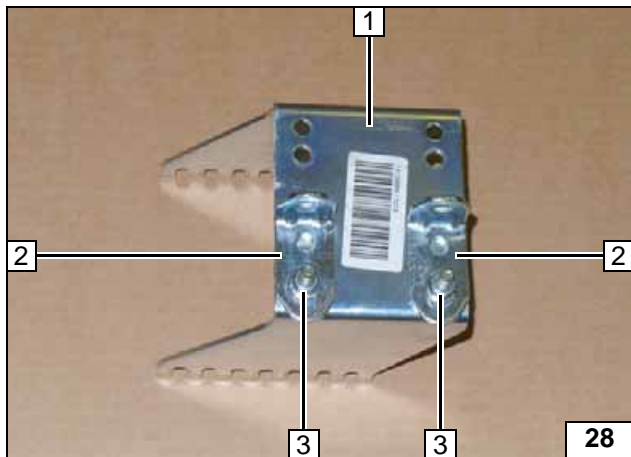

Preparing Installation Location

- 1 Bracket
- 2 Angle bracket [2x]
- 3 M6x20 bolt, flanged nut [2x each]

Premounting bracket

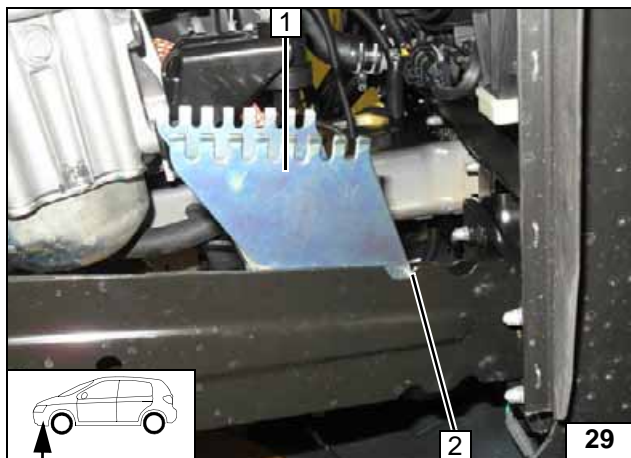

Place bracket 1 at recess edge as shown.



Placing bracket

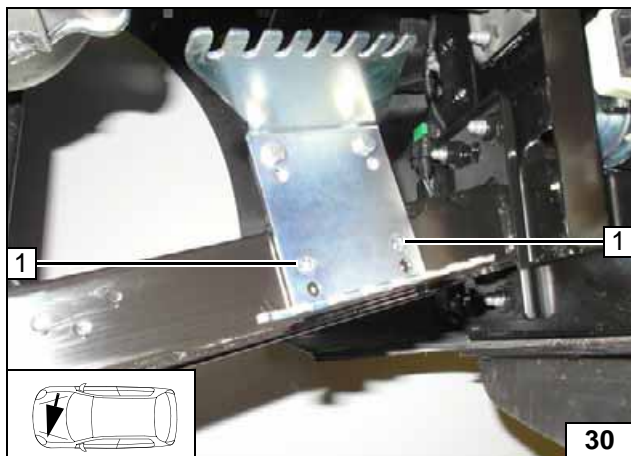

- 1 Copy hole pattern of bracket [2x]

Copying hole pattern

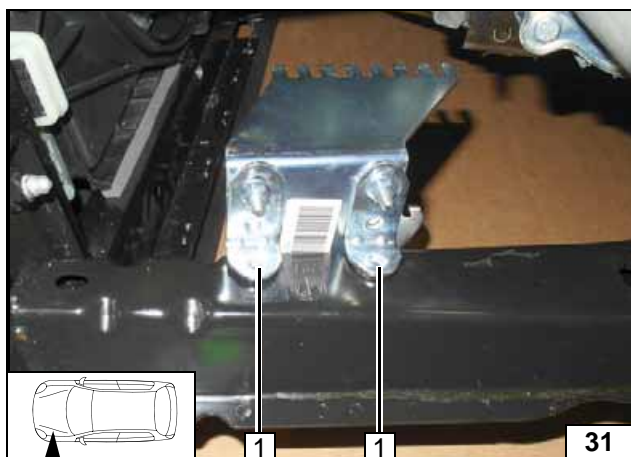

- 1 Copy hole pattern of angle bracket [2x]

Copying hole pattern

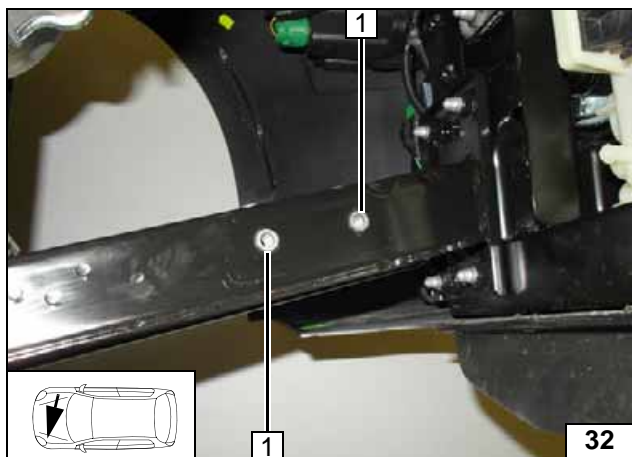

1 9.1 mm dia. hole, rivet nut [2x]

Installing rivet nut

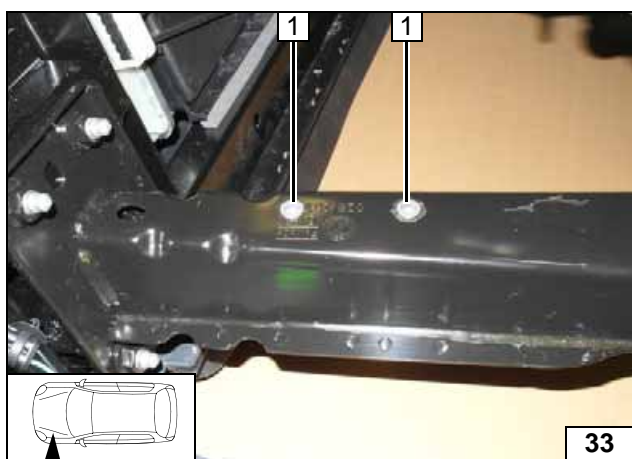

1 9.1 mm dia. hole, rivet nut [2x]

Installing rivet nut

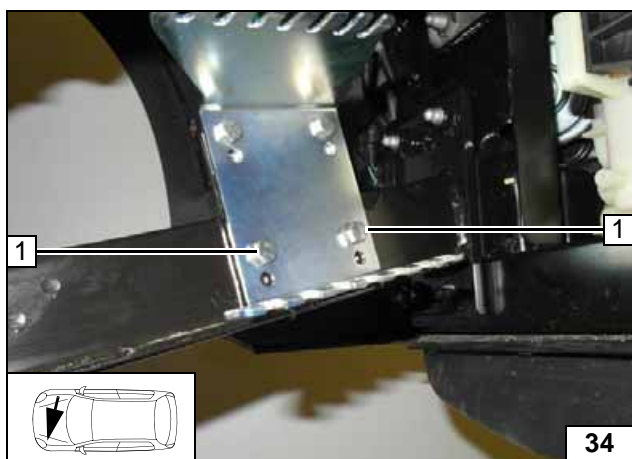

1 M6x20 bolt, spring lockwasher [2x each]

Installing bracket

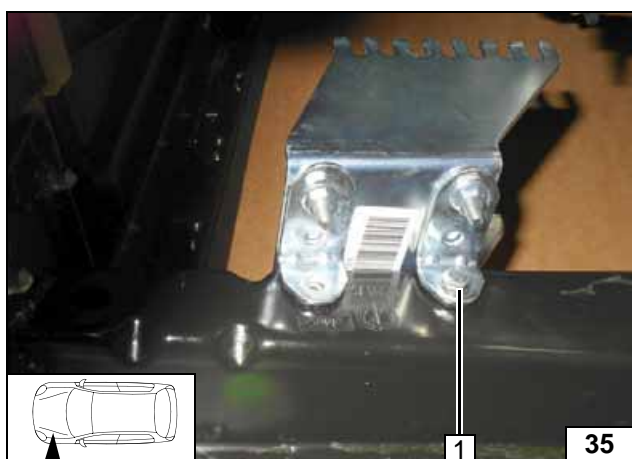

1 M6x20 bolt, spring lockwasher

Installing bracket

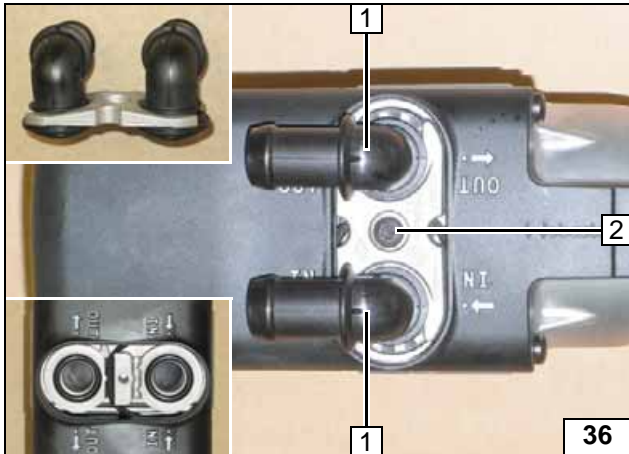
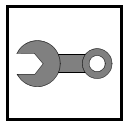

Preparing Heater

- 1 Water connection piece, sealing ring [2x each]
- 2 5x15 self-tapping bolt, retaining plate of water connection pieces



Installing water connection pieces

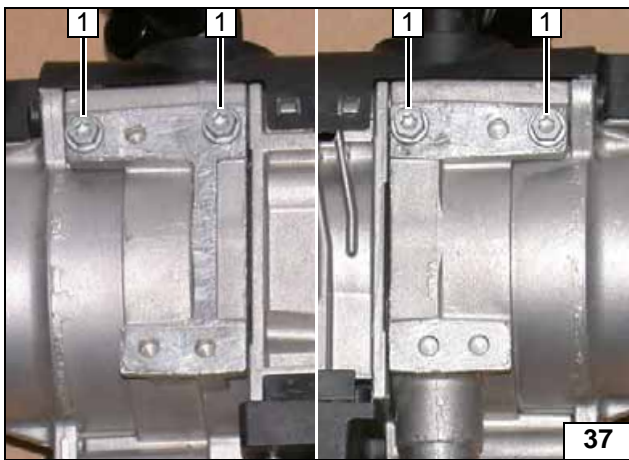

Screw 5x13 self-tapping bolts 1 [4x] into existing holes by a maximum of 3 thread turns.



Premounting bolts loosely

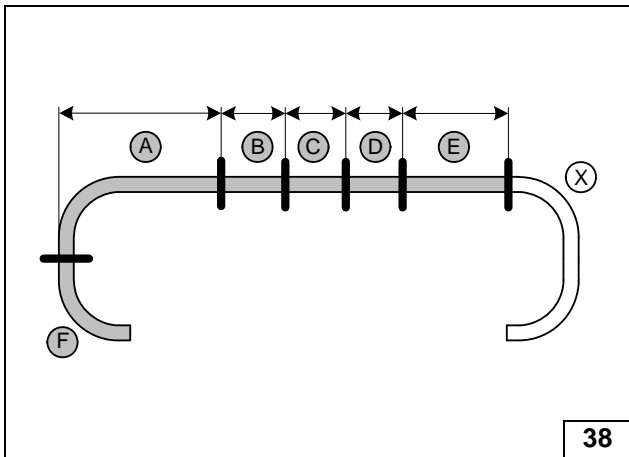

0.9 P

Discard section X.

- A = 410
- B = 90
- C = 100
- D = 70
- E = 480



Cutting hoses to length

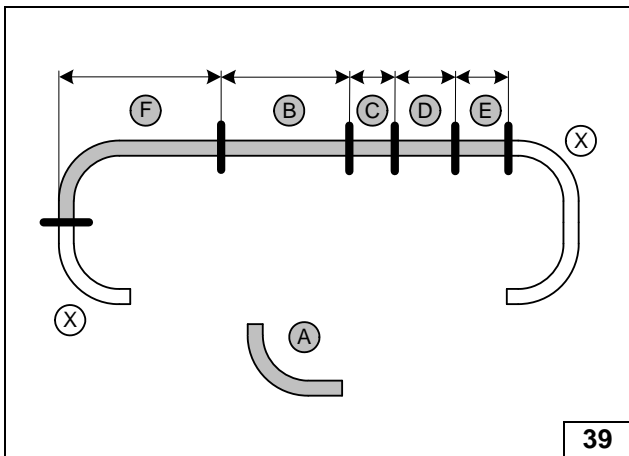

1.2 P

Discard sections X.

Hose A = 15x18mm dia., 90° moulded hose

- B = 510
- C = 90
- D = 100
- E = 70
- F = 510



Cutting hoses to length

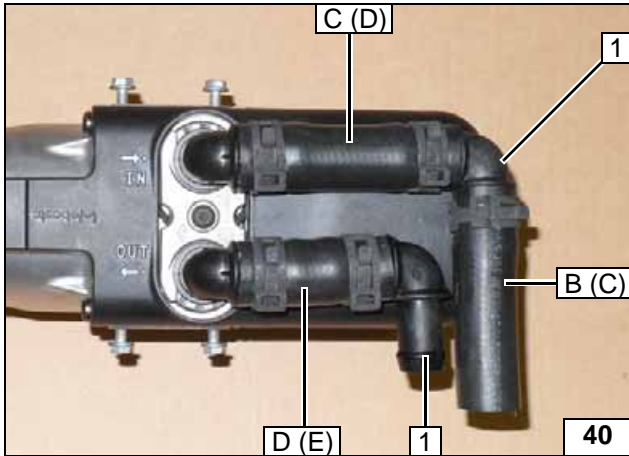
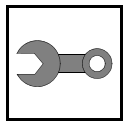

All vehicles

Specifications in brackets apply for 1.2 P!

All spring clips = 25 mm dia.

- 1 18 x 18 mm dia. connecting pipe [2x]

Premounting hoses

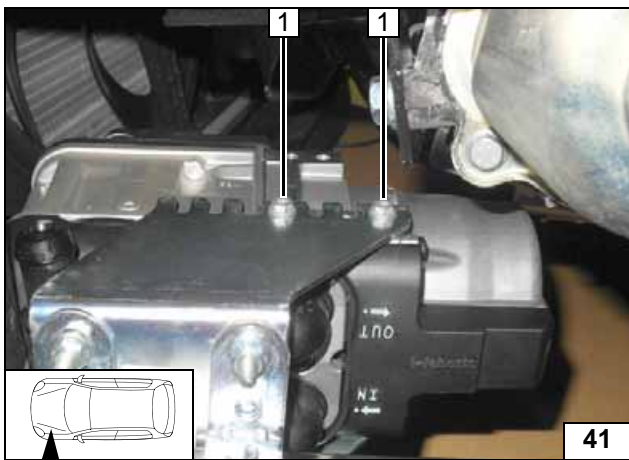

Installing Heater

- 1 Tighten 5x13 self-tapping bolt [2x]

Installing heater

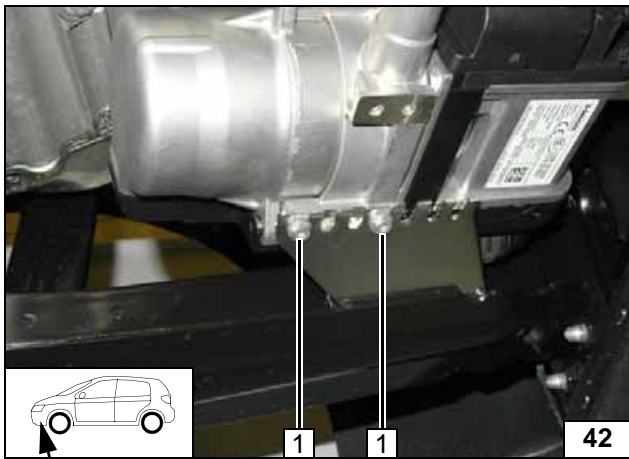

- 1 Tighten 5x13 self-tapping bolt [2x]

Installing heater

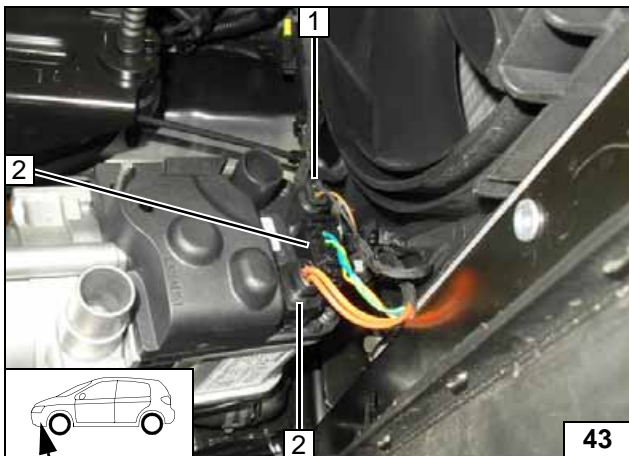

- 1 Connector of circulating pump wiring harness
- 2 Connector of heater wiring harness [2x]

Mounting wiring harness

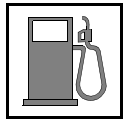

Fuel

CAUTION!

Open the vehicle's fuel tank cap, ventilate the tank and then re-close the tank lock.

Catch any fuel running off in an appropriate container.

Install fuel line and metering pump wiring harness so that they are protected against stone impact. Unless specified otherwise, always fasten using cable ties. Provide rub protection for fuel line and wiring harness in areas where there are sharp edges.

WARNING!

The fuel line and wiring harness are routed to the metering pump as shown in the wiring harness routing diagram.

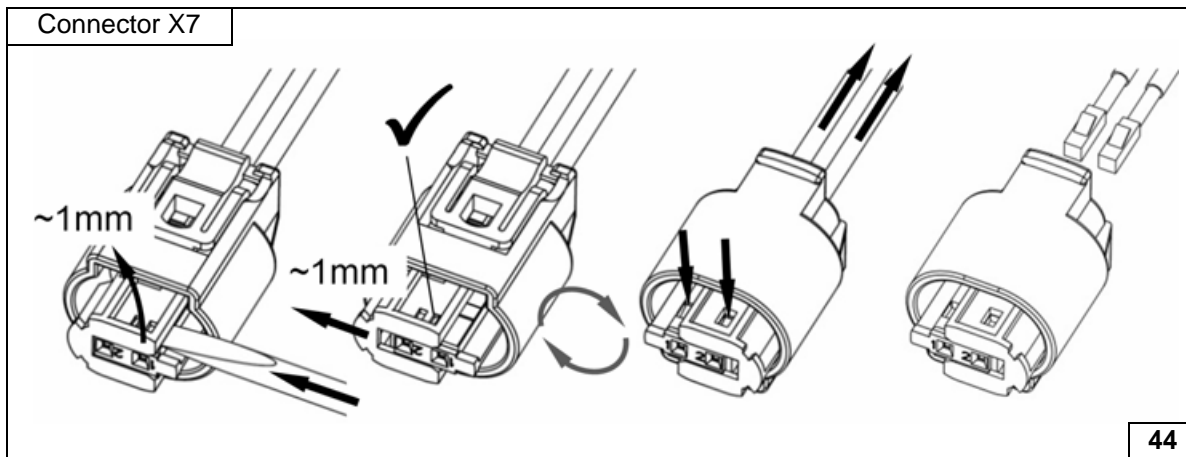

Removing metering pump connector

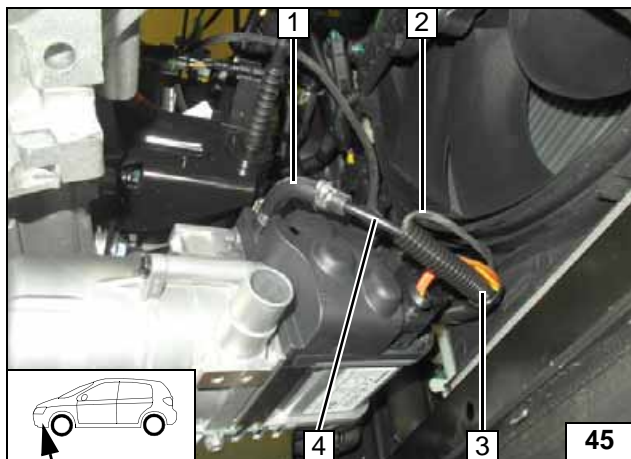

Pull fuel line 4 and wiring harness of metering pump 2 into 10mm dia. corrugated tube 3.

- 1 90° moulded hose, 10mm dia. clamp [2x]



Connecting heater

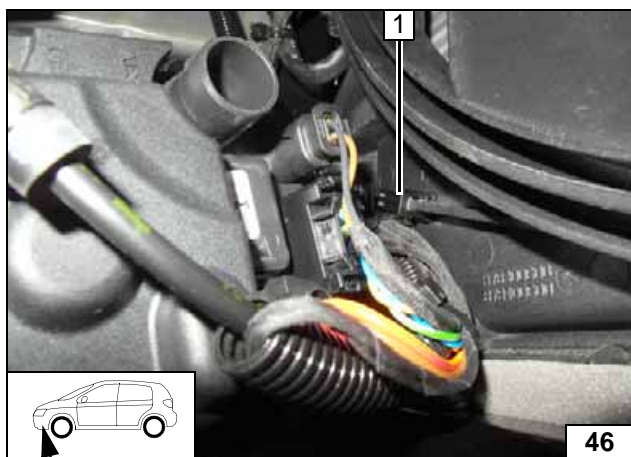

- 1 Install retaining clip on radiator trim edge

Installing retaining clip

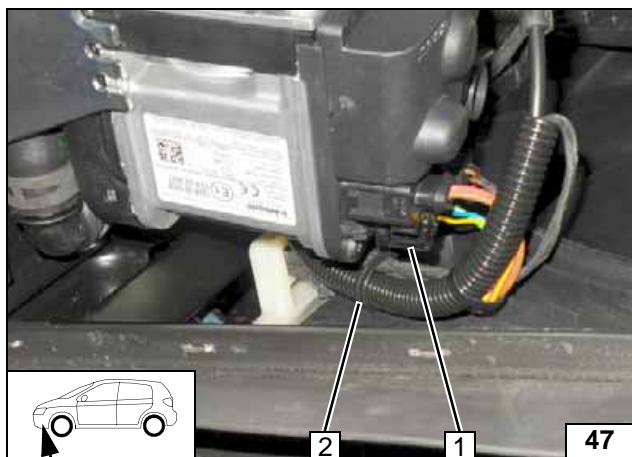
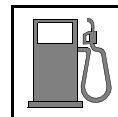

- 1 Retaining clip
- 2 Close cable tie

Fastening wiring harnesses and corrugated tube

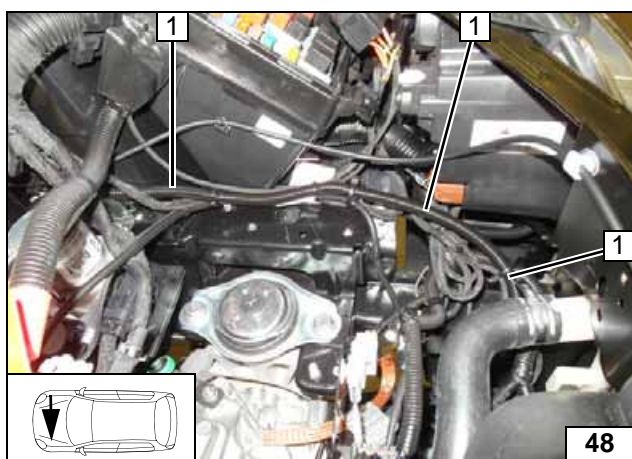

Route fuel line and wiring harness of metering pump in 10mm dia. corrugated tube 1 to firewall and further along original vehicle lines to underbody.

Routing lines



Route fuel line and wiring harness of metering pump in 10 mm dia. corrugated tube 1 to installation location of the metering pump.

Routing lines

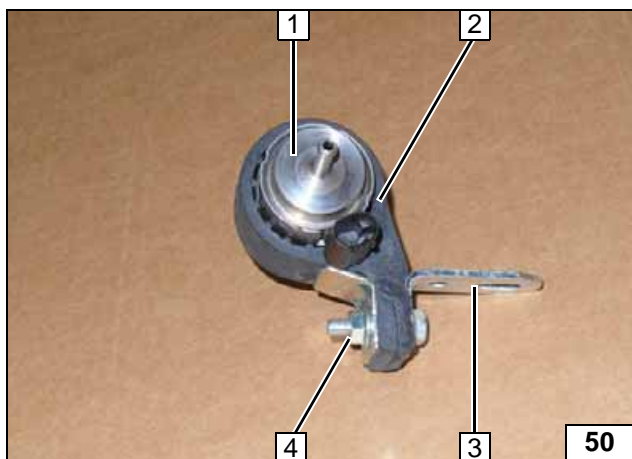

- 1 Metering pump
- 2 Mounting of metering pump
- 3 Angle bracket
- 4 M6x25 bolt, support angle bracket, flanged nut

Premounting metering pump

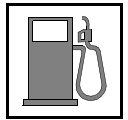

Installing metering pump

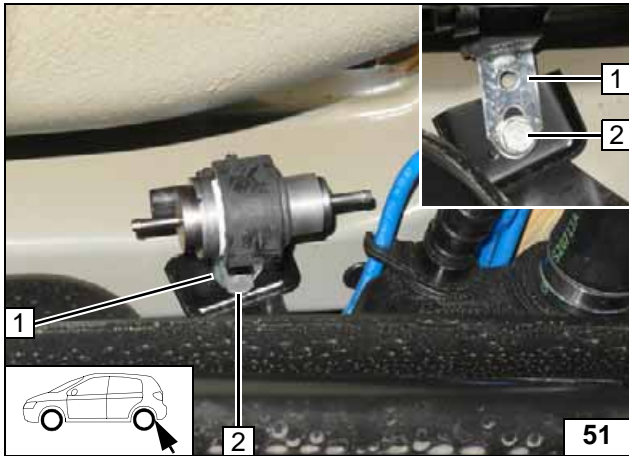

- 1 Angle bracket
- 2 Original vehicle bolt

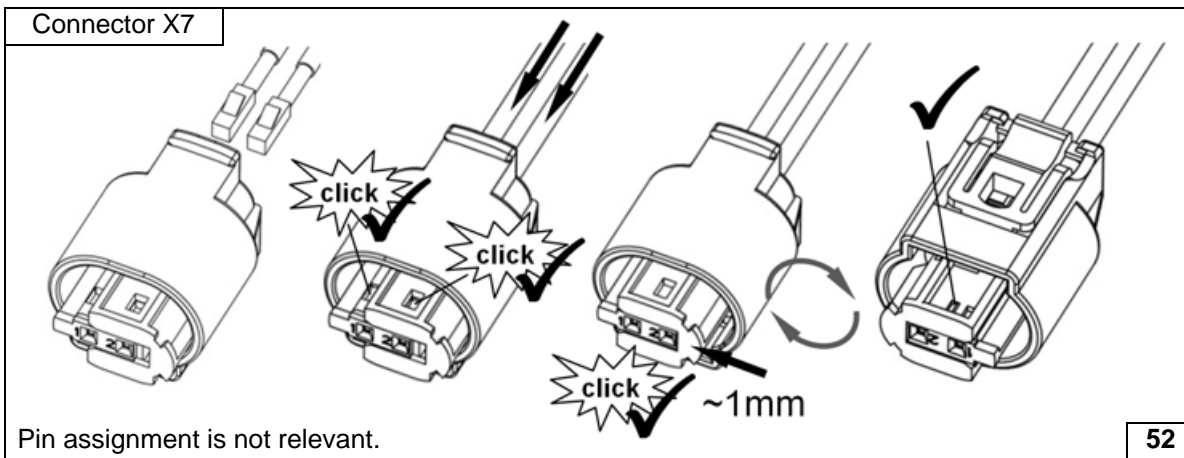

Completing metering pump connector

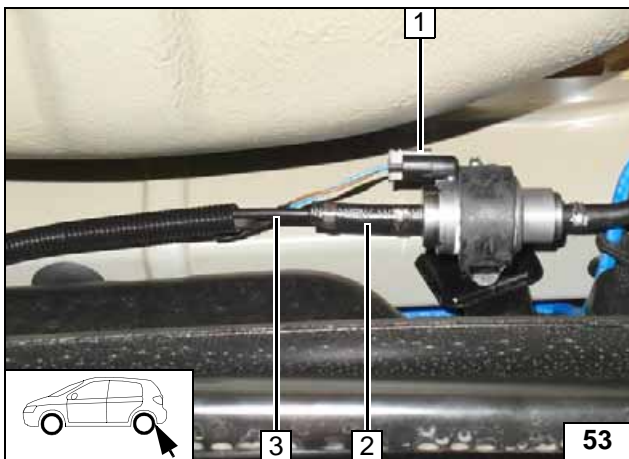

- 1 Wiring harness of metering pump, connector X7 mounted
- 2 Hose section, 10mm dia. clamp [2x]
- 3 Fuel line of heater



Connecting metering pump

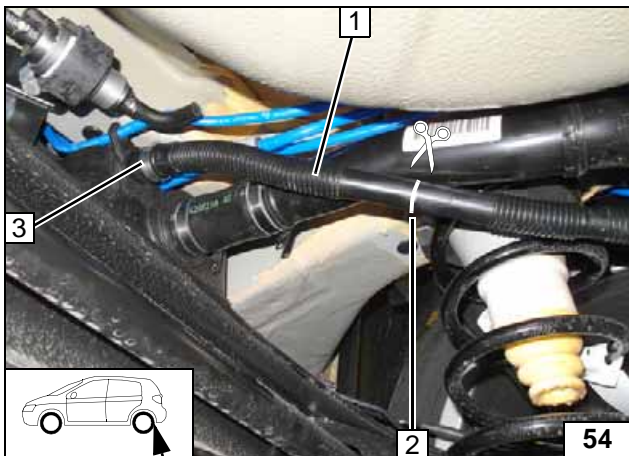

Cut fuel-tank vent line at marking. Remove ventilation line 1, will be reused. Discard clamp 3.

- 2 Cutting point



Fuel extraction

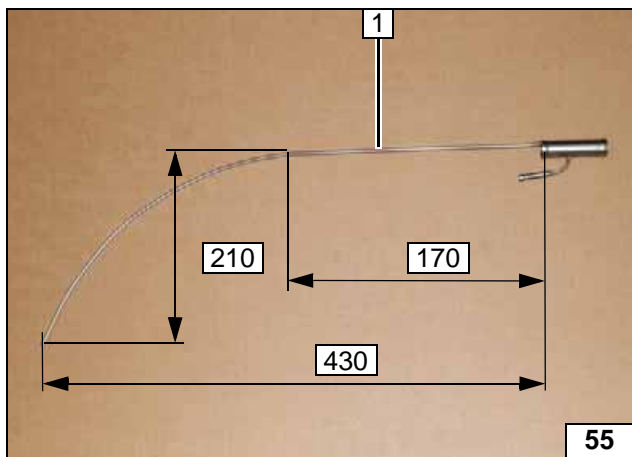
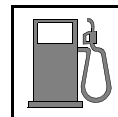

Bend fuel standpipe 1 as shown and cut it to length.



Preparing fuel standpipe

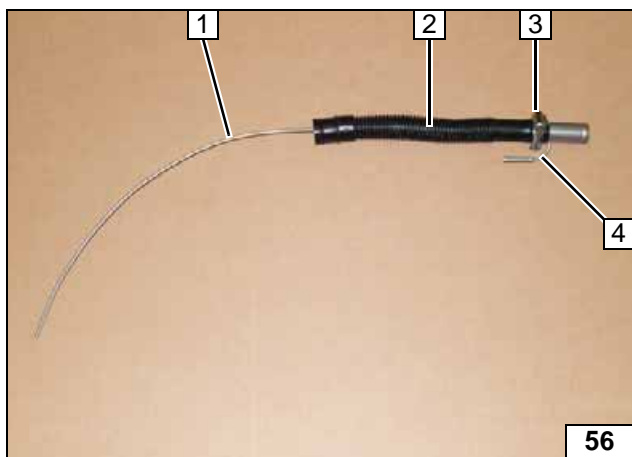

Angle down standpipe by 90° at position 4 as shown.



- 1 Fuel standpipe
- 2 Ventilation pipe
- 3 16-24 mm dia. clamp

Premounting fuel standpipe

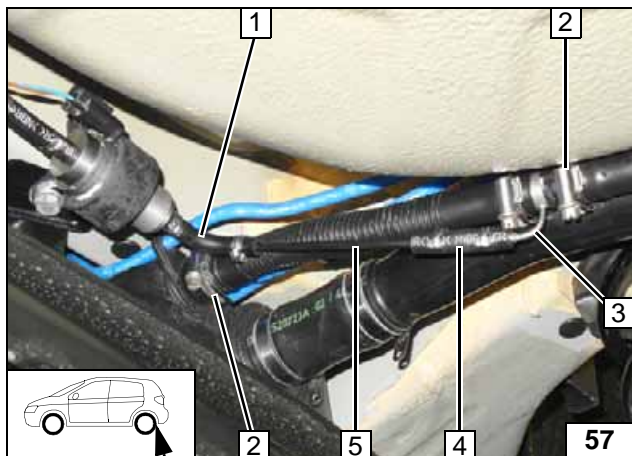

Ensure sufficient distance from neighbouring components, correct if necessary.



- 1 90° moulded hose, 10mm dia. clamp [2x]
- 2 16-24 mm dia. clamp [2x]
- 3 Fuel standpipe
- 4 Hose section, 10mm dia. clamp [2x]
- 5 Fuel line of fuel standpipe

Connecting metering pump



Coolant Circuit for 0.9 P (Island)

WARNING!

Any coolant running off should be collected in an appropriate container. Install hoses so that they are kink-free. Unless specified otherwise, always fasten using cable ties. Position clamps so that other hose cannot be damaged. When installing the hoses, the heater must be filled with coolant.



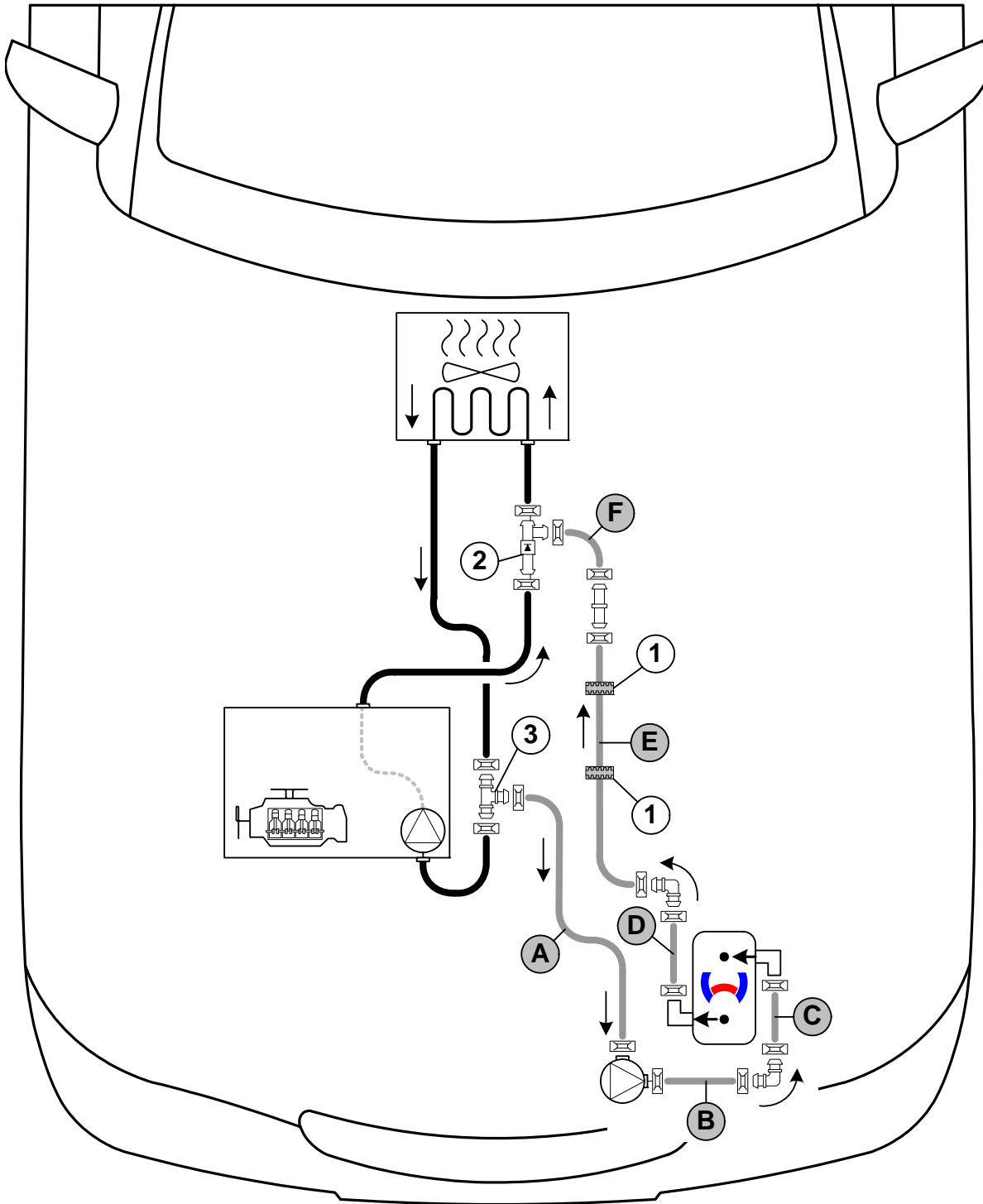

The connection should be modelled on an "island" circuit and based on the following diagram:



Hose routing diagram

All spring clips  = 25 mm dia. All connecting pipes  and  = 18x18 mm dia.

1 = Black (sw) rubber isolator .

2 = Check valve .

3 = T-piece .



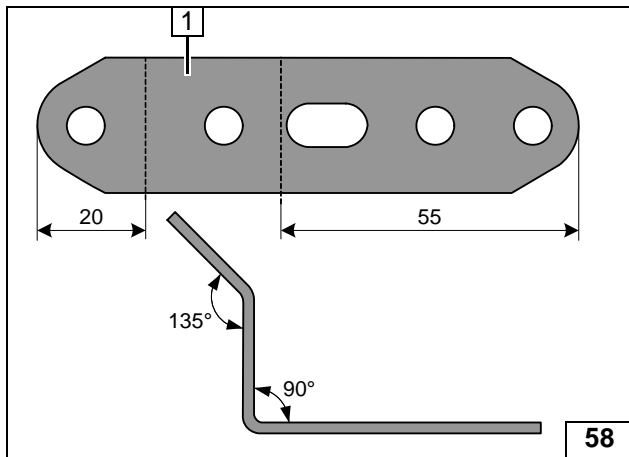

1 Perforated bracket



Preparing perforated bracket

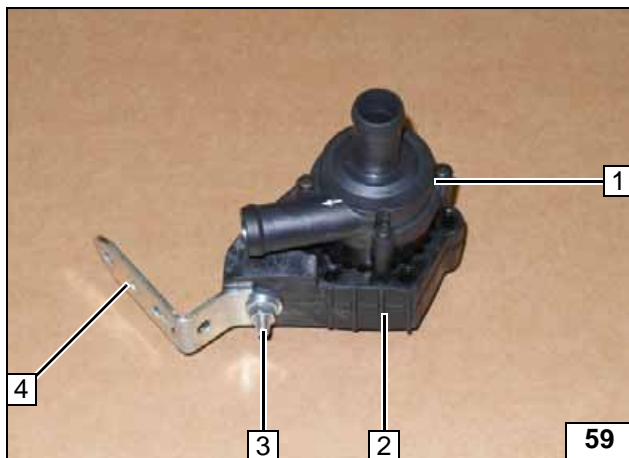

- 1 Circulating pump
- 2 Circulating pump mounting
- 3 M6x25 bolt, flanged nut
- 4 Perforated bracket

Premounting circulating pump

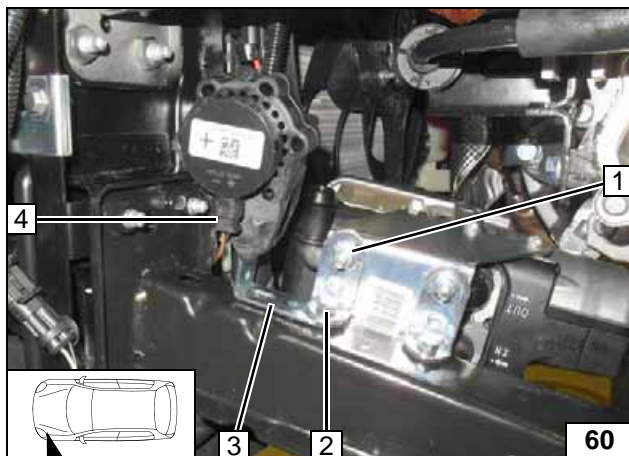

Mount perforated bracket of circulating pump 3 between frame side member and angle bracket. Tighten bolt 1.



- 2 M6x20 bolt, spring lockwasher
- 4 Connector of circulating pump wiring harness

Installing circulating pump

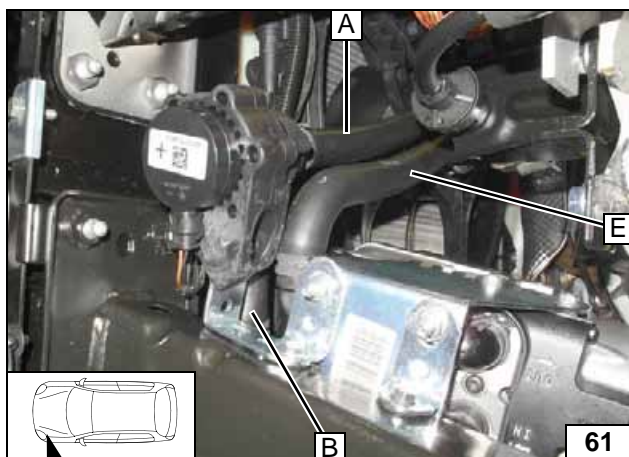

Connecting circulating pump and heater outlet

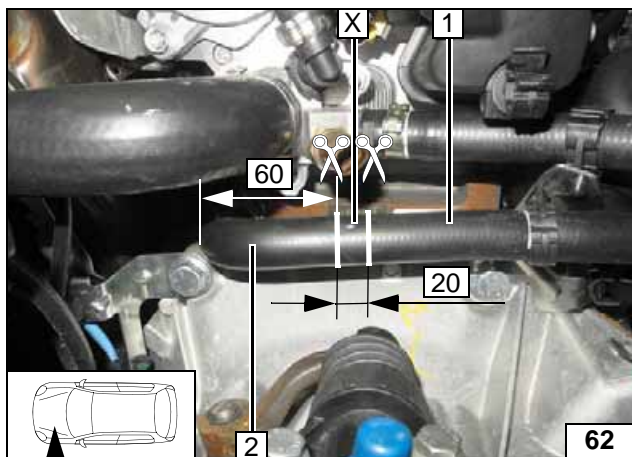

Discard section X.

- 1 Hose section of heat exchanger outlet
- 2 Hose section of engine inlet



Cutting point for hose of heat exchanger outlet

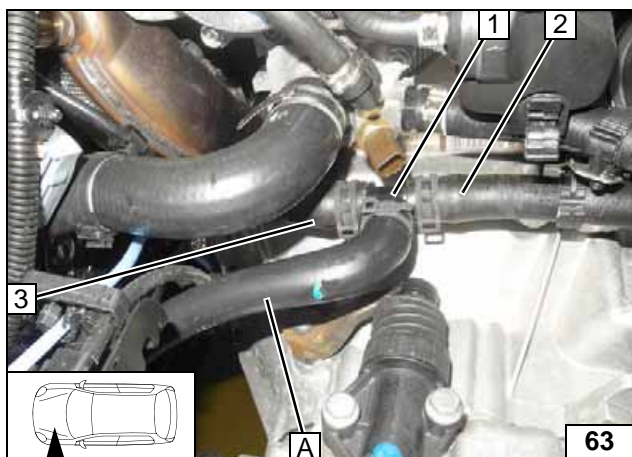

- 1 T-piece
- 2 Hose section of heat exchanger outlet
- 3 Hose section of engine inlet

Connection on engine inlet

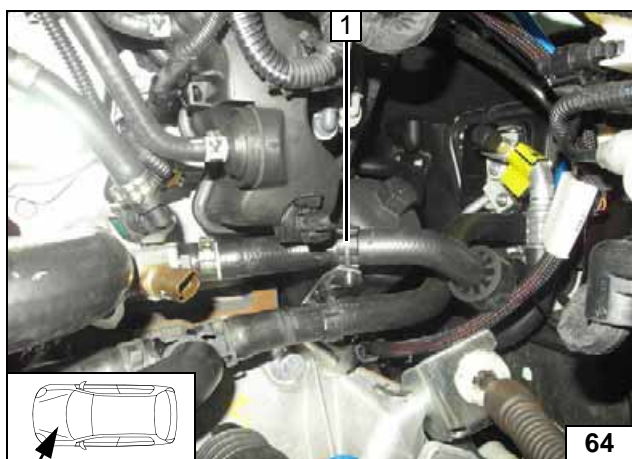

- 1 Discard original vehicle hose bracket

Removing hose bracket

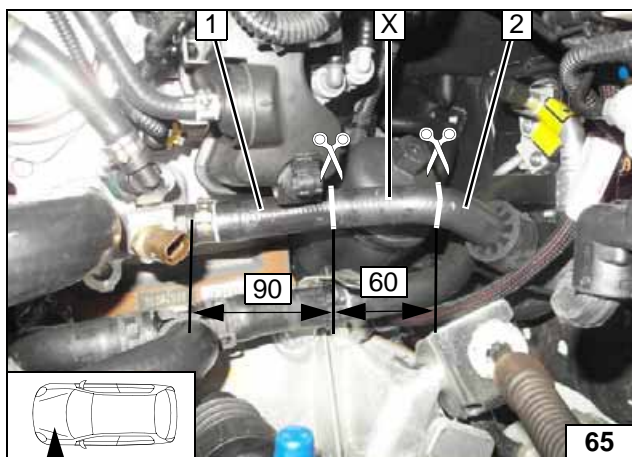

Discard section X.

- 1 Hose section of engine outlet
- 2 Hose section of heat exchanger inlet



Cutting point for hose of heat exchanger inlet

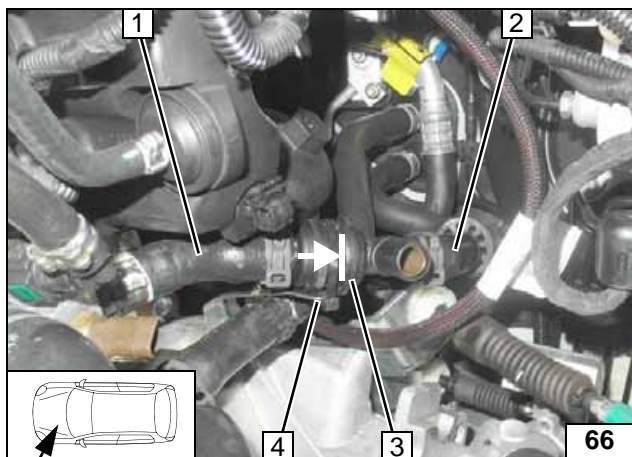

Observe flow direction!

- 1 Hose section of engine outlet
- 2 Hose section of heat exchanger inlet
- 3 Check valve
- 4 Cable tie on original vehicle retaining plate



Installing check valve

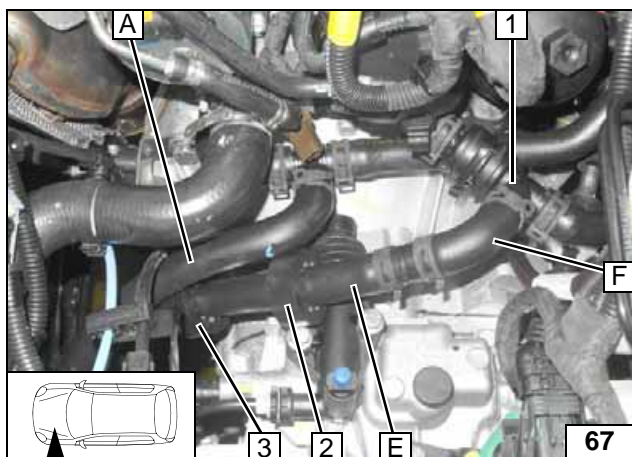

Align hoses. Ensure sufficient distance from neighbouring components, correct if necessary.

- 1 Check valve
- 2 Align black (sw) rubber isolator with clutch cylinder
- 3 Align black (sw) rubber isolator with transmission housing



Connection on check valve

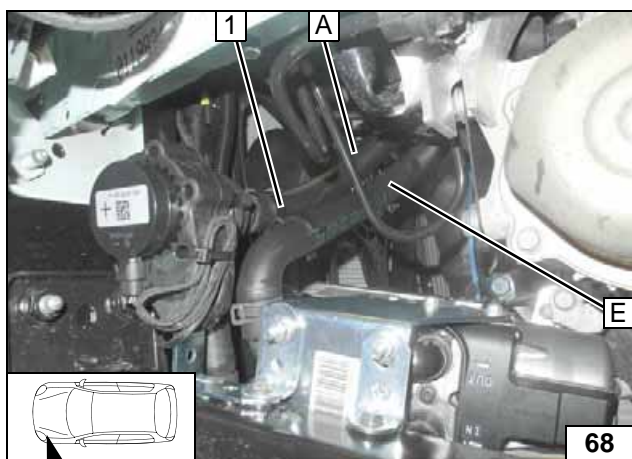

- 1 Hose bracket

Mounting hose bracket





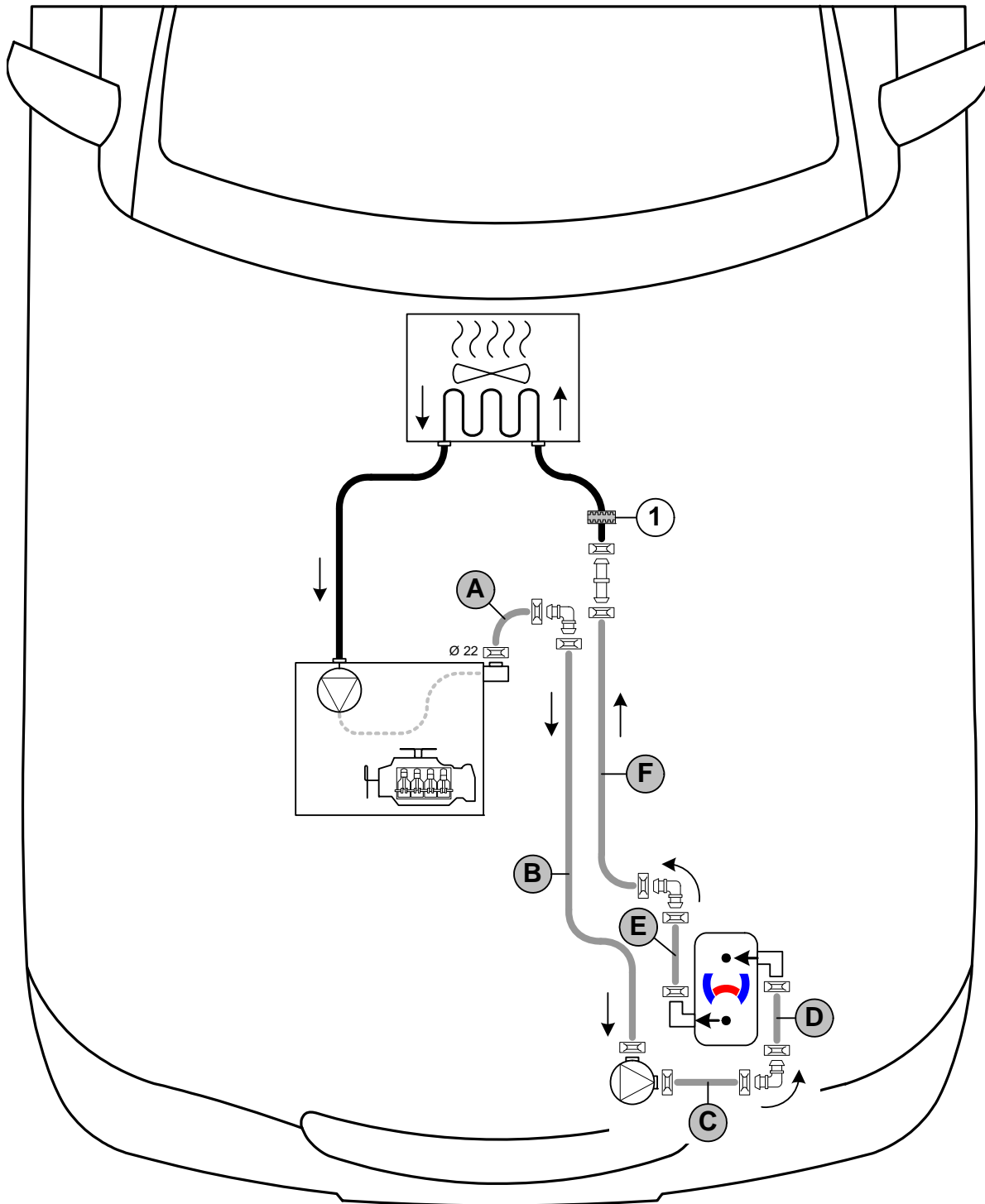

Coolant Circuit for 1.2 P

WARNING!

Any coolant running off should be collected in an appropriate container. Install hoses so that they are kink-free. Unless specified otherwise, always fasten using cable ties. Position clamps so that other hose cannot be damaged. When installing the hoses, the heater must be filled with coolant. The connection should be modelled on an "inline" circuit and based on the following diagram:



Hose routing diagram

All spring clips without specific designation  = 25mm dia.
 1 = Black (sw) rubber isolator .
 All connecting pipes  and  = 18x18 mm dia.



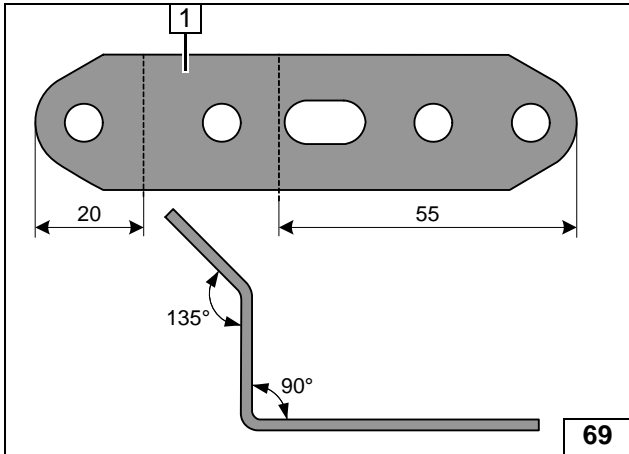

1 Perforated bracket



Preparing perforated bracket

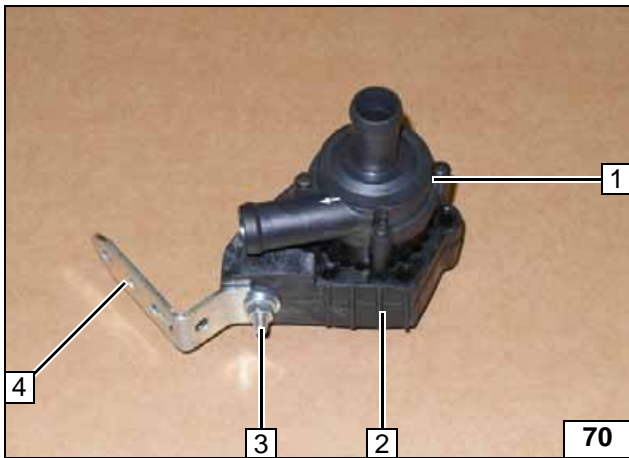

- 1 Circulating pump
- 2 Circulating pump mounting
- 3 M6x25 bolt, flanged nut
- 4 Perforated bracket

Premounting circulating pump

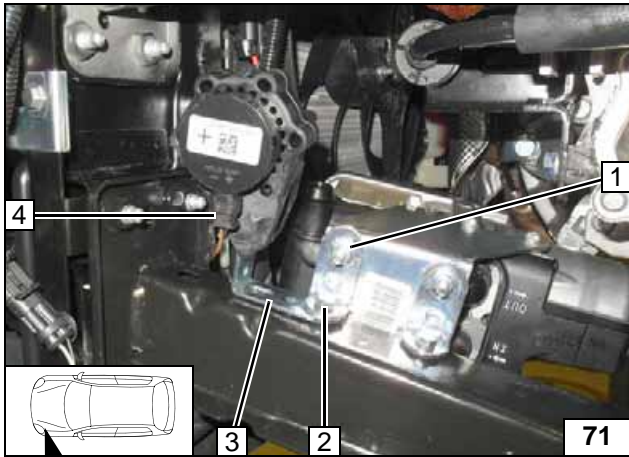

Mount perforated bracket of circulating pump 3 between frame side member and angle bracket.
Tighten bolt 1.



- 2 M6x20 bolt, spring lockwasher
- 4 Connector of circulating pump wiring harness

Installing circulating pump

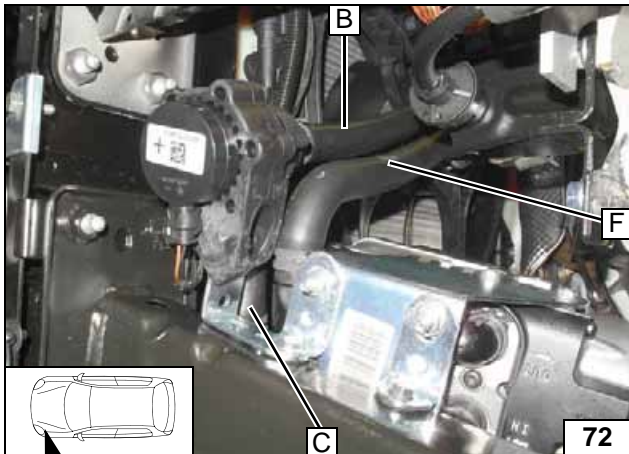

Connecting circulating pump and heater outlet

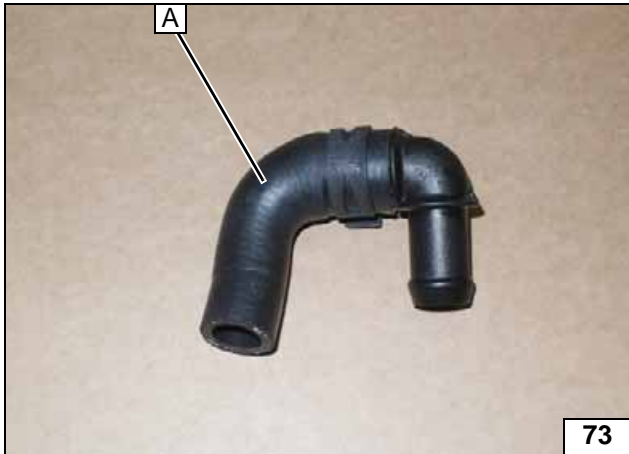

90° moulded hose **A** with 18mm dia. side on 18x18mm dia. connecting pipe



Premounting hose A

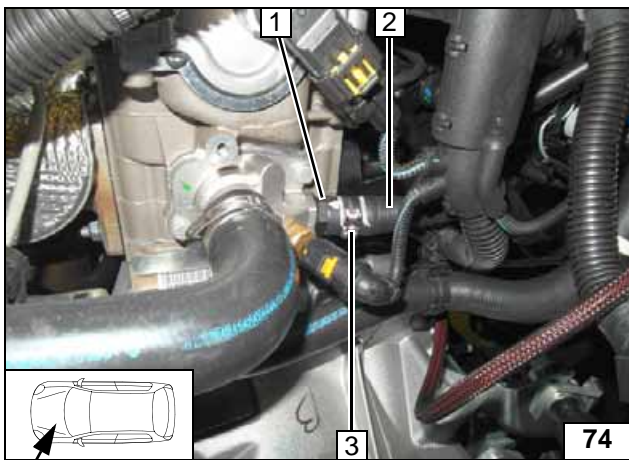

Pull hose to engine outlet / heat exchanger inlet **2** off connection piece of engine outlet **1**. Discard clamp **3**.



Cutting point

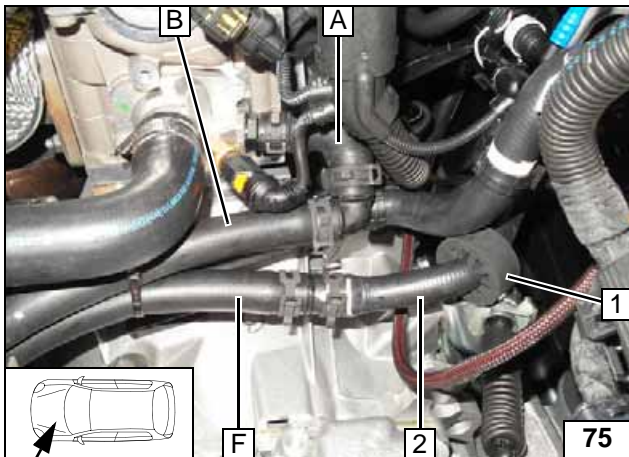

- 1 Align black (sw) rubber isolator with bracket of gearshift cable
- 2 Hose of heat exchanger inlet

Connecting engine outlet and heat exchanger inlet

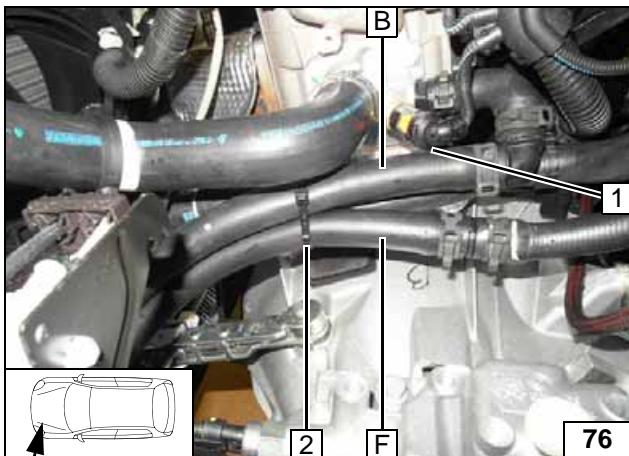

Align hoses. Ensure sufficient distance from connector of temperature sensor at position **1**, correct if necessary.



- 2 Cable tie

Aligning hoses

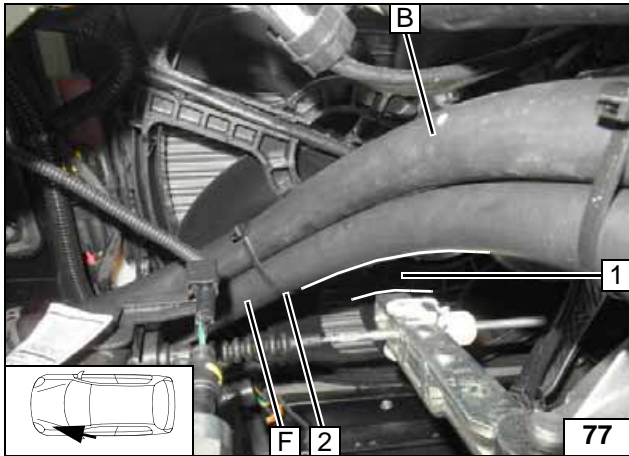

Align hoses. Ensure sufficient distance from clutch actuator at position 1, correct if necessary.

2 Cable tie

Routing in engine compartment

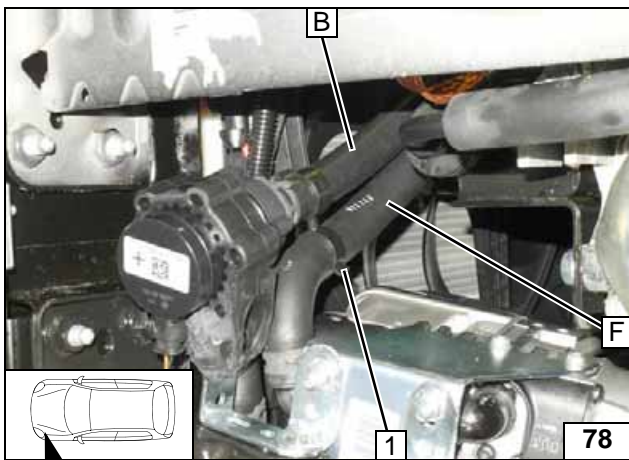

1 Hose bracket

Mounting hose bracket

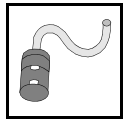

Combustion Air

- 1 Twist perforated bracket on its longitudinal axis by 90°

Preparing perforated bracket

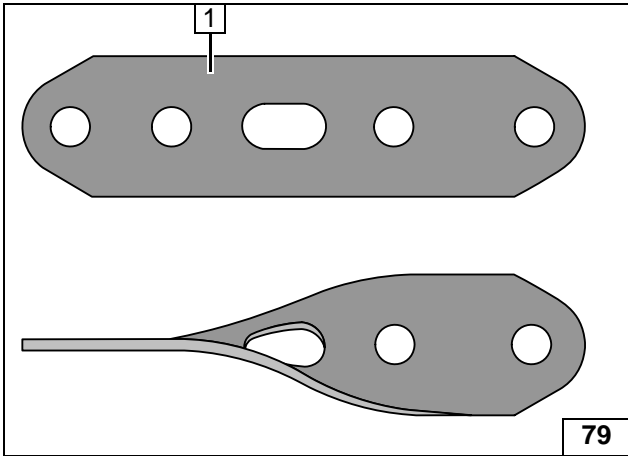

- 1 Combustion air pipe

Installing combustion air pipe

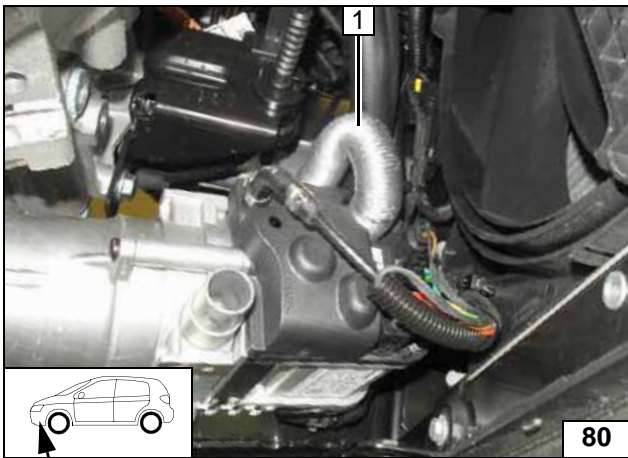

- 1 Original vehicle bolt
- 2 Perforated bracket
- 3 M5x16 bolt, flanged nut
- 4 Combustion air pipe
- 5 51 mm dia. clamp
- 6 Silencer



Installing silencer

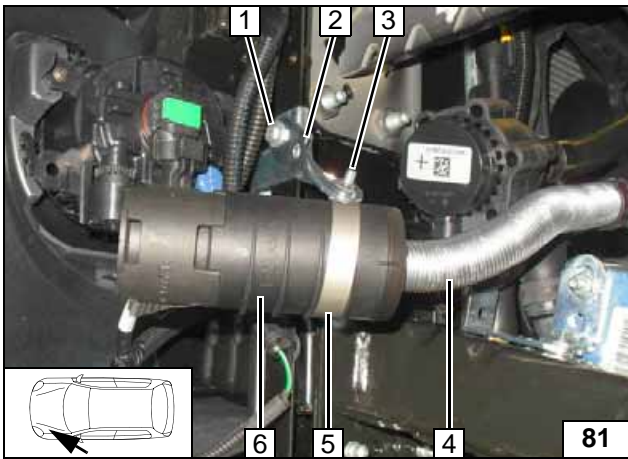

- 1 Hose bracket on hose
- 2 Combustion air pipe

Fastening combustion air pipe

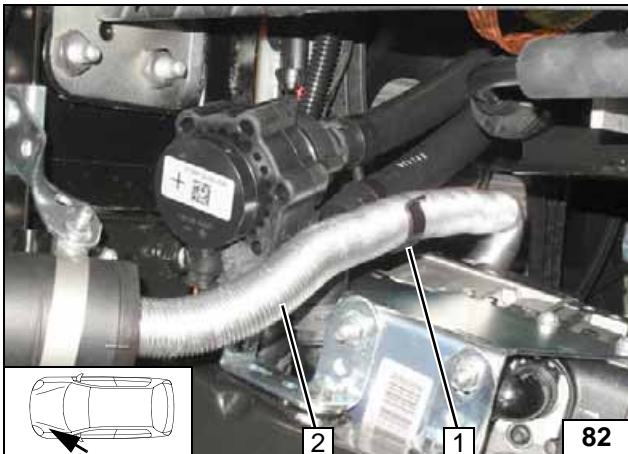

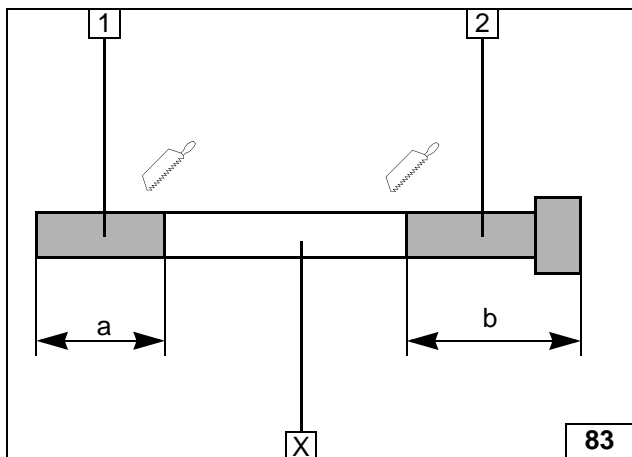
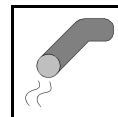

Exhaust Gas

Discard section X.

- 1 Exhaust pipe
a = 70
- 2 Exhaust end section
b = 150

Preparing exhaust pipe

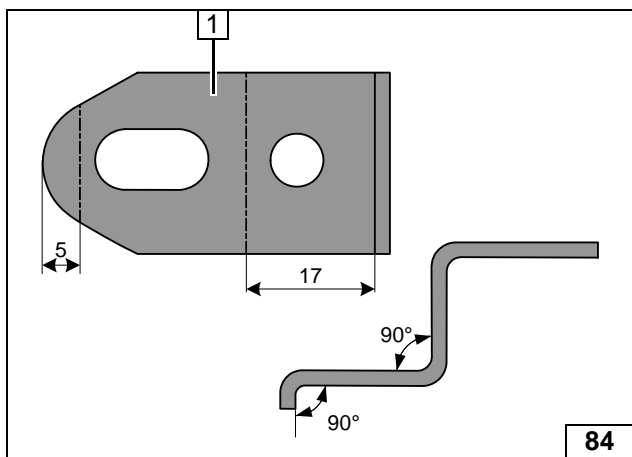

- 1 Angle bracket

Preparing angle bracket

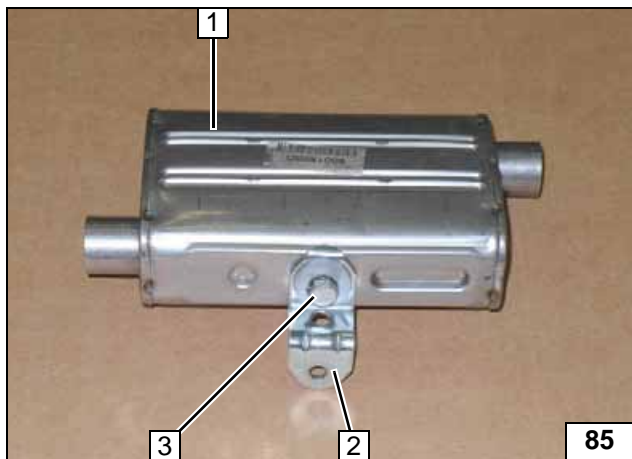

- 1 Silencer
- 2 Angle bracket
- 3 M6x16 bolt, large diameter washer, spring lockwasher

Installing silencer

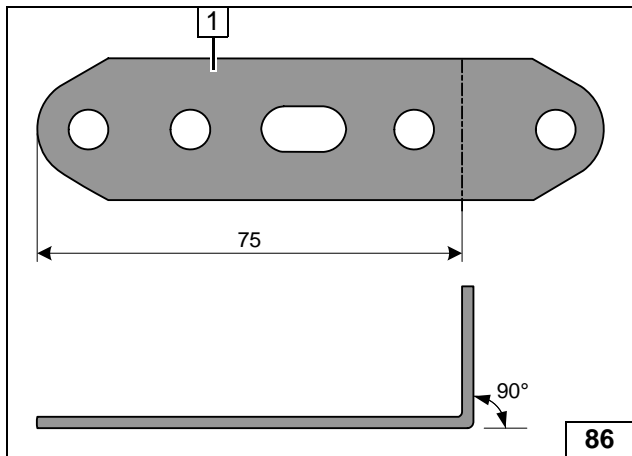

- 1 Perforated bracket

Preparing perforated bracket

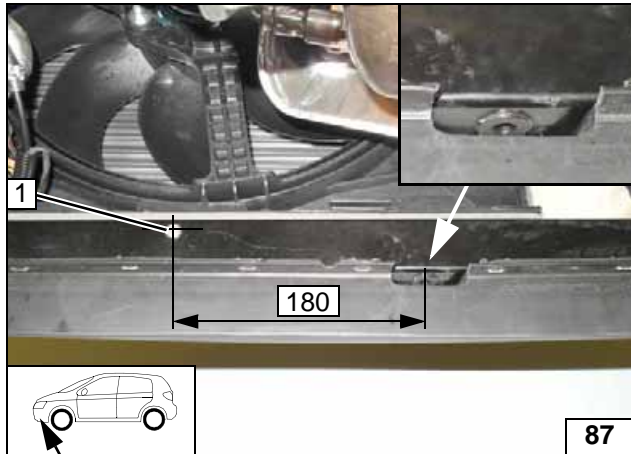
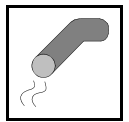

1 9.1 mm dia. hole, rivet nut

Installing rivet nut

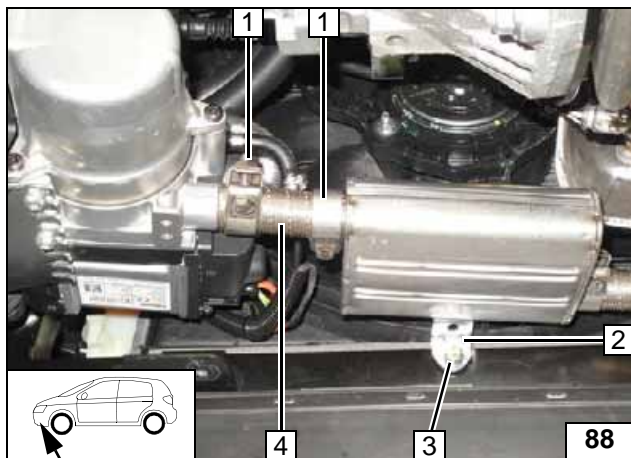

1 Hose clamp [2x]
2 Angle bracket
3 M6x20 bolt, spring lockwasher
4 Exhaust pipe

Installing silencer and exhaust pipe

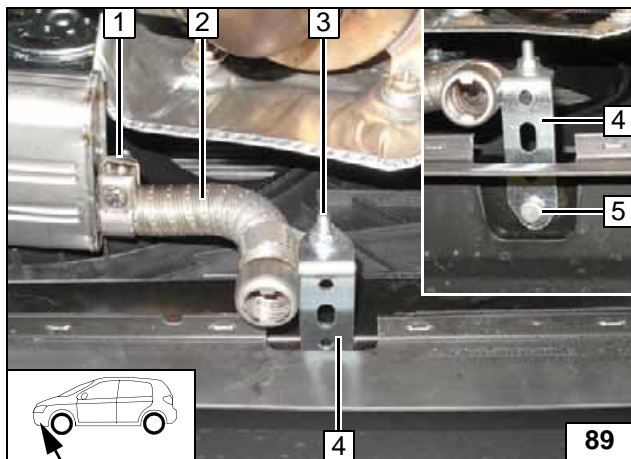

1 Hose clamp
2 Exhaust end section
3 M6x20 bolt, pipe clamp, flanged nut
4 Perforated bracket
5 M6x20 bolt, spring lockwasher, existing threaded hole

Installing exhaust pipe

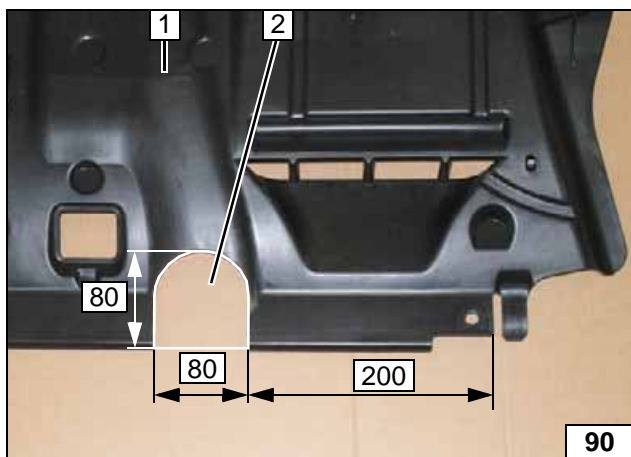

Cut out marked area of underide protection 1 (if present).

2 Discard section



Cutting out underide protection



Final Work

WARNING!

Mount removed parts in reverse order. Check all hoses, clamps and all electrical connections for firm seating. Insulate all loose wires ends and tie back.

Only use manufacturer-approved coolant. Spray the heater components with anti-corrosion wax (Tectyl 100K, Order No. 111329).



- **Connect the battery.**
- **Fill and bleed the coolant circuit according to the vehicle manufacturer's specifications.**
- **Program MultiControl CAR, teach telestart transmitter.**
- **Make settings on A/C control panel according to the "Operating Instructions for the End Customer".**
- **Place the "Switch off parking heater before refuelling" caution label in the area of the filler neck.**
- **For initial startup and function check, please see installation instructions**

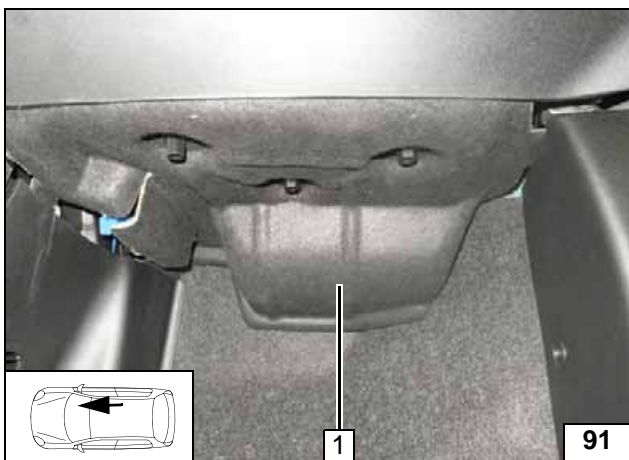

Ensure freedom of movement with respect to relay and fuse holder and Telestart receiver, correct if necessary.

1 Footwell trim of front passenger's side

Installing footwell trim

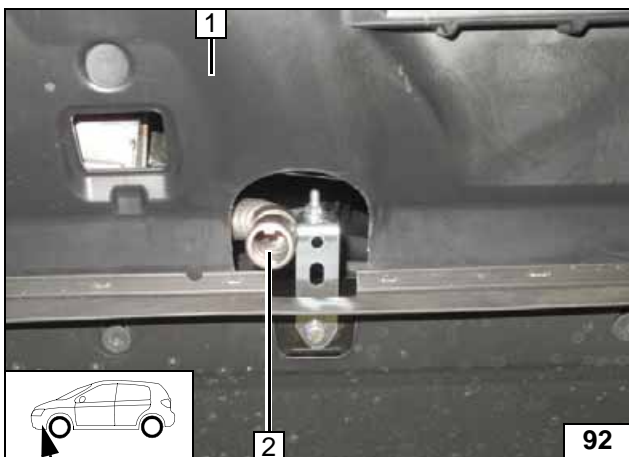

Align exhaust end section 2 in recess flush with underdrive protection 1 (if present). Ensure sufficient distance from neighbouring components, correct if necessary.



Aligning exhaust end section

Webasto Thermo & Comfort SE
 Postfach 1410
 82199 Gilching
 Germany
 Internet: www.webasto.com
 Technical Extranet:
<http://dealers.webasto.com>

Operating Instructions for Manual Air-Conditioning

Please remove page and add to the vehicle operating instructions.

Note:

We recommend matching the heating time to the driving time.
Heating time = driving time

Example:

For a driving time of approx. 20 min. (in one direction), we recommend not exceeding a switch-on time of 20 min.

Passenger compartment monitoring, if installed, must be deactivated in addition to the vehicle settings for the heating operation.

For instructions on deactivation, please refer to the operating instructions of the vehicle.

Before parking the vehicle, make the following settings:



- 1 Set fan to level "1", or max. "2"
- 2 Air outlet onto windscreen
- 3 Set temperature to "max."



A/C control panel

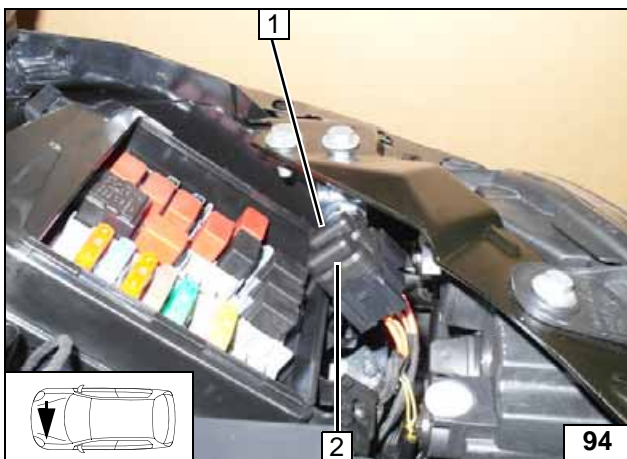

- 1 30A main fuse F2 of passenger compartment
- 2 20A heater fuse F1

Engine compartment fuses

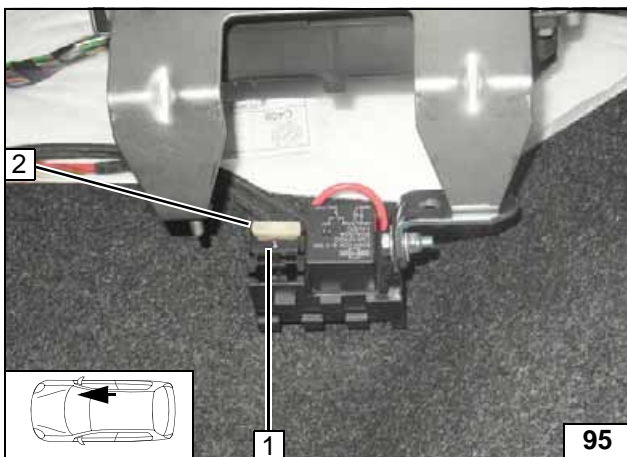

Passenger compartment fuses behind footwell trim on front passenger's side.

- 1 1A fuse F3 of heater control
- 2 25A fan fuse F4



Passenger compartment fuses

Operating Instructions for Automatic Air-Conditioning

Please remove page and add to the vehicle operating instructions.

Note:

We recommend matching the heating time to the driving time.
Heating time = driving time

Example:

For a driving time of approx. 20 min. (in one direction), we recommend not exceeding a switch-on time of 20 min.

Passenger compartment monitoring, if installed, must be deactivated in addition to the vehicle settings for the heating operation.

For instructions on deactivation, please refer to the operating instructions of the vehicle.

Before parking the vehicle, make the following settings:



- 1 Set temperature to "HI"
- 2 Air outlet faces "upward"



A/C control panel

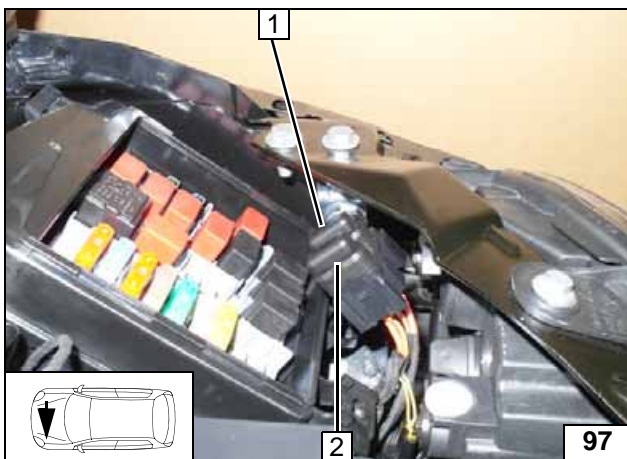

- 1 30A main fuse F2 of passenger compartment
- 2 20A heater fuse F1

Engine compartment fuses

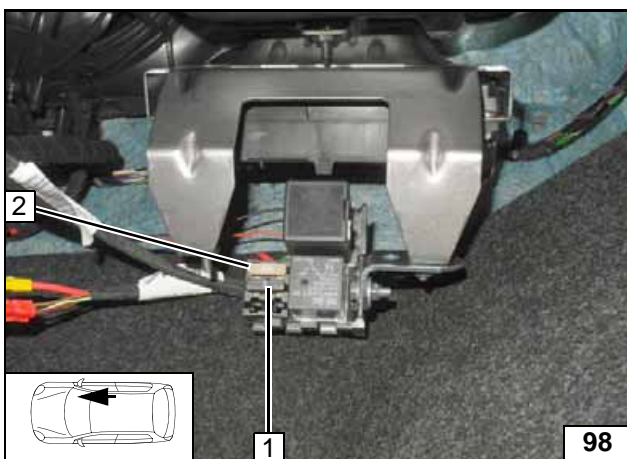

Passenger compartment fuses behind footwell trim on front passenger's side.

- 1 1A fuse F3 of heater control
- 2 25A fan fuse F4



Passenger compartment fuses

