

Water Heater

Thermo Top Evo 4 Parking Heater



Installation Documentation

Mercedes Benz W 204

Validity

Manufacturer	Model	Type	EG-BE No. / ABE
Daimler AG	C Class	W204	e1 * 2001 / 116 * 0431 * ...

Motorisation	Fuel	Transmission type	Output in kW	Displacement in cm ³	Engine code
C 180	Petrol	AG	115	1595	274.910

AG = 7-speed Tronic

From Model Year 2014

Left-hand drive vehicle

Verified equipment variants: Automatic air-conditioning
 Front fog light
 Residual heat pump
 Daytime running light
 Headlight washer system

Not verified: AMG 950 Sports Package
 AMG Optical package

Total installation time: about 12.5 hours

Mercedes Benz W 204

Table of Contents

Validity	1	Fan Controller	8
Necessary Components	2	Telestart	11
Installation Overview	2	Push Button Option	11
Notes on Total Installation Time	2	Preparing Heater	13
Information on Operating and Installation Instructions	3	Preparing Installation Location	15
Information on Validity	4	Mounting Heater	17
Technical Information	4	Exhaust Gas	18
Explanatory Notes on Document	4	Fuel	20
Preliminary Work	5	Coolant Circuit	25
Heater Installation Location	5	Combustion Air	30
Preparing Electrical System	6	Exhaust End Section	32
Electrical System	7	Final Work	33

Necessary Components

- Basic delivery scope of *Thermo Top Evo 4* based on price list
- Installation kit for Mercedes Benz W 204 2014 Petrol: **1322553**
- Heater control in accordance with price list and upon consultation with end customer
- In case of Telestart, indicator lamp in accordance with price list and in consultation with end customer
- For the optional installation of a digital timer or push button the extension for digital timer with Ident. No.: **1319724A** should also be used.

Installation instructions:

- When installing a parking heater only the *Thermo Top Evo 4* should be built in. The heater will be integrated into the "island" coolant circuit and is used to heat up the passenger compartment. The engine is not pre-heated.
- Arrange for the vehicle to be delivered with the tank only about ¼ full!
- The installation location of the push button in the case of Telestart or Thermo Call should be confirmed with the end customer.
- Depending on the available space and manufacturer's instructions, we recommend the use of a vehicle battery with more electrical capacity.

Installation Overview

Legend:

1. Heater
2. Fuse holder of engine compartment
3. PWM Gateway
4. Relay [2x]
5. Push button option
6. Circulating pump
7. Metering pump

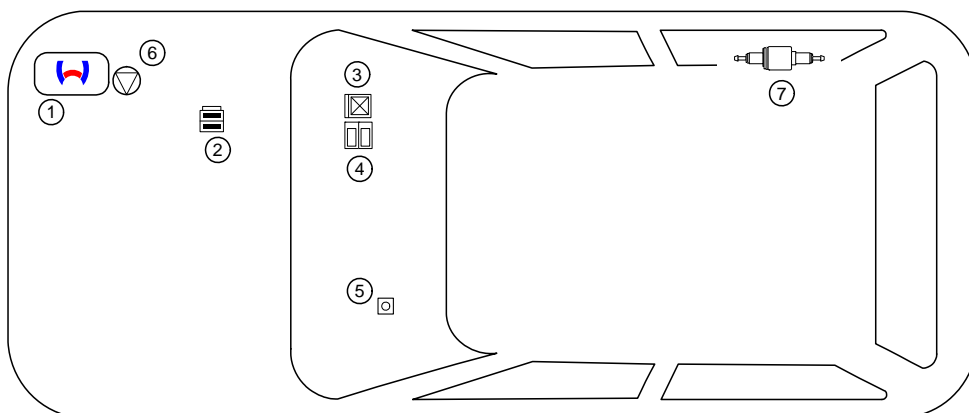

Notes on Total Installation Time

The total installation time includes the time needed for mounting and demounting of the vehicle-specific components, the heater specific installation time and all other times required for the system integration and initial start-up of the heater.

The total installation time may vary for vehicle equipment other than provided.

Information on Operating and Installation Instructions

1 Important Information (not complete)

1.1 Installation and Repair



The improper installation or repair of Webasto heating and cooling systems can cause fire or the leakage of deadly carbon monoxide, leading to serious injury or death.



To install and repair Webasto heating and cooling systems you need to have completed a special company training course and have the appropriate technical documentation, special tools and special equipment.



Installation and repair may ONLY be carried out by persons trained and certified in a Webasto training course. NEVER try to install or repair Webasto heating or cooling systems if you have not completed a Webasto training course, you do not have the necessary technical skills and you do not have the technical documentation, tools and equipment available to ensure that you can complete the installation and repair work properly.

Only use genuine Webasto parts. See the Webasto air and water heaters accessories catalogue for this purpose.

1.2 Operation

To ensure safe operation, we recommend having the heater checked every two years by an authorised Webasto dealer, especially when used over a long period and/or under extreme environmental conditions.

Do not operate the heater in closed rooms due to the danger of poisoning and suffocation.

Always switch off the heater before refuelling.

The heater may only be used with the prescribed fuel Diesel (DIN EN 590) or petrol (DIN EN 228).

The heater may not be cleaned with a high-pressure cleaner.

1.3 Please note

ALWAYS follow all Webasto installation and operating instructions and observe all warnings.

To become familiar with and understand all functions and properties of the heater, the operating instructions must be read carefully and observed at all times.

For proper, safe installation and repair work, the installation instructions with all warnings and safety information must be carefully read and observed at all times. Please always contact a workshop authorised by Webasto for all installation and repair work.

Important

Webasto shall assume no liability for defects, damage and injuries resulting from a failure to observe the installation, repair and operating instructions of the information contained in them.

This liability exclusion particularly applies to improper installations and repairs, installations and repairs by untrained persons or in the case of a failure to use genuine spare parts.

The liability due to culpable disregard to life, limb or health and due to damage or injuries caused by a wilful or reckless breach of duty remain unaffected, as does the obligatory product liability.

Installation should be carried out according to the general, standard rules of technology. Unless specified otherwise, fasten hoses, lines and wiring harnesses to original vehicle lines and wiring harnesses using cable ties. Insulate loose wire ends and tie back. Connectors on electronic components must audibly snap into place during assembly.

Sharp edges should be fitted with rub protection. Spray unfinished body areas, e.g. drilled holes, with anti-corrosion wax (Tectyl 100K, Order No. 111329).

Observe the instructions and guidelines of the respective vehicle manufacturer for demounting and mounting vehicle specific components!

The initial startup is to be executed with the Webasto Thermo Test Diagnosis.

When installing a programmable control module (e.g. a PWM Gateway), the corresponding settings must be checked or adjusted.

2 Statutory regulations governing installation

Guidelines	Thermo Top Evo
Heating Directive ECE R122	E1 00 0258
EMC Directive ECE R10	E1 04 5627

Note

The regulations of these guidelines are binding in the scope of the Directive 70/156/EEC and/or 2007/46/EC (for new vehicle models from 29/04/2009) and should also be observed in countries in which there are no special regulations.

Important

Failure to follow the installation instructions will result in the invalidation of the type approval for the heater and therefore invalidation of the general **homologation of the vehicle**.

Note

The heater is licensed in accordance with paragraph 19, section 3, No. 2b of the StVZO (German Road Traffic Licensing Authority).

2.1 Excerpt from ECE regulation 122 (heating system) paragraph 5 for the installation of the heater

Beginning of excerpt.

ANNEX VII

REQUIREMENTS FOR COMBUSTION HEATERS AND THEIR INSTALLATION

1. GENERAL REQUIREMENTS

1.7.1. A clearly visible tell-tale in the operator's field of view shall inform when the combustion heater is switched on or off.

2. VEHICLE INSTALLATION REQUIREMENTS

2.1. Scope

2.1.1. Subject to paragraph 2.1.2. combustion heaters shall be installed according to the requirements of this Annex.

2.1.2. Vehicles of category O having liquid fuel heaters are deemed to comply with the requirements of this Annex.

2.2. Positioning of heater

2.2.1. Body sections and any other components in the vicinity of the heater must be protected from excessive heat and the possibility of fuel or oil contamination.

2.2.2. The combustion heater shall not constitute a risk of fire, even in the case of overheating. This requirement shall be deemed to be fulfilled if the installation ensures an adequate distance to all parts and suitable ventilation, by the use of fire resistant materials or by the use of heat shields.

2.2.3. In the case of M2 and M3 vehicles, the heater must not be positioned in the passenger compartment. However, an installation in an effectively sealed envelope which also complies with the conditions in paragraph 2.2.2 may be used.

2.2.4. The label referred to in paragraph 1.4 or a duplicate, must be positioned so that it can be easily read when the heater is installed in the vehicle.

2.2.5. Every reasonable precaution should be taken in positioning the heater to minimise the risk of injury and damage to personal property.

2.3. Fuel supply

2.3.1. The fuel filler must not be situated in the passenger compartment and must be provided with an effective cap to prevent fuel spillage.

2.3.2. In the case of liquid fuel heaters, where a supply separate to that of the vehicle is provided, the type of fuel and its filler point must be clearly labelled.

2.3.3. A notice, indicating that the heater must be shut down before refuelling, must be affixed to the fuelling point. In addition a suitable instruction must be included in the manufacturer's operating manual.

2.4. Exhaust system

2.4.1. The exhaust outlet must be located so as to prevent emissions from entering the vehicle through ventilators, heated air inlets or opening windows.

2.5. Combustion air inlet

2.5.1. The air for the combustion chamber of the heater must not be drawn from the passenger compartment of the vehicle.

2.5.2. The air inlet must be so positioned or guarded that blocking by rubbish or luggage is unlikely.

2.6. Heating air inlet

2.6.1. The heating air supply may be fresh or recirculated air and must be drawn from a clean area not likely to be contaminated by exhaust fumes emitted either by the propulsion engine, the combustion heater or any other vehicle source.

2.6.2. The inlet duct must be protected by mesh or other suitable means.

2.7. Heating air outlet

2.7.1. Any ducting used to route the hot air through the vehicle must be so positioned or protected that no injury or damage could be caused if it were to be touched.

2.7.2. The air outlet must be so positioned or guarded that blocking by rubbish or luggage is unlikely.

End of excerpt.

In multilingual versions the German language is binding.

Mercedes Benz W 204

Information on Validity

This installation documentation applies to Mercedes Benz W 204 Petrol vehicles - for validity, see page 1 - from model year 2014 and later, assuming technical modifications to the vehicle do not affect installation, any liability claims excluded. Depending on the vehicle version and equipment, modifications may be necessary during installation with respect to this installation documentation.

Vehicle and engine types, equipment variants and other specifications not listed in this installation documentation have not been tested. However, installation according to this installation documentation may be possible.

Technical Information

Special Tools

- Hose clamp pliers for self-clamping hose clamps
- Hose clamp pliers for Clic hose clamps of type W
- Automatic wire stripper 0.2 - 6mm²
- Crimping pliers for cable lug / tab connector 0.5 - 6mm²
- Torque wrench for 1.0 - 10 Nm
- Hose clamping pliers
- Metric thread-setter kit
- Webasto Thermo Test diagnosis with current software

Dimensions

- All dimensions are in mm.

Tightening torque values

- Tightening torque values for 5x13 heater bolts and 5x11 heater stud bolts = 8Nm.
- Tightening torque values of 5x15 retaining plate of water connection piece bolt = 7Nm.
- Tighten other bolt connections in accordance with manufacturer's instructions or in accordance with state-of-the-art-technology.

Explanatory Notes on Document

You will find an identification mark on the outside top right corner of the page in question to provide you with a quick overview of the individual working steps.

Special features are highlighted using the following symbols:

Mechanical system



Specific risk of injury or fatal accidents



Electrical system



Specific risk due to electrical voltage



Coolant circuit

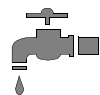

Specific risk of damage to components



Combustion air

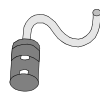

Specific risk of fire or explosion



Fuel



Reference to general installation instructions of the Webasto components or to the manufacturer's vehicle-specific documents



Reference to a special technical feature



Exhaust gas



The arrow in the vehicle icon indicates the position on the vehicle and the viewing angle

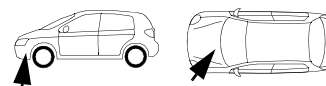

Software



Tightening torque according to the manufacturer's vehicle-specific documents



Mercedes Benz W 204

Preliminary Work

Vehicle

- Open the fuel tank cap.
- Ventilate the tank.
- Close the fuel tank cap again.
- Depressurise the cooling system.
- Drain off the coolant.
- Disconnect the battery.
- Remove the trim of the passenger compartment fan air intake.
- Remove the windscreen wipers.
- Remove the coolant reservoir cap.
- Remove the strut brace on the left.
- Remove the windscreen wiper motor fully.
- Remove the cover of the air intake for the passenger compartment fan in the engine compartment on the right.
- Remove the trim of the passenger compartment fan air inlet.
- Remove the battery with the carrier fully.
- Remove the battery control unit.
- Remove the engine design cover.
- Remove the lower engine cover.
- Remove the lower vehicle trim (right).
- Remove the right-hand front wheel.
- Remove the wheel well trim (right).
- Remove the seat of the rear bench seat.
- Remove the fuel-tank sending unit in accordance with the manufacturer's instructions (right).
- Cover below the instrument panel on the driver's side.
- Remove the door sill panel trim at the front right.
- Remove the lower A-pillar trim at the front right.
- Fold back the front cover in the footwell on the front passenger's side, loosen the cover plate (plastic nuts) and tilt back.
- Remove the front A/C control panel.
- Remove the cover of the shift lever or storage compartment.
- Remove the ashtray or storage compartment with the socket outlet below the A/C control panel.
- Drain off the engine coolant according to the manufacturer's instructions.

Heater

- Remove years that do not apply from the type and duplicate label.
- Attach the duplicate label (type label) in the appropriate place inside the engine compartment.

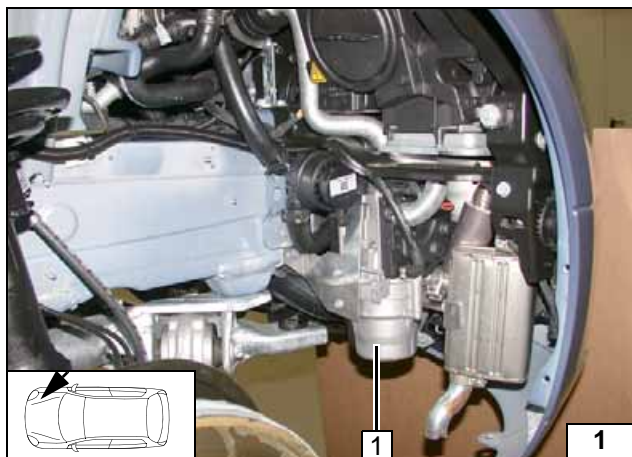

Heater Installation Location

- 1 Heater

Installation location

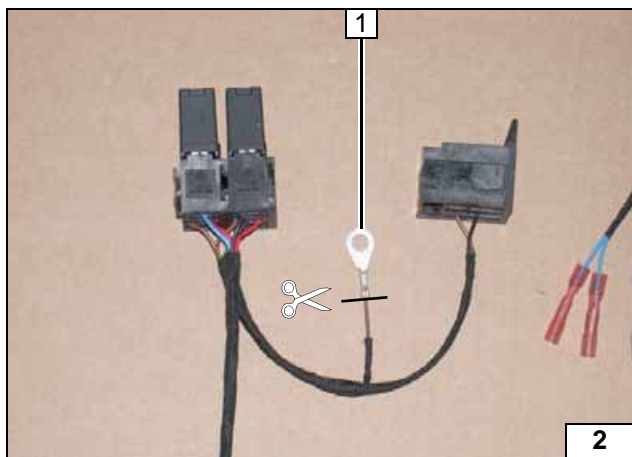

Preparing Electrical System

Wire sections retain their numbering in the entire document.

Produce all following electrical connections as shown in wiring diagram.

Detach 6mm dia. cable lug 1.



Preparing fan controller wiring harness

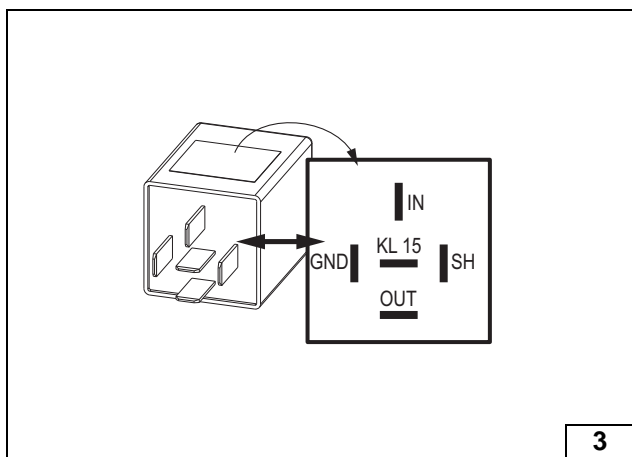

Check the PWM Gateway settings when starting up the heater and adjust if necessary.

Settings:

- Duty cycle: 70%
- Frequency: 400Hz
- Voltage: 3.0V
- Function: High-side



Preparing PWM Gateway

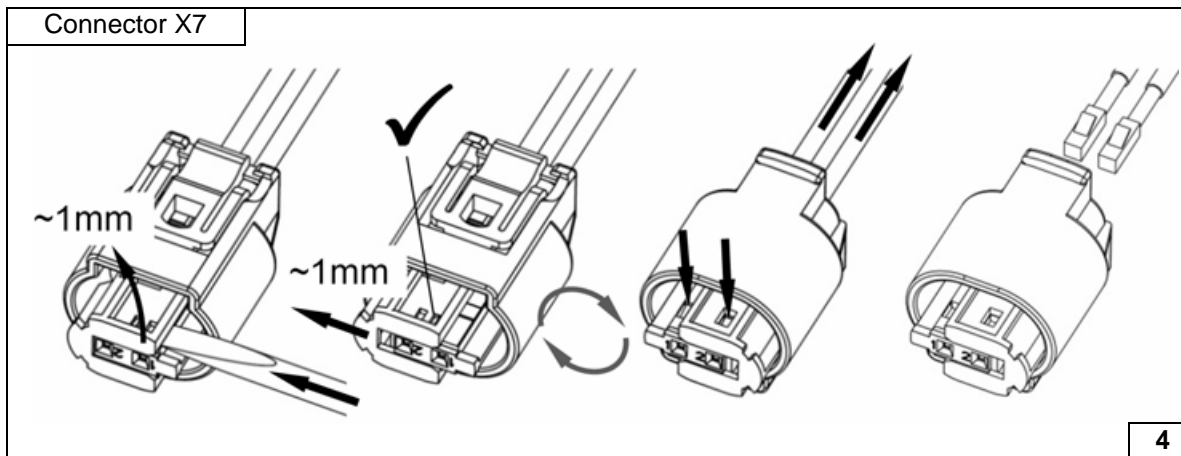

Removing metering pump connector

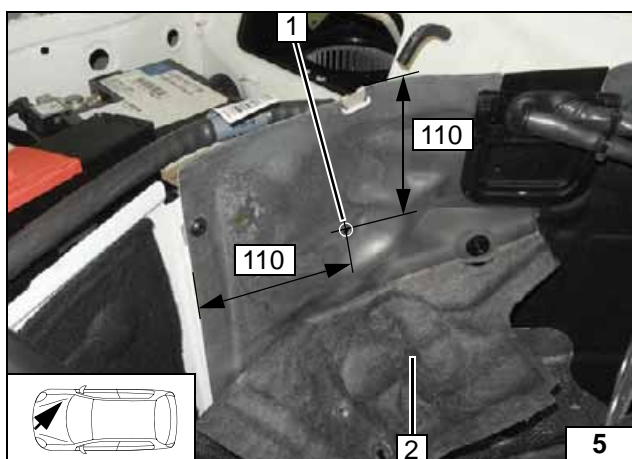

Detach insulation protection mat 2 and put it aside. 6.5mm dia. hole in middle of embossing 1. When drilling, watch components located behind.

1 6.5 mm dia. hole



Preparing installation location of engine compartment fuse holder

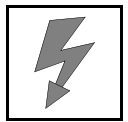

Electrical System

Earth wire

Connect earth wire 1 to the original vehicle earth support point 2 with 8 mm dia. cable lug. Route wiring harness to heater in 10mm dia. corrugated tube 3.

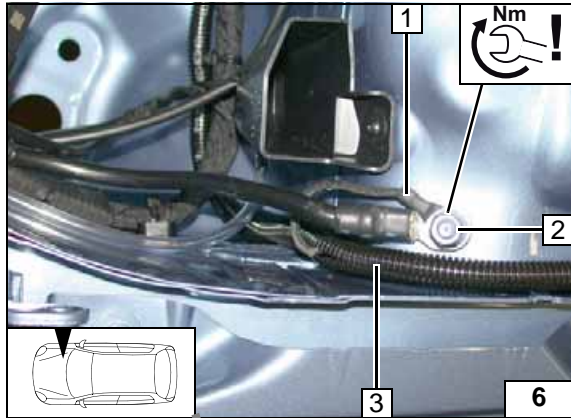

Wiring harness pass through

Drill 6 mm dia. hole 2 at centre of protective rubber plug 1, if original vehicle wiring harness is not available.

3 Wiring harnesses of heater and heater control

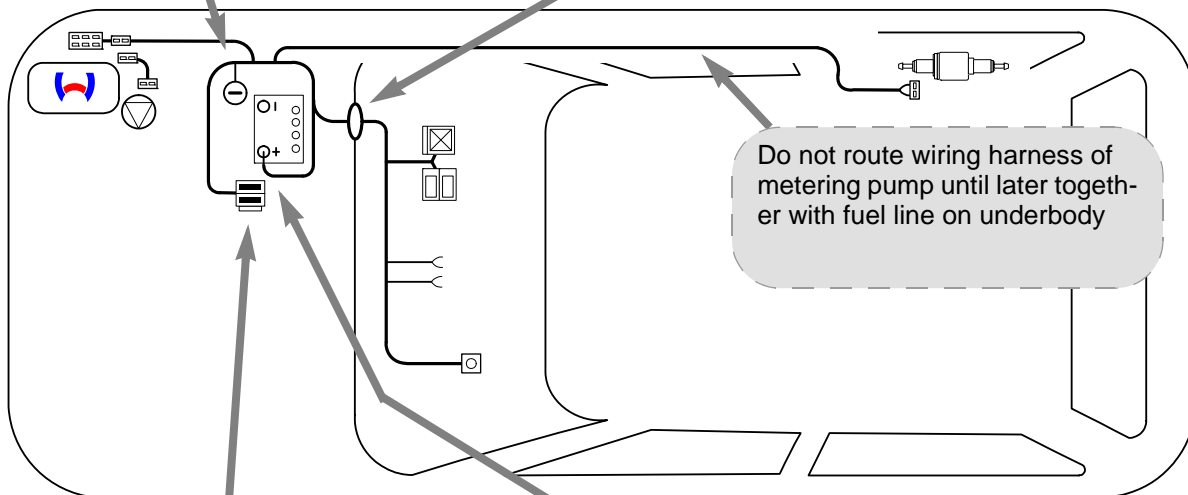
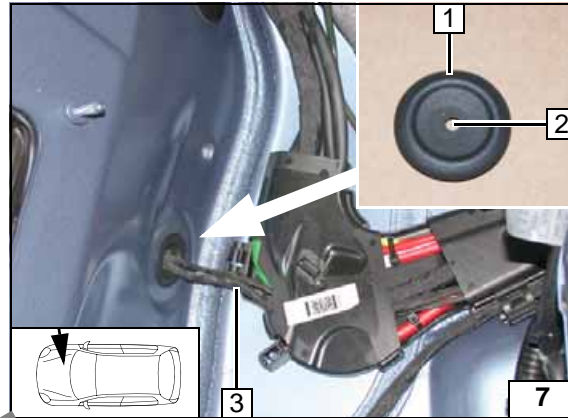

Wiring harness routing diagram

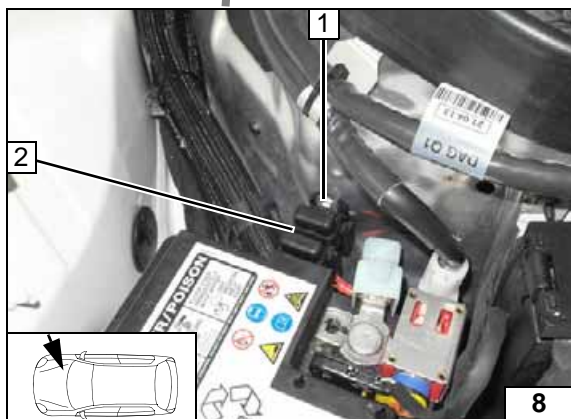

Fuse holder of engine compartment

Replace F2 with 1 A fuse.

- 1 M5x12 bolt, washer [2x], retaining plate of fuse holder, flanged nut
- 2 F1+2 fuses mounted

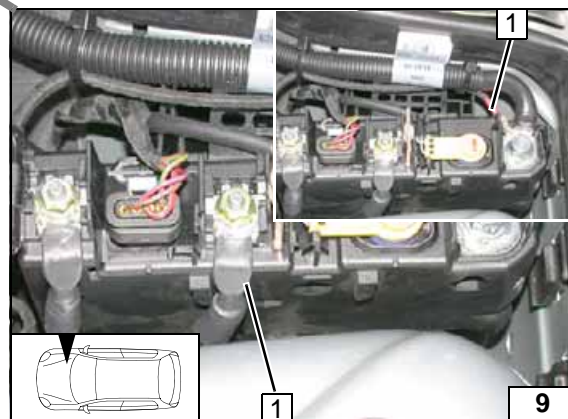

Positive wire

Manufacturer installs different positive support points. Connect power supply of heater 1 to positive terminal (battery or starter cable of positive support point).

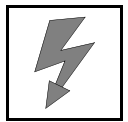

Fan Controller

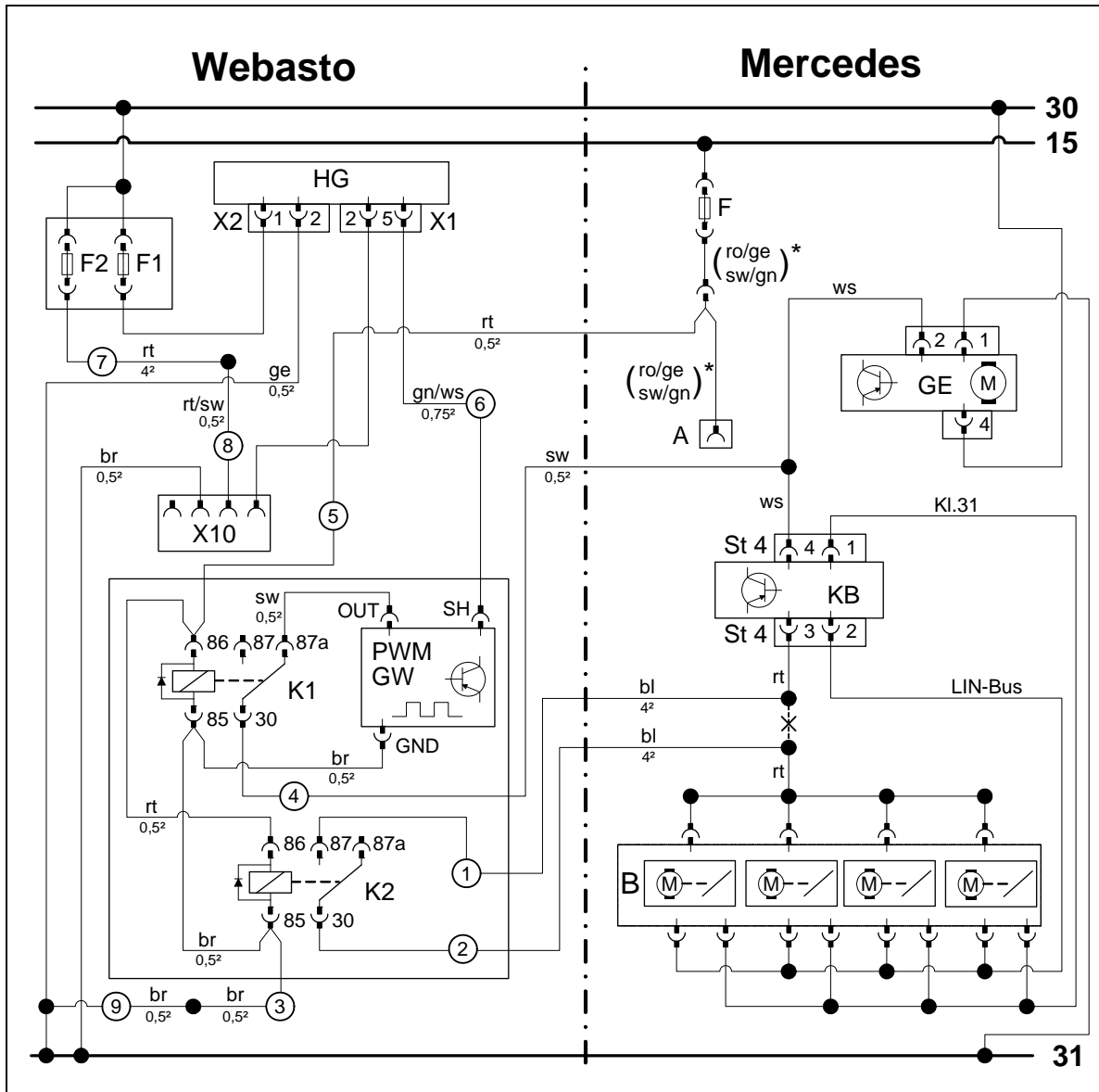

Wiring diagram

Webasto components		Vehicle components		Colours and symbols	
HG	TT-Evo heater	F	fuse	rt	red
X1	6-pin heater connector	GE	Fan unit	ws	white
X2	2-pin heater connector	A	Socket outlet/lighter	sw	black
F1	20A fuse	KB	A/C control panel	bl	blue
F2	Replace 30A with 1A fuse.	ST 4	Connector, 4-pin, KB	ge	yellow
X10	4-pin connector of heater control	B	Flap positioning module	br	brown
PWM GW	Pulse width modulator			gn	green
K1	Fan relay			rt/sw	red/black
K2	Additional relay			gn/ws	green/white
PWM GW settings:				ro/ge	pink/yellow
Duty cycle: 70%				sw/gn	black/green
Frequency: 400Hz				*	depending on the equipment
Voltage: 3.0V				X	Cutting point
Function: High-side				Wiring colours may vary.	

Legend

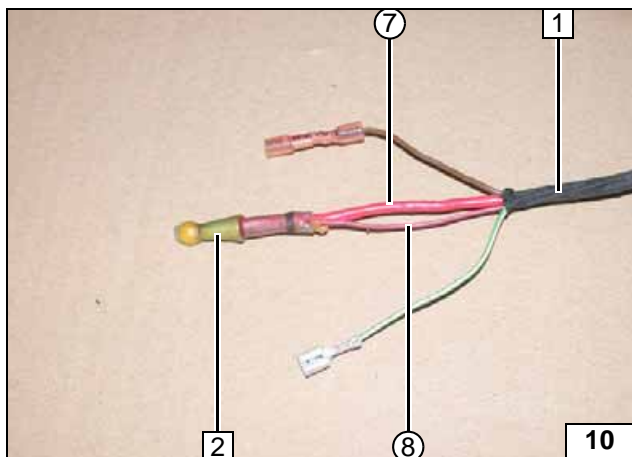

Prepare wiring harness of heater **1** in the passenger compartment. Connect red (rt) wire 4² (7) and red/black (rt/sw) wire 0,5² (8) to solder wire terminator **2**.



Preparing wiring harness of heater

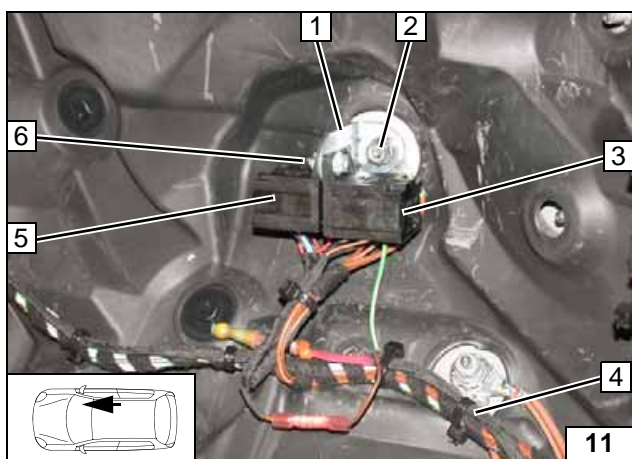

Route wiring harness of heater **4** in the footwell on the front passenger's side, and secure with cable ties.



- 1 Angle bracket
- 2 Original vehicle stud bolt, original vehicle earth wires
- 3 PWM Gateway socket
- 5 Relay socket [2x]
- 6 M5x16 bolt, washer, flanged nut

Mounting relay socket and PWM Gateway socket

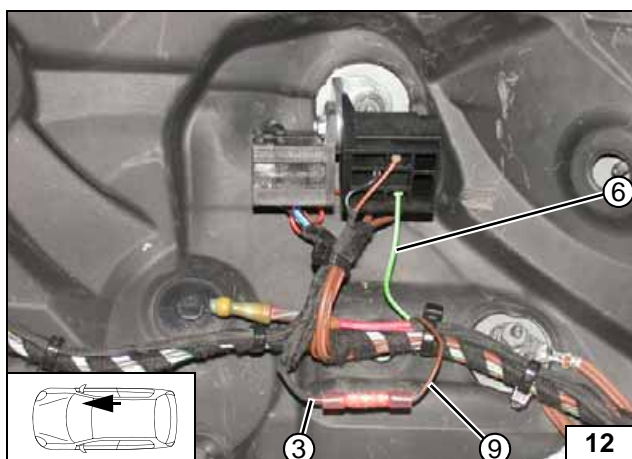

Insert green/white (gn/ws) wire (6) into PWM GW/SH socket.



- (3) Brown (br) wire of heater wiring harness
- (9) Brown (br) wire of fan controller wiring harness

Connecting wiring harnesses

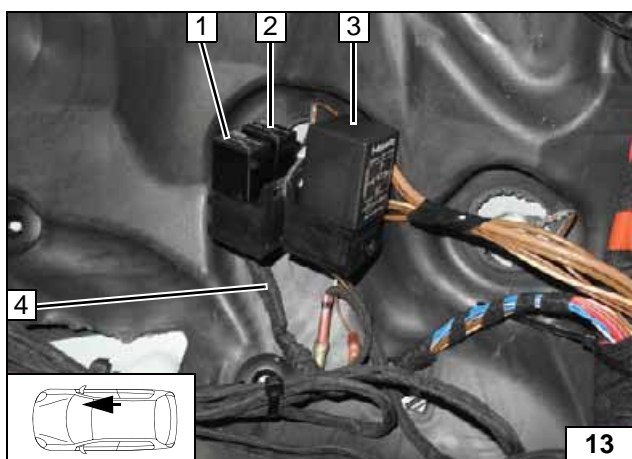

Route wiring harness of fan controller **4** to centre console and secure with cable ties.



- 1 K2 relay
- 2 K1 relay
- 3 PWM Gateway

Mounting relay [2x] and PWM GW

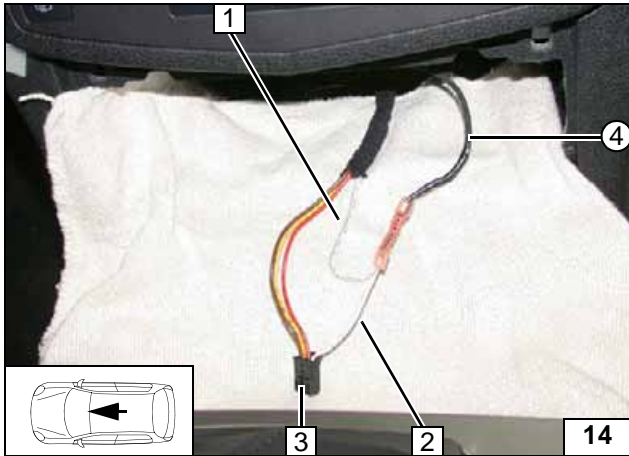

Connection to 4-pin connector **3** from A/C control panel.

- 1 White (ws) wire of fan unit
- 2 White (ws) wire of 4-pin connector KB
- ④ Black (sw) wire of K1/30



**Connect-
ing A/C
control
panel**

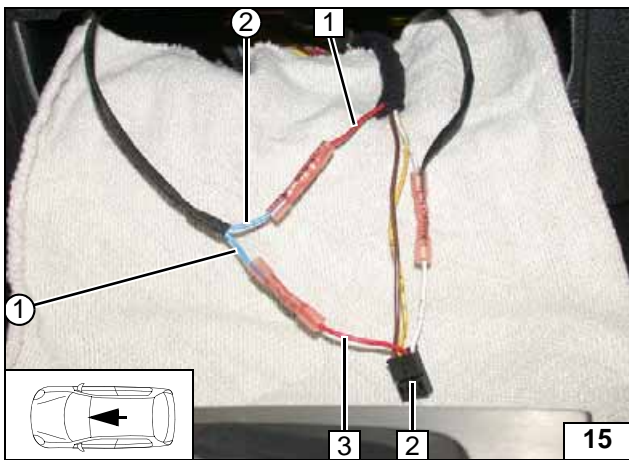

Connection to 4-pin connector **2** from A/C control panel.

- 1 Red (rt) wire of flap positioning module
- 3 Red (rt) wire of 4-pin connector KB
- ① Blue (bl) wire of K2/87
- ② Blue (bl) wire of K2/30



**Connect-
ing A/C
control
panel**

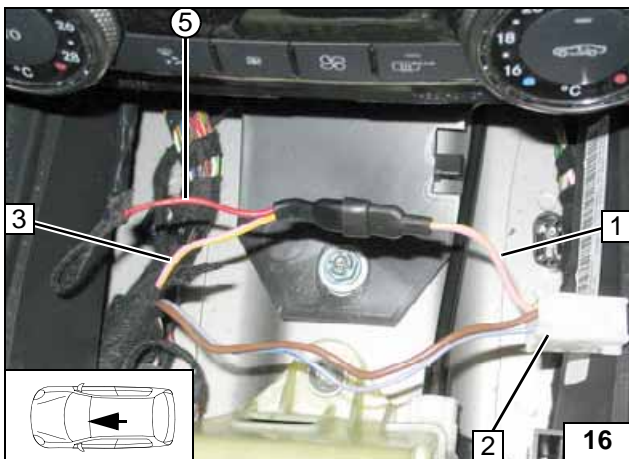

Connection to plug-in connector **2** of socket outlet/lighter.

- 1 Pink/yellow (ro/ge) wire or black/green (sw/gn) wire of socket outlet/lighter
- 3 Pink/yellow (ro/ge) wire or black/green (sw/gn) wire of fuse
- ⑤ Red (rt) wire of K1/86



**Connec-
tion to
socket out-
let/lighter**

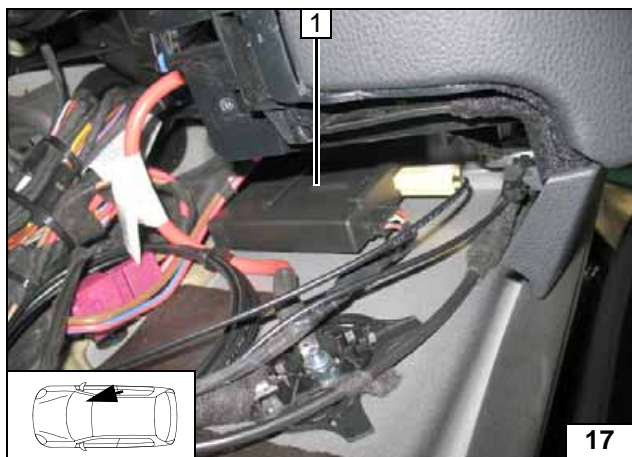

Telestart

- 1 Receiver, adhesive tape

Installing receiver

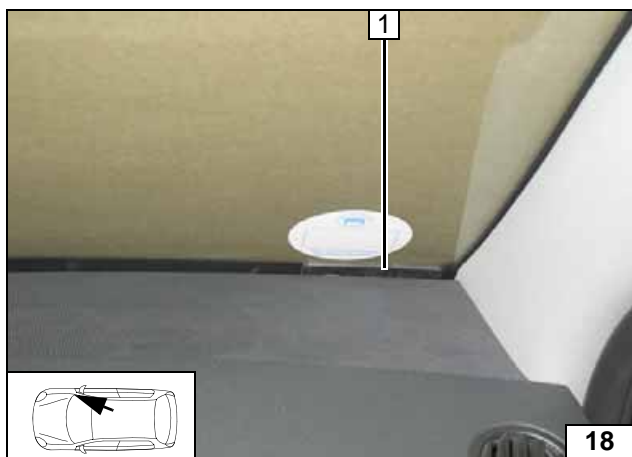

- 1 Antenna

Installing antenna



Push Button Option

Only in connection with Telestart. Use wiring harness extension.

WARNING:

If the push button cannot be installed in the trim piece due to parts lying behind it, the installation is done as shown in figure 24.

- 1 Cover



Removing cover

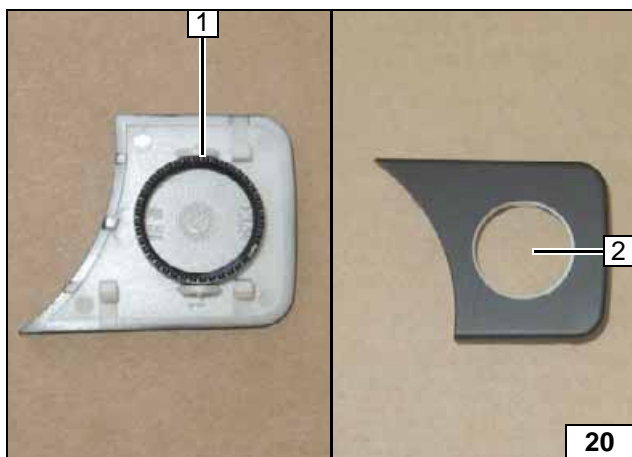

Mount union nut 1 of push button, align in centre and drill 16mm dia. hole 2 in the cover (stepped drill bit).



Hole in cover

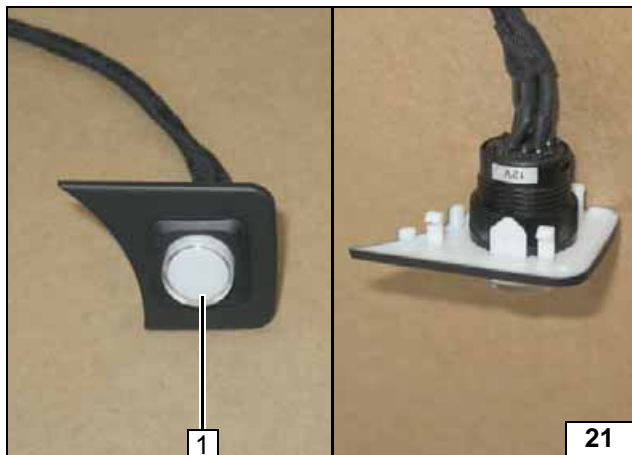

Install push button 1, align and secure it with union nut.



Mounting push button

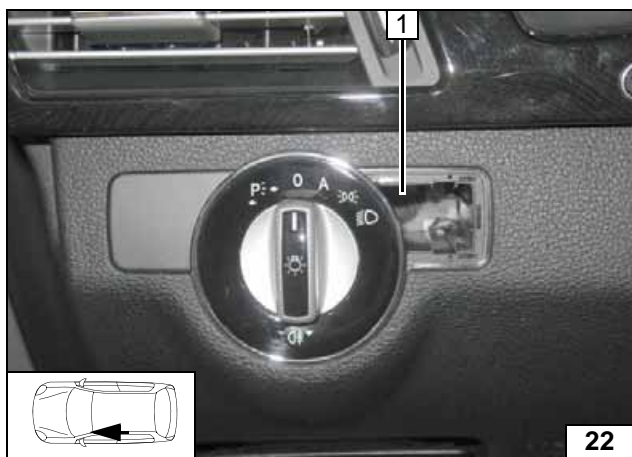

When drilling, watch components located behind.



1 12mm dia. hole

Hole for wiring harness

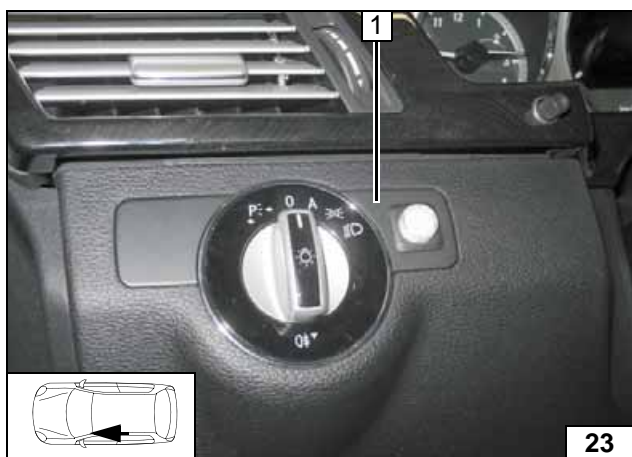

1 Cover

Mounting cover

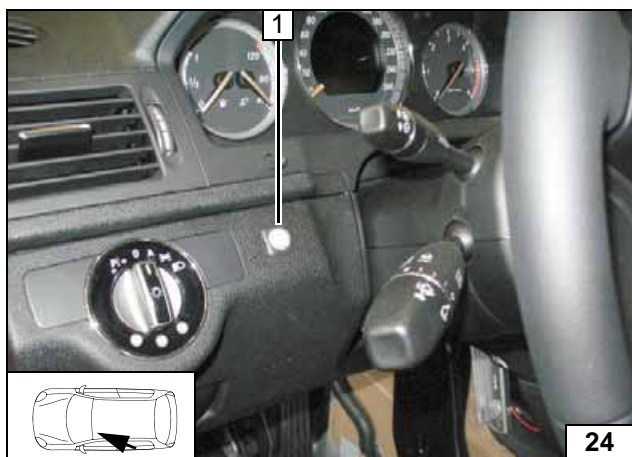

Alternative installation location

Only in connection with Telearstart. Use wiring harness extension.

1 12mm dia. hole, push button



Mounting push button

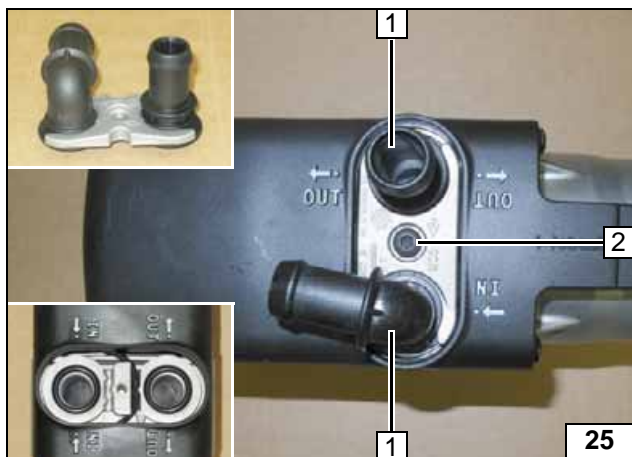
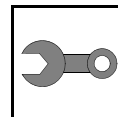

Preparing Heater

- 1 Water connection piece, sealing ring [2x each]
- 2 5x15 self-tapping bolt, retaining plate of water connection piece



Installing water connection piece

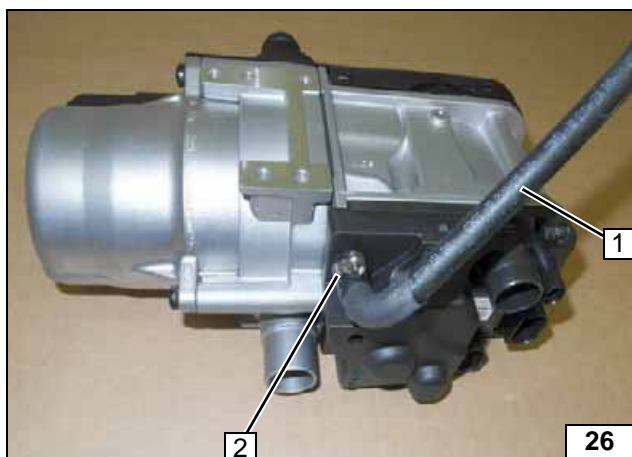

- 1 90° moulded hose
- 2 10 mm dia. clamp

Premounting moulded hose

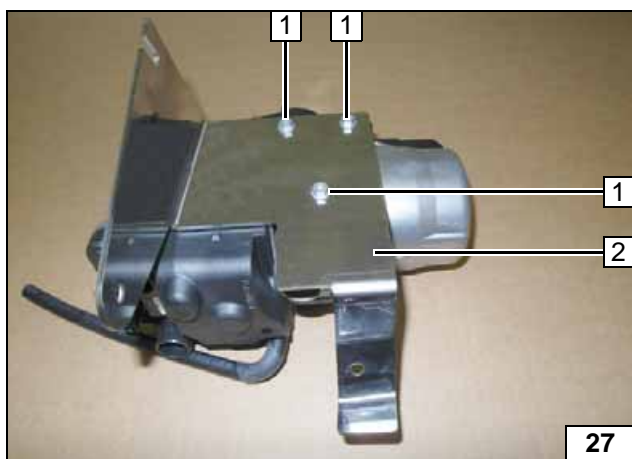

- 1 5x13 self-tapping bolt [3x]
- 2 Part 1 of bracket

Premounting section 1 of bracket

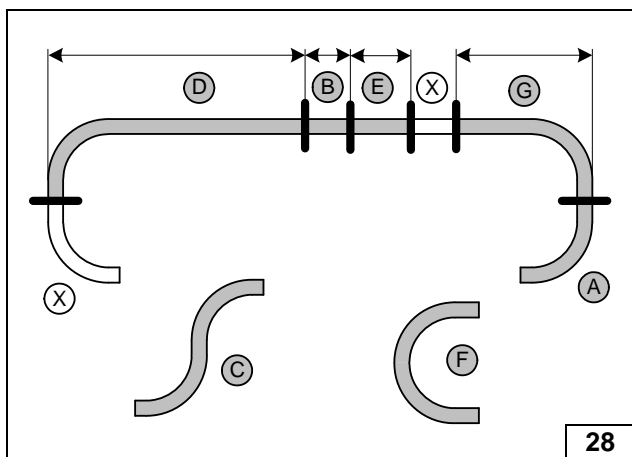

Discard section X.
 Hose A = 90° moulded hose
 Hose C = 2x90°, 18mm dia. moulded hose
 Hose F = 180°, 18mm dia. moulded hose

- B = 100
- D = 1410
- E = 400
- G = 420



Cutting hoses to length

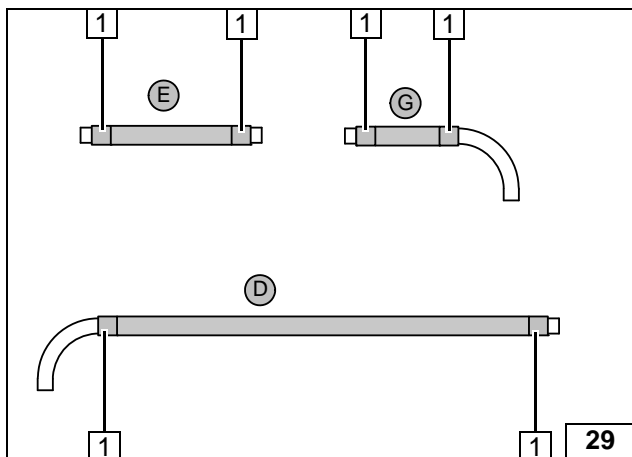
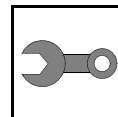

Push braided protection hoses onto hose **D**, **E** and **G** and cut to length. Cut heat shrink plastic tubing to size.

- 1 50 mm long heat shrink plastic tubing [6x]



Preparing hoses

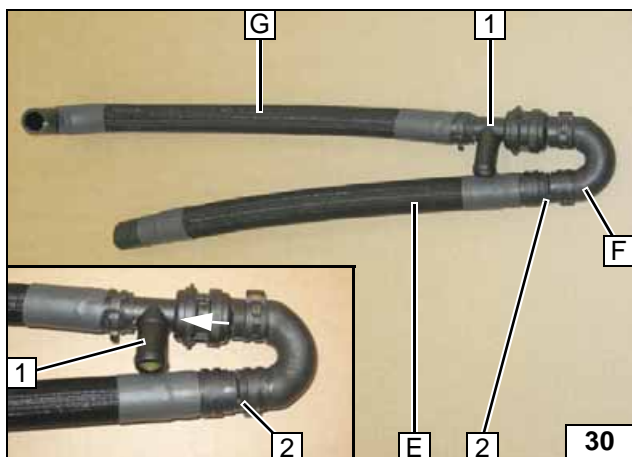

- 1 Check valve, 25 mm dia. spring clip [2x]
- 2 18x18mm dia. connecting pipe, 25mm dia. spring clip [2x]

Premounting hoses E, F and G

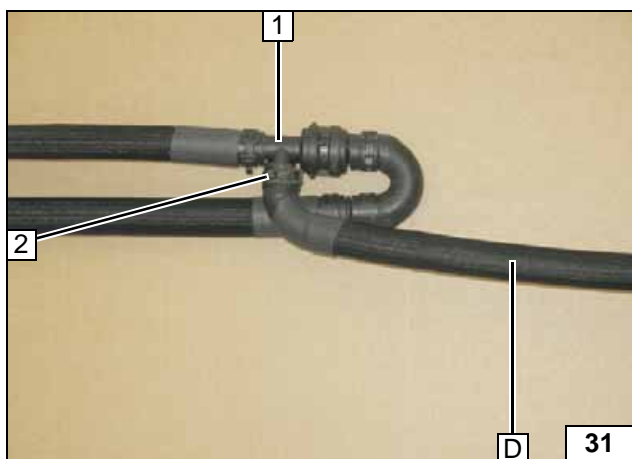

- 1 Check valve.
- 2 25 mm dia. spring clip

Premounting hose D

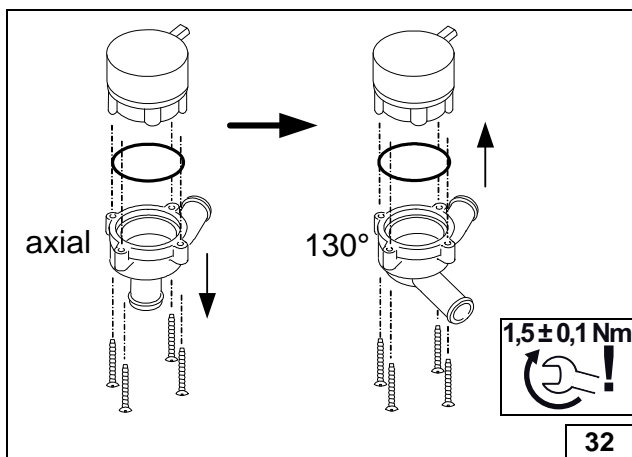

Replace axial cover of circulating pump with 130° cover. Strictly observe the torque!



Modifying circulating pump



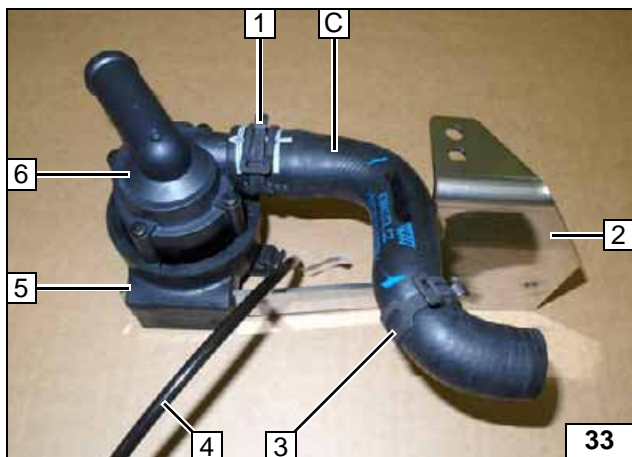
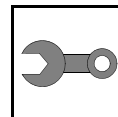

- 1 27 mm dia. spring clip
- 2 Part 2 of bracket
- 3 Slide on 25 mm dia. spring clip
- 4 Wiring harness of circulating pump
- 5 Circulating pump support
- 6 Circulating pump

Premounting circulating pump

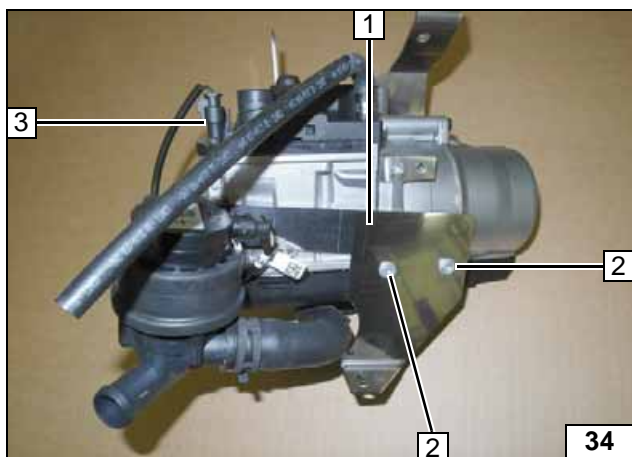

- 1 Part 2 of bracket
- 2 5x13 self-tapping bolts [2x]
- 3 Wiring harness of circulating pump

Premounting heater

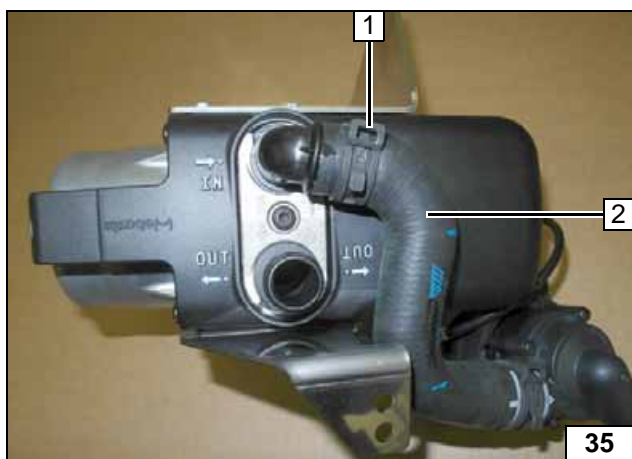

- 1 25 mm dia. spring clip

Mounting hose C

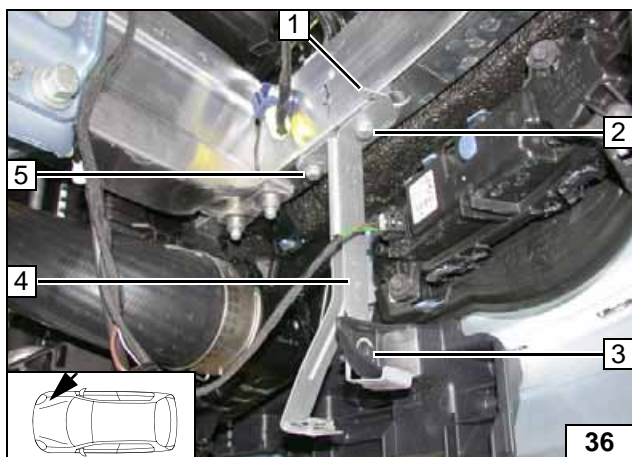

Preparing Installation Location

Figure shows vehicle with daytime running lights.

Loosen original vehicle bolt at positions 2, 3 and 5. Insert large diameter washer at position 5 between bracket 4 and bumper. Tighten bolts at position 3 and 5

Bend back twist protection at position 1. If necessary, twist cylinder of headlight washer system and secure with cable tie (ensure sufficient spacing between connector of front fog light, if available, and bracket of heater).

Detaching bracket

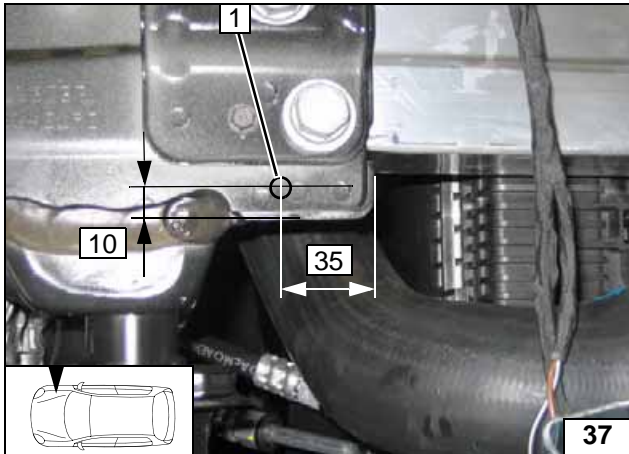
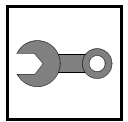

Remove joint sealer on inside of frame side member, in the area of hole 1.

- 1 7 mm dia. hole



Hole in frame side member

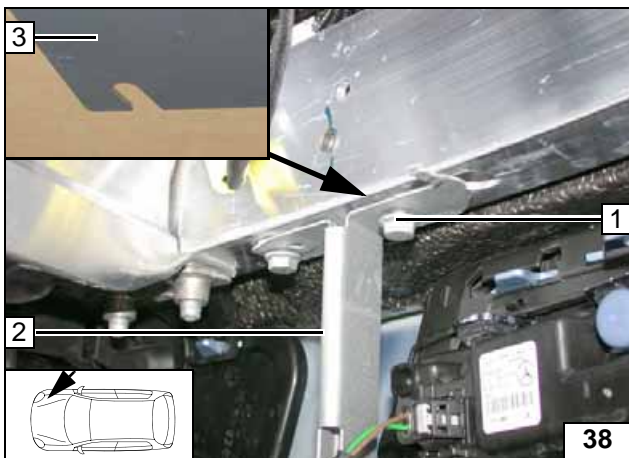
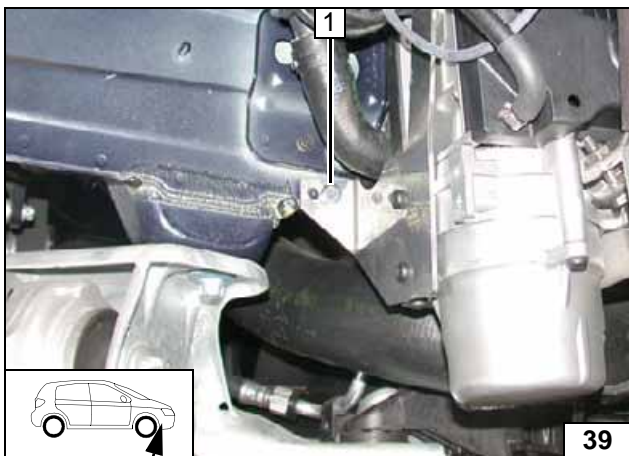

Figure shows vehicle with daytime running lights. Mount heater bracket 3 with oblong hole between detached bracket 2 and bumper at position 1.

- 1 Original vehicle bolt



Installing heater



- 1 M6x20 bolt, flanged nut

Loosely mounting heater

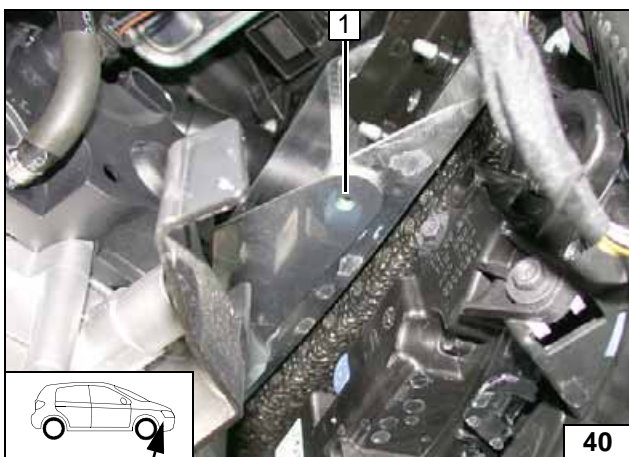

Vehicle with daytime running lights

- 1 Copy 7 mm dia. hole pattern

Copying hole pattern

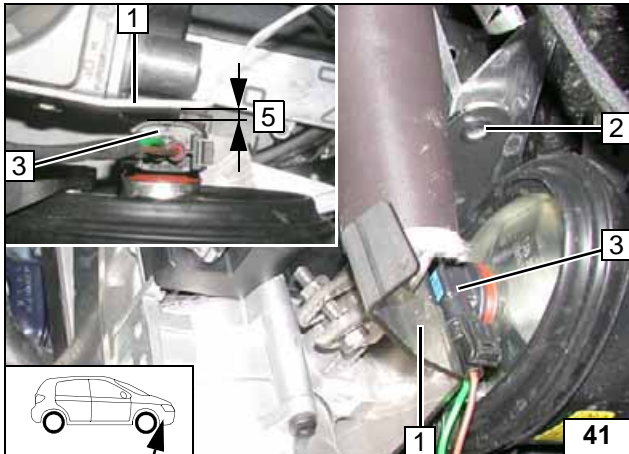

Vehicle with front fog light

Ensure proper spacing between connector of front fog light **3** and bracket of heater **1** (at least 5mm).

- 2** Copy 7 mm dia. hole pattern



Copying hole pattern

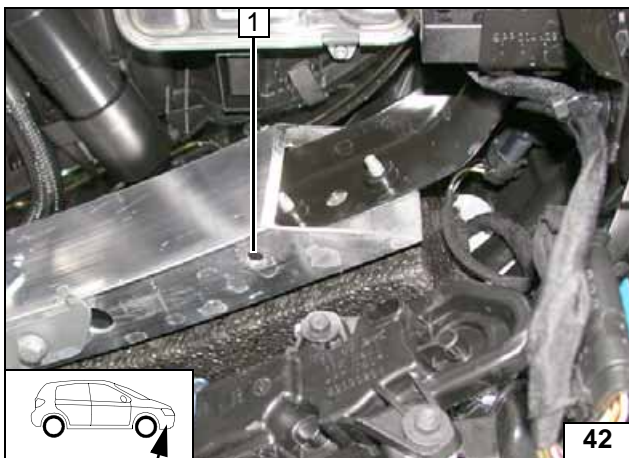

Figure shows vehicle with daytime running lights.

Remove heater. If vehicles have front fog lights, these must be removed in order to make the hole.

- 1** 7 mm dia. hole



Hole in bumper

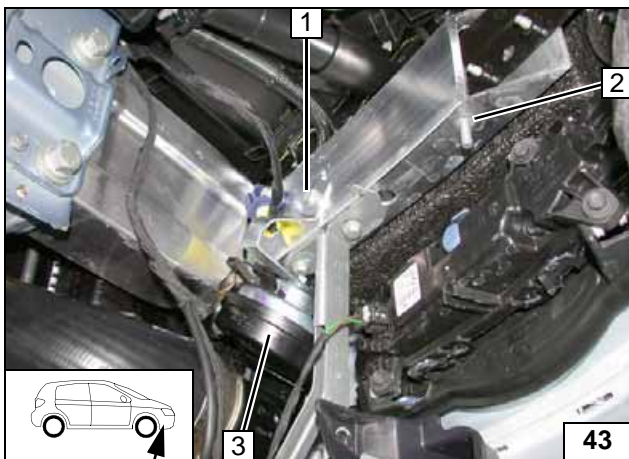

Figure shows vehicle with daytime running lights.

Install horn **3** with original vehicle bolt **1**.

- 2** M6x20 bolt, pin lock



Mounting bolt

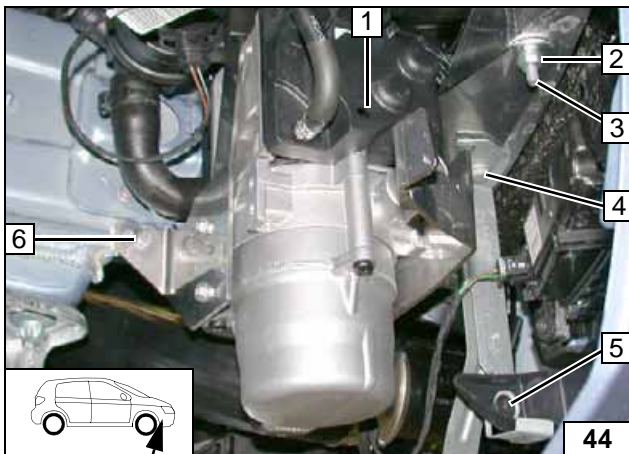

Mounting Heater

Figure shows vehicle with daytime running lights.

Mount bracket of heater **1** on bolt **3** between detached bracket and bumper. Align heater and fasten at position **4** and **6**.

Tighten original vehicle bolt at position **5**. Tighten bolt **4** on retaining strut.

- 2** Flanged nut
- 6** M6x20 bolt, flanged nut



Installing heater

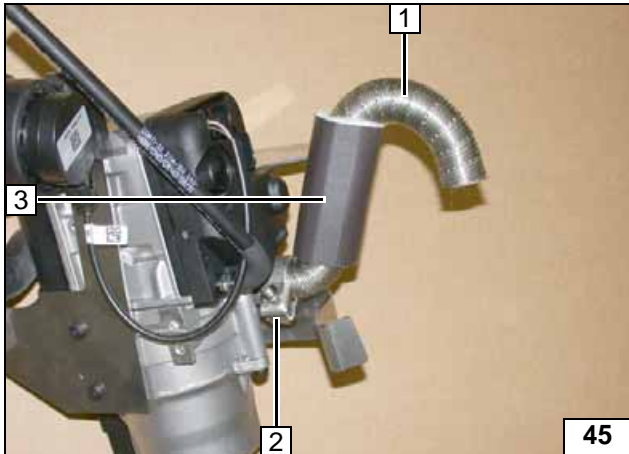

Exhaust Gas

- 1 Shape exhaust pipe
- 2 Hose clamp
- 3 Push on pipe insulation

Premounting exhaust pipe

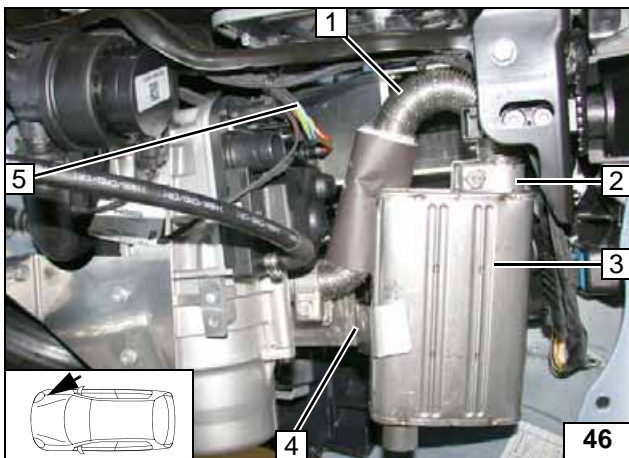

Mount exhaust silencer 3 on exhaust pipe 1 and align relative to hole 4. Mount wiring harness 5 on heater.

- 2 Hose clamp

Premounting silencer

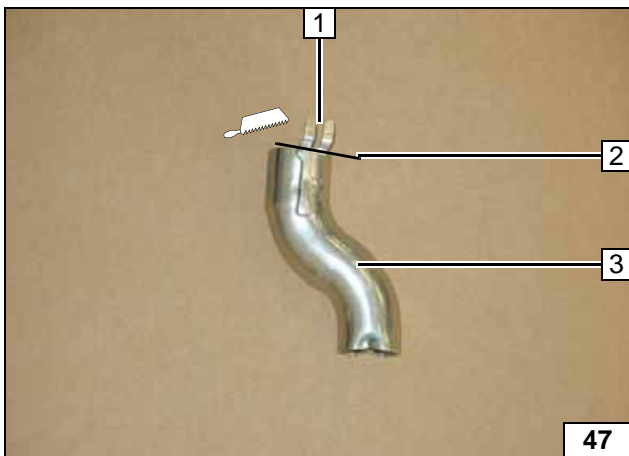

Cut tab 1 off exhaust end section 3.

- 2 Cutting point

Preparing exhaust end section

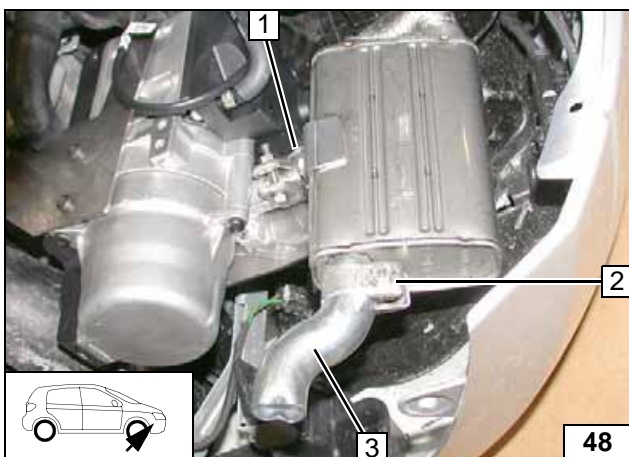

Vehicle with daytime running lights

- 1 M6x12 bolt, spring lockwasher
- 2 Hose clamp
- 3 Exhaust end section

Mounting silencer and exhaust end section

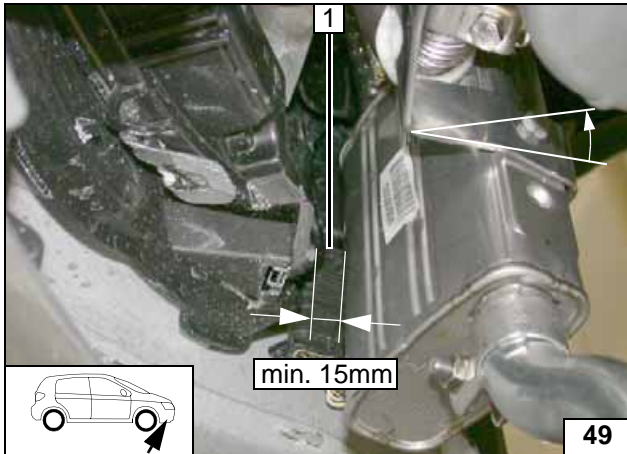
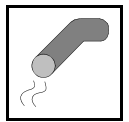

Ensure sufficient distance from neighbouring components, align bracket if necessary. Minimum distance between bracket of daytime running light and silencer at position **1** must be observed



Aligning silencer

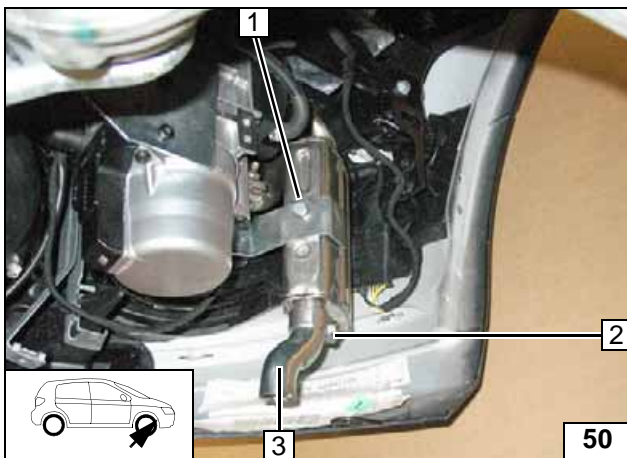

Vehicle with front fog light

Ensure sufficient distance from neighbouring components, correct if necessary. Slide exhaust end section **3** onto exhaust silencer (not completely, leave 5 mm distance between end section **3** and silencer), align and fasten.



Mounting silencer and exhaust end section

- 1 M6x12 bolt, spring lockwasher
- 2 Hose clamp

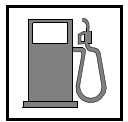

Fuel

CAUTION!

Open the vehicle's fuel tank cap, ventilate the tank and then re-close the tank lock.

Catch any fuel running off in an appropriate container.

Route fuel line and metering pump wiring harness so that they are protected against stone impact. Unless specified otherwise, always fasten using cable ties. Provide rub protection for fuel line and wiring harness in areas where there are sharp edges.

WARNING!

The fuel line and wiring harness are routed to the metering pump as shown in the wiring harness routing diagram.

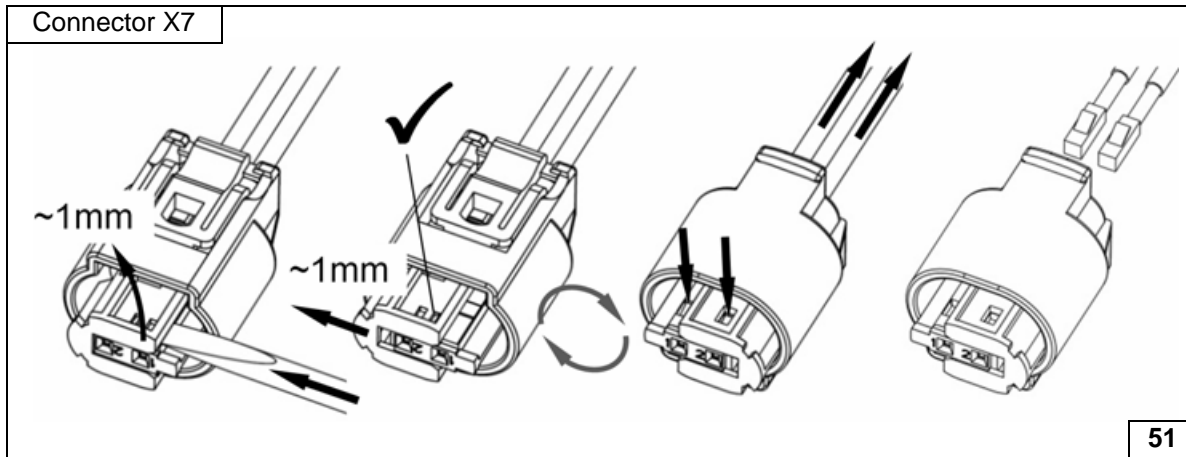

Removing metering pump connector

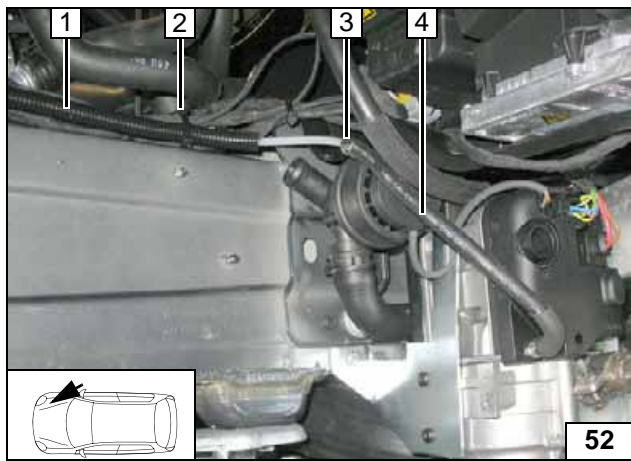

- 1 9 mm dia. corrugated tube, wiring harness of metering pump
- 2 Cable tie
- 3 Fuel line, 10 mm dia. clamp
- 4 Moulded hose of heater

Connection of heater

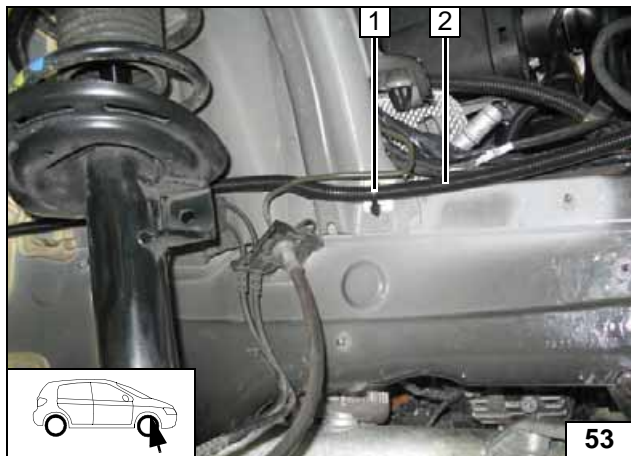

Degrease adhesive surface for adhesive base 1.

- 1 Adhesive base, cable tie
- 2 Corrugated tube



Routing lines

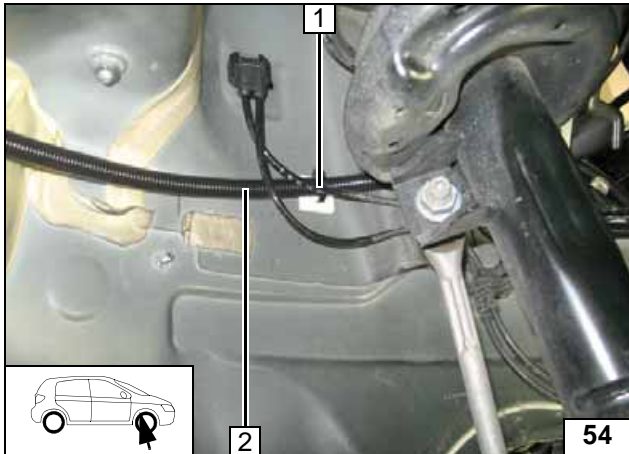
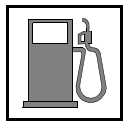

Degrease adhesive surface for adhesive base 1.

- 1 Adhesive base, cable tie
- 2 Corrugated tube



Routing lines

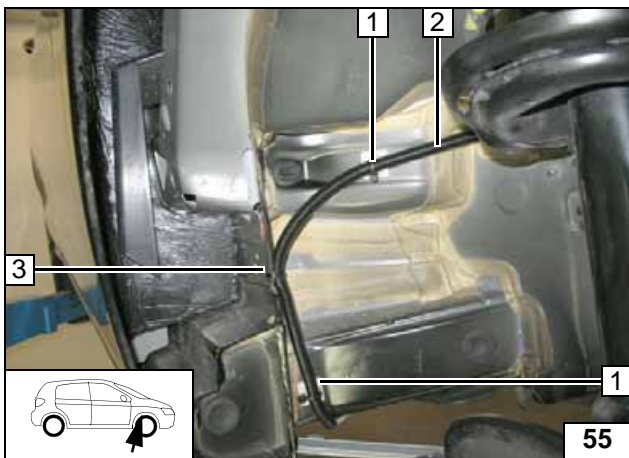

Degrease adhesive surface for adhesive base 1.

- 1 Adhesive base [2x], cable tie [2x]
- 2 Corrugated tube
- 3 Cable tie, existing hole



Routing lines

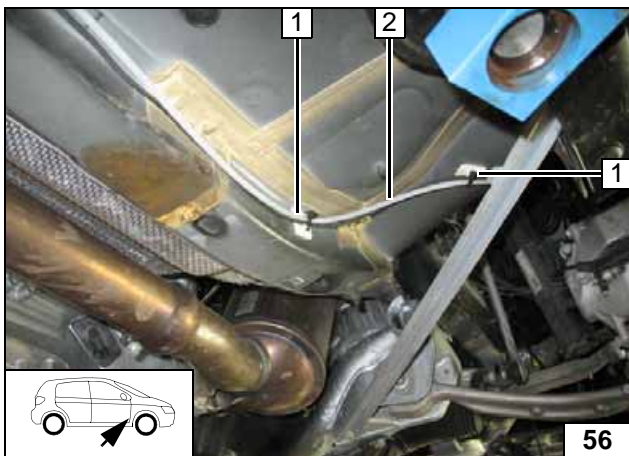

Degrease adhesive surface for adhesive base 1.

- 1 Adhesive base [2x], cable tie [2x]
- 2 Fuel line, wiring harness of metering pump



Routing lines

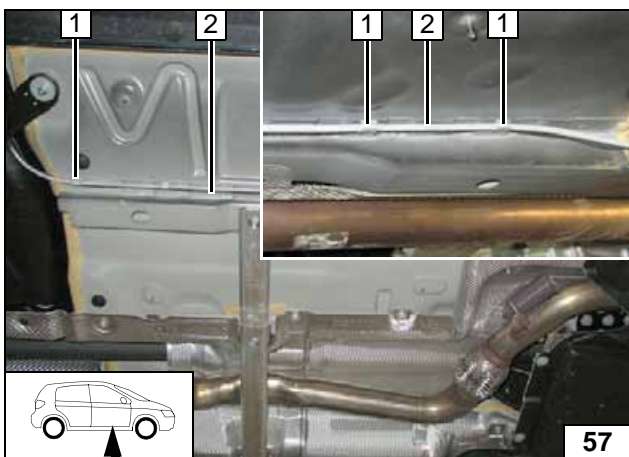

Distribute retaining clamps 1 [10x] evenly along vehicle underbody and insert fuel line 2 and wiring harness of metering pump.



Routing lines

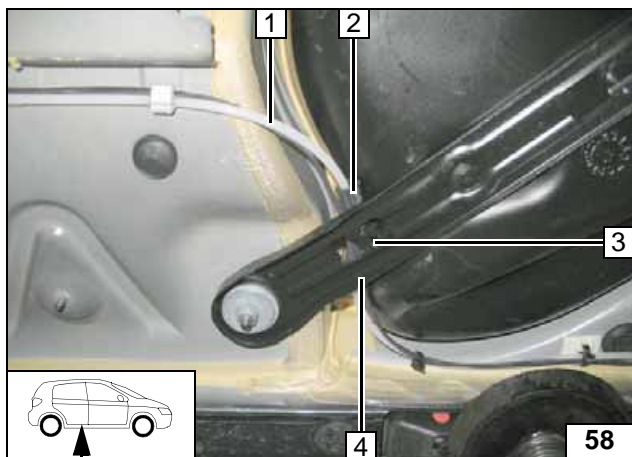
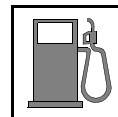

- 1 Fuel line, wiring harness of metering pump
- 2 Hose section 8x12 dia.
- 3 Cable tie
- 4 Original vehicle retaining strap

Routing lines

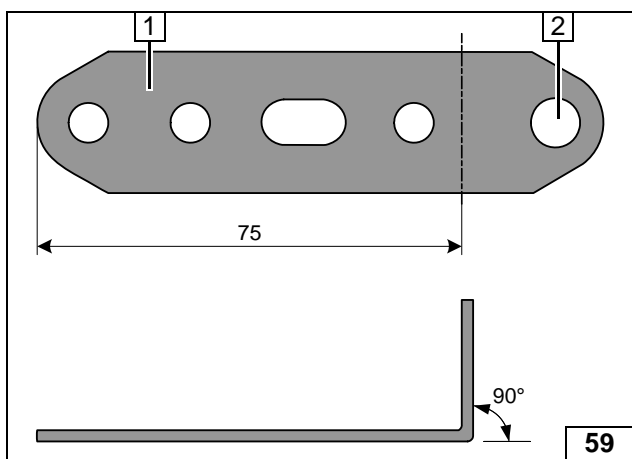

Angle down perforated bracket 1 and drill hole at position 2 to 8.5mm dia.



Preparing perforated bracket

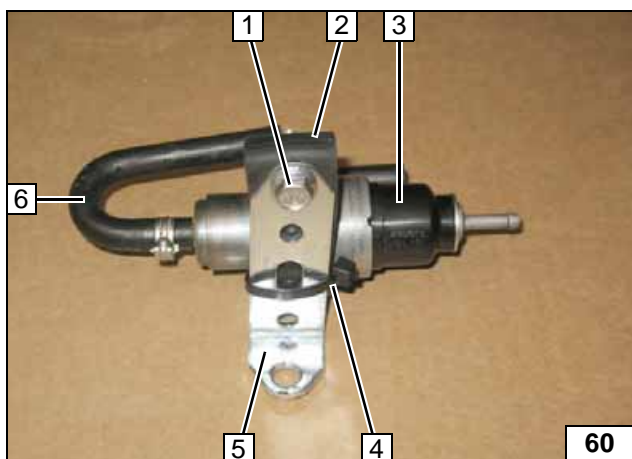

- 1 M6x25 bolt, flanged nut
- 2 Metering pump support
- 3 Metering pump
- 4 Cable tie
- 5 Perforated bracket
- 6 180° moulded hose, 10 mm dia. clamp

Premounting metering pump

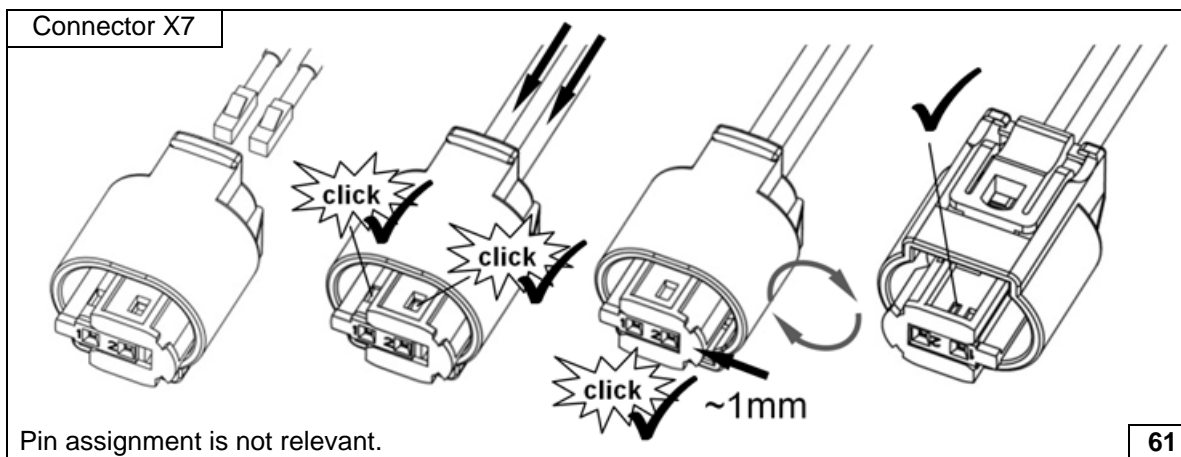

Completing connector of metering pump

Pin assignment is not relevant.

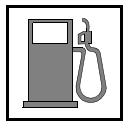

Mounting metering pump



Fuel extraction



Cutting standpipe to size



Premounting standpipe

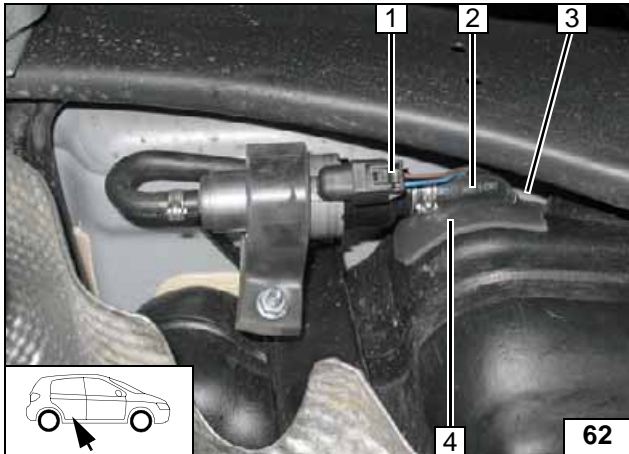

Mount perforated bracket on original vehicle bolt of fuel tank fastening. Paste insulation strip 4.

- 1 Wiring harness of metering pump, connector X7 mounted
- 2 Moulded hose 90°, 10 mm dia. clamp[2x]
- 3 Fuel line

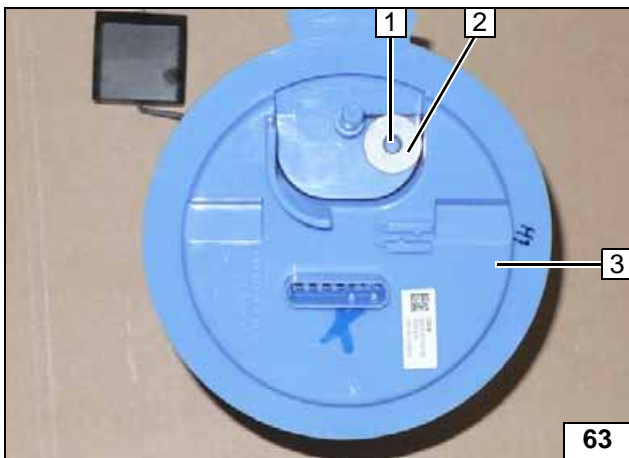

Remove fuel-tank sending unit 3 in accordance with manufacturer's instructions. Place large diameter washer 2 flush against the edges as shown, copy hole pattern 1.

- 1 6 mm dia. hole

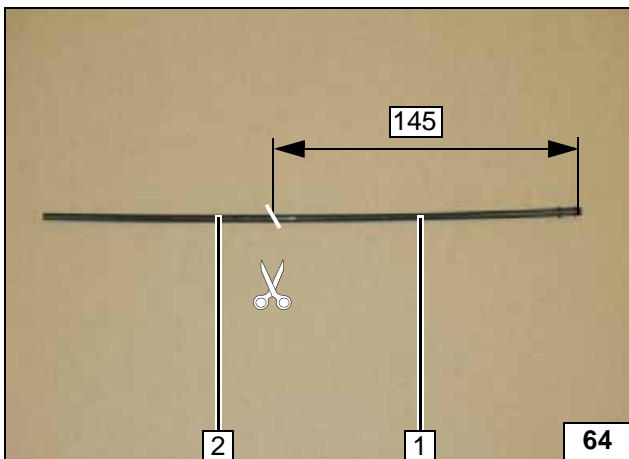

Cut standpipe 1 at an angle.

- 2 Section, discard

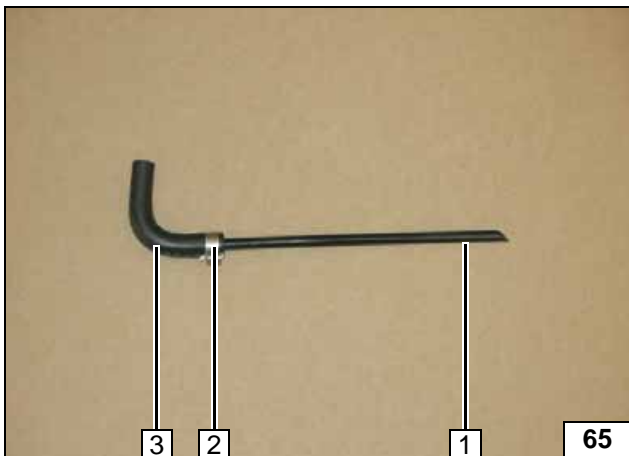

Mount standpipe 1 in 4.5 mm dia. moulded hose 3.

- 2 10mm dia. clamp

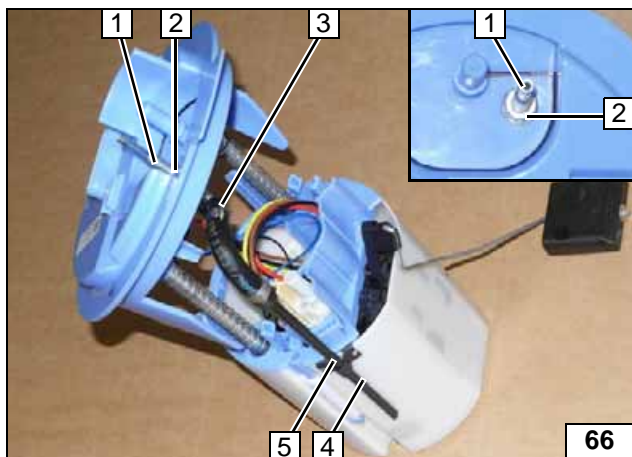
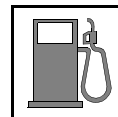

Observe 5Nm tightening torque on flanged nut **2**.

- 1** Fuel standpipe
- 3** 8 mm dia. clamp
- 4** Standpipe (premounted)
- 5** Retaining clamp



Installing fuel stand-pipe

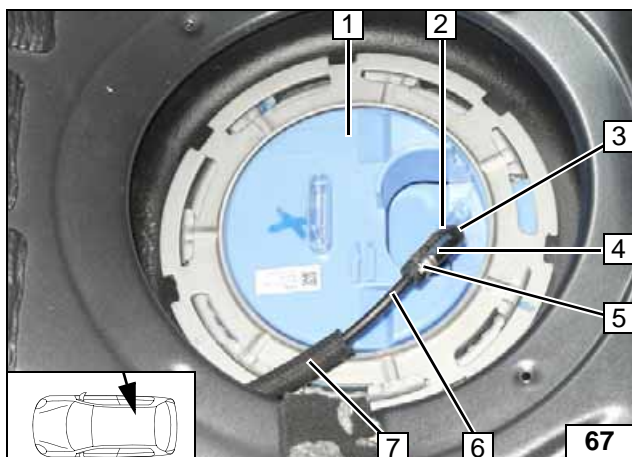

Mount fuel-tank sending unit **1** in accordance with manufacturer's instructions. Mount 3.5 mm dia. moulded hose **4** on fuel standpipe **2**.

- 3** 8 mm dia. clamp
- 5** 10 mm dia. clamp
- 6** Fuel line of metering pump
- 7** Fabric-reinforced hose (rattle protection)



Mounting fuel line

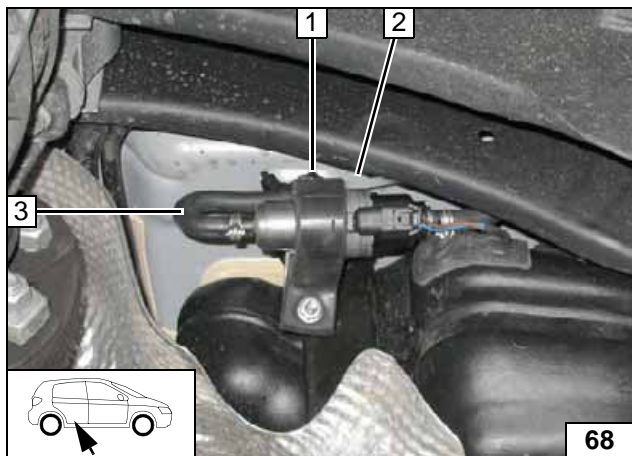

Ensure sufficient distance from neighbouring components, correct if necessary.

- 1** 10 mm dia. clamp
- 2** Fuel line
- 3** 180° moulded hose



Connec-tion of me-tering pump







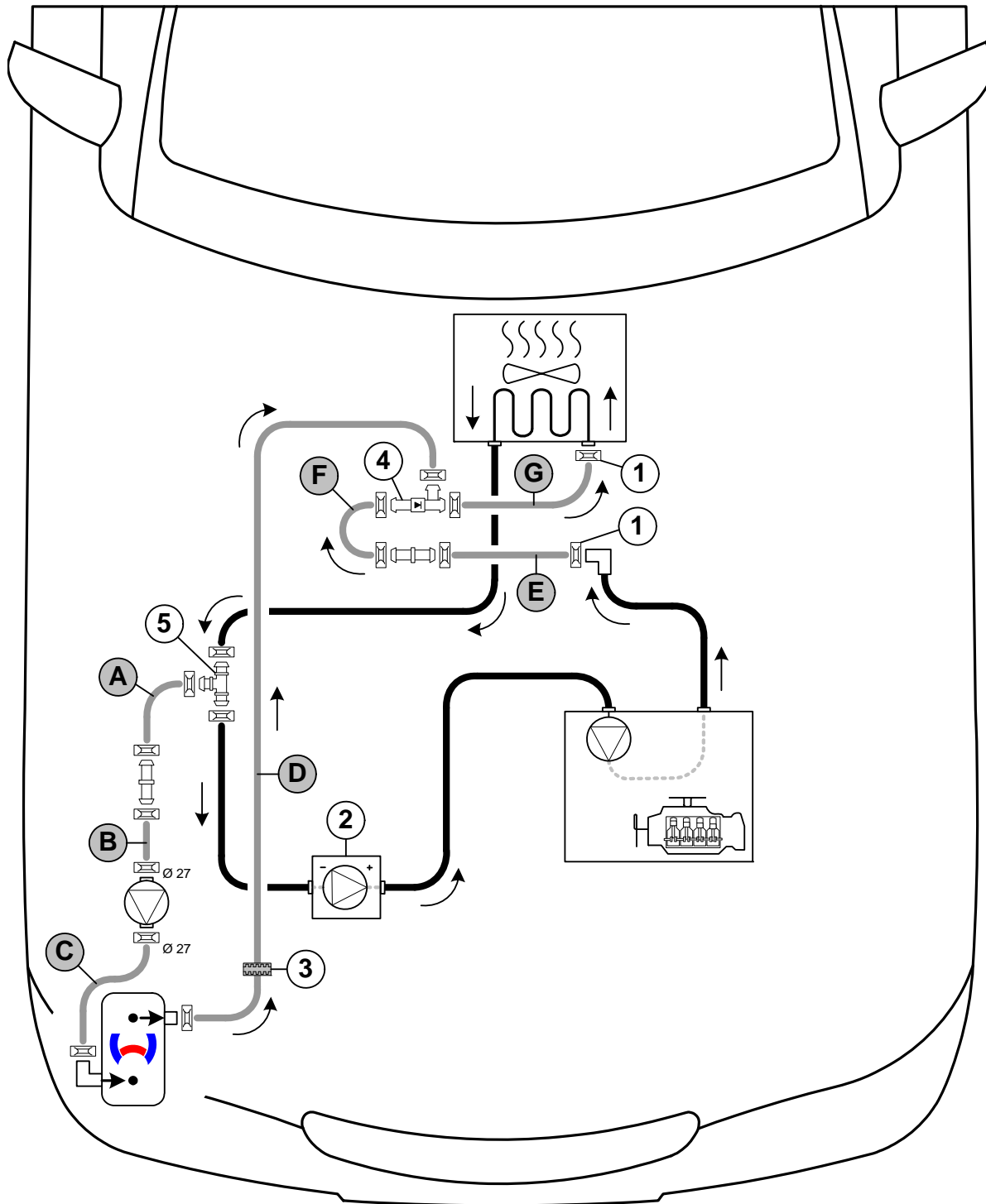

Coolant Circuit

WARNING!

Any coolant running off should be collected using an appropriate container. Install hoses so that they are kink-free. Unless specified otherwise, always fasten using cable ties. Position clamps so that no other hose can be damaged. When installing the hoses, the heater must be filled with coolant. The connection should be modelled on an "island" circuit and based on the following diagram:



Hose routing diagram

All spring clips without a specific designation  = 25 mm dia. **1** = Original vehicle spring clip 
2 = Original vehicle residual heat pump **3** = Black (sw) rubber isolator 
 All connecting pipes  and  = 18x18mm dia. **4** = check valve  **5** = T-piece .



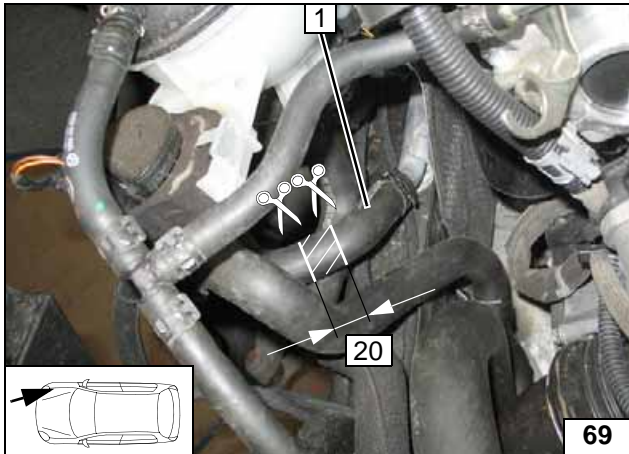

Cut off original vehicle hose 1 at the markings [2x].



2 Discard section

Cutting point

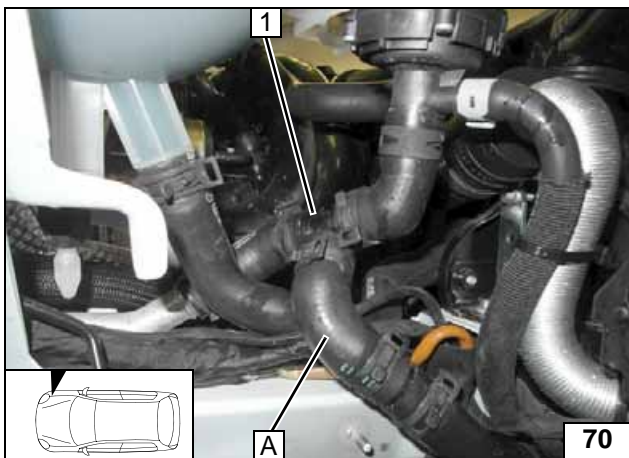

Mount T-piece 1 into cutting point.



Installing T-piece

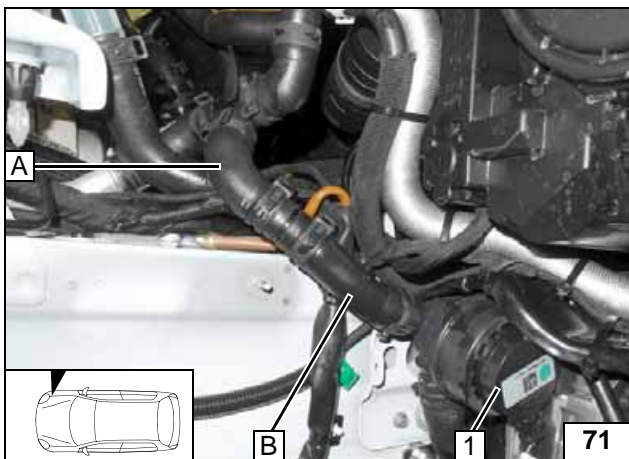

1 Circulating pump

Connection of circulating pump

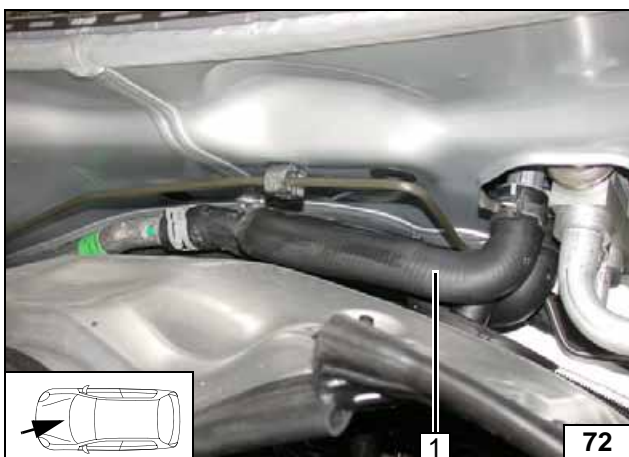

Remove original vehicle hose 1 and discard. Original vehicle spring clips will be reused.



Cutting point

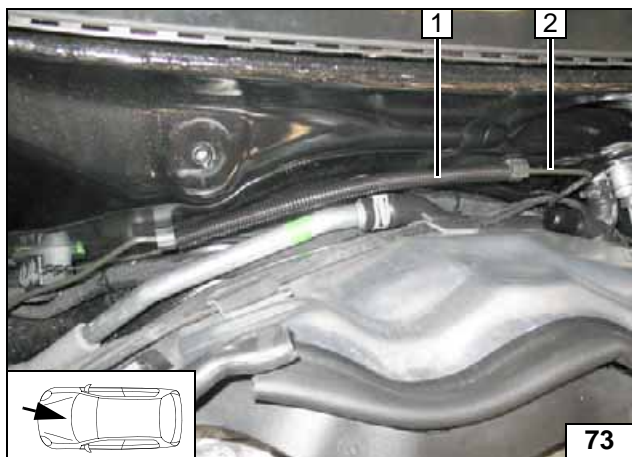

Slit 10mm dia. 250 mm long corrugated tube **1** lengthwise and slide between the brackets onto brake line **2**.



Mounting corrugated tube

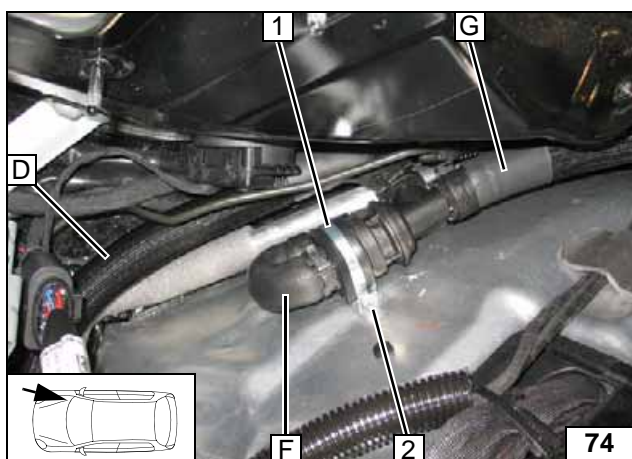

Hole 4,5mm dia at position **2**. When drilling, watch components located behind. Route hose **G** and **E** (hose **E** hidden by hose **G**) to cutting point. Align check valve horizontally. Check available space for trim.



Mounting hose group

- 1** 34 mm dia. rubber-coated p-clamp
- 2** 5.5x13 self-tapping screw

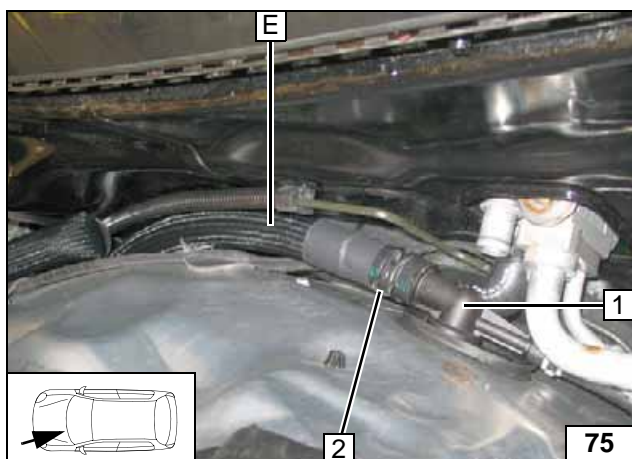

- 1** Coupling piece of engine outlet
- 2** Original vehicle spring clip

Connec-tion of en-gine outlet

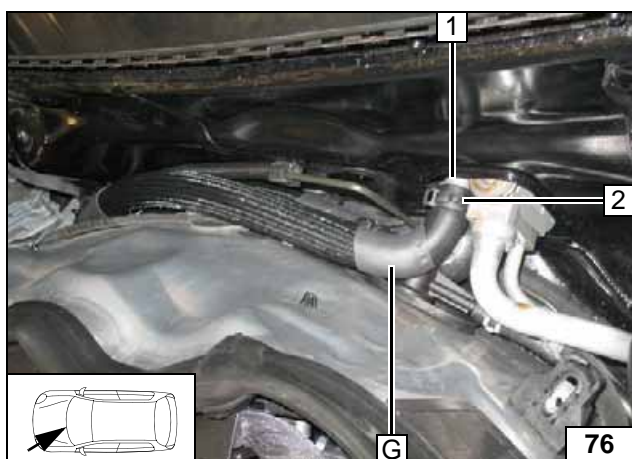

- 1** Connection piece on heat exchanger inlet
- 2** Original vehicle spring clip

Connect-ing heat ex-changer inlet

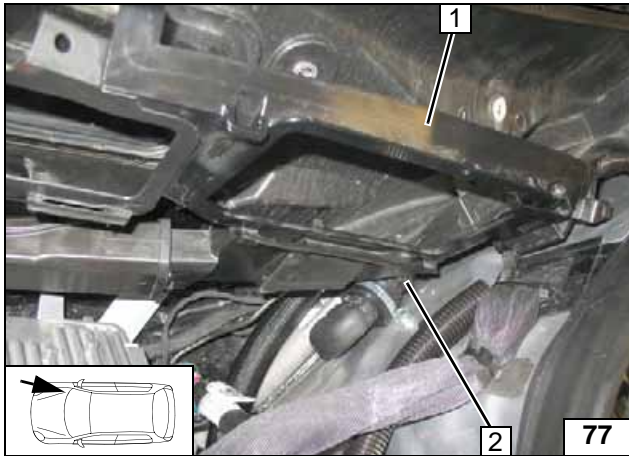

Ensure sufficient distance to check valve at position 2.



1 Trim

Mounting trim



1 Remove pass through and discard

Removing pass through

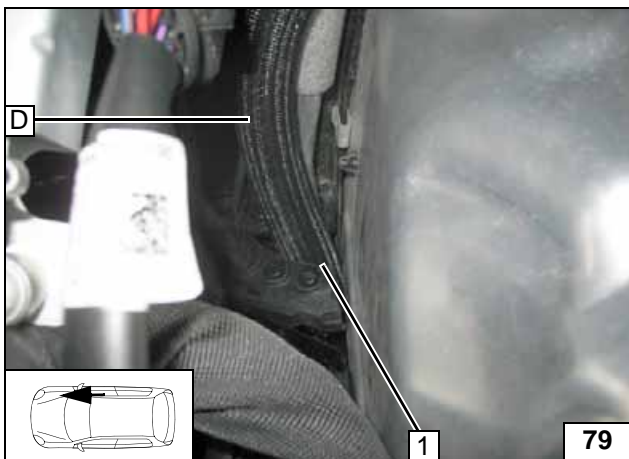

Route hose **D** through pass through at position 1 to heater.



Routing in engine compartment

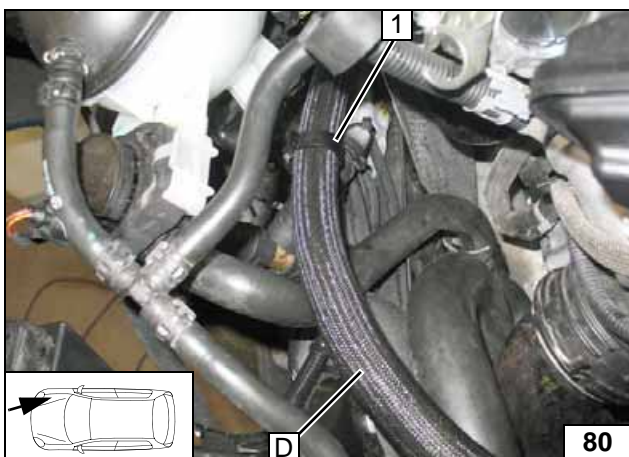

1 Hose bracket between hose **D** and original vehicle hose

Routing in engine compartment

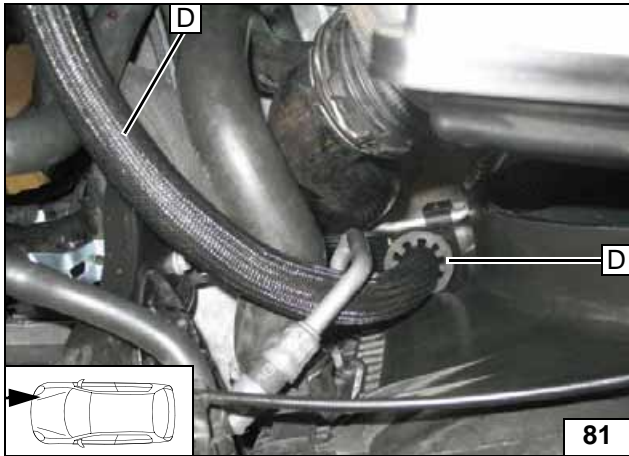

1 Black (sw) rubber isolator

Routing in engine compartment

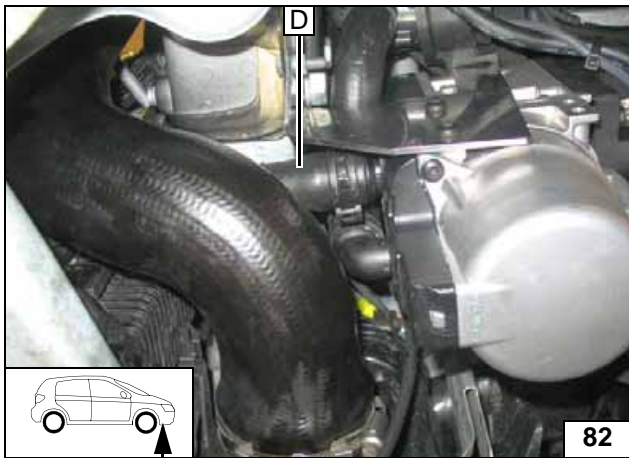

Align hoses. Ensure sufficient distance from neighbouring components, correct if necessary.



Connecting heater outlet

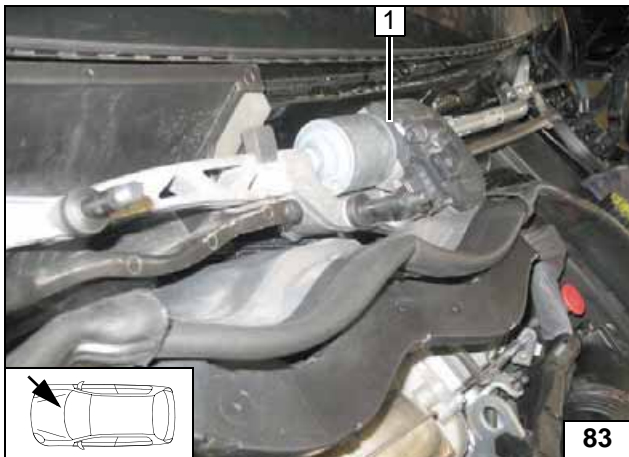

Mount wiper linkage 1. Ensure sufficient distance of hoses to wiper linkage 1 correct if necessary.



Mounting wiper linkage

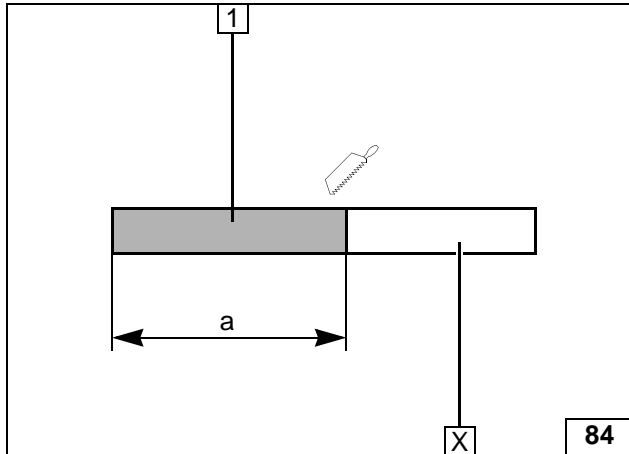
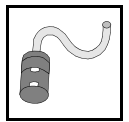

Combustion Air

Discard section X.

- 1 Combustion air pipe
a = 480



Cutting combustion air pipe to length

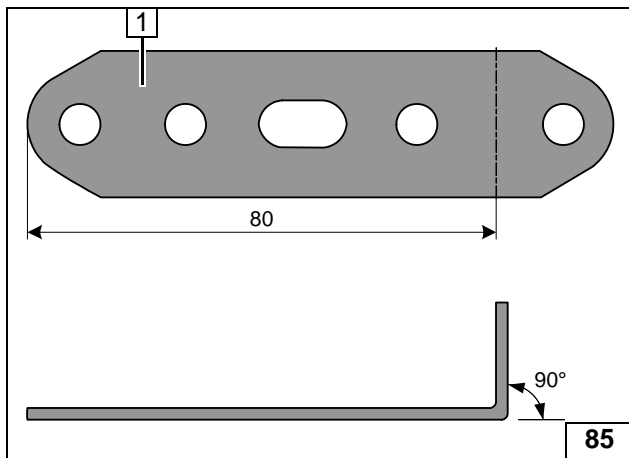

- 1 Perforated bracket



Angling down perforated bracket

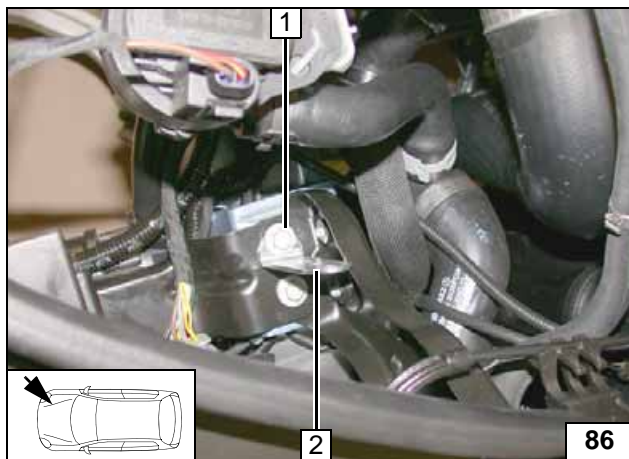

- 1 Original vehicle bolt
- 2 Angle bracket

Mounting angle bracket

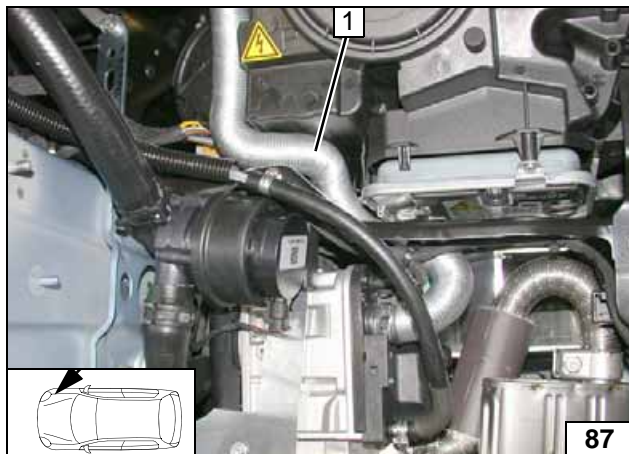

- 1 Combustion air pipe

Mounting combustion air pipe

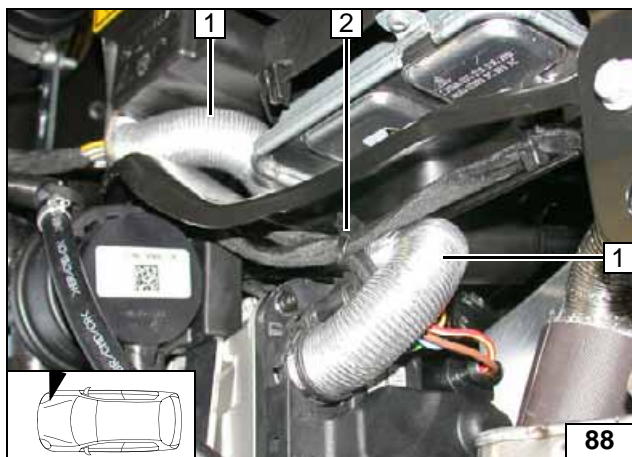
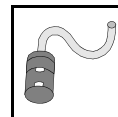

- 1 Combustion air pipe
- 2 Cable tie

**Routing
combustion
air pipe**

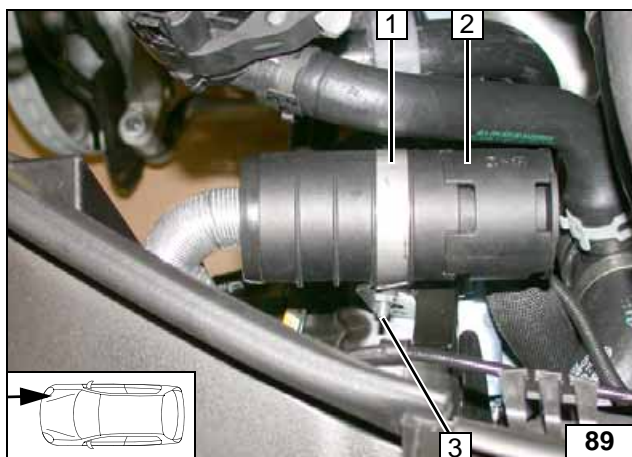

- 1 51 mm dia. p-clamp
- 2 Silencer
- 3 M5x20 bolt, flanged nut



**Mounting
silencer**

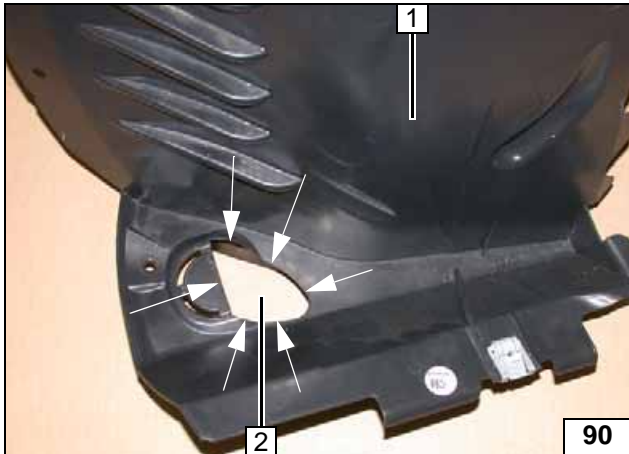
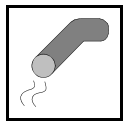

Exhaust End Section

Cut out wheel-well inner panel 1 at the markings.

2 Discard section



Cutting out wheel-well inner panel

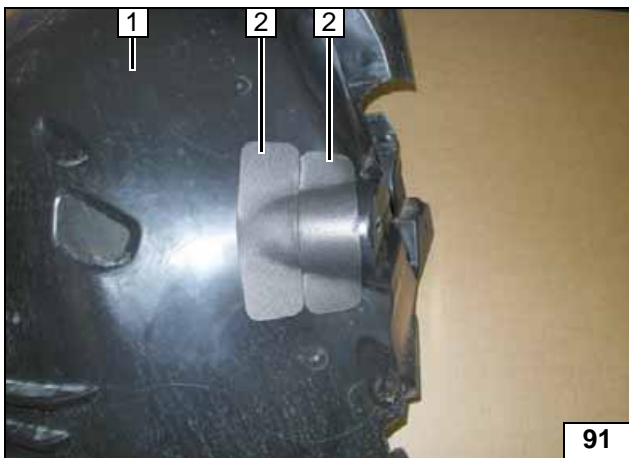

1 Wheel-well inner panel

2 Rub protection [2x]

Pasting on rub protection

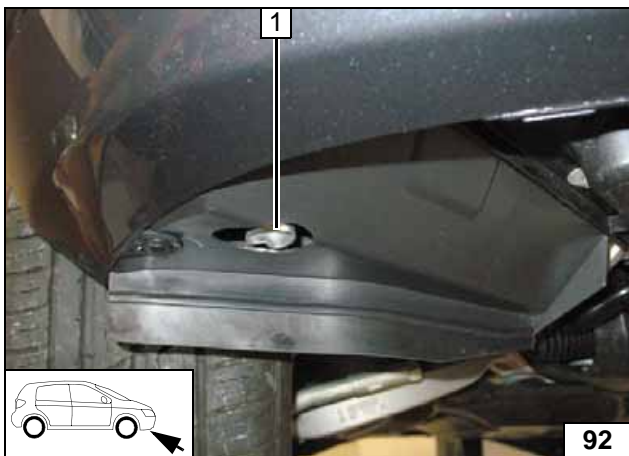

Install wheel-well inner panel. The exhaust end section 1, must be centred relative to the hole 1 and aligned flush with the wheel-well inner panel 2; realign exhaust end section 1 if necessary.



Aligning exhaust end section

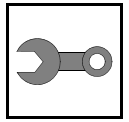

Final Work

WARNING!

Reassemble the disassembled components in reverse order. Check all hoses, clamps and all electrical connections for firm seating. Secure all loose wires using cable ties.

Only use manufacturer-approved coolant. Spray the heater components with anti-corrosion wax (Tectyl 100K, Order No. 111329).



- **Connect battery**
- **Fill and bleed the coolant circuit according to the vehicle manufacturer's instructions.**
- **Teach Telestart according to "Installation documentation T91 / T100 HTM", adjust digital timer if necessary**
- **Activate push button according to "Installation documentation T91 / T100 HTM" (Re-positioning of switch input)**
- **Define settings of A/C control panel according to the "operating and maintenance instructions of TT-Evo"**
- **Place caution label "Switch off parking heater before refuelling" in the area of the filler neck.**
- **For initial start-up and function check, see installation instructions**



WARNING:

After conducting an operating test of the parking heater, carry out an "input short test" with the "Diagnosis assistance system" of the manufacturer on the vehicle.

Reprogram the positioning motors in the KLA air conditioner.

