



Water Heater

Thermo Top Evo Parking Heater



With FuelFix

Installation Documentation Kia Sportage

Validity

| Manufacturer | Model | Type | EG BE No. / ABE |
|--------------|----------|------|------------------------------|
| Kia | Sportage | SL | e11 * 2007 / 46 * 0136 * ... |

| Motorisation | Fuel | Transmission type | Output in kW | Displacement in cm ³ | Engine code |
|--------------|--------|-------------------|--------------|---------------------------------|-------------|
| 1.6 GDI | Petrol | SG | 99 | 1591 | G4FD |
| 2.0 GDI | Petrol | SG | 122 | 1998 | G4NC |

SG = manual transmission

From model year 2014
Left-hand drive vehicle

Verified equipment variants: Automatic air-conditioning
Front fog lights
2 WD / 4 WD

Not verified: Manual air-conditioning
Passenger compartment monitoring

Total installation time: approx. 7.5 hours

Kia Sportage

Table of Contents

| | | | |
|--|----|---|----|
| Validity | 1 | Preparing Installation Location | 15 |
| Necessary Components | 2 | Preparing Heater | 15 |
| Installation Overview | 2 | Installing Heater | 19 |
| Information on Total Installation Time | 2 | Coolant Circuit 1.6 P | 20 |
| Information on Operating and Installation Instructions | 3 | Coolant Circuit 2.0 P | 22 |
| Information on Validity | 4 | Combustion Air | 24 |
| Technical Information | 4 | Fuel | 25 |
| Explanatory Notes on Document | 4 | Installing FuelFix | 27 |
| Preliminary Work | 5 | Exhaust Gas | 30 |
| Heater Installation Location | 5 | Final Work | 33 |
| Preparing Electrical System | 6 | Fuel Tank Sending Unit Template | 34 |
| Electrical System | 8 | FuelFix Template | 35 |
| Fan Controller | 9 | Operating Instructions for Automatic Air-Conditioning | 36 |
| Installation Instructions | 11 | | |
| MultiControl CAR Option | 14 | | |
| Remote Option (Telestart) | 14 | | |

Necessary Components

- Basic delivery scope of Thermo Top Evo in accordance with price list
- Installation kit with FuelFix for Kia Sportage 2014 Petrol: **1323068C**
- must also be ordered for automatic air-conditioning:
Automatic air-conditioning kit for Kia Sportage 2014: **1323066A**
- Heater control in accordance with price list and upon consultation with end customer
- In case of Telestart, indicator lamp in accordance with price list and in consultation with end customer

Installation instructions:

- Arrange for the vehicle to be delivered with the tank only about ¼ full.
- The installation location of the push button in case of Telestart or Thermo Call should be confirmed with the end customer.
- Depending on the space required and the vehicle manufacturer's instructions, we recommend the use of a vehicle battery with a higher electrical capacity.

Installation Overview

Legend:

1. Heater
2. Engine compartment fuse holder
3. Passenger compartment relay and fuse holder
4. Circulating pump
5. MultiControl CAR
6. Metering pump
7. FuelFix

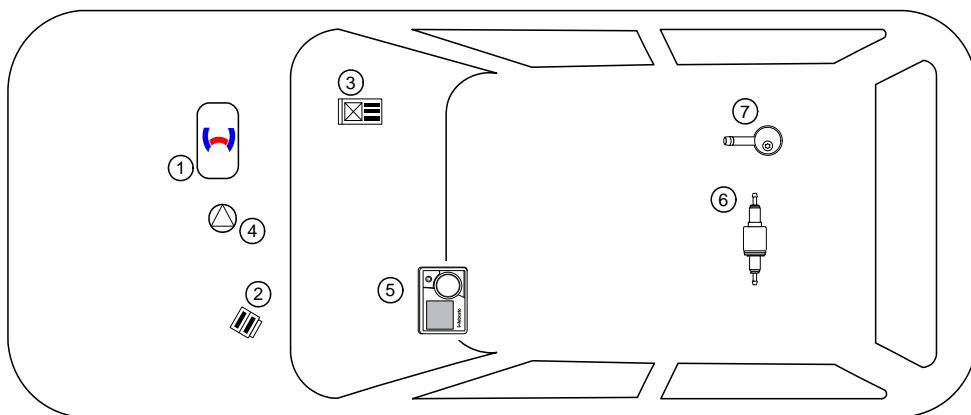

Information on Total Installation Time

The total installation time includes the time needed for mounting and demounting the vehicle-specific components, the heater specific installation time and all other times required for the system integration and initial start-up of the heater. The total installation time may vary for vehicle equipment other than provided.

Information on Operating and Installation Instructions

1 Important information (not complete)

1.1 Installation and repair



The improper installation or repair of Webasto heating and cooling systems can cause fire or the leakage of deadly carbon monoxide, leading to serious injury or death.



To install and repair Webasto heating and cooling systems you need to have completed a special company training course and have the appropriate technical documentation, special tools and special equipment.



Installation and repair may **ONLY** be carried out by persons trained and certified in a Webasto training course. **NEVER** try to install or repair Webasto heating or cooling systems if you have not completed a Webasto training course, you do not have the necessary technical skills and you do not have the technical documentation, tools and equipment available to ensure that you can complete the installation and repair work properly.

Only use genuine Webasto parts. See the Webasto air and water heaters accessories catalogue for this purpose.

1.2 Operation

To ensure safe operation, we recommend having the heater checked every two years by an authorised Webasto dealer, especially when used over a long period and/or under extreme environmental conditions.

Do not operate the heater in closed rooms due to the danger of poisoning and suffocation.

Always switch off the heater before refuelling.

The heater may only be used with the prescribed fuel diesel (DIN EN 590) or petrol (DIN EN 228).

The heater may not be cleaned with a high-pressure cleaner.

1.3 Please note

ALWAYS follow all Webasto installation and operating instructions and observe all warnings.

To become familiar with and understand all functions and properties of the heater, the operating instructions must be read carefully and observed at all times.

For proper, safe installation and repair work, the installation instructions with all warnings and safety information must be carefully read and observed at all times. Please always contact a workshop authorised by Webasto for all installation and repair work.

Important

Webasto shall assume no liability for defects, damage and injuries resulting from a failure to observe the installation, repair and operating instructions of the information contained in them.

This liability exclusion particularly applies to improper installations and repairs, installations and repairs by untrained persons or in the case of a failure to use genuine spare parts.

The liability due to culpable disregard to life, limb or health and due to damage or injuries caused by a wilful or reckless breach of duty remain unaffected, as does the obligatory product liability.

Installation should be carried out according to the general, standard rules of technology. Unless specified otherwise, fasten hoses, lines and wiring harnesses to original vehicle lines and wiring harnesses using cable ties. Insulate loose wire ends and tie back. Connectors on electronic components have to audibly click into place during installation.

Sharp edges should be fitted with rub protection. Spray unfinished body areas, e.g. drilled holes, with anti-corrosion wax (Tectyl 100K).

Observe the instructions and guidelines of the respective vehicle manufacturer for demounting and mounting vehicle specific components!

The initial startup is to be executed with the Webasto Thermo Test Diagnosis.

When installing a programmable control module (e.g. a PWM Gateway), the corresponding settings must be checked or adjusted.

2 Statutory regulations governing installation

| Guidelines | Thermo Top Evo |
|----------------------------|----------------|
| Heating Directive ECE R122 | E1 00 0258 |
| EMC Directive ECE R10 | E1 04 5627 |

Note

The regulations of these guidelines are binding in the scope of the Directive 70/156/EEC and/or 2007/46/EC (for new vehicle models from 29/04/2009) and should also be observed in countries in which there are no special regulations.

Important

Failure to follow the installation instructions will result in the invalidation of the type approval for the heater and therefore invalidation of the general **homologation of the vehicle**.

Note

The heater is licensed in accordance with paragraph 19, section 3, No. 2b of the StVZO (German Road Traffic Licensing Authority).

2.1 Excerpt from ECE regulation 122 (heating system) paragraph 5 for the installation of the heater

Beginning of excerpt.

ANNEX VII

REQUIREMENTS FOR COMBUSTION HEATERS AND THEIR INSTALLATION

1. GENERAL REQUIREMENTS

1.7.1. A clearly visible tell-tale in the operator's field of view shall inform when the combustion heater is switched on or off.

2. VEHICLE INSTALLATION REQUIREMENTS

2.1. Scope

2.1.1. Subject to paragraph 2.1.2, combustion heaters shall be installed according to the requirements of this Annex.

2.1.2. Vehicles of category O having liquid fuel heaters are deemed to comply with the requirements of this Annex.

2.2. Positioning of heater

2.2.1. Body sections and any other components in the vicinity of the heater must be protected from excessive heat and the possibility of fuel or oil contamination.

2.2.2. The combustion heater shall not constitute a risk of fire, even in the case of overheating. This requirement shall be deemed to be fulfilled if the installation ensures an adequate distance to all parts and suitable ventilation, by the use of fire resistant materials or by the use of heat shields.

2.2.3. In the case of M2 and M3 vehicles, the heater must not be positioned in the passenger compartment. However, an installation in an effectively sealed envelope which also complies with the conditions in paragraph 2.2.2 may be used.

2.2.4. The label referred to in paragraph 1.4 or a duplicate, must be positioned so that it can be easily read when the heater is installed in the vehicle.

2.2.5. Every reasonable precaution should be taken in positioning the heater to minimise the risk of injury and damage to personal property.

2.3. Fuel supply

2.3.1. The fuel filler must not be situated in the passenger compartment and must be provided with an effective cap to prevent fuel spillage.

2.3.2. In the case of liquid fuel heaters, where a supply separate to that of the vehicle is provided, the type of fuel and its filler point must be clearly labelled.

2.3.3. A notice, indicating that the heater must be shut down before refuelling, must be affixed to the fuelling point. In addition a suitable instruction must be included in the manufacturer's operating manual.

2.4. Exhaust system

2.4.1. The exhaust outlet must be located so as to prevent emissions from entering the vehicle through ventilators, heated air inlets or opening windows.

2.5. Combustion air inlet

2.5.1. The air for the combustion chamber of the heater must not be drawn from the passenger compartment of the vehicle.

2.5.2. The air inlet must be so positioned or guarded that blocking by rubbish or luggage is unlikely.

2.6. Heating air inlet

2.6.1. The heating air supply may be fresh or recirculated air and must be drawn from a clean area not likely to be contaminated by exhaust fumes emitted either by the propulsion engine, the combustion heater or any other vehicle source.

2.6.2. The inlet duct must be protected by mesh or other suitable means.

2.7. Heating air outlet

2.7.1. Any ducting used to route the hot air through the vehicle must be so positioned or protected that no injury or damage could be caused if it were to be touched.

2.7.2. The air outlet must be so positioned or guarded that blocking by rubbish or luggage is unlikely.

End of excerpt.

In multilingual versions the German language is binding.

Kia Sportage

Information on Validity

This installation documentation applies to Kia Sportage Petrol vehicles - for validity, see page 1 - from model year 2014 and later, assuming technical modifications to the vehicle do not affect installation, any liability claims excluded. Depending on the vehicle version and equipment, modifications may be necessary during installation with respect to this 'installation documentation'.

Vehicle and engine types, equipment variants and other specifications not listed in this installation documentation have not been tested. However, installation according to this installation documentation may be possible.

Technical Information

Special Tools

- Hose clamp pliers for auto-tightening hose clamps
- Hose clamp pliers for Clic hose clamps of type W
- Automatic wire stripper 0.2 - 6mm²
- Crimping pliers for cable lug / tab connector 0.5 - 6mm²
- Torque wrench for 2.0 - 10 Nm
- Hose clamping pliers
- Metric thread-setter kit
- Deep-hole marker
- Webasto Thermo Test Diagnosis with current software

Dimensions

- All dimensions are in mm.

Tightening torque values

- Tightening torque values of 5x13 heater bolts and 5x11 heater stud bolts = 8Nm.
- Tightening torque value of 5x15 water connection piece retaining plate bolt = 7Nm.
- Tighten other bolt connections in accordance with manufacturer's instructions or in accordance with state-of-the-art technology.

Explanatory Notes on Document

You will find an identification mark on the outside top right corner of the page in question to provide you with a quick overview of the individual working steps.

Special features are highlighted using the following symbols:

Mechanical System



Electrical System



Coolant Circuit



Combustion Air



Fuel



Exhaust Gas



Software



Specific risk of damage to components.



Specific risk due to electrical voltage.



Specific risk of injury or fatal accidents.



Specific risk of fire or explosion.



Reference to the manufacturer's vehicle-specific documents or to the general installation instructions of Webasto components.



Reference to a special technical feature.



The arrow in the vehicle icon indicates the position on the vehicle and the viewing angle.



Tightening torque according to the manufacturer's vehicle-specific documents.



Preliminary Work

Vehicle



- Open the fuel tank cap.
- Ventilate the fuel tank.
- Close the fuel tank cap again.
- Depressurise the cooling system.
- Disconnect the battery.
- Remove the windscreen wipers.
- Remove the coolant reservoir cap and the coolant reservoir.
- Remove the horn on the right on the spring dome.
- Remove the underride protection.
- Remove the underbody trim on the left before the fuel tank.
- Remove the seating surface of the rear bench seat.
- Open the tank-fitting service lid.
- Remove the glove box.
- Remove the door step trim on the front passenger's side.
- Remove the lower A-pillar trim in the front passenger's side footwell.
- Remove the upper A-pillar trim on the front passenger's side (only in case of Telestart).
- Remove the A/C control panel (see installation aid).



Heater

- Remove years that do not apply from the type and duplicate label.
- Attach the duplicate label (type label) visibly in the appropriate place in the engine compartment.

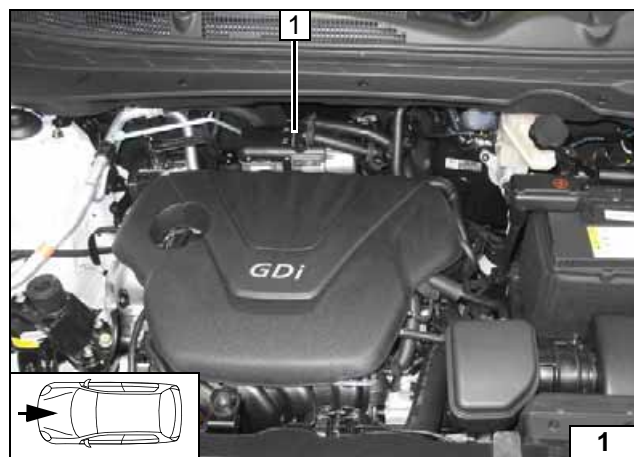

Heater Installation Location

- 1 Heater

Installation location

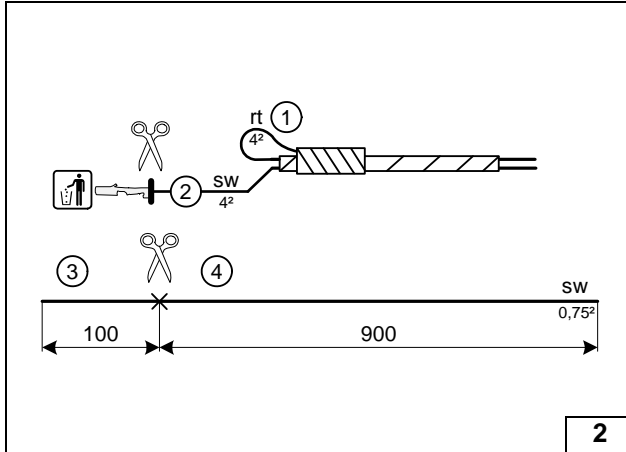

Preparing Electrical System

Wire sections retain their numbering in the entire document.

Produce all following electrical connections as shown in the wiring diagram.

- ① Insulate red (rt) wire of fan wiring harness and tie back.
- ② Black (sw) wire of K1/30, fan wiring harness



Preparing wires

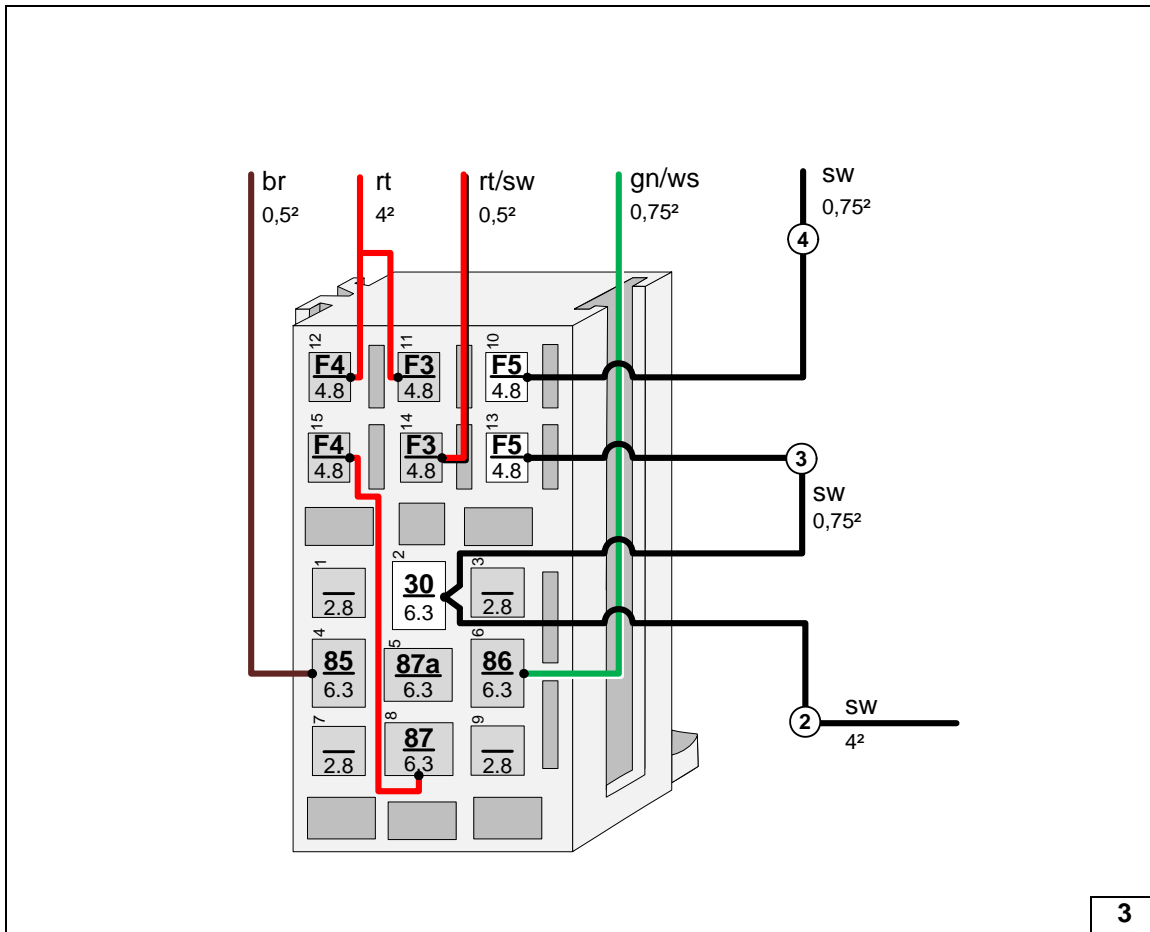

Connecting wires to passenger compartment relay and fuse holder

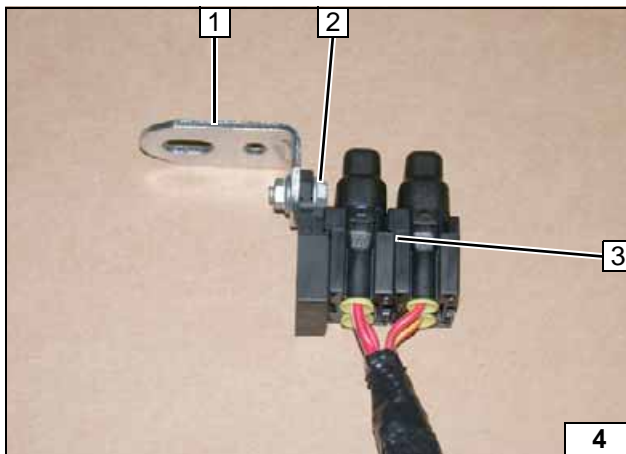

- 1 Angle bracket
- 2 M5x16 bolt, washer [2x], retaining plate of fuse holder, nut
- 3 Fuses F1-2 mounted

Preparing engine compartment fuse holder

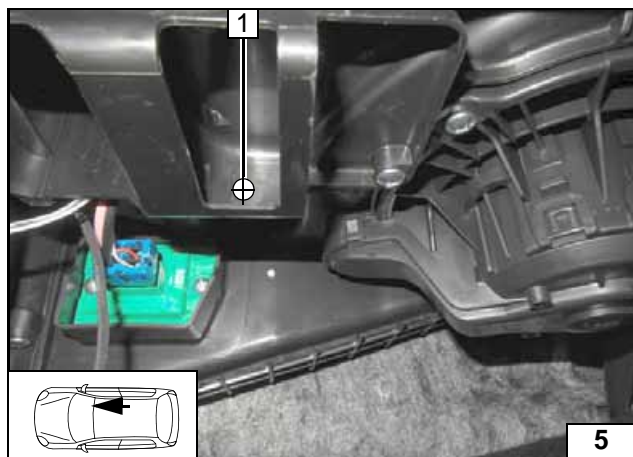

1 6mm dia. hole (short drill)

Hole for
passenger
compartment
relay
and fuse
holder



Electrical System



Wiring harness pass through

- 1 Wiring harnesses of heater and heater control
- 2 Protective rubber plug

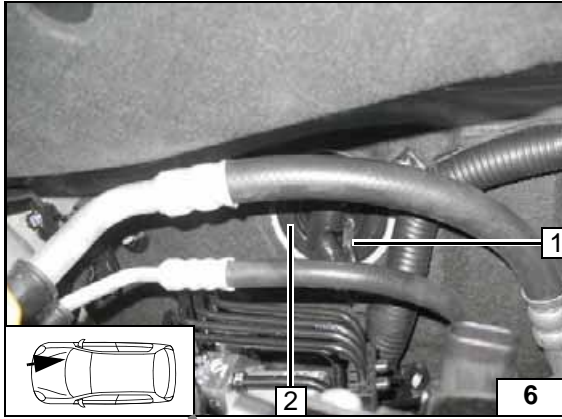

Engine compartment fuse holder

Position engine compartment fuse holder 1 at the installation location. The assembly should take place after the installation of the cover during the 'Final Work' phase.

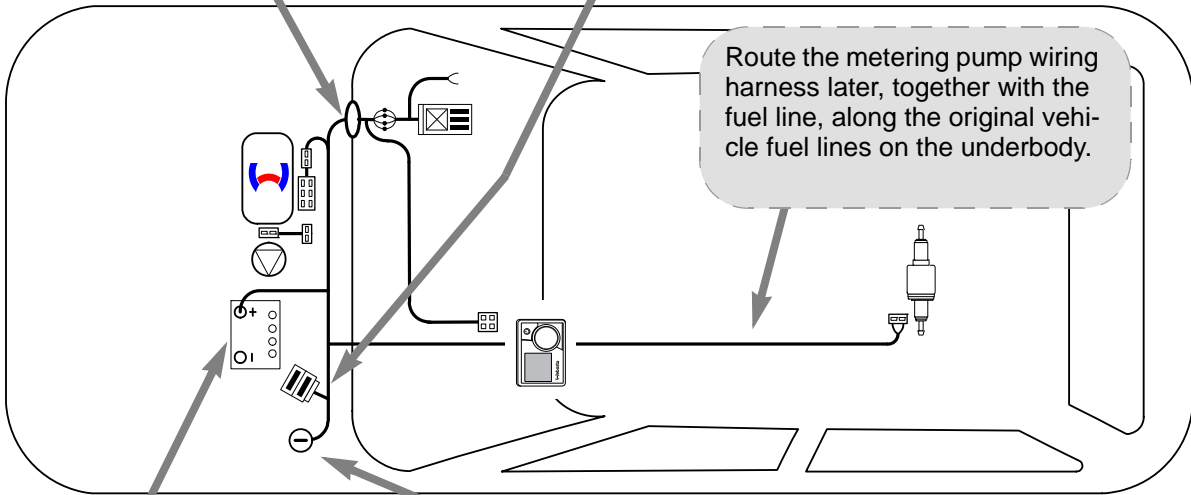
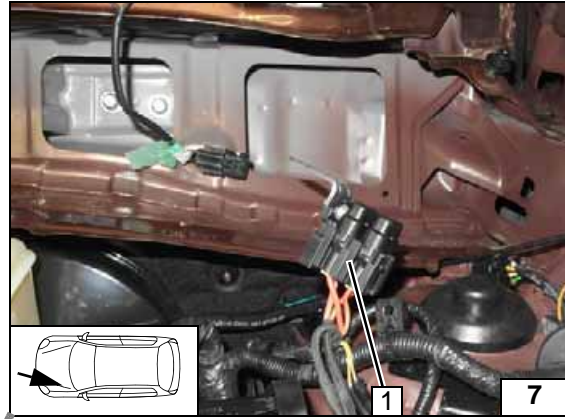

Wiring harness routing diagram

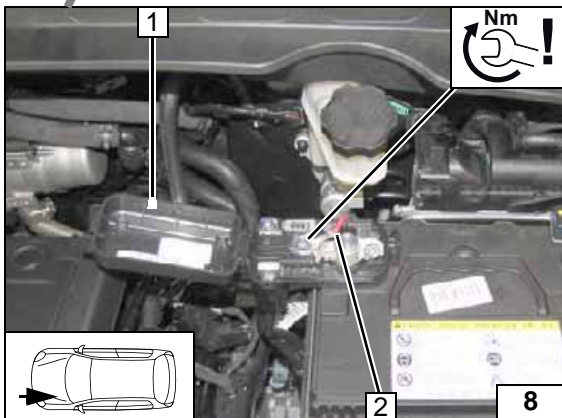

Positive wire

- 1 Nick positive terminal cover
- 2 Positive wire, original vehicle bolt

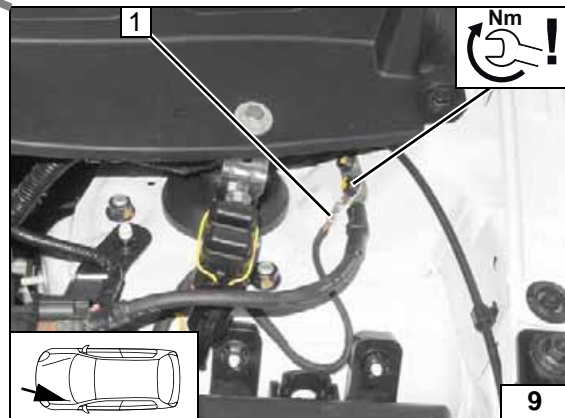

Earth connection

- 1 Earth wire on original vehicle earth support point





Fan Controller

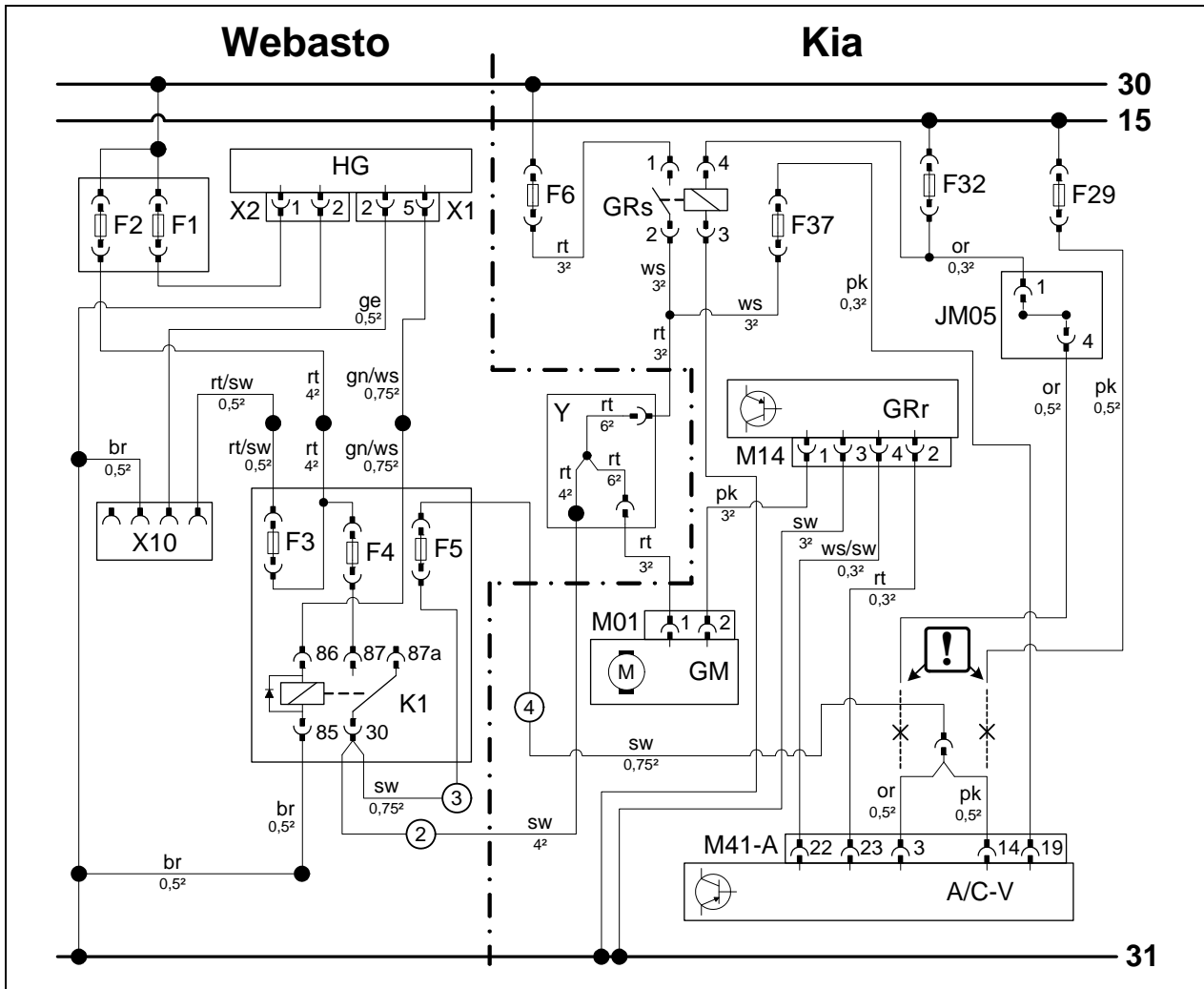

Wiring diagram

| Webasto components | | Vehicle components | | Colours and symbols | |
|--------------------|-----------------------------------|--------------------|---------------------------|--------------------------|---------------------------------|
| HG | TT-Evo heater | F6 | 40A fuse | rt | red |
| X1 | 6-pin heater connector | GRs | Fan relay | sw | black |
| X2 | 2-pin heater connector | F37 | 7.5A fuse | br | brown |
| F1 | 20A fuse | F32 | 10A fuse | gn | green |
| F2 | 30A fuse | F29 | 10A fuse | ws | white |
| Y | Adapter | JM05 | Connector | ge | yellow |
| X10 | 4-pin connector of heater control | GRr | Fan controller | pk | pink |
| F3 | 1A fuse | M14 | 4-pin connector of GRr | or | orange |
| F4 | 25A fuse | GM | Fan motor | | |
| F5 | 10A fuse | M01 | 2-pin connector of GM | | |
| K1 | Fan relay | A/C-V | A/C booster | ! | Insulate wire ends and tie back |
| | | M41-A | 26-pin connector of A/C-V | | |
| | | | | X | Cutting point |
| | | | | Wiring colours may vary. | |

Legend

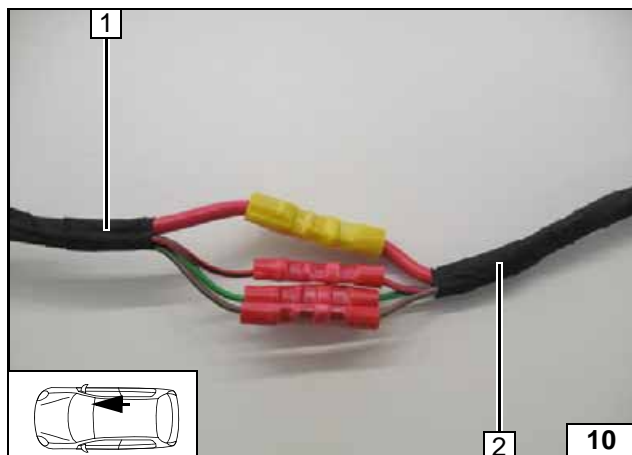

- 1 Passenger compartment relay and fuse holder wiring harness
- 2 Heater wiring harness

Connecting same colour wires of wiring harnesses

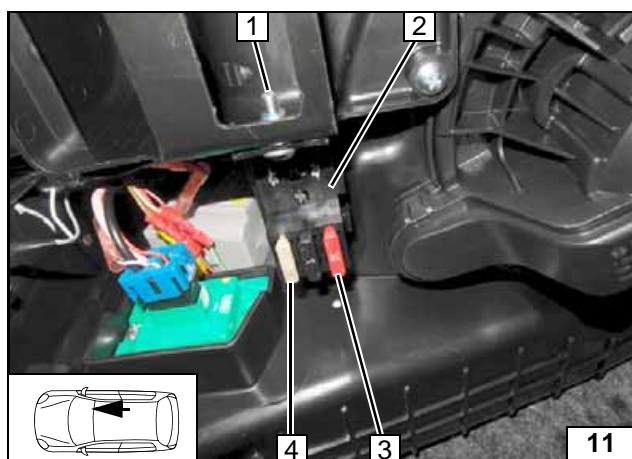

- 1 M5x16 bolt, large diameter washer [2x], nut
- 2 Passenger compartment relay and fuse holder
- 3 10A fuse F5
- 4 25A fuse F4

Installing passenger compartment relay and fuse holder and fuses

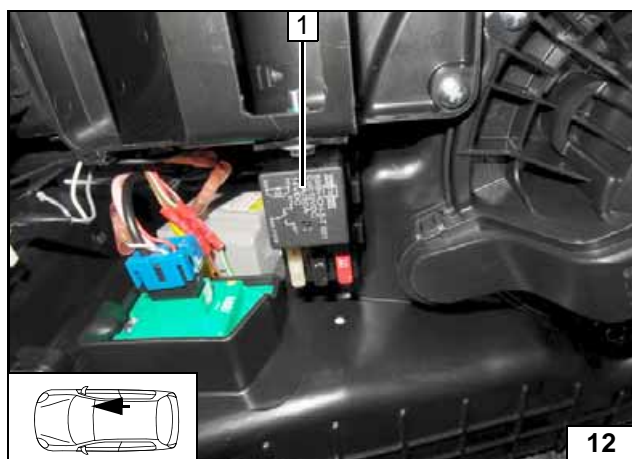

- 1 Relay K1

Installing relay K1

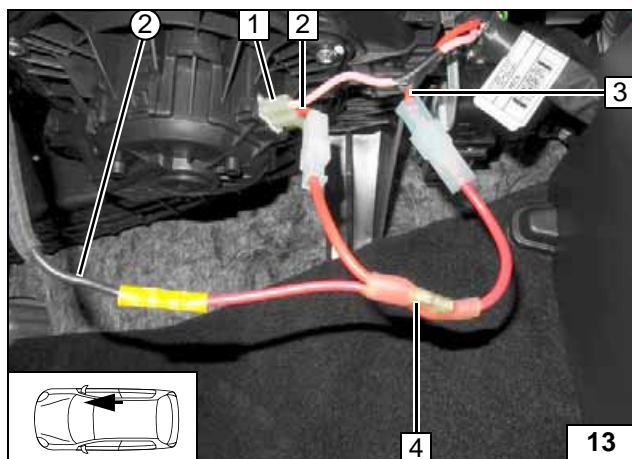

- 1 2-pin connector M01 of GM
- 2 Red (rt) wire from connector M01, pin 1
- 3 Red (rt) wire from fan relay
- 4 Y-Adapter
- ② Black (sw) wire of K1/30, fan wiring harness

Connecting fan motor

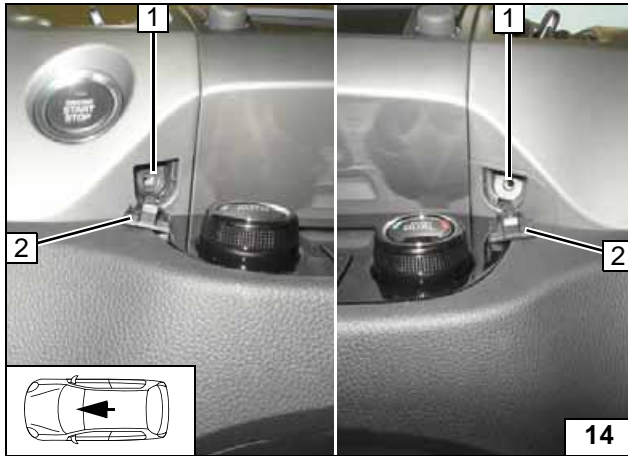

Installation Instructions

Remove cover **2** [2x]. Pre-cut thread at position **1** [2x]. Completely pull out steering wheel and then align downwards.



Detaching trim

- 1 Front passenger's side trim
- Fastening points (retaining clip) [8x]

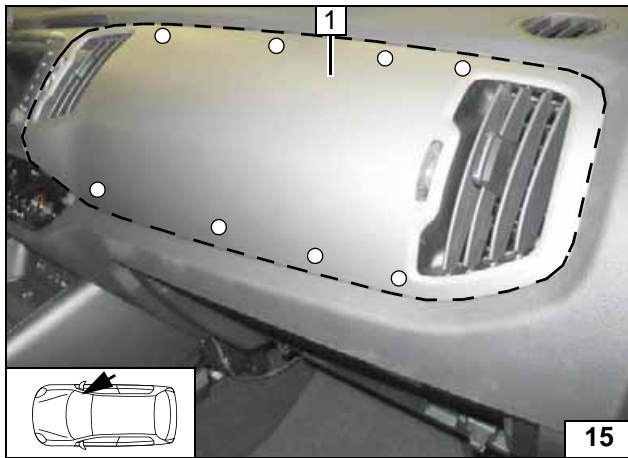

Removing trim

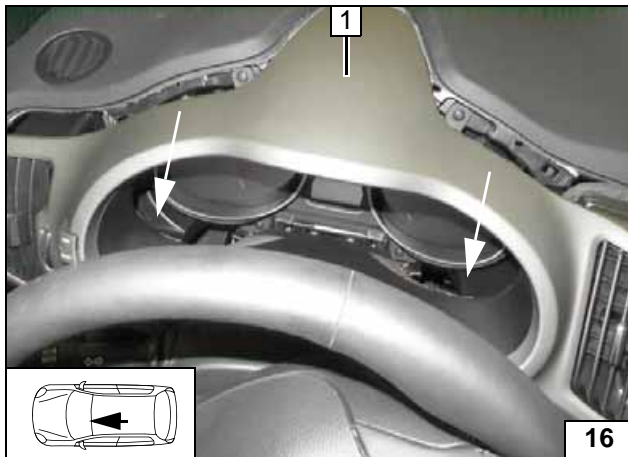

- 1 Cockpit trim

Removing trim

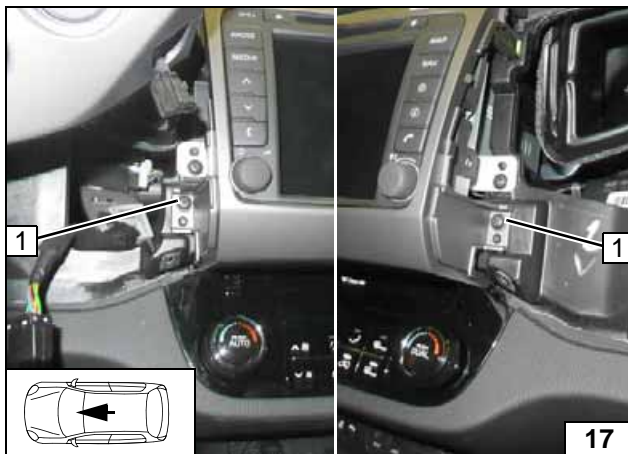

- 1 Remove bolt [2x] on both sides

Detaching and removing frame of multimedia system



1 Remove bolt [2x] on both sides

Detaching multimedia system

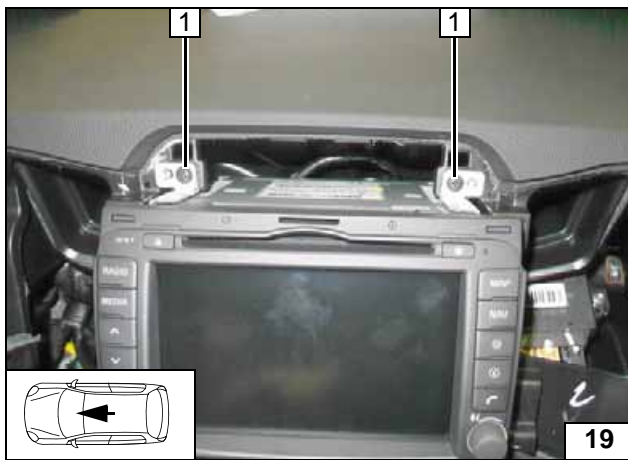

1 Remove bolt [2x]

Detaching multimedia system

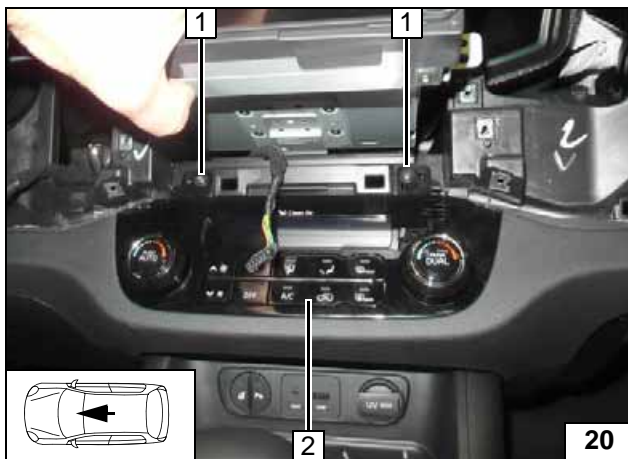

1 Remove bolt [2x]
2 A/C control unit

Detaching A/C control unit



Remove A/C control unit 2 using plastic wedges 1 [2x].



Removing A/C control unit

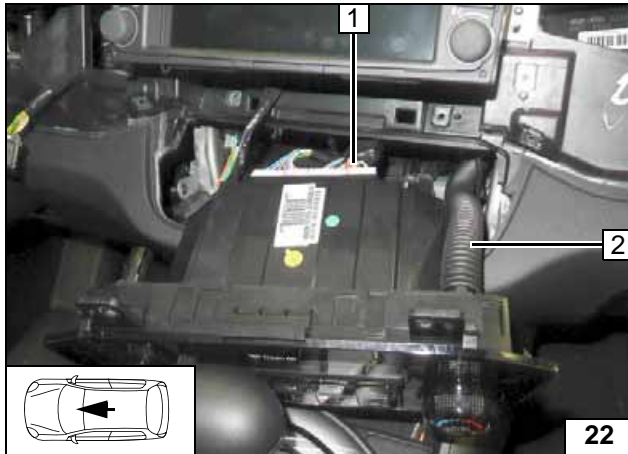
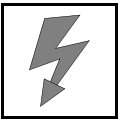

- 1 Connector M41-A
- 2 Pull off hose

Pulling out connector

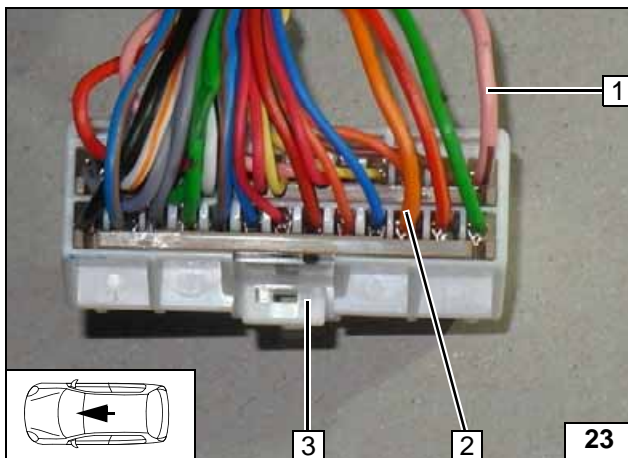

- 1 Pink (pk) wire, PIN 14
- 2 Orange (or) wire, pin 3
- 3 26-pin connector M41-A pulled out

View of connector M41-A

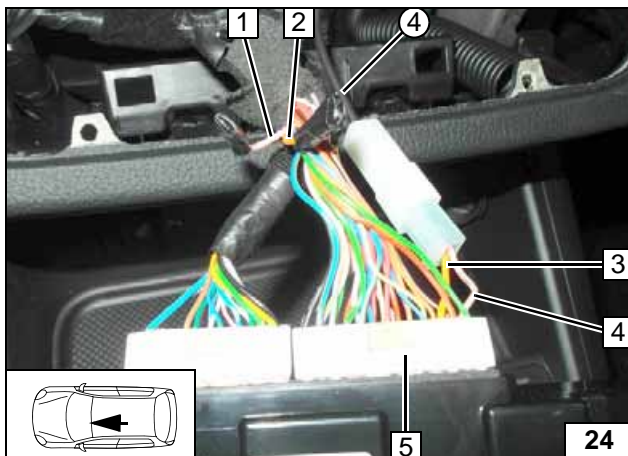

- 1 Pink (pk) wire of fuse F29
- 2 Orange (or) wire of fuse F32
- 3 Orange (or) wire of 26-pin connector M41-A, pin 3
- 4 Pink (pk) wire of 26-pin connector M41-A Pin 14
- 5 26-pin connector M41-A of A/C-V
- ④ Black (sw) wire of fuse F5

Connecting A/C booster

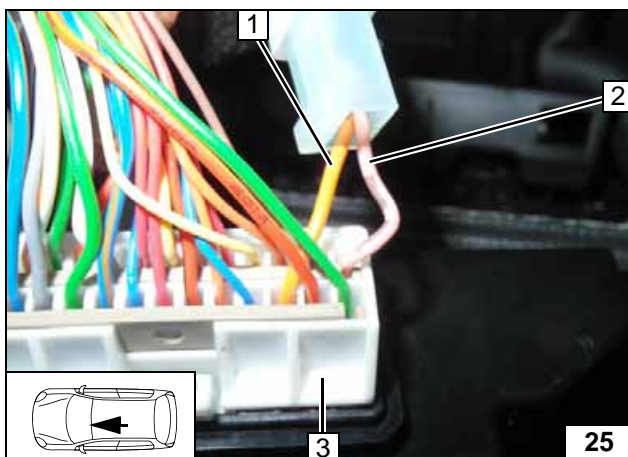

- 1 Orange (or) wire, pin 3
- 2 Pink (pk) wire, PIN 14
- 3 26-pin connector M41-A

View of connector M41-A

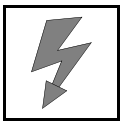

MultiControl CAR Option



Installing MultiControl CAR

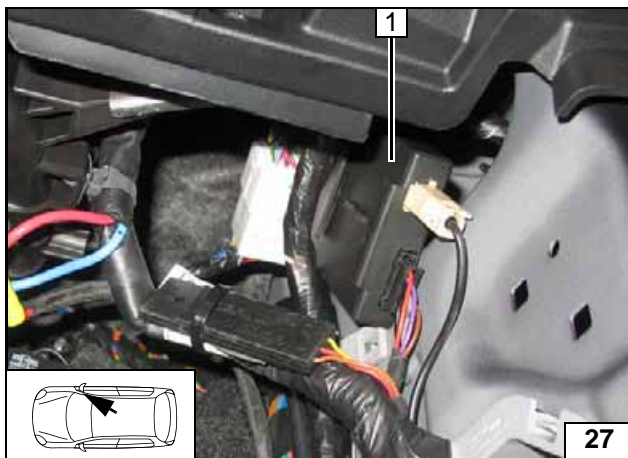

Remote Option (Telestart)



- 1 Fasten receiver with double-sided adhesive tape.

Installing receiver

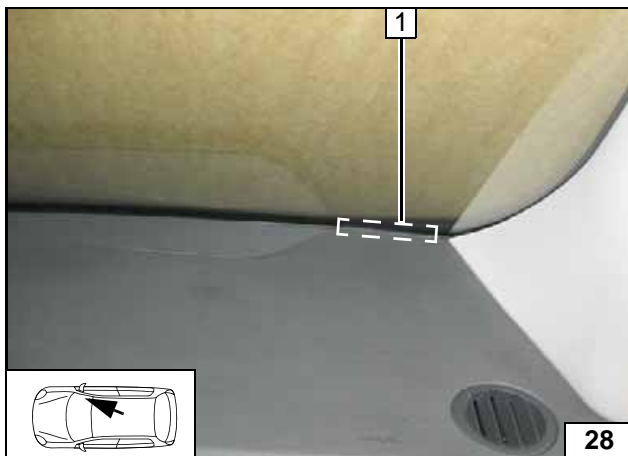

- 1 Aerial

Installing aerial

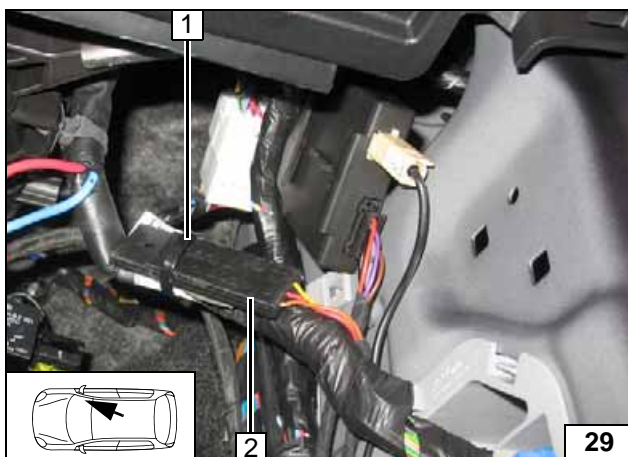

Only for Telestart T100 HTM



- 1 Cable tie
- 2 Temperature sensor

Installing temperature sensor

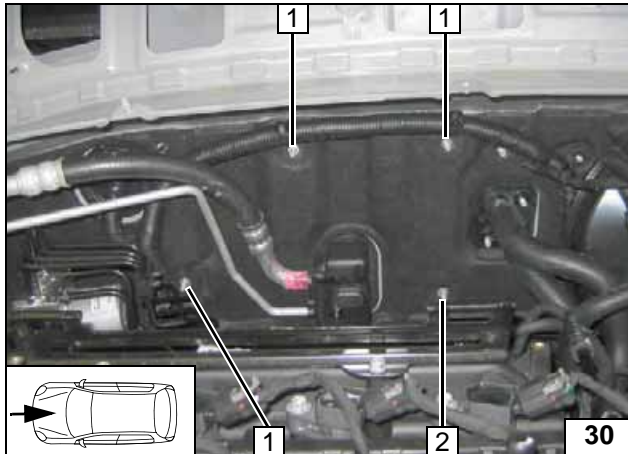
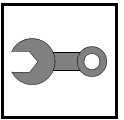

Preparing Installation Location

Unclip original vehicle wiring harness at position 1. Mount one washer each on stud bolts 1 [3x] and 2 (washers height compensation for insulation mat and bracket). Cut out a little insulation mat if necessary!



Copying hole pattern

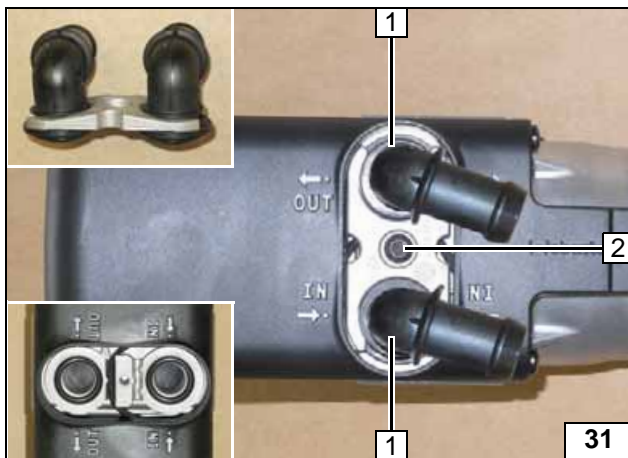

Preparing Heater

- 1 Water connection piece, sealing ring [2x each]
- 2 5x15 self-tapping bolt, retaining plate of water connection piece



Installing water connection piece

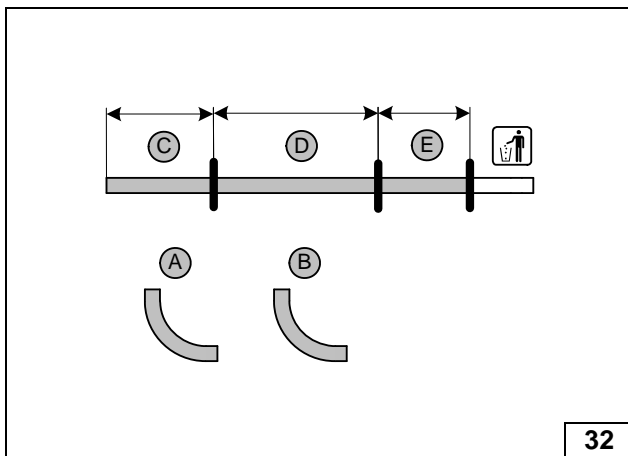

1.6 P

Hoses A and B = 90° moulded hoses

- C = 130
- D = 190
- E = 100



Cutting hoses to length

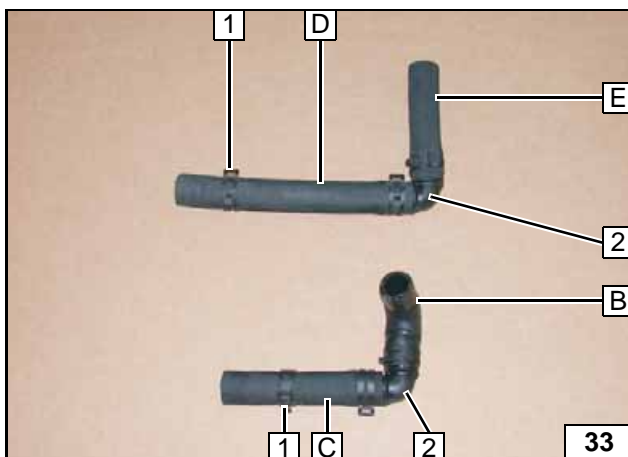

- 1 Slide on 25mm dia. spring clip [2x]
- 2 90° 18x18 mm [2x] connecting pipes, 25 mm dia. spring clip [4x]

Premounting hoses

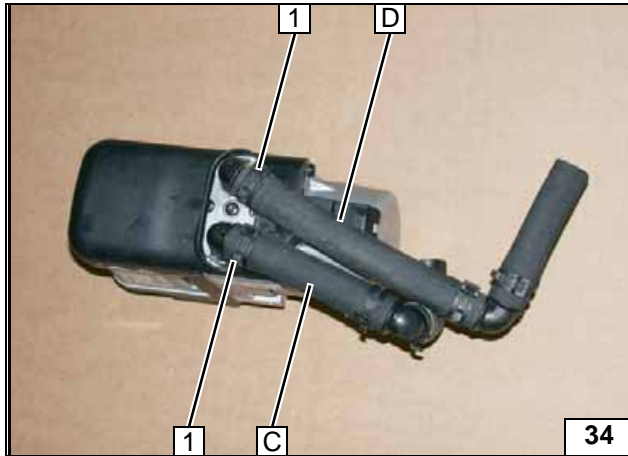
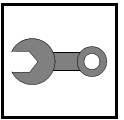

1 25mm dia. spring clip [2x]

Installing hoses

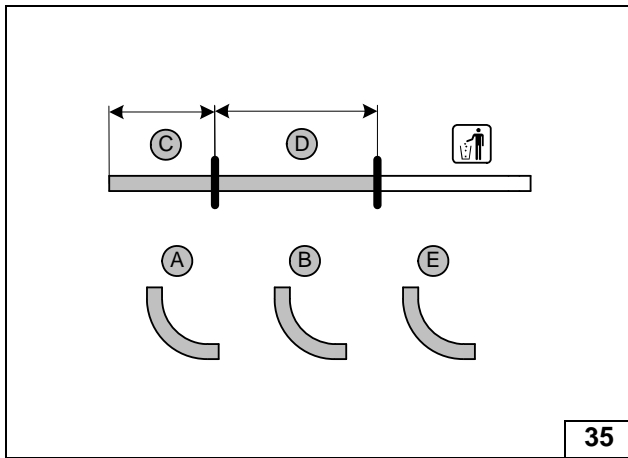

2.0 P

Hoses A, B and E = 90° moulded hose

C = 130
D = 240



Cutting hoses to length

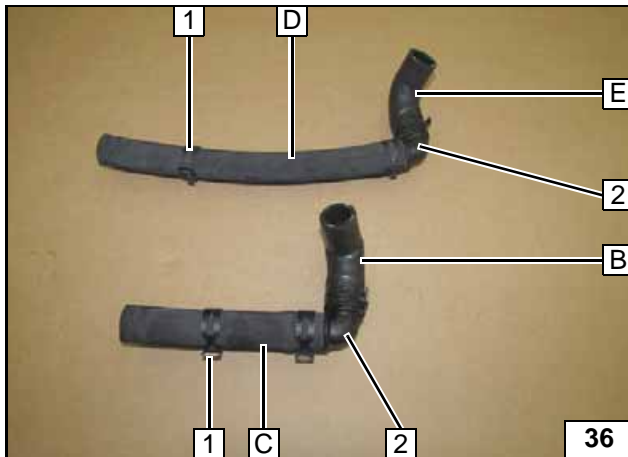

1 Slide on 25mm dia. spring clip [2x]
2 90° 18x18 mm [2x] connecting pipes, 25 mm dia. spring clip [4x]

Premounting hoses

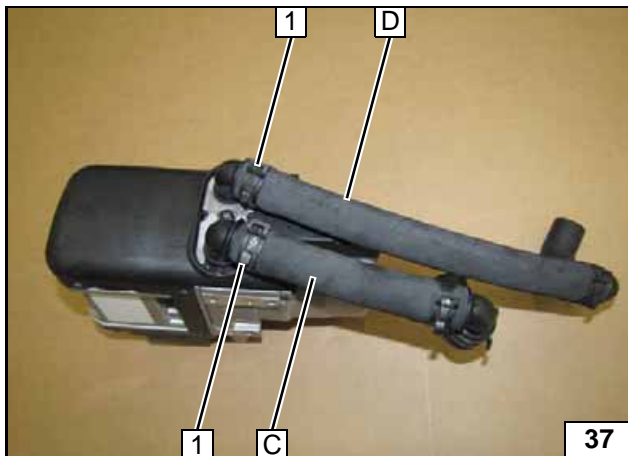

1 25mm dia. spring clip [2x]

Installing hoses

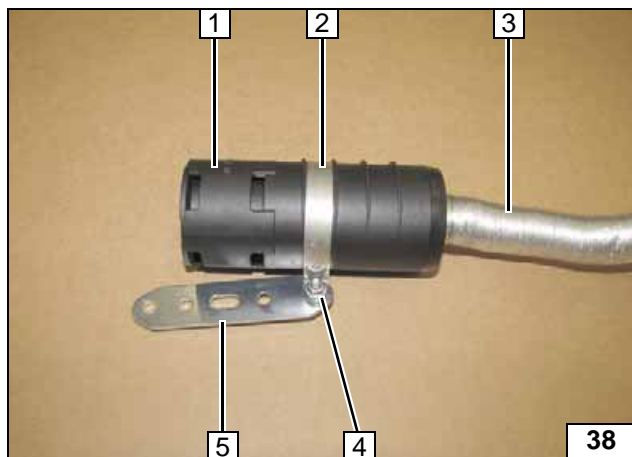
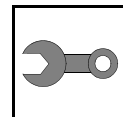

All vehicles

- 1 Combustion air silencer
- 2 51mm dia. clamp
- 3 Combustion air pipe
- 4 M5x13 torx bolt, M5 flanged nut
- 5 Perforated bracket



Premounting combustion air silencer

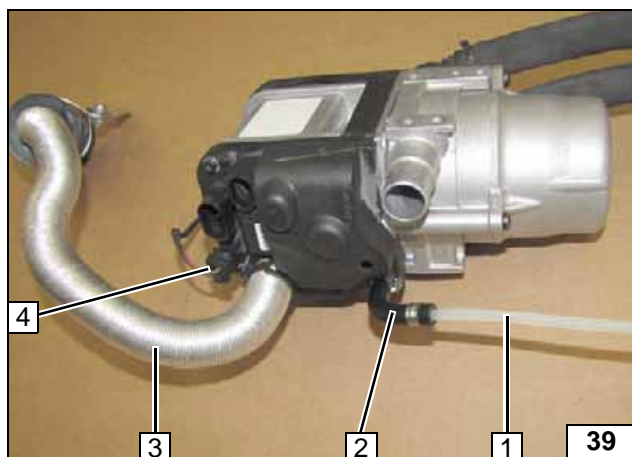

- 1 Fuel line
- 2 90° moulded hose, 10mm dia. clamp [2x]
- 3 Combustion air pipe
- 4 Connector of circulating pump wiring harness

Premounting heater

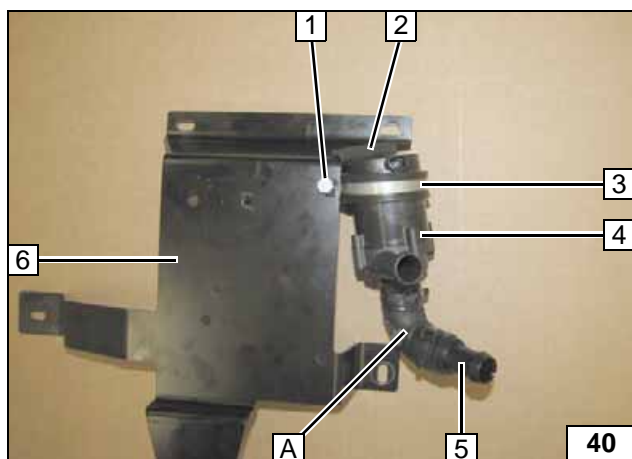

All spring clips = 25 mm dia.!

- 1 M6x20 bolt, flanged nut
- 2 50mm edge protection
- 3 Rubber-coated pipe clamp, 48 mm dia.
- 4 Circulating pump
- 5 18x18 connecting pipe
- 6 Bracket



Premounting bracket

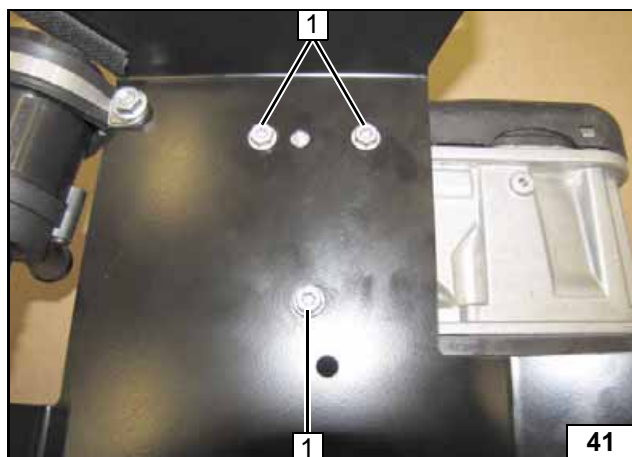

- 1 5x13 self-tapping bolt [3x]

Installing bracket

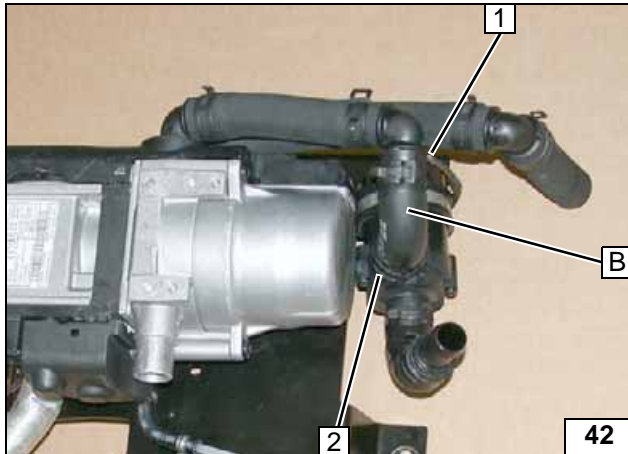
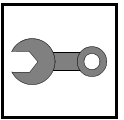

1.6 P

Mount connector of circulating pump wiring harness 1.

2 25mm dia. spring clip

Installing hose B

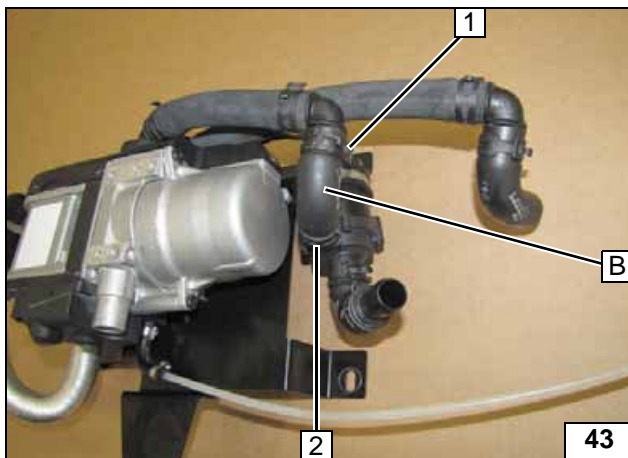

2.0 P

Mount connector of circulating pump wiring harness 1.

2 25mm dia. spring clip

Installing hose B

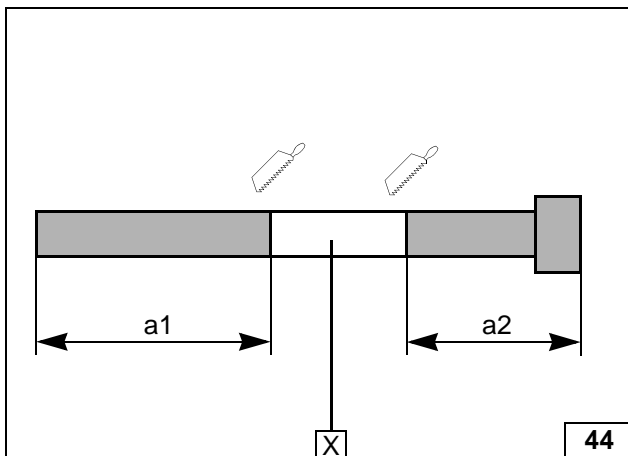

All vehicles

a1 = 620

a2 = 80

X =

Preparing exhaust pipe

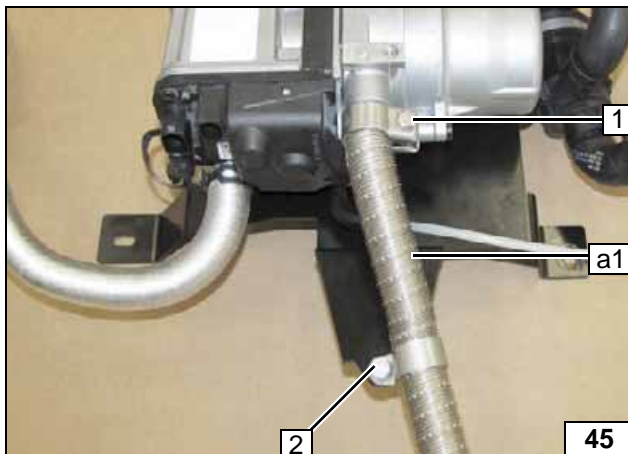

1 Hose clamp

2 M6x20 bolt, pipe clamp, flanged nut

Installing exhaust pipe a1

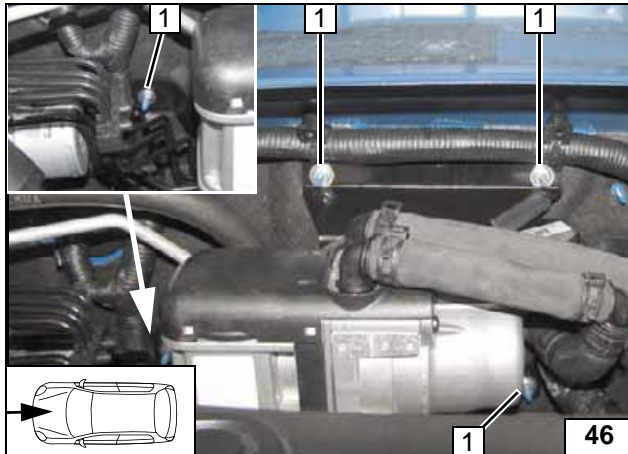
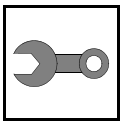

Installing Heater

- 1 Large diameter washer, flanged nut [4x each]

Installing heater

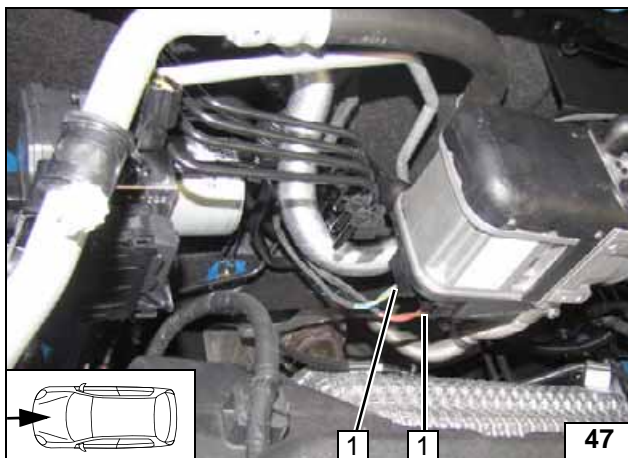

- 1 Heater wiring harness connector [2x]

Install-
ing/routing
wiring har-
ness

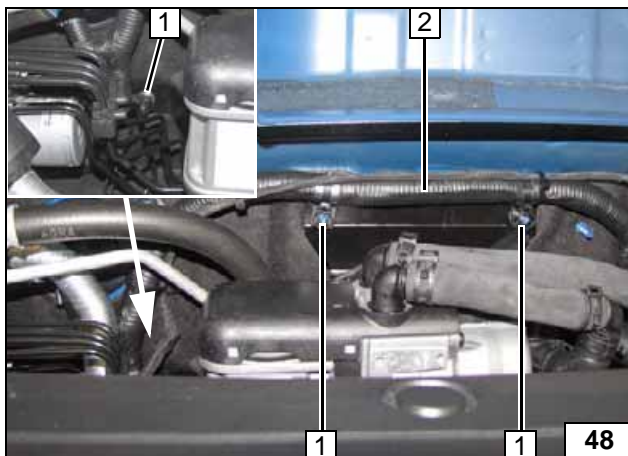

Refasten original vehicle wiring harness on stud bolt 1 [3x].

- 2 Fasten wiring harnesses of inner fuse holder, heater control and heater



Fastening
wiring har-
ness

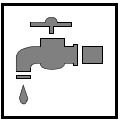

Coolant Circuit 1.6 P





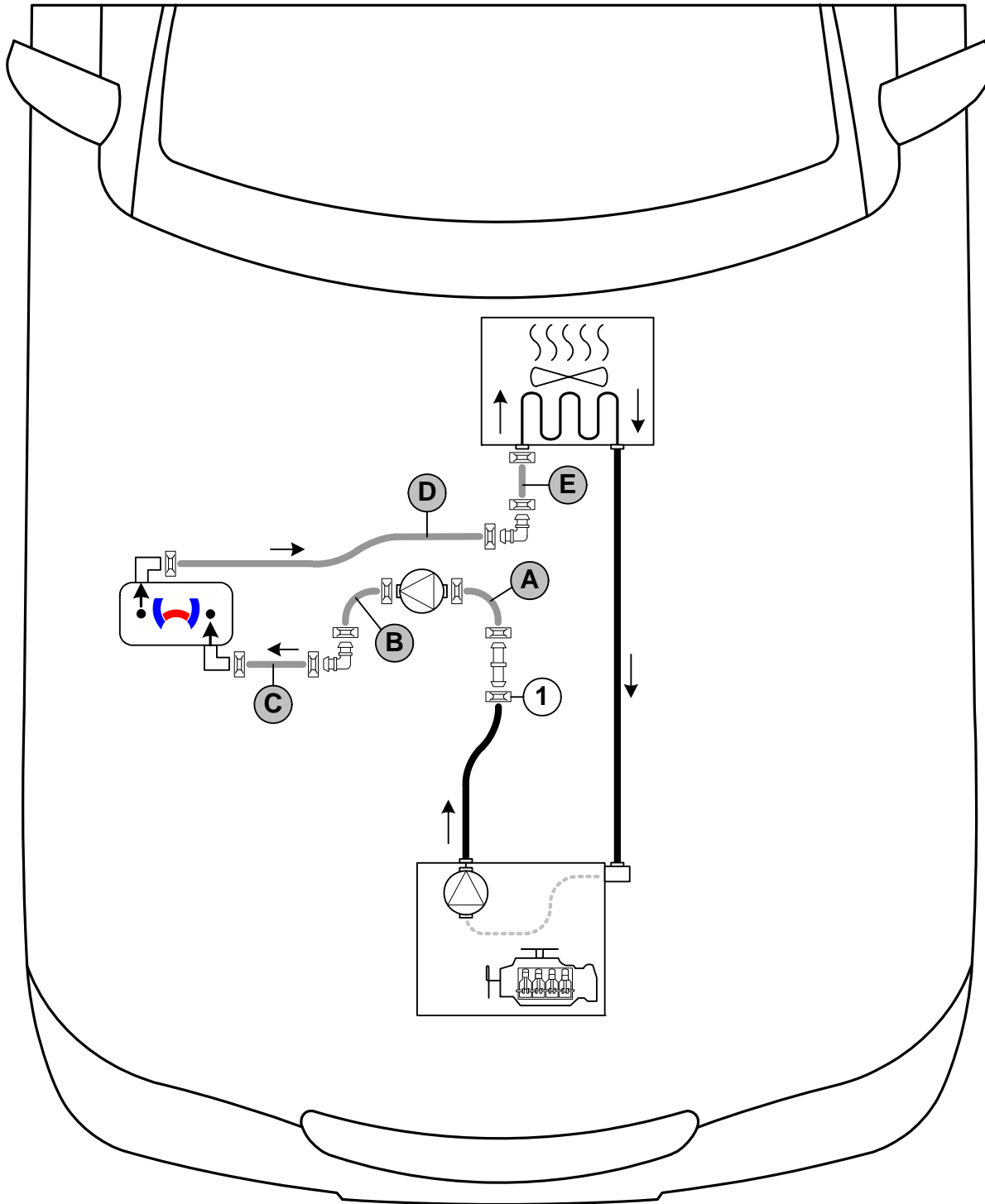

Any coolant running off should be collected in an appropriate container. Route hoses kink-free. Unless specified otherwise, always fasten using cable ties. Position clamps so that other hoses cannot be damaged. The heater must be filled with coolant when installing the hoses.

The connection should be modelled on an 'inline' circuit and based on the following diagram:



Hose routing diagram

All spring clips without a specific designation  = 25 mm dia. All connecting pipes  and  = 18x18mm dia. 1 = Original vehicle spring clip .



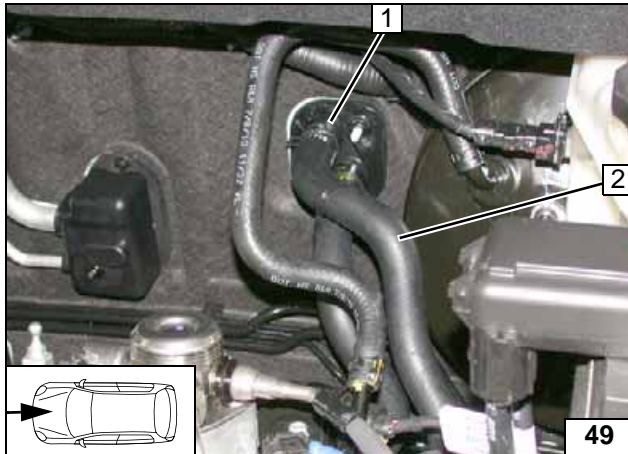

The heater was dismantled for better display. Remove hose of engine outlet 2 on connection piece of heat exchanger inlet. Spring clip 1 will be reused.



Cutting point

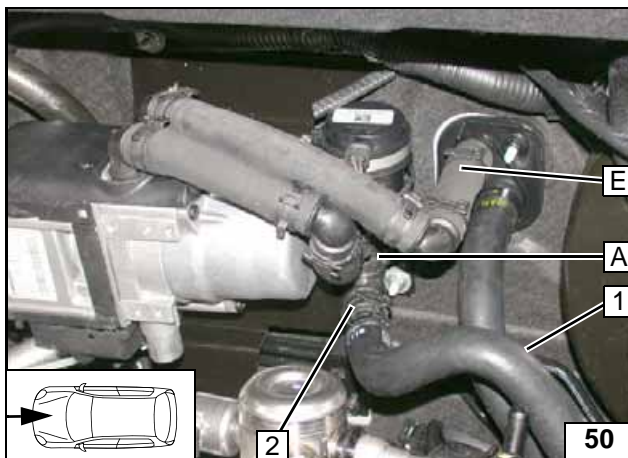

- 1 Hose of engine outlet
- 2 Original vehicle spring clip

**Connect-
ing engine
outlet / heat
exchanger
inlet**

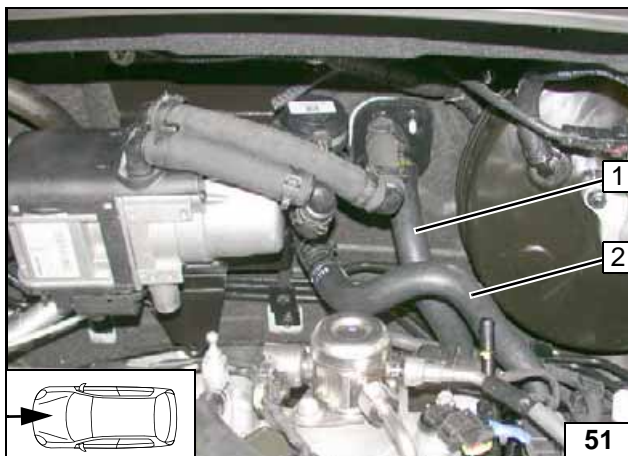

- 1 Hose on heat exchanger outlet
- 2 Hose of engine outlet

Routing

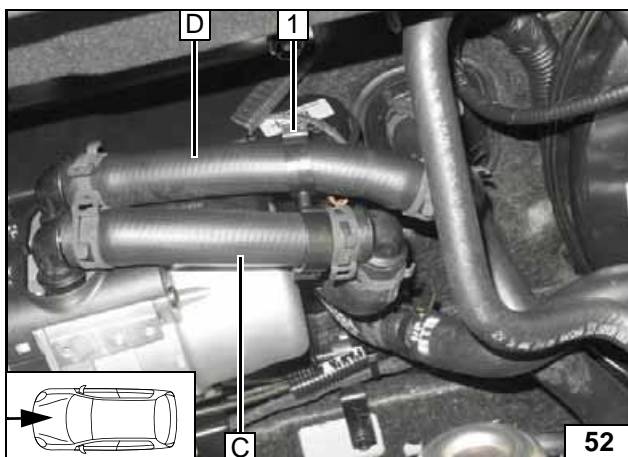

Align hoses. Ensure sufficient distance from neighbouring components, correct if necessary.



- 1 Hose bracket

**Installing
hose brack-
et**

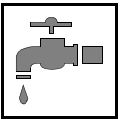

Coolant Circuit 2.0 P





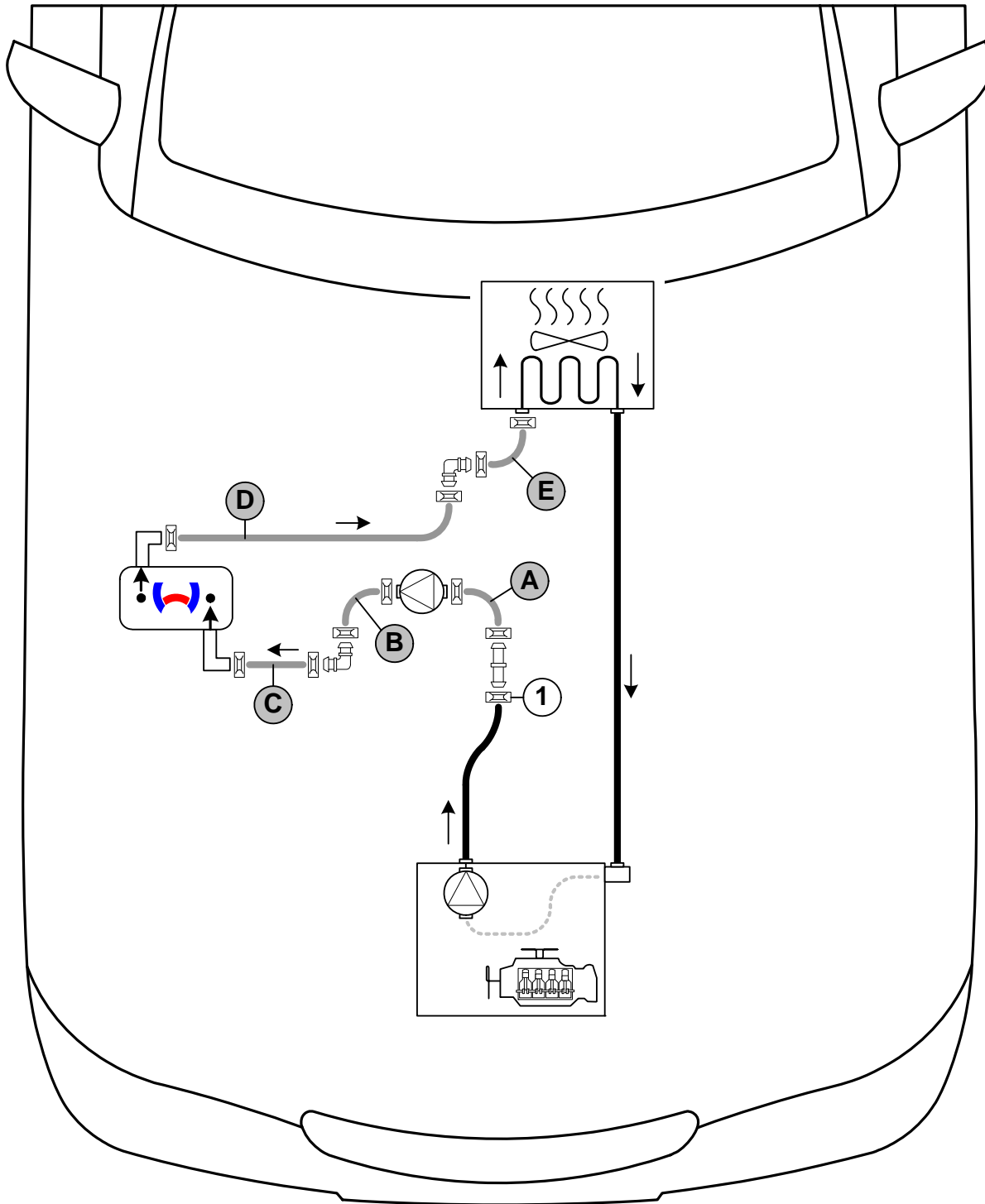

Any coolant running off should be collected in an appropriate container. Route hoses kink-free. Unless specified otherwise, always fasten using cable ties. Position clamps so that other hoses cannot be damaged. The heater must be filled with coolant when installing the hoses.

The connection should be modelled on an 'inline' circuit and based on the following diagram:



Hose routing diagram

All spring clips without a specific designation  = 25 mm dia. All connecting pipes  and  = 18x18mm dia. 1 = Original vehicle spring clip .



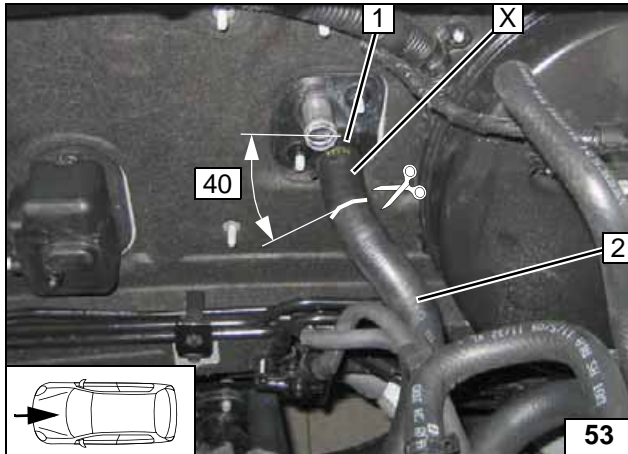
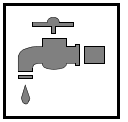

The heater and heat exchanger outlet hose were dismantled for better display. Pull off and shorten hose on connection piece of heat exchanger inlet. Spring clip 1 will be reused.



2 Hose of engine outlet

Cutting point

X =

- 1 Engine outlet hose section
- 2 Original vehicle spring clip

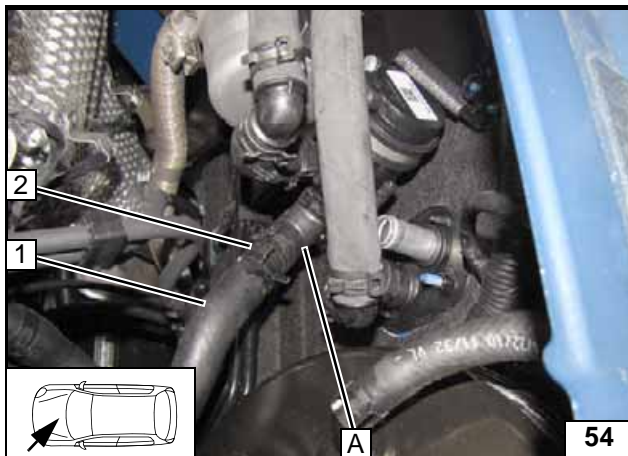

**Connect-
ing engine
outlet**

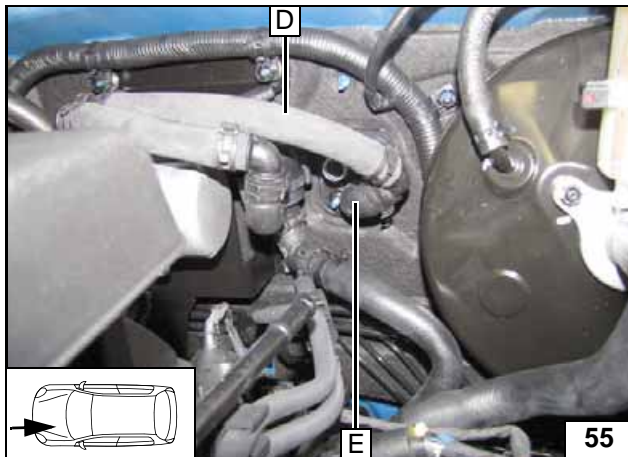

Hose E on heat exchanger inlet.



**Connect-
ing heat ex-
changer
inlet**

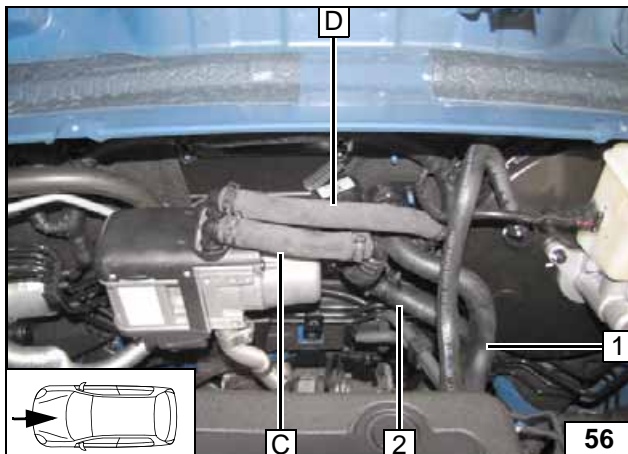

Align hoses. Ensure sufficient distance from neighbouring components.



- 1 Hose section of heat exchanger outlet
- 2 Engine outlet hose section

Routing

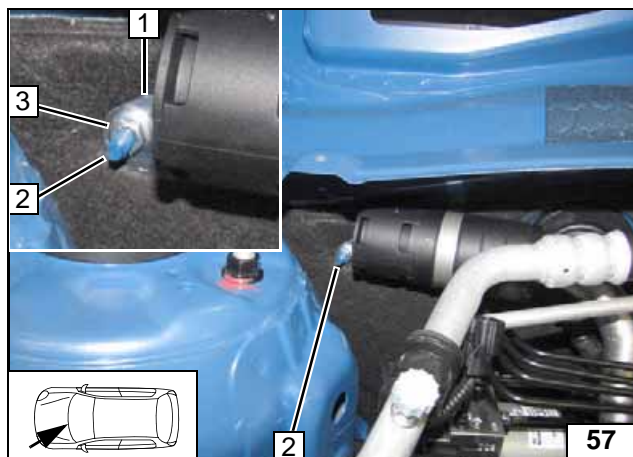
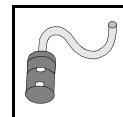

Combustion Air

Remove original vehicle plastic nut at position **3** and discard.

- 1 Perforated bracket
- 2 Original vehicle stud bolt
- 3 M6 flanged nut



Installing silencer

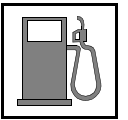

Fuel



Open the vehicle's fuel tank cap, ventilate the tank and then re-close the tank lock.

Catch any fuel running off in an appropriate container.

Route fuel line and metering pump wiring harness so that they are protected against stone impact. Unless specified otherwise, always fasten using cable ties.



Provide rub protection for fuel line and wiring harness in areas where there are sharp edges.

The fuel line and wiring harness are routed to the metering pump as shown in the wiring harness routing diagram.

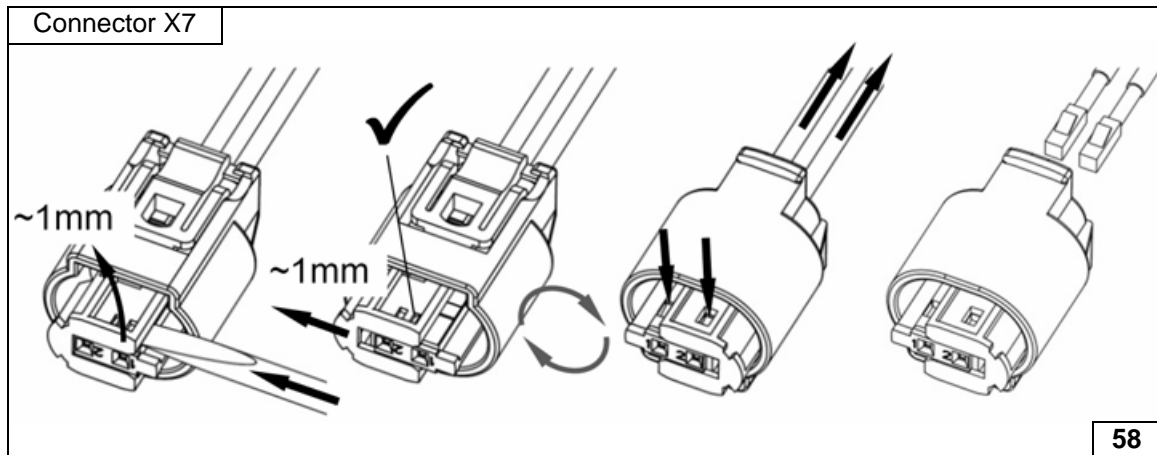

Dismantling metering pump connector

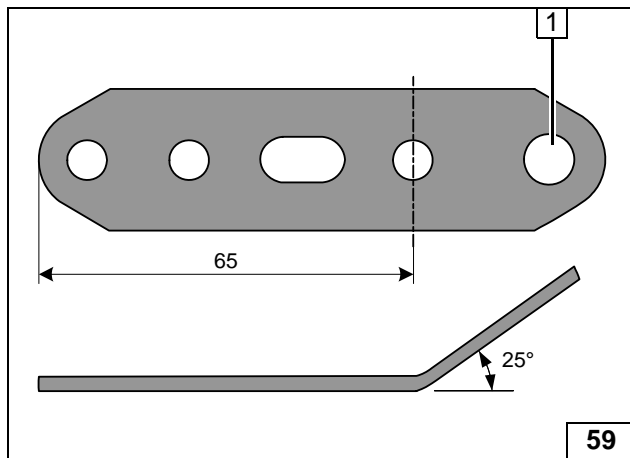

1 Drill hole up to 8.5 mm dia.

Preparing perforated bracket

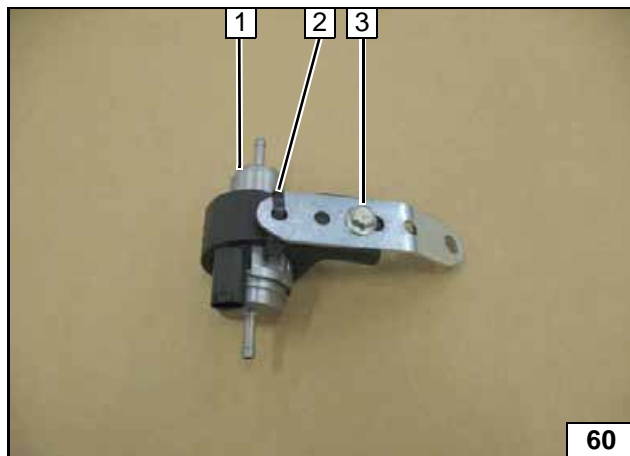

- 1 Metering pump
- 2 Cable tie
- 3 M6x25 bolt, support angle bracket, flanged nut

Premounting metering pump

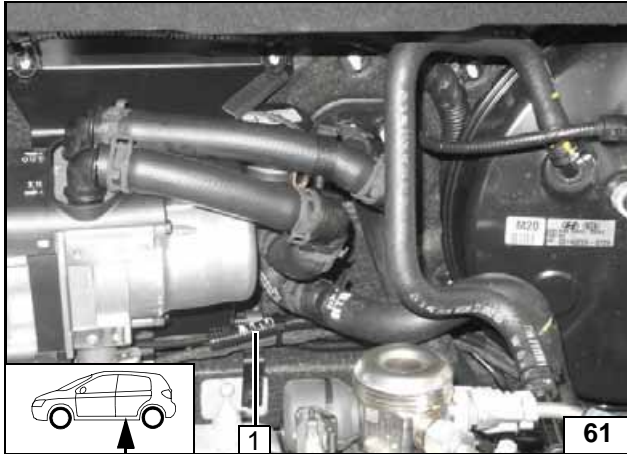
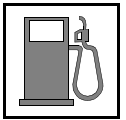

Draw fuel line and wiring harness of metering pump into 2100 mm corrugated tube **1** and route along original vehicle fuel lines to the underbody.



Routing lines

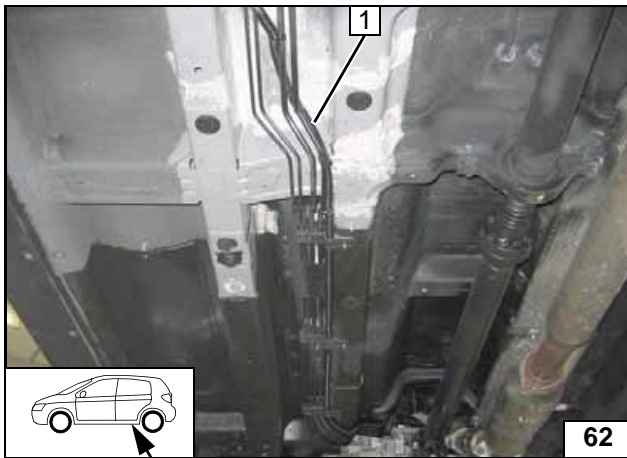

Route fuel line and metering pump wiring harness in corrugated tube **1** on the underbody to installation location of metering pump.



Routing lines

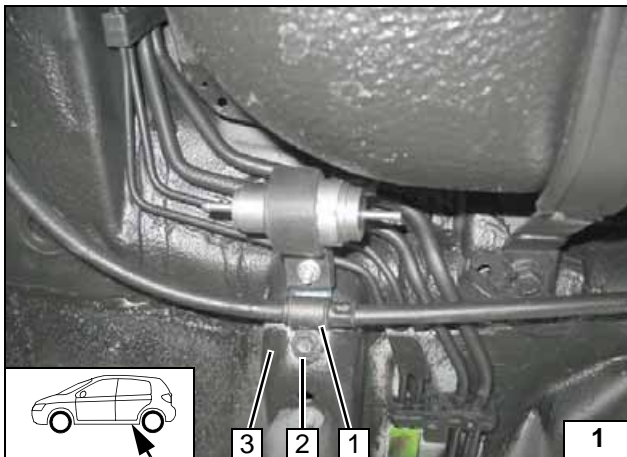

Fasten premounted metering pump between handbrake cable clamp **1** and body **3** with original vehicle bolt **2**.



Installing metering pump

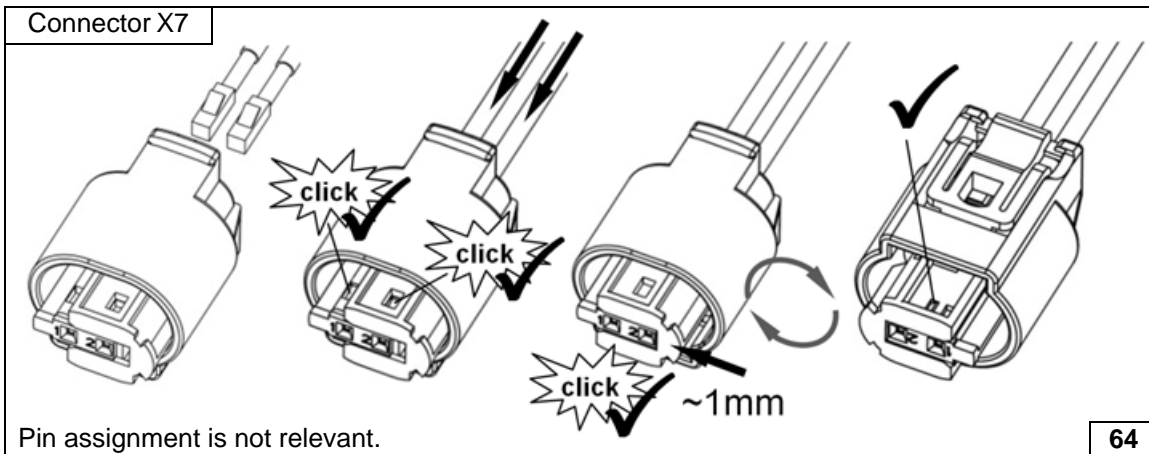

Pin assignment is not relevant.

Completing metering pump connector

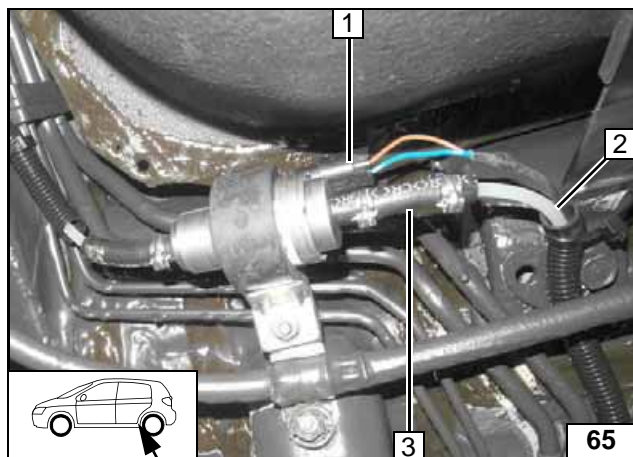

- 1 Metering pump wiring harness, connector X7 mounted
- 2 Fuel line of heater
- 3 Hose section, 10mm dia. clamp [2x]



**Connect-
ing meter-
ing pump**

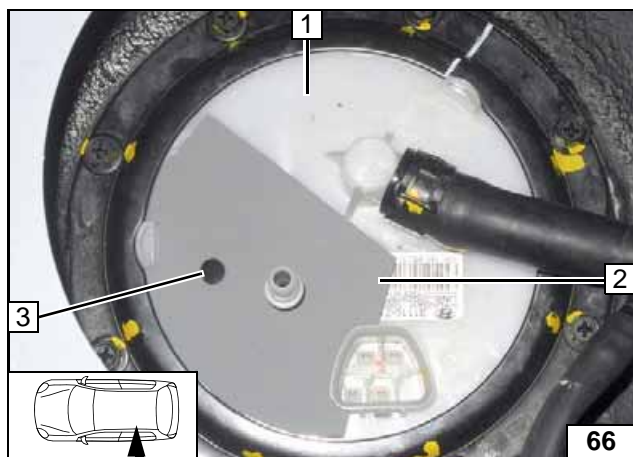

Installing FuelFix

Work steps F1, F2 and F3.

- 1 Fuel tank sending unit
- 2 Position template
- 3 Copy hole pattern, hole made with provided drill



**Copying
hole pattern**

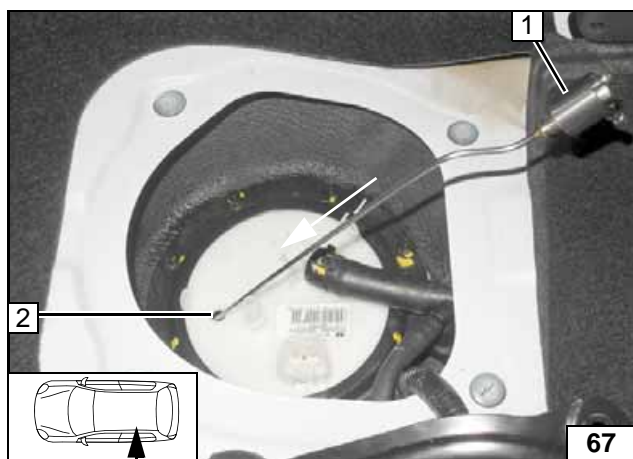

Work steps F4 and F5.

Bend FuelFix 1 according to template and cut to length.
Insert into hole 2.



**Inserting
FuelFix**



Work step F5.

**Inserting
FuelFix**

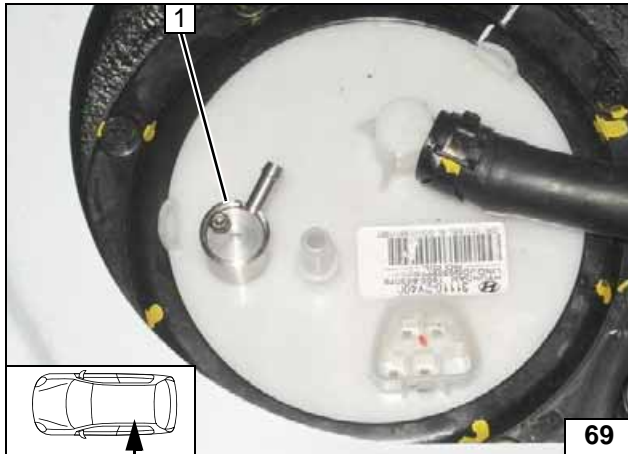
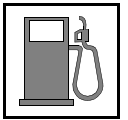

Work steps F5.3 and F5.4.

Align FuelFix 1 as shown.



Aligning FuelFix



Work step F6.

- 1 Hose section, 10mm dia. clamp [2x]
- 2 Fuel line of FuelFix

Connecting fuel line

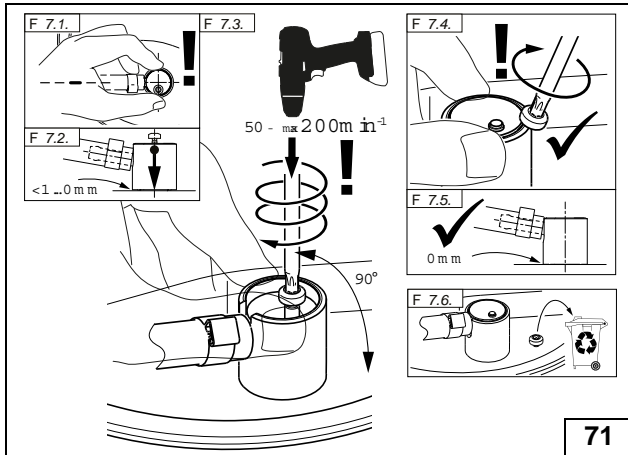

Work step F7.



Installing FuelFix



Work step F8.

Checking firm seating of FuelFix

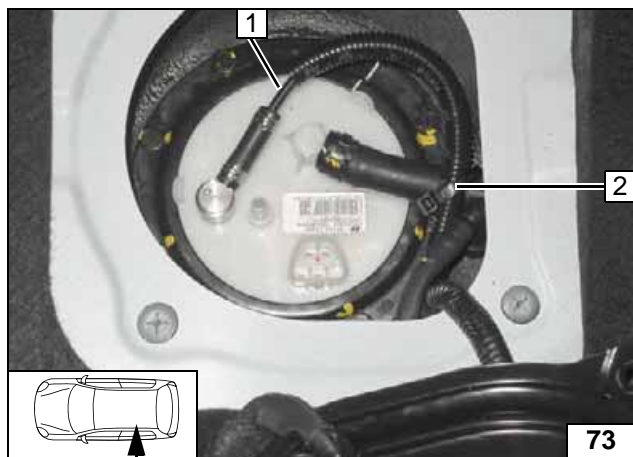

Work step F8.

- 1 Fuel line of FuelFix
- 2 Cable tie as tension relief



Securing fuel line

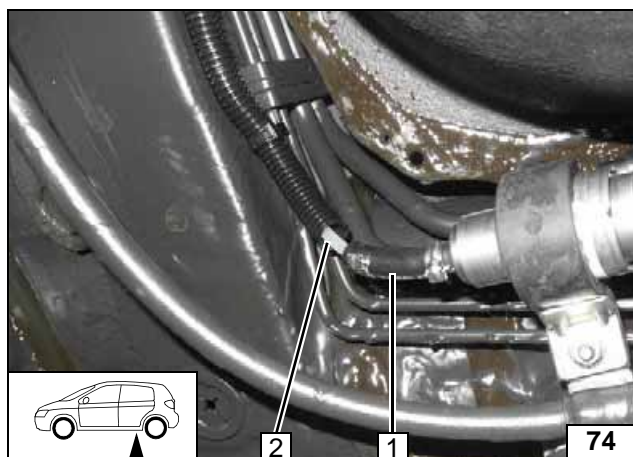

Ensure sufficient distance from neighbouring components, correct if necessary.

- 1 Hose section, 10mm dia. clamp [2x]
- 2 Fuel line



**Connect-
ing meter-
ing pump**

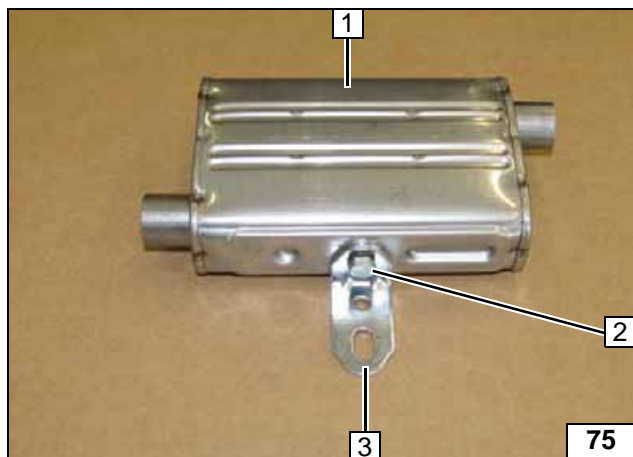
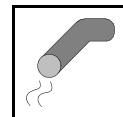

Exhaust Gas

2 WD

- 1 Silencer
- 2 M6x16 bolt, spring lockwasher
- 3 Angle bracket

Premount-
ing silencer

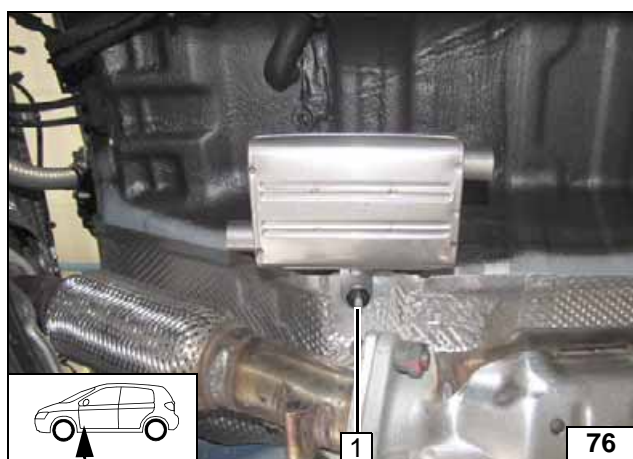

- 1 Original vehicle stud bolt, angle bracket, original vehicle flanged nut

Installing
silencer

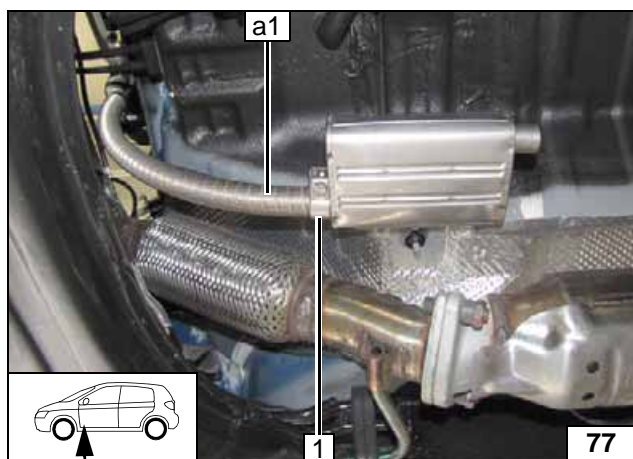

- 1 Hose clamp

Securing
exhaust
pipe a1

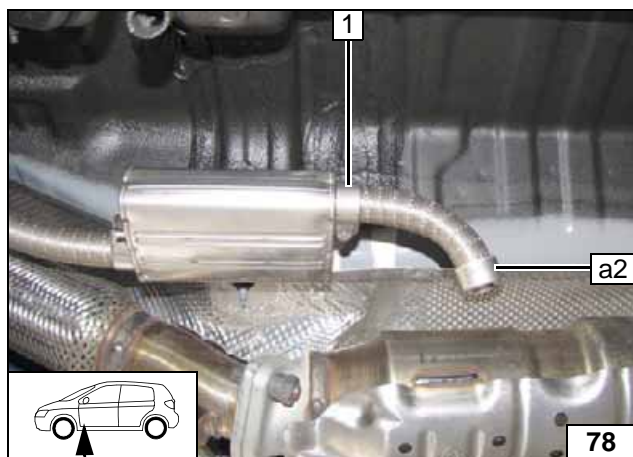

Align exhaust pipe a2.

- 1 Hose clamp

Installing
exhaust
pipe a2



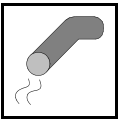

4 WD

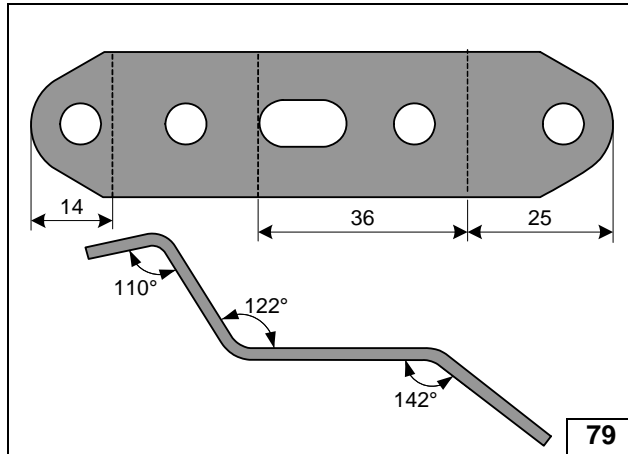

Preparing perforated bracket

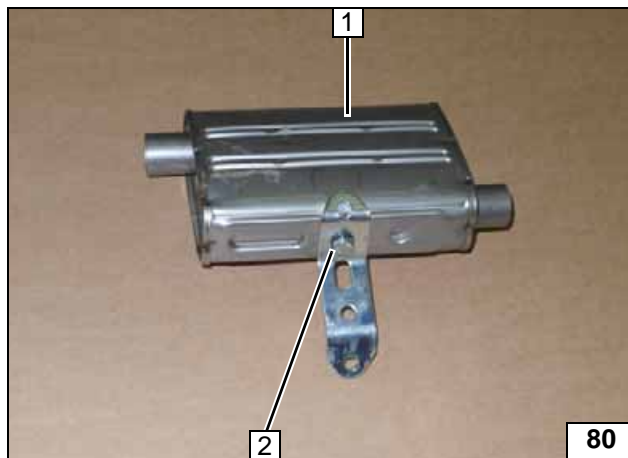

- 1 Silencer
- 2 M6x16 bolt, spring lockwasher

Premounting silencer

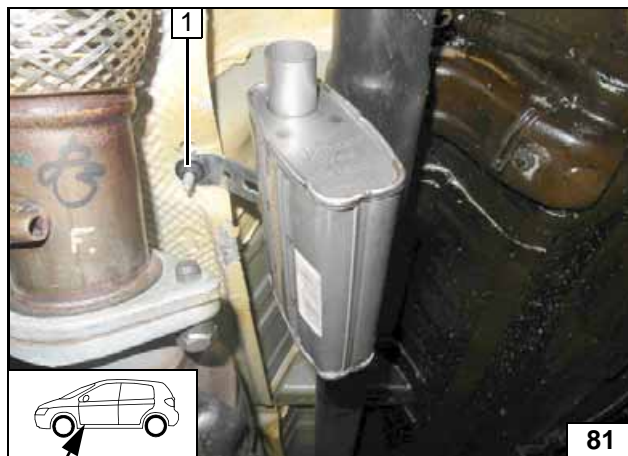

- 1 Original vehicle stud bolt, original vehicle flanged nut

Installing silencer



- 1 Hose clamp

Installing exhaust pipe a1

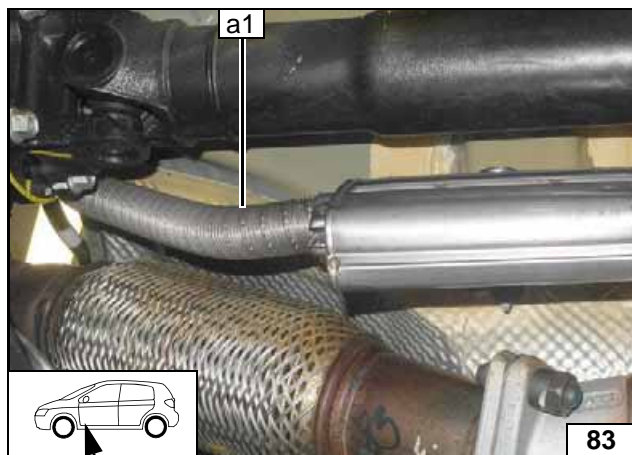
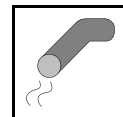

Ensure sufficient distance between exhaust pipe **a1** and exhaust system as well as cardan shaft, correct if necessary.



Aligning exhaust pipe a1

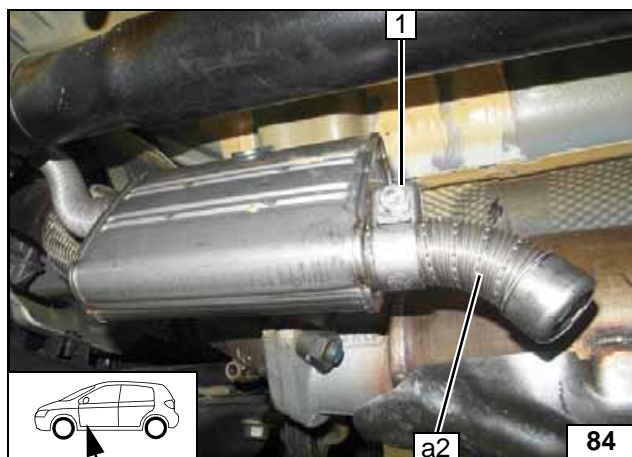

Ensure sufficient distance from neighbouring components, correct if necessary.

1 Hose clamp



Installing exhaust pipe a2

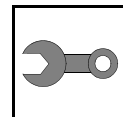

Final Work



Reassemble the components in reverse order. Check all hoses, clamps and all electrical connections for firm seating. Insulate loose wire ends and tie back.
Only use manufacturer-approved coolant. Spray the heater components with anti-corrosion wax (Tectyl 100K).

- **Connect the battery.**
- **Fill and bleed the coolant circuit according to the vehicle manufacturer's specifications.**
- **Program MultiControl CAR, teach Telearstart transmitter.**
- **Make settings on A/C control panel according to the 'Operating Instructions for Automatic Air-Conditioning'.**
- **Place the 'Switch off parking heater before refuelling' caution label near the filler neck.**
- **For initial startup and function check, please see installation instructions.**

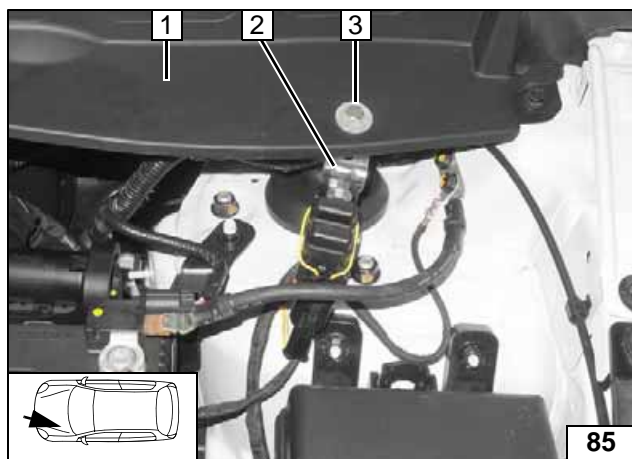

- 1 Mount coolant reservoir with cover
- 2 Angle bracket
- 3 M6x20 bolt, large diameter washer, flanged nut

Installing fuse holder of engine compartment

Webasto Thermo & Comfort SE
Postfach 1410
82199 Gilching
Germany
Internet: www.webasto.com
Technical Extranet:
<http://dealers.webasto.com>



Fuel Tank Sending Unit Template

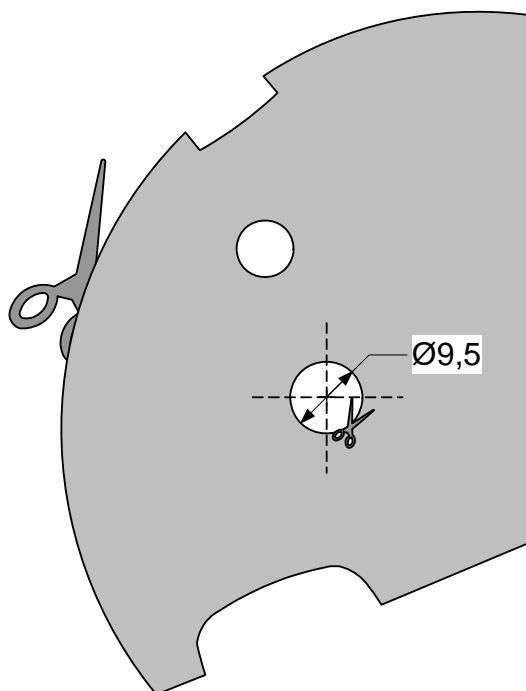

100mm



Scale 1:1

Compare size of printout with dimension lines.
Allowed tolerance a maximum of 2%.

Set the printer settings to 'no margin' or 'minimise margins' and 100% of the normal size.

100mm

0



FuelFix Template

Top view

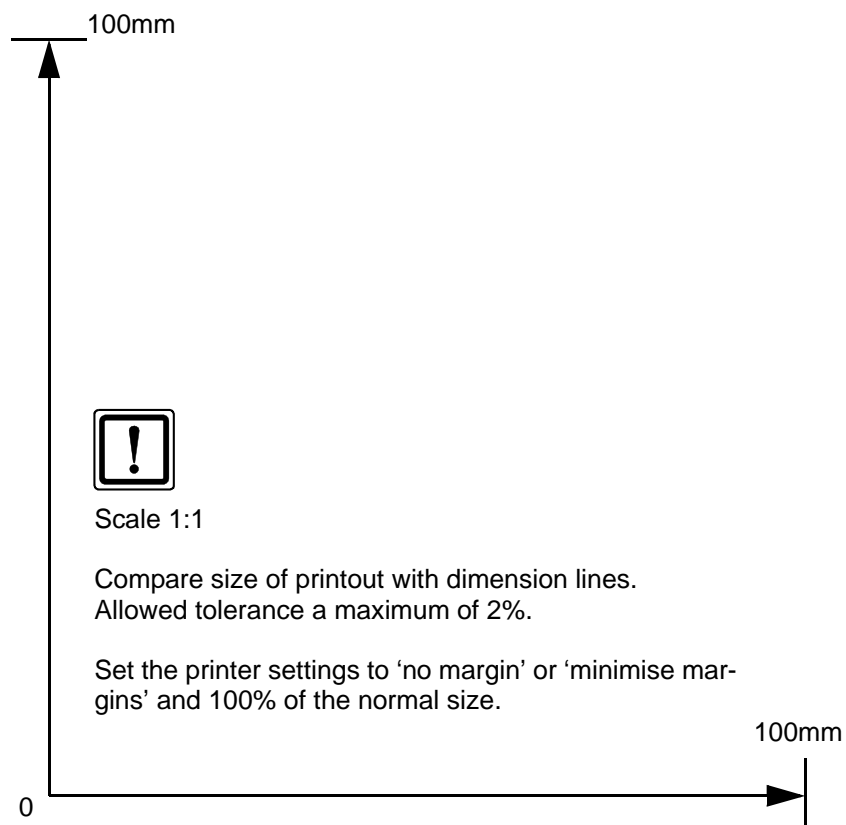
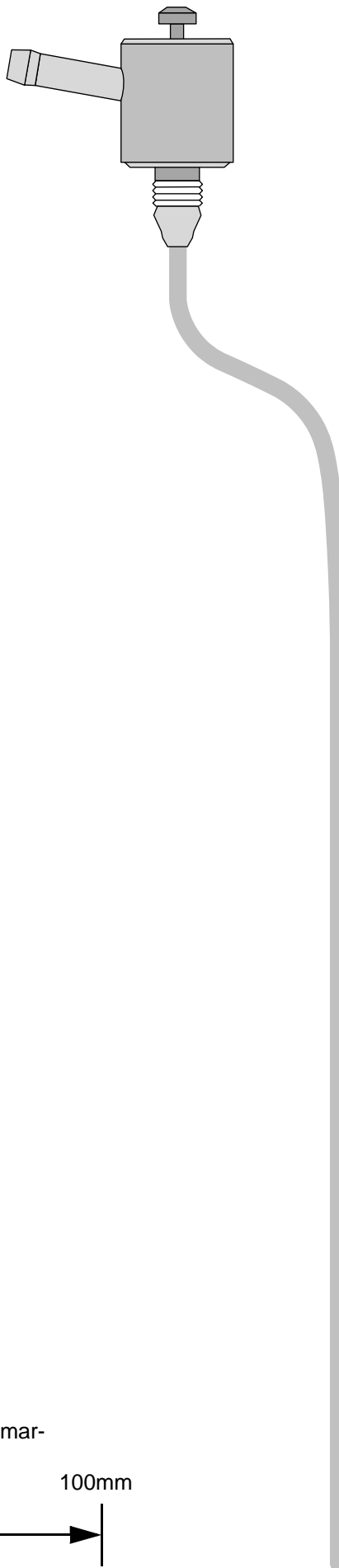
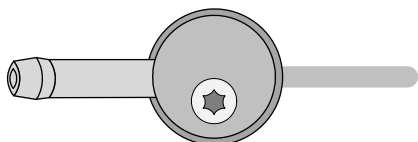

Scale 1:1

Compare size of printout with dimension lines.
Allowed tolerance a maximum of 2%.

Set the printer settings to 'no margin' or 'minimise margins' and 100% of the normal size.

Operating Instructions for Automatic Air-Conditioning

Please remove page and add to the vehicle operating instructions.

Note:

We recommend matching the heating time to the driving time.
 Heating time = driving time

Example:

For a driving time of approx. 20 min. (in one direction), we recommend not exceeding a switch-on time of 20 min.

Passenger compartment monitoring, if installed, must be deactivated in addition to the vehicle settings for the heating operation.

For instructions on deactivation, please refer to the operating instructions of the vehicle.

Before parking the vehicle, make the following settings:



- 1 Air outlet faces 'upward'
- 2 Set temperature on both sides to 'HI'
- 3 Set fan to level '2', or max. '3'

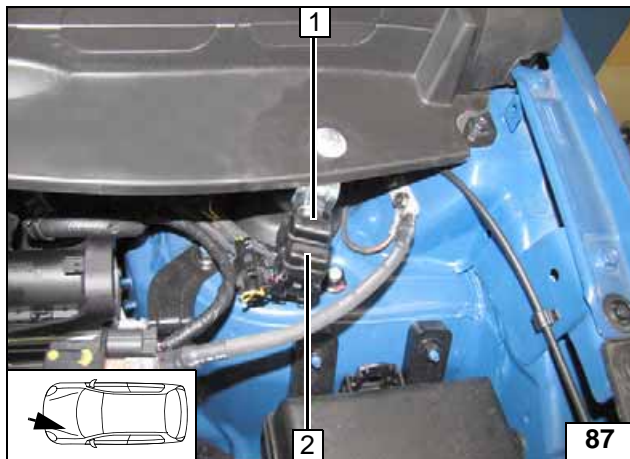

- 1 30A passenger compartment main fuse F2
- 2 20A heater fuse F1

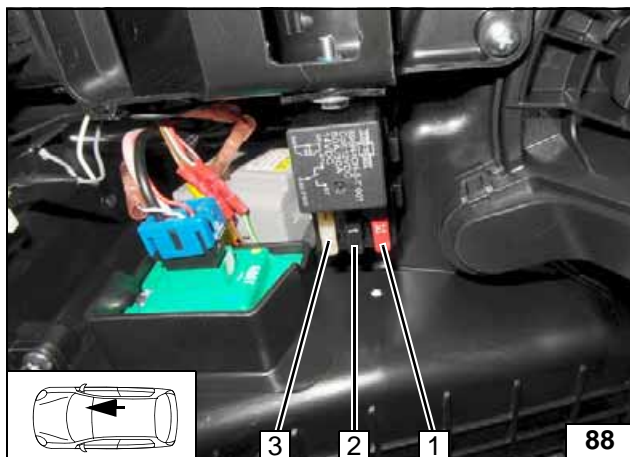

- 1 10A additional fuse F5
- 2 1A heater control fuse F3
- 3 25A fan fuse F4



A/C control panel

Engine compartment fuses

Passenger compartment fuses

