

# Wasser Heater

## Thermo Top Evo Parking Heater



# Installation Documentation

## Mazda 3

### Validity

Manufacturer	Model	Type	EG-BE-No. / ABE	VIN
Mazda	3	BL	e11 * 2001 / 116 *0262 *10...	JMZBM...

Motorisation	Fuel	Transmission type	Output in kW	Displacement in cm <sup>3</sup>	Engine code
2.2 (D150)	Diesel	6-speed MT	110	2191	SH
2.2 (D150)	Diesel	6-speed AT	110	2191	SH

MT = Manual transmission  
 AT = Automatic transmission

**From Model Year 2013**  
**Left-hand drive vehicle**

**Verified equipment variants:**

- Manual air-conditioning (7-speed)
- Automatic air-conditioning (dual type)
- Front fog light
- Xenon with headlight washer system
- i-Stop (Start-Stop)
- Daytime Running Lights in headlight

**Exclusion:**

- Theft Deterrent System. (Intrusion Sensor could trigger the alarm unintentionally)
- Manual air-conditioning (4-speed)

**Total installation time:** about 8 hours

## Mazda 3

### Table of Contents

Validity	1	Preparing Heater	20
Table of Contents	2	Installing Heater	21
Necessary Components	2	Coolant Circuit	23
Installation Overview	2	Fuel	33
Notes on Total Installation Time	2	Combustion Air	38
Information on Operating and Installation Instructions	3	Exhaust Gas	39
Notes on Validity	4	Final Work	41
Technical Instructions	4	Readjustment blower speed	44
Explanatory Notes on Document	4	Operating Instructions for manual A/C (7-speed)	46
Preliminary Work	5	Operating Instructions for auto A/C (Dual type)	48
Heater Installation Location	6		
Preparing Electrical System	7		
Electrical System	15		
Blower Fan Control	16		
Digital Timer	18		
Remote Control Option (Telestart)	18		
Thermo Call Option	19		

### Necessary Components

- Basic delivery scope *Thermo Top Evo* in accordance with price list
- Installation kit for Mazda 3 from 2013 Diesel: Mazda Order No.: **4100-78-715B**
- Heater control in accordance with price list and upon consultation with end customer
- In case of Telestart, indicator lamp in accordance with price list and in consultation with end customer

### Installation instructions:

- Have the vehicle delivered with the tank only about one quarter full!
- The installation location of the push button in the case of Telestart or Thermo Call should be confirmed with the end customer.

### Installation Overview

#### Legend:

1. Heater
2. Fuse holder of engine compartment
3. Relay and fuse holder of passenger compartment
4. PWM GW
5. Circulating pump
6. Digital timer option
7. Receiver Remote and/or Thermo call option
8. Metering pump

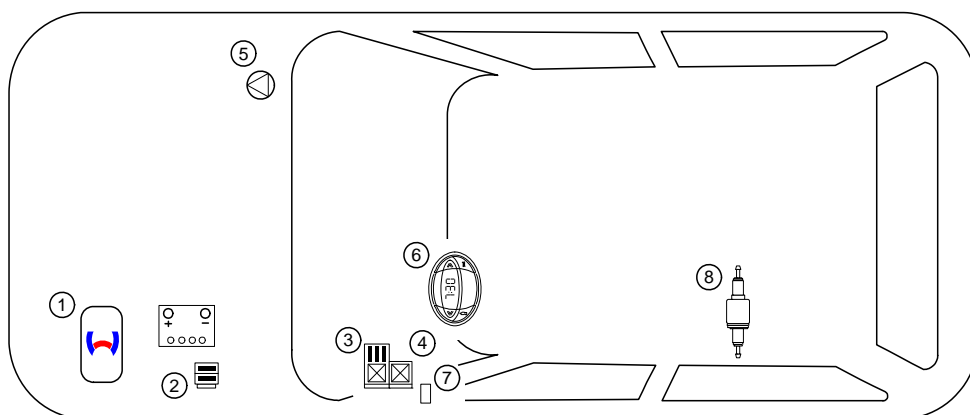

### Notes on Total Installation Time

The total installation time includes the time needed for mounting and demounting of the vehicle-specific components, the heater specific installation time and all other times required for the system integration and initial start-up of the heater.

The total installation time may vary for vehicle equipment other than provided.

## Information on Operating and Installation Instructions

### 1 Important Information (not complete)

#### 1.1 Installation and Repair



The improper installation or repair of Webasto heating and cooling systems can cause fire or the leakage of deadly carbon monoxide, leading to serious injury or death.



To install and repair Webasto heating and cooling systems you need to have completed a special company training course and have the appropriate technical documentation, special tools and special equipment.



Installation and repair may ONLY be carried out by persons trained and certified in a Webasto training course. NEVER try to install or repair Webasto heating or cooling systems if you have not completed a Webasto training course, you do not have the necessary technical skills and you do not have the technical documentation, tools and equipment available to ensure that you can complete the installation and repair work properly.

Only use genuine Webasto parts. See the Webasto air and water heaters accessories catalogue for this purpose.

#### 1.2 Operation

To ensure safe operation, we recommend having the heater checked every two years by an authorised Webasto dealer, especially when used over a long period and/or under extreme environmental conditions.

Do not operate the heater in closed rooms due to the danger of poisoning and suffocation.

Always switch off the heater before refuelling.

The heater may only be used with the prescribed fuel Diesel (DIN EN 590) or petrol (DIN EN 228).

The heater may not be cleaned with a high-pressure cleaner.

#### 1.3 Please note

ALWAYS follow all Webasto installation and operating instructions and observe all warnings.

To become familiar with and understand all functions and properties of the heater, the operating instructions must be read carefully and observed at all times.

For proper, safe installation and repair work, the installation instructions with all warnings and safety information must be carefully read and observed at all times. Please always contact a workshop authorised by Webasto for all installation and repair work.

#### Important

**Webasto shall assume no liability for defects, damage and injuries resulting from a failure to observe the installation, repair and operating instructions of the information contained in them.**

**This liability exclusion particularly applies to improper installations and repairs, installations and repairs by untrained persons or in the case of a failure to use genuine spare parts.**

**The liability due to culpable disregard to life, limb or health and due to damage or injuries caused by a wilful or reckless breach of duty remain unaffected, as does the obligatory product liability.**

**Installation should be carried out according to the general, standard rules of technology. Unless specified otherwise, fasten hoses, lines and wiring harnesses to original vehicle lines and wiring harnesses using cable ties. Insulate loose wire ends and tie back. Connectors on electronic components must audibly snap into place during assembly.**

**Sharp edges should be fitted with rub protection. Spray unfinished body areas, e.g. drilled holes, with anti-corrosion wax (Tectyl 100K).**

**Observe the instructions and guidelines of the respective vehicle manufacturer for demounting and mounting vehicle specific components!**

**The initial startup is to be executed with the Webasto Thermo Test Diagnosis.**

**When installing a programmable control module (e.g. a PWM Gateway), the corresponding settings must be checked or adjusted.**

### 2 Statutory regulations governing installation

Guidelines	Thermo Top Evo
Heating Directive ECE R122	E1 00 0258
EMC Directive ECE R10	E1 04 5627

#### Note

The regulations of these guidelines are binding in the scope of the Directive 70/156/EEC and/or 2007/46/EC (for new vehicle models from 29/04/2009) and should also be observed in countries in which there are no special regulations.

#### Important

Failure to follow the installation instructions will result in the invalidation of the type approval for the heater and therefore invalidation of the general **homologation of the vehicle**.

#### Note

The heater is licensed in accordance with paragraph 19, section 3, No. 2b of the StVZO (German Road Traffic Licensing Authority).

### 2.1 Excerpt from the directive ECE-R 122 point 5 (part I) for the installation of the heater

Beginning of excerpt.

#### ANNEX VII

#### REQUIREMENTS FOR COMBUSTION HEATERS AND THEIR INSTALLATION

##### 1. GENERAL REQUIREMENTS

1.7.1. A clearly visible tell-tale in the operator's field of view shall inform when the combustion heater is switched on or off.

##### 2. VEHICLE INSTALLATION REQUIREMENTS

###### 2.1. Scope

2.1.1. Subject to paragraph 2.1.2. combustion heaters shall be installed according to the requirements of this Annex.

2.1.2. Vehicles of category O having liquid fuel heaters are deemed to comply with the requirements of this Annex.

###### 2.2. Positioning of heater

2.2.1. Body sections and any other components in the vicinity of the heater must be protected from excessive heat and the possibility of fuel or oil contamination.

2.2.2. The combustion heater shall not constitute a risk of fire, even in the case of overheating. This requirement shall be deemed to be fulfilled if the installation ensures an adequate distance to all parts and suitable ventilation, by the use of fire resistant materials or by the use of heat shields.

2.2.3. In the case of M2 and M3 vehicles, the heater must not be positioned in the passenger compartment. However, an installation in an effectively sealed envelope which also complies with the conditions in paragraph 2.2.2 may be used.

2.2.4. The label referred to in paragraph 1.4 or a duplicate, must be positioned so that it can be easily read when the heater is installed in the vehicle.

2.2.5. Every reasonable precaution should be taken in positioning the heater to minimise the risk of injury and damage to personal property.

###### 2.3. Fuel supply

2.3.1. The fuel filler must not be situated in the passenger compartment and must be provided with an effective cap to prevent fuel spillage.

2.3.2. In the case of liquid fuel heaters, where a supply separate to that of the vehicle is provided, the type of fuel and its filler point must be clearly labelled.

2.3.3. A notice, indicating that the heater must be shut down before refuelling, must be affixed to the fuelling point. In addition a suitable instruction must be included in the manufacturer's operating manual.

###### 2.4. Exhaust system

2.4.1. The exhaust outlet must be located so as to prevent emissions from entering the vehicle through ventilators, heated air inlets or opening windows.

###### 2.5. Combustion air inlet

2.5.1. The air for the combustion chamber of the heater must not be drawn from the passenger compartment of the vehicle.

2.5.2. The air inlet must be so positioned or guarded that blocking by rubbish or luggage is unlikely.

###### 2.6. Heating air inlet

2.6.1. The heating air supply may be fresh or recirculated air and must be drawn from a clean area not likely to be contaminated by exhaust fumes emitted either by the propulsion engine, the combustion heater or any other vehicle source.

2.6.2. The inlet duct must be protected by mesh or other suitable means.

###### 2.7. Heating air outlet

2.7.1. Any ducting used to route the hot air through the vehicle must be so positioned or protected that no injury or damage could be caused if it were to be touched.

2.7.2. The air outlet must be so positioned or guarded that blocking by rubbish or luggage is unlikely.

End of excerpt.

In multilingual versions the German language is binding.

# Mazda 3

## Notes on Validity

This installation documentation applies to Mazda 3 BM Diesel vehicles - for validity, see page 1 - from model year 2013 and later, assuming technical modifications to the vehicle do not affect installation, any liability claims excluded. Depending on the vehicle version and equipment, modifications may be necessary during installation with respect to this installation documentation.

Vehicle and engine types, equipment variants and other specifications not listed in this installation documentation have not been tested. However, installation according to this installation documentation may be possible.

## Technical Instructions

### Special Tools

- Hose clamp pliers for auto-tightening hose clamps
- Hose clamp pliers for Clic hose clamps of type W
- Automatic wire stripper 0.2 - 6mm<sup>2</sup>
- Crimping pliers for cable lug / tab connector 0.5 - 6mm<sup>2</sup>
- Torque wrench for 2.0 - 20 Nm
- Hose clamping pliers
- Metric thread-setter kit
- Deep hole marker
- Webasto Thermo Test Diagnosis with current software

### Dimensions

- All dimensions are in mm.

## Explanatory Notes on Document

You will find an identification mark on the outside top right corner of the page in question to provide you with a quick overview of the individual working steps.

Special features are highlighted using the following symbols:

### Mechanical system



Specific risk of injury or fatal accidents.



### Electrical system



Specific risk of damage to components.



### Coolant circuit



Specific risk of fire and explosion



### Combustion air

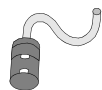

Reference to general installation instructions of the Webasto components or to the manufacturer's vehicle-specific documents (MESI).



### Fuel

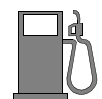

Reference to a specific technical feature



### Exhaust gas



The arrow in the vehicle icon indicates the position on the vehicle and the viewing angle.

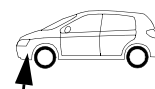

### Software

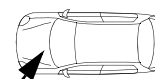

# Mazda 3

## Preliminary Work

### Prior to installation of heater:

**Incorrect implementation of electrical connections can cause a fire!**



#### Warning:

On the Mazda 3, a special battery is used for the i-Stop System (STOP&START). You must check the battery **before** installing the heater. Check battery condition in accordance with workshop manual refer to MESI "BATTERY INSPECTION" (acid density check in every battery cell). If the acid density is below specification, replace the battery with an original battery.

## Vehicle

- Disconnect the battery and remove them completely with the carrier. Refer to MESI "BATTERY REMOVAL/INSTALLATION"
- Remove upper engine cover. Refer to MESI "ENGINE COVER REMOVAL/INSTALLATION"
- Open fuel tank cap
- Ventilate the fuel tank
- Close the fuel tank cap again
- Depressure the cooling system and drain engine coolant. Refer to MESI "Engine Coolant Replacement"
- Remove air cleaner housing. Refer to MESI "INTAKE-AIR SYSTEM REMOVAL/INSTALLATION"
- Remove the front Under Cover. Refer to MESI "Front Under Cover No.2 REMOVAL/INSTALLATION"
- Remove the front right Splash shield No.1. Refer to MESI "SPLASH SHIELD REMOVAL/INSTALLATION"
- Remove the front bumper. Refer to MESI "FRONT BUMPER REMOVAL/INSTALLATION"
- Remove the floor under cover No.1 and 2. Refer to MESI "FLOOR UNDER COVER REMOVAL/INSTALLATION"
- Remove rear lower seat cushion. Refer to MESI "REAR SEAT CUSHION REMOVAL/INSTALLATION"
- Remove the fuel tank service hole cover. Refer to MESI "FUEL TANK REMOVAL/INSTALLATION"
- Remove the front scuff plate on the driver's side. Refer to MESI "FRONT SCUFF PLATE REMOVAL/INSTALLATION"
- Remove the lower front left side trim. Refer to MESI "FRONT SIDE TRIM REMOVAL/INSTALLATION"
- Remove the lower panel on driver side. Refer to MESI "LOWER PANEL REMOVAL/INSTALLATION"
- Remove the loudspeaker cover on the left, upper instrument panel trim (only for Telestart and/or Thermo Call). Refer to MESI "SPEAKER GRILLE REMOVAL/INSTALLATION"
- Loosen and pull off carefully the left side of the driver-side lower panel. Refer to MESI "CLUSTERSWITCH REMOVAL/INSTALLATION"
- Remove the glove compartment. Refer to MESI "GLOVE COMPARTMENT REMOVAL/INSTALLATION"

## Heater



Remove years that do not apply from the type and duplicate label.  
Attach the duplicate label 1 on B-pillar.



<b>Webasto</b>	
Thermo & Comfort SE	
Made in Germany	CE
Model Type	E1
Operating Voltage	
Rated Output	
Fuel Type	
Working Pressure	
Part No. 444444	Serial No. X123456789
Year of Manufacture	

**Attach duplicate label**

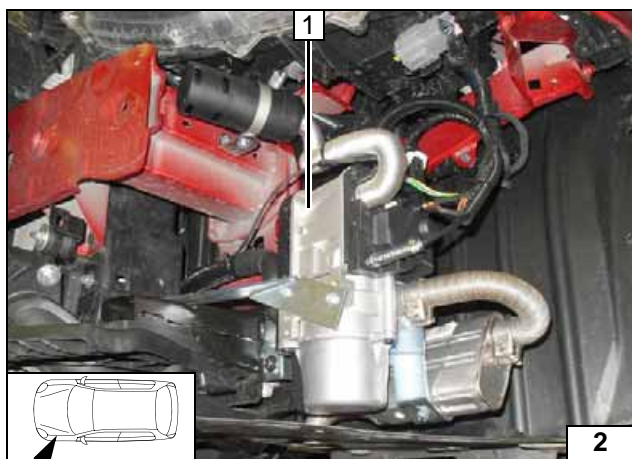

### Heater Installation Location

1 Heater

Installation location

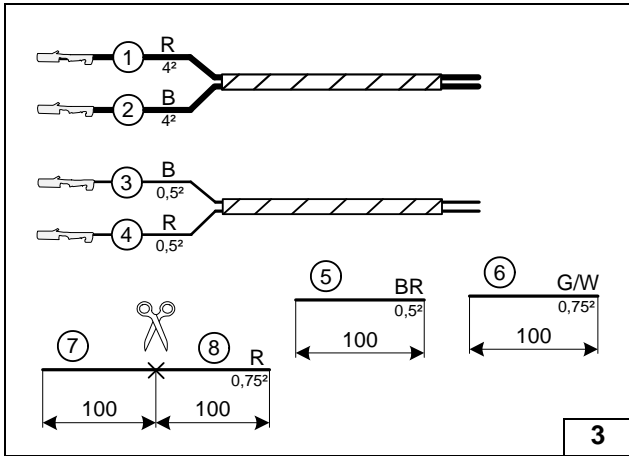
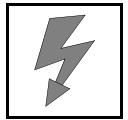

### Preparing Electrical System

Wire sections retain their numbering through the entire document.

Produce all following electrical connections as shown in the wiring diagram.

- ① Ltg. R blower wiring harness
- ② Ltg. B blower wiring harness
- ③ Ltg. B wiring harness PWM GW control
- ④ Ltg. R wiring harness PWM GW control

**Cutting to length/  
assigning wires**

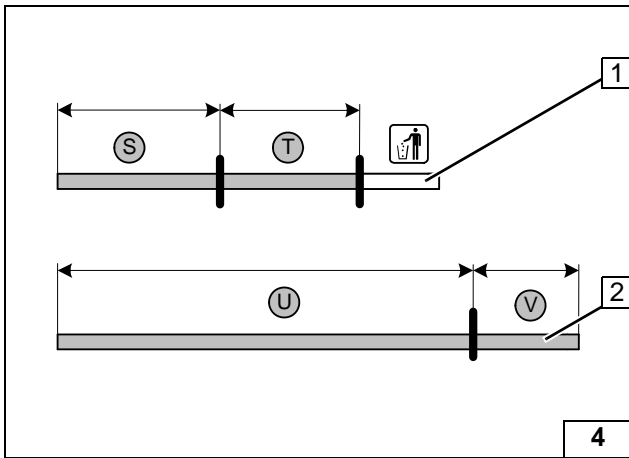

- 1 Corrugated tube Ø 10, length 1130

S = 400  
T = 350

- 2 Corrugated tube Ø 10, length 2100

U = 1850  
V = 250

**Cutting  
Corrugate  
tube and  
Protective  
sleeving  
to length**

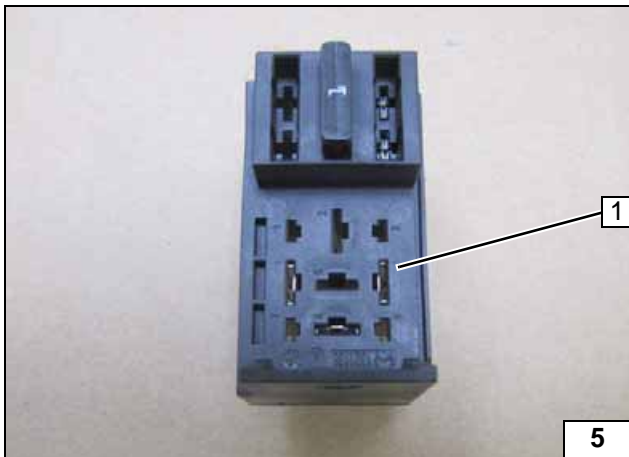

### Version 1

- 1 9-pole relay socket

**View relay and  
fuse holder  
(passenger  
compartment)  
Version 1**

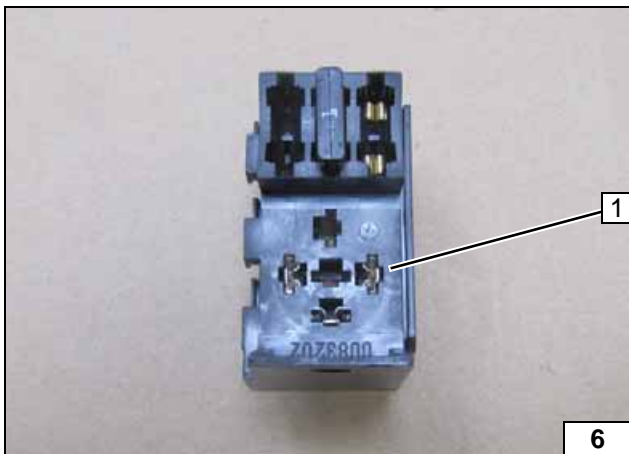

### Version 2

- 1 5-pole relay socket

**View relay and  
fuse holder  
(passenger  
compartment)  
Version 2**



Version 1 (9-pole relay socket)

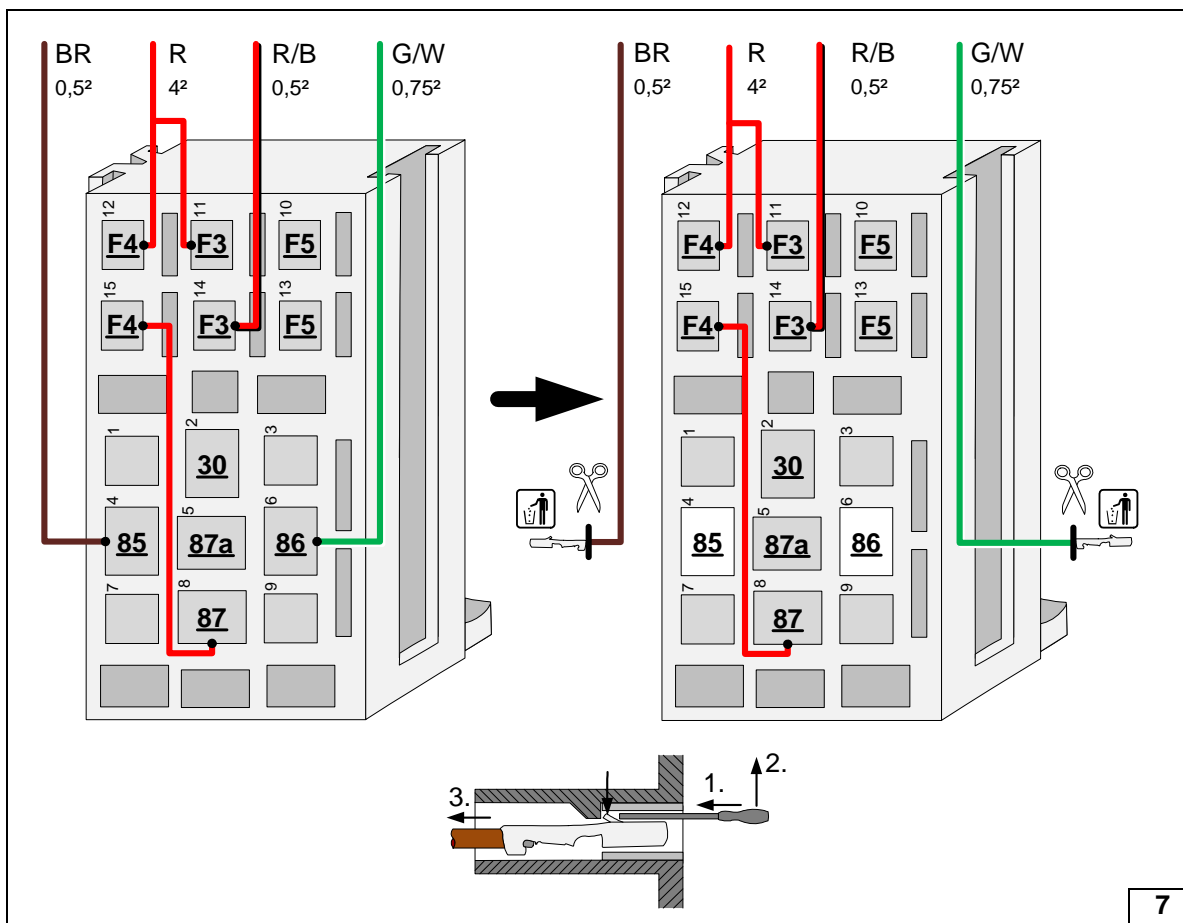

Detach contacts  
Relay and fuse  
holder in  
passenger  
compartment /  
Version 1

7

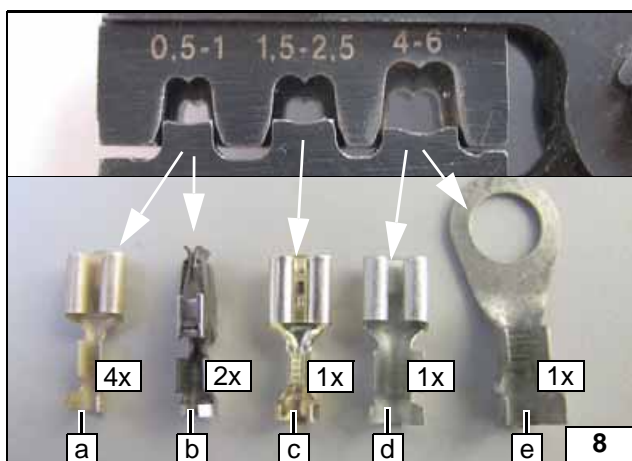

- a Contact 6.3 wire range 0,5 - 1 mm<sup>2</sup>
- b Contact 4.8 (fuse) wire range 0,5 - 1 mm<sup>2</sup>
- c Contact 6.3 wire range 1,5 - 2,5 mm<sup>2</sup>
- d Contact 6.3 wire range 4,0 - 6,0 mm<sup>2</sup>
- e Cable lug Ø 8 wire range 4,0 - 6,0 mm<sup>2</sup>

List contact

8

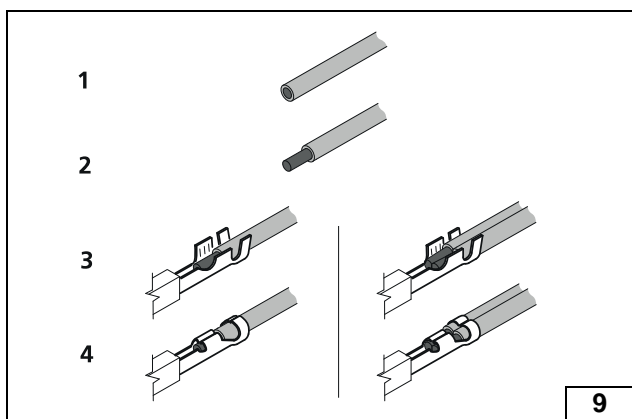

Instruction  
connect  
contacts

9



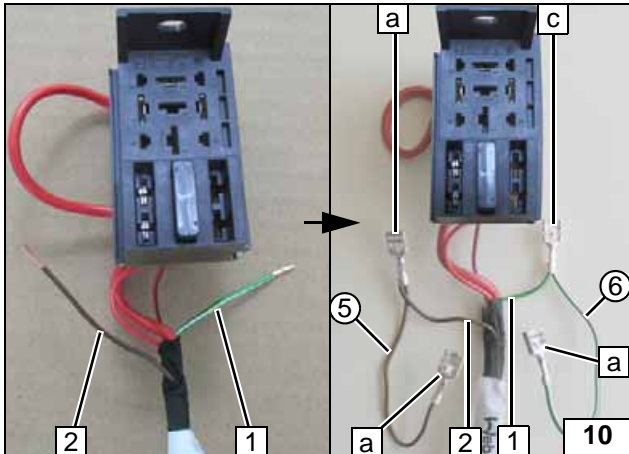

Remove contacts of wire BR 2 and wire G/W 1. Connect wires with contact a and c.



- 1 Wire G/W from wiring harness relay and fuse holder (passenger compartment) K1/86
- 2 Wire BR from wiring harness relay and fuse holder (passenger compartment) K1/85
- 5 Wire BR for PWM GW/GND
- 6 Wire G/W for PWM GW/SH

Preparing wires for Relay and fuse holder in passenger compartment

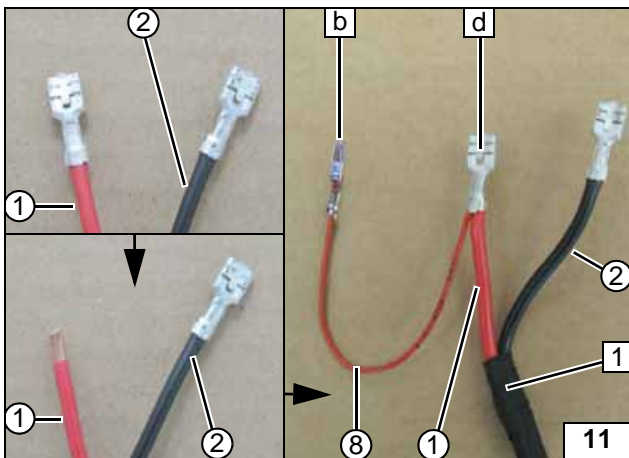

Remove contact of wire R 1 blower wiring harness. Connect wire at contact b and d.



- 1 Blower wiring harness
- 1 Wire R 4mm<sup>2</sup> blower wiring harness for K1/87a
- 2 Wire B 4mm<sup>2</sup> blower wiring harness for K1/30
- 8 Wire R from K1/87a to fuse F5

Preparing blower wiring harness

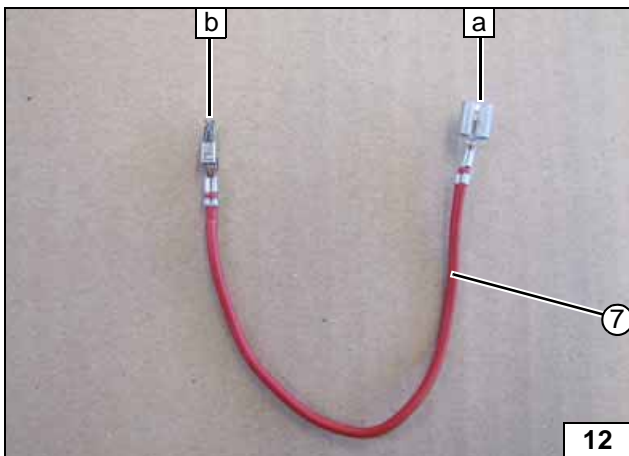

Connect wire at contact b and a.



- 7 Wire R from fuse F5 to PWM GW/KL15

Preparing wire 7



Version 2 (5-pole relay socket)

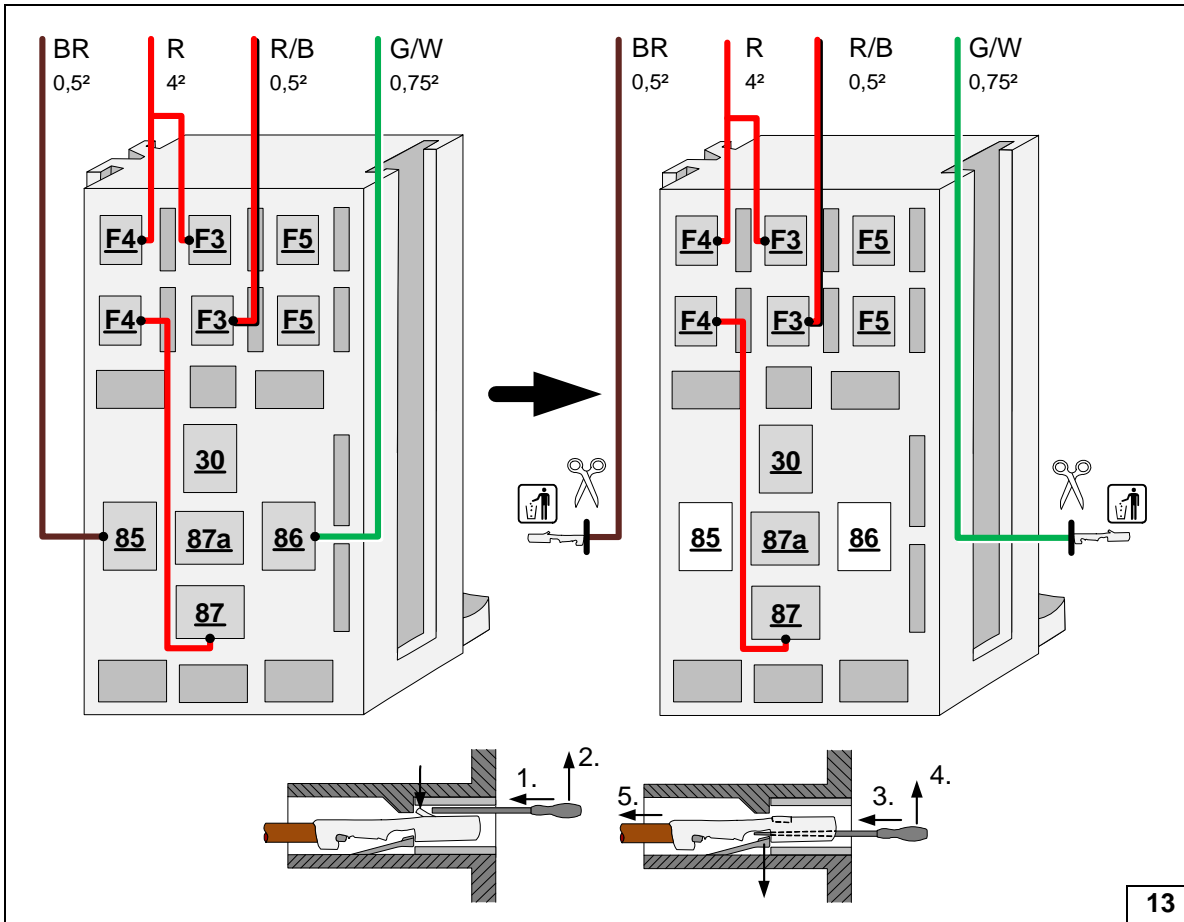

Detach contacts  
Relay and fuse  
holder in  
passenger  
compartment /  
Version 2

13

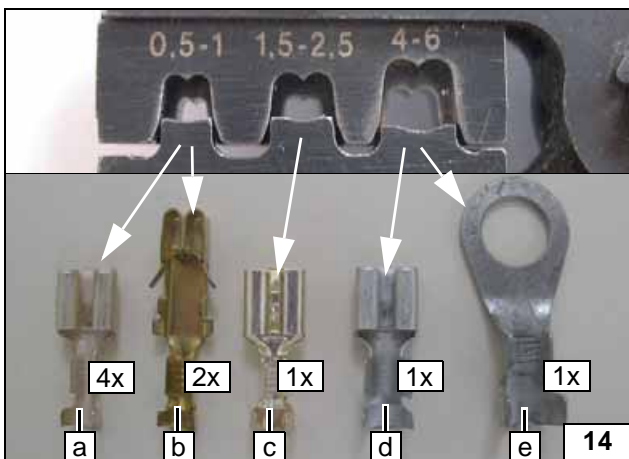

- a Contact 6.3 wire range 0,5 - 1 mm<sup>2</sup>
- b Contact 4.8 (fuse) wire range 0,5 - 1 mm<sup>2</sup>
- c Contact 6.3 wire range 1,0 - 2,5 mm<sup>2</sup>
- d Contact 6.3 wire range 4,0 - 6,0 mm<sup>2</sup>
- e Cable lug Ø 8 wire range 4,0 - 6,0 mm<sup>2</sup>

List contact

14

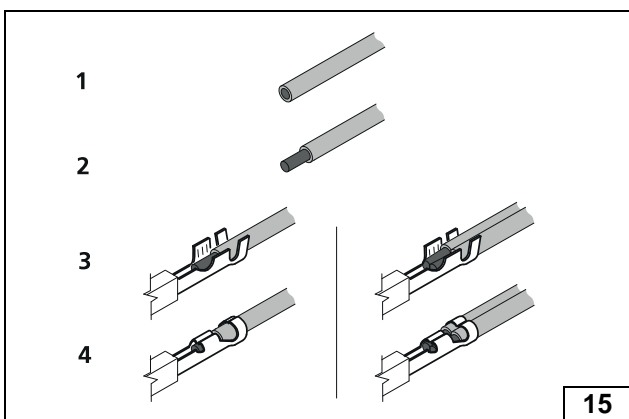

15

Instruction  
connect  
contacts

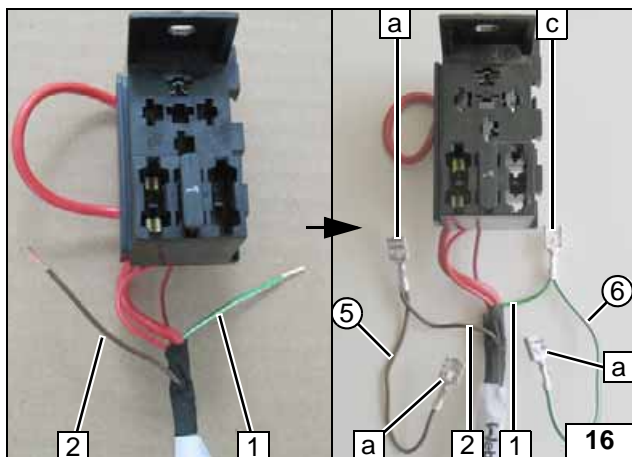

Remove contacts of wire BR 2 and wire G/W 1. Connect wires with contact a and c.

- 1 Wire G/W from wiring harness relay and fuse holder (passenger compartment) K1/86
- 2 Wire BR from wiring harness relay and fuse holder (passenger compartment) K1/85
- 5 Wire BR for PWM GW/GND
- 6 Wire G/W for PWM GW/SH

Preparing wires for Relay and fuse holder in passenger compartment

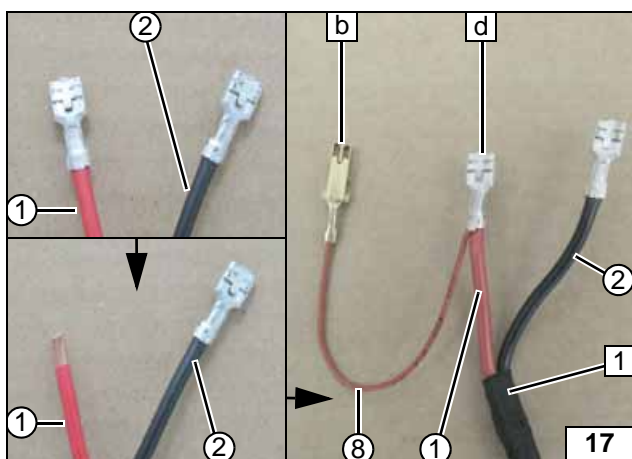

Remove contact of wire R 1 blower wiring harness. Connect wire at contact b and d.

- 1 Blower wiring harness
- 1 Wire R 4mm<sup>2</sup> blower wiring harness for K1/87a
- 2 Wire B 4mm<sup>2</sup> blower wiring harness for K1/30
- 8 Wire R from K1/87a to fuse F5

Preparing blower wiring harness

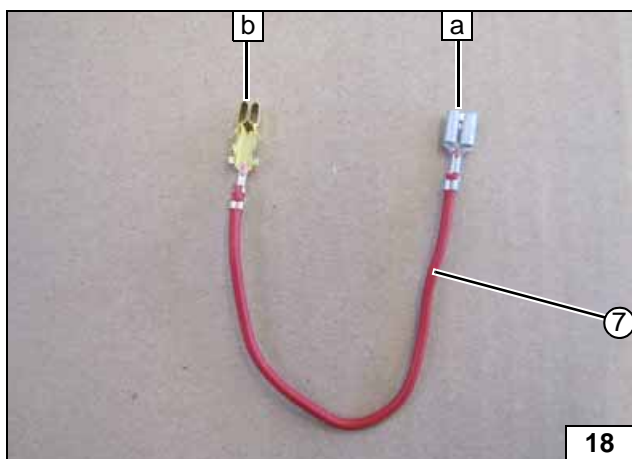

Connect wire at contact b and a.

- 7 Wire R from fuse F5 to PWM GW/KL15

Preparing wire 7

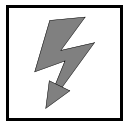

All Versions



Connecting wires to Relay and fuse holder (passenger compartment) / All Versions

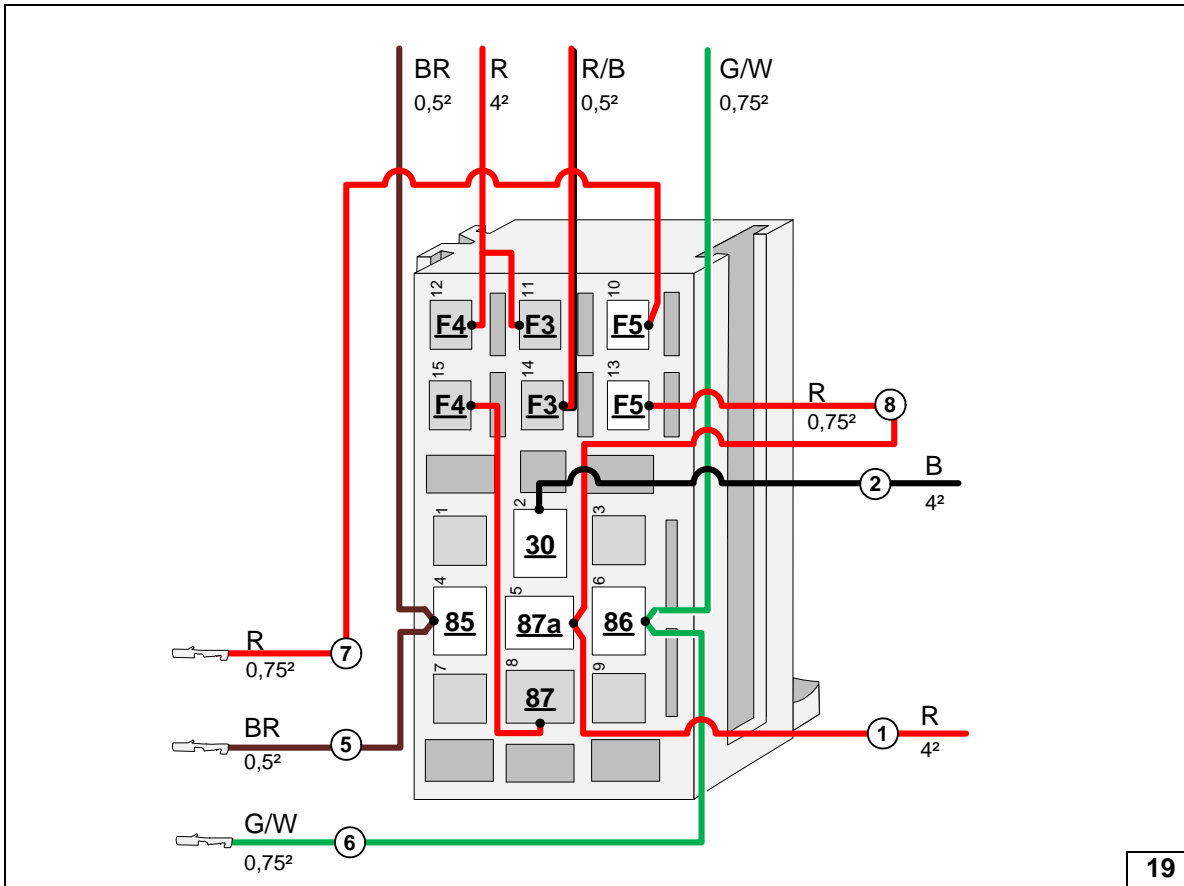

Interlocking socket PWM GW and relay and fuse holder (passenger compartment) / connecting wires to socket PWM GW / All Versions

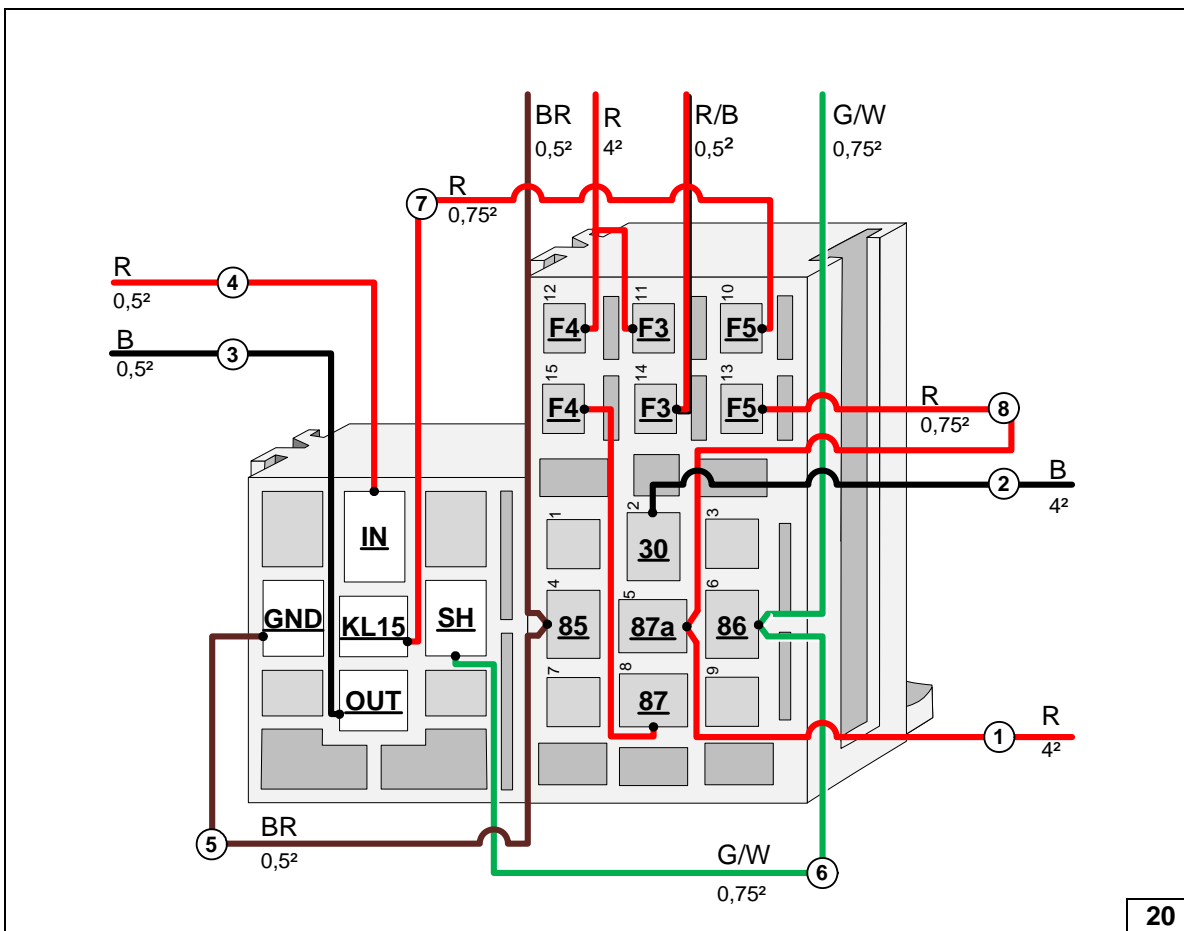

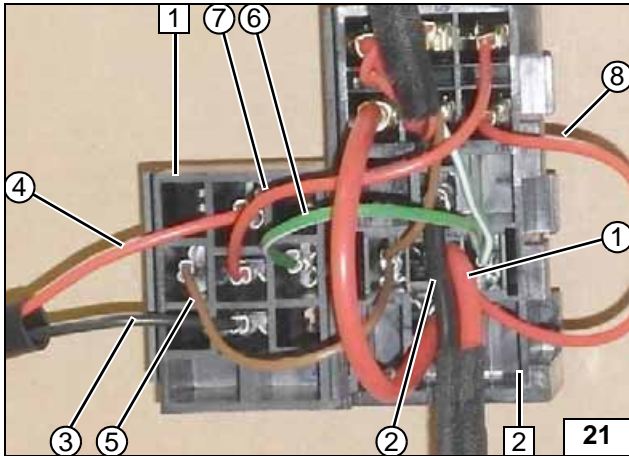
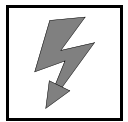

- 1 Relay and fuse holder (passenger compartment)
- 2 PWM GW socket
- ① Wire R from K1/87a blower wiring harness
- ② Wire B from K1/30 blower wiring harness
- ③ Wire B wiring harness PWM GW/OUT
- ④ Wire R wiring harness PWM GW/IN
- ⑤ Wire BR from K1/85 and PWM GW/GND
- ⑥ Wire G/W from K1/86 and PWM GW/SH
- ⑦ Wire R from fuse F5 and PWM GW/KL15
- ⑧ Wire R from K1/87a and fuse F5



**View relay and fuse holder (passenger compartment)**

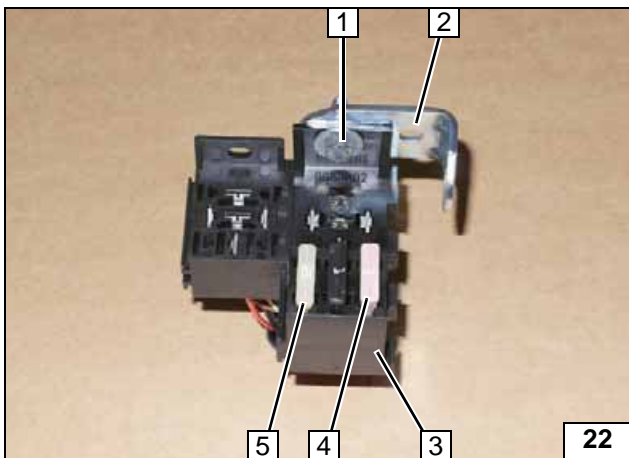

PWM GW and K1 relay will be inserted after the installation of the relay and fuse holder in passenger compartment.



- 1 M5x16 bolt, large diameter washer [2x], nut (5-6Nm)
- 2 Angle bracket
- 3 Relay and fuse holder (passenger compartment)
- 4 3A fuse F5 attached
- 5 25A fuse F4 attached

**Preparing relay and fuse holder (passenger compartment)**

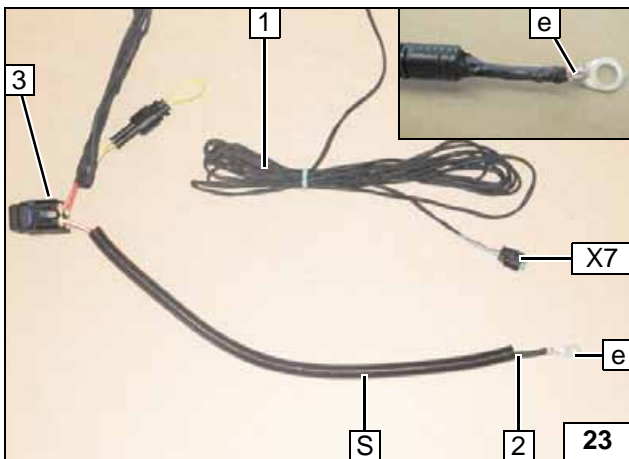

Mount corrugated tube Ø 10 S to protect on B+ wire R.  
Cable lug e on positive wire R 2.



- 1 Wiring harness of metering fuel pump
- 2 B+ wire R
- 3 Fuse holder in engine compartment
- X7 Connector wiring harness of metering pump

**Preparing the wiring harness**

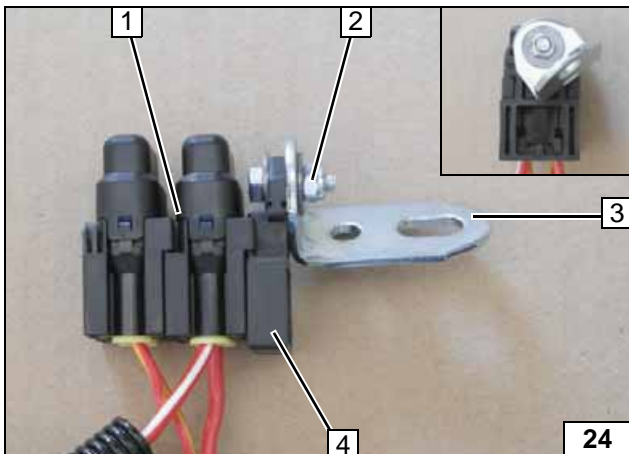

- 1 Fuses F1-2
- 2 M5x12 bolt, large diameter washer [2x], nut (5-6 Nm)
- 3 Angle bracket
- 4 Retaining plate of fuse holder

**Preparing plate of fuse holder**



25

**PWM GW**

**PWM GW =** Pulse Width Module Gateway

The PWM GW is pre-programmed for blower level 3. However, the speed of the blower on the vehicle may differ for technical reasons. In case of a too low / high blower power, the PWM GW can be reprogrammed using the Webasto diagnosis. See „Final Work“.

**View of PWM GW**

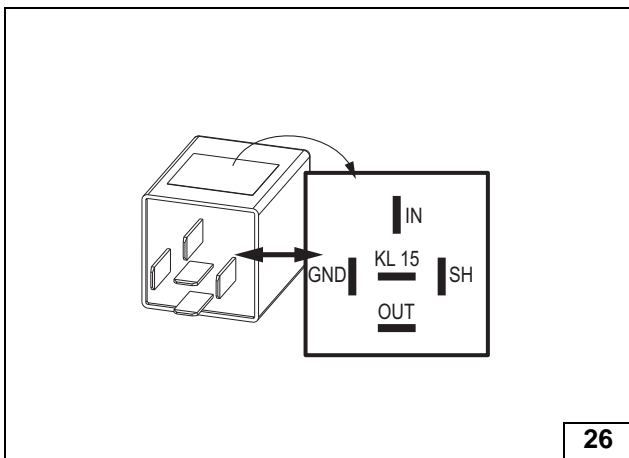

26

**Settings:**

- Duty-Cycle: 70%
- Frequency: 500Hz
- Voltage: not relevant
- Function: Low-side

**View PWM GW**



**Electrical System**

**Positive wire**

- 1 Route positive wire R in corrugated tube Ø 10 S to positive battery terminal (for connection to positive battery terminal, see section „Final Work“)

**Earth wire**

- 1 Earth wire on earth support point
- 2 Original vehicle earth support point

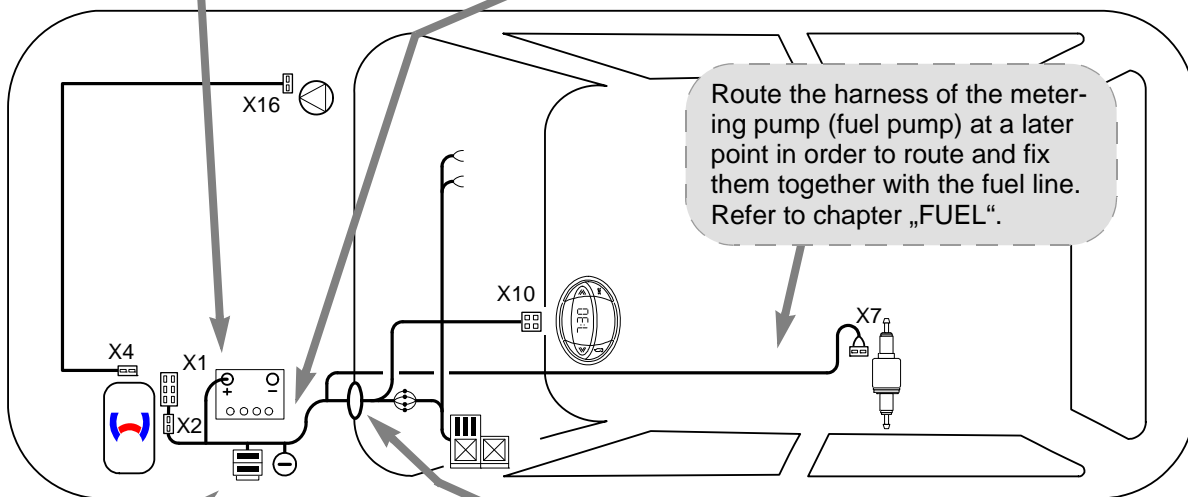
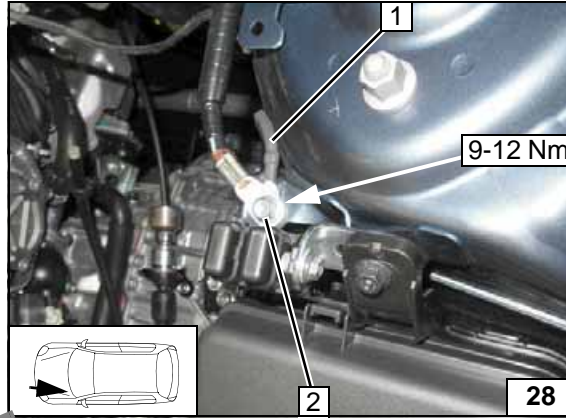
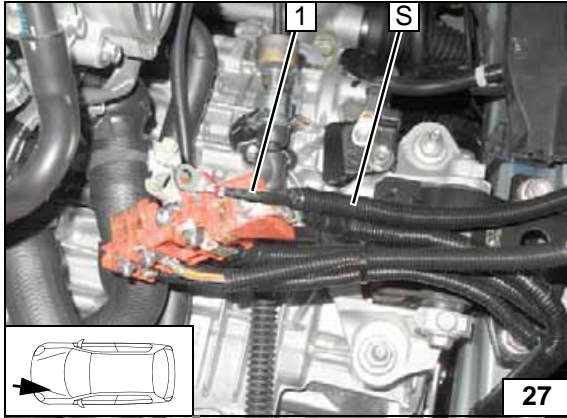

**Wiring harness routing diagram**

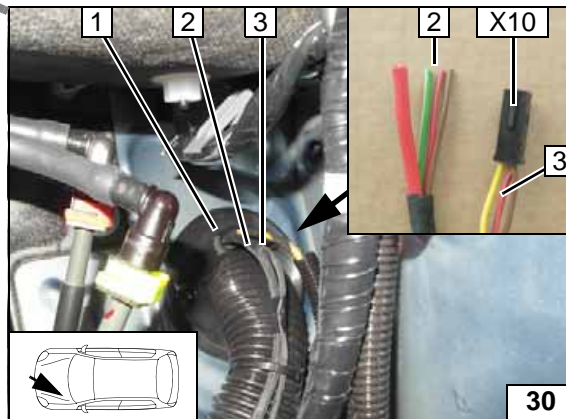
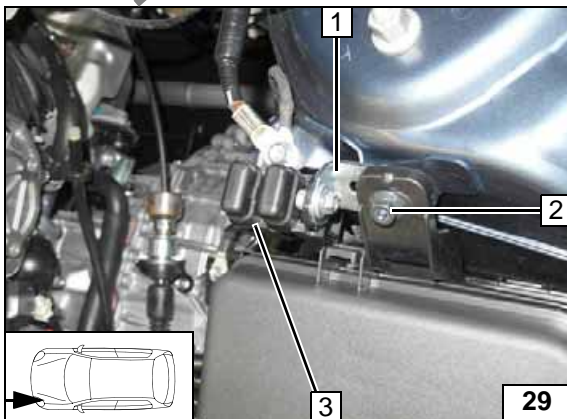

**Fuse holder in engine compartment**

- 1 Angle bracket
- 2 Original vehicle bolt (8-10Nm)
- 3 Fuses F1-2

**Wiring harness pass through**

- 1 Vehicle grommet
- 2 Cable harnesses for the blower control
- 3 Cable harnesses for the heater control



Blower Fan Control

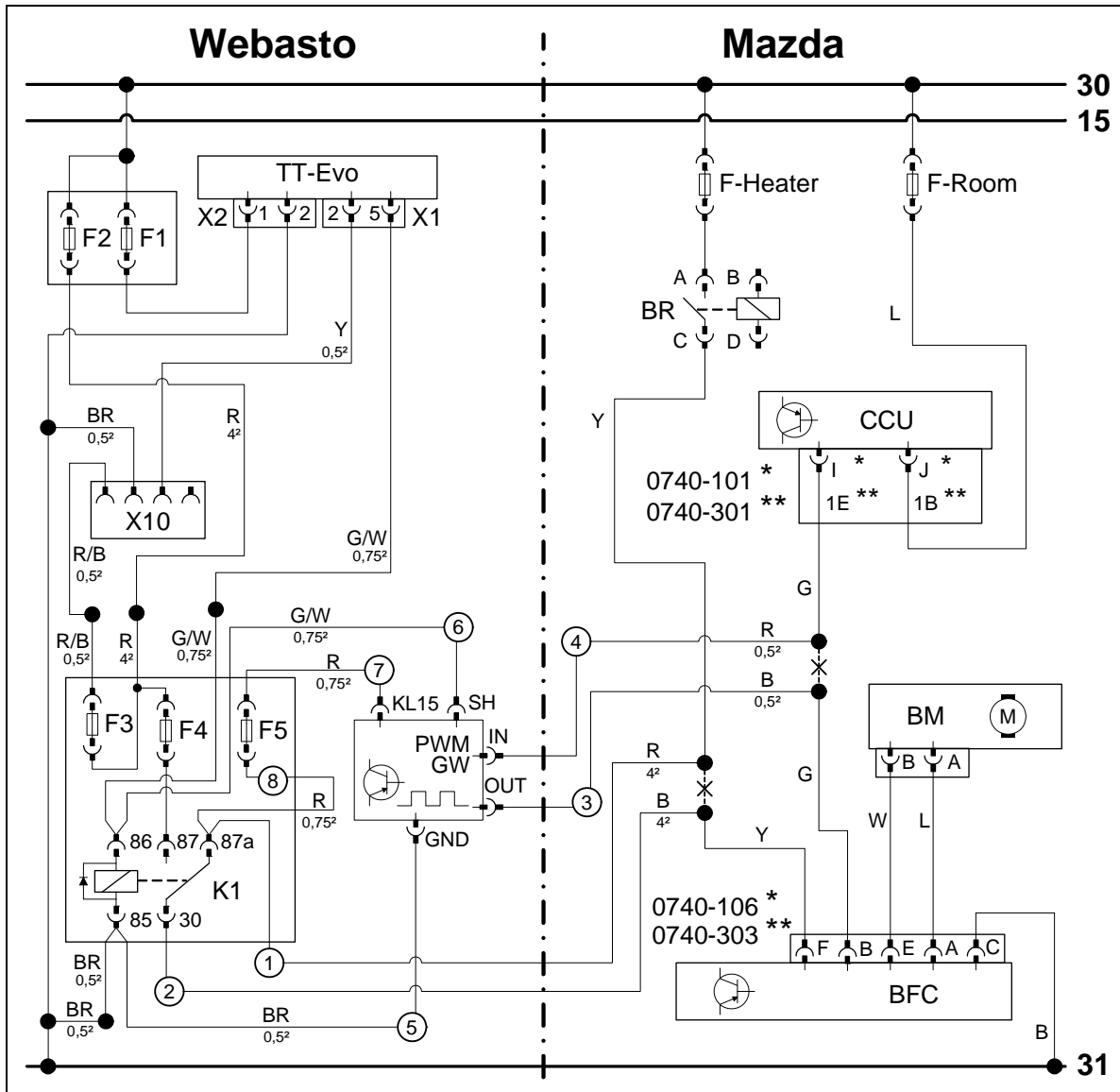

Wiring diagram  
MANUAL AC (AC)  
and  
AUTO AC (AAC)

Webasto components		Vehicle components		Colours and symbols	
TT-Evo	Heater TT-Evo	F- Heater	40A fuse	R	red
X1	6-pin heater connector	F- Room	15A fuse	B	black
X2	2-pin heater connector	BR	Blower Relay	Y	yellow
F1	20A fuse	CCU	Climate Control Unit	G	green
F2	30A fuse	0740-101	Connector CCU A/C (7-speed)	BR	brown
X10	4-pin heater control connector	0740-301	Connector CCU AAC (dual type)	W	white
F3	1A fuse	BM	Blower Motor	L	blue
F4	25A fuse	BFC	Blower Fan Controller		
F5	3A fuse	0740-106	6-pin connector BFC A/C (7-speed)		
PWM GW	PWM Gateway	0740-303	6-pin connector BFC AAC (dual type)	*	MANUAL AC
K1	Blower relay			**	AUTO AC
<b>PWM GW settings:</b>				X	Cutting point
Duty-Cycle: 70%				Wiring colours may vary.	
Frequency: 500Hz					
Voltage: not relevant					
Function: Low-side					

Legend



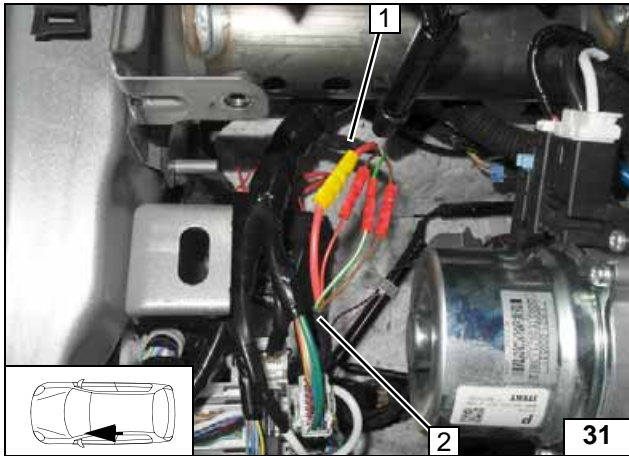

Cable R (4,0mm<sup>2</sup>) with R (4,0mm<sup>2</sup>)  
 Cable R/B (0,5mm<sup>2</sup>) with R/B (0,5mm<sup>2</sup>)  
 Cable G/W (0,75mm<sup>2</sup>) with G/W (0,75mm<sup>2</sup>)  
 Cable BR (0,5mm<sup>2</sup>) with BR (0,5mm<sup>2</sup>)

- 1 Wiring harness of relay and fuse holder (passenger compartment)
- 2 Wiring harness of heater



**Connecting wiring harnesses, ensuring that the colours match**

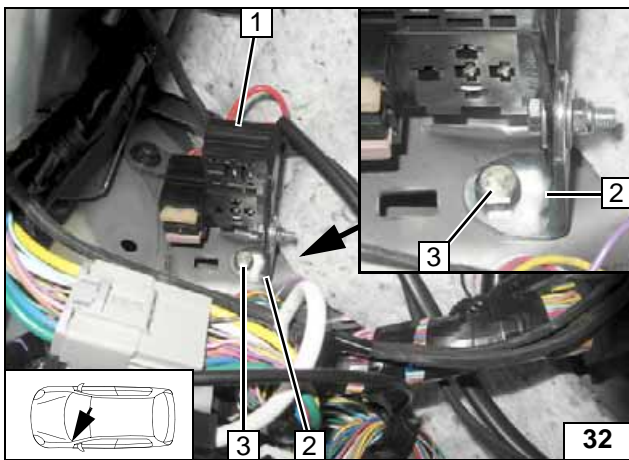

- 1 Relay and fuse holder (passenger compartment)
- 2 Perforated angle
- 3 Bolt M6x20, spring lockwasher, existing threaded hole (8-10Nm)



**Installing relay and fuse holder (passenger compartment)**

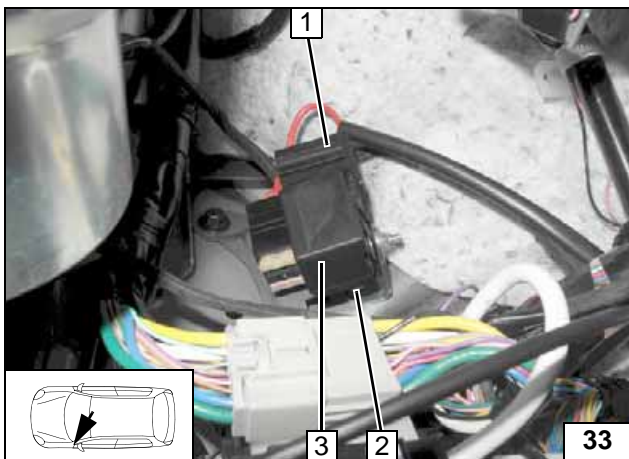

- 1 Relay and fuse holder (passenger compartment)
- 2 K1 relay (concealed behind relay and fuse holder (passenger compartment))
- 3 PWM GW



**Installing relay K1 and PWM GW**

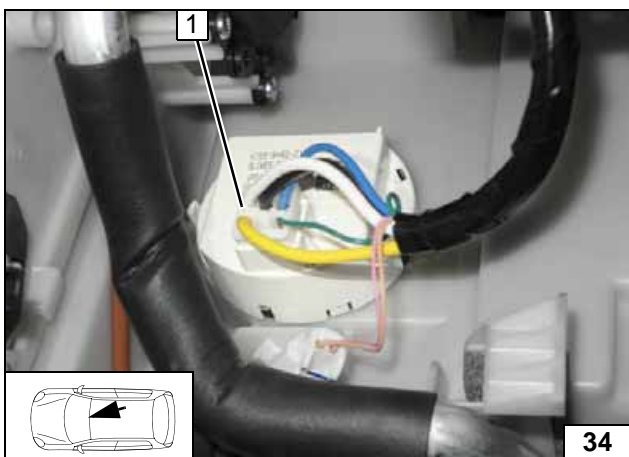

Air-channel removed for documentation!

- 1 6-pin connector Blower Fan Controller:  
 - 0740-106 (A/C 7-speed)  
 - 0740-303 (AAC dual type)



**Connector Blower Fan Controller**

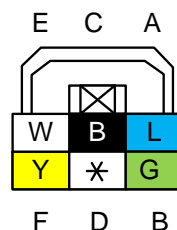

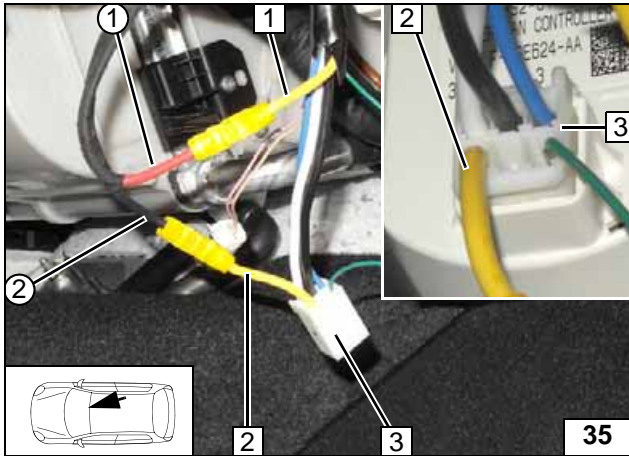

Connection on 6-pin connector **3** from Blower Fan Controller.

- 1** Wire Y from Blower relay pin C
- 2** Wire Y to 6-pin connector Blower Fan Controller pin F
- ① Wire R from K1/87a blower wiring harness
- ② Wire B from K1/30 blower wiring harness



**Connecting of Blower Fan Controller**

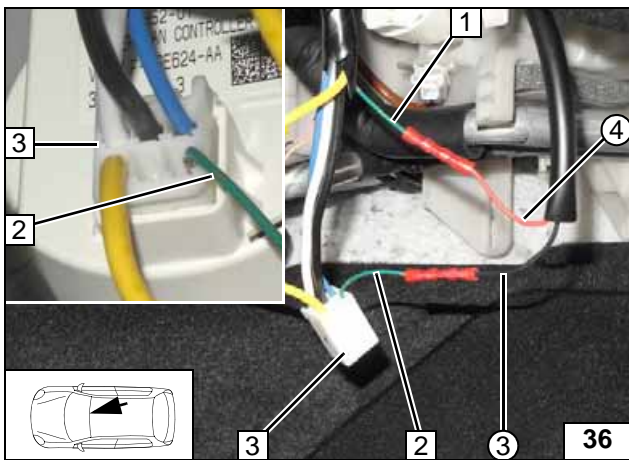

Connection on 6-pin connector **3** from Blower Fan Controller.

- 1** Wire G from CCU/ pin I/1E:  
- 0740-101 (A/C 7-speed)  
- 0740-301 (AAC dual type)
- 2** Wire G to connector BFC/ pin B:  
- 0740-106 (A/C 7-speed)  
- 0740-303 (AAC dual type)
- ③ Wire B from PWM GW/OUT wiring harness PWM GW control
- ④ Wire R from PWM GW/IN wiring harness PWM GW control



**Connecting of Blower Fan Controller**

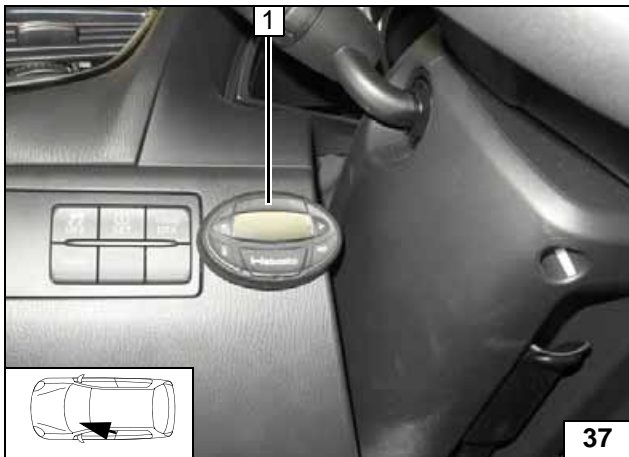

**Digital Timer**

- 1** Digital timer



**Mounting digital timer**

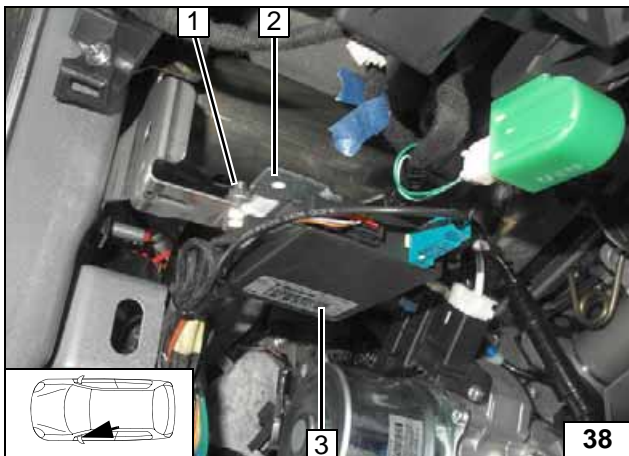

**Remote Control Option (Telestart)**

- 1** Bolt M6x20, flanged nut, existing hole (8-10Nm)
- 2** Holder receiver
- 3** Receiver



**Mounting receiver**

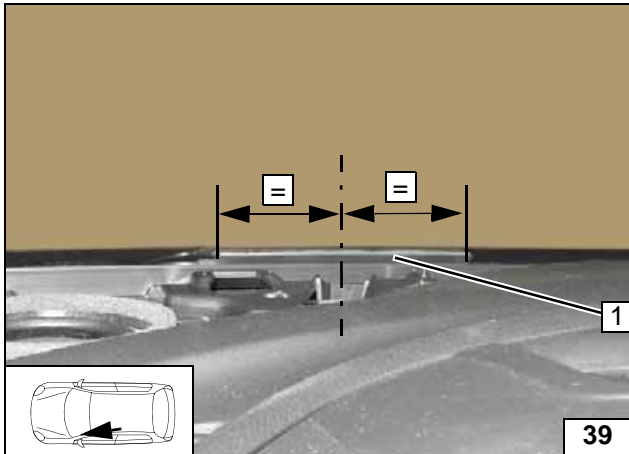

1 Antenna

Mounting antenna

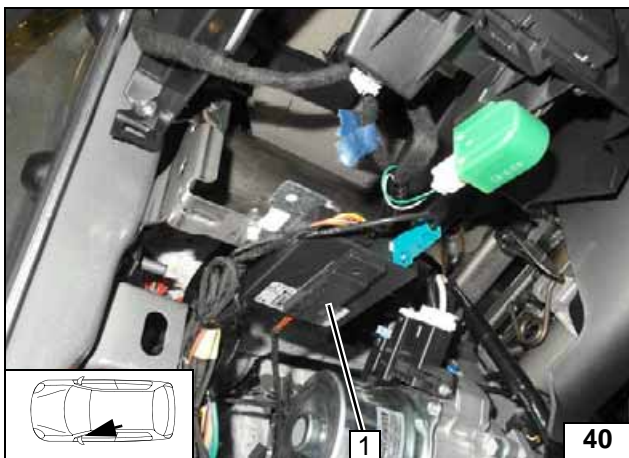

Temperature sensor, only T100 HTM

Fasten temperature sensor 1 with adhesive tape.



Installing temperature sensor

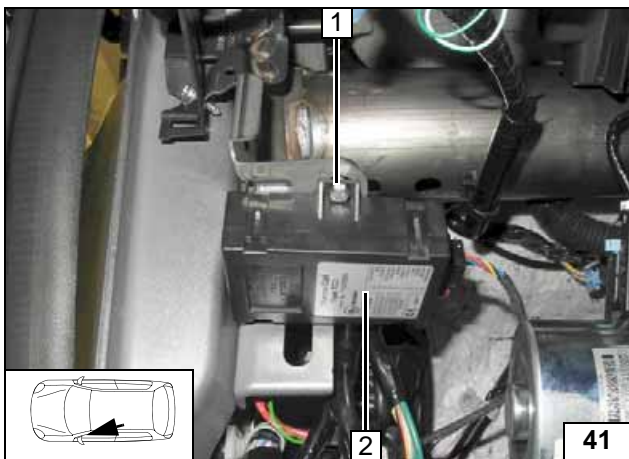

Thermo Call Option

- 1 Bolt M5x16, flanged nut, existing hole (6-8 Nm)
- 2 Receiver



Mounting receiver

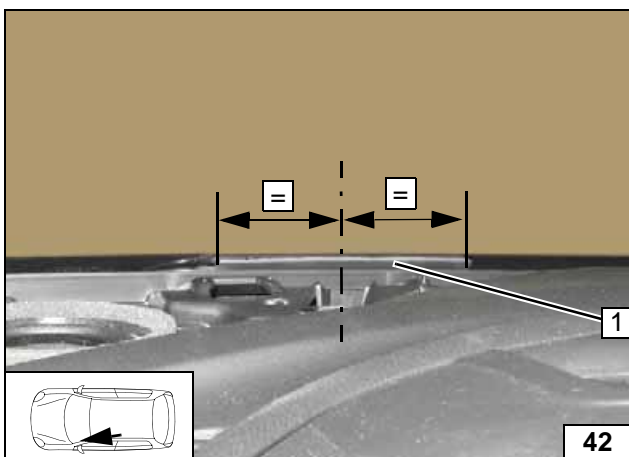

1 Antenna

Mounting antenna

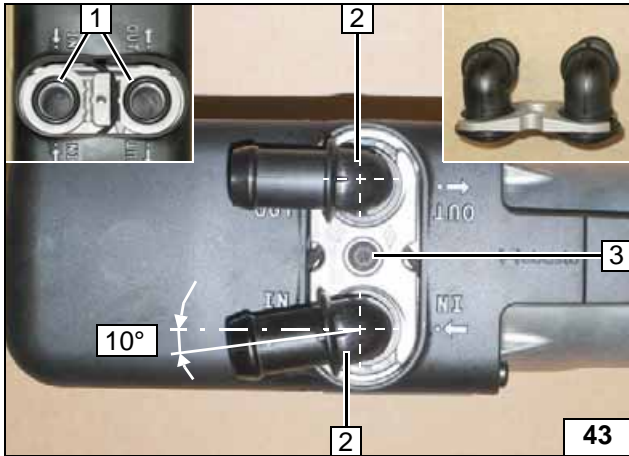
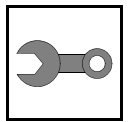

**Preparing Heater**

- 1 Sealing ring [2x]
- 2 Water connection piece [2x]
- 3 5x15 self-tapping bolt, retaining plate of water connection piece (7Nm)



**Mounting water connection piece**

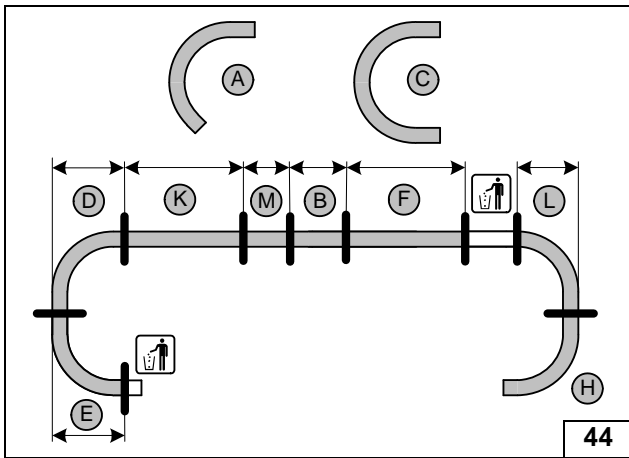

Hose **A** = moulded hose 135° Ø15 x Ø20  
 Hose **C** = moulded hose 180° Ø18

- B** = 120
- D** = 60
- E** = 60
- F** = 840
- K** = 800
- L** = 60
- M** = 100

**Cutting hoses to length**

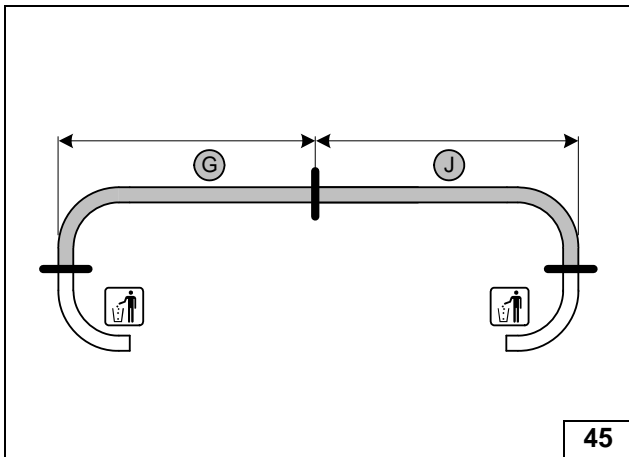

- G** = 1050
- J** = 1080

**Cutting hoses to length**

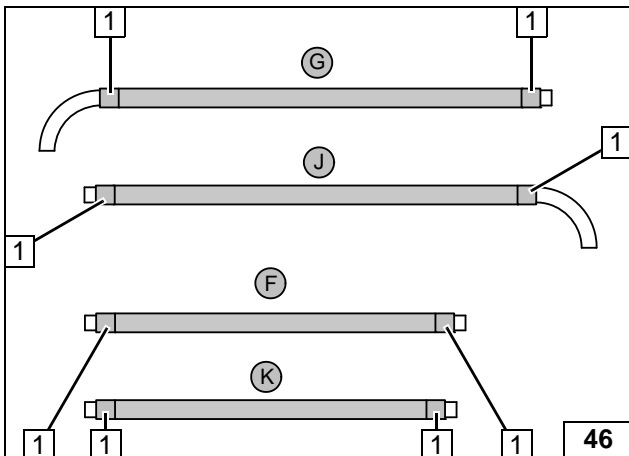

Slide braided protection hoses onto hose **G**, **J**, **F** and **K** and cut to length.  
 Cut heat shrink plastic tubing to length.

- 1 Length 40 from heat shrink plastic tubing [8x]



**Preparing hoses**

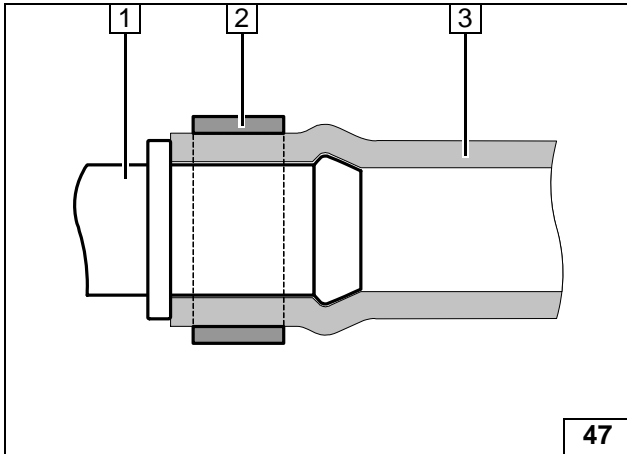

Generally mounting of connecting pipes, hoses and clamps!

- 1 Connecting pipes
- 2 Spring clamps
- 3 Hose



**Note**  
mounting  
hose

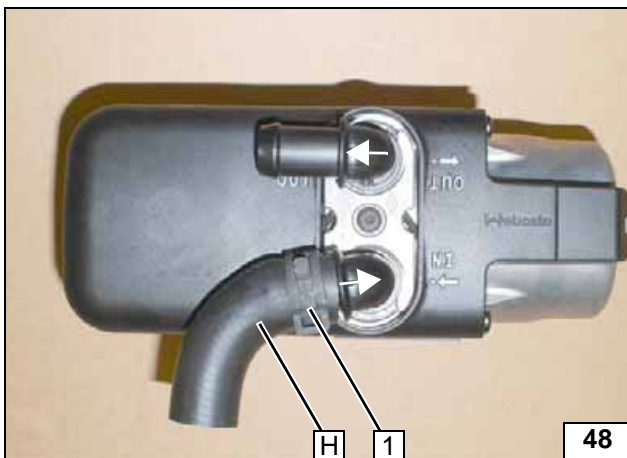

Mark direction with arrows as shown!

- 1 Spring clamp Ø 25



**Mounting**  
hose H

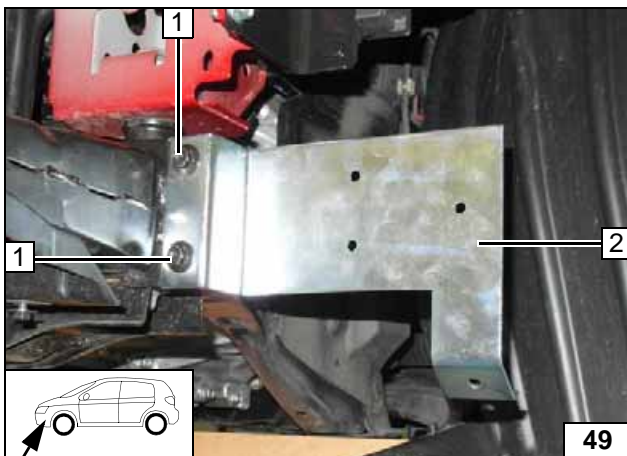

**Installing Heater**

- 1 Original vehicle bolt [2x] (8-10Nm)
- 2 Holder heater



**Mounting**  
holder

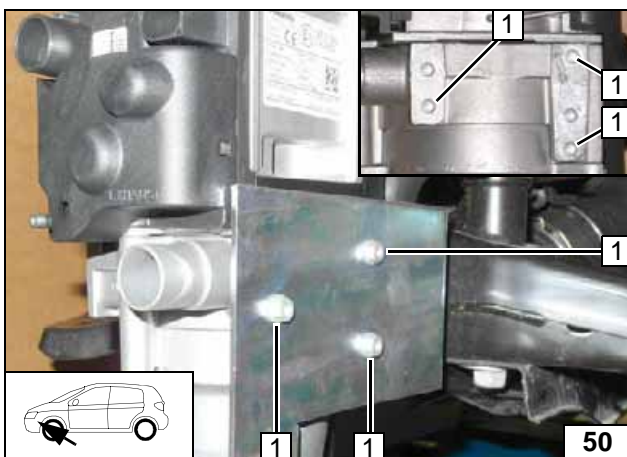

- 1 5x13 self-tapping bolt [3x] (8Nm)

**Mounting**  
heater

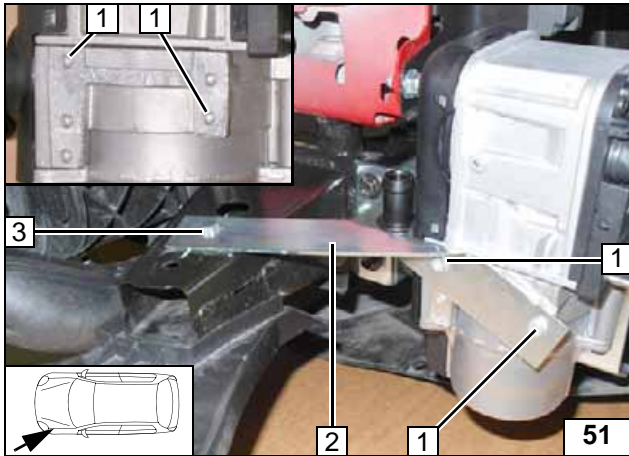
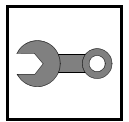

- 1 5x13 self-tapping bolt [2x] (8Nm)
- 2 Holder
- 3 M6x20 bolt, large diameter washer, flanged nut, existing hole (8-10Nm)

**Mounting holder**

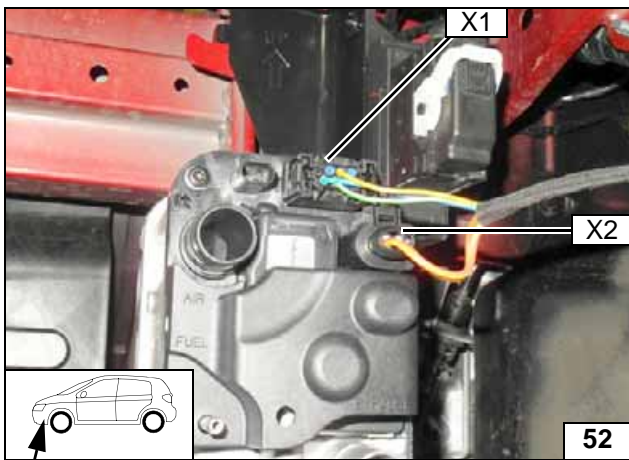

- X1 6-pin connector wiring harness heater
- X2 2-pin connector wiring harness heater

**Attaching wiring harnesses**

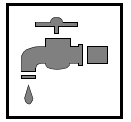

Coolant Circuit





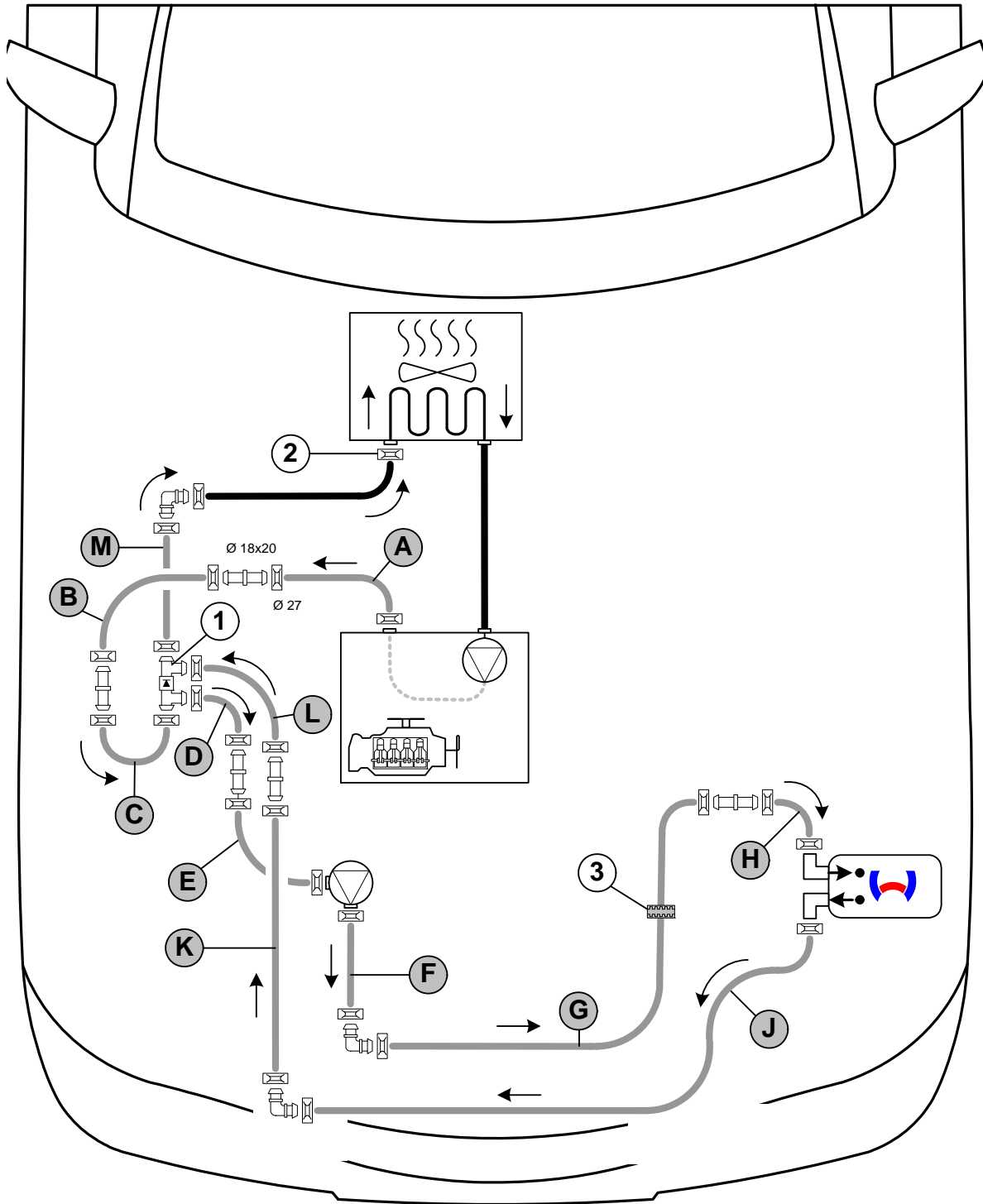

**WARNING!**

Any coolant running off should be collected using an appropriate container. Route hoses kink-free. Unless specified otherwise, always fasten using cable ties. Position clamps so that other hoses cannot be damaged. The heater must be filled with coolant when installing the hoses. The connection should be „inline“ based on the following diagram:



Hose routing diagram

All not designated spring clamps  = Ø 25! 1 = Check valve !  
 3 = rubber ring  black! 2 = original vehicle spring clamp!  
 All not designated connecting pipes  and  = Ø 18x18!



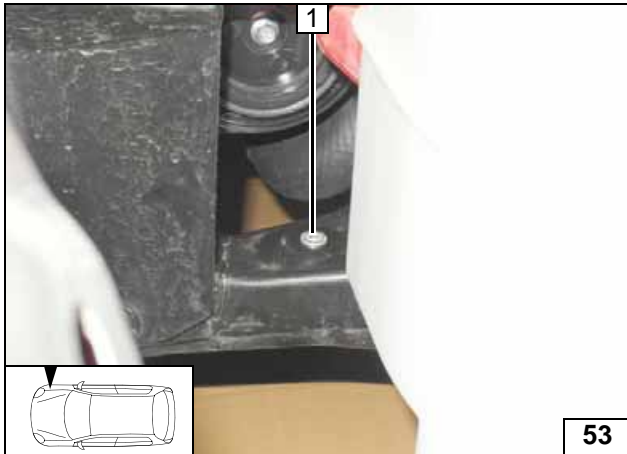

1 Rivet nut, existing hole

Installing rivet nut

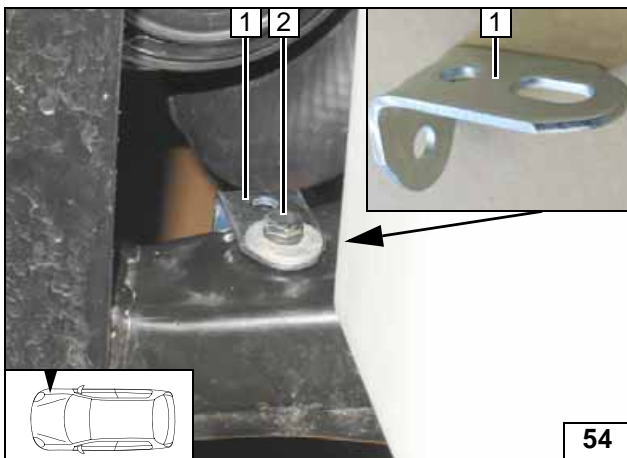

1 Angle bracket  
2 M6x20 bolt, spring lockwasher, large diameter washer (8-10Nm)

Mounting angle bracket

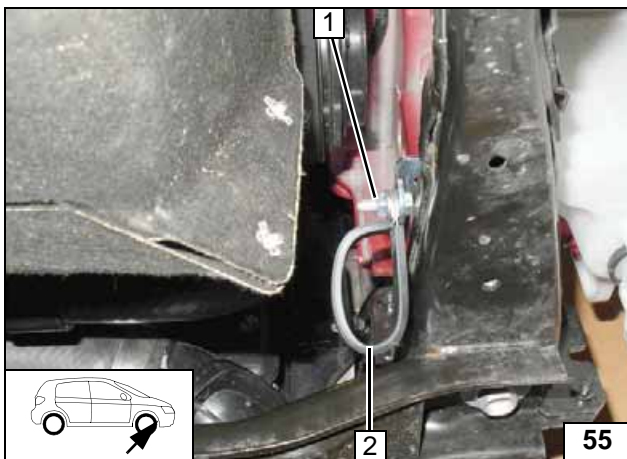

1 M6x20 bolt, flanged nut (8-10Nm)  
2 Rubber-coated p-clamp Ø 38

Installing p-clamp

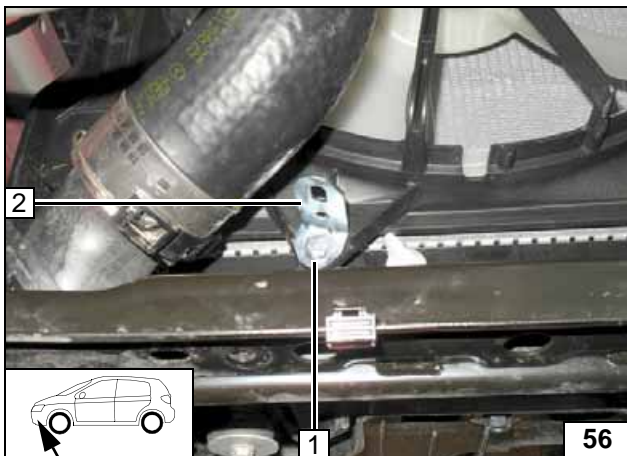

Remove and discard original vehicle bolt at position 1.

1 M6x20 bolt, spring lockwasher (8-10Nm)  
2 Angle bracket

Mounting angle bracket



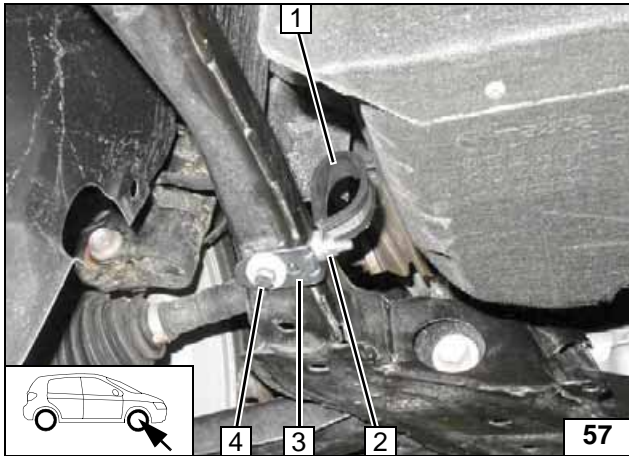

Installing M6 rivet nut in existing hole at position 4 . Loosely mount bolt 4, will be tightened together with undercover later.

- 1 Rubber-coated p-clamp Ø 38
- 2 M6x20 bolt, flanged nut (8-10Nm)
- 3 Angle bracket
- 4 M6x20 bolt, spring lockwasher, large diameter washer

Installing p-clamp

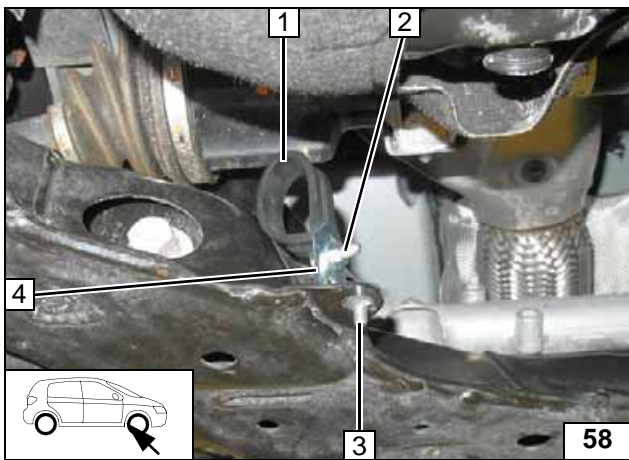

- 1 Rubber-coated p-clamp Ø 38
- 2 M6x20 bolt, flanged nut (8-10Nm)
- 3 M6x16 bolt, pin lock, existing hole
- 4 Angle bracket

Installing p-clamp

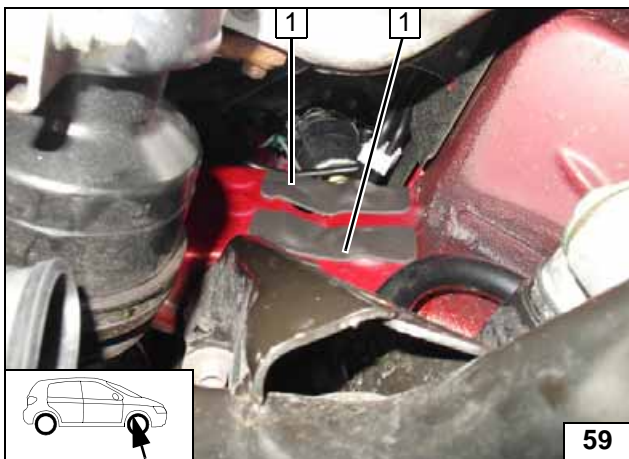

- 1 Self-adhesive foam strips [2x]

Installing rattle protection



Mark direction with arrow as shown!  
Remove original vehicle hose of engine outlet / heat ex-changer inlet 1.



Remove hose

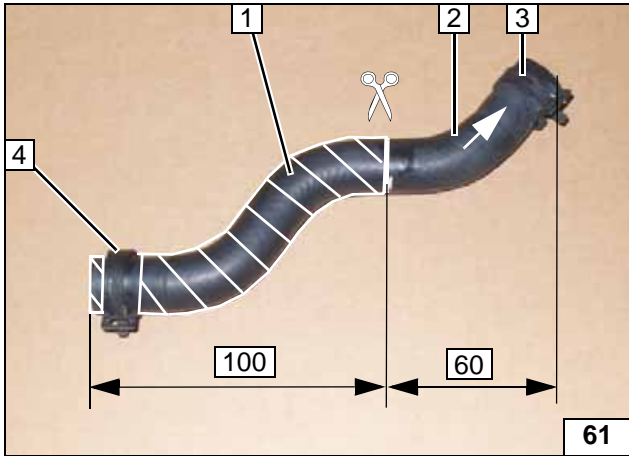

Separate hose of engine outlet / heat exchanger inlet at the marking.  
Discard original vehicle hose section 1 and original vehicle spring clamp 4.

- 2 Hose section OE-hose
- 3 Original vehicle spring clamp

Preparing hose

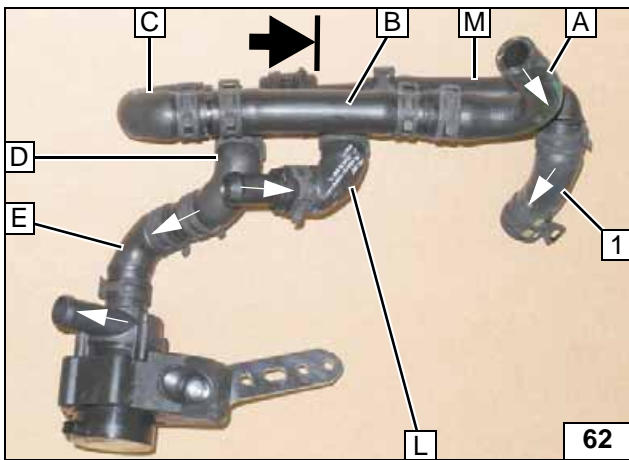

Mark direction with arrow as shown!

- 1 Hose section OE-hose

Overview mounting check valve and circulation pump

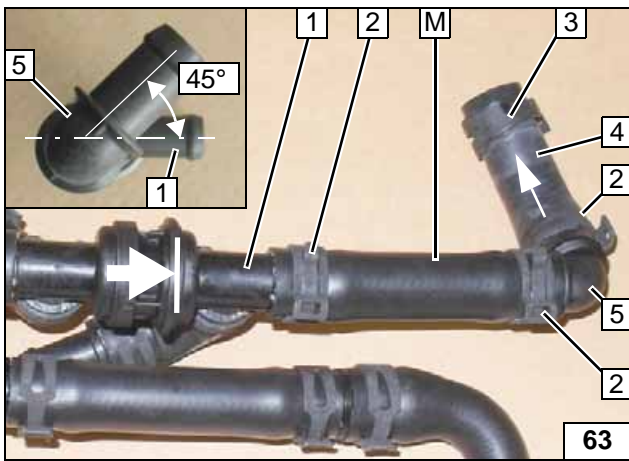

- 1 Check valve
- 2 Spring clamp Ø 25 [3x]
- 3 Original vehicle spring clamp
- 4 Hose section OE-hose
- 5 Connecting pipe Ø 18x18, 90°

Premounting check valve

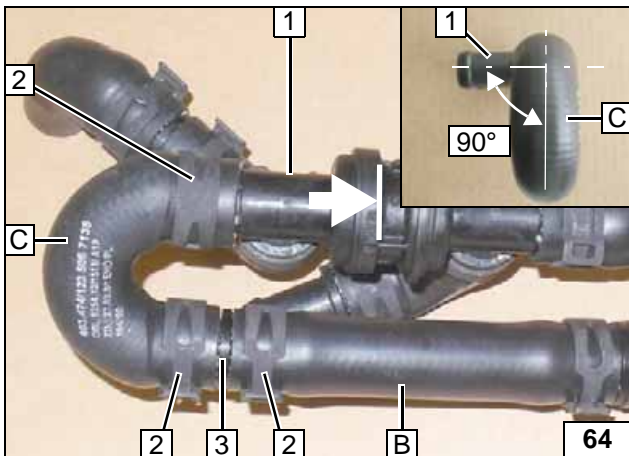

- 1 Check valve
- 2 Spring clamp Ø 25 [3x]
- 3 Connecting pipe Ø 18x18

Premounting check valve

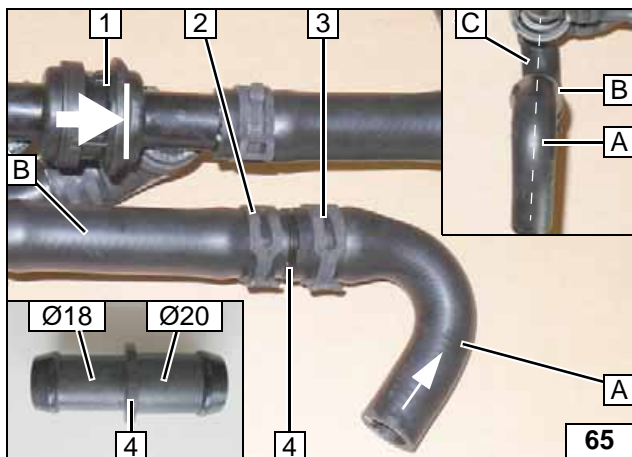

- 1 Check valve
- 2 Spring clamp Ø 25
- 3 Spring clamp Ø 27
- 4 Connecting pipe Ø 18x20

Premounting check valve

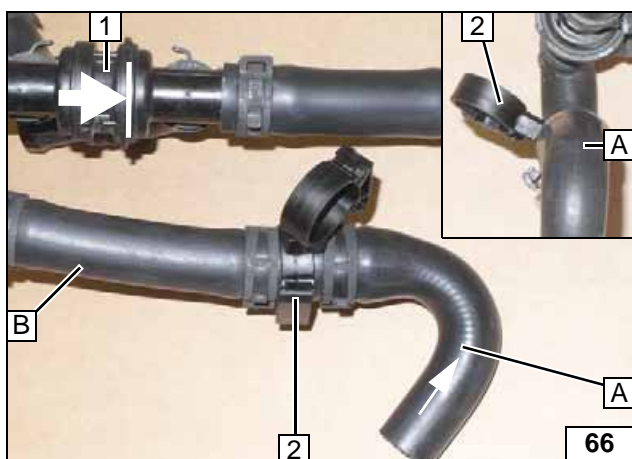

- 1 Check valve
- 2 Hose bracket Ø 25-27 on connecting pipe Ø 18x20

Mounting hose bracket

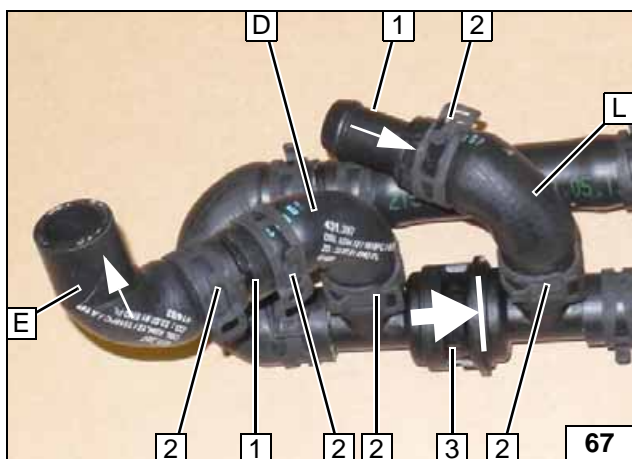

Mounting hose see the following figure.

- 1 Connecting pipe Ø 18x18 [2x]
- 2 Spring clamp Ø 25 [5x]
- 3 Check valve



Premounting check valve

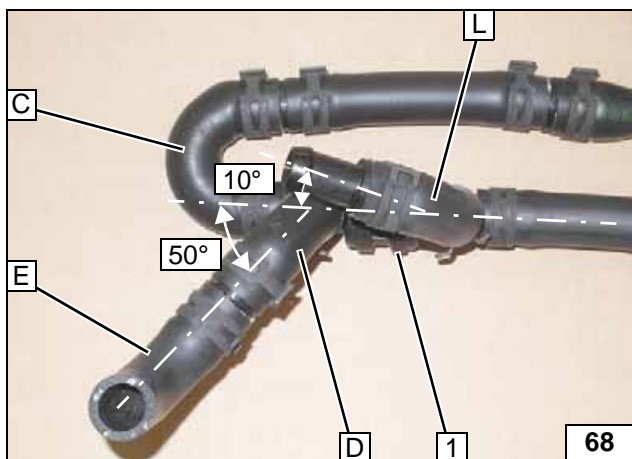

- 1 Check valve

Orientation hose

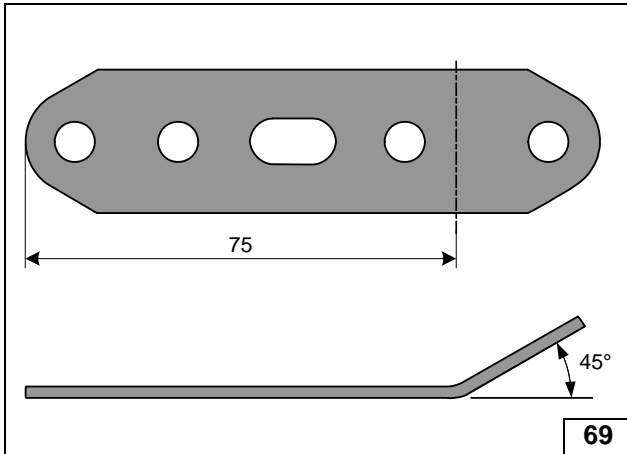

Bending down perforated bracket

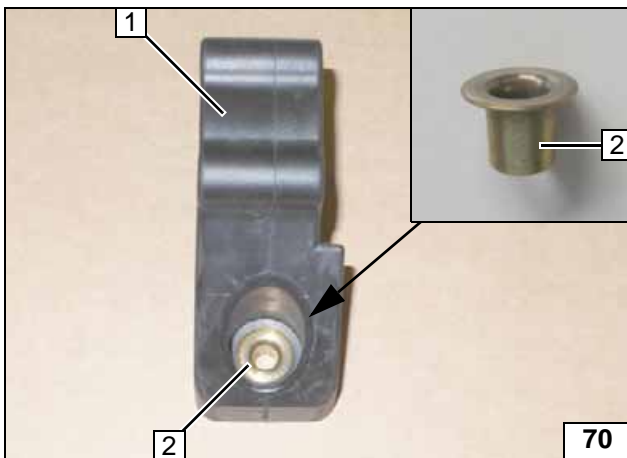

1 Rubber support of circulating pump  
2 Support rivet

Mounting support rivet

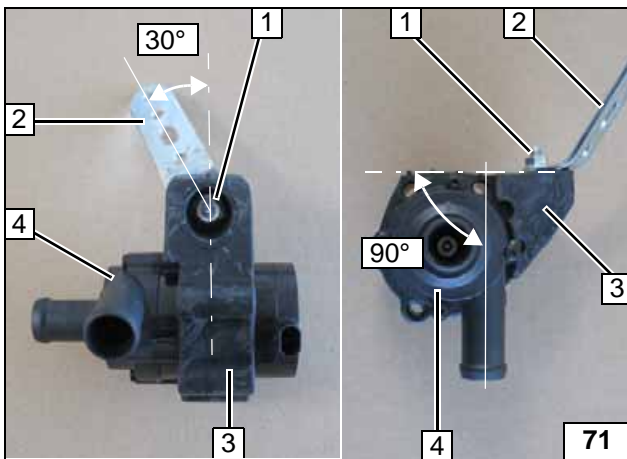

1 M6x25 bolt, flanged nut (8-10Nm)  
2 Perforated bracket  
3 Rubber support of circulating pump  
4 Circulating pump

Premounting circulating pump

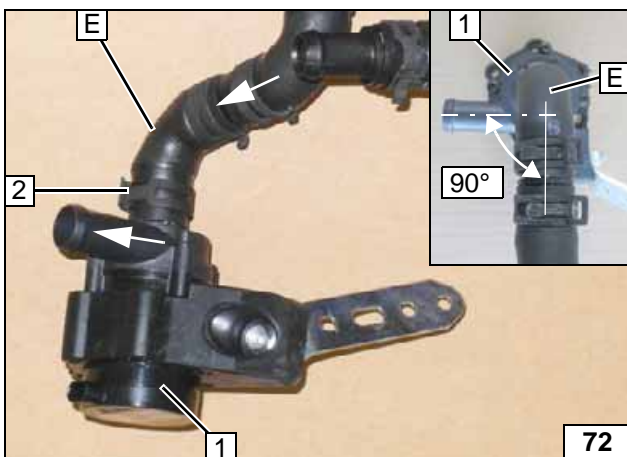

1 Circulating pump  
2 Spring clamp Ø 25

Premounting circulating pump

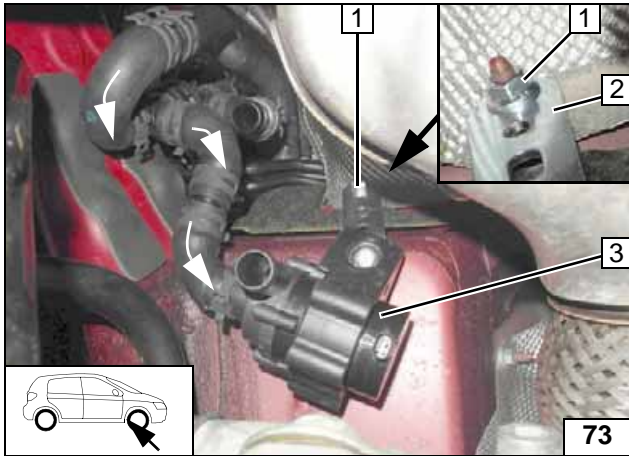

Original vehicle flanged nut at stud bolt is used as a spacer between perforated bracket **2** and the heat shield plate. Route Pre-assembled check valve to the heat exchanger.

- 1 Original vehicle stud bolt, M6 flanged nut (8-10Nm)
- 2 Perforated bracket
- 3 Circulating pump

**Mounting circulating pump**

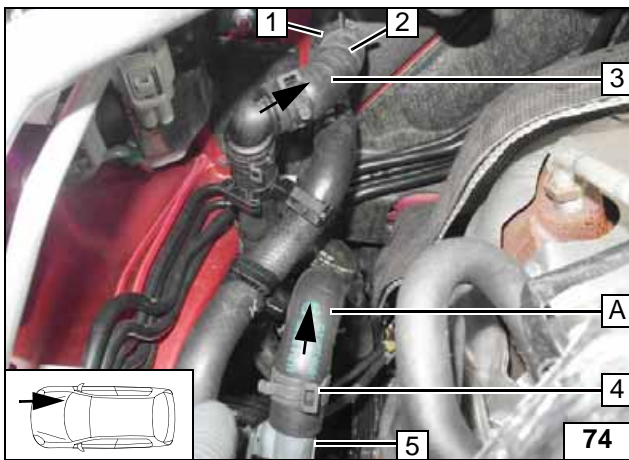

- 1 Heat exchanger inlet
- 2 Original vehicle spring clamp
- 3 Hose section OE-hose
- 4 Spring clamp Ø 25
- 5 Engine outlet

**Connection of exchanger inlet and engine outlet**

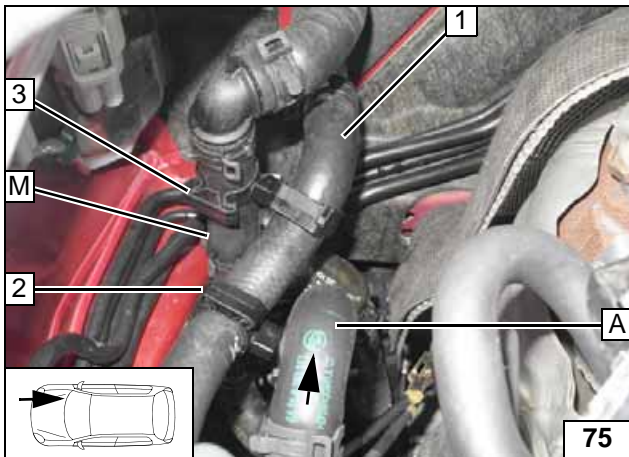

- 1 Hose heat exchanger outlet
- 2 Hose bracket Ø 25-27 on hose **A** and heat exchanger outlet **1**
- 3 Hose bracket Ø 25-27 on hose **M** and heat exchanger outlet **1**

**Mounting hose bracket**

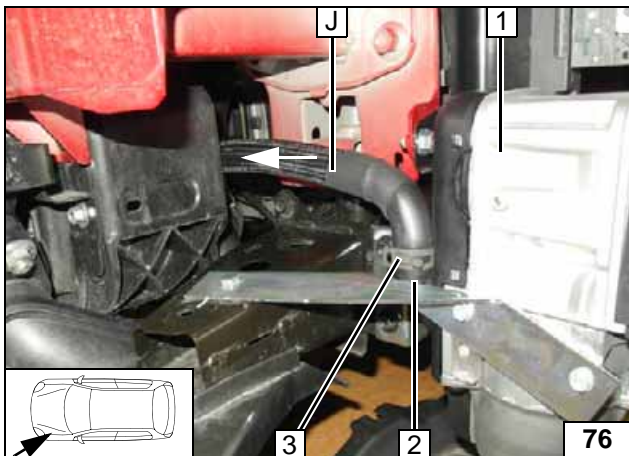

- 1 Heater
- 2 Heater outlet
- 3 Spring clamp Ø 25

**Connection heater outlet**

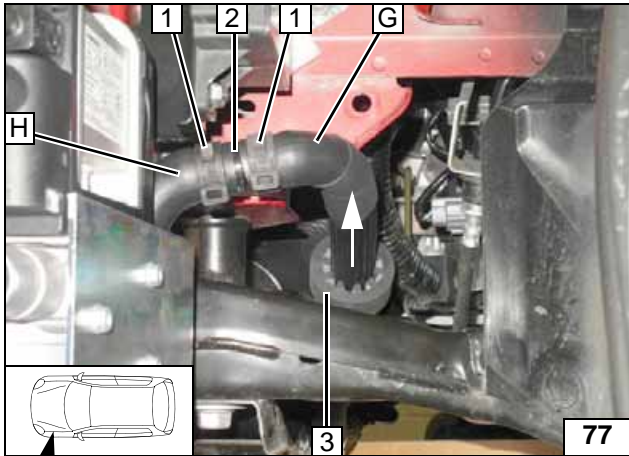

- 1 Spring clamp Ø 25 [2x]
- 2 Connecting pipe Ø 18x18
- 3 Rubber ring black

Connection heater inlet

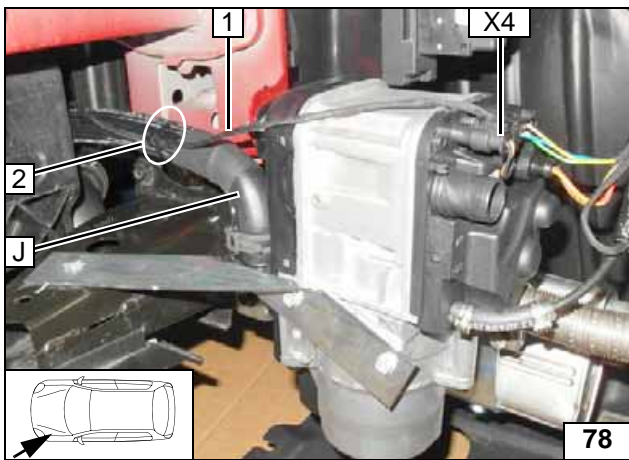

- 1 Wiring harness of circulating pump
- 2 Cable tie
- X4 Plug wiring harness of circulating pump mounted

Attaching wiring harnesses circulating pump

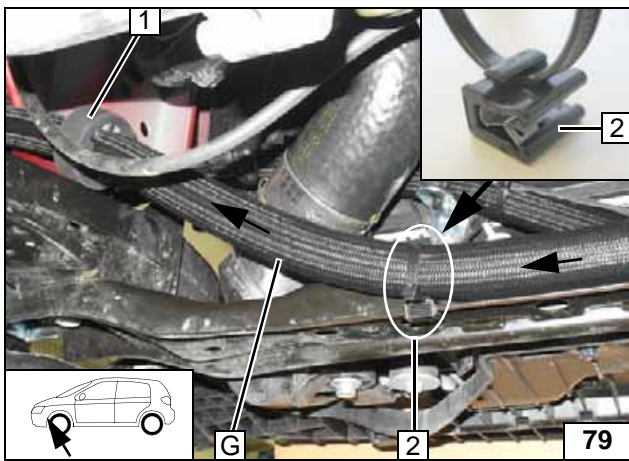

Align rubber ring black 1 an vehicle body.

- 2 Clip cable tie



Routing in engine compartment

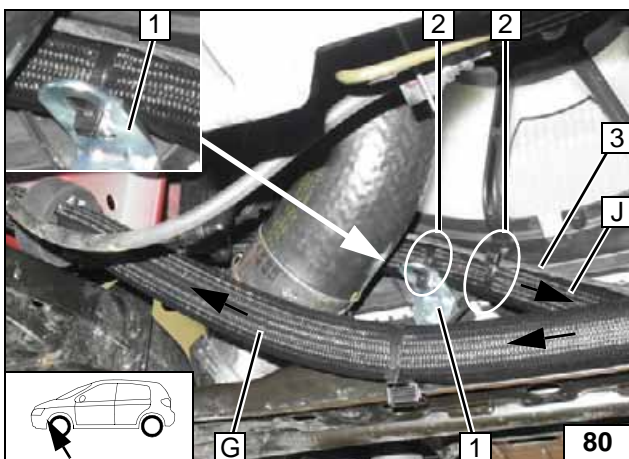

- 1 Angle bracket
- 2 Cable tie [2x]
- 3 Wiring harness of circulating pump

Routing in engine compartment

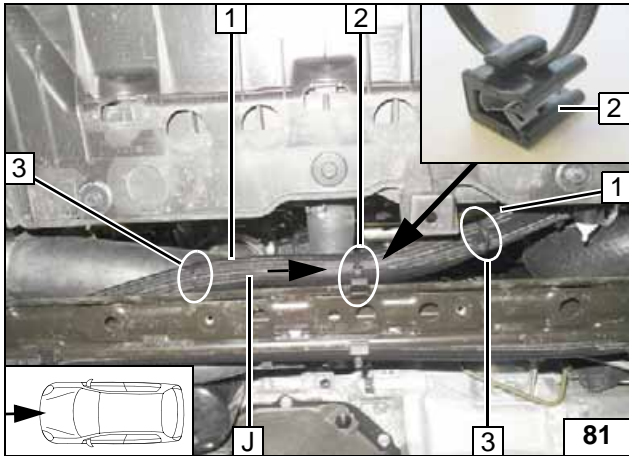

- 1 Wiring harness of circulating pump
- 2 Clip cable tie
- 3 Cable tie [2x]

Routing in engine compartment

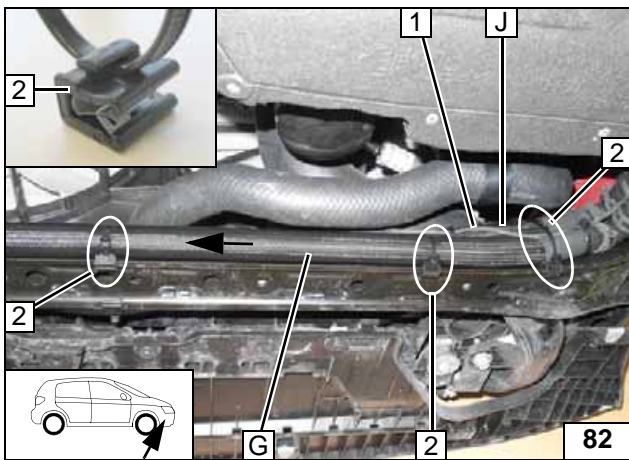

- 1 Wiring harness of circulating pump
- 2 Clip cable tie [3x]

Routing in engine compartment

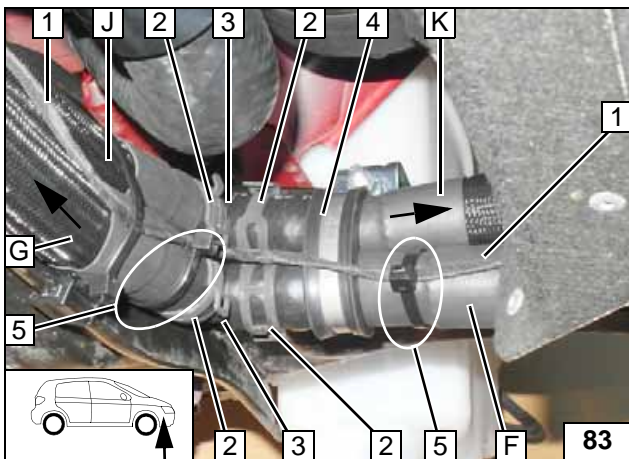

- 1 Wiring harness of circulating pump
- 2 Spring clamp Ø 25 [4x]
- 3 Connecting pipe Ø 18x18, 90° [2x]
- 4 Rubber-coated p-clamp Ø 38
- 5 Cable tie [2x]

Routing in engine compartment

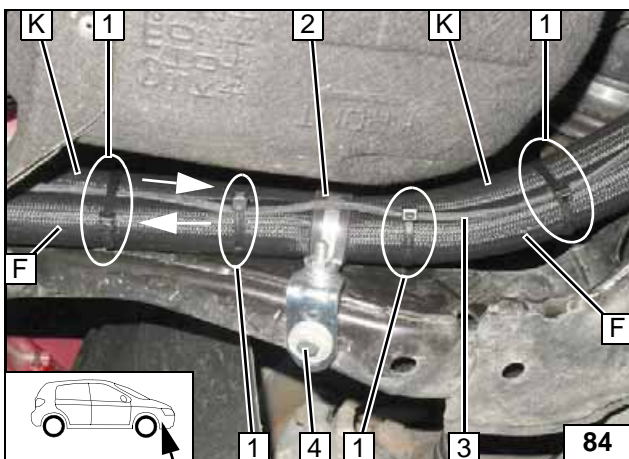

Remove bolt at position 4, will be re-installed together with undercover later.

- 1 Cable tie [4x]
- 2 Rubber-coated p-clamp Ø 38
- 3 Wiring harness of circulating pump

Routing in engine compartment

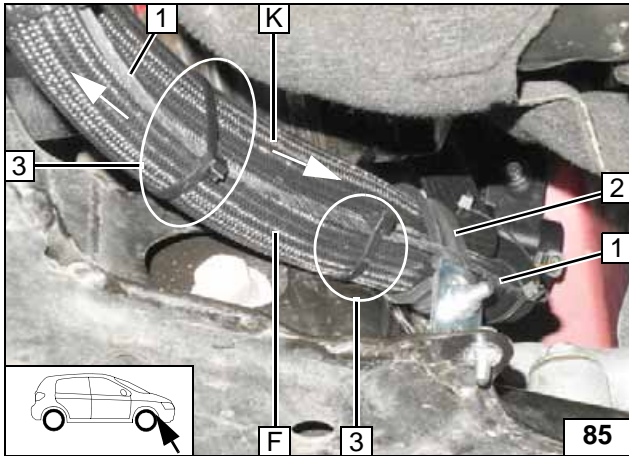

- 1 Wiring harness of circulating pump
- 2 Rubber-coated p-clamp Ø 38
- 3 Cable tie [2x]

Routing in engine compartment

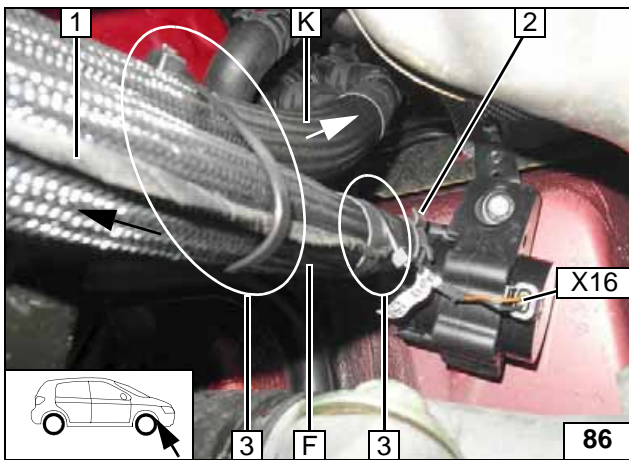

- 1 Wiring harness of circulating pump
  - 2 Spring clamp Ø 25
  - 3 Cable tie [2x]
- X16 Plug wiring harness of circulating pump mounted

Connection Circulation pump

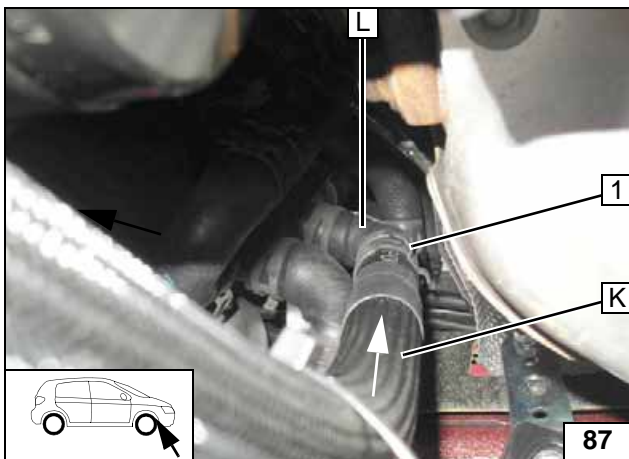

- 1 Spring clamp Ø 25

Connection check valve



# Mazda 3

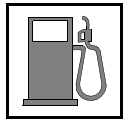

## Fuel

### CAUTION!

Open the vehicle's fuel tank cap, ventilate the tank and then re-close the tank lock.

Catch any fuel running off with an appropriate container.

Install fuel line and metering pump wiring harness so that they are protected against stone impact. Unless specified otherwise, always fasten using cable ties.

Mount the fuel line and wiring harness with rub protection on sharp edges.

### WARNING!

The fuel line and wiring harness are routed to the metering pump as shown in the wiring harness routing diagram.

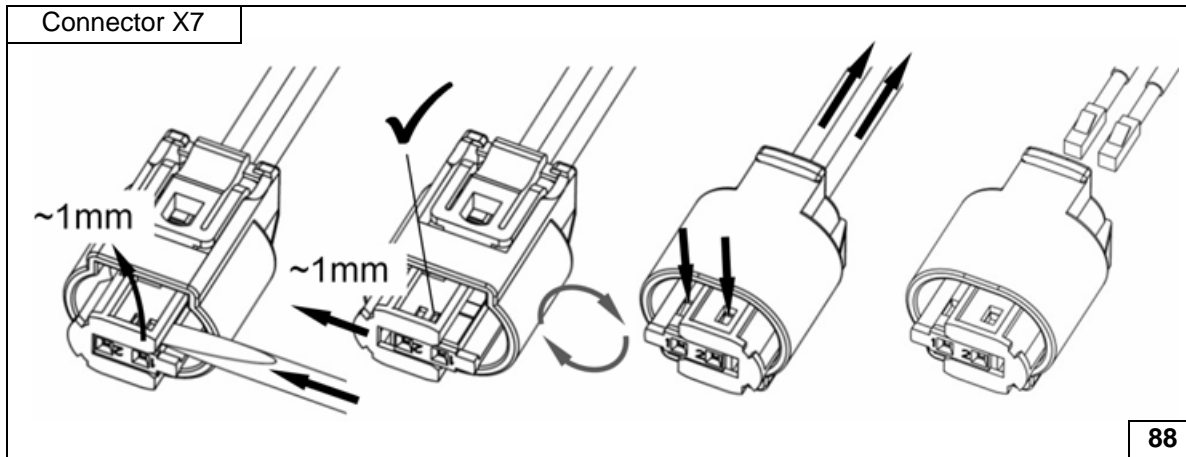

Disassembling metering pump connector

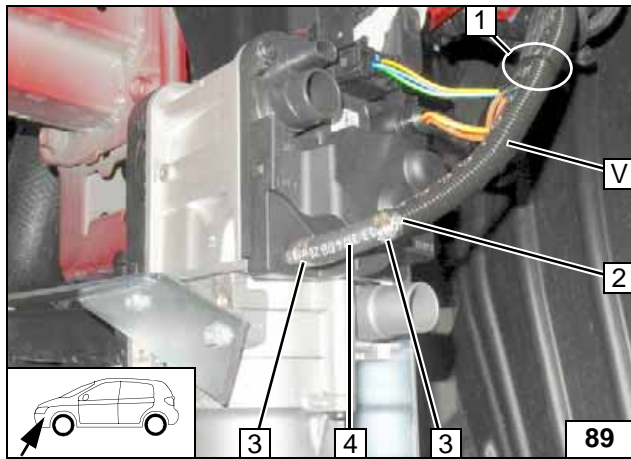

Pull fuel line 2 into corrugated tube  $\varnothing$  10 V and route to the engine compartment.

- 1 Cable tie
- 3 Clamp  $\varnothing$  10 [2x]
- 4 Hose section



Connecting the heater

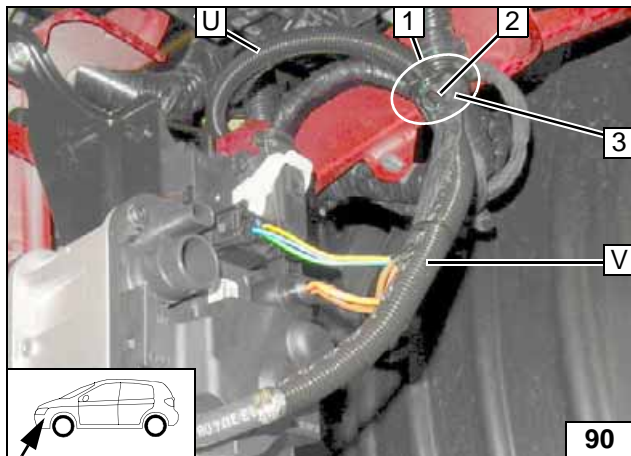
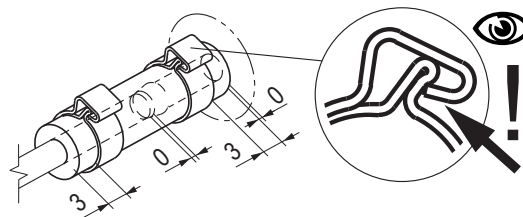

Pull fuel line 2 and wiring harness of metering pump 3 into corrugated tube  $\varnothing$  10 U and route to the engine compartment.

- 1 Cable tie



Routing lines

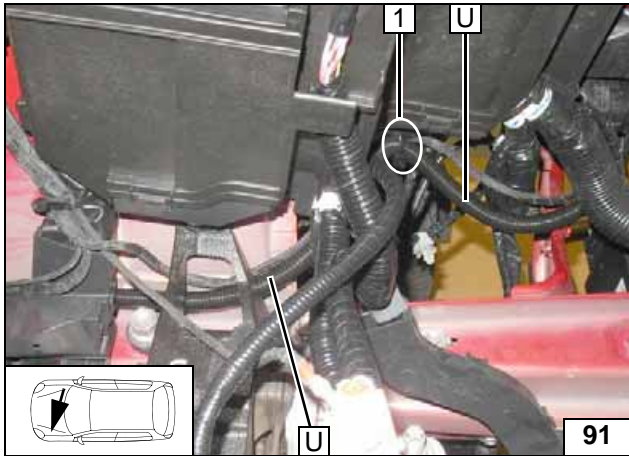
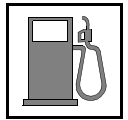

Route fuel line and wiring harness of metering pump in corrugated tube Ø 10 **U** along original vehicle wiring harness to the firewall.

1 Cable tie



Routing lines

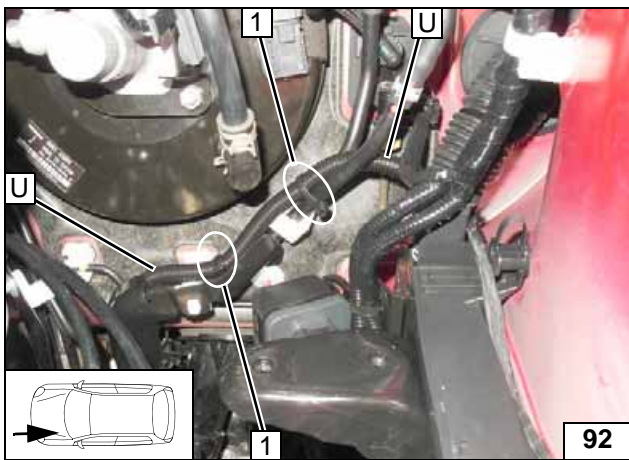

Route fuel line and wiring harness of metering pump in corrugated tube Ø 10 **U** along original vehicle fuel line to the underbody.

1 Cable tie [2x]



Routing lines

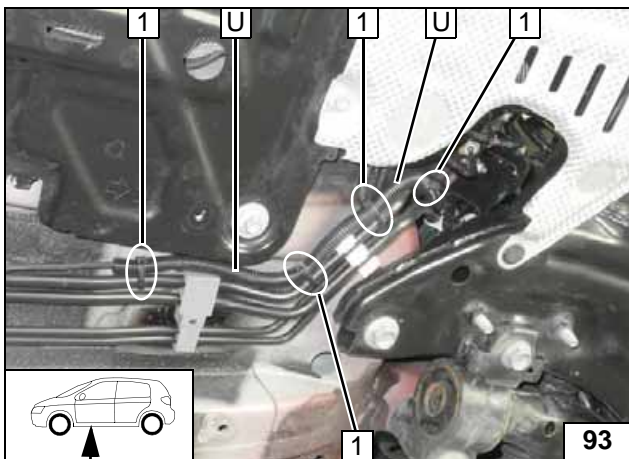

Route fuel line and wiring harness of fuel metering pump in corrugated tube Ø 10 **U** along the original vehicle fuel lines.

1 Cable tie [4x]



Routing lines

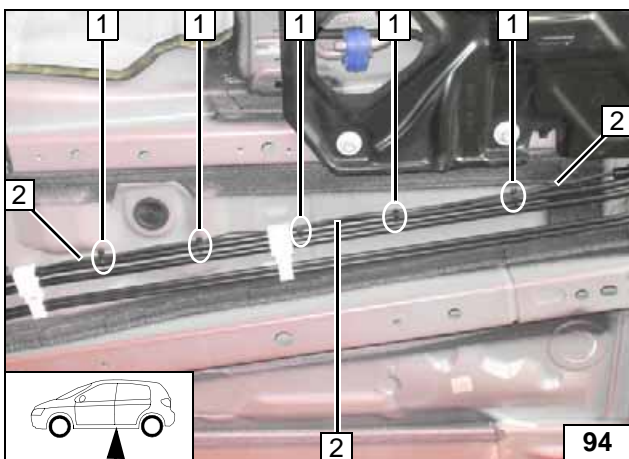

Route fuel line and wiring harness of fuel metering pump **2** along original vehicle fuel lines to the installation location of the fuel metering pump.

1 Cable tie [5x]



Routing lines

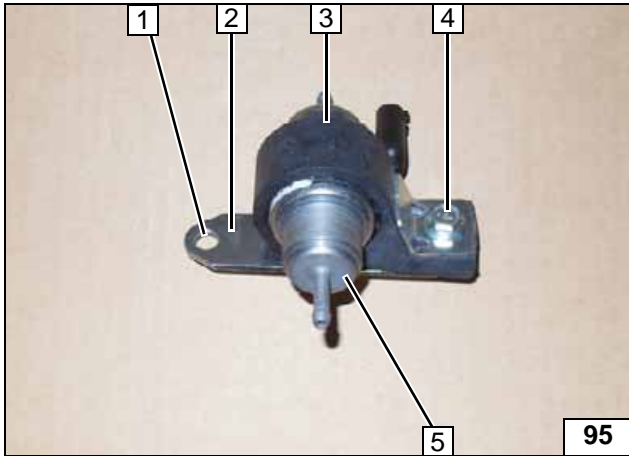
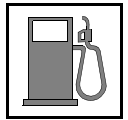

- 1 Enlarge hole Ø 8,5
- 2 Perforated bracket
- 3 Intake of metering pump
- 4 M6x25 bolt, Support angle bracket, flanged nut
- 5 Metering pump

**Premounting metering pump**

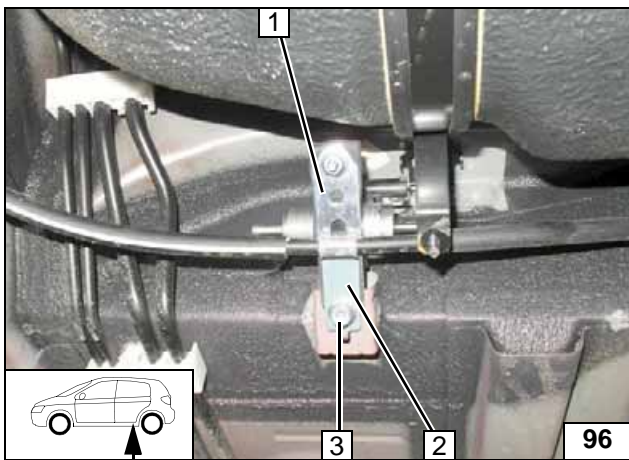

- 1 Prepared metering pump
- 2 Holder hand brake cable
- 3 Original vehicle bolt (25Nm)

**Mounting metering pump**

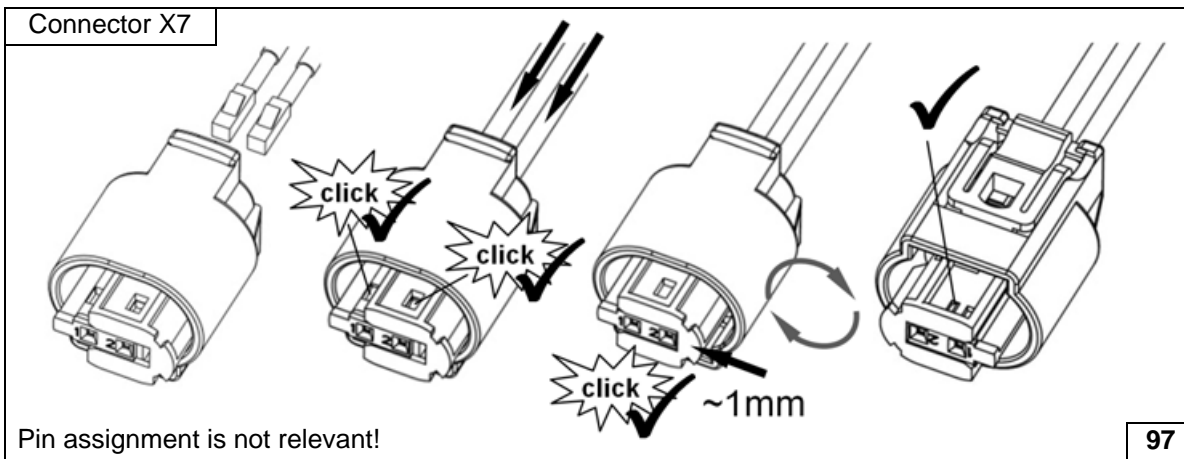

**Completing metering pump connector**

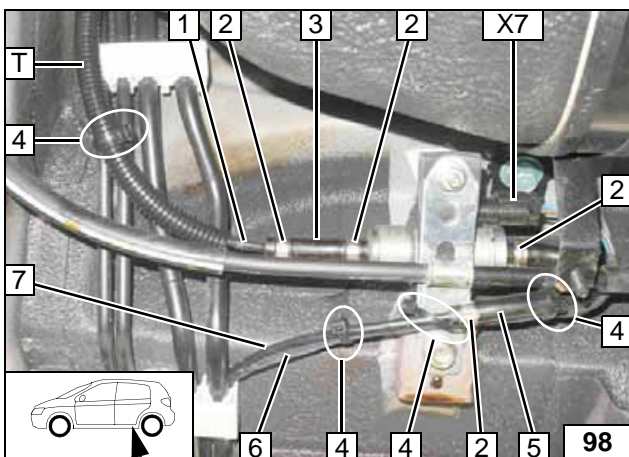

Cut the heater fuel line. Mounting fuel line, moulded hose and hose section see the following figure. Route fuel line 1 into corrugated tube Ø 10 T to the fuel-tank sending

- 2 Clamp Ø 10 [4x]
- 3 Hose section
- 4 Cable tie [4x]
- 5 180° moulded hose
- 6 Metering pump wiring harness
- 7 Heater fuel line
- X7 Connector metering pump wiring harness



**Connecting metering pump**

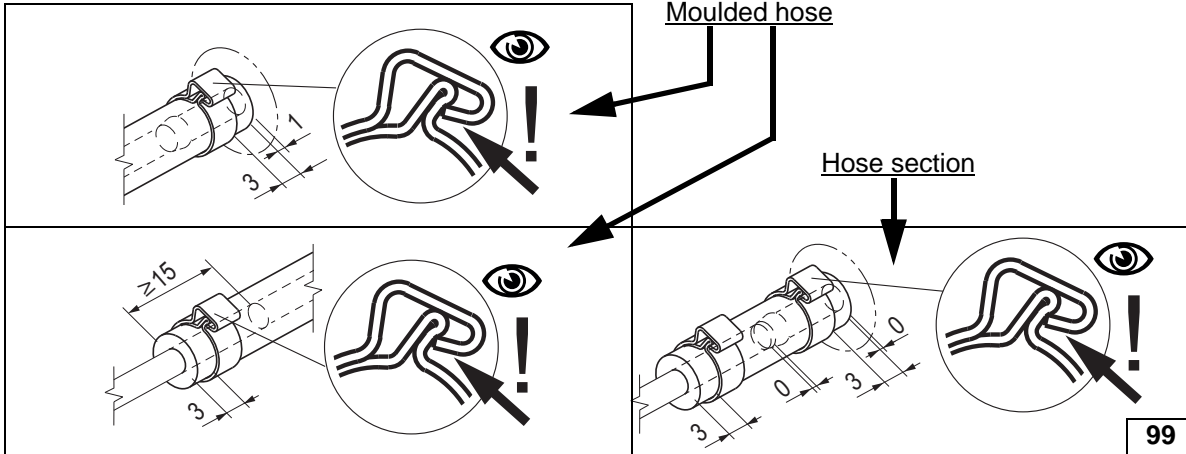
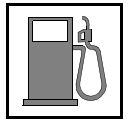

Mounting fuel line, moulded hose and hose section

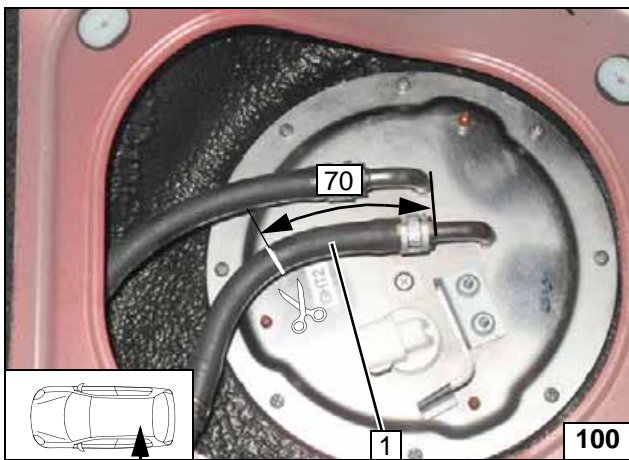

Separate fuel supply line 1 as shown.



Fuel extraction

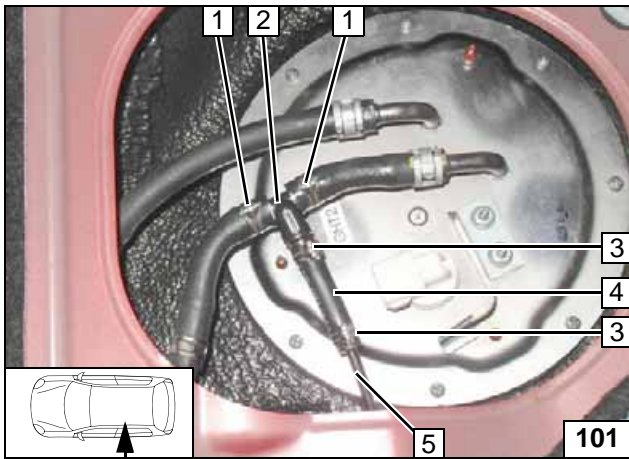

Mounting fuel line and clamps see the following figure.

- 1 Clamp Ø 13,5 [2x]
- 2 Fuel standpipe 8x5x8 (T-section)
- 3 Clamp Ø 10 [2x]
- 4 Hose section
- 5 Fuel line



Installing fuel standpipe

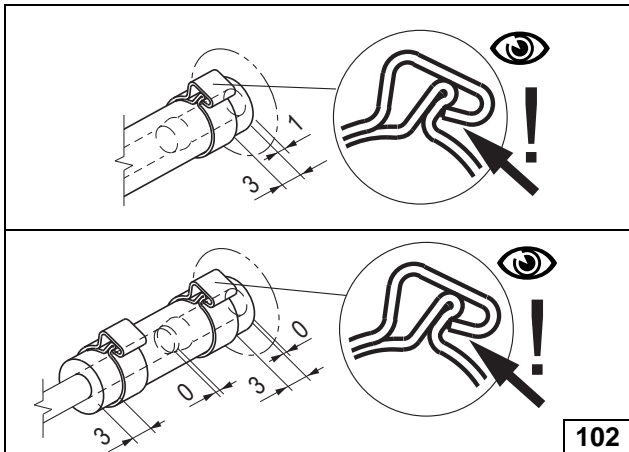

← Clamp Ø 13,5

← Clamp Ø 10

Mounting fuel line and clamp



# Mazda 3

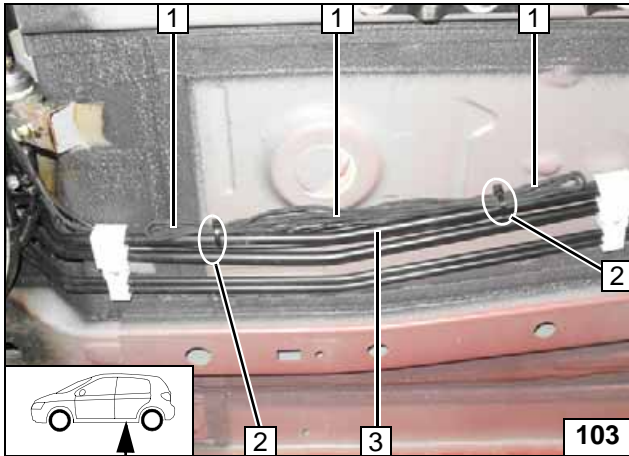
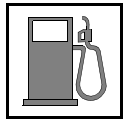

Fixation of remaining cable overlength **1** along original vehicle fuel lines **3**.

**2** Cable tie [2x]

**Routing lines**

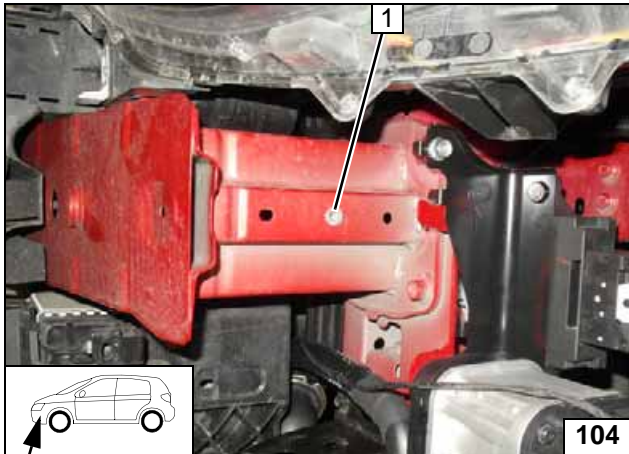
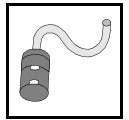

**Combustion Air**

- 1 Rivet nut, existing hole

**Installing rivet nut**

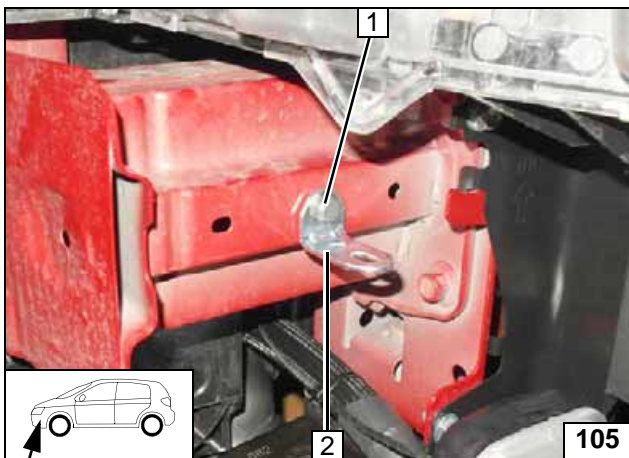

- 1 M6x20 bolt, spring lockwasher (8-10Nm)
- 2 Angle bracket

**Mounting angle bracket**

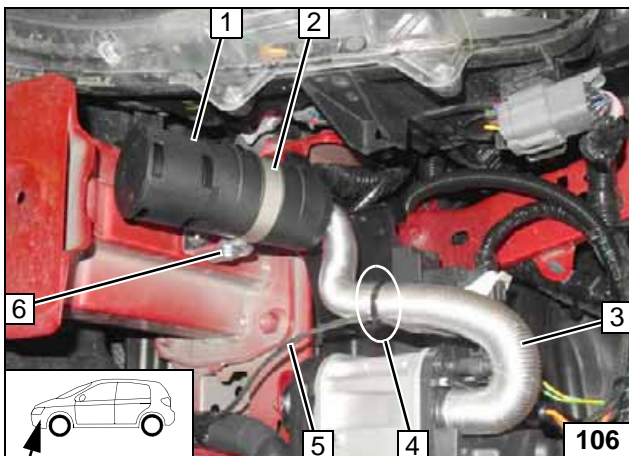

- 1 Silencer
- 2 Clamp Ø 51
- 3 Combustion air pipe
- 4 Cable tie
- 5 Wiring harness of circulating pump
- 6 M5x16 bolt, large diameter washer, flanged nut (5-6Nm)



**Mounting silencer**

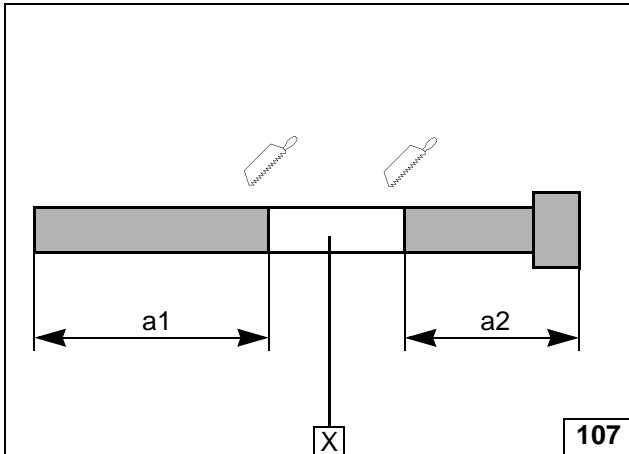
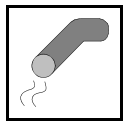

**Exhaust Gas**

a1 = 190  
a2 = 100

X =

**Preparing exhaust pipe**

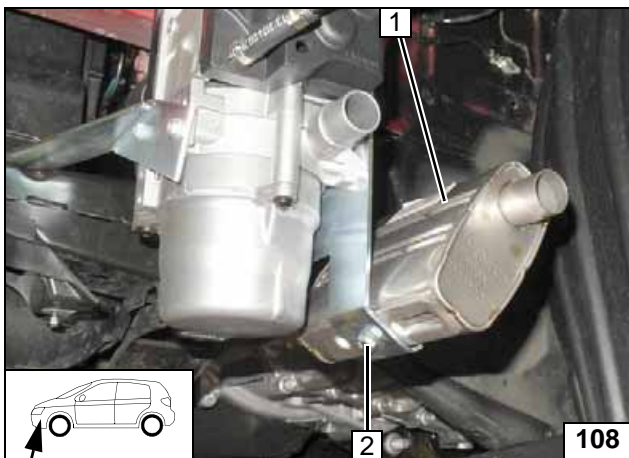

- 1 Exhaust silencer
- 2 M6x16 bolt, spring lockwasher (8-10Nm)

**Installing exhaust silencer**

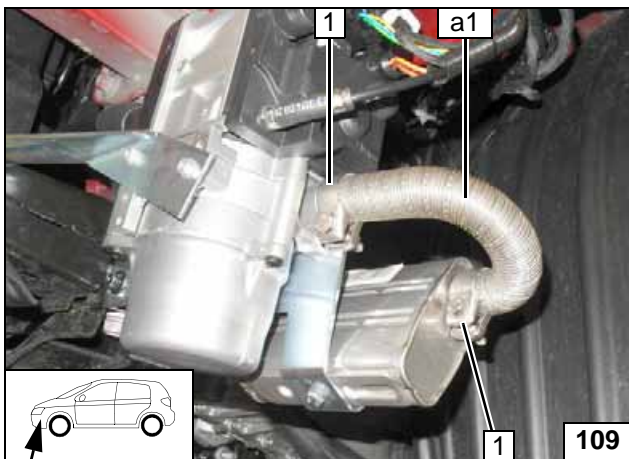

- 1 Hose clamp [2x]

**Mounting exhaust pipe a1**

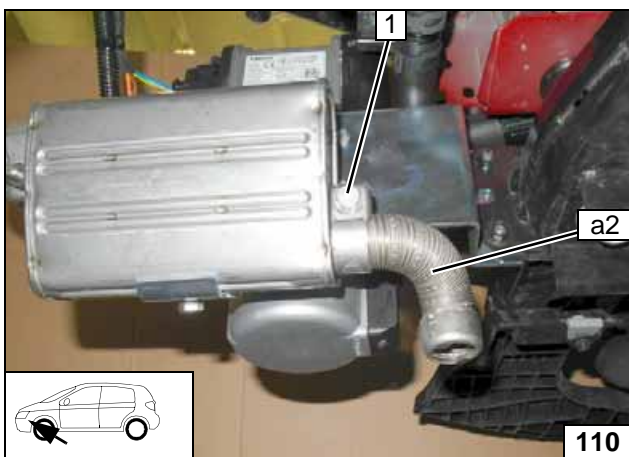

- 1 Hose clamp

**Installing exhaust pipe a2**

# Mazda 3

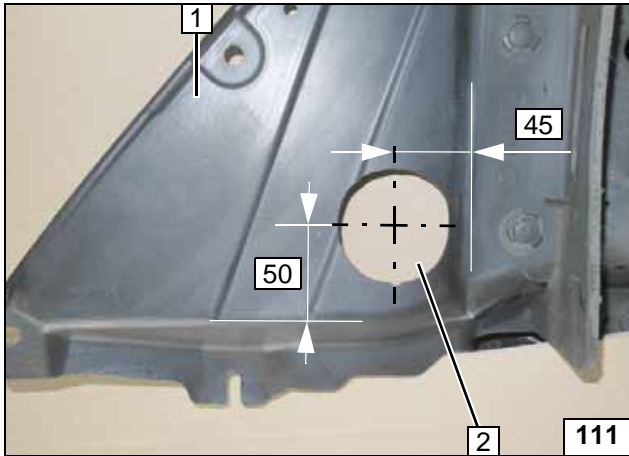
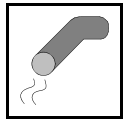

- 1 Left-hand wheel well trim
- 2 Hole  $\varnothing$  60

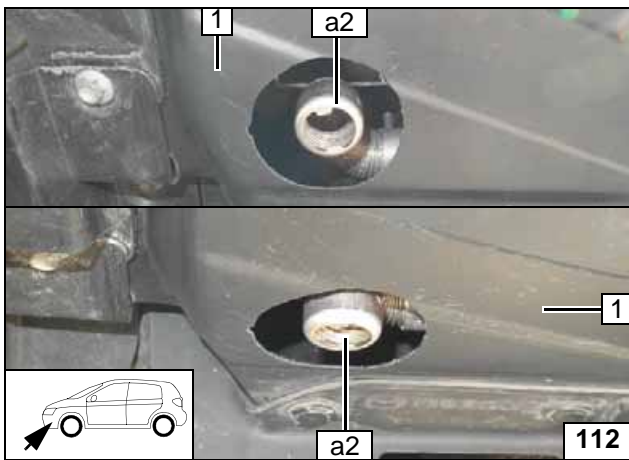

Install left-hand wheel well trim 1.  
Ensure sufficient distance around the ex-  
haust pipe a2 an wheel well trim, correct if  
necessary.

Holes in  
wheel well  
trim



Installing  
wheel well  
trim



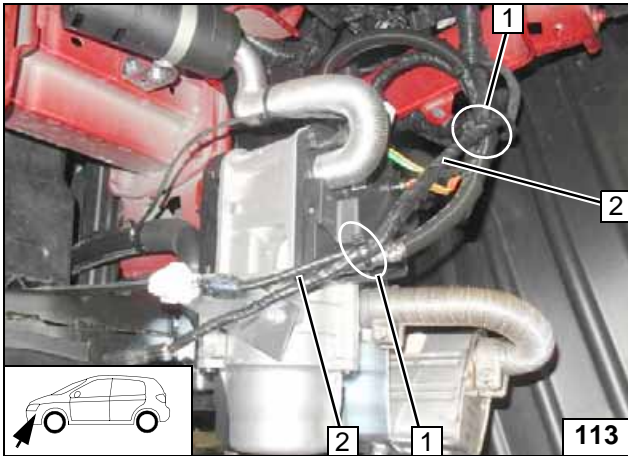
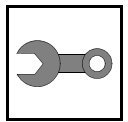

**Final Work**

- 1 Cable tie [2x]
- 2 Wiring harness of fog lights and distance warning



**Mounting wiring harness fog light and distance warning**

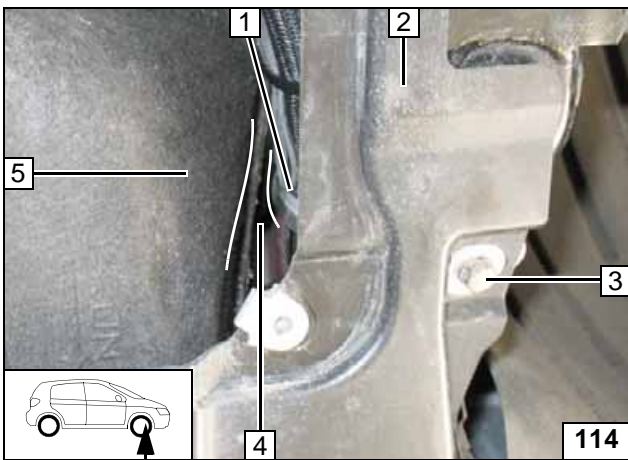

Install undercover **2**. Align to right angle bracket (premounted rubber-coated p-clamp) **1** and install M6x20 bolt, spring lockwasher and large diameter washer at position **3** (8-10Nm). Ensure sufficient distance around engine cover **5** and rubber-coated p-clamp **1** in the area **4** (at least 15mm), correct if necessary.



**Mounting undercover**

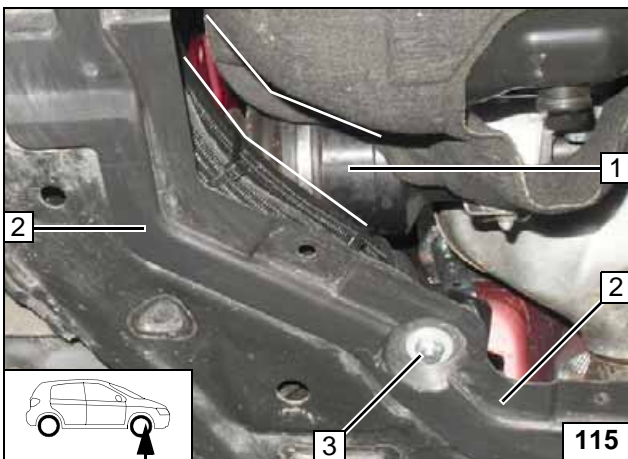

Mount M6 flanged nut and large diameter washer on M6 bolt at position **3** (8-10Nm). Ensure sufficient distance around the cover engine and hose at position **1** (at least 20mm), correct if necessary!



**Mounting undercover**

- 2 Undercover

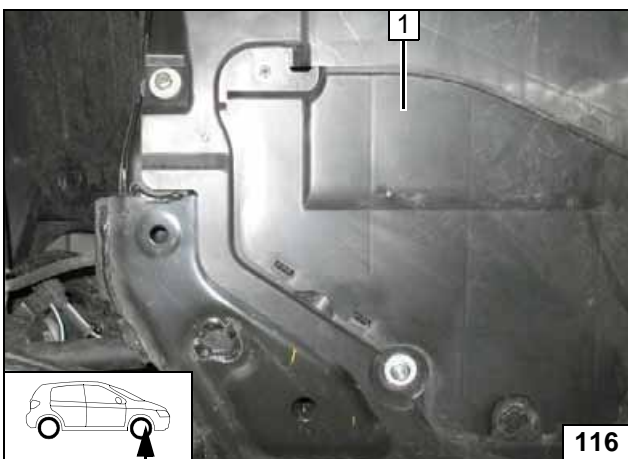

Install service flap **1**.



**Mounting service flap**

# Mazda 3

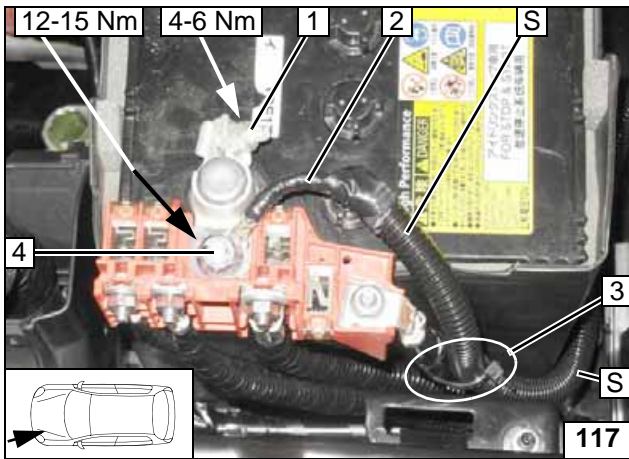

- 1 Original vehicle bolt, positive battery terminal
- 2 Positive wire R insulated, connected to positive battery terminal
- 3 Cable tie
- 4 Original vehicle nut



**Connection for positive battery terminal**

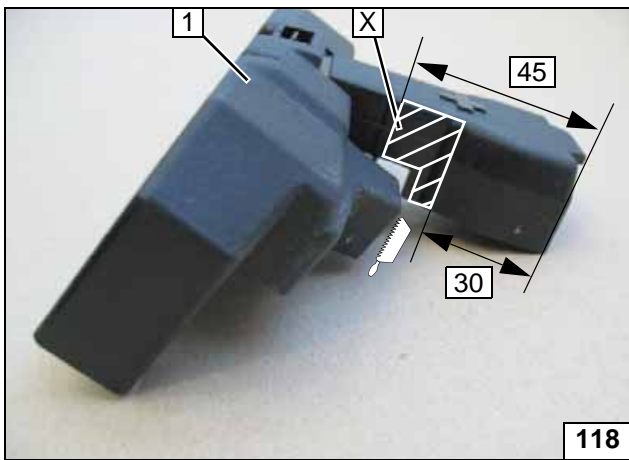

- 1 Cover positive battery terminal

X =

**Preparing Cover**

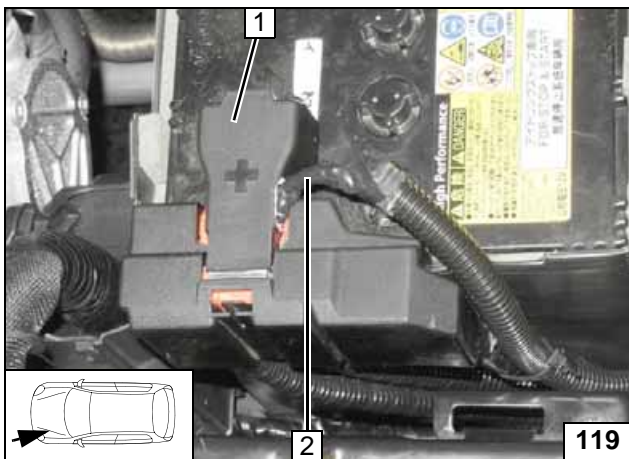

- 1 Cover positive battery terminal
- 2 Positive wire R in corrugated tube  $\varnothing$  10



**Install cover**

# Mazda 3

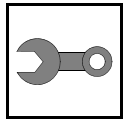

## WARNING!

Mount removed parts in reverse order by referring to MESI. Check all hoses, clamps and all electrical connections for firm seating. Insulate and tie back all loose wires. Only use manufacturer-approved coolant.



Spray heater components with anti-corrosion wax (MAZDA Underbody Protection Wax).

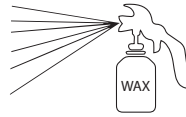

- Only install instrument panel trim after checking the PWM GW value.
- Connect battery, carrying out/following the prescribed measures in accordance with MESI "BATTERY REMOVAL/INSTALLATION [SKYACTIV- D 2.2]".
- Fill and bleed the coolant circuit according to the vehicle manufacturer's specifications.
- Adjust digital timer, teach telestart remote option
- Make settings on A/C control unit according to the „Operating Instructions for End Customer“.

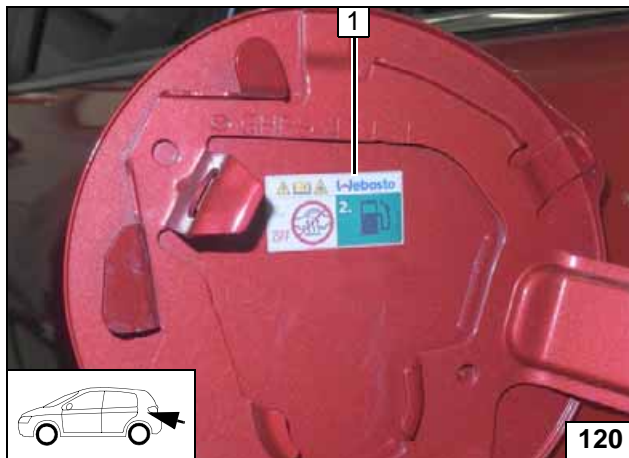

Place the caution label „Switch off parking heater before re-fuelling“ 1 in the area of the filler neck.

Place caution label

- For initial startup and function test, see installation instructions
- Check the voltage at the Blower motor in parking heating mode (see settings for the end customer). Target value 4,0 - 5,5V (corresponds approximately to level 3 when driving)!

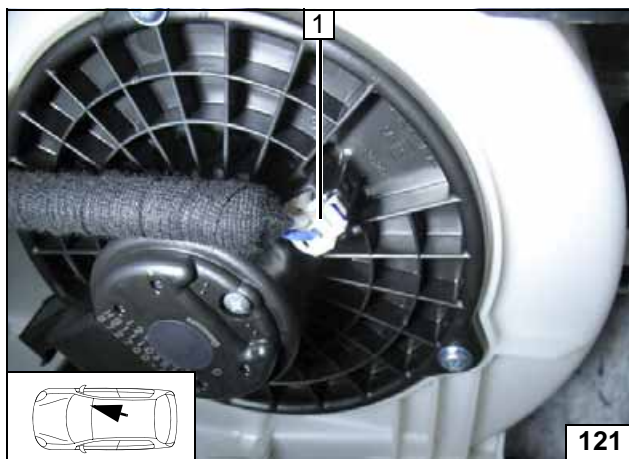

Measure voltage between both pins.

1 2-pin connector of Blower motor

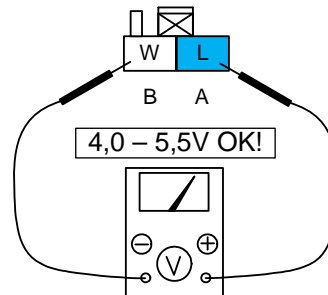

Measure voltage at Blower motor

- Only in case of deviation from the nominal value: Change the PWM GW duty cycle value using the Webasto diagnosis in 2% increments (see following section).



Webasto Thermo & Comfort SE  
 Postfach 1410  
 82199 Gilching  
 Germany  
 Internet: www.webasto.com  
 Technical Extranet:  
 http://dealers.webasto.com  
 hotline.gcs@webasto.com

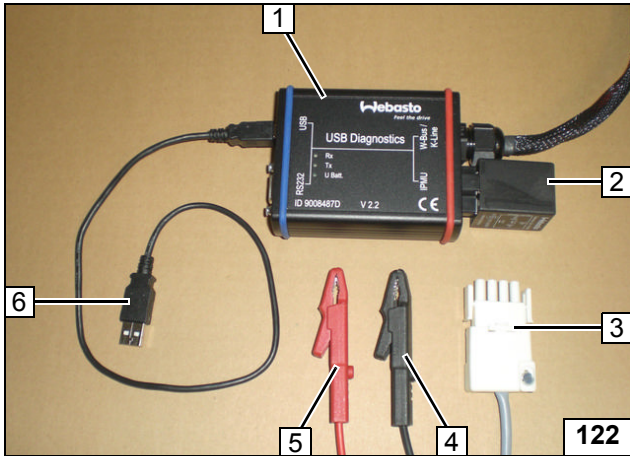
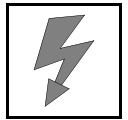

### Readjustment blower speed

Thermo Test Diagnostics,  
Mazda Order No.: 4100-77-725  
(Software version V3.1 or higher);  
free update from [www.dealers.webasto.com](http://www.dealers.webasto.com);  
support via [hotline.gcs@webasto.com](mailto:hotline.gcs@webasto.com)

- 1 Diagnostics box
- 2 PWM GW
- 3 White (ws) connector is not required
- 4 Connection for positive battery terminal
- 5 Connection for negative battery terminal
- 6 USB connection for PC



**Thermo Test Diagnostics**

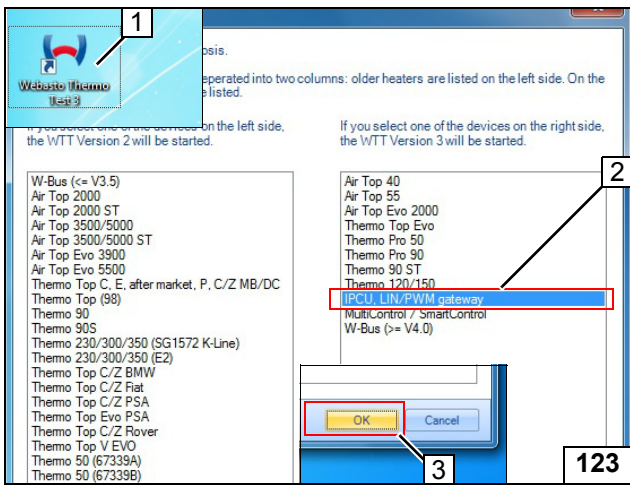

Establish all connections.  
Start up the Webasto Thermo Test 1.

2. Select "IPC.U. LIN/PWM gateway"
- 3 Click "OK" to confirm.



**Selecting PWM GW**

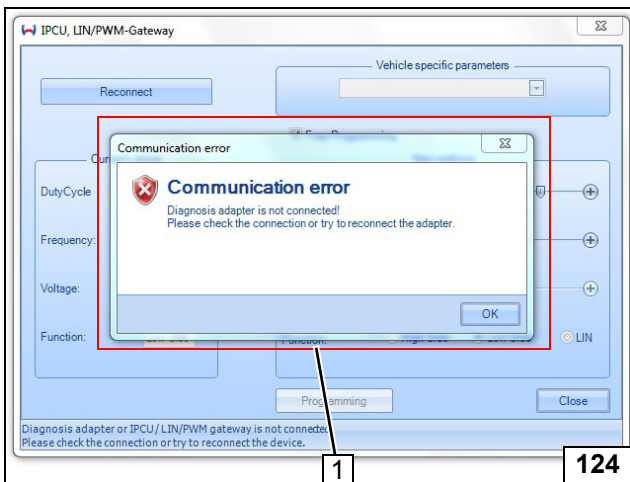

If the „Communication error“ 1 fault message appears, briefly interrupt the power supply to the diagnosis adapter and re-start PWM GW programming.



**Fault message**

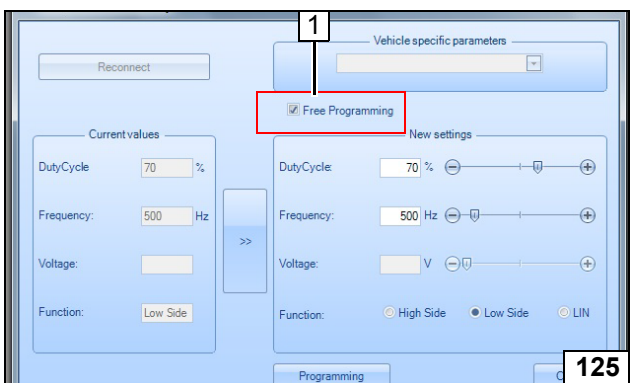

1. Activate "Free Programming"

**Select "Free Programming"**

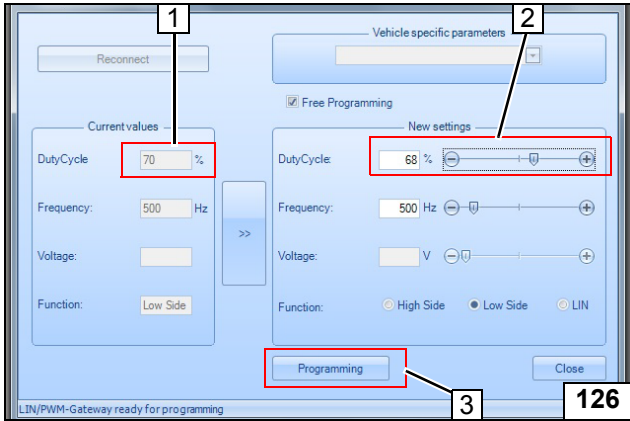
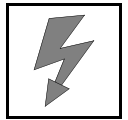

Current settings are displayed on the left. Change duty cycle in 2% increments. Enter new duty cycle on the right:

- 2% for a speed increase
- + 2% for a reduction in speed

Do not change the presettings for frequency and function!

1. Duty cycle 70% preset
2. Duty cycle 68% selected
3. Click "Programming"



Selecting the duty cycle

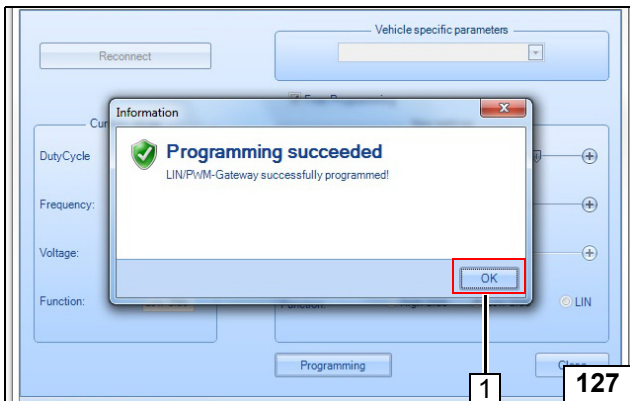

- 1 Click „OK“ to confirm.

Programming PWM GW

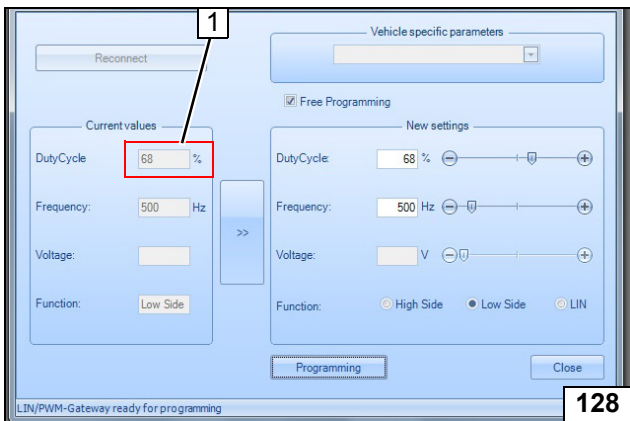

Start PWM GW diagnosis again. The new settings 1 are displayed on the left. Install PWM GW and check the voltage (target value 4,0 - 5,5V) across the connector of the Blower motor again. In case of deviations, carry out further adjustments.



Checking settings

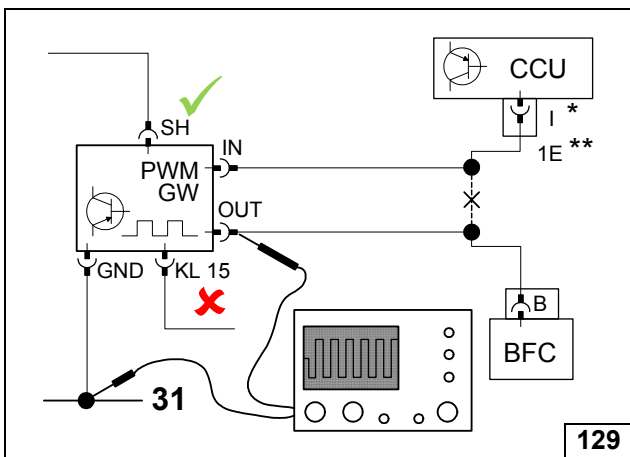

**Condition:**

- Parking heater: **ON**
- Coolant temperature: **> 55 °C**
- Ignition: **OFF**

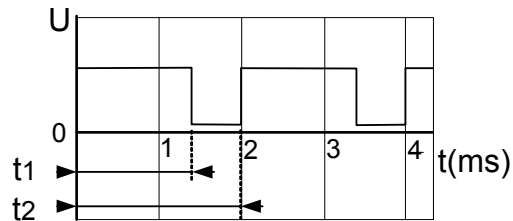

Duty Cycle =  $t1 / t2 \times 100 = 70\%$  (or readjusted value)  
 Frequency =  $1 / t2 = 500 \text{ Hz}$

Checking function with oscilloscope

## Operating Instructions for manual A/C (7-speed)

Please remove page and add to the vehicle operating instructions.

The heater operates independently from the engine in conjunction with the heating / ventilation system and can be used stationary or while driving.

The heater system is operated with fuel from the vehicle tank. This can lead to a deviation in fuel level and remaining distance displayed in the instrument cluster before and after heater operation.

To protect the vehicle battery, the heater system should not be used repeatedly without driving the vehicle in between.

**Note:**

We recommend matching the heating time to the driving time.

Heating time = driving time

**Example:**

For a driving time of approx. 20 minutes, we recommend not to exceed the heating time of 20 minutes.

**Note on i-stop:**

The i-stop function does not operate when the battery power is depleted. The length of time required before i-stop functions again could be longer after heater operation.

This is no malfunction and the system works as designed.

Depending on vehicle use it might be necessary to recharge the vehicle battery from time to time.

Before parking the vehicle, make the following settings:

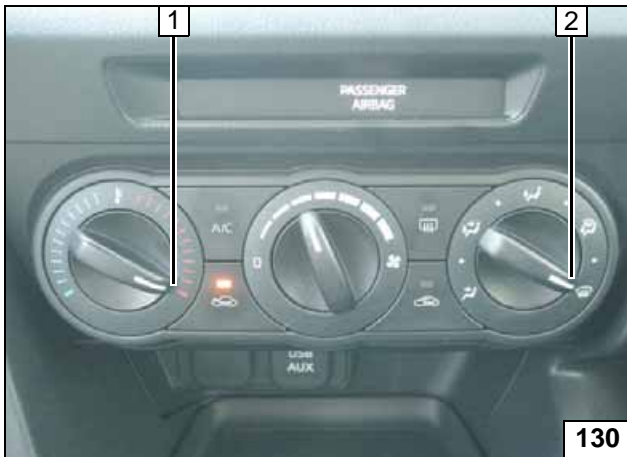

- 1 Set temperature to „max.“
- 2 Air outlet to windscreen

AC control unit

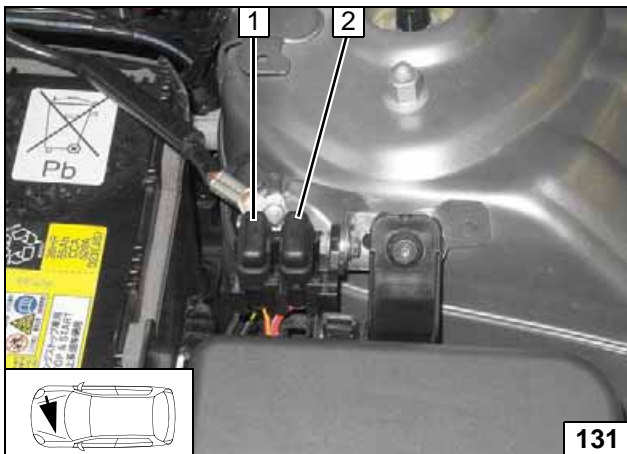

- 1 30A main fuse F2 of passenger compartment
- 2 20A heater fuse F1

Fuses of engine compartment



## Mazda 3

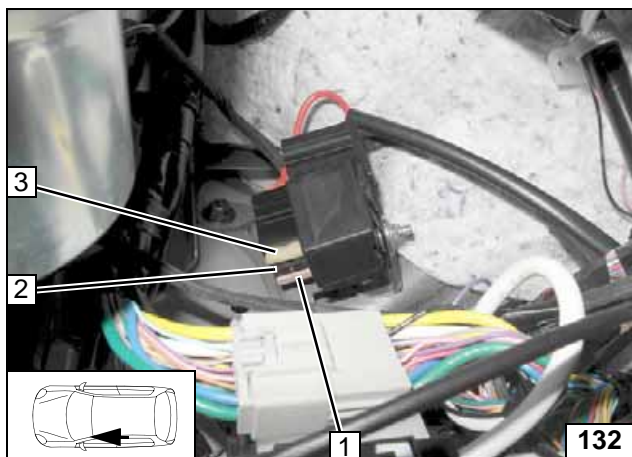

- 1 3A fuse F5 of blower control
- 2 1A fuse F3 of heater control
- 3 25A fuse F4 of blower motor

Fuses of  
passenger  
compartment

## Operating Instructions for auto A/C (Dual type)

Please remove page and add to the vehicle operating instructions.

The heater operates independently from the engine in conjunction with the heating / ventilation system and can be used stationary or while driving.

The heater system is operated with fuel from the vehicle tank. This can lead to a deviation in fuel level and remaining distance displayed in the instrument cluster before and after heater operation.

To protect the vehicle battery, the heater system should not be used repeatedly without driving the vehicle in between.

**Note:**

We recommend matching the heating time to the driving time.

Heating time = driving time

**Example:**

For a driving time of approx. 20 minutes, we recommend not to exceed the heating time of 20 minutes.

**Note on i-stop:**

The i-stop function does not operate when the battery power is depleted. The length of time required before i-stop functions again could be longer after heater operation.

This is no malfunction and the system works as designed.

Depending on vehicle use it might be necessary to recharge the vehicle battery from time to time.

Before parking the vehicle, make the following settings:



- 1 Set temperature on both sides to „max.“
- 2 Air outlet to windscreen

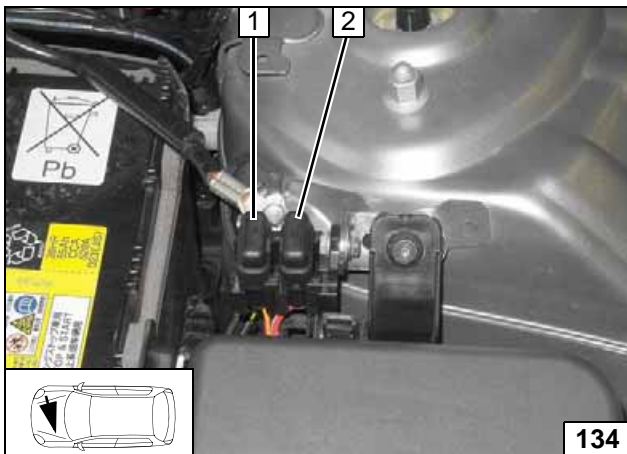

- 1 30A main fuse F2 of passenger compartment
- 2 20A heater fuse F1



AAC control unit

Fuses of engine compartment





## Mazda 3

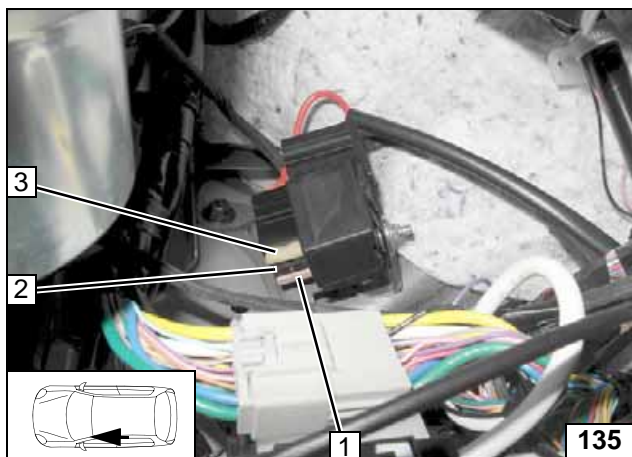

- 1 3A fuse F5 of blower control
- 2 1A fuse F3 of heater control
- 3 25A fuse F4 of blower motor

Fuses of  
passenger  
compartment