

Water Heater

Thermo Top Evo 4 Parking Heater



Installation Documentation

Fiat 500L

Validity

Manufacturer	Model	Type	EG-BE No./ ABE
Fiat	500L	312	e3 * 2001 / 116 * 0217 * ...

Motorisation	Fuel	Transmission type	Output in kW	Displacement in cm ³	Engine code
1.4 T-Jet	Petrol	6-speed SG	88	1368	940B7000

SG = manual transmission

From Model Year 2014

Left-hand drive vehicle

Verified equipment variants: Manual / automatic air-conditioning system
 Front fog lights / Daytime running lights
 Start / Stop
 Headlight washer system

Not verified: Passenger compartment monitoring

Total installation time: approx. 7.5 hours

Fiat 500L

Table of Contents

Validity	1	Preparing Installation Location	17
Necessary Components	2	Preparing Heater	19
Installation Overview	2	Installing Heater	21
Information on Total Installation Time	2	Fuel	22
Information on Operating and Installation Instructions	3	Coolant Circuit	26
Information on Validity	4	Exhaust Gas	31
Technical Information	4	Final Work	33
Explanatory Notes on Document	4	Template for Fuel Standpipe	34
Preliminary Work	5	Operating Instructions for Manual Air-Conditioning	35
Heater Installation Location	5	Operating Instructions for Automatic Air-Conditioning	36
Preparing Electrical System	6		
Electrical System	9		
Fan Controller for Manual Air-Conditioning	10		
Fan Controller for Automatic Air-Conditioning	12		
MultiControl CAR Option	15		
Remote Option (Telestart)	15		
Remote Option (Thermo Call)	16		

Necessary Components

- Basic delivery scope of *Thermo Top Evo 4* based on price list
- Installation kit for Fiat 500L 2014 Petrol: **1320779D**
- Required additionally for automatic air-conditioning: Automatic air-conditioning kit **1320864B**
- Heater control in accordance with price list and upon consultation with end customer
- In case of Telestart, indicator lamp in accordance with price list and in consultation with end customer

Installation instructions:

- Arrange for the vehicle to be delivered with the tank only about ¼ full.
- The installation location of the push button for Telestart or Thermo Call must be agreed with the end customer.
- Depending on the available space and manufacturer's instructions, we recommend the use of a vehicle battery with more electrical capacity.
- When installing a parking heater only the Thermo Top Evo 4 should be built in.
The heater will be integrated into the "island" coolant circuit and is used to heat up the passenger compartment.
The engine is not pre-heated.

Installation Overview

Legend:

1. Heater
2. Engine compartment fuse holder
3. Passenger compartment relay and fuse holder
4. PWM GW (only in case of automatic air-conditioning)
5. Circulating pump
6. MultiControl CAR
7. Metering pump

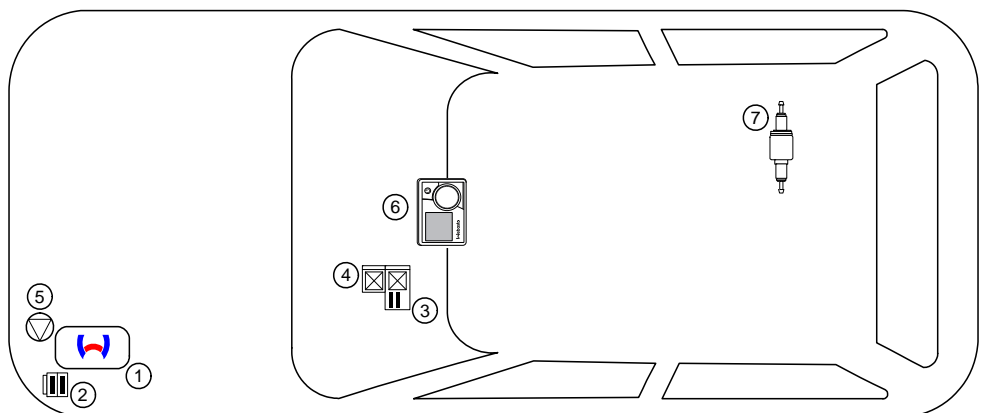

Information on Total Installation Time

The total installation time includes the time needed for mounting and demounting of the vehicle-specific components, the heater specific installation time and all other times required for the system integration and initial start-up of the heater.

The total installation time may vary for vehicle equipment other than provided.

Information on Operating and Installation Instructions

1 Important notes (not complete)

1.1 Installation and Repair



The improper installation or repairing of Webasto heating and cooling systems can cause fire or the leakage of deadly carbon monoxide, leading to serious injury or death.



To install and repair Webasto heating and cooling systems you need to have completed a special company training course and have the appropriate technical documentation, special tools and special equipment.



Installation and repair may ONLY be carried out by persons trained and certified in a Webasto training course. NEVER try to install or repair Webasto heating or cooling systems if you have not completed a Webasto training course, you do not have the necessary technical skills and you do not have the technical documentation, tools and equipment available to ensure that you can complete the installation and repair work properly.

Only use genuine Webasto parts. See the Webasto air and water heaters accessories catalogue for this purpose.

1.2 Operation

To ensure safe operation, we recommend having the heater checked every two years by an authorised Webasto dealer, especially when used over a long period and/or under extreme environmental conditions.

Do not operate the heater in closed rooms due to the danger of poisoning and suffocation.

Always switch off the heater before refuelling.

The heater may only be used with the prescribed fuel diesel (DIN EN 590) or petrol (DIN EN 228).

The heater may not be cleaned with a high-pressure cleaner.

1.3 Please note

ALWAYS follow all Webasto installation and operating instructions and observe all warnings.

To become familiar with and understand all functions and properties of the heater, the operating instructions must be read carefully and observed at all times.

For proper, safe installation and repair work, the installation instructions with all warnings and safety information must be carefully read and observed at all times. Please always contact a workshop authorised by Webasto for all installation and repair work.

Important

Webasto shall assume no liability for defects, damage and injuries resulting from a failure to observe the installation, repair and operating instructions of the information contained in them.

This liability exclusion particularly applies to improper installations and repairs, installations and repairs by untrained persons or in the case of a failure to use genuine spare parts.

The liability due to culpable disregard to life, limb or health and due to damage or injuries caused by a wilful or reckless breach of duty remain unaffected, as does the obligatory product liability.

Installation should be carried out according to the general, standard rules of technology. Unless specified otherwise, fasten hoses, lines and wiring harnesses to original vehicle lines and wiring harnesses using cable ties. Insulate loose wire ends and tie back. Connectors on electronic components must audibly snap into place during assembly.

Sharp edges should be fitted with rub protection. Spray unfinished body areas, e.g. drilled holes, with anti-corrosion wax (Tectyl 100K, Order No. 111329).

Observe the instructions and guidelines of the respective vehicle manufacturer for demounting and mounting vehicle specific components!

The initial startup is to be executed with the Webasto Thermo Test Diagnosis.

When installing a programmable control module (e.g. a PWM Gateway), the corresponding settings must be checked or adjusted.

2 Statutory regulations governing installation

Guidelines	TT-Evo
Heating Directive ECE R122	E1 00 0258
EMC Directive ECE R10	E1 04 5627

Note

The regulations of these guidelines are binding in the scope of the Directive 70/156/EEC and/or 2007/46/EC (for new vehicle models from 29/04/2009) and should also be observed in countries in which there are no special regulations.

Important

Failure to follow the installation instructions will result in the invalidation of the type approval for the heater and therefore invalidation of the general **homologation of the vehicle**.

Note

The heater is licensed in accordance with paragraph 19, section 3, No. 2b of the StVZO (German Road Traffic Licensing Authority).

2.1 Excerpt from the directive 122 (heater) section 5 for the installation of the heater.

Beginning of excerpt.

ANNEX VII

REQUIREMENTS FOR COMBUSTION HEATERS AND THEIR INSTALLATION

1. GENERAL REQUIREMENTS

1.7.1. A clearly visible tell-tale in the operator's field of view shall inform when the combustion heater is switched on or off.

2. VEHICLE INSTALLATION REQUIREMENTS

2.1. Scope

2.1.1. Subject to paragraph 2.1.2. combustion heaters shall be installed according to the requirements of this Annex.

2.1.2. Vehicles of category O having liquid fuel heaters are deemed to comply with the requirements of this Annex.

2.2. Positioning of heater

2.2.1. Body sections and any other components in the vicinity of the heater must be protected from excessive heat and the possibility of fuel or oil contamination.

2.2.2. The combustion heater shall not constitute a risk of fire, even in the case of overheating. This requirement shall be deemed to be fulfilled if the installation ensures an adequate distance to all parts and suitable ventilation, by the use of fire resistant materials or by the use of heat shields.

2.2.3. In the case of M2 and M3 vehicles, the heater must not be positioned in the passenger compartment. However, an installation in an effectively sealed envelope which also complies with the conditions in paragraph 2.2.2 may be used.

2.2.4. The label referred to in paragraph 1.4 or a duplicate, must be positioned so that it can be easily read when the heater is installed in the vehicle.

2.2.5. Every reasonable precaution should be taken in positioning the heater to minimise the risk of injury and damage to personal property.

2.3. Fuel supply

2.3.1. The fuel filler must not be situated in the passenger compartment and must be provided with an effective cap to prevent fuel spillage

2.3.2. In the case of liquid fuel heaters, where a supply separate to that of the vehicle is provided, the type of fuel and its filler point must be clearly labelled

2.3.3. A notice, indicating that the heater must be shut down before refuelling, must be affixed to the fuelling point. In addition a suitable instruction must be included in the manufacturer's operating manual.

2.4. Exhaust system

2.4.1. The exhaust gas outlet must be located so as to prevent emissions from entering the vehicle through ventilators, heated air inlets or opening windows.

2.5. Combustion air inlet

2.5.1. The air for the combustion chamber of the heater must not be drawn from the passenger compartment of the vehicle.

2.5.2. The air inlet must be so positioned or guarded that blocking by rubbish or luggage is unlikely.

2.6. Heating air inlet

2.6.1. The heating air supply may be fresh or recirculated air and must be drawn from a clean area not likely to be contaminated by exhaust fumes emitted either by the propulsion engine, the combustion heater or any other vehicle source.

2.6.2. The inlet duct must be protected by mesh or other suitable means.

2.7. Heating air outlet

2.7.1. Any ducting used to route the hot air through the vehicle must be so positioned or protected that no injury or damage could be caused if it were to be touched.

2.7.2. The air outlet must be so positioned or guarded that blocking by rubbish or luggage is unlikely.

End of excerpt.

In multilingual versions the German language is binding.

Information on Validity

This installation documentation applies to Fiat 500L Petrol vehicles - for validity, see page 1 - from model year 2014 and later, assuming technical modifications to the vehicle do not affect installation, any liability claims excluded. Depending on the vehicle version and equipment, modifications may be necessary during installation with respect to this installation documentation.

Vehicle and engine types, equipment variants and other specifications not listed in this installation documentation have not been tested. However, installation according to this installation documentation may be possible.

Technical Information

Special tools

- Hose clamp pliers for self-clamping hose clamps
- Hose clamp pliers for Clic hose clamps of type W
- Automatic wire stripper 0.2 - 6mm²
- Crimping pliers for cable lug / tab connector 0.5 - 6mm²
- Torque wrench for 2.0 - 10 Nm
- Hose clamping pliers
- Metric thread-setter kit
- Webasto Thermo Test Diagnosis with current software

Dimensions

- All dimensions are in mm

Tightening torque values

- Tightening torque values of 5x13 heater bolts and 5x11 heater stud bolts = 8 Nm.
- Tightening torque values of 5x15 bolts for retaining plate of water connection piece = 7Nm.
- Tighten other bolt connections in accordance with manufacturer's instructions or in accordance with state-of-the-art-technology.

Explanatory Notes on Document

You will find an identification mark on the outside top right corner of the page in question to provide you with a quick overview of the individual working steps.

Special features are highlighted using the following symbols:

Mechanical system



Electrical system



Coolant circuit

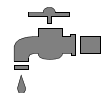

Combustion air

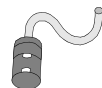

Fuel



Exhaust gas



Software



Specific risk of injury or fatal accidents.



Specific risk due to electrical voltage.



Specific risk of damage to components.



Specific risk of fire or explosion.



Reference to general installation instructions of the Webasto components or to the manufacturer's vehicle-specific documents



Reference to a special technical feature.



The arrow in the vehicle icon indicates the position on the vehicle and the viewing angle

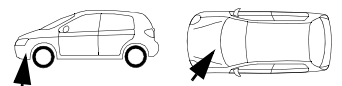

Tightening torque according to the manufacturer's vehicle-specific documents



Fiat 500L

Preliminary Work

Vehicle

- Open the fuel tank cap.
- Ventilate the fuel tank.
- Close the fuel tank cap again.
- Depressurise the cooling system.
- Remove the upper engine cover.
- Disconnect the battery and remove it with the battery carrier.
- Remove the windscreen wiper arms on the left and right.
- Remove the cowl panel.
- Remove the wiper motor with linkage.
- Fold back the backrest of the rear bench seat, completely fold back the bench seat.
- Remove the trim below the bench seat (4x plastic clip).
- Remove the lower engine cover/underride protection.
- Remove the trim of the fuel lines on the underbody.
- Remove the footwell trim below the glove compartment.
- Remove the cover of the fan controller in the footwell on the front passenger's side (only in case of automatic air-conditioning).
- Remove the lateral cover of the centre console.
- Remove the cover/access to the driver's side fuse box.
- Remove the lower cover of the instrument panel trim on the left (bolted 2x).

The following work should only be performed during the corresponding installation sequence:

- Remove the tank-fitting service lid.
- Remove the fuel-tank sending unit in accordance with the manufacturer's instructions.

Heater

- Remove years that do not apply from the type and duplicate label.
- Attach the duplicate label (type label) in the appropriate place in the engine compartment.

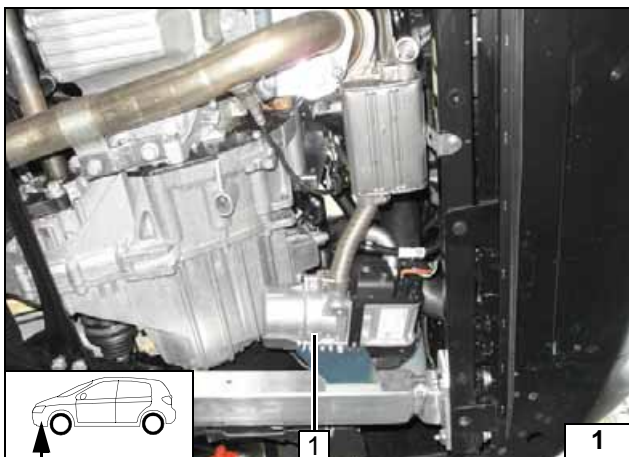

Heater Installation Location

- 1 Heater

Installation location

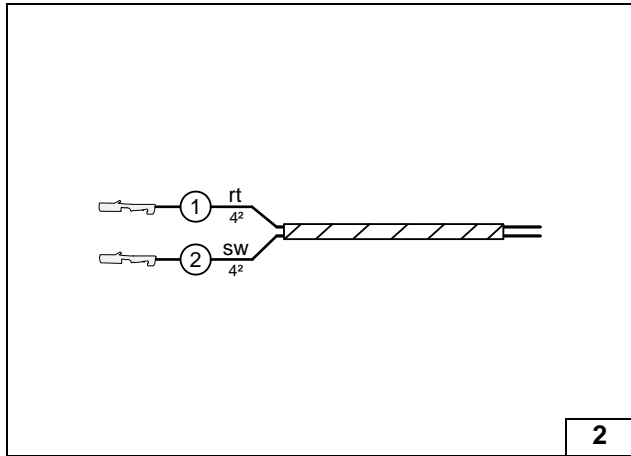
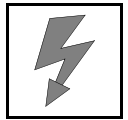

Preparing Electrical System

Wire sections retain their numbering throughout the whole document.

Produce all following electrical connections as shown in the wiring diagram.

Manual air-conditioning

- ① Red (rt) wire of fan wiring harness
- ② Black (sw) wire of fan wiring harness



Assigning wires

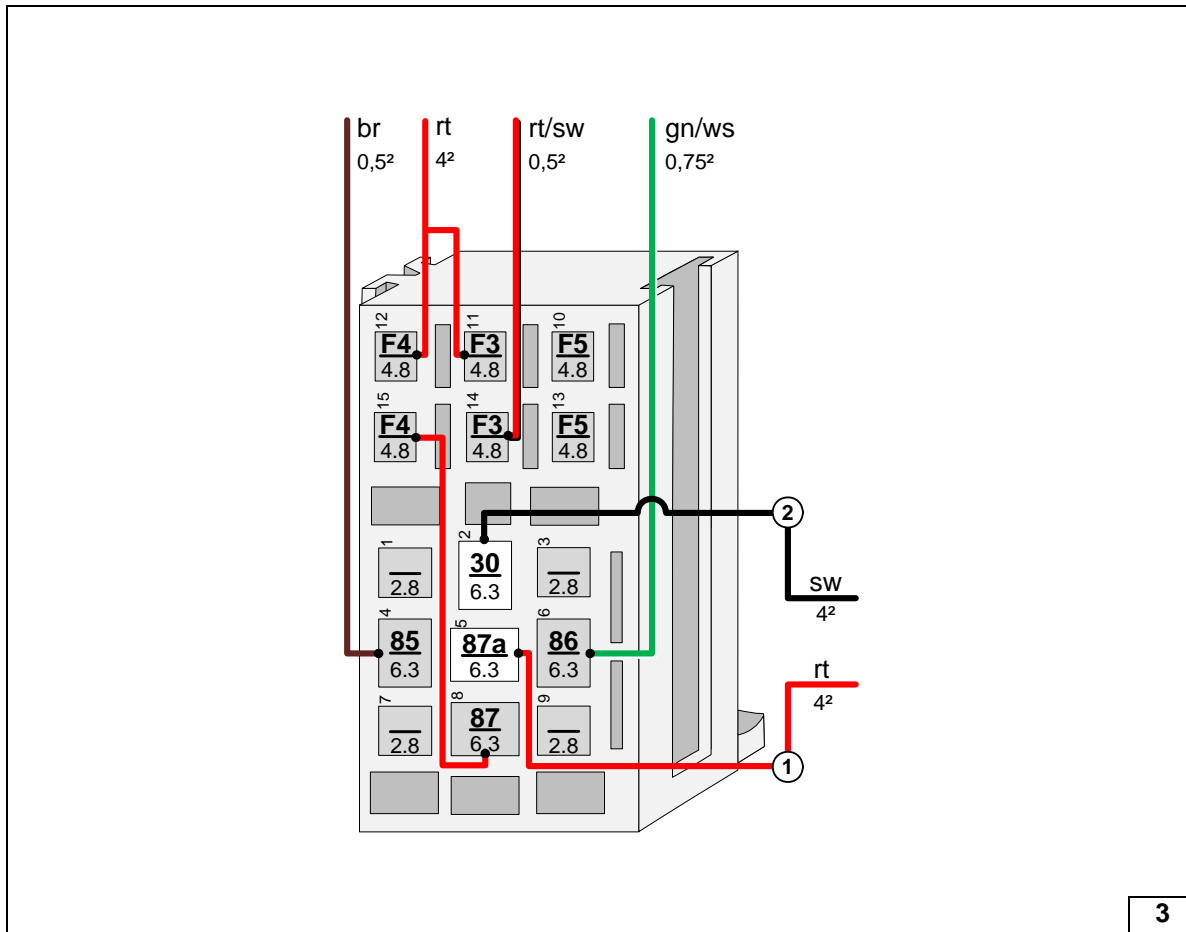

Connecting wires to socket of passenger compartment relay and fuse holder

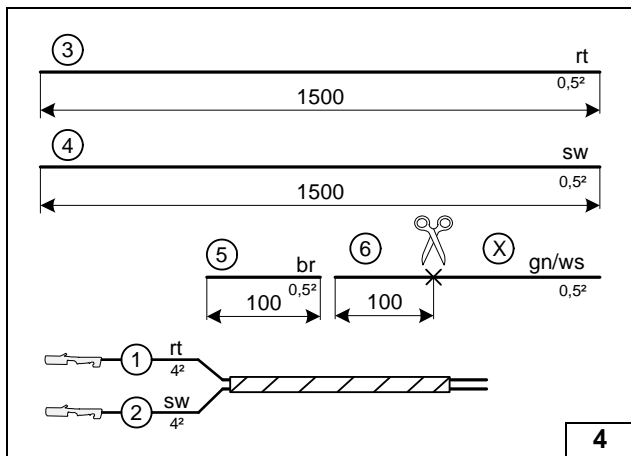

Automatic air-conditioning

Discard section X.
Pull wires ③ and ④ into a protective sleeving.

- ① Red (rt) wire of fan wiring harness
- ② Black (sw) wire of fan wiring harness



Cutting to length / assigning wires

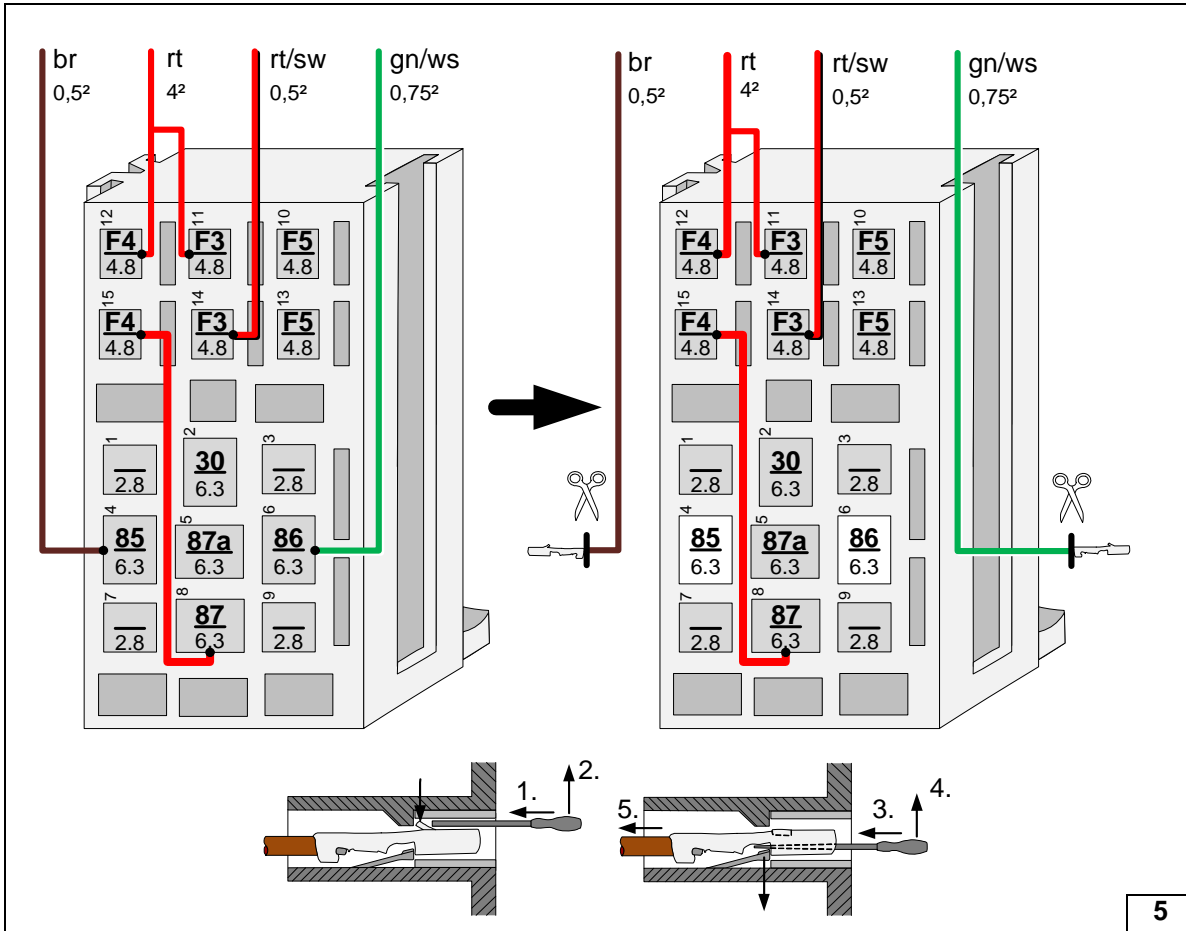
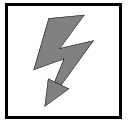

Preparing relay and fuse holder of passenger compartment

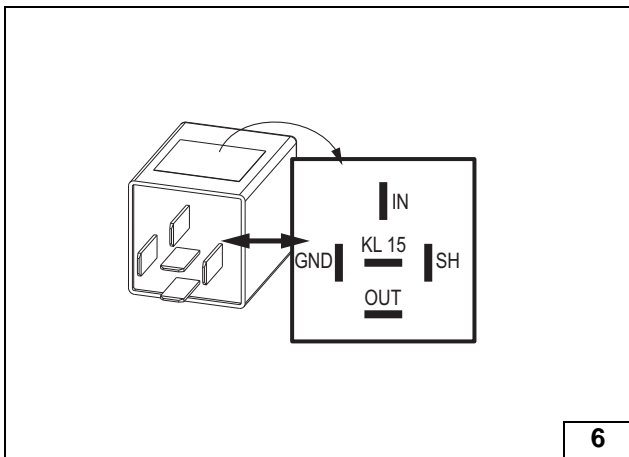

The settings of the PWM Gateway are to be checked before the heater start-up, and adjusted if necessary.



Settings:

- Duty cycle: 25%
- Frequency: 1000Hz
- Voltage: 4.8V
- Function: High side

View of PWM-GW

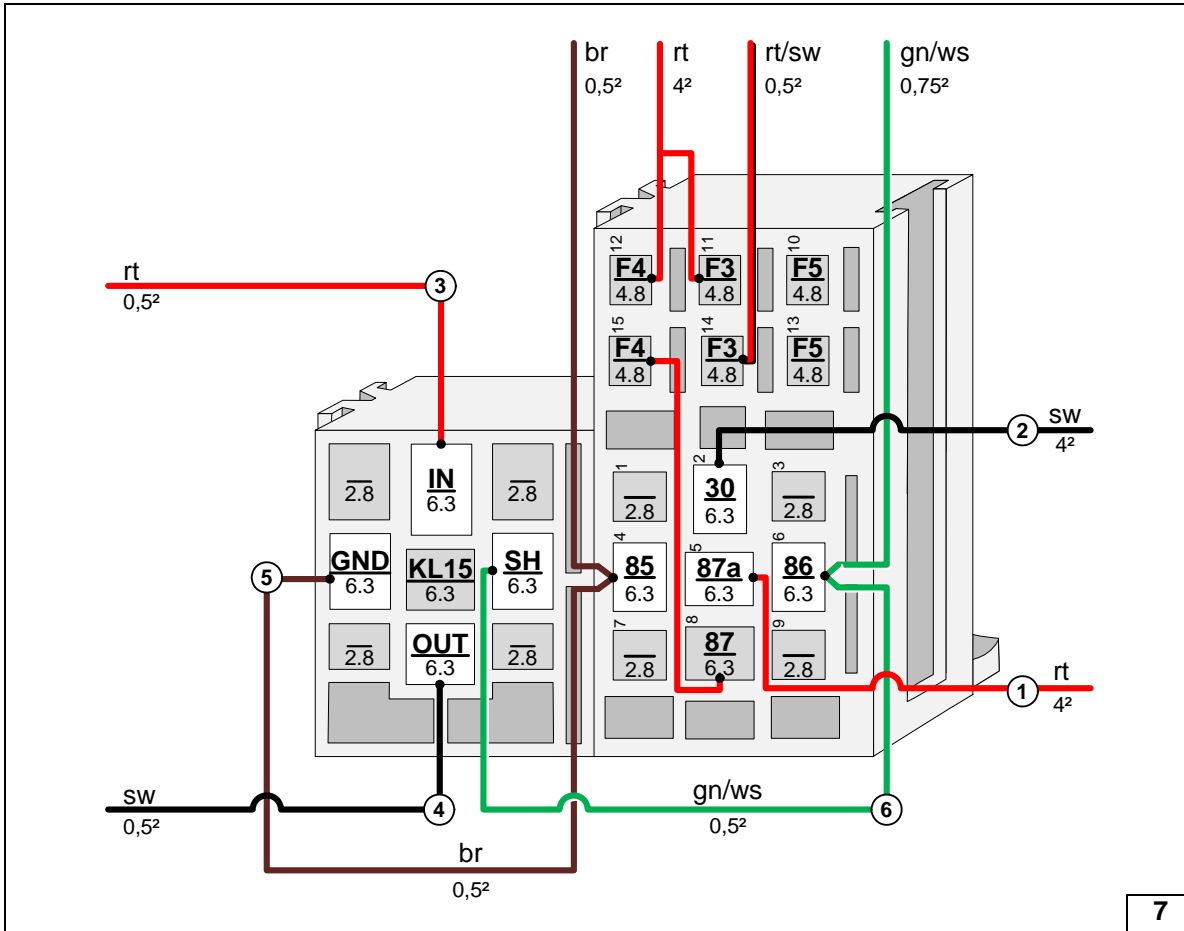
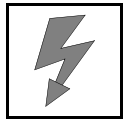

Connecting wires to sockets of PWM GW and passenger compartment relay and fuse holder, interconnecting sockets

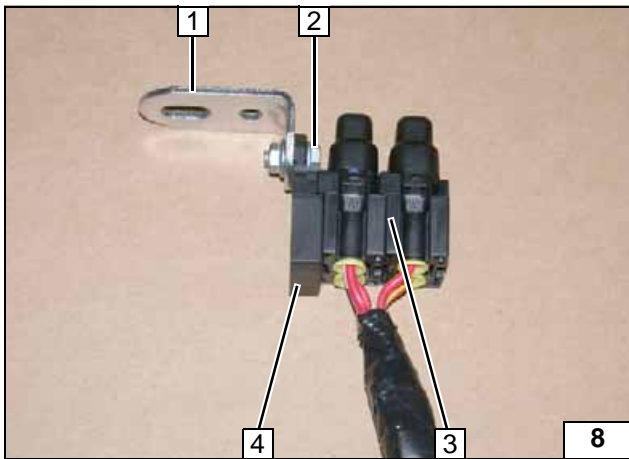

All vehicles

- 1 Angle bracket
- 2 M5x16 bolt, large diameter washer [2x], nut
- 3 Fuses F1-2
- 4 Retaining plate of fuse holder

Preparing engine compartment fuse holder

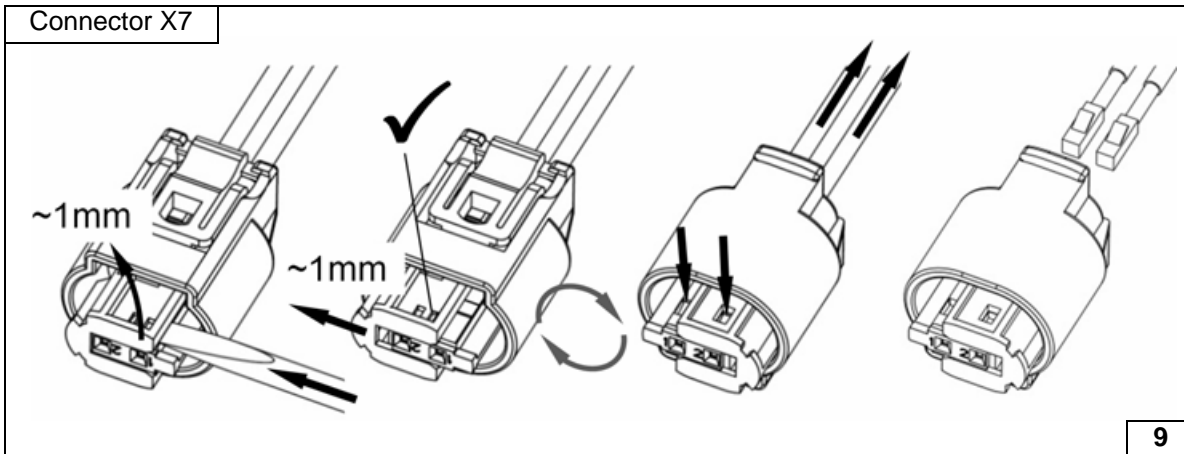

Removing metering pump connector



Electrical System

Wiring harness pass through of the engine compartment

- 1 17mm dia. hole, insert protective rubber plug
- 2 Wiring harness of heater, heater control

Wiring harness pass through of coolant reservoir

- 1 Protective rubber plug inserted (see image on left)
- 2 Original vehicle protective rubber plug
- 3 Wiring harness of heater, heater control
- 4 Cable tie [2x]

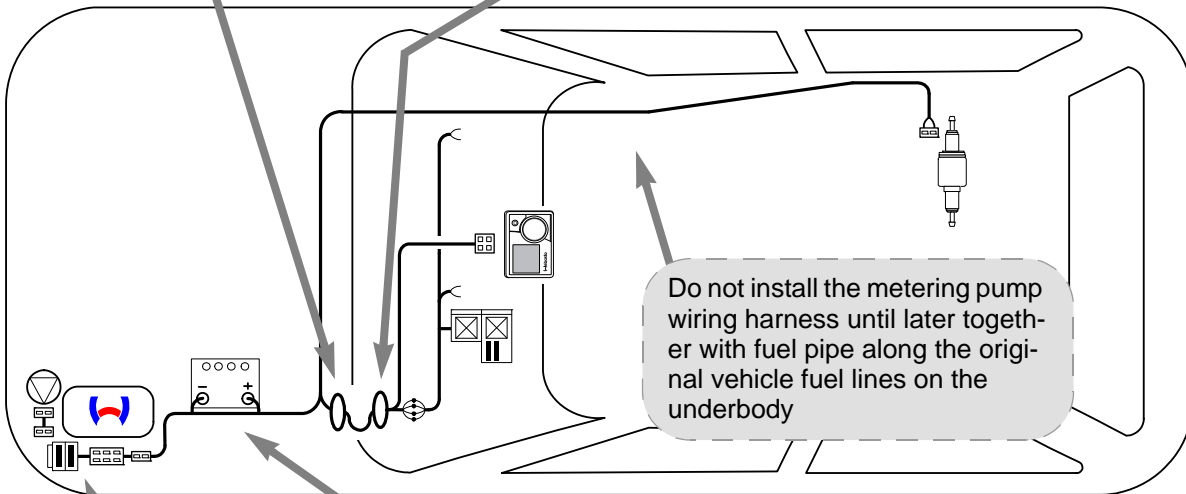
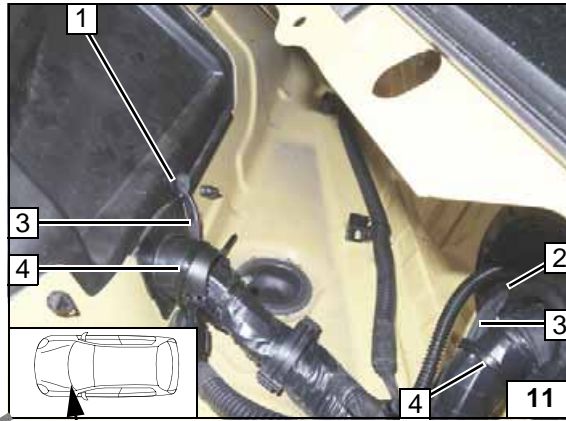
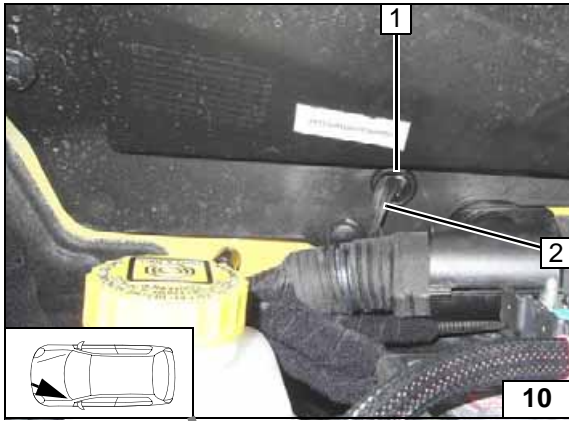

Wiring harness routing diagram

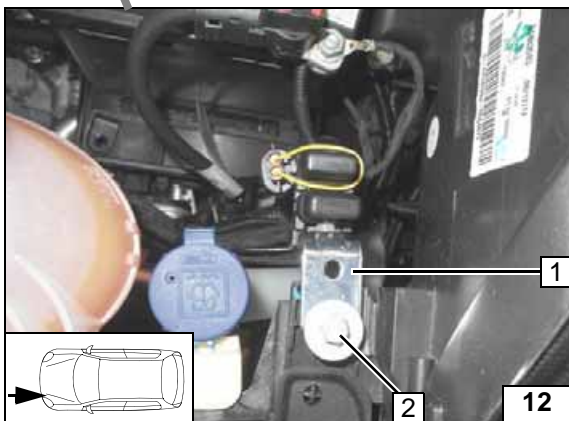

Engine compartment fuse holder

- 1 Angle bracket
- 2 Original vehicle bolt

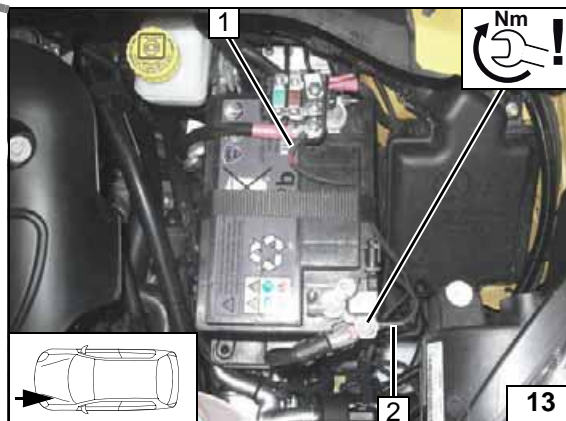

Positive and earth wire

- 1 Positive wire on positive battery terminal
- 2 Earth wire on negative battery terminal



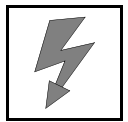

Fan Controller for Manual Air-Conditioning

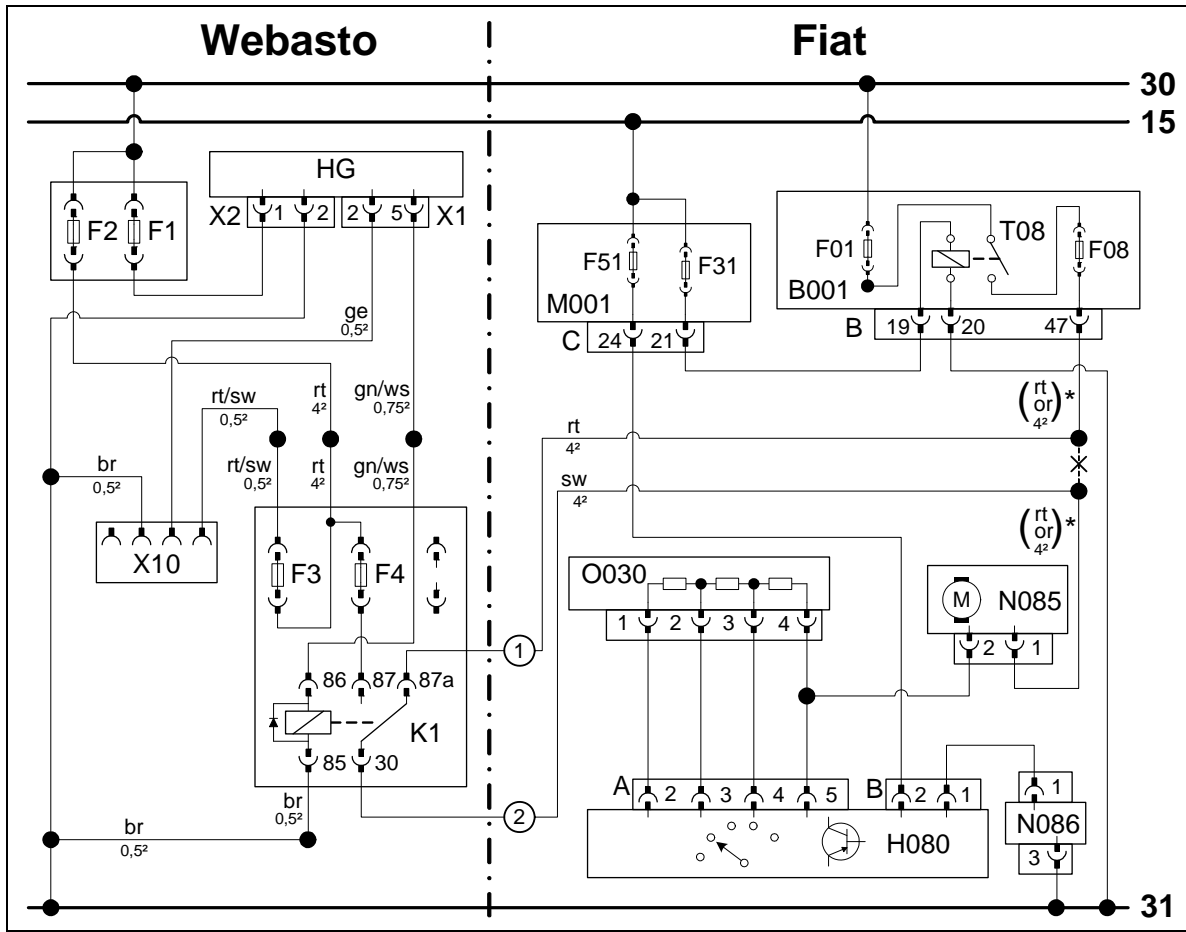

Wiring diagram

Webasto components		Vehicle components		Colours and symbols	
HG	TT-Evo Heater	B001	Central electrical box in engine compartment	rt	red
X1	6-pin heater connector	F01	70A fuse	sw	black
X2	2-pin heater connector	F08	40A fuse	ge	yellow
F1	20A fuse	F51	5A fuse	gn	green
F2	30A fuse	F31	5A fuse	ws	white
X10	4-pin connector of heater control	C	Connector M001	br	brown
F3	1A fuse	O030	Resistor group	or	orange
F4	25A fuse	N085	Fan motor		
K1	Fan relay	N086	Electr. thermostat		
		H080	Switch of A/C control panel	X	Cutting point
		A	Connector H080	*	Wiring colours may vary.
		B	Connector H080		

Legend

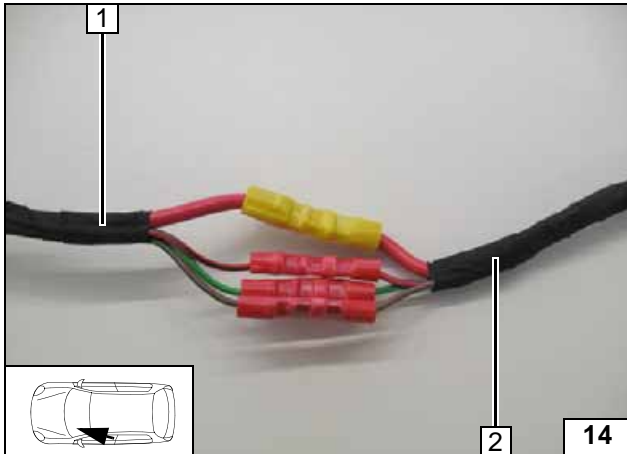

- 1 Wiring harness of passenger compartment relay and fuse holder
- 2 Wiring harness of heater

Connecting same colour wires of wiring harnesses

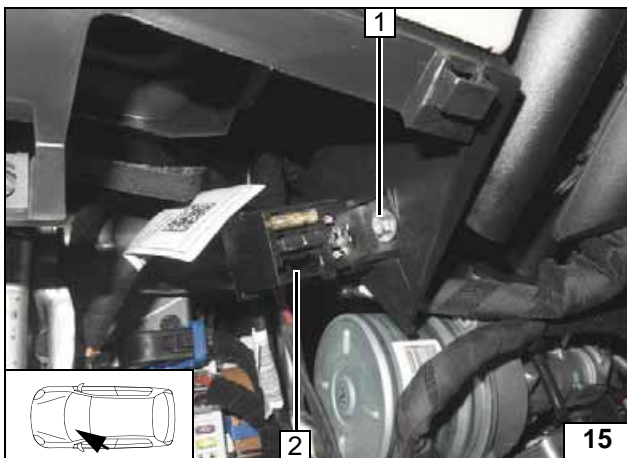

- 1 5.5 mm dia. hole, M5x16 bolt, large diameter washer [2x], nut
- 2 Passenger compartment relay and fuse holder

Installing relay and fuse holder of passenger compartment

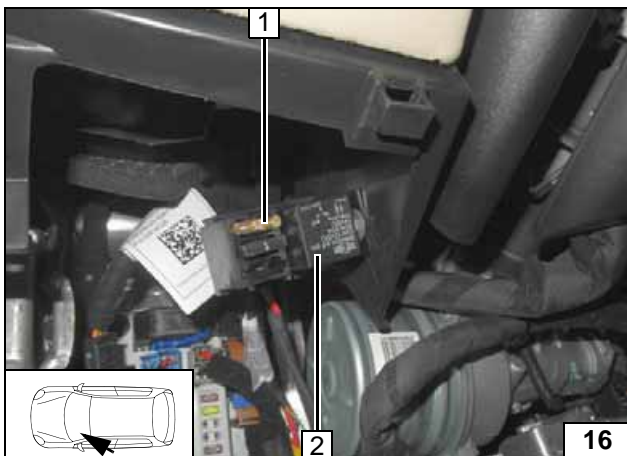

- 1 25A fuse F4
- 2 K1 relay

Installing K1 relay and F4 fuse

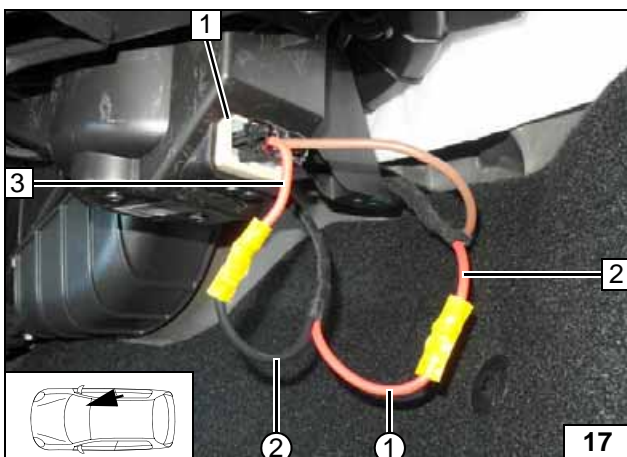

- 1 2-pin connector of fan motor N085
- 2 Red (rt) or orange (or) wire of fuse F08
- 3 Red (rt) or orange (or) wire of 2-pin connector N085/1
- ① Red (rt) wire from K1/87a, fan wiring harness
- ② Black (sw) wire from K1/30, fan wiring harness

Connection of fan motor

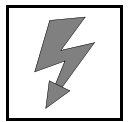

Fan Controller for Automatic Air-Conditioning

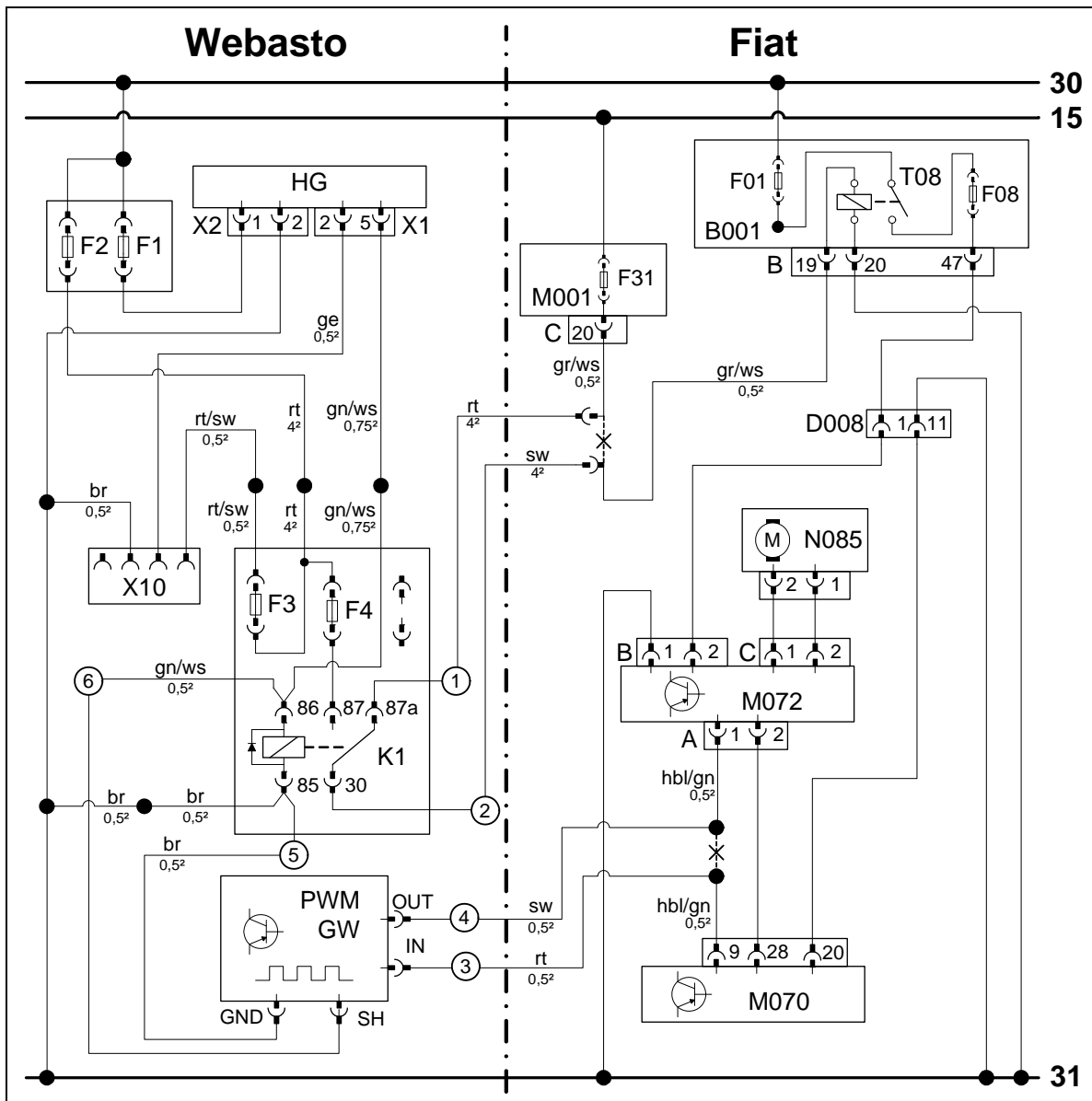

Wiring diagram

Webasto components		Vehicle components		Colours and symbols	
HG	TT-Evo Heater	B001	Central electrical box in engine compartment	rt	red
X1	6-pin heater connector	T08	Fan relay	sw	black
X2	2-pin heater connector	F01	70A fuse	ge	yellow
F1	20A fuse	F08	40A fuse	gn	green
F2	30A fuse	B	Connector B001	br	brown
X10	4-pin connector of heater control	M001	Body computer	gr	grey
F3	1A fuse	F31	5A fuse	ws	white
F4	5A fuse	C	20-pin connector M001		
K1	Fan relay	D008	Plug connection		
PWM GW	Pulse width modulator	N085	Fan motor		
Settings of PWM GW:		M072	Fan controller		
Duty cycle: 25%		A	M072 connector		
Frequency: 1000Hz		B	M072 connector		
Voltage: 4.8V		C	M072 connector		
Function: High side		M070	A/C control unit	X	Cutting point
				Wiring colours may vary.	

Legend

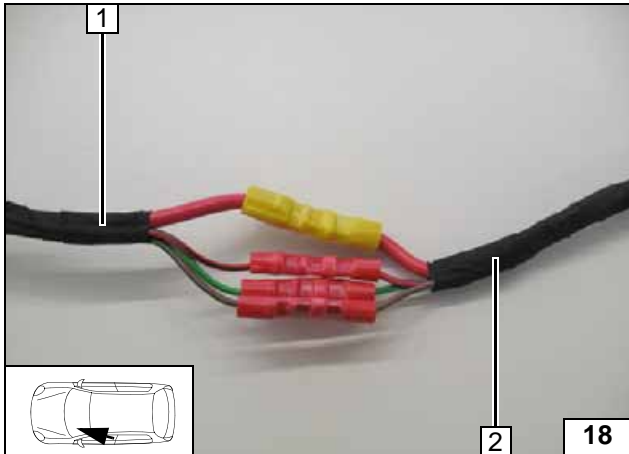

- 1 Wiring harness of passenger compartment relay and fuse holder
- 2 Wiring harness of heater

Connecting same colour wires of wiring harnesses

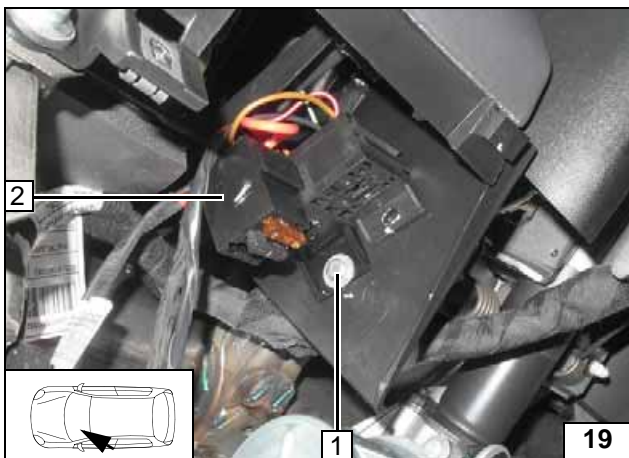

- 1 5.5 mm dia. hole, M5x16 bolt, large diameter washer [2x], nut
- 2 Passenger compartment relay and fuse holder

Installing relay and fuse holder of passenger compartment

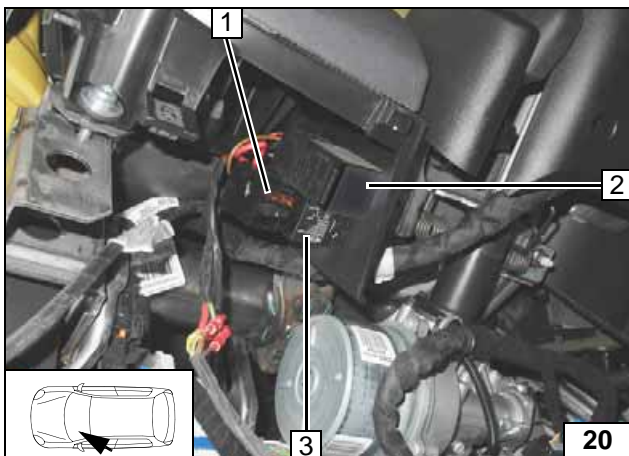

- 1 5A fuse F4
- 2 PWM GW
- 3 K1 relay

Installing K1 relay, PWM GW and fuse F4

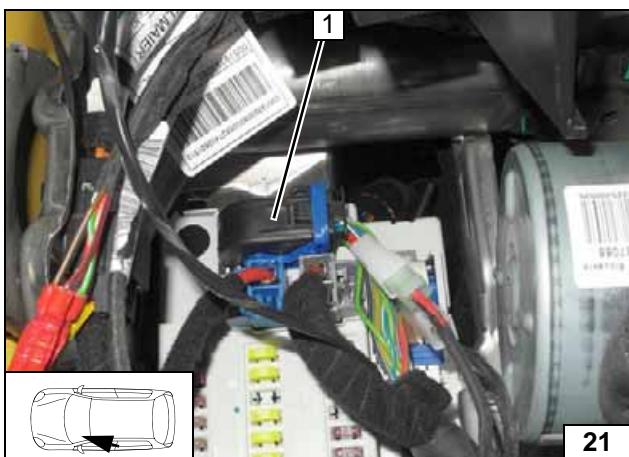

Detach 20-pin connector C 1 from Body Computer (M001) and dismantle.



Connection of Body Computer

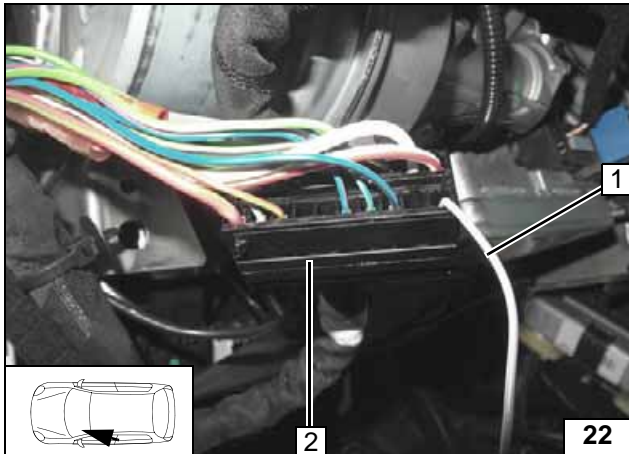

Separate grey/white (gr/ws) wire 1 100mm behind the plug connection. Reassemble the connector housing.

- 1 Grey/white (gr/ws) wire of connector C, pin 20
- 2 20-pin connector C (M001)

**Connec-
tion of
Body Com-
puter**

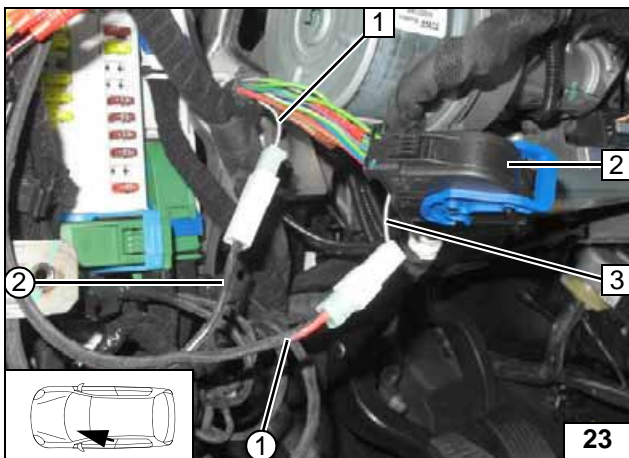

- 1 Grey/white (gr/ws) wire of connector B (B001), pin 19
- 2 20-pin connector C (M001)
- 3 Grey/white (gr/ws) wire of connector C (M001), pin 20
- ① Red (rt) wire from K1/87a, fan wiring harness
- ② Black (sw) wire from K1/30, fan wiring harness

**Connec-
tion of
Body Com-
puter**

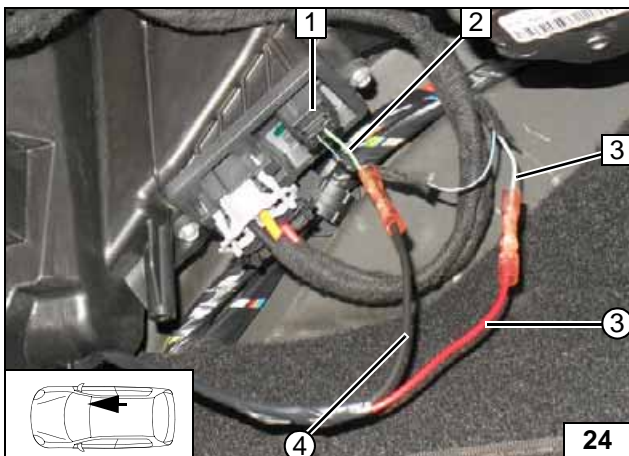

- 1 2-pin connector A (M072)
- 2 Light blue/green (hbl/gn) wire of connector A (M072), pin 1
- 3 Light blue/green (hbl/gn) wire of connector (M070), pin 9
- ③ Red (rt) wire of PWM GW/IN
- ④ Black (sw) wire of PWM GW/OUT

**Connec-
ting fan con-
troller**

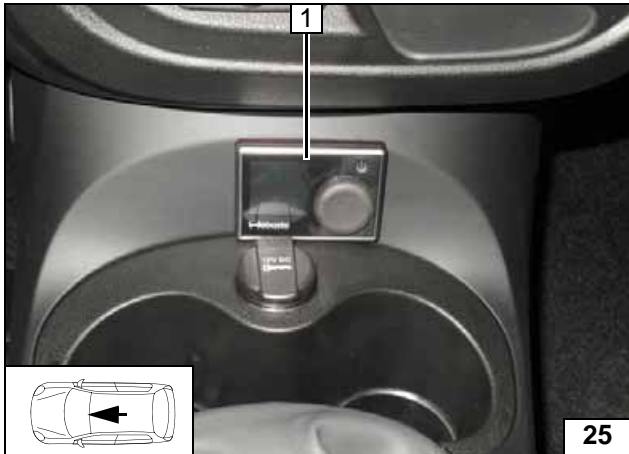

MultiControl CAR Option

- 1 MultiControl CAR



Installing
MultiControl
CAR

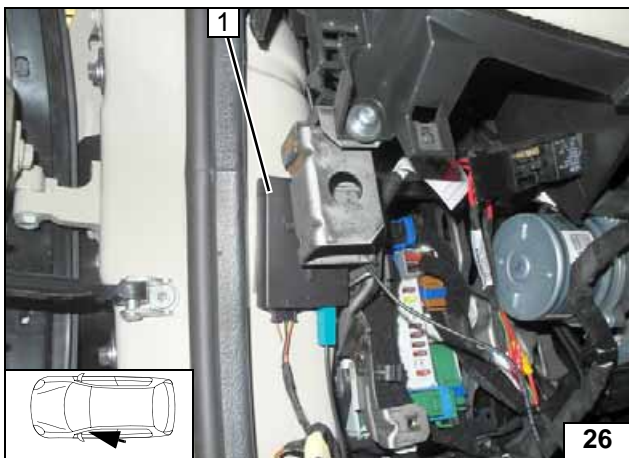

Remote Option (Telestart)

Degrease adhesive base. Fasten receiver 1 with adhesive tape.



Installing
receiver

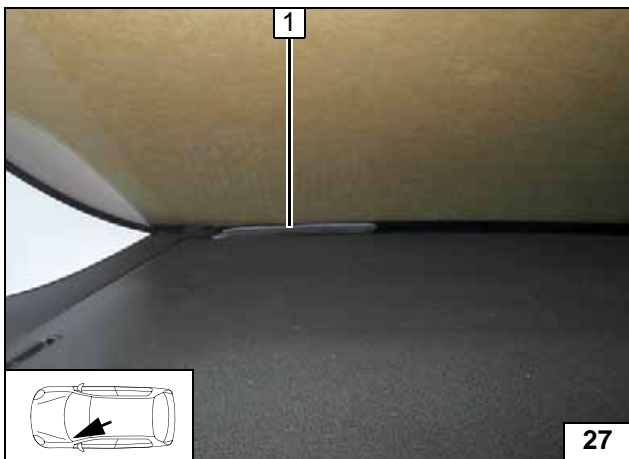

- 1 Antenna

Installing
antenna

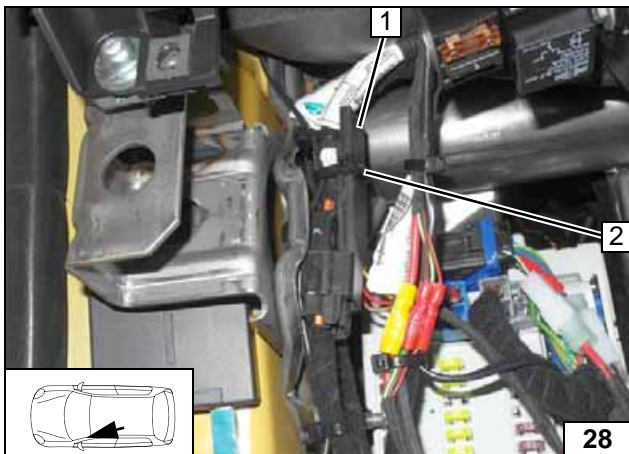

Temperature sensor T100 HTM

Fasten temperature sensor 1 using cable tie 2 to original vehicle wiring harness.



Installing
temperature
sensor



Remote Option (Thermo Call)

Degrease adhesive base. Fasten receiver 1 with adhesive tape.

Installing receiver

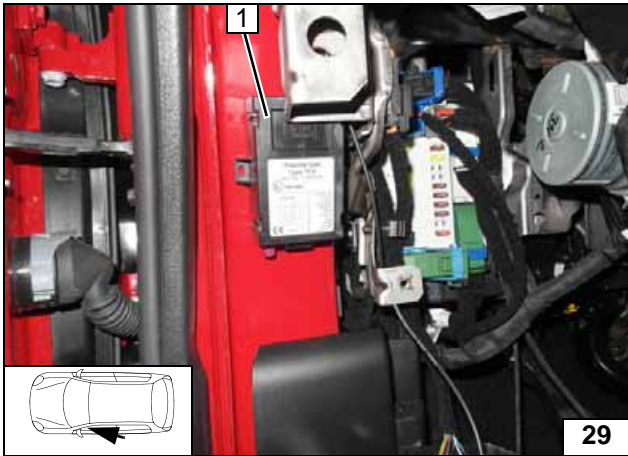

1 Antenna

Installing antenna

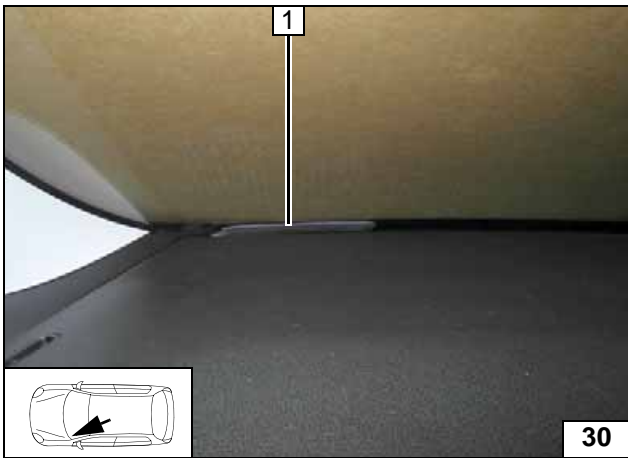

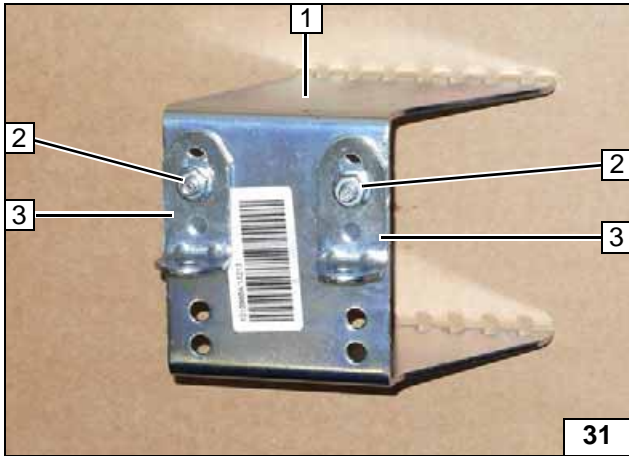
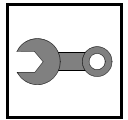

Preparing Installation Location

- 1 Bracket
- 2 Loosely mount M6x12 bolt, flanged nut [2x each]
- 3 Angle bracket [2x]

Preparing bracket

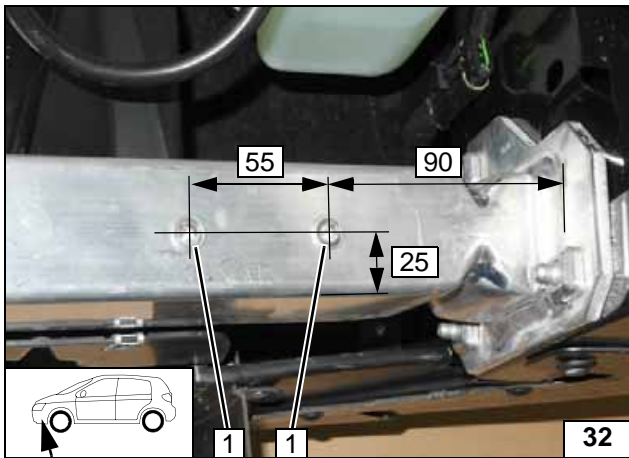

- 1 9.1mm dia. hole; rivet nut [2x each]

Installing rivet nuts

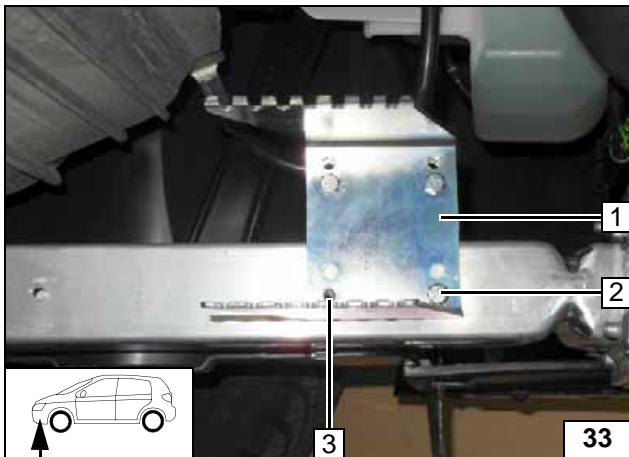

Align hole of bracket with rivet nut at position 3 in such a way that they are congruent.

- 1 Bracket
- 2 M6x20 bolt, spring lockwasher

Loosely mount bracket

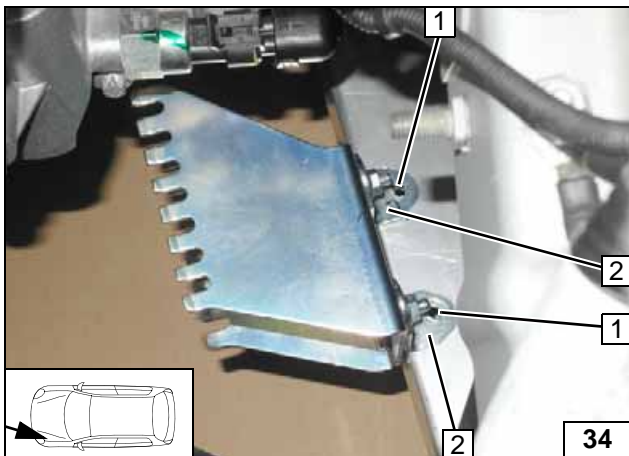

Align angle bracket 2 [2x] with frame side member.

- 1 Copy hole pattern [2x]

Copying hole pattern

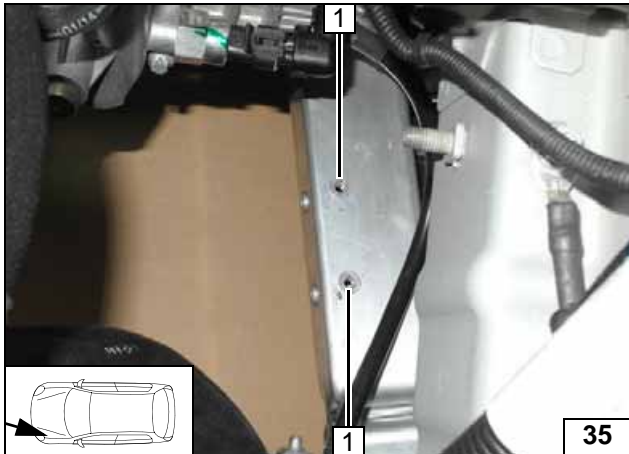

Remove bracket.

- 1 9.1mm dia. hole; rivet nut [2x each]



Installing rivet nut

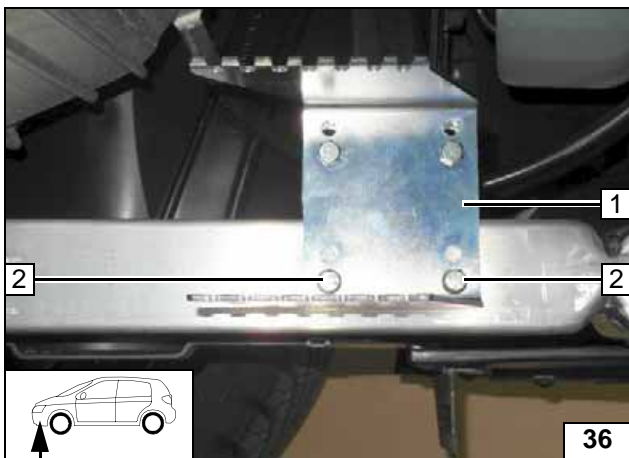

- 1 Bracket
- 2 M6x20 bolt, spring lockwasher [2x each]

Installing bracket

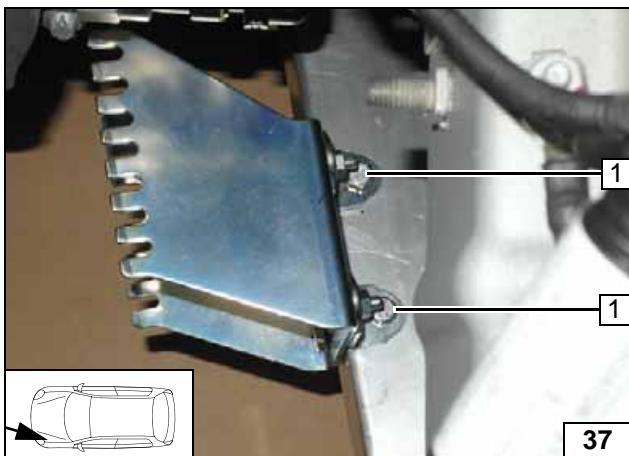

- 1 M6x20 bolt, spring lockwasher [2x each]

Installing bracket

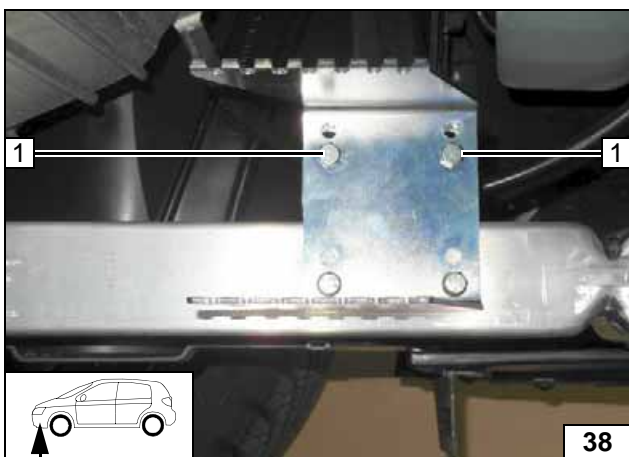

- 1 Tighten M6x12 bolt, flanged nut [2x each]

Installing bracket

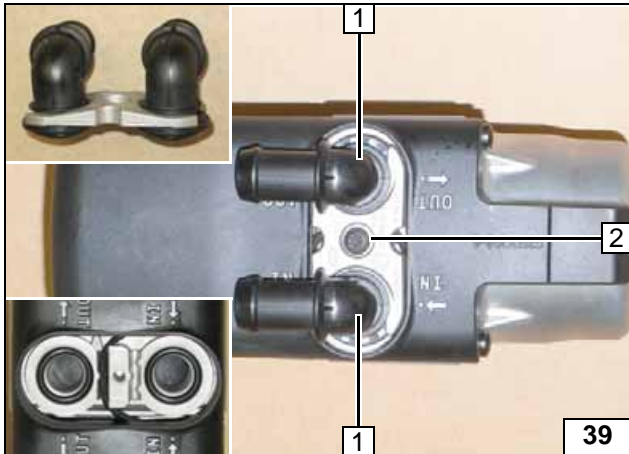

Preparing Heater

- 1 Water connection piece, sealing ring [2x each]
- 2 5x15 self-tapping bolt, retaining plate of water connection pieces



Installing water connection pieces

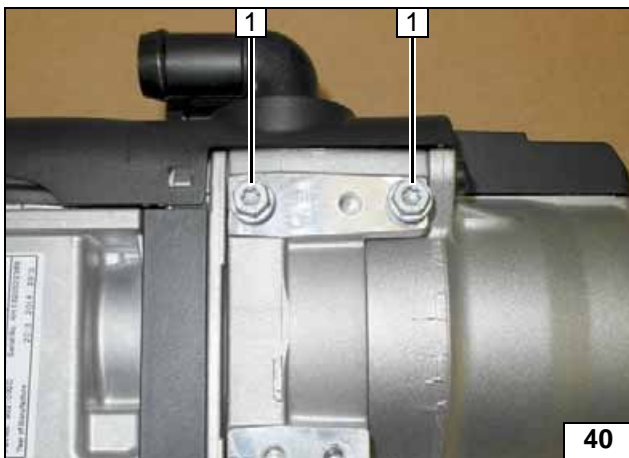

Screw 5x13 self-tapping bolts 1 [2x] into existing holes by a maximum of 3 thread turns.



Premounting bolts loosely

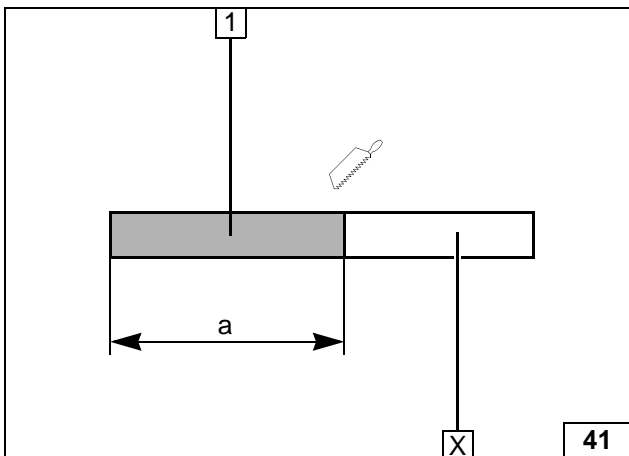

Discard section X.

- 1 Combustion air pipe
a = 160



Cutting combustion air pipe to length

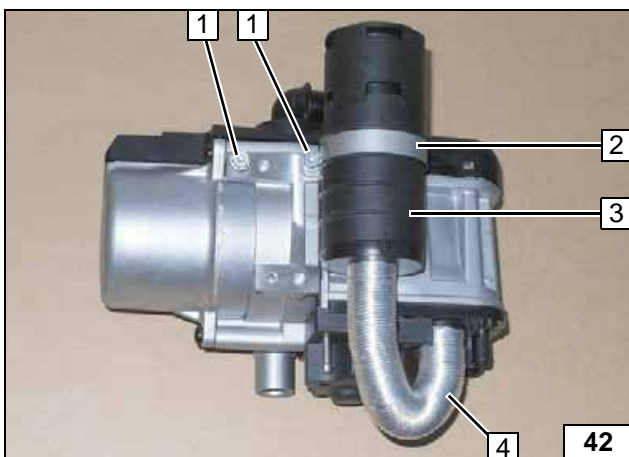

Screw 5x13 self-tapping bolts 1 [2x] into existing holes by a maximum of 3 thread turns.

- 2 Mount 51 mm dia. clamp loosely
- 3 Combustion air silencer
- 4 Combustion air pipe



Premounting heater

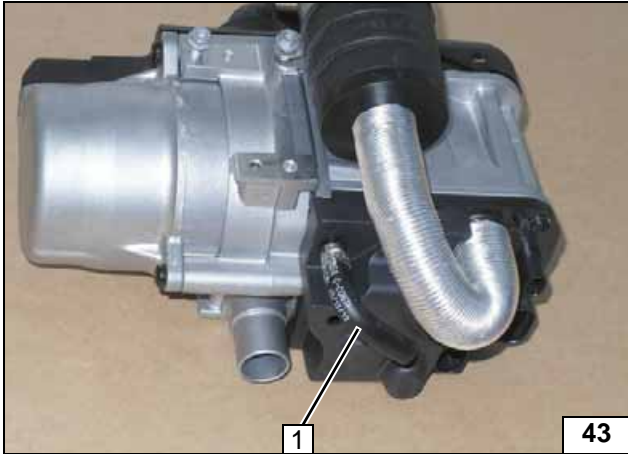
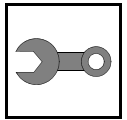

1 90° moulded hose, 10mm dia. clamp

Mounting
moulded
hose

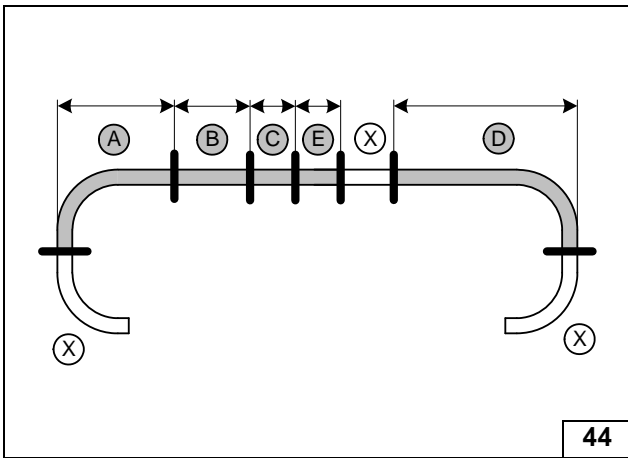

Discard section X.

- A = 530
- B = 400
- C = 75
- D = 780
- E = 70

Cutting
hoses to
length

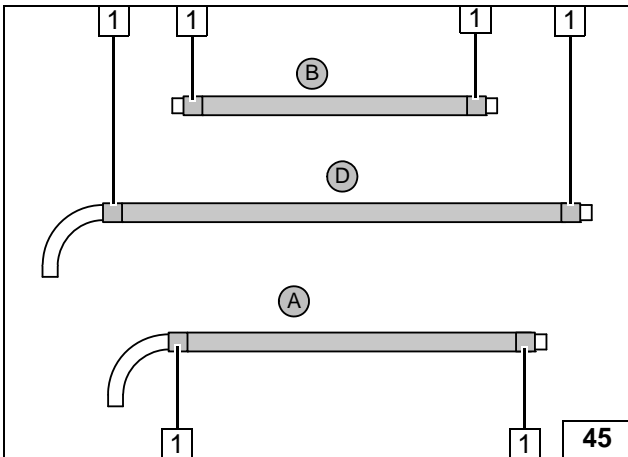

Push braided protection hoses onto hoses **A**, **B** and **D** and cut to length. Cut heat shrink plastic tubing to length.

1 50 mm long heat shrink plastic tubing [6x]

Preparing
hoses

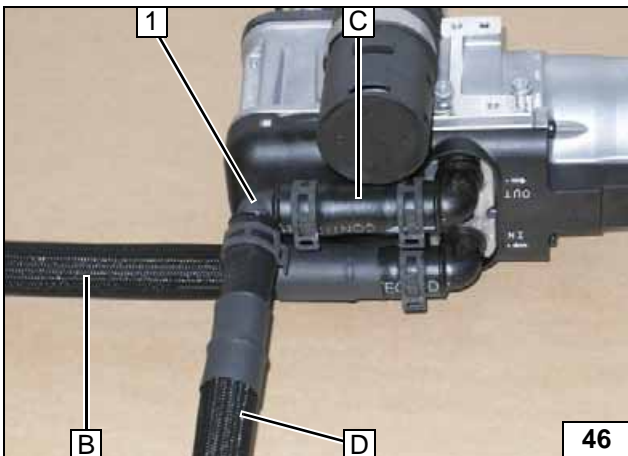

All spring clips = 25mm dia.

1 18x18mm, 90° connecting pipe

Premount-
ing hoses

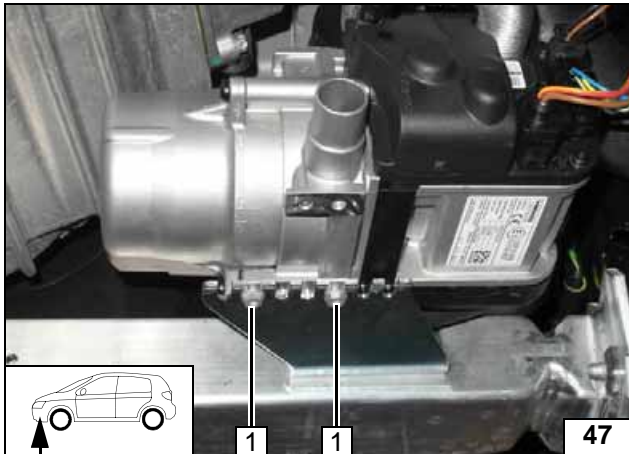

Installing Heater

- 1 Tighten 5x13 self-tapping bolt [2x]

Installing heater

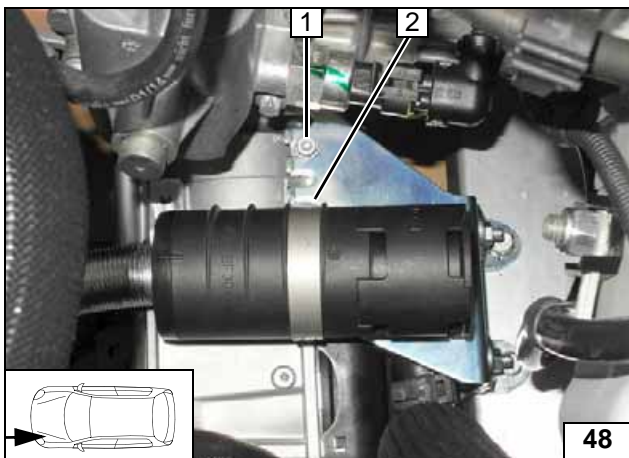

Tighten 5x13 self-tapping bolt at position 2 (hidden by 51mm dia. clamp)!

- 1 Tighten 5x13 self-tapping bolt



Installing heater

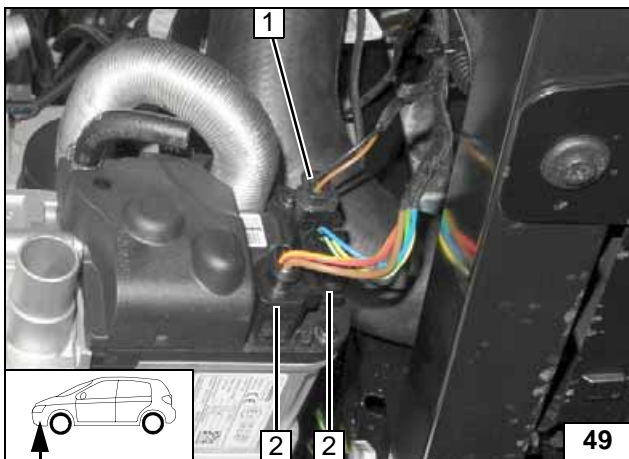

- 1 Connector of circulating pump wiring harness
- 2 Connector of heater wiring harness [2x]

Mounting wiring harness

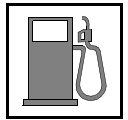

Fuel

CAUTION!

Open the vehicle's fuel tank cap, ventilate the tank and then re-close the tank lock.

Catch any fuel running off in an appropriate container.

Install fuel line and metering pump wiring harness so that they are protected against stone impact. Unless specified otherwise, always fasten using cable ties. Provide rub protection for fuel line and wiring harness in areas where there are sharp edges.

WARNING!

The fuel line and wiring harness are routed to the metering pump as shown in the wiring harness routing diagram.



Connect-
ing heater



Installing
lines



Installing
lines

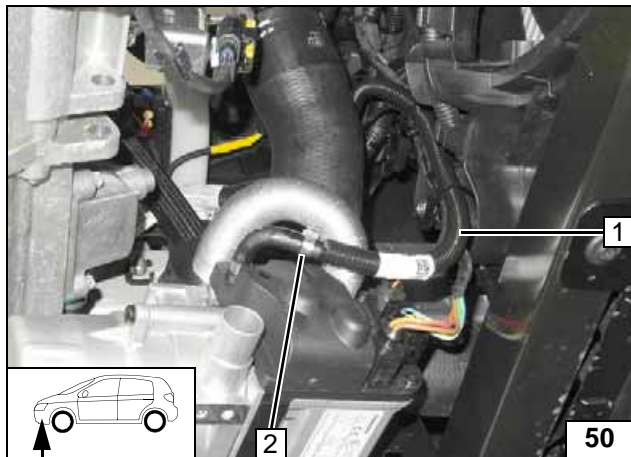

Pull fuel line and wiring harness of metering pump into 10mm dia. corrugated tube 1 and route upwards.

2 Fuel line, 10 mm dia. clamp

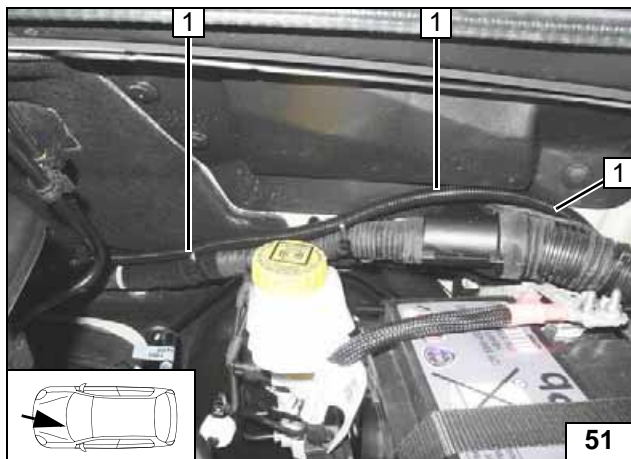

Route fuel line and wiring harness of metering pump in corrugated tube 1 to the right side along original vehicle wiring harness and further to the underbody along original vehicle fuel line and fasten.



Route fuel line and wiring harness of metering pump in corrugated tube 1 to the installation location of the metering pump along original vehicle lines and fasten.

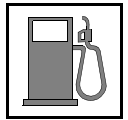

Preparing perforated bracket

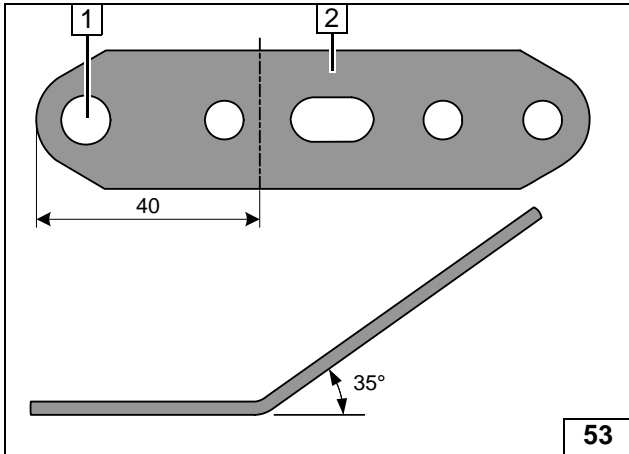

- 1 Drill out hole to 8.5 mm dia.
- 2 Perforated bracket

53

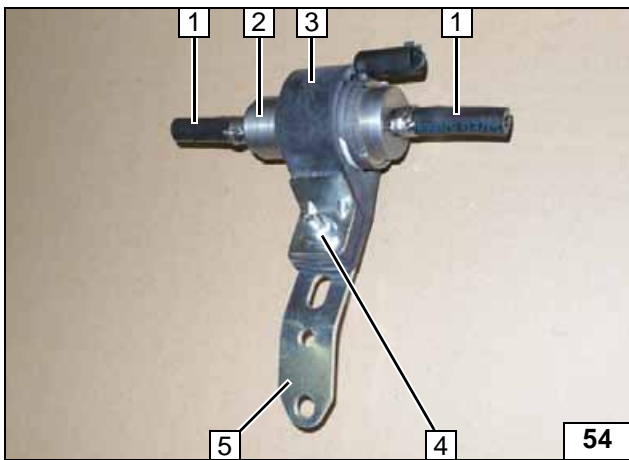

- 1 Hose section, 10mm dia. clamp [2x each]
- 2 Metering pump
- 3 Mounting of metering pump
- 4 M6x25 bolt, support angle bracket and flanged nut
- 5 Perforated bracket

54

Premounting metering pump

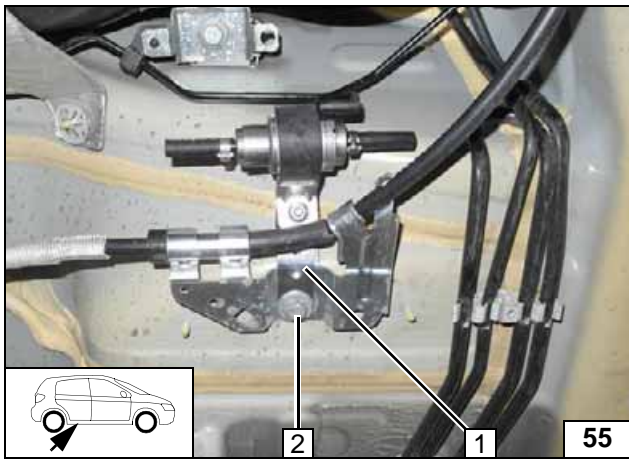

- 1 Perforated bracket
- 2 Original vehicle bolt

55

Installing metering pump

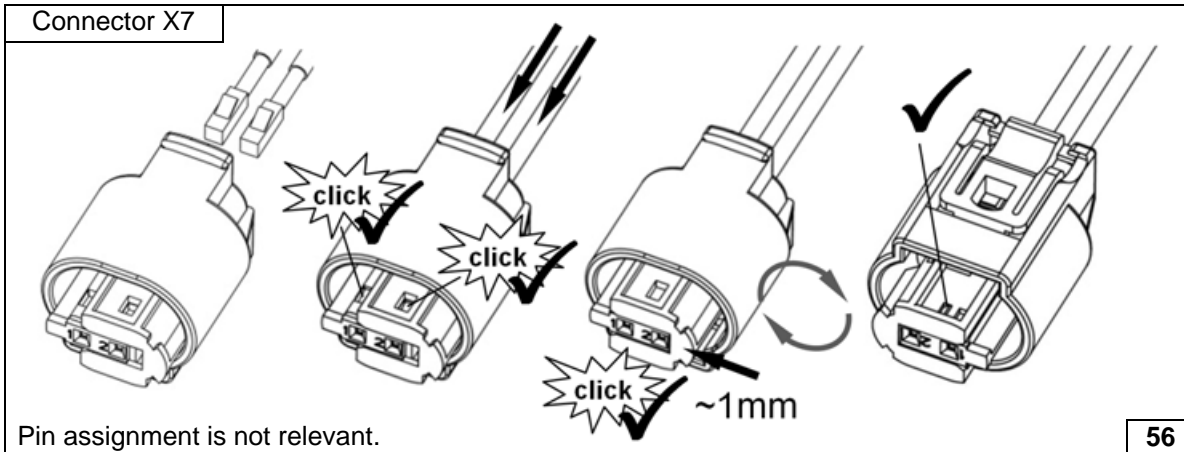

Completing metering pump connector

56

Pin assignment is not relevant.

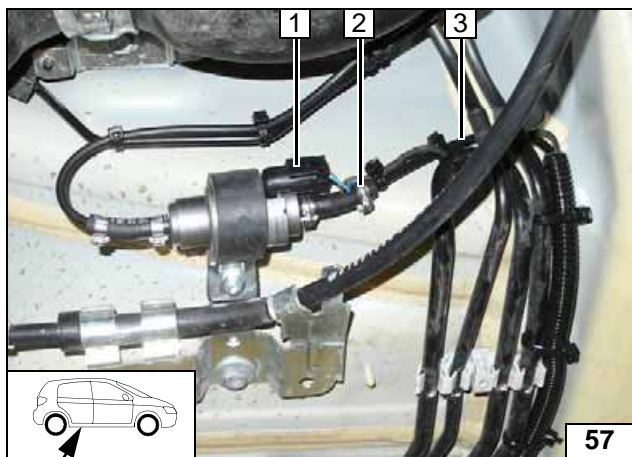
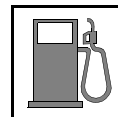

- 1 Wiring harness of metering pump, connector X7 mounted
- 2 10mm dia. clamp
- 3 Fuel line of heater

**Connect-
ing meter-
ing pump**

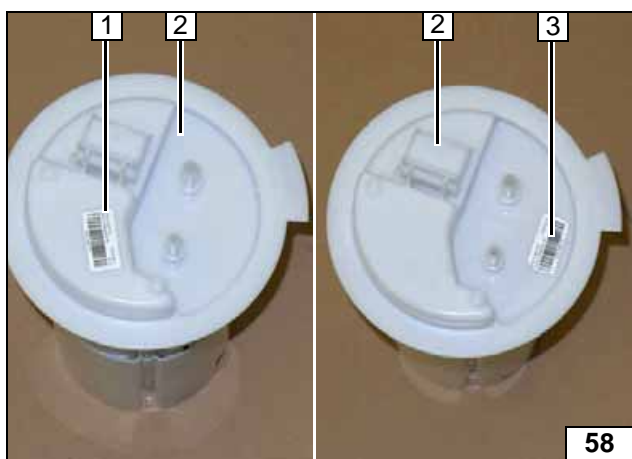

Remove fuel-tank sending unit **2** in accordance with the manufacturer's instructions.

- 1 Pos. sticker before
- 3 Pos. sticker after



**Moving
sticker**

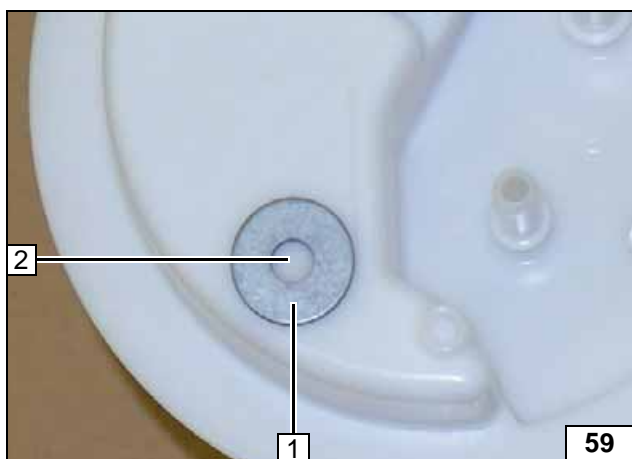

Place large diameter washer with outer dia. $d_a = 21.6\text{mm}$ **1** as shown.

- 2 Copy hole pattern, 6mm dia. hole



**Fuel extrac-
tion**

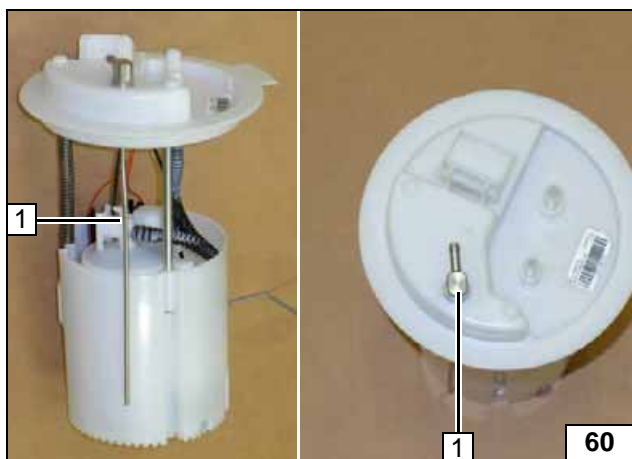

Shape fuel standpipe **1** according to template and cut to length.



**Installing
fuel stand-
pipe**

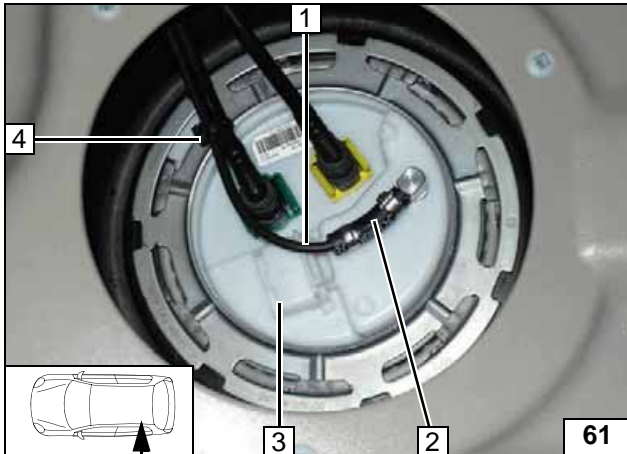
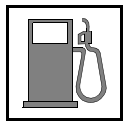

Install fuel-tank sending unit **3** in accordance with manufacturer's instructions.

- 1 Fuel line
- 2 Hose section, 10mm dia. clamp [2x]
- 4 Cable tie



**Connect-
ing fuel line**

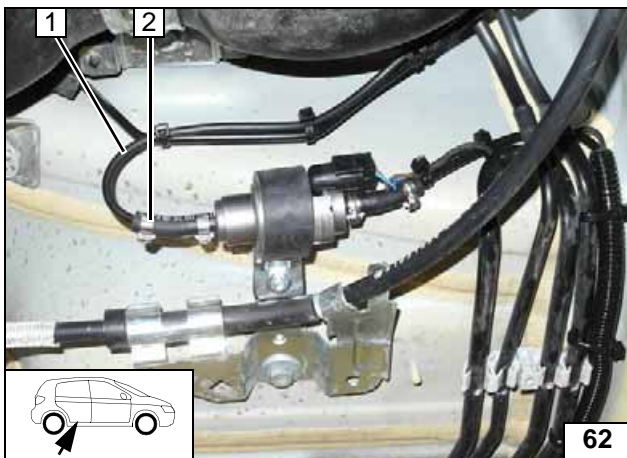

Check the position of the components; adjust if necessary. Check that they have freedom of movement.

- 1 Fuel line of fuel standpipe
- 2 10mm dia. clamp



**Connect-
ing meter-
ing pump**







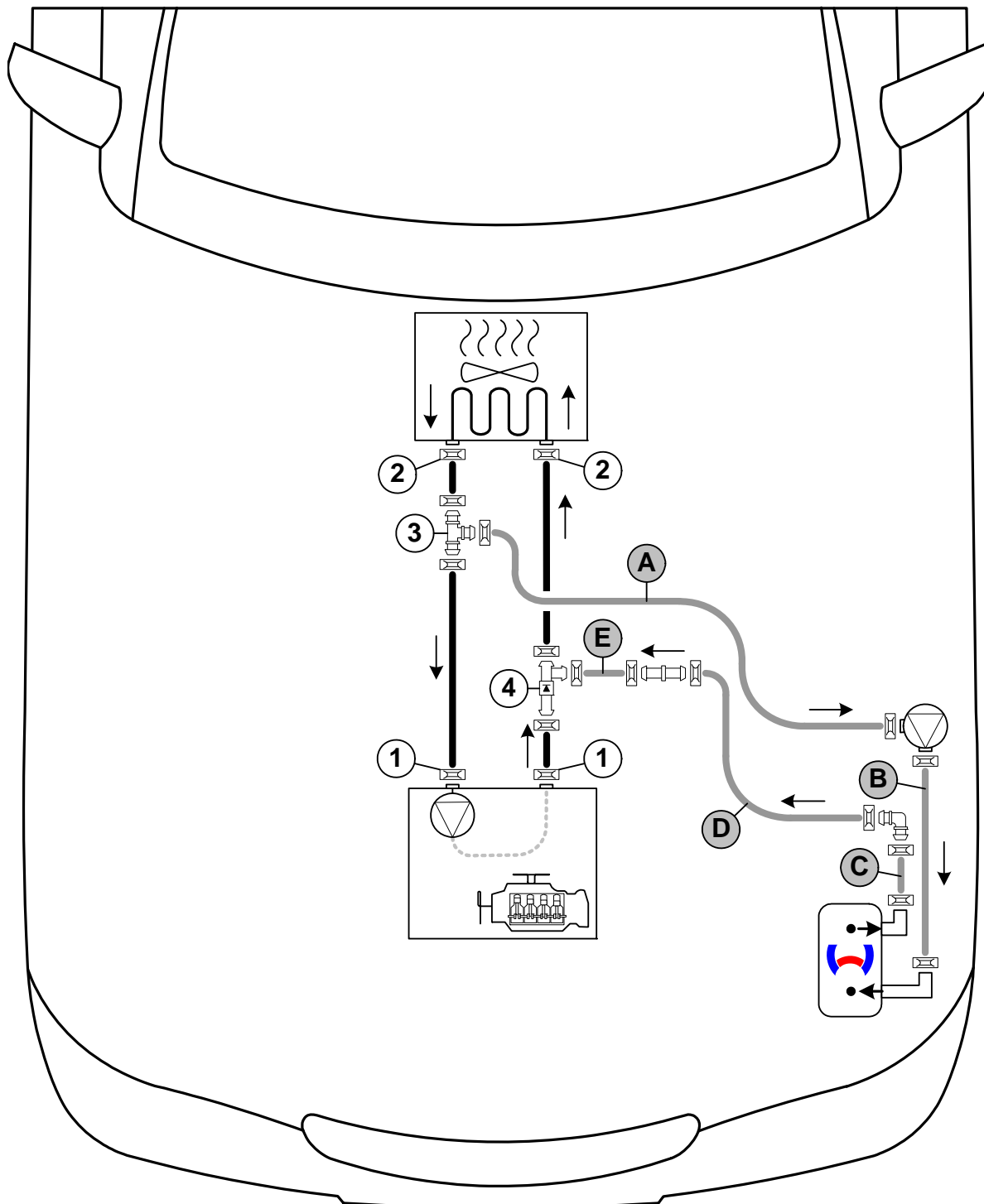

Coolant Circuit

WARNING!

Any coolant running off should be collected in an appropriate container. Install hoses so that they are kink-free. Unless specified otherwise, always fasten using cable ties. Position clamps so that other hose cannot be damaged. When installing the hoses, the heater must be filled with coolant. The connection should be modelled on an "island" circuit and based on the following diagram:



Hose routing diagram

All spring clips without specific designation  = 25mm dia. **1** = Original vehicle clamp .
2 = Original vehicle clamp  with coupling piece. All connecting pipes  and  = 18x18 mm dia.
3 = T-piece . **4** = Check valve 



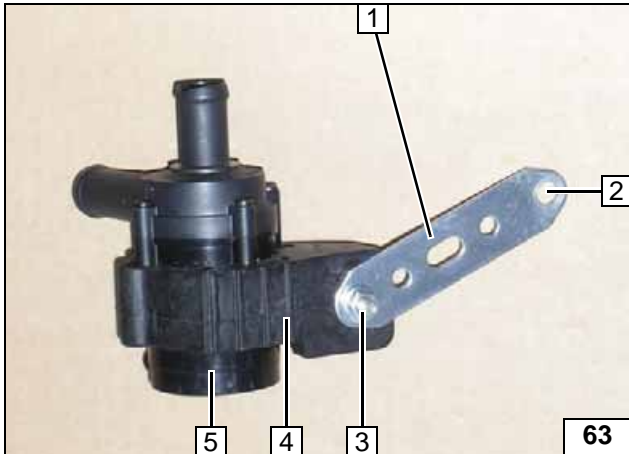

- 1 Perforated bracket
- 2 Drill out hole to 8.5 mm dia.
- 3 M6x25 bolt, flanged nut
- 4 Circulating pump mounting
- 5 Circulating pump

Premounting circulating pump

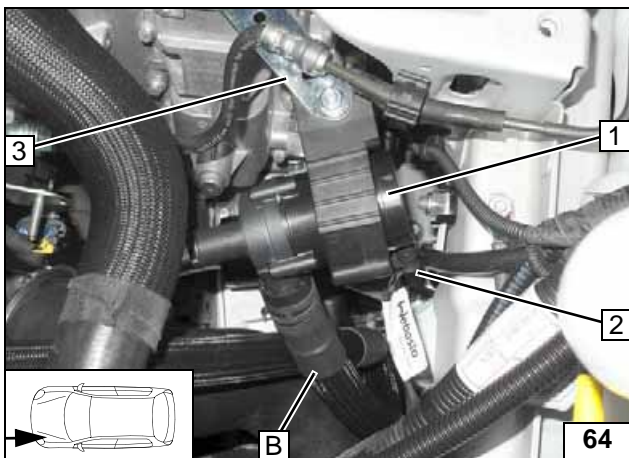

Perforated bracket 3 of the circulating pump mounting will be installed later together with the battery carrier!



- 1 Circulating pump
- 2 Connector of circulating pump wiring harness

Connecting circulating pump

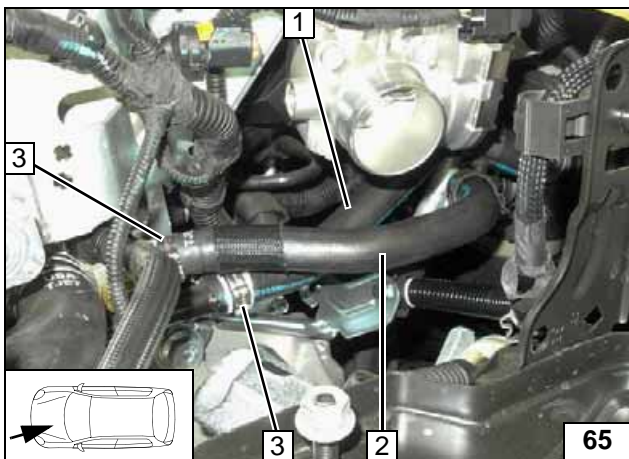

Remove hose of heat exchanger outlet / engine inlet 1 and hose of engine outlet / heat exchanger inlet 2. Detach clamp 3 [2x], will be reused!



Cutting point

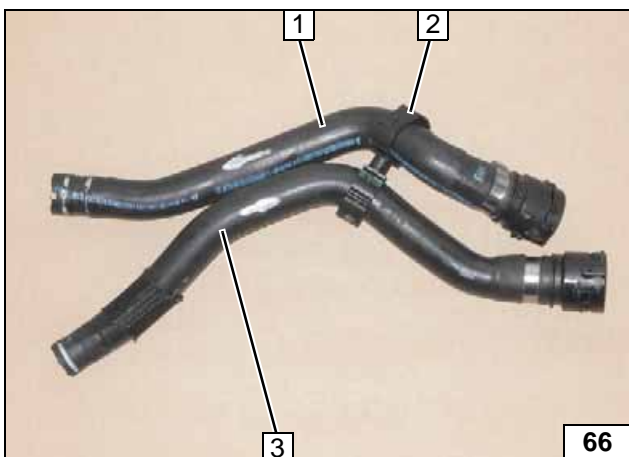

- 1 Hose on heat exchanger outlet / engine inlet
- 2 Remove original vehicle hose bracket and discard
- 3 Hose of engine outlet / heat exchanger inlet

Cutting point

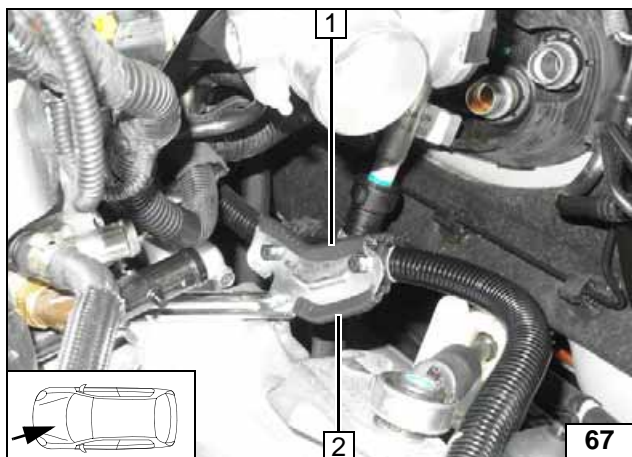

Cut edge protection to length!

- 1 70 mm edge protection
- 2 30 mm edge protection

Installing edge protection

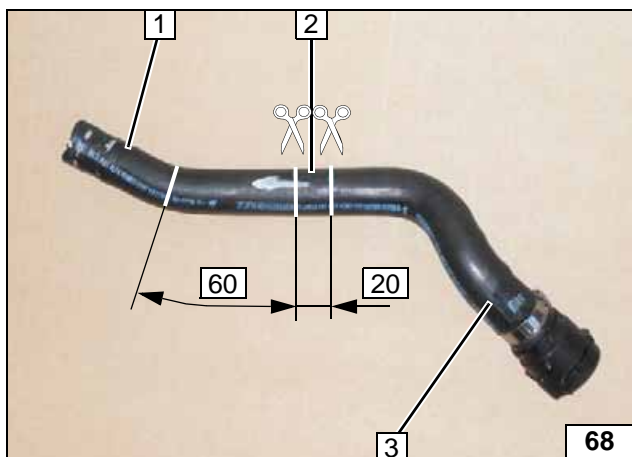

- 1 Hose section of engine inlet
- 2 Discard 20 mm section
- 3 Hose section of heat exchanger outlet

Cutting point

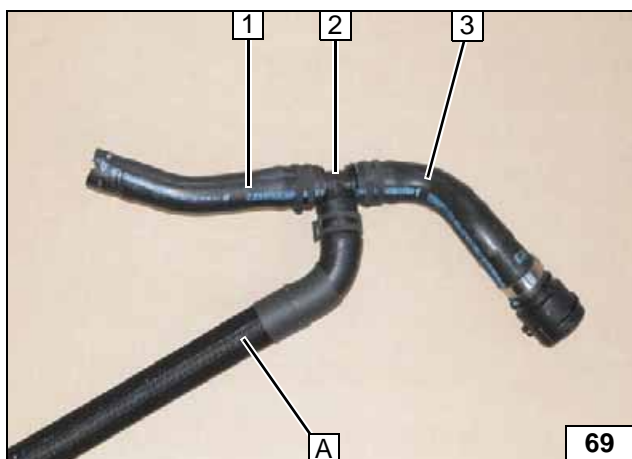

- 1 Hose section of engine inlet
- 2 T-piece
- 3 Hose section of heat exchanger outlet

Installing T-piece

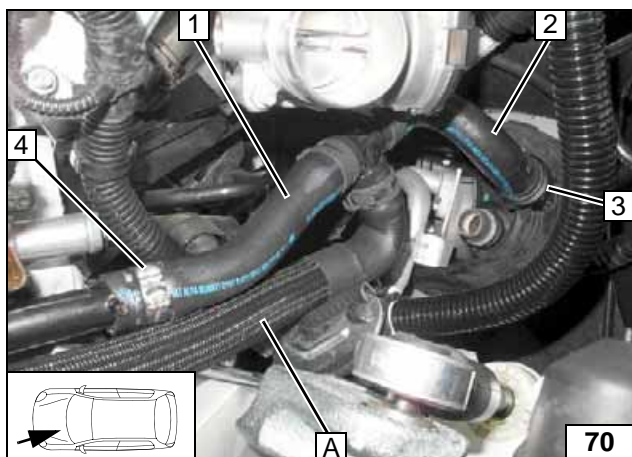

- 1 Hose section of engine inlet
- 2 Hose section of heat exchanger outlet
- 3 Coupling piece of heat exchanger outlet
- 4 Original vehicle clamp

Connection on engine inlet / heat exchanger outlet

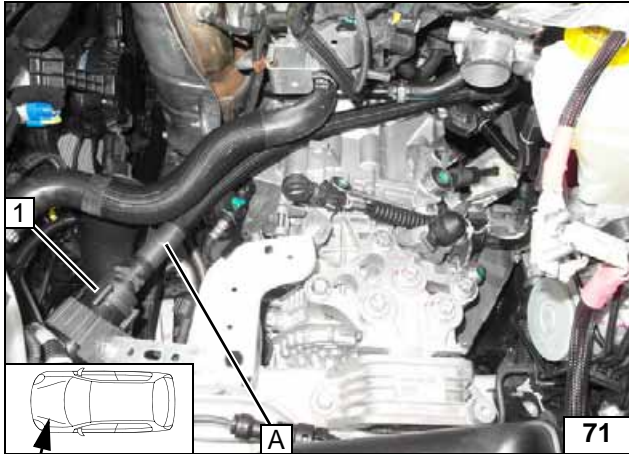

1 Circulating pump

Connect-
ing circulat-
ing pump

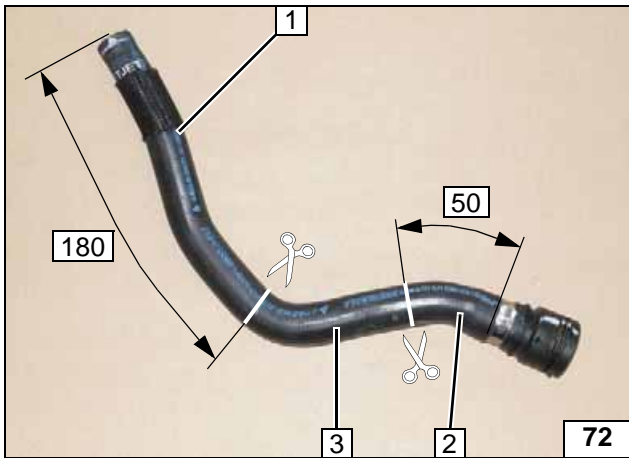

1 Hose section of engine outlet
2 Hose section of heat exchanger inlet
3 Discard section

Cutting
point

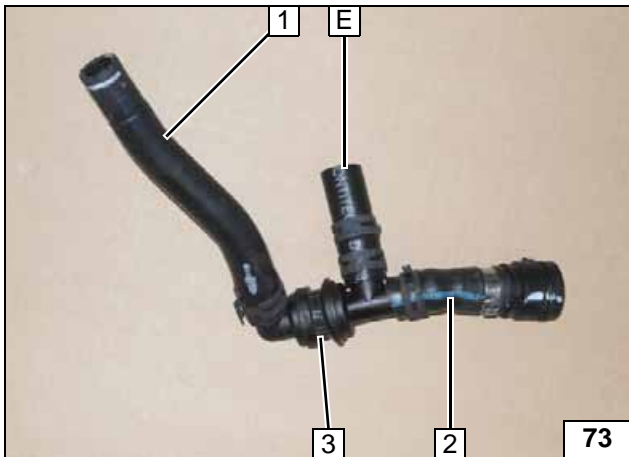

1 Hose section of engine outlet
2 Hose section of heat exchanger inlet
3 Check valve

Installing
check valve

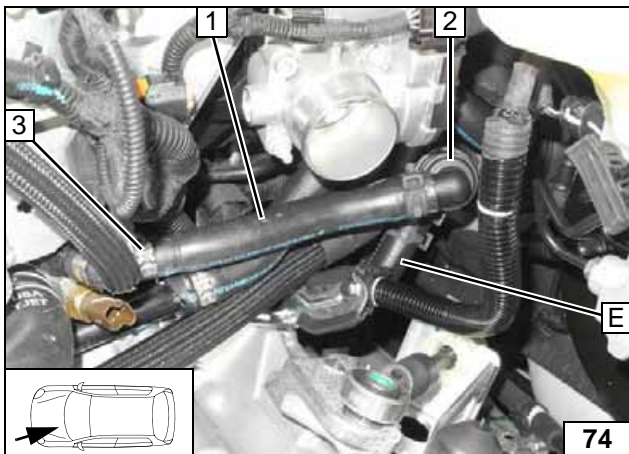

Mount coupling piece on connection piece of heat exchanger inlet (hidden by check valve 2).



1 Hose section of engine outlet
3 Original vehicle clamp

Connec-
tion of en-
gine outlet /
heat ex-
changer in-
let

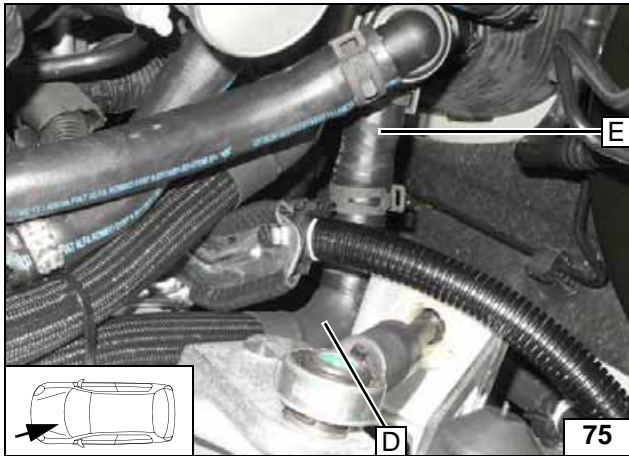

Connec-
tion of hose
D

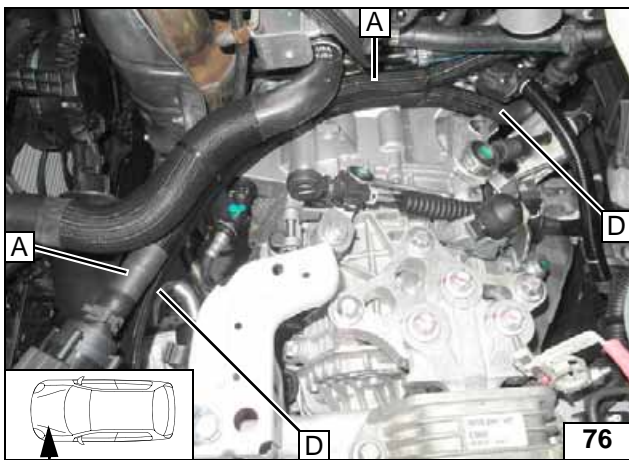

Align hose and fasten with cable tie. Ensure sufficient distance from neighbouring components, correct if necessary.



Routing in
engine compart-
ment

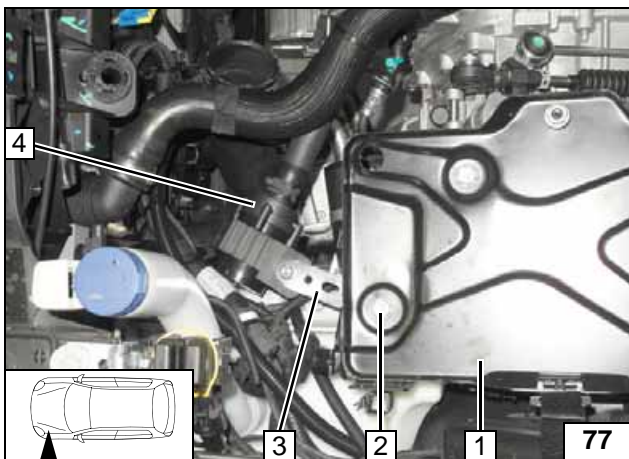

Mount perforated bracket 3 together with battery carrier 1 as shown.

- 2 Original vehicle M8 bolt
- 4 Align circulating pump



Securing
circulating
pump

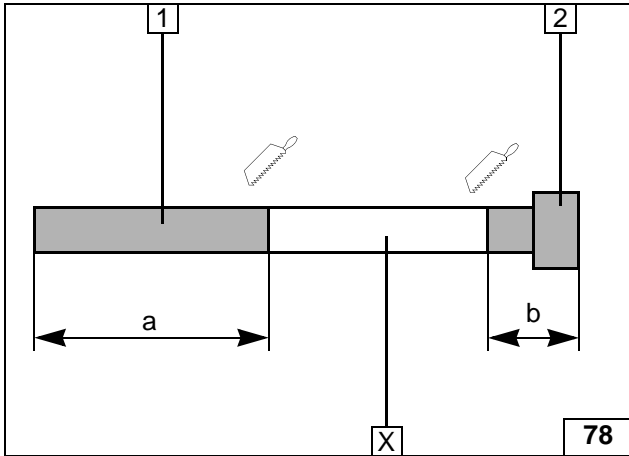
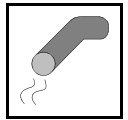

Exhaust Gas

Discard section X.

- 1 Exhaust pipe
a = 150
- 2 Exhaust end section
b = 50

Preparing exhaust pipe

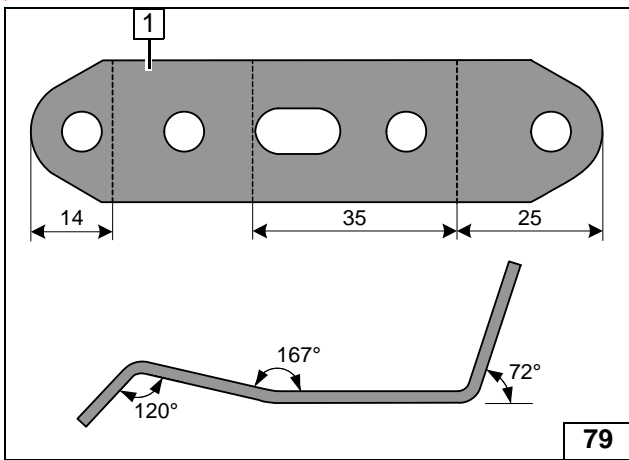

- 1 Perforated bracket

Preparing perforated bracket

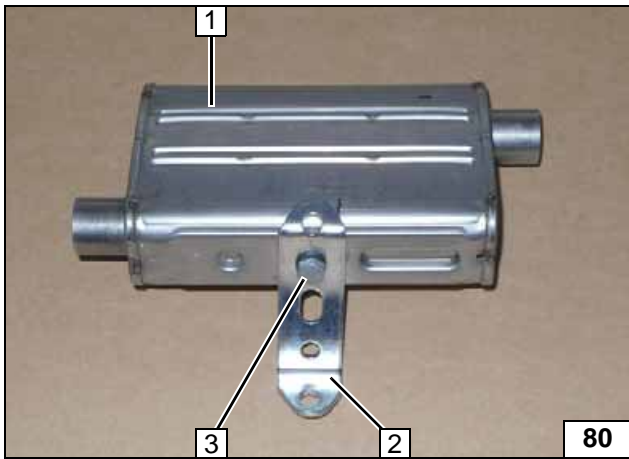

- 1 Silencer
- 2 Perforated bracket
- 3 M6x16 bolt, spring lockwasher

Installing perforated bracket

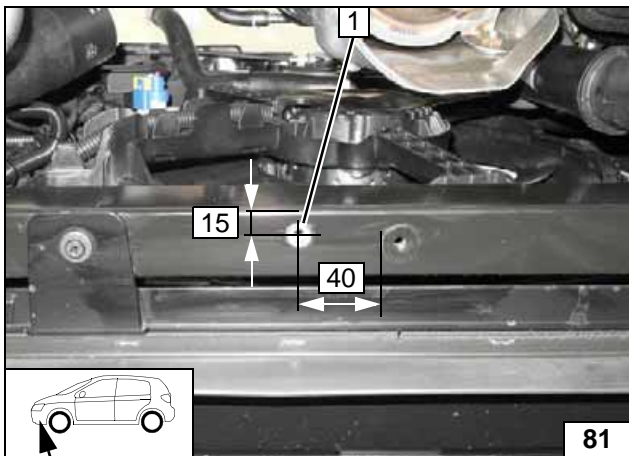

- 1 9.1 mm dia. hole; rivet nut

Installing rivet nut

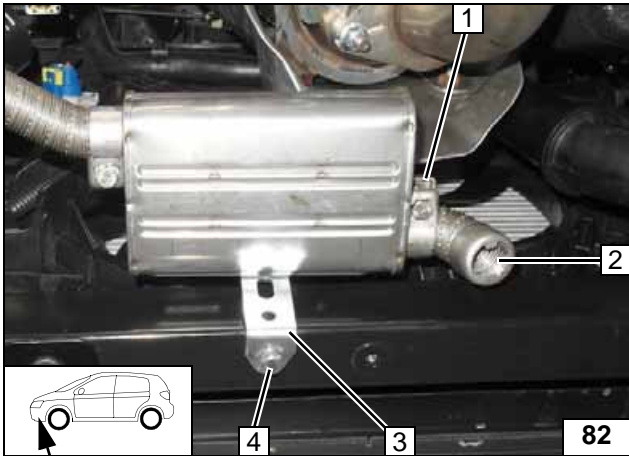
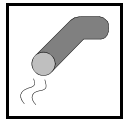

- 1 Hose clamp
- 2 Exhaust end section
- 3 Perforated bracket
- 4 M6x20 bolt, spring lockwasher

Installing silencer and exhaust end section

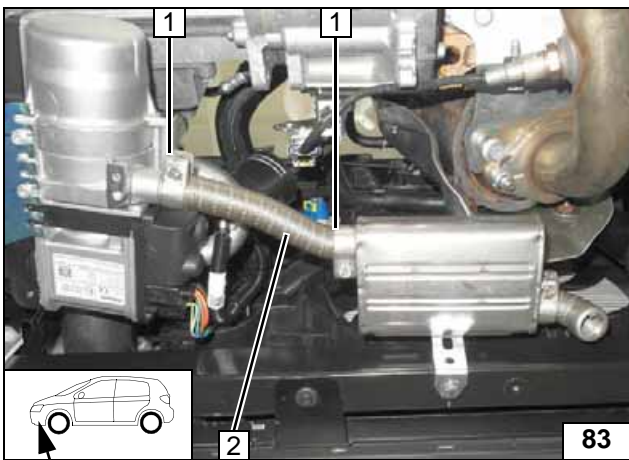

Ensure sufficient distance from neighbouring components, correct if necessary.

- 1 Hose clamp [2x]
- 2 Exhaust pipe

Installing exhaust pipe

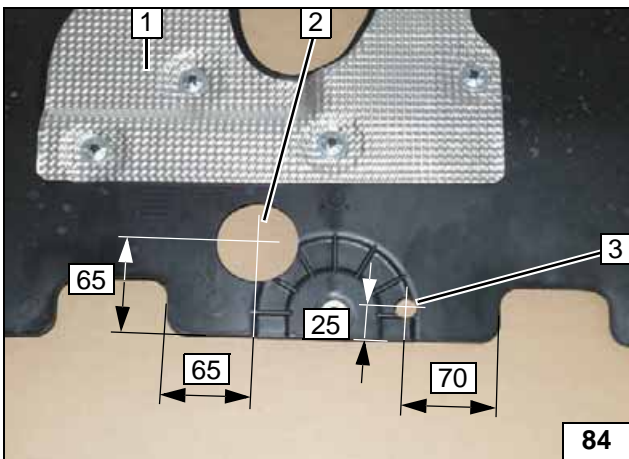

- 1 Under-ride protection
- 2 60 mm dia. hole
- 3 16 mm dia. hole

Holes in under-ride protection

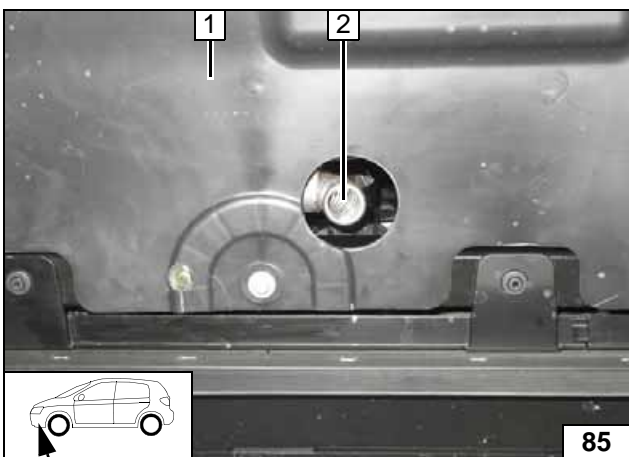

Mount under-ride protection 1. Align exhaust end section 2 with the centre of the hole and flush with under-ride protection 1.

Mounting under-ride protection



Final Work

WARNING!

Mount removed parts in reverse order. Check all hoses, clamps and all electrical connections for firm seating. Insulate all loose wires and tie back.

Only use manufacturer-approved coolant. Spray the heater components with anti-corrosion wax (Tectyl 100K, Order No. 111329).



- **Connect the battery.**
- **Fill and bleed the coolant circuit according to the vehicle manufacturer's specifications.**
- **Program MultiControl CAR, teach telestart transmitter.**
- **Make settings on A/C control panel according to the "Operating Instructions for the End Customer".**
- **Place the "Switch off parking heater before refuelling" caution label in the area of the filler neck.**
- **For initial startup and function check, please see installation instructions**

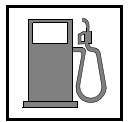

Template for Fuel Standpipe

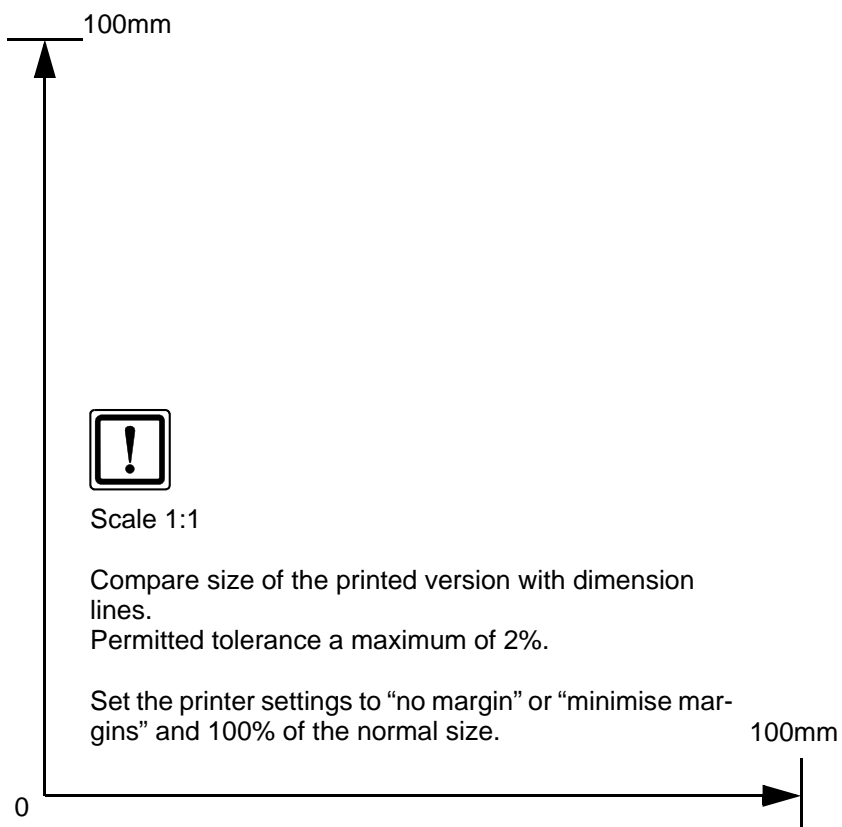

Operating Instructions for Manual Air-Conditioning

Please remove page and add to the vehicle operating instructions.

Note:

We recommend matching the heating time to the driving time.
 Heating time = driving time

Example:

For a driving time of approx. 20 min. (in one direction), we recommend not exceeding a switch-on time of 20 min.

Passenger compartment monitoring, if installed, must be deactivated in addition to the vehicle settings for the heating operation.

For instructions on deactivation, please refer to the operating instructions of the vehicle.

Before parking the vehicle, make the following settings:

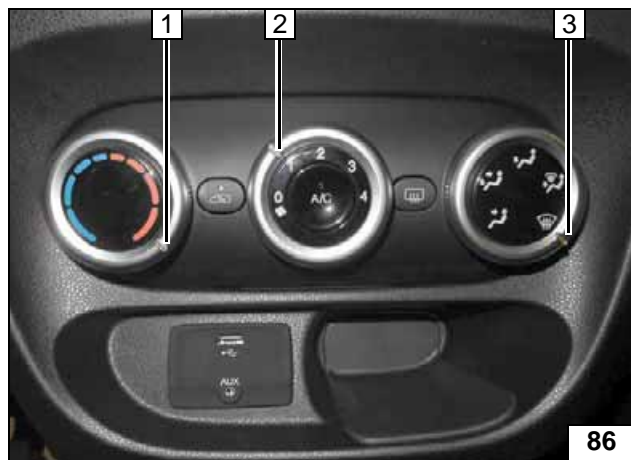

- 1 Set temperature to "max."
- 2 Set fan to level "1", or max. "2"
- 3 Air outlet onto windscreen

A/C control panel

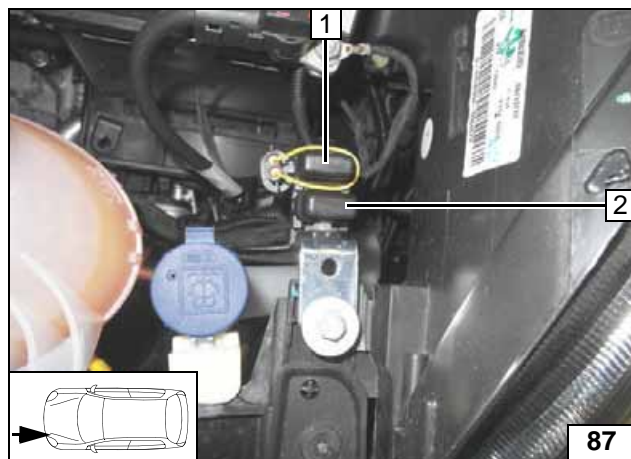

- 1 20A heater fuse F1
- 2 30A main fuse F2 of passenger compartment

Engine compartment fuses

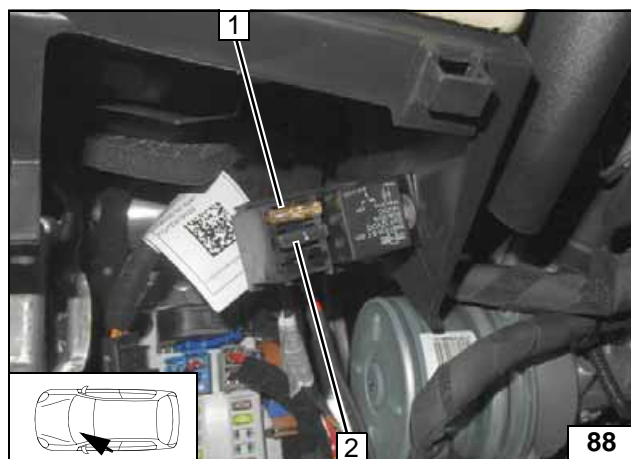

- 1 25A fan fuse F4
- 2 1A fuse F3 of heater control

Passenger compartment fuses



Operating Instructions for Automatic Air-Conditioning

Please remove page and add to the vehicle operating instructions.

Note:

We recommend matching the heating time to the driving time.
Heating time = driving time

Example:

For a driving time of approx. 20 min. (in one direction), we recommend not exceeding a switch-on time of 20 min.

Passenger compartment monitoring, if installed, must be deactivated in addition to the vehicle settings for the heating operation.

For instructions on deactivation, please refer to the operating instructions of the vehicle.

Before parking the vehicle, make the following settings:



Note:

The fan speed need not be preset!

- 1 Set temperature to "32.0°C"
- 2 Air outlet faces "upward"



A/C control panel

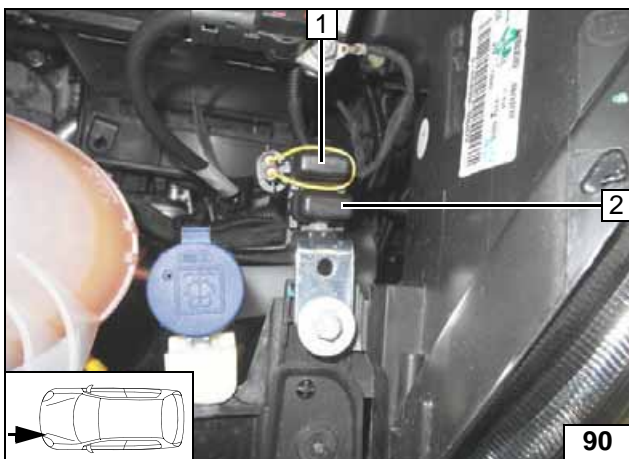

- 1 20A heater fuse F1
- 2 30A main fuse F2 of passenger compartment

Engine compartment fuses

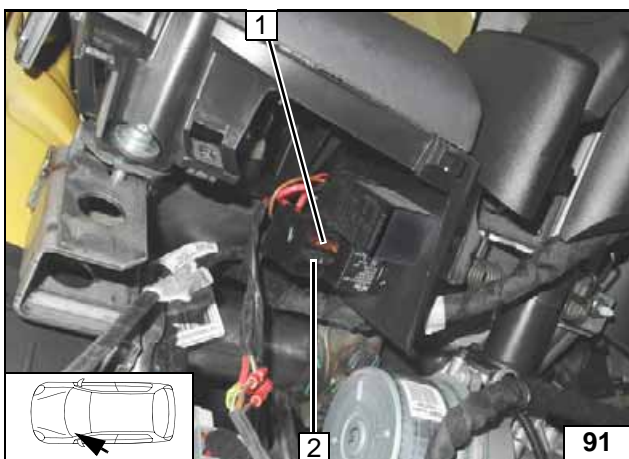

- 1 5A fan fuse F4
- 2 1A fuse F3 of heater control

Passenger compartment fuses

