

Water Heater

Thermo Top Evo Parking Heater



Installation Documentation

Citroen Cactus

Validity

Manufacturer	Model	Type	EG-BE No. / ABE
Citroen	Cactus	0	e2 * 2007 / 46 * 0440 * ...

Motorisation	Fuel	Transmission type	Output in kW	Displacement in cm ³	Engine code
1.2 PureTech	Petrol	5-speed SG	55	1199	HM01
1.2 PureTech	Petrol	5-speed SG	81	1199	HN01
1.6 BlueHdi	Diesel	5-speed SG	73	1560	BH02
1.6 HDI	Diesel	AG	68	1560	9H06

SG = manual transmission

AG = automatic transmission

From Model Year 2015

Left-hand drive vehicle

Verified equipment variants: Manual / automatic air-conditioning system

Front fog lights

Daytime running lights

Start / Stop

Total installation time: approx. 10 hours

Citroen Cactus

Table of Contents

Validity	1	Preparing Installation Location	16
Necessary Components	2	Preparing Heater	17
Installation Overview	2	Installing Heater	18
Information on Total Installation Time	2	Fuel	20
Information on Operating and Installation Instructions	3	Coolant Circuit	26
Information on Validity	4	Combustion Air	35
Technical Information	4	Exhaust Gas	36
Explanatory Notes on Document	4	Final Work	38
Preliminary Work	5	Drilling Template	40
Heater Installation Location	5	Template for Bracket A	41
Preparing Electrical System	6	Template for Bracket B	42
Electrical System	8	Template for Fuel Standpipe	43
Wiring Harness Routing	9	Operating Instructions for Manual Air-Conditioning	44
Dismantling Instructions for the Passenger Compartment	9	Operating Instructions for Automatic A/C	45
Fan Controller	11		
MultiControl CAR Option	14		
Remote Option (Telestart)	14		
Thermo Call TC3 Option	15		

Necessary Components

- Basic delivery scope of *Thermo Top Evo* based on price list
- Installation kit for Citroen Cactus 2015 Petrol and Diesel: **1323437A**
- To be ordered additionally from Citroen: 2x Citroen retaining clamps, Order No.: **1609267180**
- Heater control in accordance with price list and upon consultation with end customer
- In case of Telestart, indicator lamp in accordance with price list and in consultation with end customer

Installation instructions:

- Arrange for the vehicle to be delivered with the tank only about $\frac{1}{4}$ full.
- The installation location of the push button in case of Telestart or Thermo Call should be confirmed with the end customer.
- Depending on the available space and manufacturer's instructions, we recommend the use of a vehicle battery with more electrical capacity.
- To avoid incorrect entries in the engine control unit, the BSI must be coded by engine version 1.2 petrol 81KW. More information in paragraph "Final Work"!

Installation Overview

Legend:

1. Heater
2. Engine compartment fuse holder
3. Passenger compartment relay and fuse holder
4. PWM-Gateway
5. K2 relay
6. Circulating pump
7. MultiControl CAR
8. Metering pump

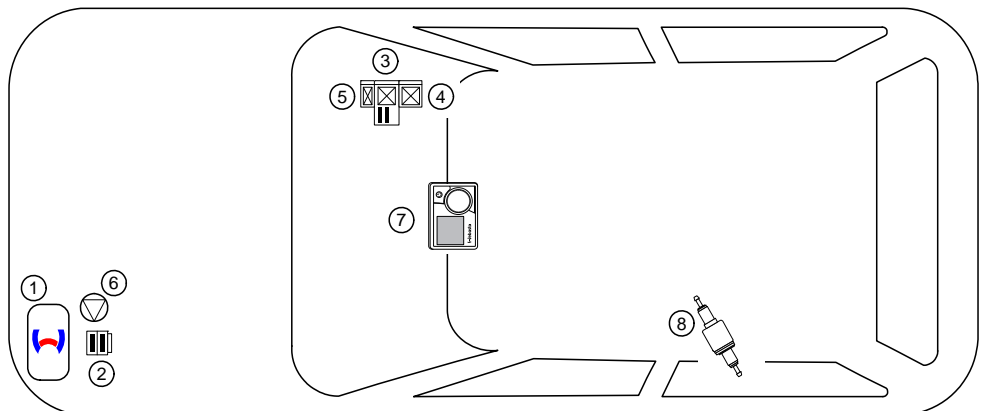

Information on Total Installation Time

The total installation time includes the time needed for mounting and demounting of the vehicle-specific components, the heater specific installation time and all other times required for the system integration and initial start-up of the heater.

The total installation time may vary for vehicle equipment other than provided.

Information on Operating and Installation Instructions

1 Important notes (not complete)

1.1 Installation and repair



The improper installation or repair of Webasto heating and cooling systems can cause fire or the leakage of deadly carbon monoxide, leading to serious injury or death.



To install and repair Webasto heating and cooling systems you need to have completed a special company training course and have the appropriate technical documentation, special tools and special equipment.



Installation and repair may ONLY be carried out by persons trained and certified in a Webasto training course. NEVER try to install or repair Webasto heating or cooling systems if you have not completed a Webasto training course, you do not have the necessary technical skills and you do not have the technical documentation, tools and equipment available to ensure that you can complete the installation and repair work properly.

Only use genuine Webasto parts. See the Webasto air and water heaters accessories catalogue for this purpose.

1.2 Operation

To ensure safe operation, we recommend having the heater checked every two years by an authorised Webasto dealer, especially when used over a long period and/or under extreme environmental conditions.

Do not operate the heater in closed rooms due to the danger of poisoning and suffocation.

Always switch off the heater before refuelling.

The heater may only be used with the prescribed fuel Diesel (DIN EN 590) or petrol (DIN EN 228).

The heater may not be cleaned with a high-pressure cleaner.

1.3 Please note

ALWAYS follow all Webasto installation and operating instructions and observe all warnings.

To become familiar with and understand all functions and properties of the heater, the operating instructions must be read carefully and observed at all times.

For proper, safe installation and repair work, the installation instructions with all warnings and safety information must be carefully read and observed at all times. Please always contact a workshop authorised by Webasto for all installation and repair work.

Important

Webasto shall assume no liability for defects, damage and injuries resulting from a failure to observe the installation, repair and operating instructions of the information contained in them.

This liability exclusion particularly applies to improper installations and repairs, installations and repairs by untrained persons or in the case of a failure to use genuine spare parts.

The liability due to culpable disregard to life, limb or health and due to damage or injuries caused by a wilful or reckless breach of duty remain unaffected, as does the obligatory product liability.

Installation should be carried out according to the general, standard rules of technology. Unless specified otherwise, fasten hoses, lines and wiring harnesses to original vehicle lines and wiring harnesses using cable ties. Insulate loose wire ends and tie back. Connectors on electronic components have to audibly click into place during installation.

Sharp edges should be fitted with rub protection. Spray unfinished body areas, e.g. drilled holes, with anti-corrosion wax (Tectyl 100K, Order No. 111329).

Observe the instructions and guidelines of the respective vehicle manufacturer for demounting and mounting vehicle specific components!

The initial startup is to be executed with the Webasto Thermo Test Diagnosis.

When installing a programmable control module (e.g. a PWM Gateway), the corresponding settings must be checked or adjusted.

2 Statutory regulations governing installation

Guidelines	TT-Evo
Heating Directive ECE R122	E1 00 0258
EMC Directive ECE R10	E1 04 5627

Note

The regulations of these guidelines are binding in the scope of the Directive 70/156/EEC and/or 2007/46/EC (for new vehicle models from 29/04/2009) and should also be observed in countries in which there are no special regulations.

Important

Failure to follow the installation instructions will result in the invalidation of the type approval for the heater and therefore invalidation of the general **homologation of the vehicle**.

Note

The heater is licensed in accordance with paragraph 19, section 3, No. 2b of the StVZO (German Road Traffic Licensing Authority).

2.1 Excerpt from the directive 122 (heater) section 5 for the installation of the heater.

Beginning of excerpt.

ANNEX VII

REQUIREMENTS FOR COMBUSTION HEATERS AND THEIR INSTALLATION

1. GENERAL REQUIREMENTS

1.7.1. A clearly visible tell-tale in the operator's field of view shall inform when the combustion heater is switched on or off.

2. VEHICLE INSTALLATION REQUIREMENTS

2.1. Scope

2.1.1. Subject to paragraph 2.1.2. combustion heaters shall be installed according to the requirements of this Annex.

2.1.2. Vehicles of category O having liquid fuel heaters are deemed to comply with the requirements of this Annex.

2.2. Positioning of heater

2.2.1. Body sections and any other components in the vicinity of the heater must be protected from excessive heat and the possibility of fuel or oil contamination.

2.2.2. The combustion heater shall not constitute a risk of fire, even in the case of overheating. This requirement shall be deemed to be fulfilled if the installation ensures an adequate distance to all parts and suitable ventilation, by the use of fire resistant materials or by the use of heat shields.

2.2.3. In the case of M2 and M3 vehicles, the heater must not be positioned in the passenger compartment. However, an installation in an effectively sealed envelope which also complies with the conditions in paragraph 2.2.2 may be used.

2.2.4. The label referred to in paragraph 1.4 or a duplicate, must be positioned so that it can be easily read when the heater is installed in the vehicle.

2.2.5. Every reasonable precaution should be taken in positioning the heater to minimise the risk of injury and damage to personal property.

2.3. Fuel supply

2.3.1. The fuel filler must not be situated in the passenger compartment and must be provided with an effective cap to prevent fuel spillage.

2.3.2. In the case of liquid fuel heaters, where a supply separate to that of the vehicle is provided, the type of fuel and its filler point must be clearly labelled.

2.3.3. A notice, indicating that the heater must be shut down before refuelling, must be affixed to the fuelling point. In addition a suitable instruction must be included in the manufacturer's operating manual.

2.4. Exhaust system

2.4.1. The exhaust gas outlet must be located so as to prevent emissions from entering the vehicle through ventilators, heated air inlets or opening windows.

2.5. Combustion air inlet

2.5.1. The air for the combustion chamber of the heater must not be drawn from the passenger compartment of the vehicle.

2.5.2. The air inlet must be so positioned or guarded that blocking by rubbish or luggage is unlikely.

2.6. Heating air inlet

2.6.1. The heating air supply may be fresh or recirculated air and must be drawn from a clean area not likely to be contaminated by exhaust fumes emitted either by the propulsion engine, the combustion heater or any other vehicle source.

2.6.2. The inlet duct must be protected by mesh or other suitable means.

2.7. Heating air outlet

2.7.1. Any ducting used to route the hot air through the vehicle must be so positioned or protected that no injury or damage could be caused if it were to be touched.

2.7.2. The air outlet must be so positioned or guarded that blocking by rubbish or luggage is unlikely.

End of excerpt.

In multilingual versions the German language is binding.

Citroen Cactus

Information on Validity

This installation documentation applies to Citroen Cactus Petrol and Diesel vehicles - for validity, see page 1 - from model year 2015 and later, assuming technical modifications to the vehicle do not affect installation, any liability claims excluded. Depending on the vehicle version and equipment, modifications may be necessary during installation with respect to this installation documentation.

Vehicle and engine types, equipment variants and other specifications not listed in this installation documentation have not been tested. However, installation according to this installation documentation may be possible.

Technical Information

Special Tools

- Hose clamp pliers for auto-tightening hose clamps
- Hose clamp pliers for Clic hose clamps of type W
- Wire stripper 0.2 - 6mm²
- Crimping pliers for cable lug / tab connector 0.5 - 6mm²
- Torque wrench for 2.0 - 10 Nm
- Hose clamping pliers
- Metric thread-setter kit
- Webasto Thermo Test Diagnosis with current software

Dimensions

- All dimensions are in mm.

Tightening torque values

- Tightening torque values of 5x13 heater bolts and 5x11 heater stud bolts = 8Nm.
- Tightening torque values of 5x15 water connection piece retaining plate bolt = 7Nm.
- Tighten other bolt connections in accordance with manufacturer's instructions or in accordance with state-of-the-art-technology.

Explanatory Notes on Document

You will find an identification mark on the outside top right corner of the page in question to provide you with a quick overview of the individual working steps.

Special features are highlighted using the following symbols:

Mechanical System



Specific risk of injury or fatal accidents.



Electrical System



Specific risk due to electrical voltage



Coolant Circuit



Specific risk of damage to components.



Combustion Air



Specific risk of fire and explosion.



Fuel



Reference to general installation instructions of the Webasto components or to the manufacturer's vehicle-specific documents.



Reference to a special technical feature.



Exhaust Gas



The arrow in the vehicle icon indicates the position on the vehicle and the viewing angle

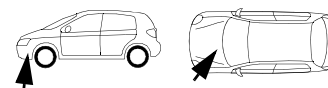

Software



Tightening torque according to the manufacturer's



Citroen Cactus

Preliminary Work

Vehicle

- Open the fuel tank cap.
- Ventilate the fuel tank.
- Close the fuel tank cap again.
- Depressurise the cooling system.
- Disconnect and completely remove the battery together with the carrier.
- Remove the bracket of the vacuum sensor on the brake booster.
- Remove the lower engine cover (if present).
- Remove the underride protection on the left (if present).
- Remove the left front wheel.
- Remove the left wheel well trim, detach it in the right front area.
- Unhook the Bowden cable of the bonnet lock from the latch.
- Remove the daytime running lights on the right and on the left.
- Remove the bumper trim.
- Detach the rear bench seat (clipped in).
- Remove the lower instrument panel trim on the driver's side (see the dismantling instructions for the passenger compartment).
- Remove the side trim of the centre console on the driver's side (see the dismantling instructions for the passenger compartment).
- Remove instrument panel trim on the right side (see the dismantling instructions for the passenger compartment).
- Remove the storage compartment underneath the glove compartment (see the dismantling instructions for the passenger compartment).

The following work should only be performed during the corresponding installation sequence:

- Open the tank-fitting service lid.
- Remove the fuel-tank sending unit in accordance with the manufacturer's instructions.

Heater

- Remove years that do not apply from the type and duplicate label.
- Attach the duplicate label (type label) in the appropriate place in the engine compartment.



Heater Installation Location

1 Heater

Installation location

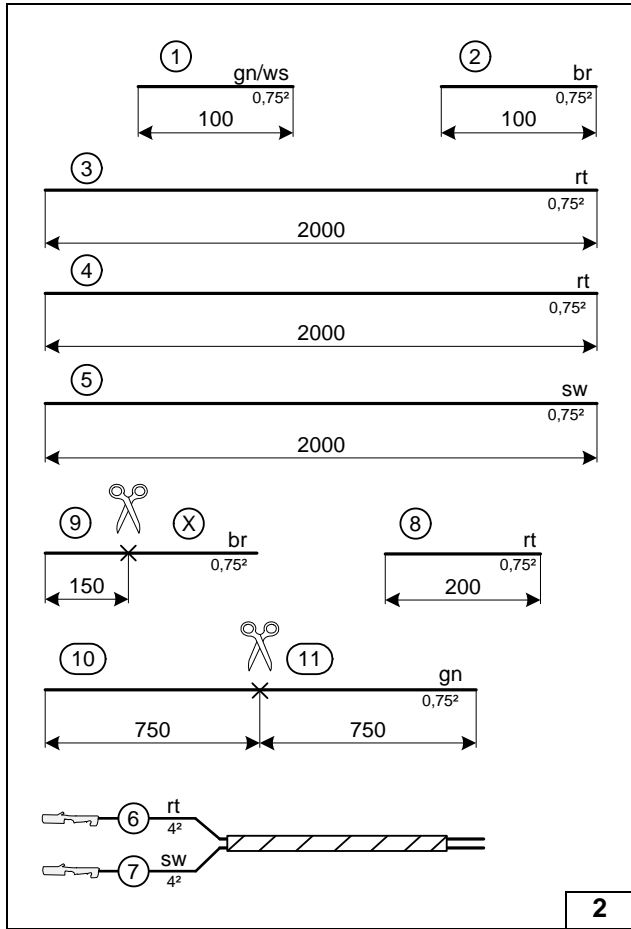
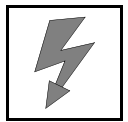

Preparing Electrical System

Wire sections retain their numbering throughout the entire document.

Produce all following electrical connections as shown in wiring diagram.

Discard section X.

Pull wire section ④ into 2000mm protective sleeving.

Pull wire sections ⑩ and ⑪ into 500mm protective sleeving!

- ⑥ Red (rt) wire of fan wiring harness
- ⑦ Black (sw) wire of fan wiring harness

Assigning / preparing wires

2

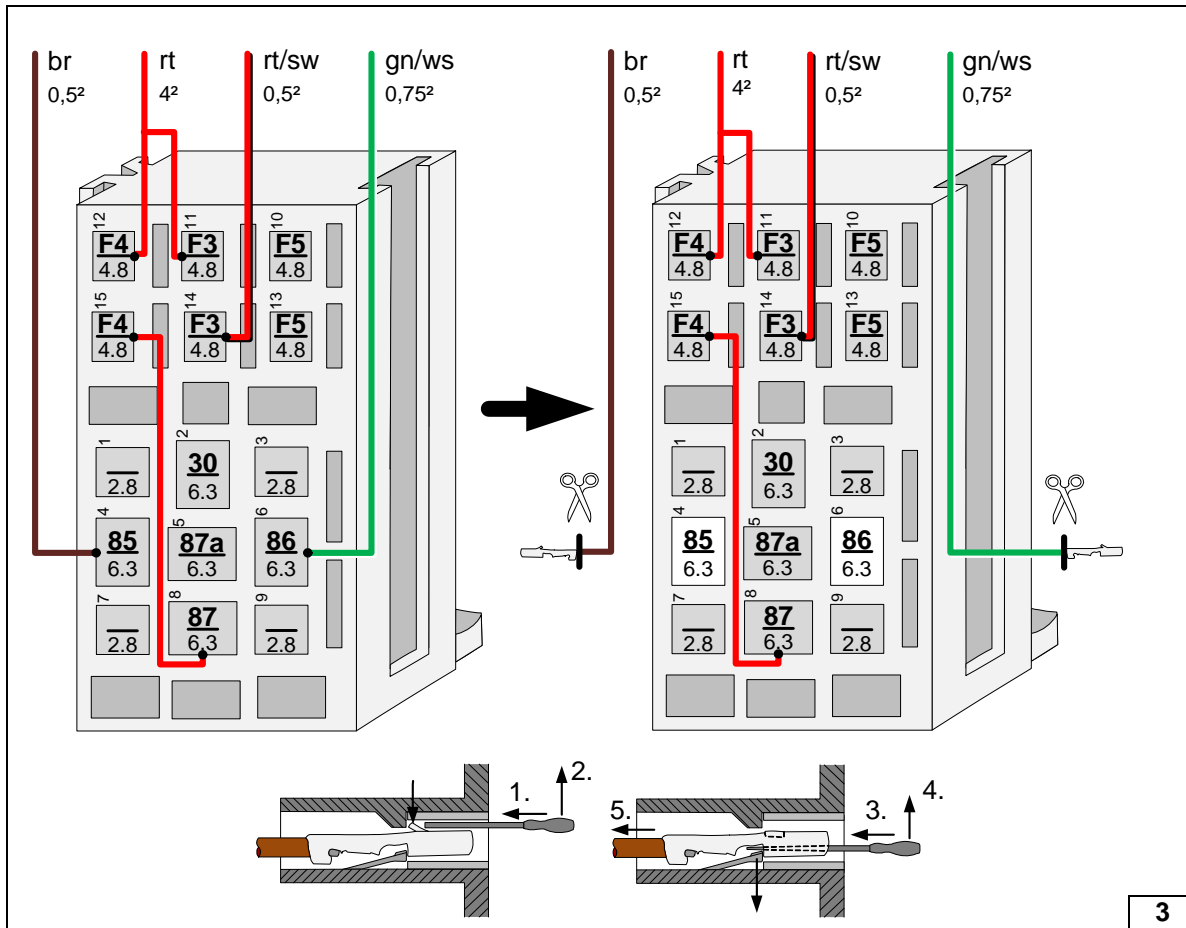

Preparing passenger compartment relay and fuse holder

3

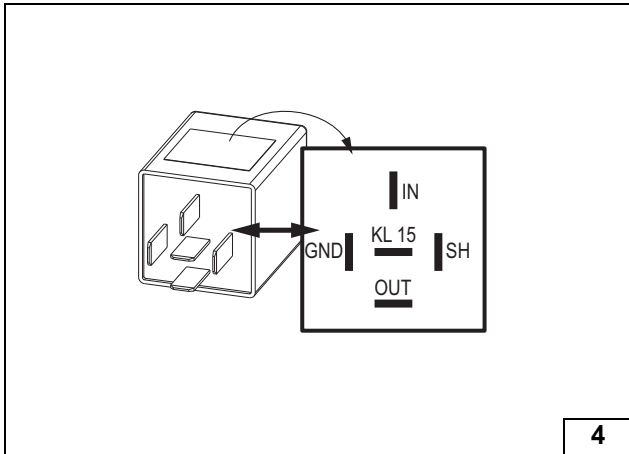
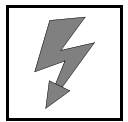

Check the PWM Gateway settings before start-up of the heater and adjust if necessary.

Settings:

Duty cycle: 70%
 Frequency: 400Hz
 Voltage: not relevant
 Function: Low-side

PWM-Gateway

4

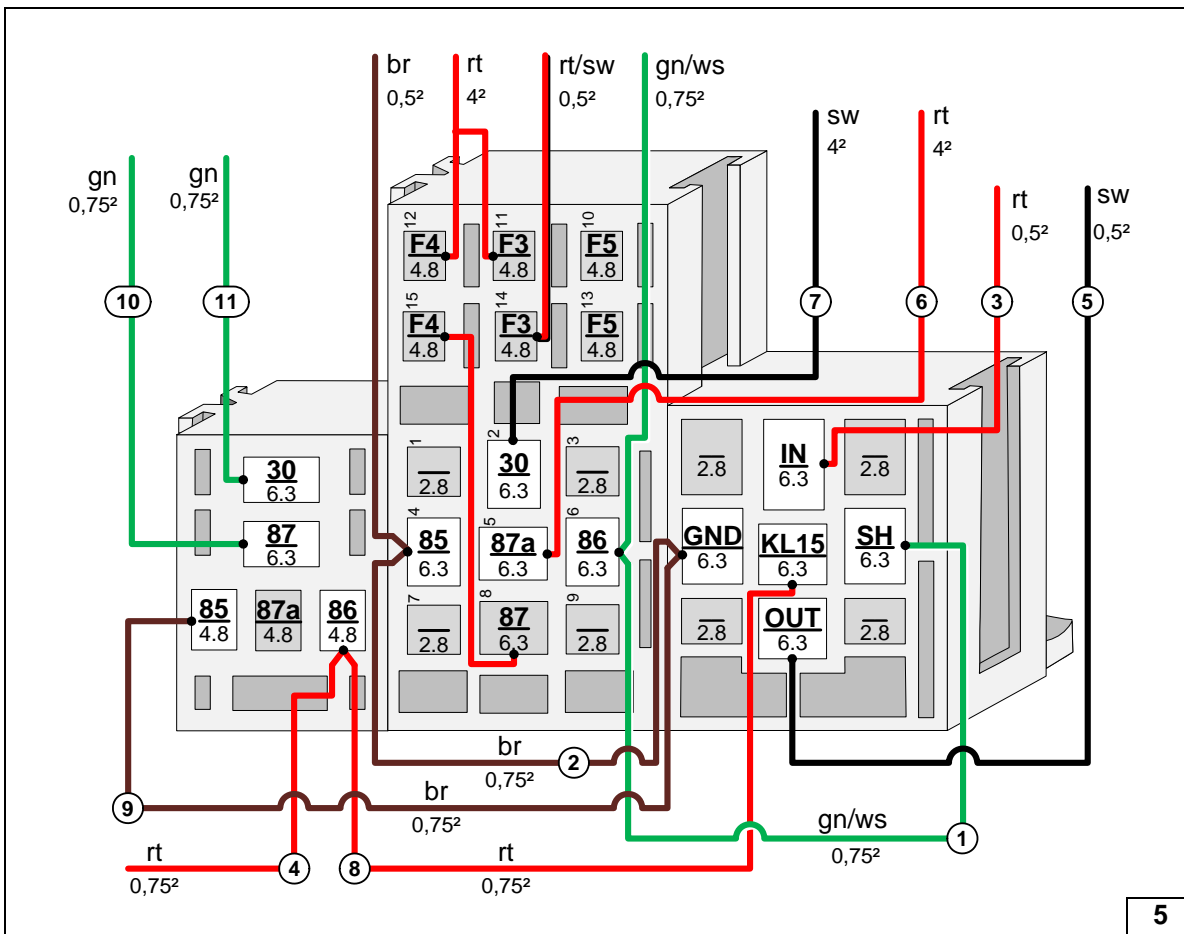

Interlocking PWM GW socket and K2 relay socket with passenger compartment relay and fuse holder, connecting wires

5

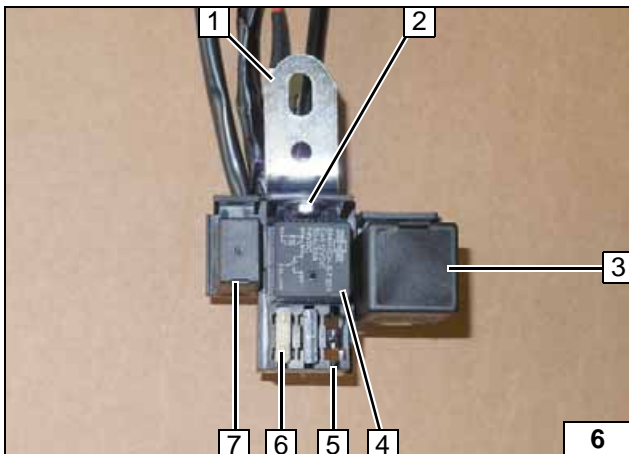

- 1 Angle bracket
- 2 M5x16 bolt, large diameter washer [2x], nut
- 3 PWM GW
- 4 K1 relay
- 5 Passenger compartment relay and fuse holder
- 6 25A fuse F4
- 7 K2 relay

Premounting passenger compartment relay and fuse holder

6



Electrical System

Positive wire

- 1 Positive wire on original vehicle positive distributor, if control unit 2 on battery not present
- 3 Positive wire on positive battery terminal, if control unit 2 on battery present

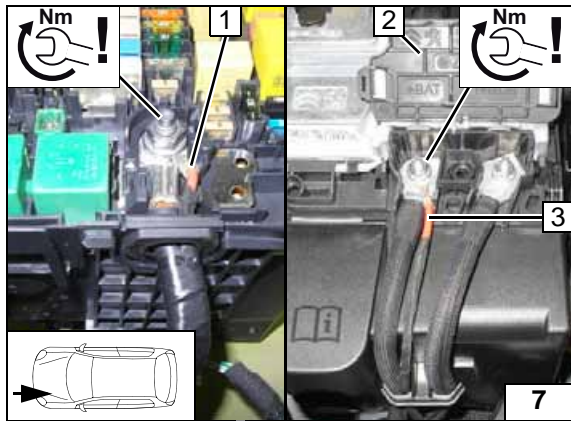

Wiring harness pass through of passenger compartment

See following page for wiring harness routing!

- 1 Protective rubber plug
- 2 Wiring harnesses of heater and heater control

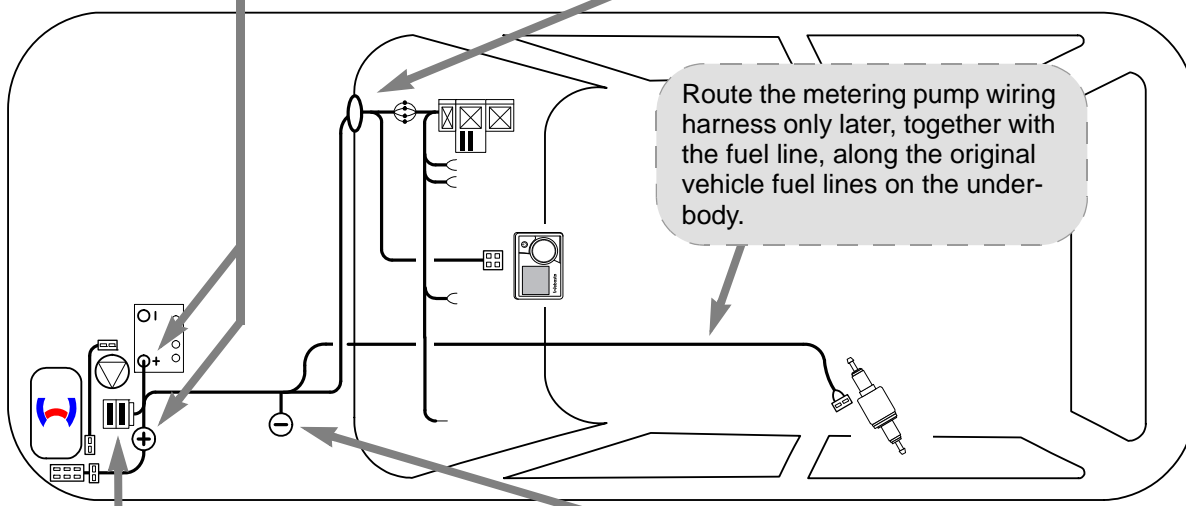
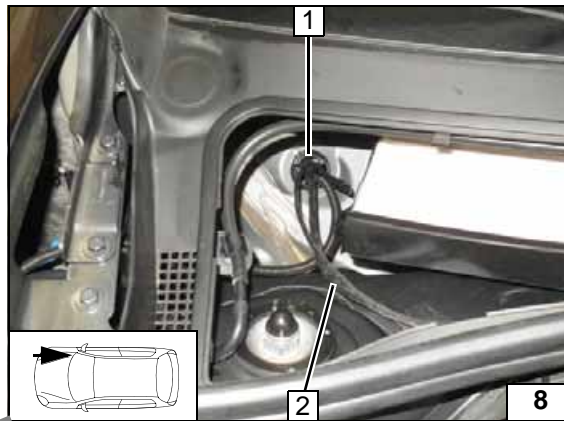

Wiring harness routing diagram

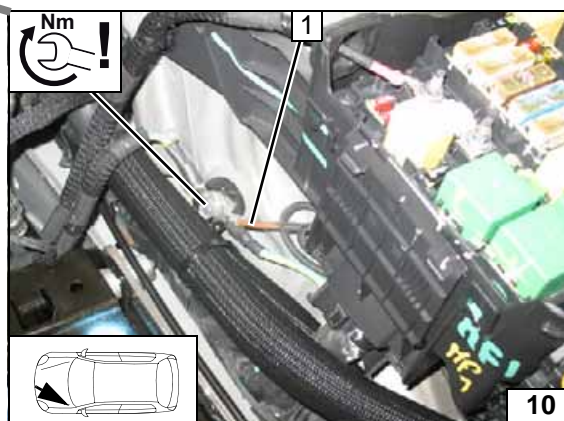
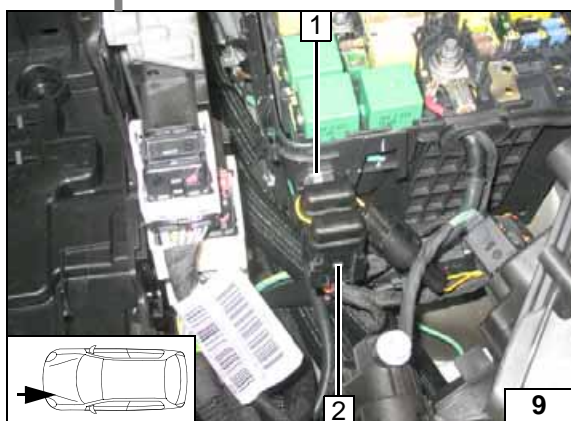

Engine compartment fuse holder

5.5 mm dia. hole at position 1. When drilling, watch components located behind!

- 1 M5x16 bolt, washer [2x], retaining plate of fuse holder, nut
- 2 Fuses F1-2

Earth wire

- 1 Earth wire on original vehicle earth support point

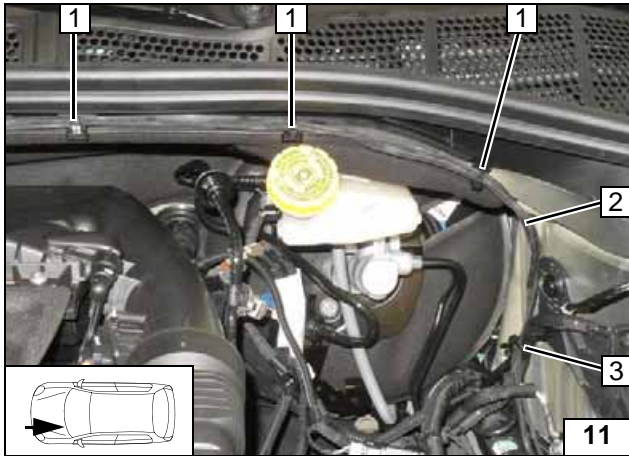

Wiring Harness Routing

- 1 Clip-type cable tie [3x] on the cowl panel side
- 2 Wiring harnesses of heater and heater control
- 3 Cable tie on original vehicle wiring harness

Routing in engine compartment

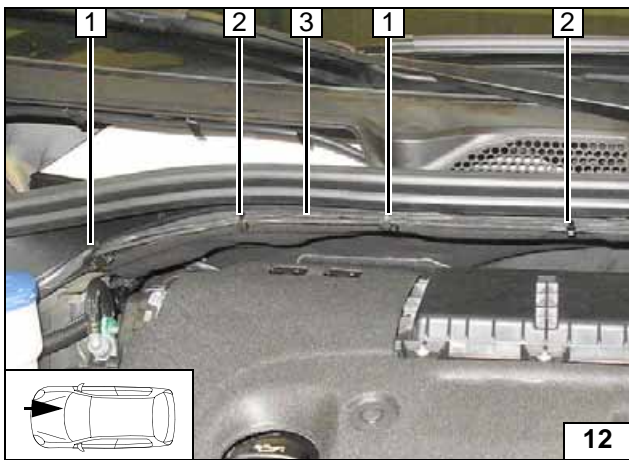

- 1 Clip-type cable tie [2x] on the cowl panel side
- 2 Cable tie [2x]
- 3 Wiring harnesses of heater and heater control

Routing in engine compartment



Route wiring harnesses of heater and heater control in position 1 into cowl panel.



Routing into cowl panel

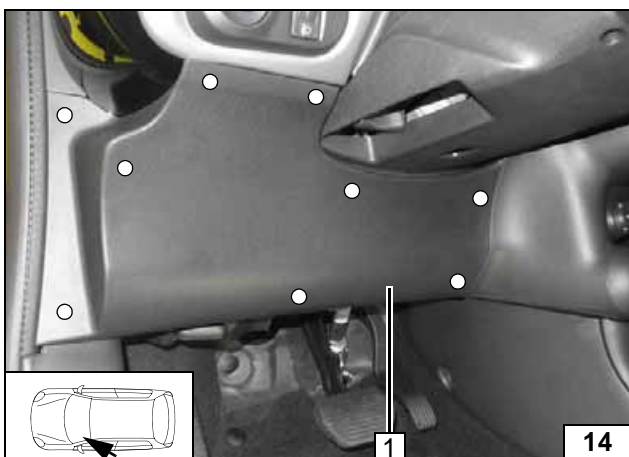

Dismantling Instructions for the Passenger Compartment

Detach lower instrument panel trim on the driver's side 1 and pull it back.

- Fastening clip [9x]



Removing lower instrument panel trim on the driver's side

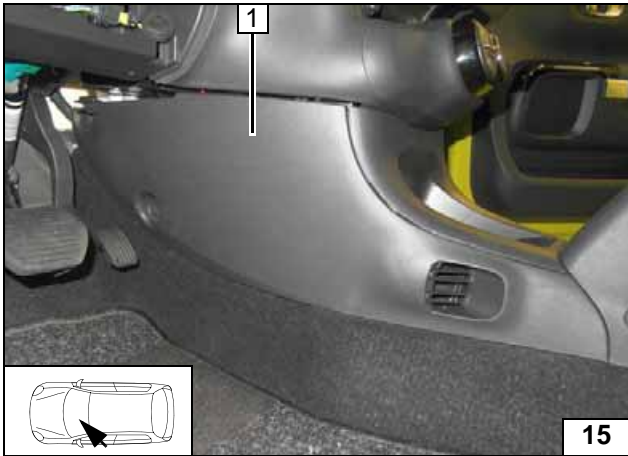
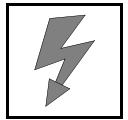

1 Side trim of centre console on the driver's side

Removing side trim of centre console on the driver's side

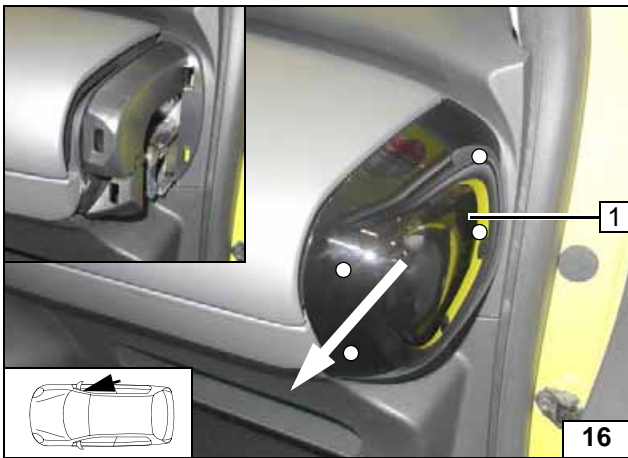

Only in case of Telearstart T100 HTM. Detach lateral instrument panel trim on the right 1 and pull it back.

- Fastening clip [4x]



Removing lateral instrument panel trim on the right

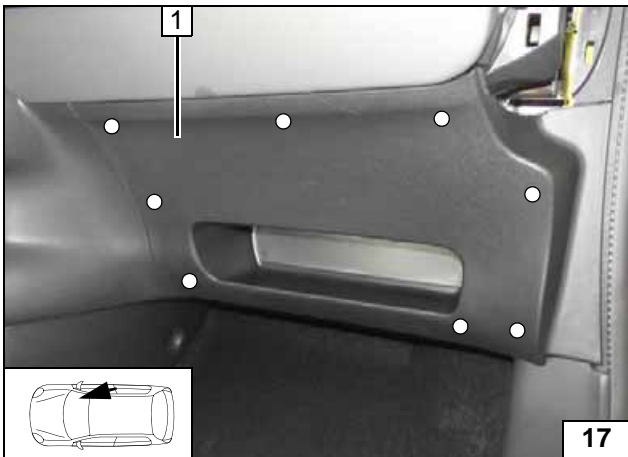

Detach the storage compartment under glove compartment 1 and pull it back.

- Fastening clip [8x]



Removing storage compartment under glove compartment

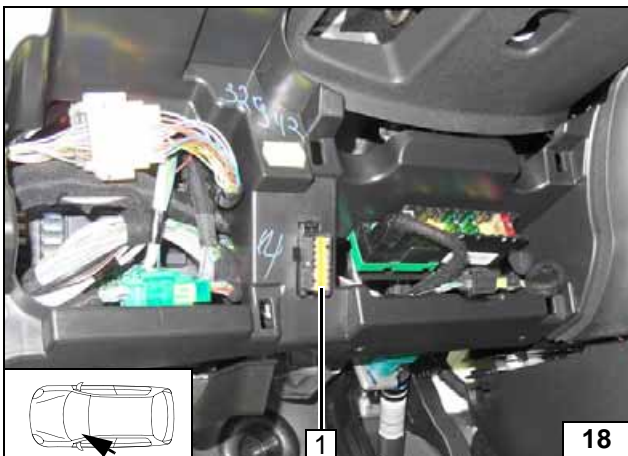

Unclip OBD socket outlet 1 and move it down.



Detaching OBD socket outlet



Fan Controller

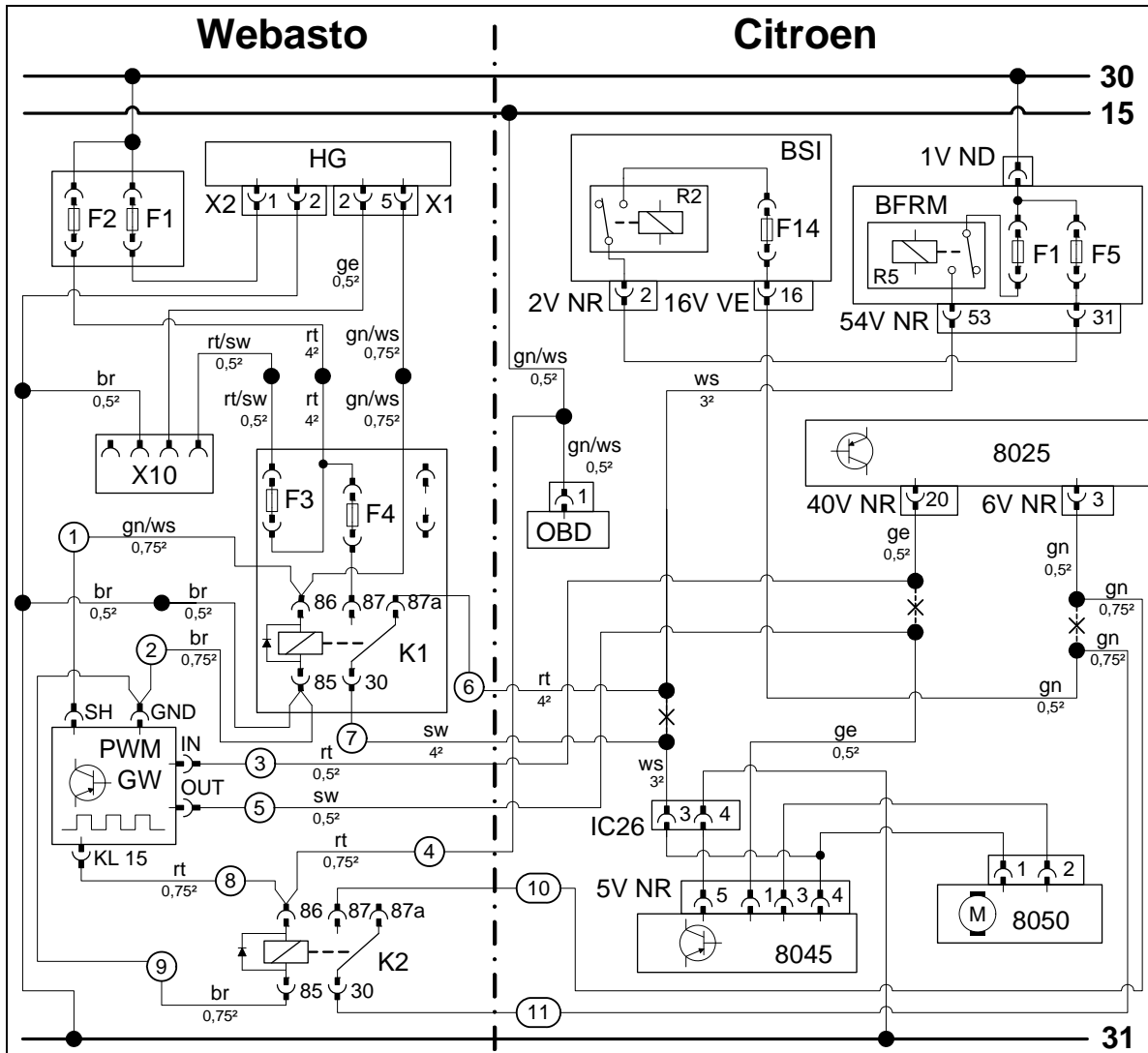

Wiring diagram

Webasto components		Vehicle components		Colours and symbols	
HG	TT-Evo heater	BSI	Central electrical box	rt	red
X1	6-pin heater connector	F14	Fuse	sw	black
X2	2-pin heater connector	R2	Relay	ge	yellow
F1	20A fuse	2V NR	2-pin connector BSI	gn	green
F2	30A fuse	16V VE	16-pin connector BSI	br	brown
X10	4-pin connector of heater control	BFRM	Engine compartment fuse and relay carrier	ws	white
F3	1A fuse	F1	Fuse		
F4	25A fuse	F5	Fuse		
K1	Fan relay	R5	Relay		
PWM-GW	Pulse width modulator	1V ND	1-pin connector BFRM		
K2	Additional relay	54V NR	54-pin connector BFRM		
		8025	A/C control unit		
		40V NR	40-pin connector 8025		
		6V NR	6-pin connector 8025		
		OBD	Socket outlet		
		IC26	2-pin connector		
		8050	Fan motor		
		8045	Fan controller	X	Cutting point
		5V NR	5-pin connector 8045		Wiring colours may vary.
Settings of PWM GW:					
	Duty cycle: 70%				
	Frequency: 400Hz				
	Voltage: not relevant				
	Function: Low-side				

Legend

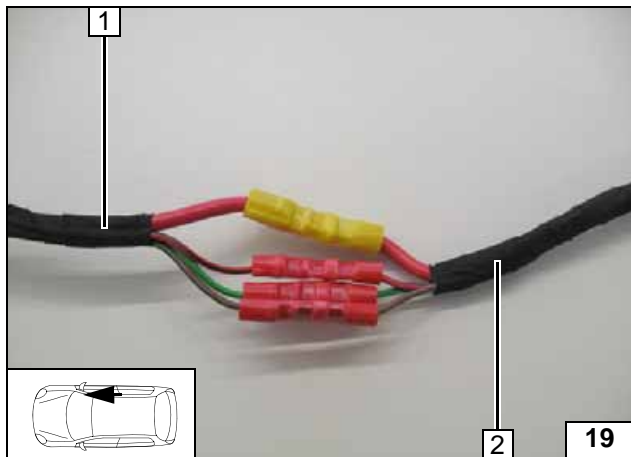

- 1 Wiring harness of passenger compartment relay and fuse holder
- 2 Wiring harness of heater

Connecting same colour wires of wiring harnesses

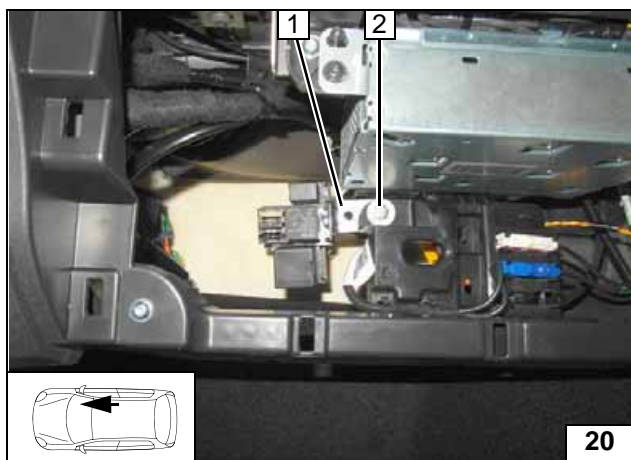

- 1 Angle bracket
- 2 M6x20 bolt, large diameter washer, flanged nut on existing hole

Installing passenger compartment relay and fuse holder

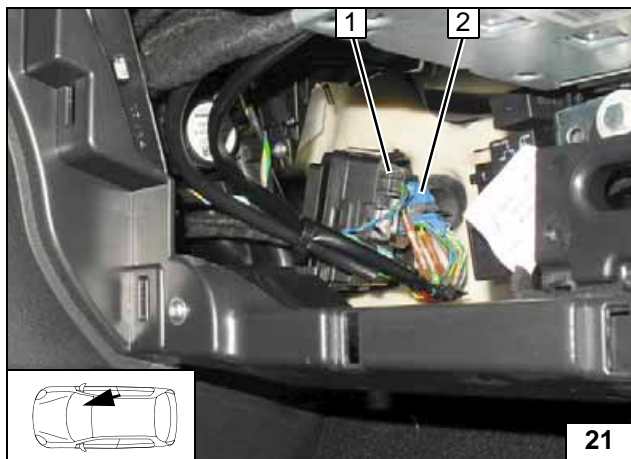

- 1 Connector 6V NR
- 2 Connector 40V NR

View of A/C control unit connector

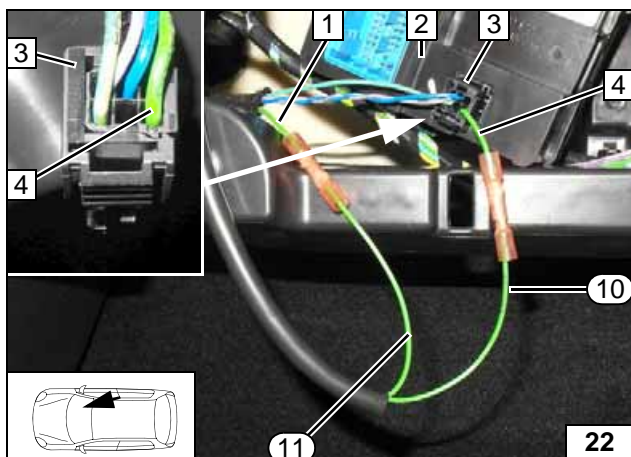

- 1 Green (gn) wire from BSI (delayed)
- 2 A/C control unit
- 3 Connector 6V NR of A/C control unit
- 4 Green (gn) wire of connector 6V NR, pin 3
- ⑩ Green (gn) wire from K2/87
- ⑪ Green (gn) wire from K2/30

Connecting A/C control unit

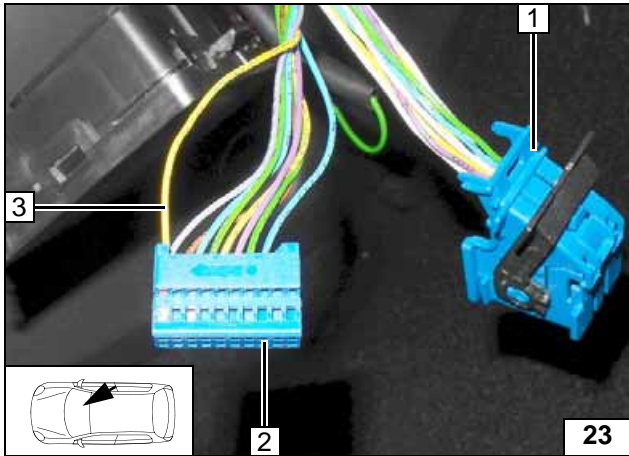
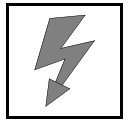

Disconnect connector 40V NR 1 from A/C control unit and disassemble!

- 2 Blue contact strip of connector 40V NR, pin 1-20
- 3 Yellow (ge) wire, pin 20

Connector 40V NR of A/C control unit

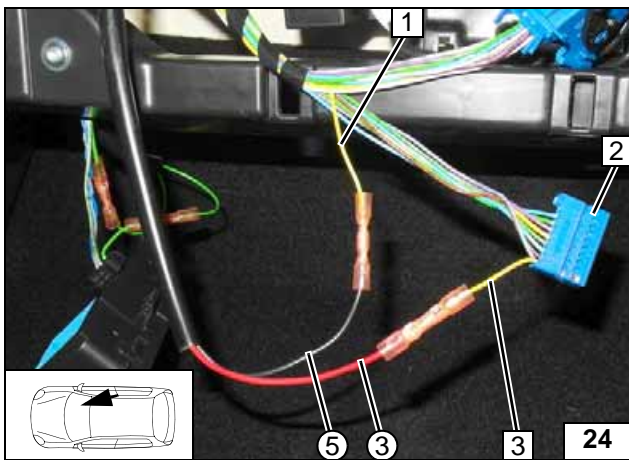

- 1 Yellow (ge) wire of fan controller connector, pin 1
- 2 Blue contact strip of connector 40V NR, pin 1-20
- 3 Yellow (ge) wire from blue contact strip of connector 40V NR, pin 20
- ③ Red (rt) wire of PWM-GW/IN
- ⑤ Black (sw) wire of PWM-GW/OUT

Connecting A/C control unit

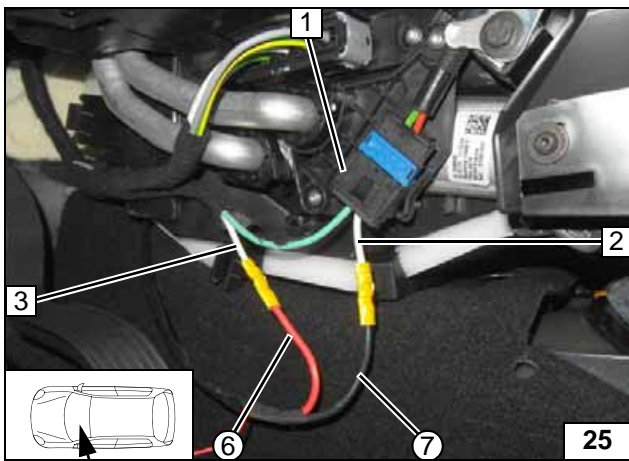

- 1 2-pin connector IC26
- 2 White (ws) wire of connector IC26, pin 3
- 3 White (ws) wire of fuse and relay carrier BFRM connector 54V NR, pin 53
- ⑥ Red (rt) wire from K1/87a, fan wiring harness
- ⑦ Black (sw) wire from K1/30, fan wiring harness

Connecting fan motor

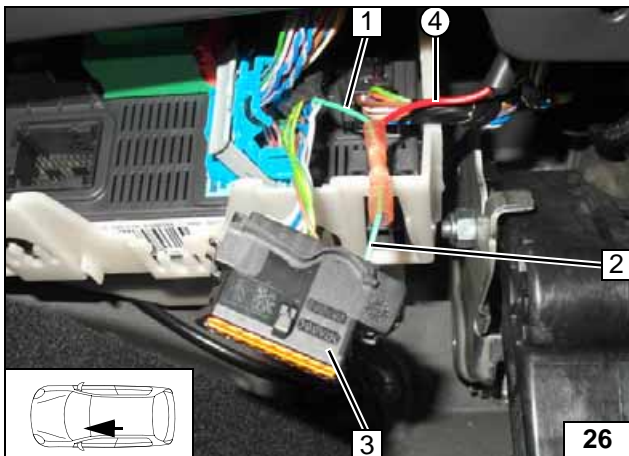

- 1 Green/white (gn/ws) wire of terminal 15
- 2 Green/white (gn/ws) wire of OBD socket outlet, pin 1
- 3 OBD socket outlet
- ④ Red (rt) wire from K2/86

Connecting terminal 15

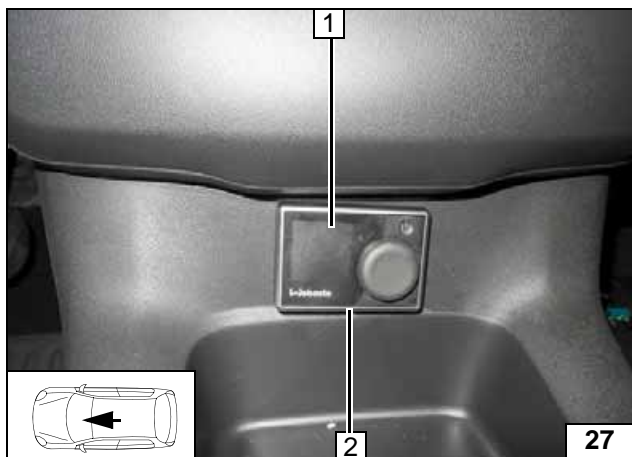

MultiControl CAR Option

- 1 MultiControl CAR
- 2 Hole for connection cable (hidden)



Installing
MultiControl
CAR

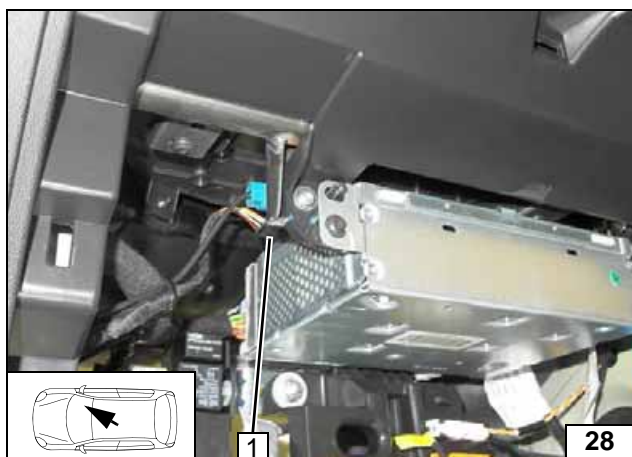

Remote Option (Telestart)

Attach receiver 1 (hidden), from above to radio / navigation system using double-sided adhesive tape!



Installing
receiver

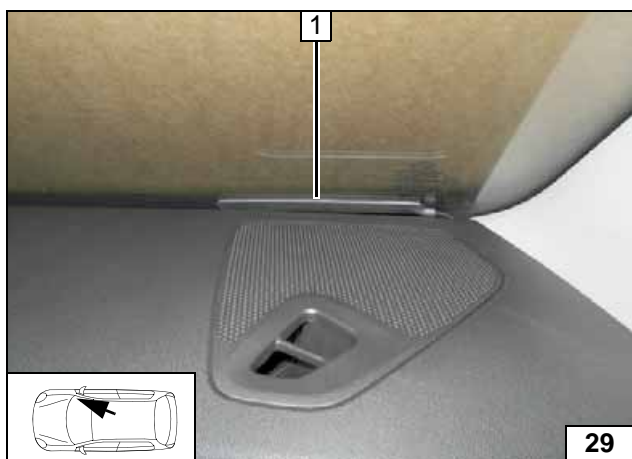

- 1 Antenna

Installing
antenna

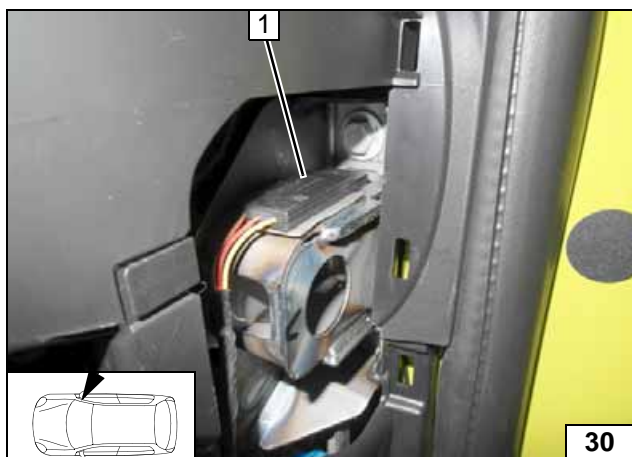

Temperature sensor T100 HTM

Fasten temperature sensor 1 with double-sided adhesive tape.



Installing
temperature
sensor

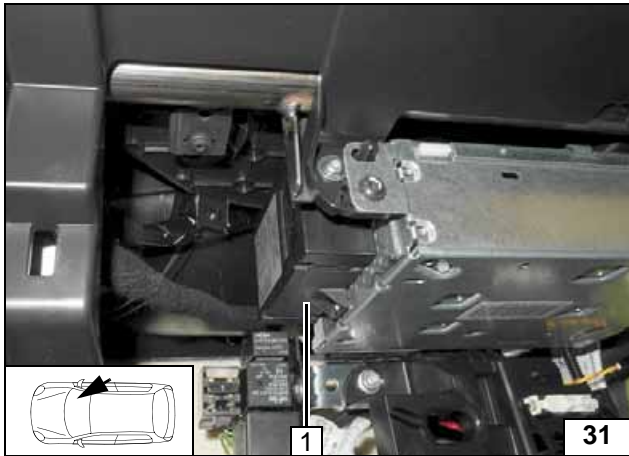

Thermo Call TC3 Option

Fasten receiver 1 with double-sided adhesive tape.



Installing receiver

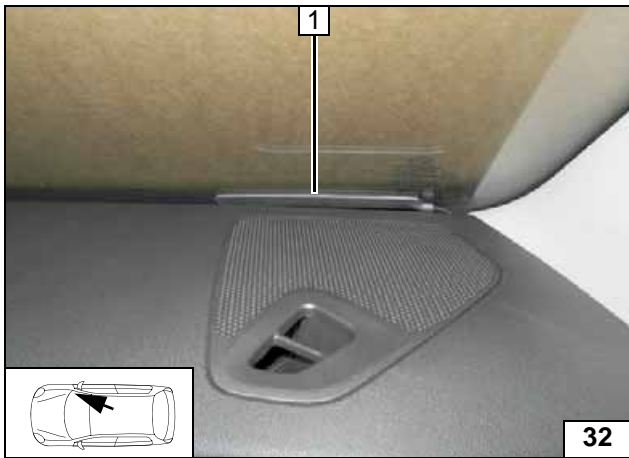

1 Antenna

Installing antenna

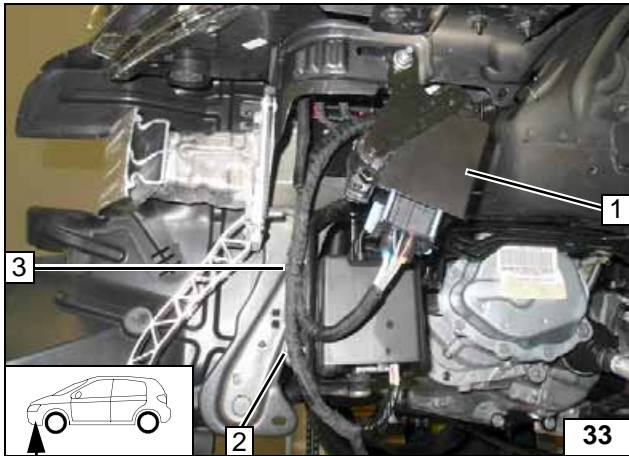
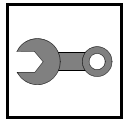

Preparing Installation Location



Remove control unit **1** with bracket, if present!

- 2** Remove original vehicle clip-type cable tie and discard
- 3** Remove original vehicle clip-type cable tie, will be reused

Removing control unit

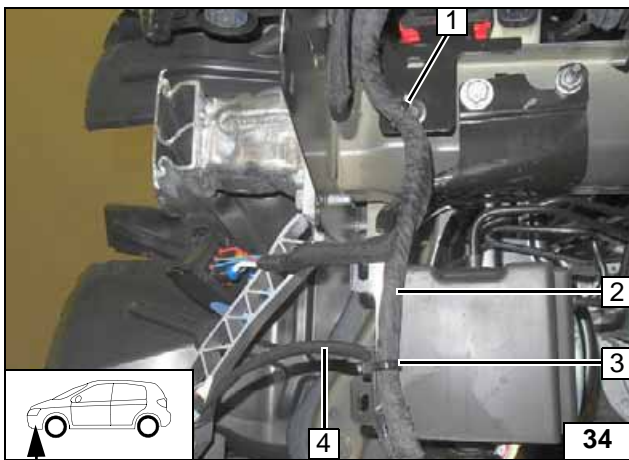

- 1** Install original vehicle clip-type cable tie, existing hole
- 2** Original vehicle wiring harness
- 3** Cable tie
- 4** Wiring harness of front fog light

Routing wiring harness

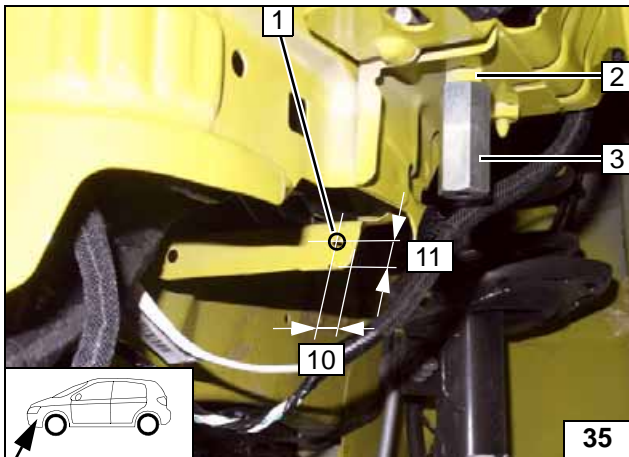

Remove original vehicle bolt at position **2** and discard.

- 1** 7 mm dia. hole
- 3** M6x20 bolt, spring lockwasher, large diameter washer, 40mm spacer nut

Installing spacer nut

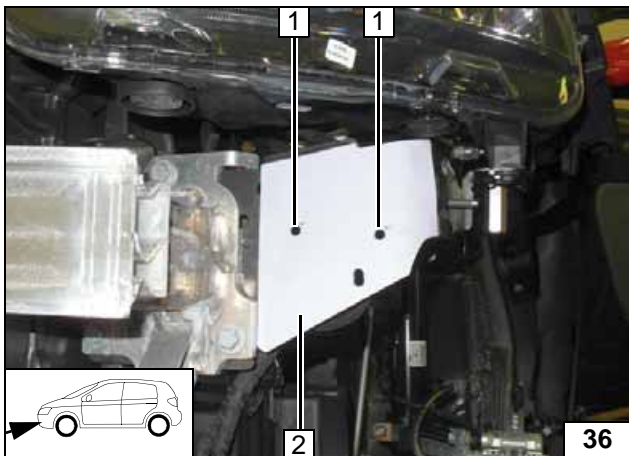

Cut out drilling template **2**, position and copy hole pattern!

- 1** 7mm dia. hole [2x]

Copying hole pattern

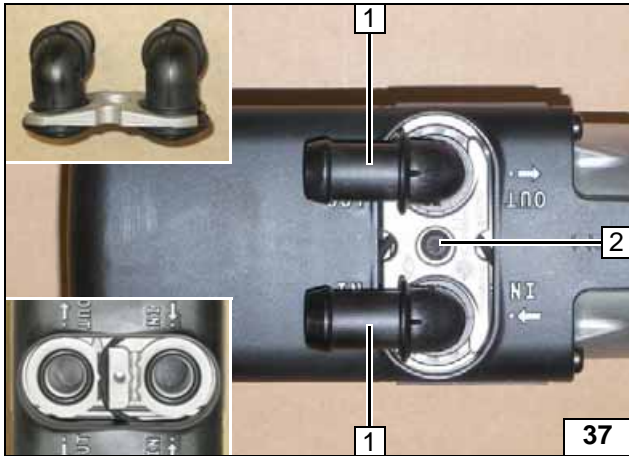
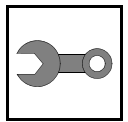

Preparing Heater

- 1 Water connection piece, sealing ring [2x each]
- 2 5x15 self-tapping bolt, retaining plate of water connection pieces



Mounting water connection piece

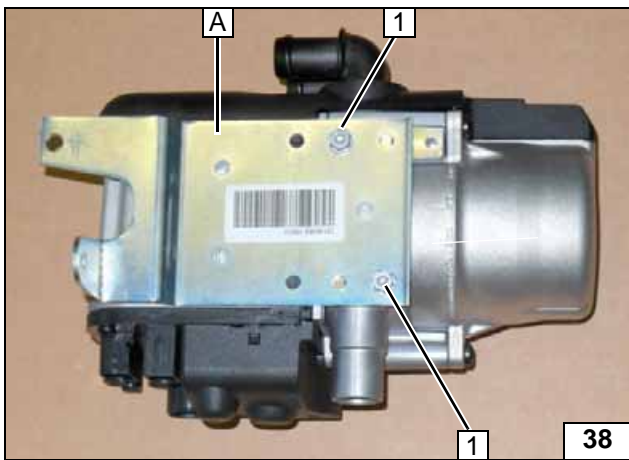

Prepare bracket **A** in accordance with the template!

- 1 5x13 self-tapping bolt [2x]



Installing bracket A

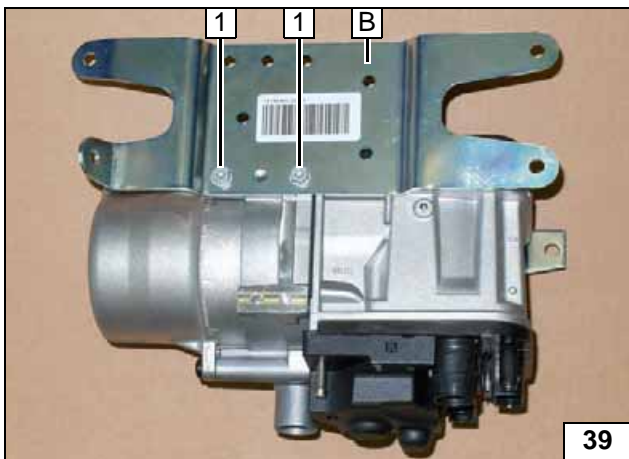

Prepare bracket **B** in accordance with the template!

- 1 5x13 self-tapping bolt [2x]



Installing bracket B

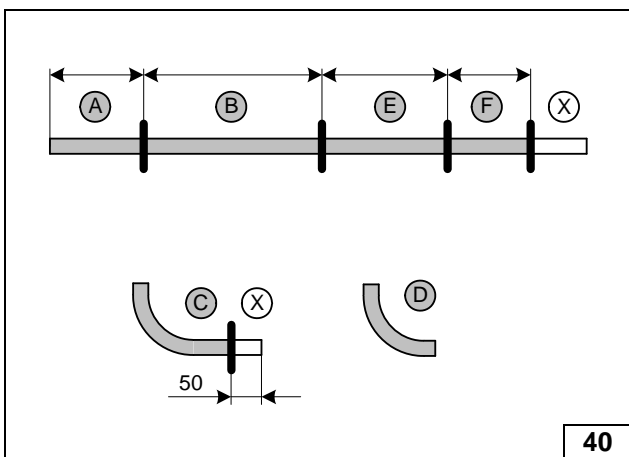

Discard section **X**.
 Hose **C** = 18mm dia., 90° moulded hose, shorten
 Hose **D** = 18mm dia., 90° moulded hose



Cutting hoses to length

	1.2 P 55 KW	1.2 P 81 KW	1.6 D all
A=	320	310	220
B=	510	510	520
E=	750	750	750
F=	260	290	210

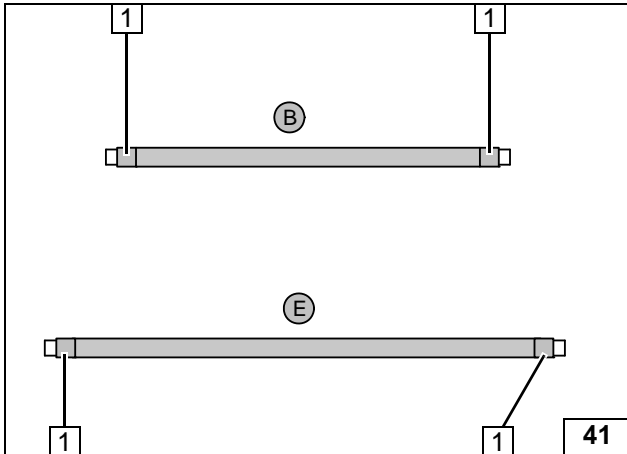

Slide on braided protection hoses and cut to length.



- 1 Cut heat shrink plastic tubing to size, 50mm long [4x]

Installing braided protection hoses

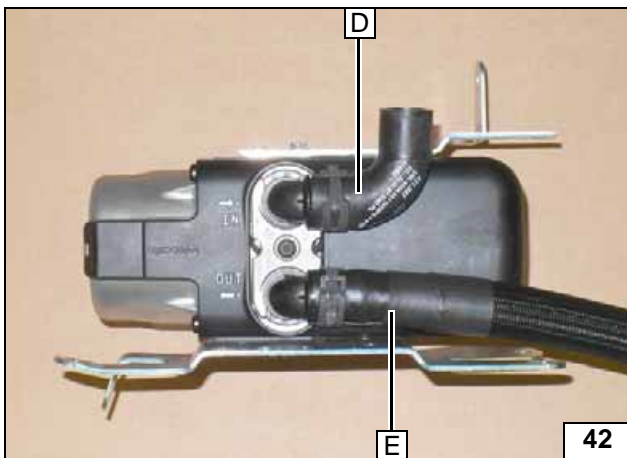

All spring clips = 25 mm dia.!

Premounting hoses

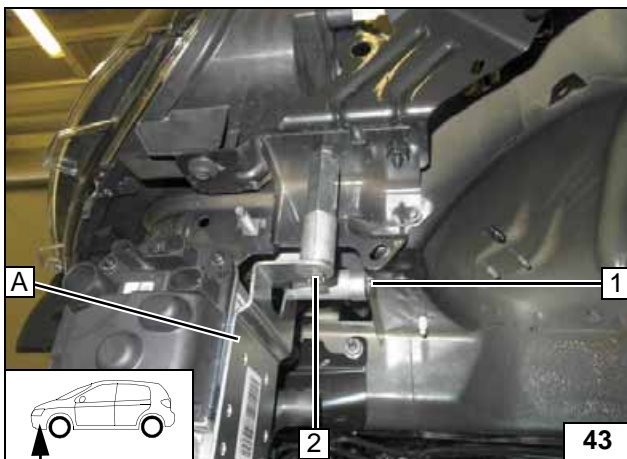

Installing Heater

- 1 M6x60 bolt, 40mm shim, 10mm shim, flanged nut on bracket A
- 2 M6x40 bolt, spring lockwasher, large diameter washer, 30mm shim on spacer nut

Mounting heater

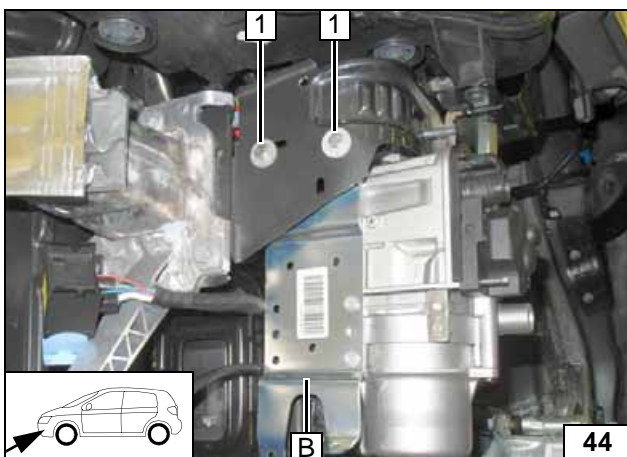

- 1 M6x25 bolt, large diameter washer, 10mm shim, flanged nut on bracket B [2x each]

Mounting heater

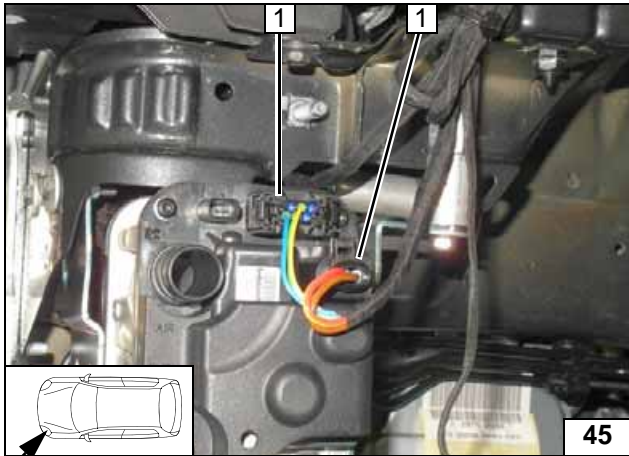
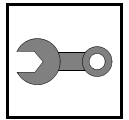

1 Heater wiring harness connector [2x]

Installing wiring harness of heater

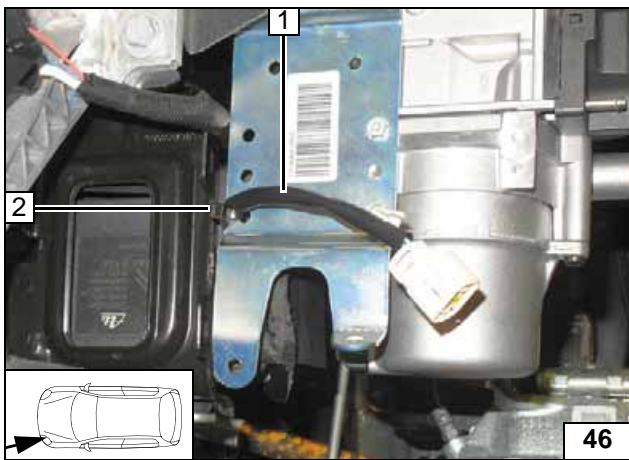

1 Wiring harness of front fog light
2 Cable tie

Attaching wiring harness

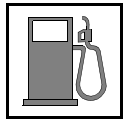

Fuel

CAUTION!

Open the vehicle's fuel tank cap, ventilate the tank and then re-close the tank lock.

Catch any fuel running off in an appropriate container.

Install fuel line and metering pump wiring harness so that they are protected against stone impact. Unless specified otherwise, always fasten using cable ties. Provide rub protection for fuel line and wiring harness in areas where there are sharp edges.

WARNING!

The fuel line and wiring harness are routed to the metering pump as shown in the wiring harness routing diagram.

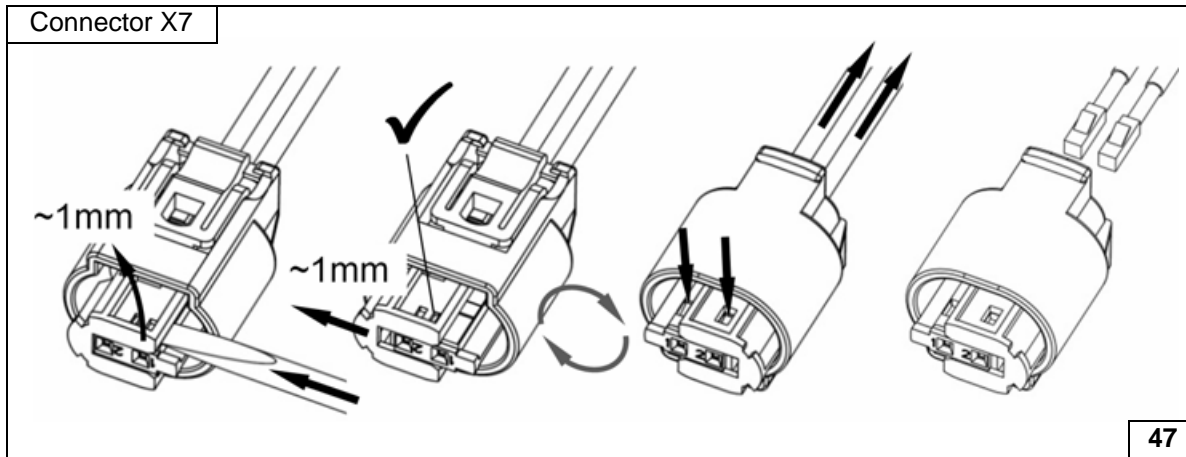

Dismantling metering pump connector

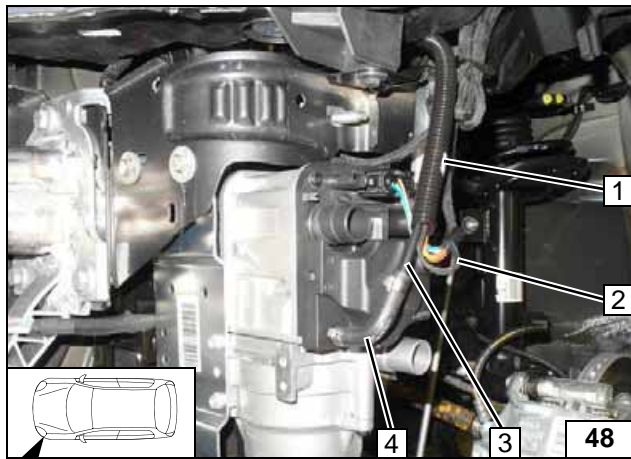

Pull fuel line 3 and wiring harness of metering pump 2 into 10mm dia. corrugated tube 1 and route in engine compartment.

4 90° moulded hose, 10mm dia. clamp [2x]



Connecting heater

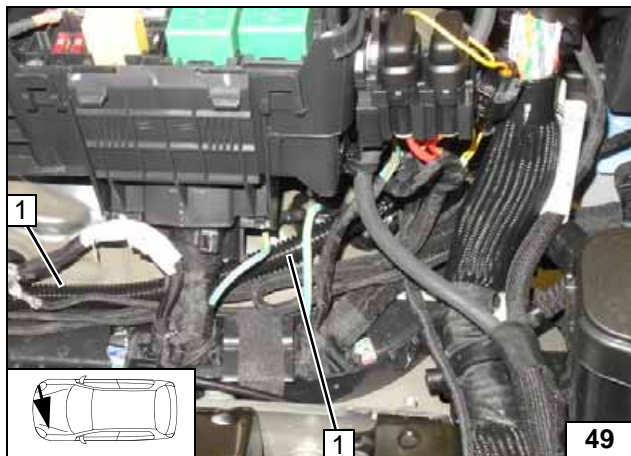

Route fuel line and wiring harness of metering pump into 10mm dia. corrugated tube 1 along original vehicle lines to the firewall!



Routing lines

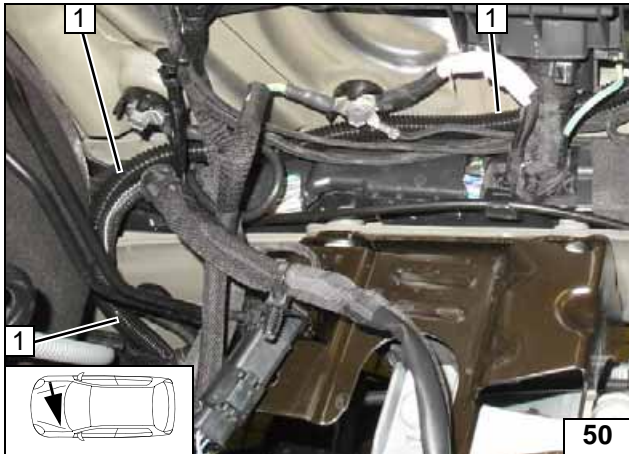
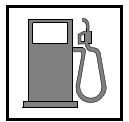

Route fuel line and wiring harness of metering pump into 10mm dia. corrugated tube **1** along original vehicle brake lines to the underbody.



Routing lines



Route fuel line and wiring harness of metering pump into 10mm dia. corrugated tube **1** on the underbody along original vehicle brake lines to the installation location of the metering pump!



Routing lines

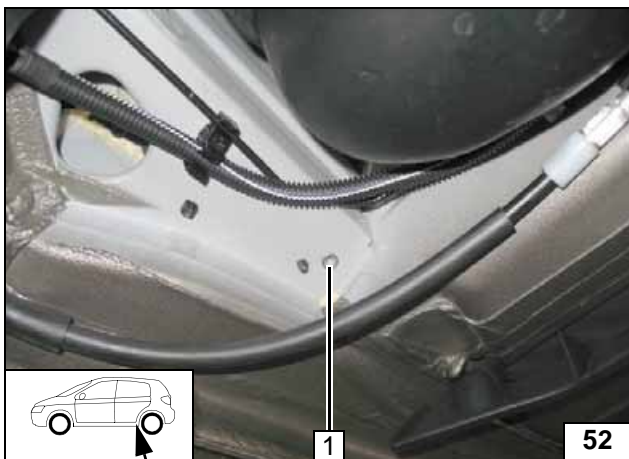

1 M6 rivet nut, existing hole

Installing rivet nut

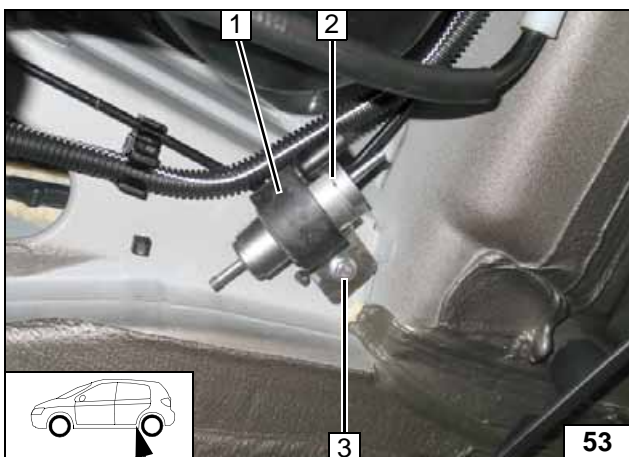

1 Mounting of metering pump
2 Metering pump
3 M6x25 bolt, support angle bracket on rivet nut



Installing metering pump

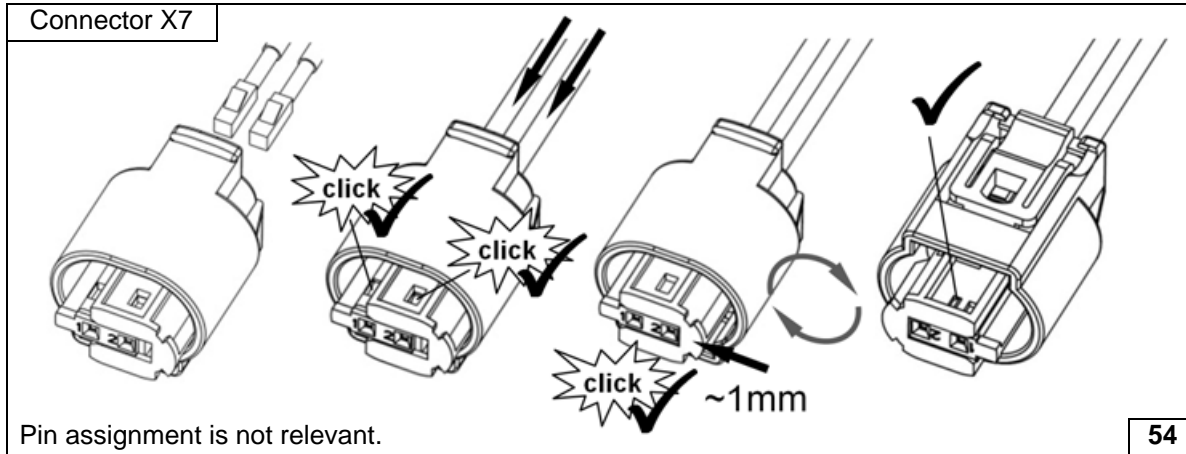
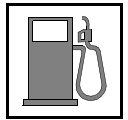

Completing metering pump connector

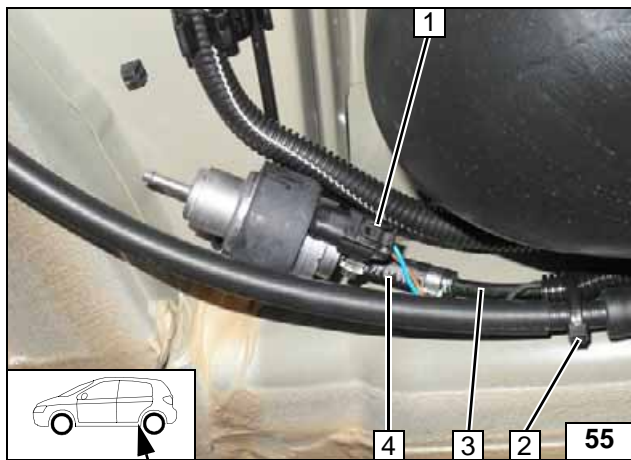

Check the position of the components; adjust if necessary. Check that they have freedom of movement.



- 1 Wiring harness of metering pump, connector X7 mounted
- 2 Cable tie
- 3 Fuel line of heater
- 4 Hose section, 10mm dia. clamp [2x]

Connecting metering pump

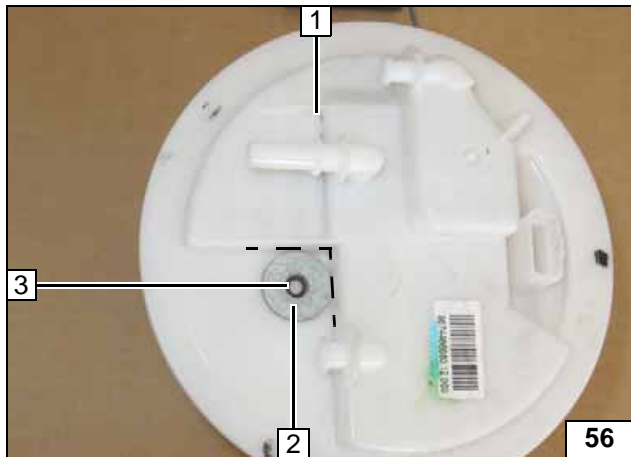

Petrol

The fuel-tank sending unit depends on the equipment.



Version A

Remove fuel-tank sending unit 1 in accordance with the manufacturer's instructions. Position large diameter washer with outer dia. $d_a = 21.6\text{mm}$ 2 against the ribs.

- 3 Copy hole pattern, 6mm dia. hole

Fuel extraction

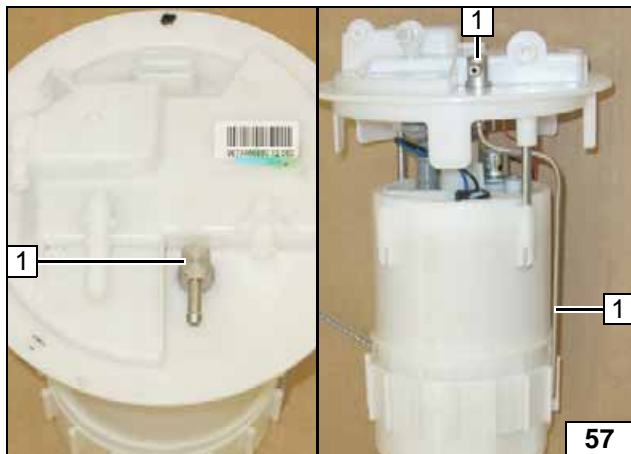

Bend fuel standpipe 1 according to template and cut to length.



Installing fuel standpipe

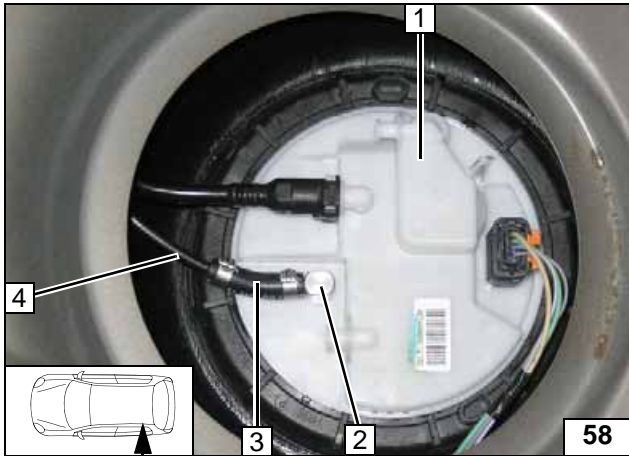
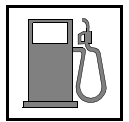

Install and complete fuel-tank sending unit 1 according to manufacturer's instructions.

- 2 Fuel standpipe
- 3 Hose section, 10mm dia. clamp [2x]
- 4 Fuel line



Connect-
ing fuel line

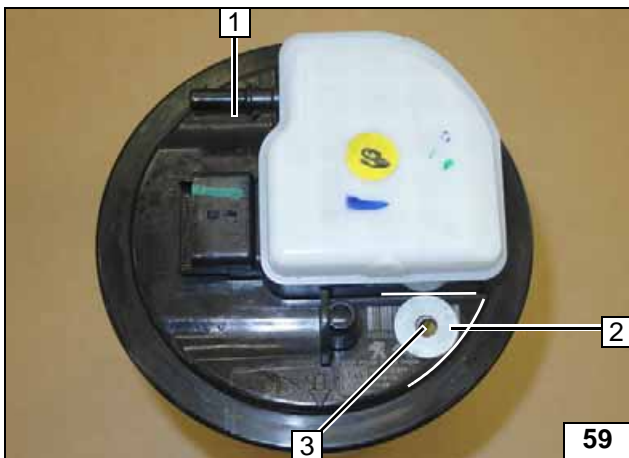

Version B

Remove fuel-tank sending unit 1 in accordance with the manufacturer's instructions. Position large diameter washer with outer dia. $d_a = 21.6\text{mm}$ 2 against the ribs.

- 3 Copy hole pattern, 6mm dia. hole



Fuel ex-
traction



Bend fuel standpipe 1 according to template and cut to length.



Installing
fuel stand-
pipe

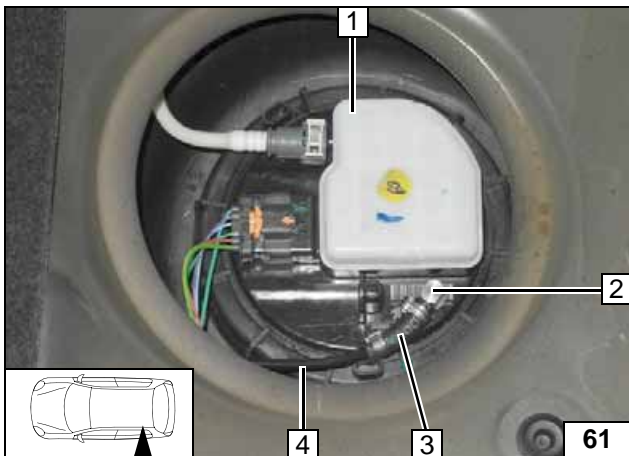

Install and complete fuel-tank sending unit 1 according to manufacturer's instructions.

- 2 Fuel standpipe
- 3 Hose section, 10mm dia. clamp [2x]
- 4 Fuel line



Connect-
ing fuel line

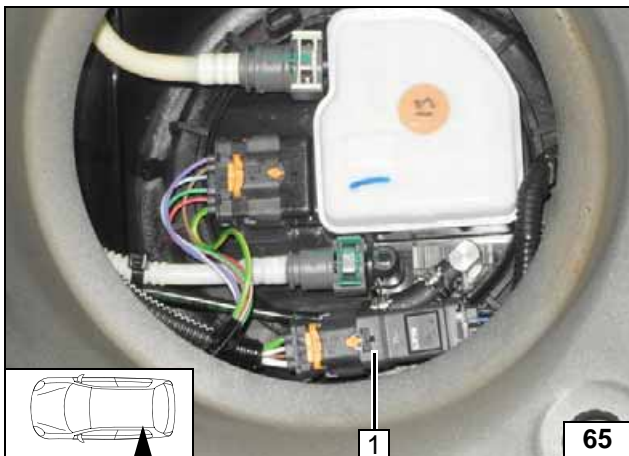
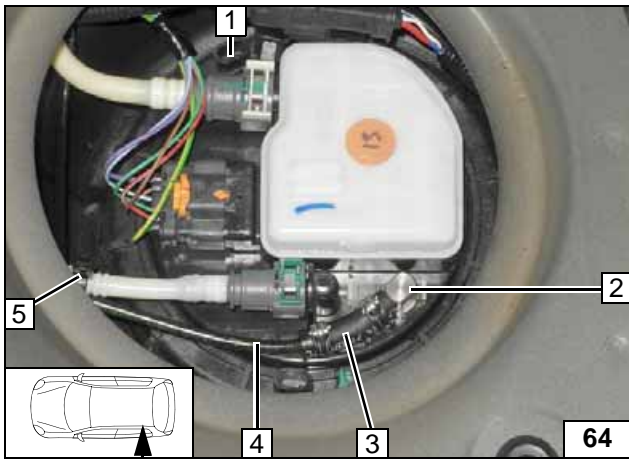
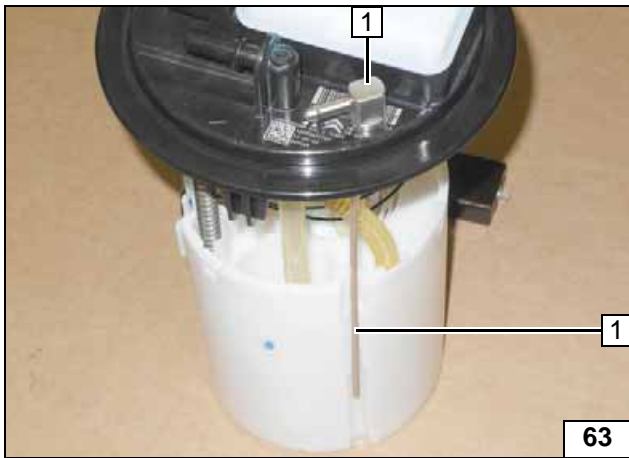
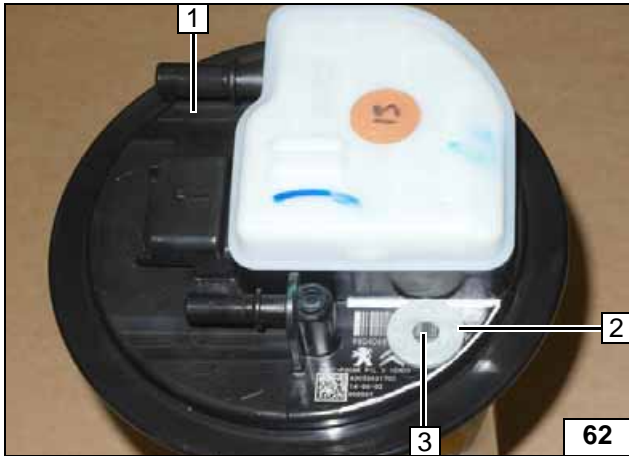
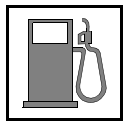

Diesel

The fuel-tank sending unit depends on the equipment.

Version A

Remove fuel-tank sending unit **1** in accordance with the manufacturer's instructions. Position large diameter washer with outer dia. $d_a = 21.6\text{mm}$ **2** against the ribs.

3 Copy hole pattern, 6mm dia. hole

Bend fuel standpipe **1** according to template and cut to length.

Install and complete fuel-tank sending unit **1** according to manufacturer's instructions.

- 2** Fuel standpipe
- 3** Hose section, 10mm dia. clamp [2x]
- 4** Fuel line
- 5** Cable tie

Align original vehicle wiring harness with connector **1** as shown!



Fuel extraction



Installing fuel standpipe



Connecting fuel line



Aligning wiring harness

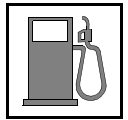

Fuel extraction



Installing fuel standpipe



Connecting fuel line



Connecting metering pump

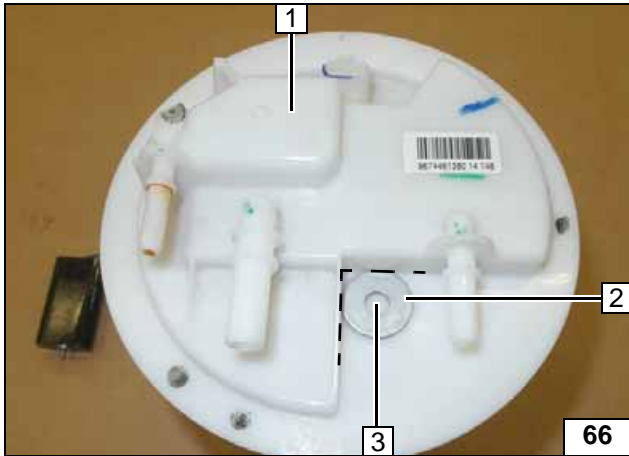

Version B

Remove fuel-tank sending unit **1** in accordance with the manufacturer's instructions. Position large diameter washer with outer dia. $d_a = 21.6$ **2** against the ribs.

3 Copy hole pattern, 6mm dia. hole



Bend fuel standpipe **1** according to template and cut to length.

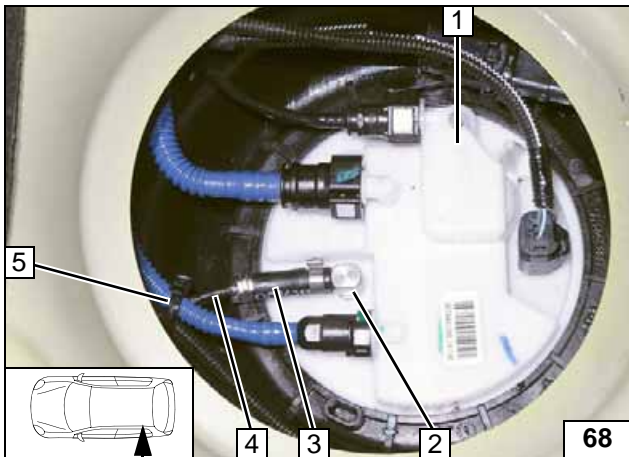

Install and complete fuel-tank sending unit **1** according to manufacturer's instructions.

- 2** Fuel standpipe
- 3** Hose section, 10mm dia. clamp [2x]
- 4** Fuel line
- 5** Cable tie

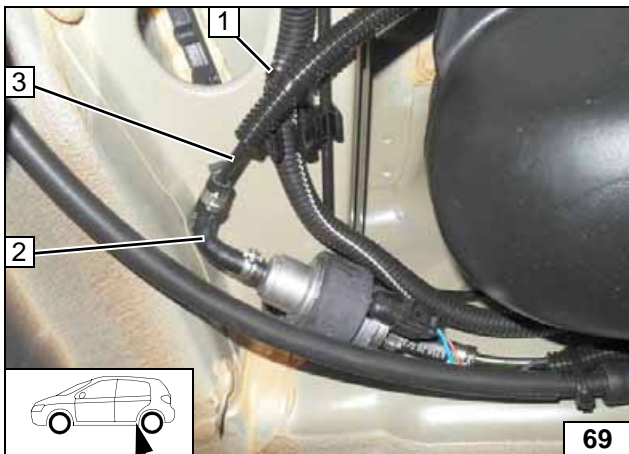

All vehicles

Slide 10mm dia. corrugated tube onto fuel line of fuel standpipe **3**. Ensure sufficient distance from neighbouring components, adjust if necessary.

- 1** Cable tie
- 2** 90° moulded hose, 10mm dia. clamp [2x]





Coolant Circuit

WARNING!

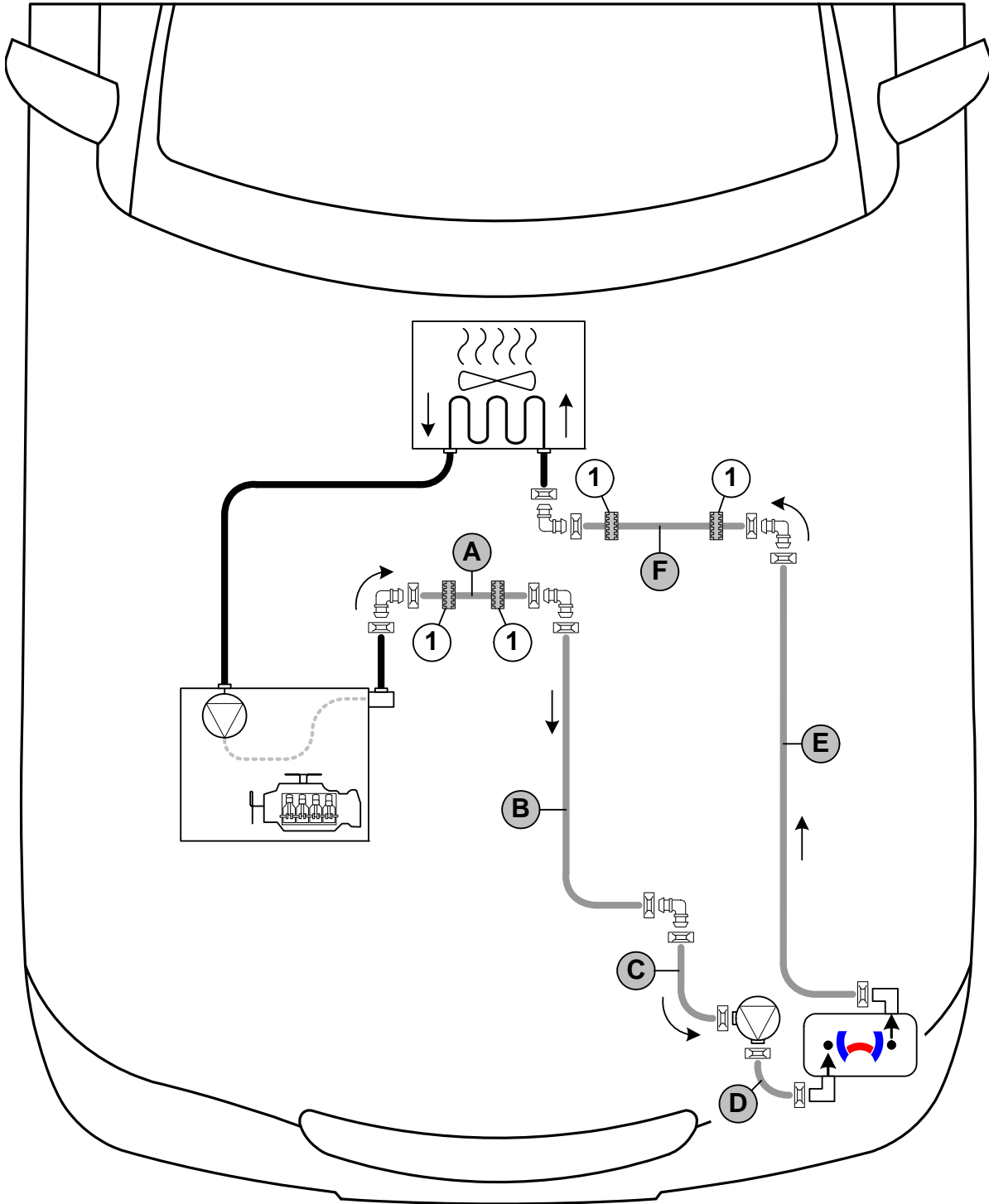
Any coolant running off should be collected in an appropriate container. Route hoses so that they are kink-free. Unless specified otherwise, always fasten using cable ties. Position clamps so that other hoses cannot be damaged. The heater must be filled with coolant when installing the hoses. The connection should be modelled on an "inline" circuit and based on the following diagram:



Hose routing diagram

All spring clips  = 25 mm dia.
 1 = Black (sw) rubber isolator .
 All connecting pipes  = 18x18mm dia.



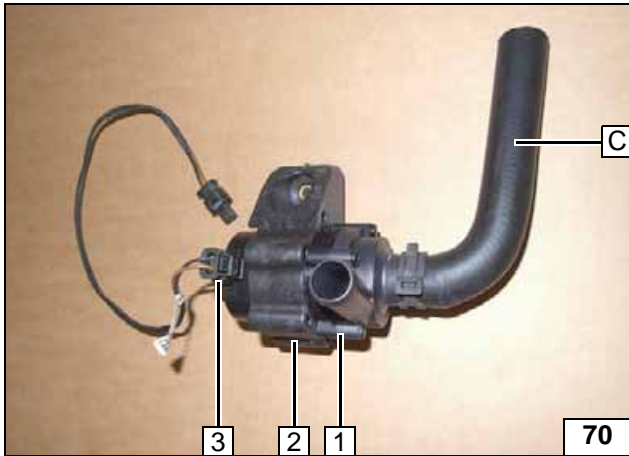

All vehicles

- 1 Circulating pump
- 2 Circulating pump mounting
- 3 Connector of circulating pump wiring harness

Preparing circulating pump

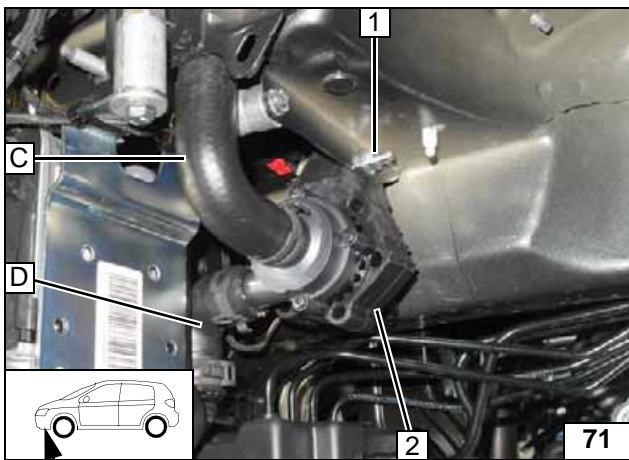

- 1 M6x25 bolt, flanged nut in existing hole
- 2 Circulating pump mounting

Installation / connection of circulating pump

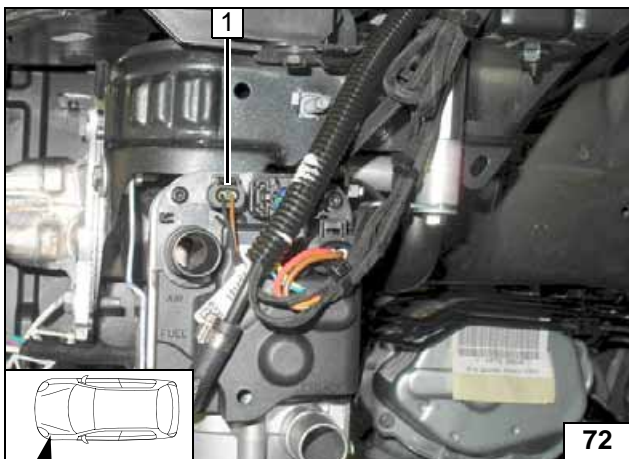

- 1 Connector of circulating pump wiring harness

Installing wiring harness of circulating pump

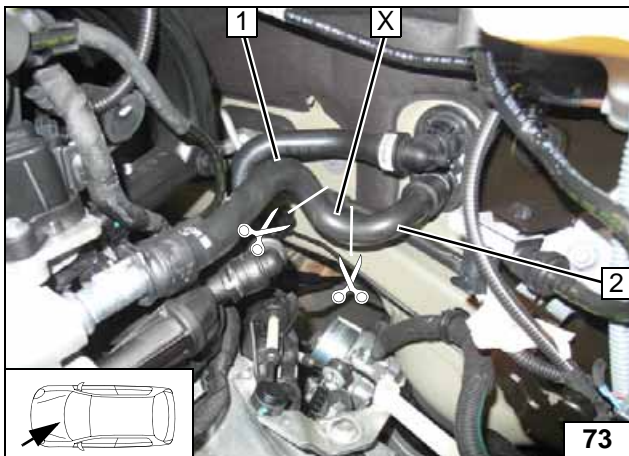

1.2l Petrol, 55KW

Cut hose on engine outlet / heat exchanger inlet at the marking.
Discard section X (90° elbow)!

- 1 Hose section of engine outlet
- 2 Hose section of heat exchanger inlet

Cutting point

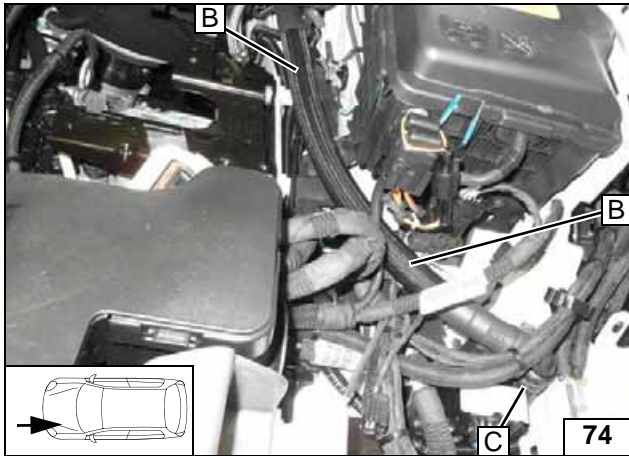

Routing in engine compartment

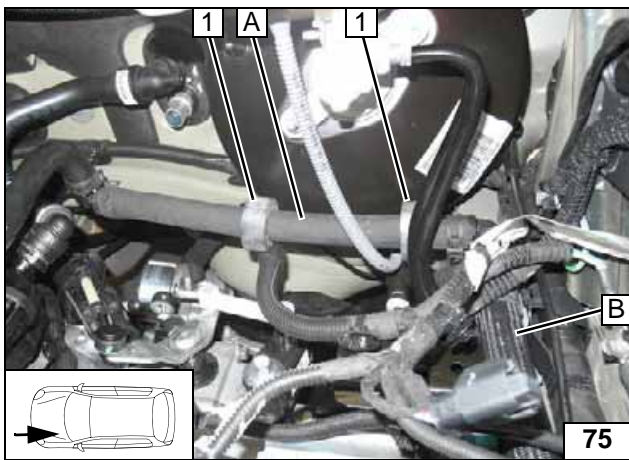

Slide on black (sw) rubber isolator 1 [2x], align with original vehicle wiring harness and brake lines!



Routing in engine compartment

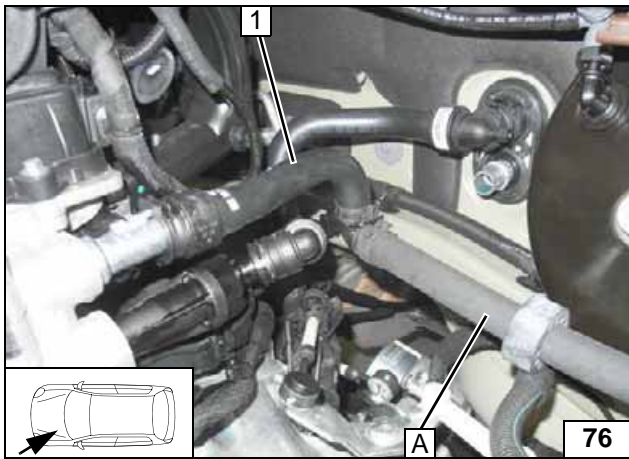

1 Hose section of engine outlet

Connecting engine outlet



Routing in engine compartment

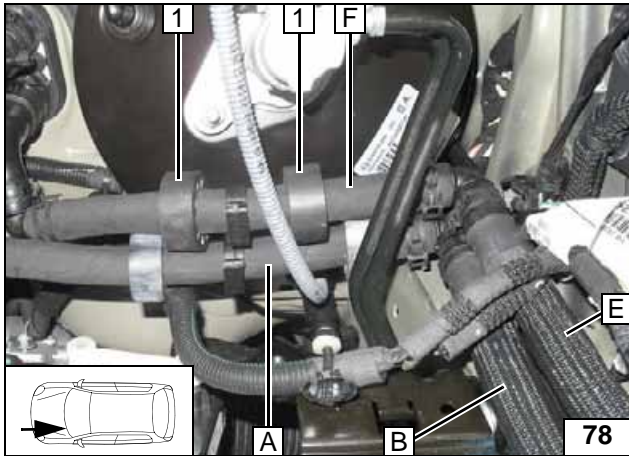

Align black (sw) rubber isolator 1 [2x] with brake booster!



Routing in engine compartment

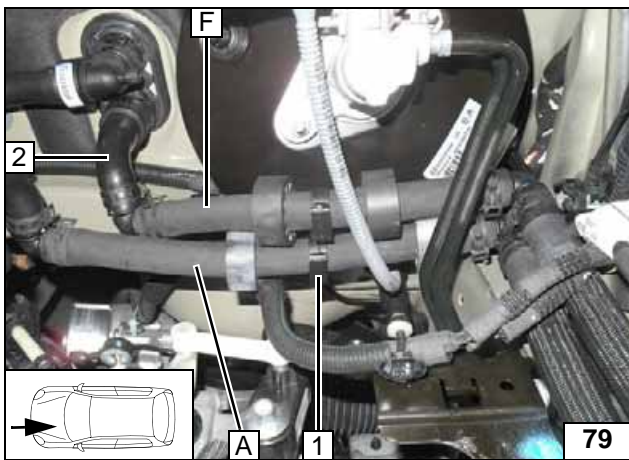

Align hoses. Ensure sufficient distance from neighbouring components, adjust if necessary.



- 1 Install lockable hose bracket
- 2 Hose section of heat exchanger inlet

Connecting heat exchanger inlet

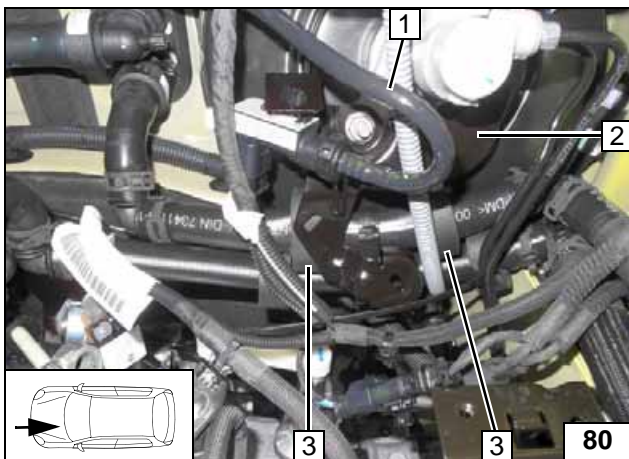

Install original vehicle bracket 2 (if present) on brake booster. Install original vehicle vacuum line 1. Align black (sw) rubber isolator 3 [2x] with bracket!



Installing bracket

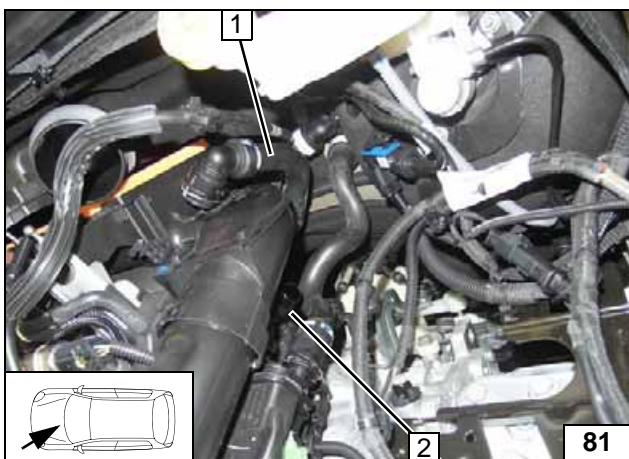

1.2l Petrol, 81KW

To simplify the installation, remove hose of engine inlet / heat exchanger outlet 1 from engine inlet connection piece 2.



Cutting point/ coolant connection

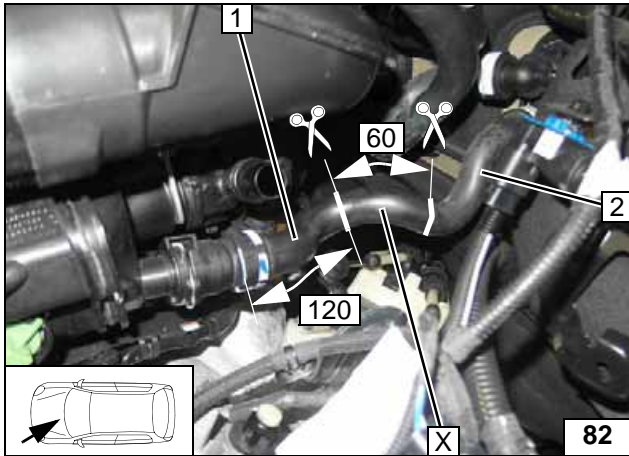

Cut hose on engine outlet / heat exchanger inlet at the marking.
Discard section X (90° elbow)!

- 1 Hose section of engine outlet
- 2 Hose section of heat exchanger inlet



Cutting point

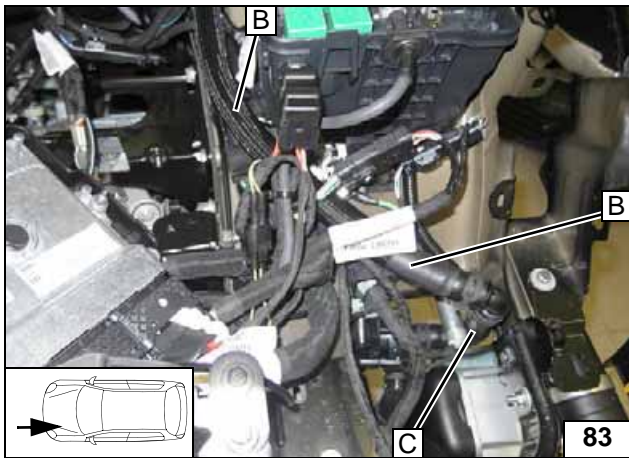

Routing in engine compartment

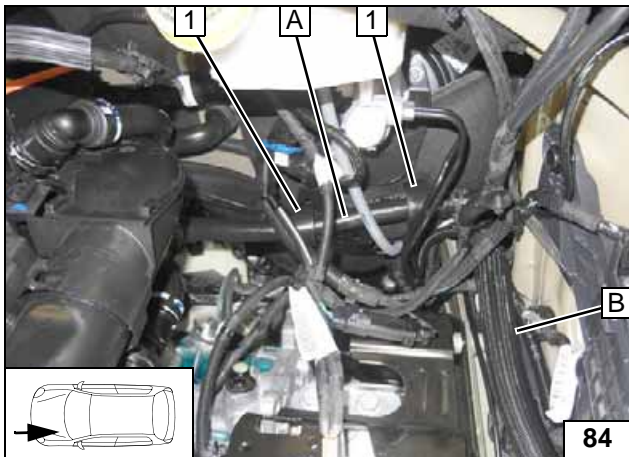

Slide on black (sw) rubber isolator 1 [2x], align with original vehicle wiring harness and brake lines!



Routing in engine compartment

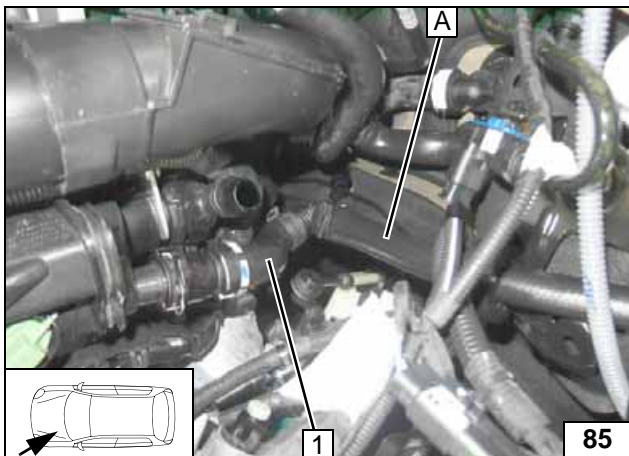

- 1 Hose section of engine outlet

Connecting engine outlet

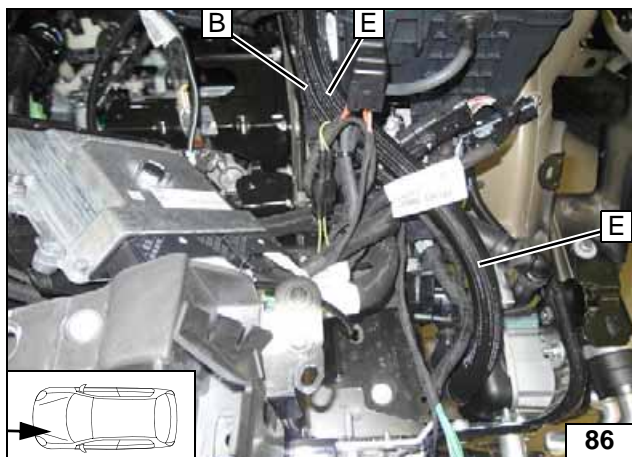

Routing in engine compartment

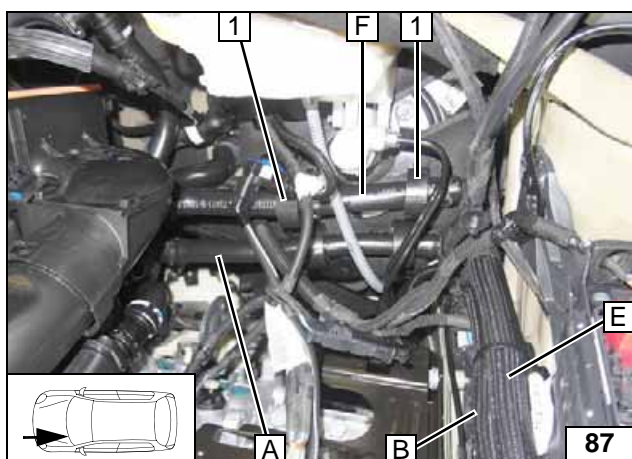

Align black (sw) rubber isolator 1 [2x] with brake booster!



Routing in engine compartment

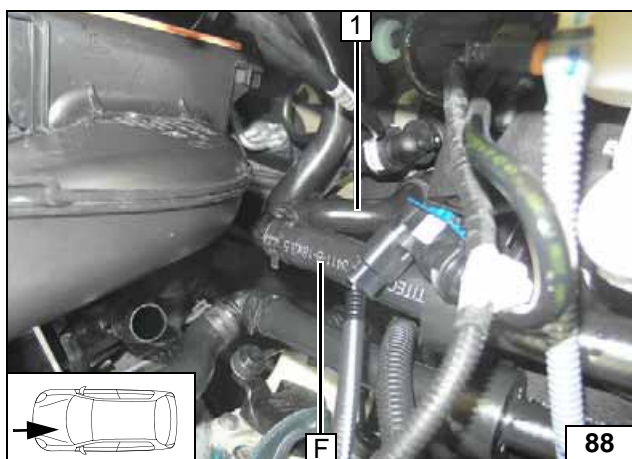

1 Hose section of heat exchanger inlet

Connecting heat exchanger inlet

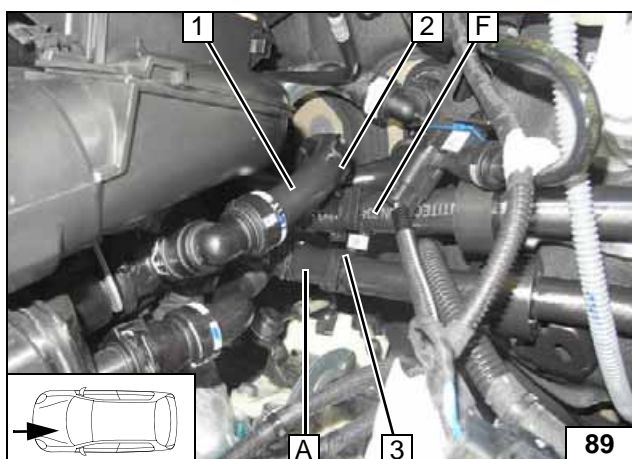

Align hoses. Ensure sufficient distance from neighbouring components, adjust if necessary.



Installing hose bracket

- 1 Hose of heat exchanger outlet / engine inlet installed
- 2 25x25 rotatable hose bracket between hose 1 and hose F
- 3 25x25 lockable hose bracket between hose A and hose F



Diesel

Remove hose 1 from engine outlet/heat exchanger inlet.



Cutting point

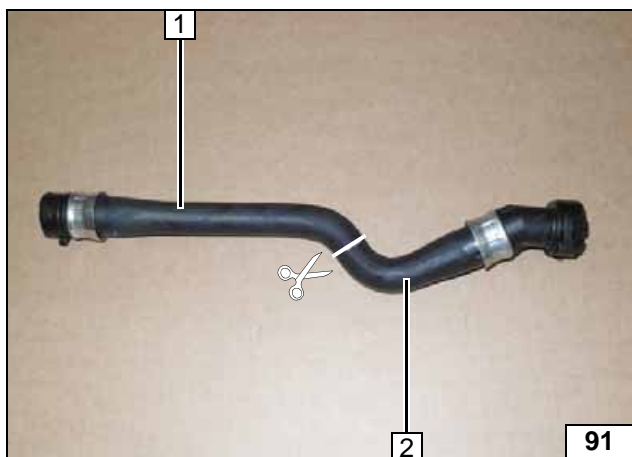

Cut off hose on engine outlet/heat exchanger inlet at marking.

- 1 Hose section of engine outlet
- 2 Hose section of heat exchanger inlet



Cutting point

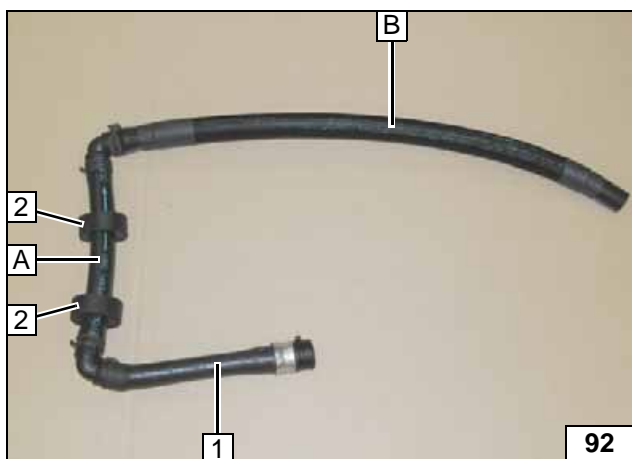

Slide on black (sw) rubber isolator 2 [2x] as shown!

- 1 Hose section of engine outlet



Preparing hose of engine outlet

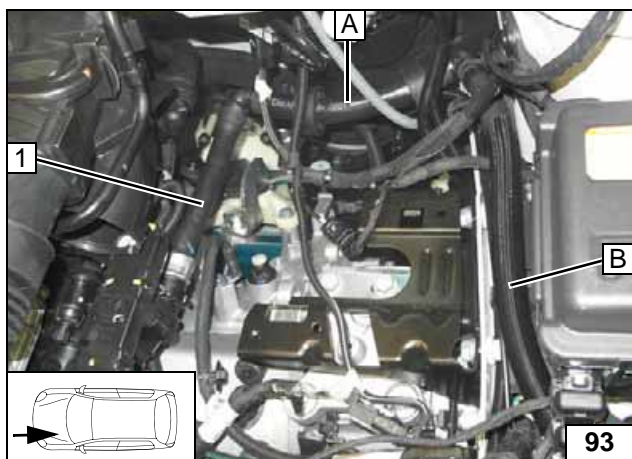

- 1 Hose section of engine outlet

Connecting engine outlet

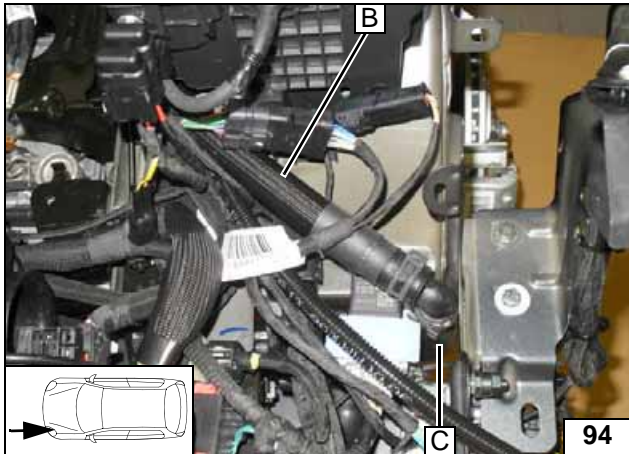

Routing in engine compartment

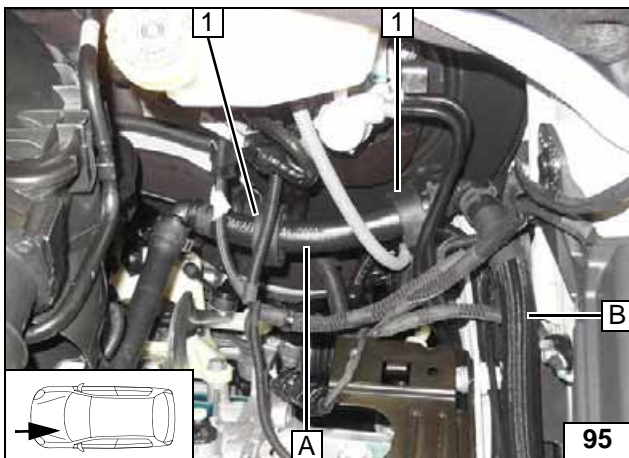

Slide on black (sw) rubber isolator 1 [2x], align with brake booster, original vehicle wiring harness and brake lines!



Aligning rubber isolator

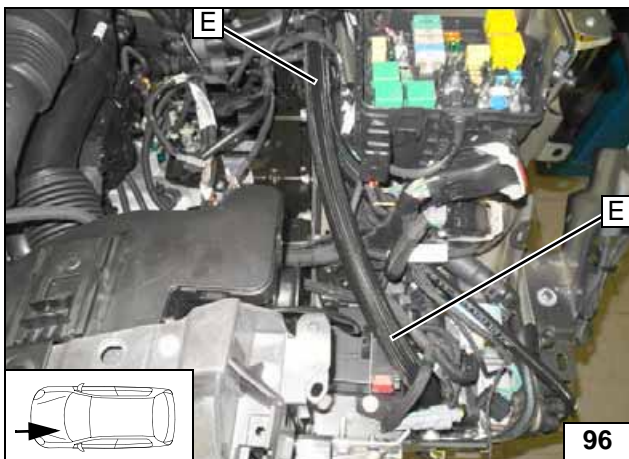

Routing hose E

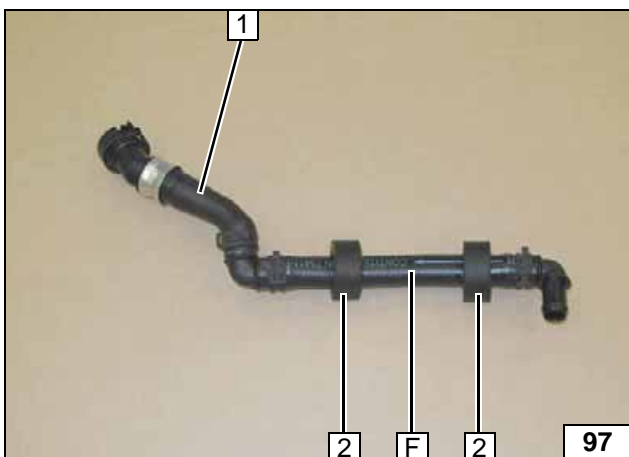

Slide on black (sw) rubber isolator 2 [2x] as shown!



1 Hose section of heat exchanger inlet

Preparing hose of heat exchanger inlet

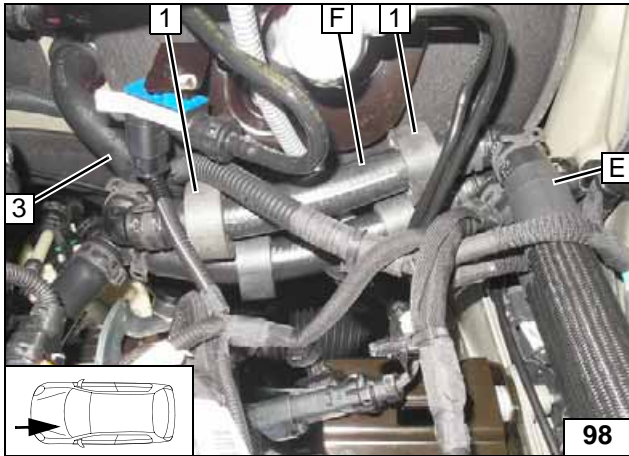

Slide on black (sw) rubber isolator 1 [2x], align with brake booster, original vehicle wiring harness and brake lines!

3 Hose section of heat exchanger inlet

**Connect-
ing heat ex-
changer
inlet**

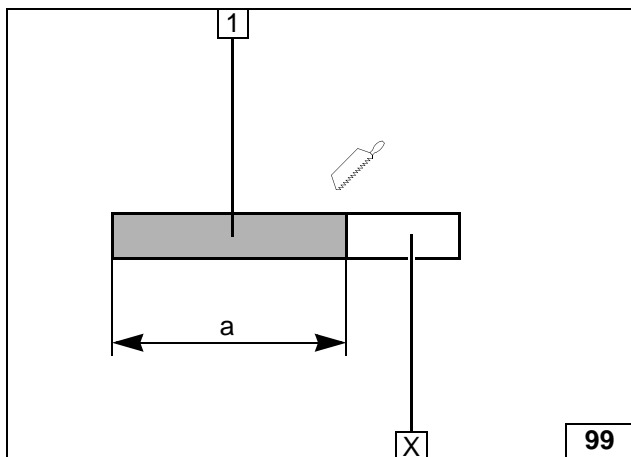
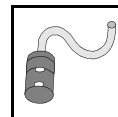

Combustion Air

Discard section X.

- 1 Combustion air pipe
a = 300



Cutting combustion air pipe to length

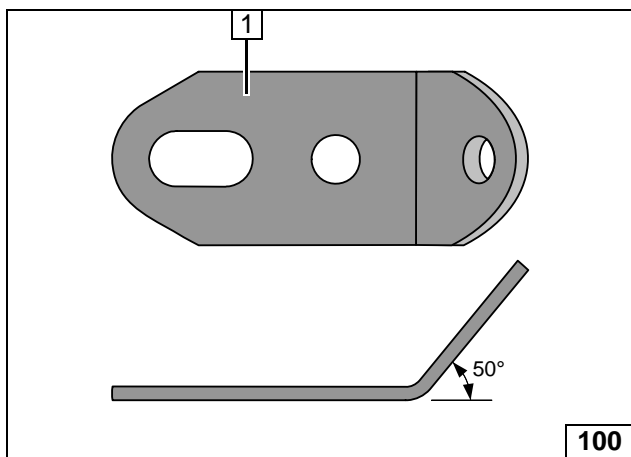

- 1 Angle bracket

Preparing angle bracket

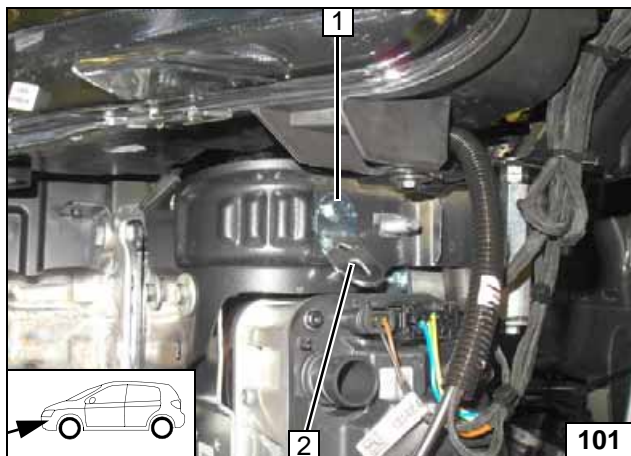

- 1 M6x20 bolt, flanged nut in existing hole
- 2 Angle bracket

Installing angle bracket

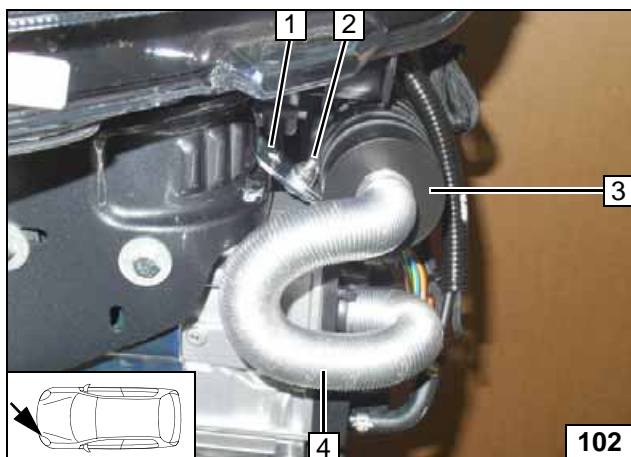

- 1 Angle bracket
- 2 M5x16 bolt, washer, 51mm dia. p-clamp, flanged nut
- 3 Silencer
- 4 Combustion air pipe



Mounting silencer / combustion air pipe

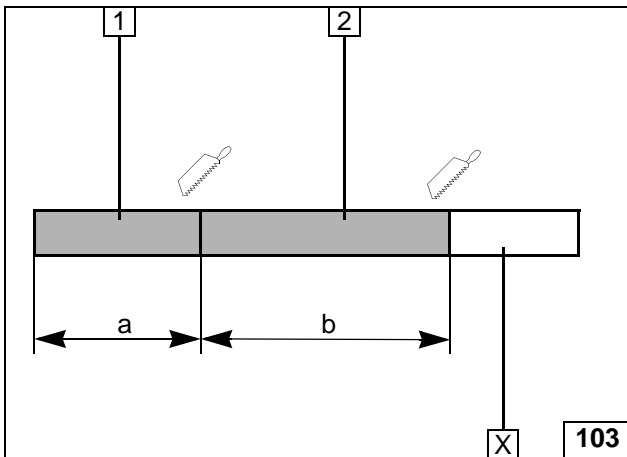
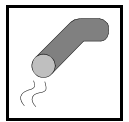

Exhaust Gas

Discard section X.

- 1 Exhaust pipe
a = 260
- 2 Exhaust end section
b = 340



Preparing exhaust pipe

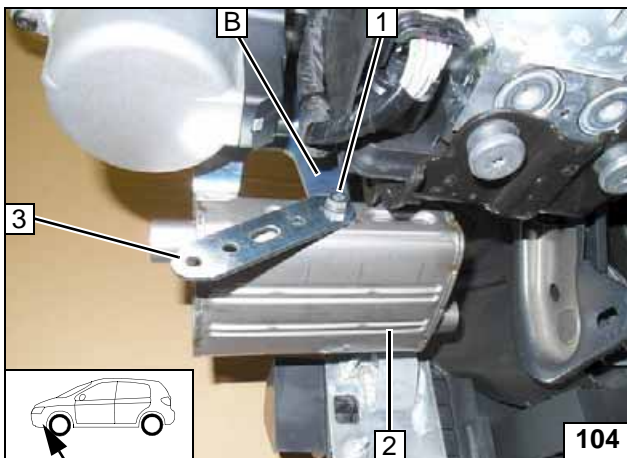

- B Bracket
- 1 M6x16 bolt, spring lockwasher
- 2 Silencer
- 3 Perforated bracket

Installing silencer

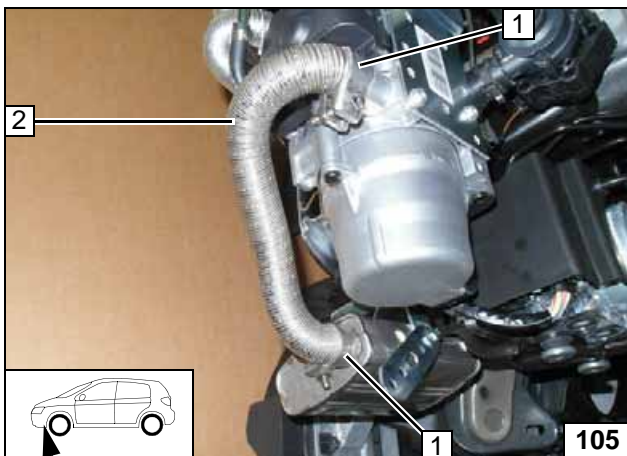

- 1 Hose clamp [2x]
- 2 Exhaust pipe



Installing exhaust pipe

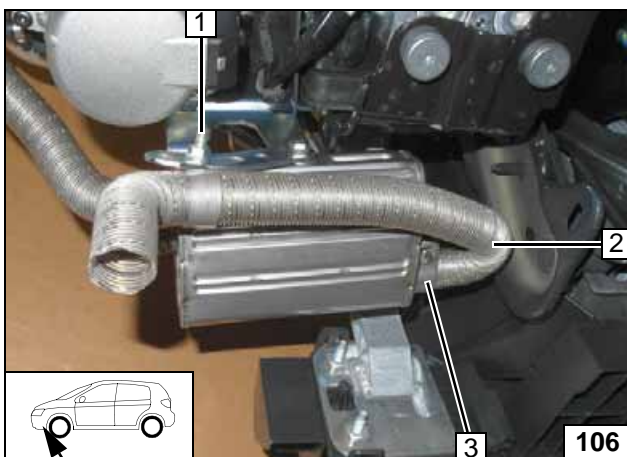

Check the position of the components; adjust if necessary. Check that they have freedom of movement.

- 1 M6x20 bolt, p-clamp, flanged nut
- 2 Exhaust end section
- 3 Hose clamp



Installing exhaust end section

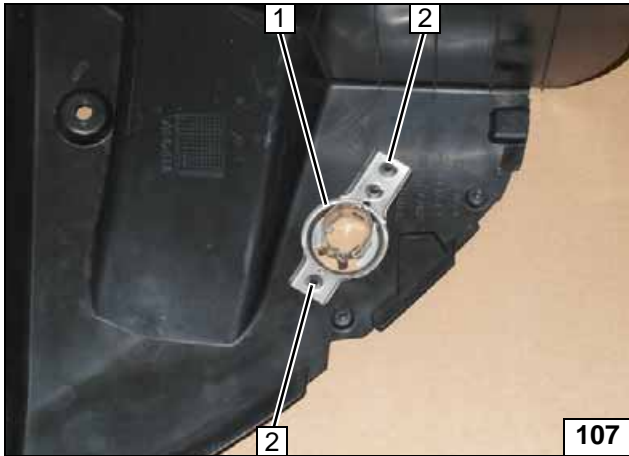
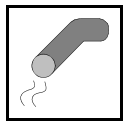

Align exhaust end fastener **1** in the existing hole of the wheel well trim as per work step 3 of the installation instructions and copy hole pattern **2** [2x]!



Copying hole pattern

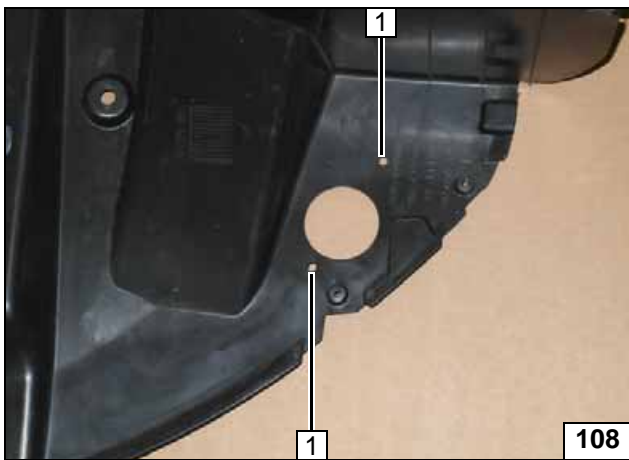

Hole **1** [2x] as per work step 4 of the installation instructions.



Holes in wheel well trim

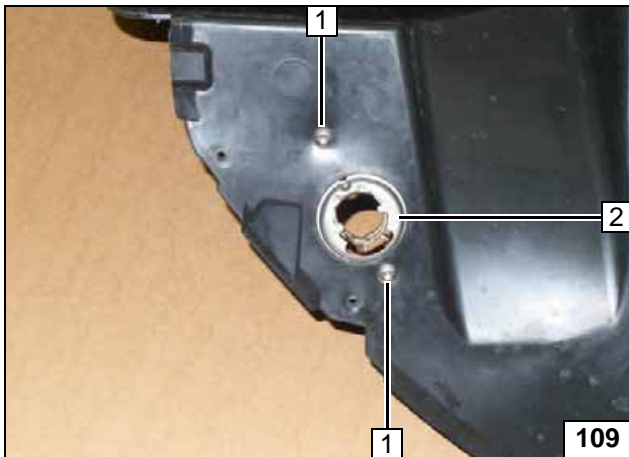

- 1** Self-tapping screw 5x13 [2x] according to work step 5 of the installation instructions
- 2** Exhaust end fastener



Installing exhaust end fastener

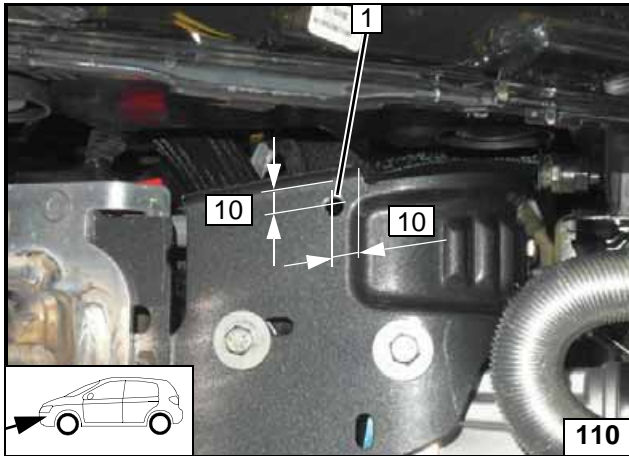
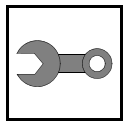

Final Work

Hole, only if the control unit is present (see following image). When drilling, watch components located behind!

- 1 7 mm dia. hole



Hole for control unit

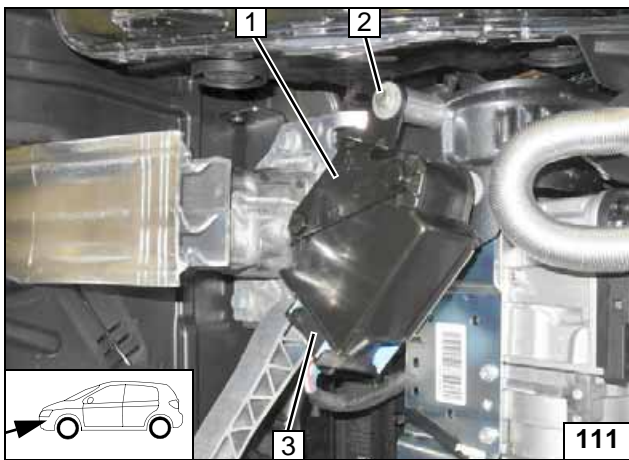

- 1 Control unit with bracket, if present
- 2 M6x50 bolt, large diameter washer, 40mm shim, flanged nut
- 3 Connector mounted

Installing control unit

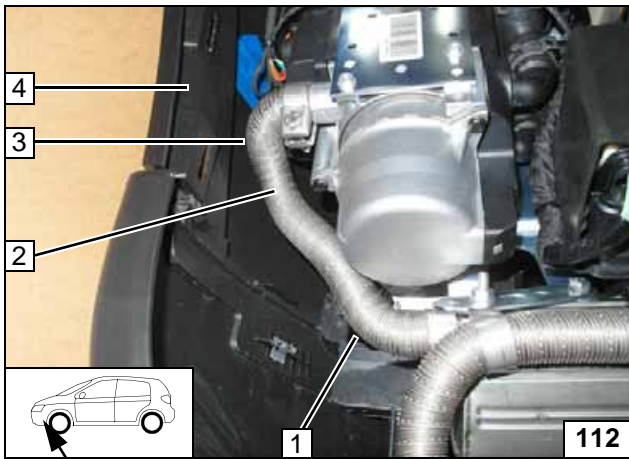

Install bumper 4. Ensure sufficient distance (at least 20mm) between exhaust pipe 2 and bumper in position 3 as well as front fog light in position 1, correct if necessary!



Aligning exhaust pipe

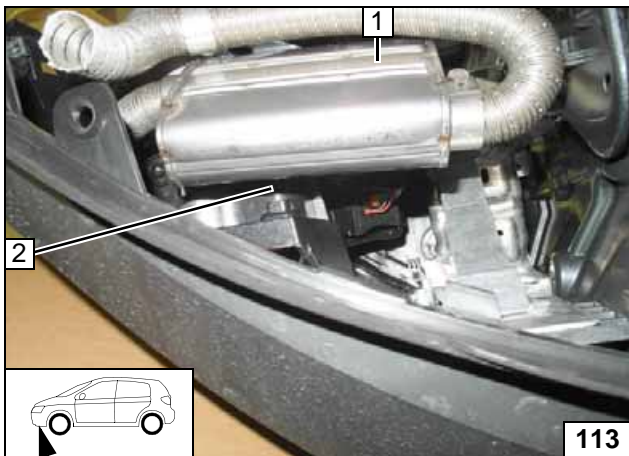

Ensure sufficient distance (at least 20mm) between exhaust silencer 1 and bracket of front fog light in position 2, correct if necessary!



Aligning exhaust silencer

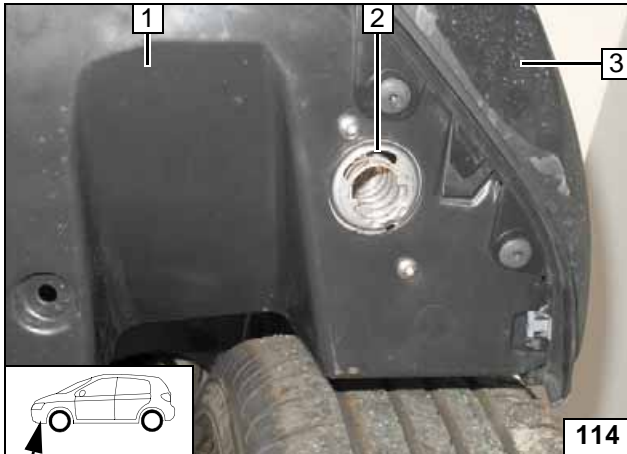
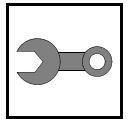

Install bumper **3** and wheel well trim **1**.
Mount exhaust end section **2** according to
work step 6 - 8 of the installation instructions.



Installing exhaust end section

WARNING!

Reassemble the components in reverse order. Check all hoses, clamps and all electrical connections for firm seating. Insulate and tie back all loose lines.

Only use manufacturer-approved coolant. Spray the heater components with anti-corrosion wax (Tectyl 100K, Order No. 111329).

Use two retaining clamps for the installation of the rear bench seat (Citroen Order No. 1609267180)!



- **Connect the battery.**
- **Fill and bleed the coolant circuit according to the vehicle manufacturer's specifications.**
- **Program MultiControl CAR, teach Telestart transmitter**
- **To avoid incorrect entries in the engine control unit in case of engine version 1.2 petrol, 81KW, the BSI must be encoded for "external pre-air conditioning" under the menu item "Presence and type of pre-air conditioning" (subsequent alteration).**
- **Make settings on A/C control panel according to the "Operating Instructions for End Customer".**
- **Place the "Switch off parking heater before refuelling" caution label near the filler neck**
- **See installation instructions for initial start-up and function check**

Webasto Thermo & Comfort SE
Postfach 1410
82199 Gilching
Germany
Internet: www.webasto.com
Technical Extranet:
<http://dealers.webasto.com>

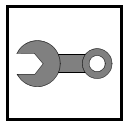

Drilling Template

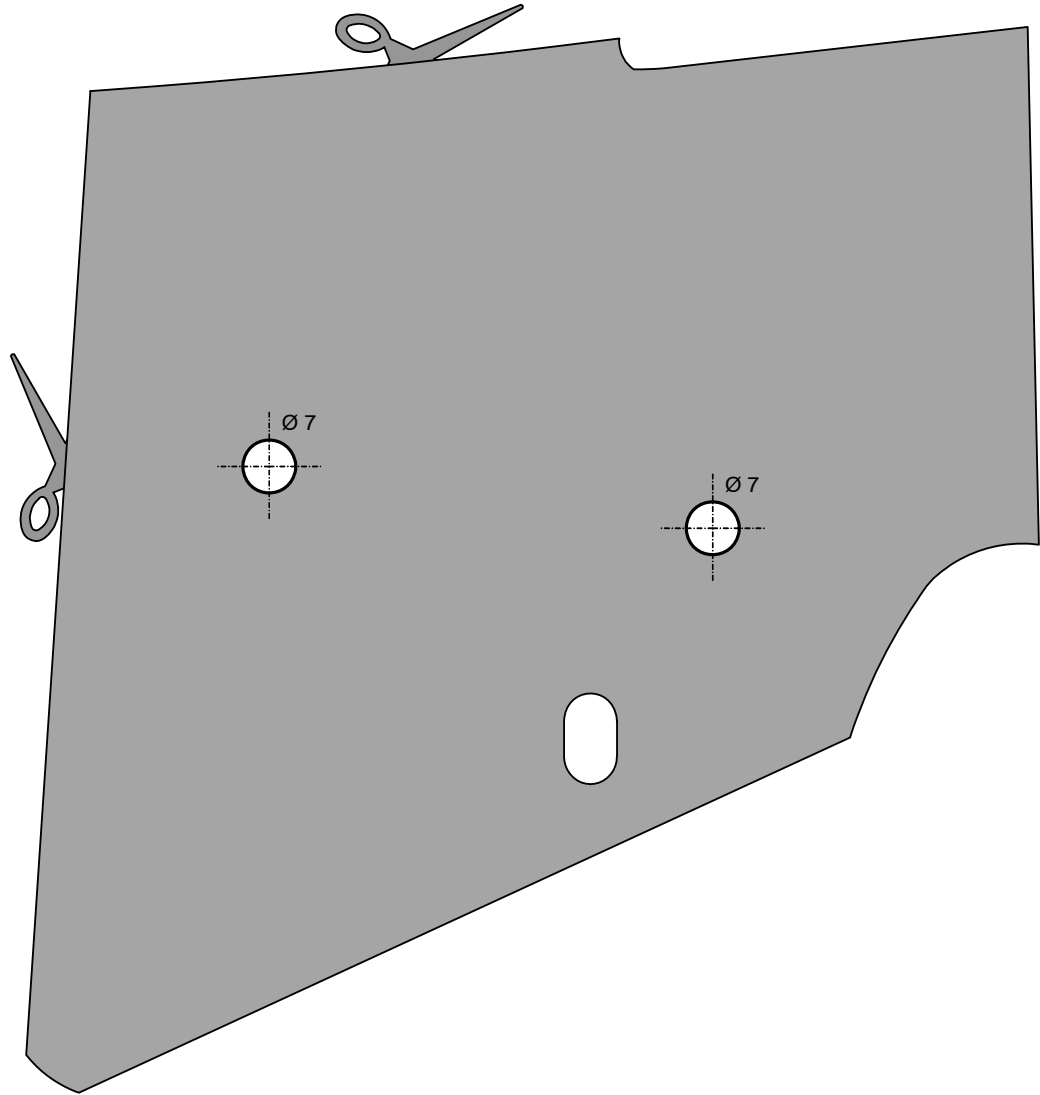

100mm



Scale 1:1

Compare size of the printed version with dimension lines.
Permitted tolerance a maximum of 2%.

Set the printer settings to "no margin" or "minimise margins" and 100% of the normal size.

100mm

0

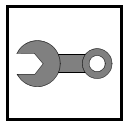

Template for Bracket A

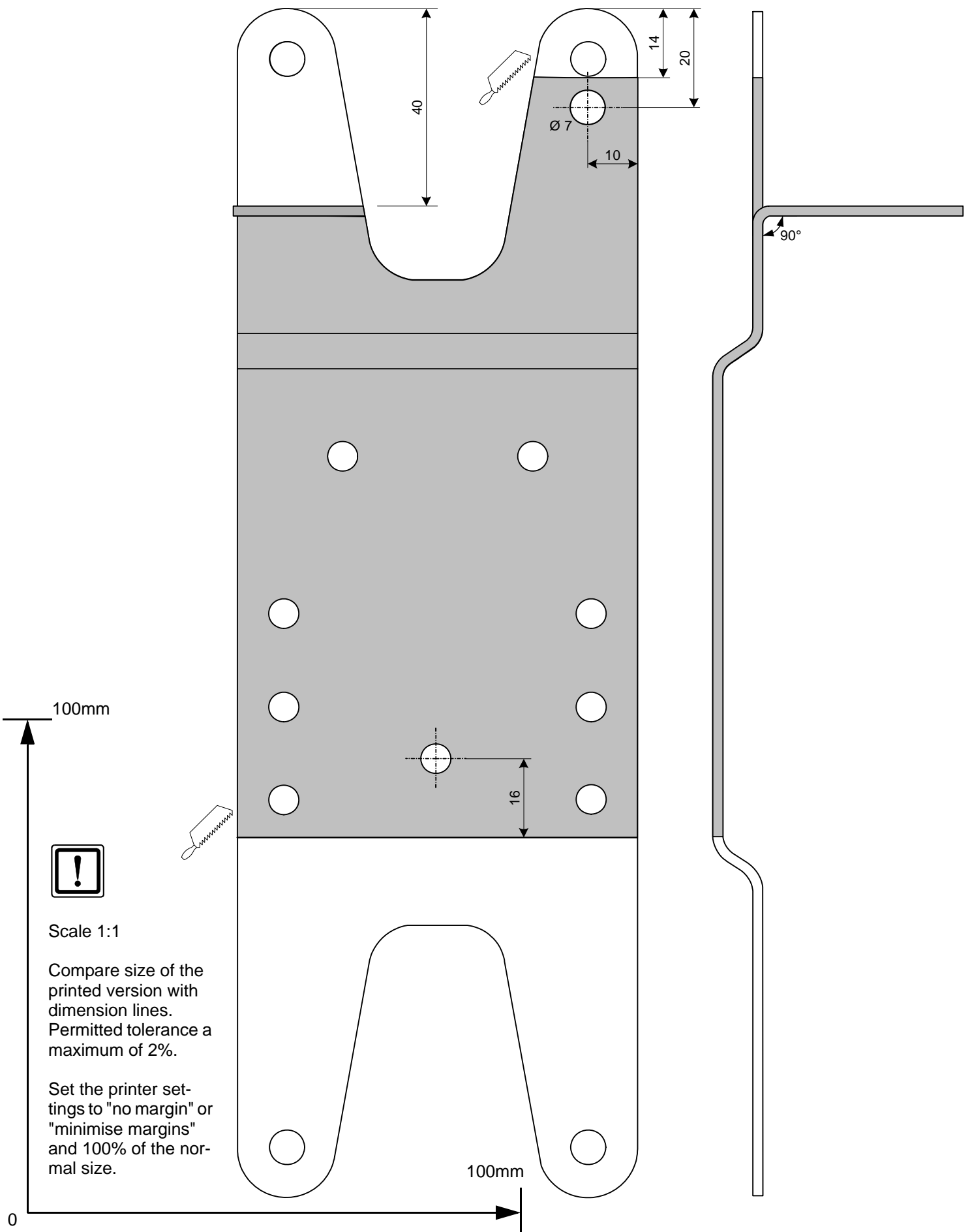



Template for Bracket B

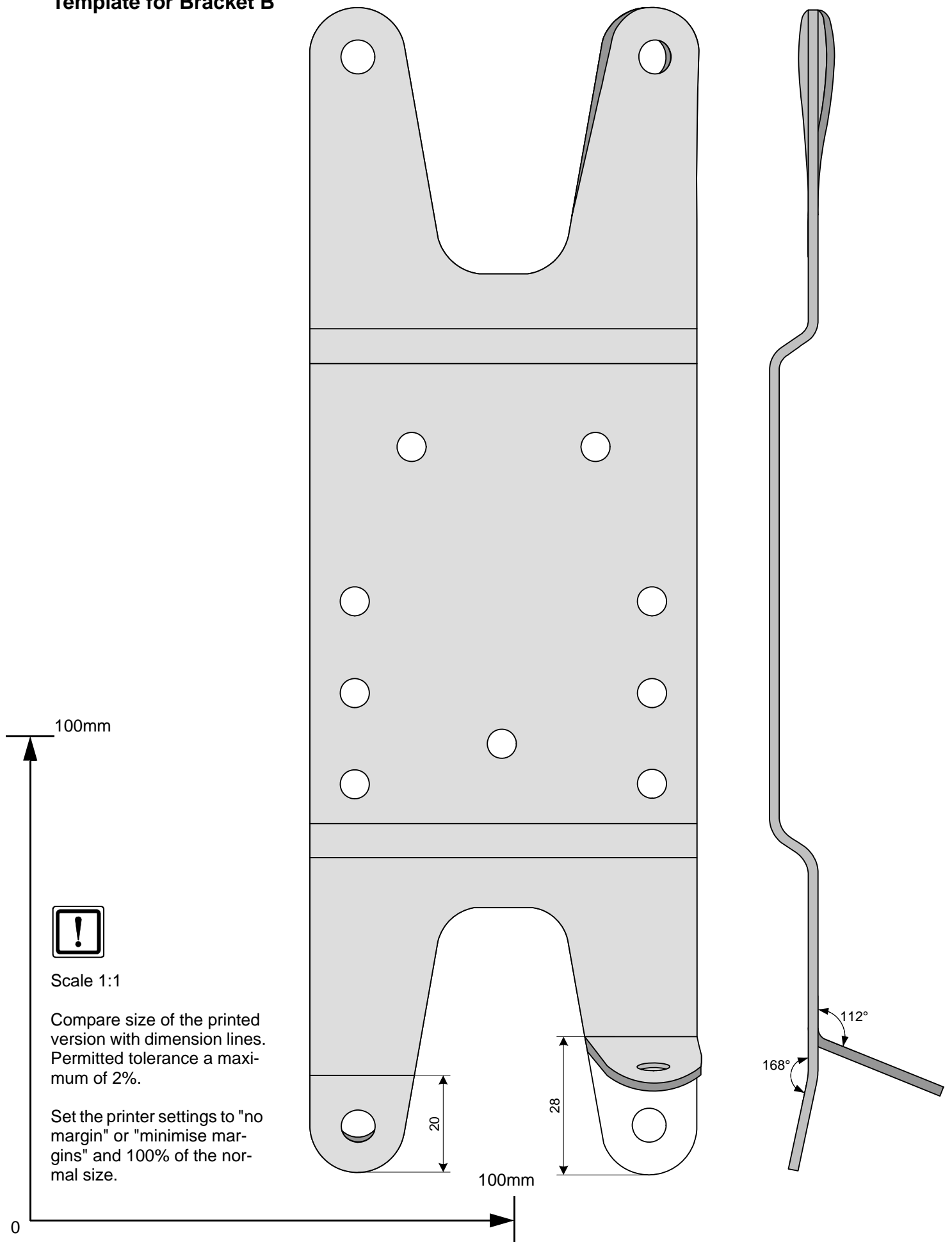

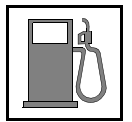

Template for Fuel Standpipe

Petrol Version A

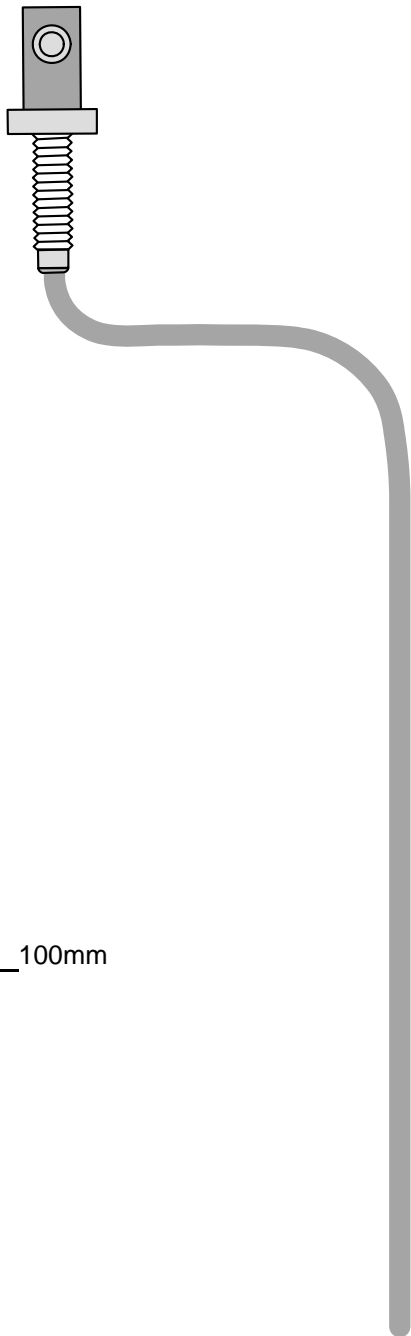

Petrol Version B
Diesel Version A

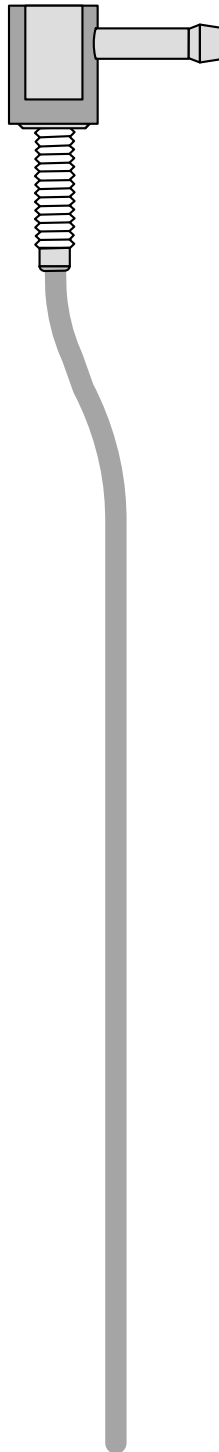

Diesel Version B

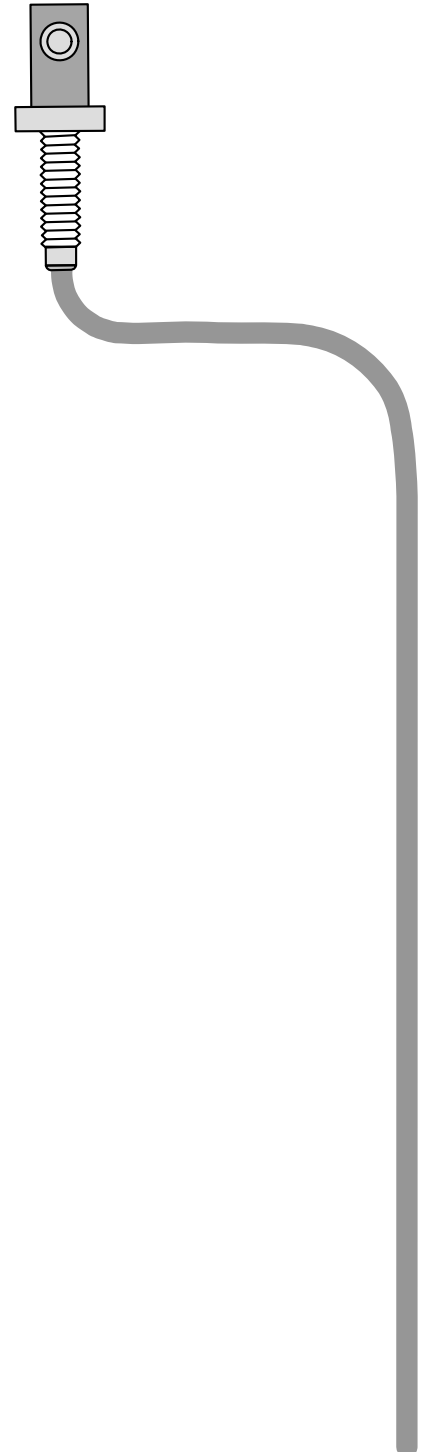

100mm



Scale 1:1

Compare size of the printed version with dimension lines.
Permitted tolerance a maximum of 2%.

Set the printer settings to "no margin" or "minimise margins" and 100% of the normal size.

100mm

0

Operating Instructions for Manual Air-Conditioning

Please remove page and add to the vehicle operating instructions.

Note:

We recommend matching the heating time to the driving time.
Heating time = driving time

Example:

For a driving time of approx. 20 min. (in one direction), we recommend not exceeding a switch-on time of 20 min.

Passenger compartment monitoring, if installed, must be deactivated in addition to the vehicle settings for the heating operation.

For instructions on deactivation, please refer to the operating instructions of the vehicle.

Before parking the vehicle, make the following settings:

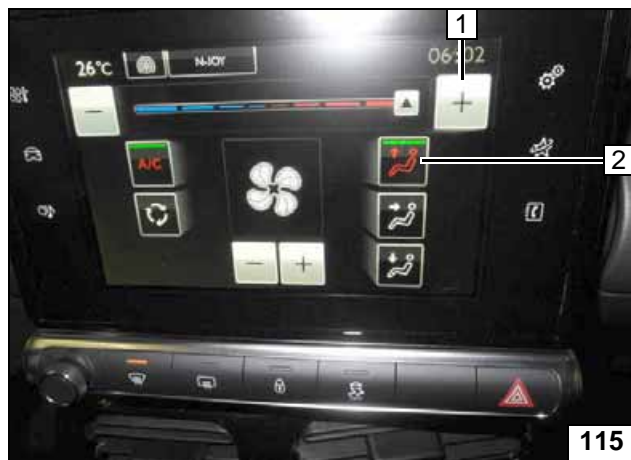

- 1 Set temperature to "max."
- 2 Air outlet faces "upward"



A/C control panel

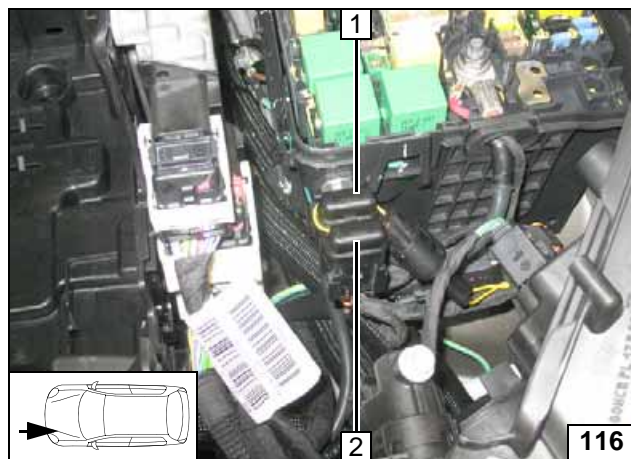

- 1 30A main fuse F2 of passenger compartment
- 2 20A heater fuse F1

Engine compartment fuses

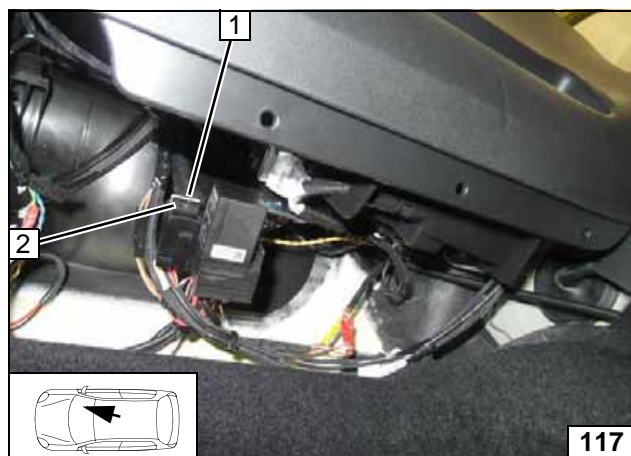

- 1 25A fan fuse F4
- 2 1A fuse F3 of heater control

Passenger compartment fuses



Operating Instructions for Automatic A/C

Please remove page and add to the vehicle operating instructions.

Note:

We recommend matching the heating time to the driving time.
 Heating time = driving time

Example:

For a driving time of approx. 20 min. (in one direction), we recommend not exceeding a switch-on time of 20 min.

Passenger compartment monitoring, if installed, must be deactivated in addition to the vehicle settings for the heating operation.

For instructions on deactivation, please refer to the operating instructions of the vehicle.

Before parking the vehicle, make the following settings:

- 1 Air outlet turned "upwards"
- 2 Set temperature on both sides to "HI"

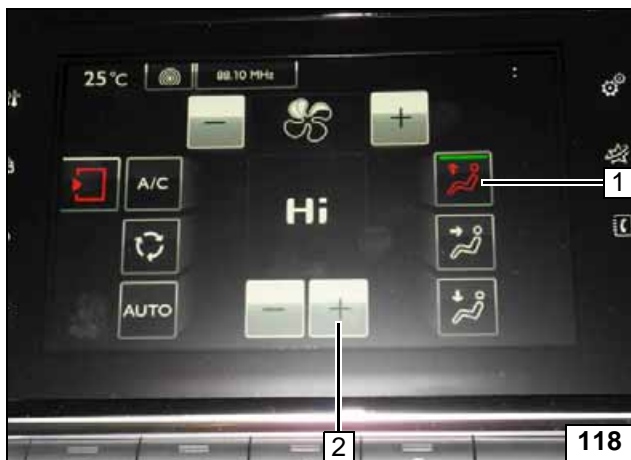

A/C control panel

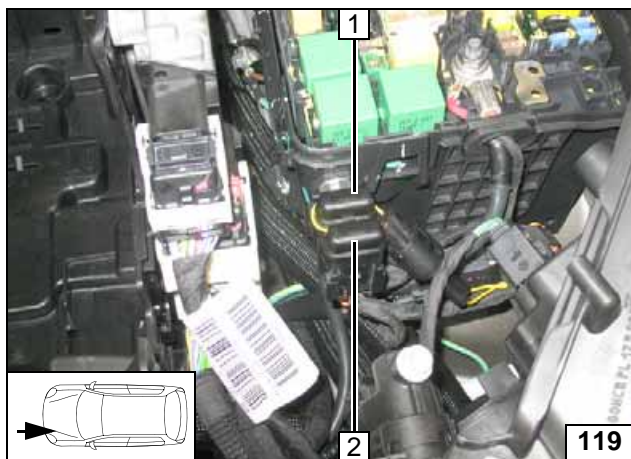

- 1 30A main fuse F2 of passenger compartment
- 2 20A heater fuse F1

Engine compartment fuses

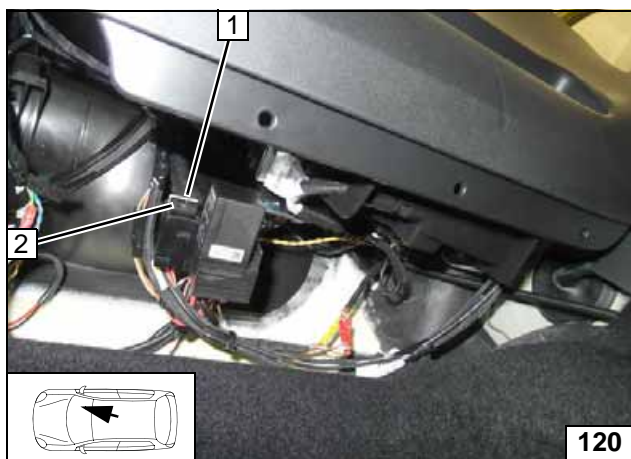

- 1 25A fan fuse F4
- 2 1A fuse F3 of heater control

Passenger compartment fuses