

Water Heater

Thermo Top Evo Parking Heater



Installation Documentation

Mitsubishi Pajero

Validity

Manufacturer	Model	Type	EG BE No. / ABE
Mitsubishi	Pajero	V80	e1 * 2001 / 116 * 0385 * ...

Motorisation	Fuel	Transmission type	Output in kW	Displacement in cm ³	Engine code
3.2 DID	Diesel	6-gear SG	118	3200	4M41
3.2 DID	Diesel	6-gear AG	125	3200	4M41
3.2 DID	Diesel	6-gear AG	147	3200	4M41

SG = manual transmission
 AG = automatic transmission

From model year 2007

Left-hand drive vehicle

Verified equipment variants: Automatic air-conditioning
 Front fog lights
 Headlight washer system
 Long wheelbase
 Euro 6 emission standard

Not verified: Manual air-conditioning
 Passenger compartment monitoring

Total installation time: about 6.5 hours

Mitsubishi Pajero

Table of Contents

Validity	1	Preparing Installation Location	13
Necessary Components	2	Preparing Heater	16
Installation Overview	2	Installing Heater	18
Information on Total Installation Time	2	Fuel	21
Information on Operating and Installation Instructions	3	Exhaust Gas	23
Information on Validity	4	Coolant Circuit	26
Technical Information	4	Combustion Air	30
Explanatory Notes on Document	4	Final Work	31
Preliminary Work	5	Operating Instructions for Automatic Air-Conditioning	32
Heater Installation Location	5		
Preparing Electrical System	6		
Electrical System	8		
Fan Controller	9		
MultiControl CAR Option	11		
Remote Option (Telestart)	11		
ThermoCall Option	12		

Necessary Components

- Basic delivery scope of *Thermo Top Evo* based on price list
- Installation kit for Mitsubishi Pajero 2007 Diesel: **1323469B**
- Heater control in accordance with price list and upon consultation with end customer
- In case of Telestart, indicator lamp in accordance with price list and in consultation with end customer

Installation instructions:

- Arrange for the vehicle to be delivered with the tank only about $\frac{1}{4}$ full.
- The installation location of the push button in case of Telestart or Thermo Call should be confirmed with the end customer.
- Depending on the space required and the vehicle manufacturer's instructions, we recommend the use of a vehicle battery with a higher electrical capacity.

Installation Overview

Legend:

1. Heater
2. Engine compartment fuse holder
3. Passenger compartment relay and fuse holder
4. Circulating pump
5. MultiControl CAR
6. Metering pump

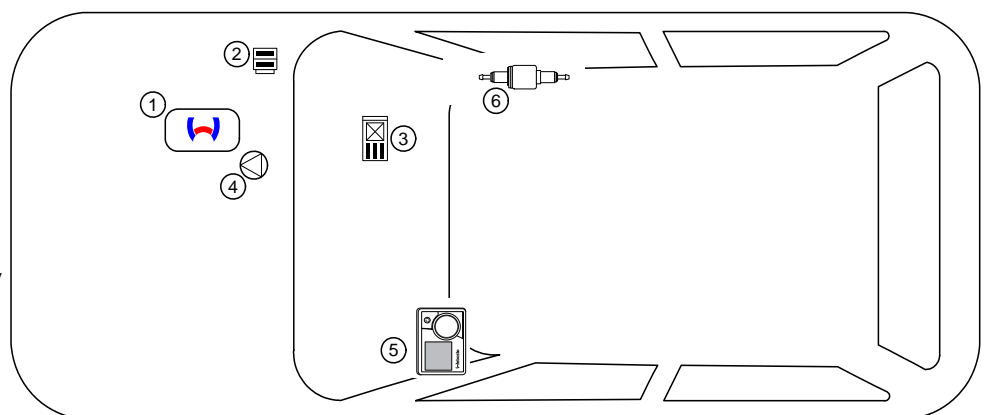

Information on Total Installation Time

The total installation time includes the time needed for mounting and demounting the vehicle-specific components, the heater specific installation time and all other times required for the system integration and initial start-up of the heater.

The total installation time may vary for vehicle equipment other than provided.

Information on Operating and Installation Instructions

1 Important information (not complete)

1.1 Installation and repair



The improper installation or repair of Webasto heating and cooling systems can cause fire or the leakage of deadly carbon monoxide, leading to serious injury or death.



To install and repair Webasto heating and cooling systems you need to have completed a special company training course and have the appropriate technical documentation, special tools and special equipment.



Installation and repair may ONLY be carried out by persons trained and certified in a Webasto training course. NEVER try to install or repair Webasto heating or cooling systems if you have not completed a Webasto training course, you do not have the necessary technical skills and you do not have the technical documentation, tools and equipment available to ensure that you can complete the installation and repair work properly.

Only use genuine Webasto parts. See the Webasto air and water heaters accessories catalogue for this purpose.

1.2 Operation

To ensure safe operation, we recommend having the heater checked every two years by an authorised Webasto dealer, especially when used over a long period and/or under extreme environmental conditions.

Do not operate the heater in closed rooms due to the danger of poisoning and suffocation.

Always switch off the heater before refuelling.

The heater may only be used with the prescribed fuel diesel (DIN EN 590) or petrol (DIN EN 228).

The heater may not be cleaned with a high-pressure cleaner.

1.3 Please note

ALWAYS follow all Webasto installation and operating instructions and observe all warnings.

To become familiar with and understand all functions and properties of the heater, the operating instructions must be read carefully and observed at all times.

For proper, safe installation and repair work, the installation instructions with all warnings and safety information must be carefully read and observed at all times. Please always contact a workshop authorised by Webasto for all installation and repair work.

Important

Webasto shall assume no liability for defects, damage and injuries resulting from a failure to observe the installation, repair and operating instructions of the information contained in them.

This liability exclusion particularly applies to improper installations and repairs, installations and repairs by untrained persons or in the case of a failure to use genuine spare parts.

The liability due to culpable disregard to life, limb or health and due to damage or injuries caused by a wilful or reckless breach of duty remain unaffected, as does the obligatory product liability.

Installation should be carried out according to the general, standard rules of technology. Unless specified otherwise, fasten hoses, lines and wiring harnesses to original vehicle lines and wiring harnesses using cable ties. Insulate loose wire ends and tie back. Connectors on electronic components have to audibly click into place during installation.

Sharp edges should be fitted with rub protection. Spray unfinished body areas, e.g. drilled holes, with anti-corrosion wax (Tectyl 100K).

Observe the instructions and guidelines of the respective vehicle manufacturer for demounting and mounting vehicle specific components!

The initial startup is to be executed with the Webasto Thermo Test Diagnosis.

When installing a programmable control module (e.g. a PWM Gateway), the corresponding settings must be checked or adjusted.

2 Statutory regulations governing installation

Guidelines	Thermo Top Evo
Heating Directive ECE R122	E1 00 0258
EMC Directive ECE R10	E1 04 5627

Note

The regulations of these guidelines are binding in the scope of the Directive 70/156/EEC and/or 2007/46/EC (for new vehicle models from 29/04/2009) and should also be observed in countries in which there are no special regulations.

Important

Failure to follow the installation instructions will result in the invalidation of the type approval for the heater and therefore invalidation of the general **homologation of the vehicle**.

Note

The heater is licensed in accordance with paragraph 19, section 3, No. 2b of the StVZO (German Road Traffic Licensing Authority).

2.1 Excerpt from ECE regulation 122 (heating system) paragraph 5 for the installation of the heater

Beginning of excerpt.

ANNEX VII

REQUIREMENTS FOR COMBUSTION HEATERS AND THEIR INSTALLATION

1. GENERAL REQUIREMENTS

1.7.1. A clearly visible tell-tale in the operator's field of view shall inform when the combustion heater is switched on or off.

2. VEHICLE INSTALLATION REQUIREMENTS

2.1. Scope

2.1.1. Subject to paragraph 2.1.2. combustion heaters shall be installed according to the requirements of this Annex.

2.1.2. Vehicles of category O having liquid fuel heaters are deemed to comply with the requirements of this Annex.

2.2. Positioning of heater

2.2.1. Body sections and any other components in the vicinity of the heater must be protected from excessive heat and the possibility of fuel or oil contamination.

2.2.2. The combustion heater shall not constitute a risk of fire, even in the case of overheating. This requirement shall be deemed to be fulfilled if the installation ensures an adequate distance to all parts and suitable ventilation, by the use of fire resistant materials or by the use of heat shields.

2.2.3. In the case of M2 and M3 vehicles, the heater must not be positioned in the passenger compartment. However, an installation in an effectively sealed envelope which also complies with the conditions in paragraph 2.2.2 may be used.

2.2.4. The label referred to in paragraph 1.4 or a duplicate, must be positioned so that it can be easily read when the heater is installed in the vehicle.

2.2.5. Every reasonable precaution should be taken in positioning the heater to minimise the risk of injury and damage to personal property.

2.3. Fuel supply

2.3.1. The fuel filler must not be situated in the passenger compartment and must be provided with an effective cap to prevent fuel spillage.

2.3.2. In the case of liquid fuel heaters, where a supply separate to that of the vehicle is provided, the type of fuel and its filler point must be clearly labelled.

2.3.3. A notice, indicating that the heater must be shut down before refuelling, must be affixed to the fuelling point. In addition a suitable instruction must be included in the manufacturer's operating manual.

2.4. Exhaust system

2.4.1. The exhaust outlet must be located so as to prevent emissions from entering the vehicle through ventilators, heated air inlets or opening windows.

2.5. Combustion air inlet

2.5.1. The air for the combustion chamber of the heater must not be drawn from the passenger compartment of the vehicle.

2.5.2. The air inlet must be so positioned or guarded that blocking by rubbish or luggage is unlikely.

2.6. Heating air inlet

2.6.1. The heating air supply may be fresh or recirculated air and must be drawn from a clean area not likely to be contaminated by exhaust fumes emitted either by the propulsion engine, the combustion heater or any other vehicle source.

2.6.2. The inlet duct must be protected by mesh or other suitable means.

2.7. Heating air outlet

2.7.1. Any ducting used to route the hot air through the vehicle must be so positioned or protected that no injury or damage could be caused if it were to be touched.

2.7.2. The air outlet must be so positioned or guarded that blocking by rubbish or luggage is unlikely.

End of excerpt.

In multilingual versions the German language is binding.

Mitsubishi Pajero

Information on Validity

This installation documentation applies to Mitsubishi Pajero Diesel vehicles - for validity, see page 1 - from model year 2007 and later, assuming technical modifications to the vehicle do not affect installation, any liability claims excluded. Depending on the vehicle version and equipment, modifications may be necessary during installation with respect to this 'installation documentation'.

Vehicle and engine types, equipment variants and other specifications not listed in this installation documentation have not been tested. However, installation according to this installation documentation may be possible.

Technical Information

Special Tools

- Hose clamp pliers for auto-tightening hose clamps
- Hose clamp pliers for Clic hose clamps of type W
- Automatic wire stripper 0.2 - 6mm²
- Crimping pliers for cable lug / tab connector 0.5 - 6mm²
- Torque wrench for 2.0 - 10 Nm
- Hose clamping pliers
- Metric thread-setter kit
- Deep-hole marker
- Webasto Thermo Test Diagnosis with current software

Dimensions

- All dimensions are in mm.















Tightening torque values

- Tightening torque values of 5x13 heater bolts and 5x11 heater stud bolts = 8Nm.
- Tightening torque value of 5x15 water connection piece retaining plate bolt = 7Nm.
- Tighten other bolt connections in accordance with manufacturer's instructions or in accordance with state-of-the-art-technology.

Explanatory Notes on Document

You will find an identification mark on the outside top right corner of the page in question to provide you with a quick overview of the individual working steps.

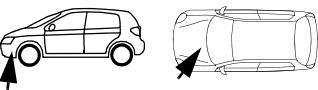
Special features are highlighted using the following symbols:

Mechanical System		Specific risk of injury or fatal accidents.	
Electrical System		Specific risk due to electrical voltage.	
Coolant Circuit		Specific risk of damage to components.	
Combustion Air		Specific risk of fire and explosion.	
Fuel		Reference to general installation instructions of the Webasto components or to the manufacturer's vehicle-specific documents.	
Exhaust Gas		Reference to a special technical feature.	
Software		The arrow in the vehicle icon indicates the position on the vehicle and the viewing angle.	
		Tightening torque according to the manufacturer's vehicle-specific documents.	

Mitsubishi Pajero

Preliminary Work

Vehicle

- Open the fuel tank cap.
- Ventilate the fuel tank.
- Close the fuel tank cap again.
- Depressurise the cooling system.
- Disconnect the earth connections of both batteries.
- Remove the positive wire of the additional battery.
- Remove the entire battery with its box and carrier.
- Remove the entire air filter with the intake hose and the lower section.
- Remove the engine cover.
- Detach the diesel filter from the firewall.
- Remove the protective pan under the transmission.
- Remove the underride protection in the centre (if present).
- Remove the footwell trim on the front passenger's side.
- Remove the glove box.
- Remove the A/C control panel (unclip).
- In case of MultiControl CAR, remove the footwell trim on the driver's side.
- In case of MultiControl CAR, detach the lower instrument panel trim on the driver's side.

Heater

- Remove years that do not apply from the type and duplicate label.
- Attach the duplicate label (type label) visibly in the appropriate place in the engine compartment.



Heater Installation Location

1 Heater

Installation location

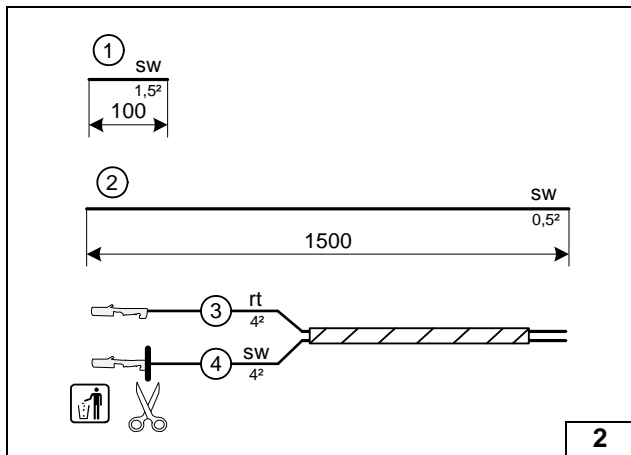
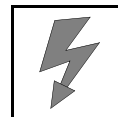

Preparing Electrical System

Wire sections retain their numbering in the entire document.

Produce all following electrical connections as shown in the wiring diagram.

Pull wire section ② into provided protective sleeving.

- ③ Red (rt) wire of fan wiring harness
- ④ Black (sw) wire of fan wiring harness



Cutting wires to length/ assigning wires

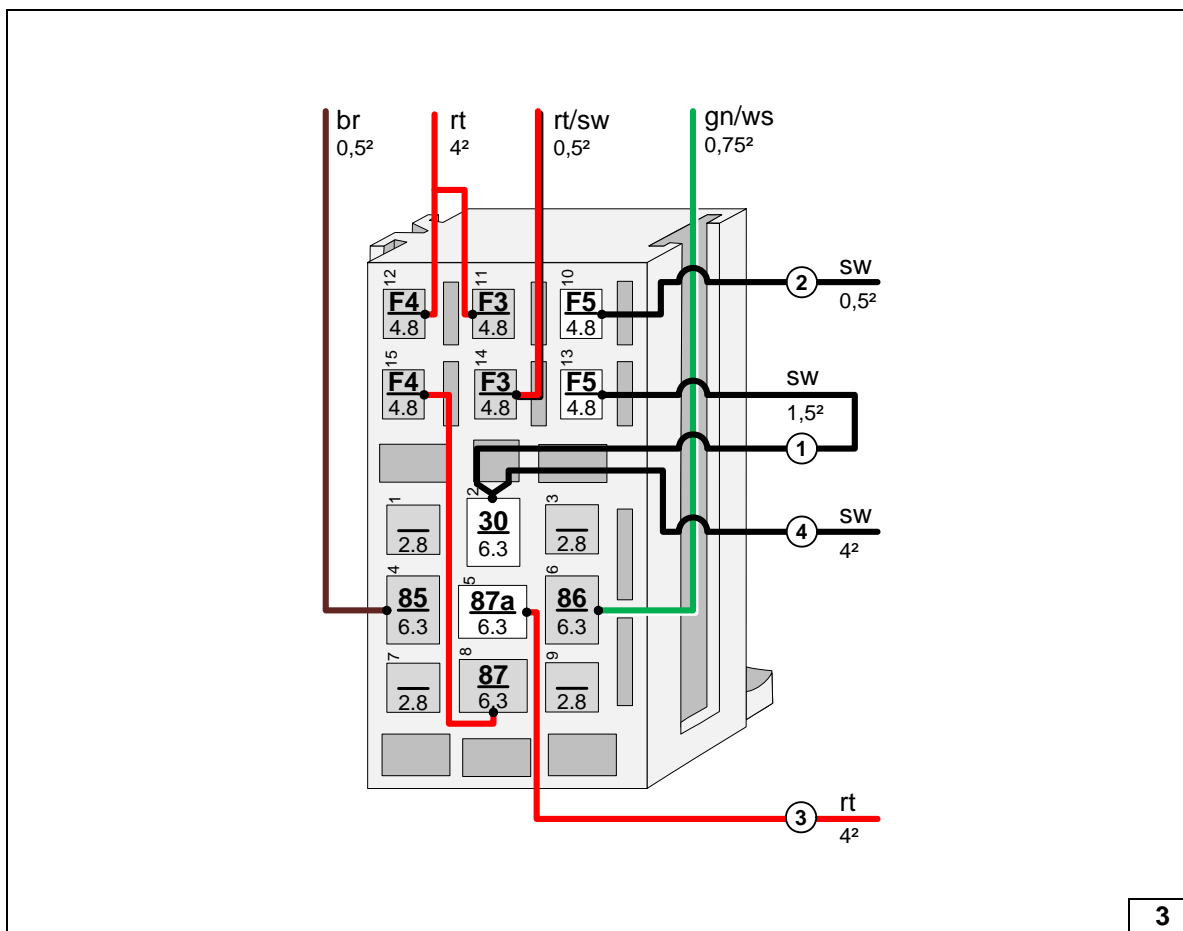

Installing wires

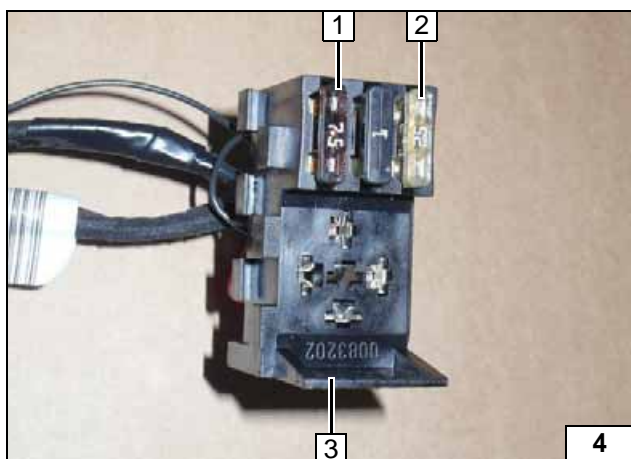

- 1 7.5A fuse F5
- 2 25A fuse F4
- 3 Passenger compartment relay and fuse holder

Inserting fuses

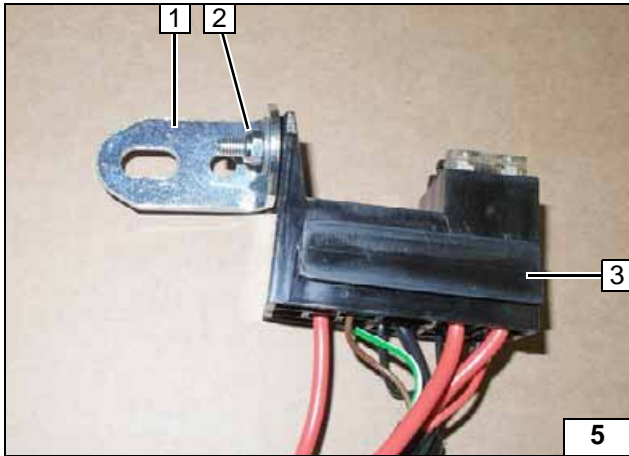
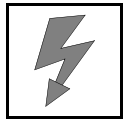

- 1 Angle bracket
- 2 M5x16 bolt, large diameter washer [2x], nut
- 3 Passenger compartment relay and fuse holder

Installing angle bracket

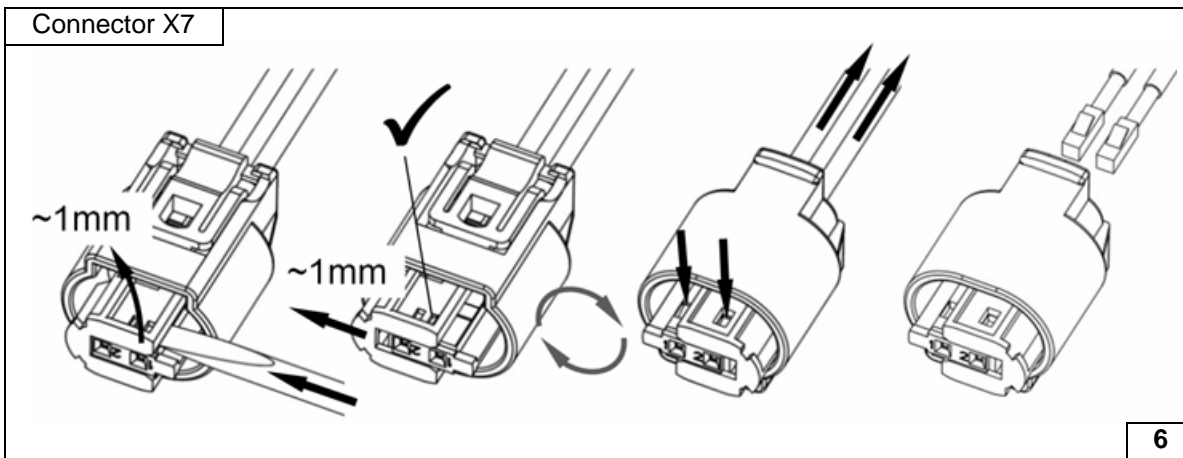

Dismantling metering pump connector



Electrical System

Earth wire

- 1 Earth wire on original vehicle earth support point

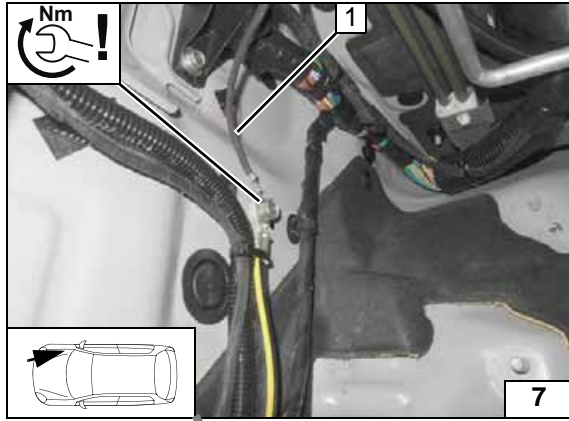

Engine compartment fuse holder

- 1 Angle bracket
- 2 Original vehicle bolt
- 3 M5x16 bolt, large diameter washer [2x], retaining plate of fuse holder, nut
- 4 Fuses F1-2

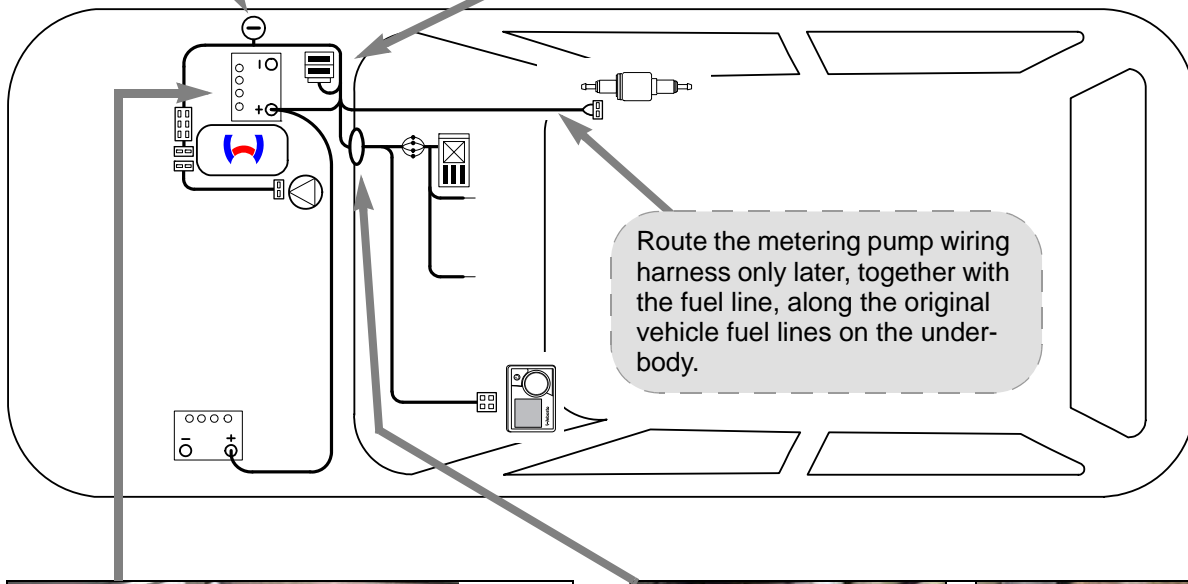
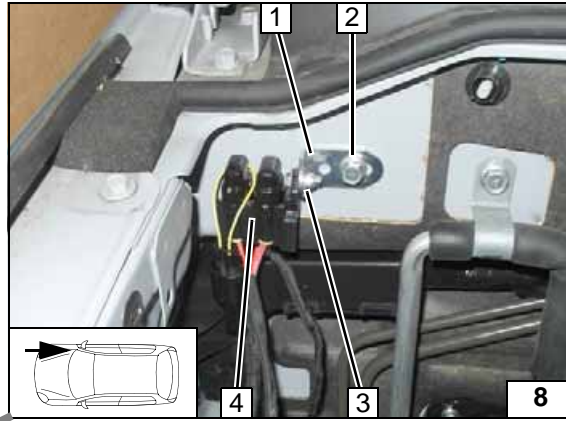

Wiring harness routing diagram

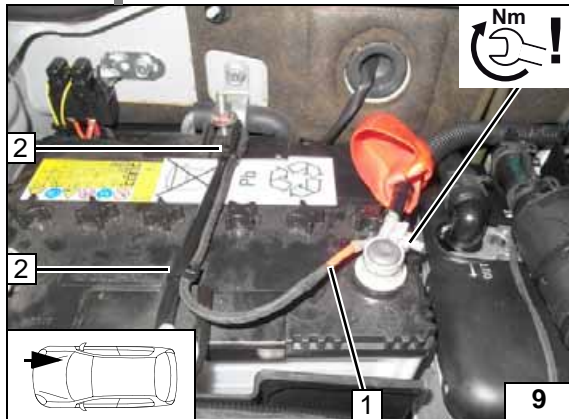

Positive wire

- 1 Positive wire on positive battery terminal
- 2 Cable tie [2x]

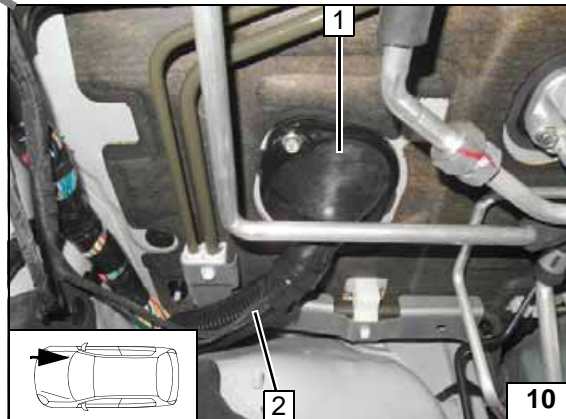

Wiring harness pass through

- 1 Protective rubber plug
- 2 Heater wiring harnesses, heater control





Fan Controller

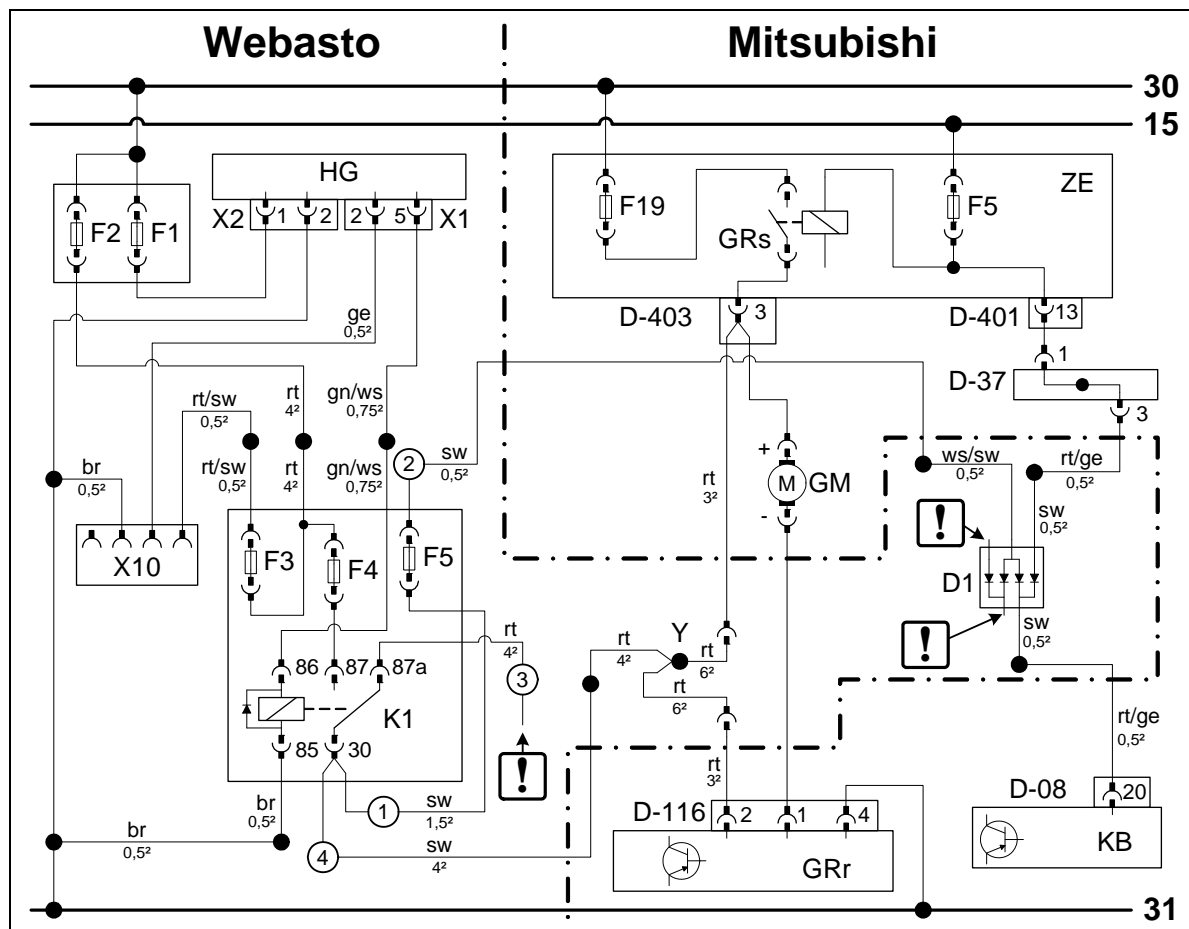

Wiring diagram

Webasto components		Vehicle components		Colours and symbols	
HG	TT-Evo heater	ZE	Central electrical box	rt	red
X1	6-pin heater connector	F5	7.5A fuse	sw	black
X2	2-pin heater connector	F19	30A fuse	ge	yellow
F1	20A fuse	GRs	Fan relay	gn	green
F2	30A fuse	D-401	14-pin connector of ZE	br	brown
X10	4-pin connector of heater control	D-403	6-pin connector of ZE	ws	white
F3	1A fuse	D-405	2-pin connector of ZE		
F4	25 A fuse	D-37	Connector		
F5	7.5A fuse	GM	Fan motor		
K1	Fan relay	KB	A/C control panel		
D1	Diode group	D-08	36-pin connector of KB		
Y	Power adapter	GRr	Fan controller		
		D-116	4-pin connector of GRr		
					Insulate wire end and tie back
				X	Cutting point
					Wiring colours may vary.

Legend

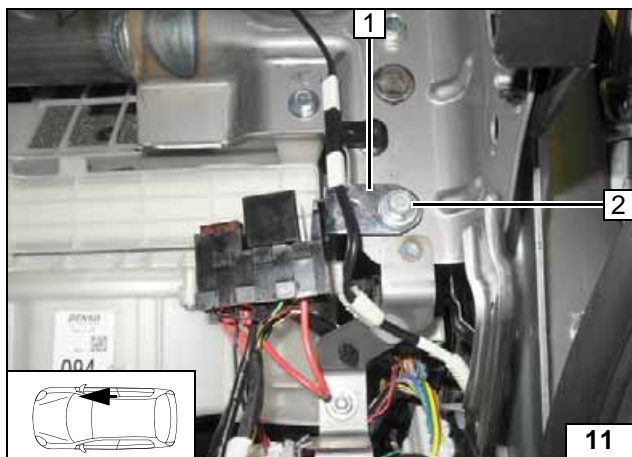

- 1 Angle bracket
- 2 Original vehicle bolt, 5mm shim

Installing passenger compartment relay and fuse holder

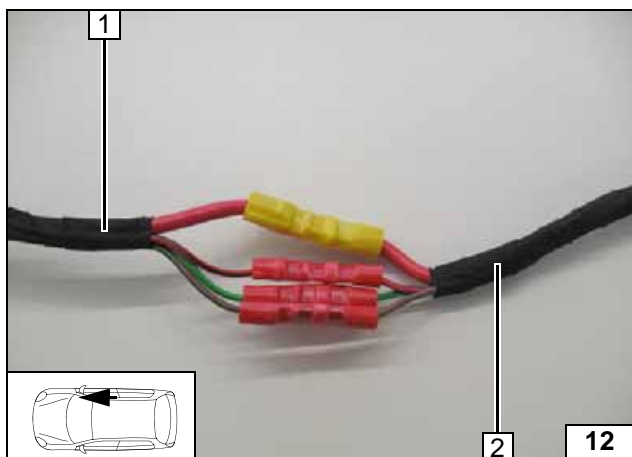

- 1 Wiring harness of passenger compartment relay and fuse holder
- 2 Heater wiring harness

Connecting same colour wires of wiring harnesses

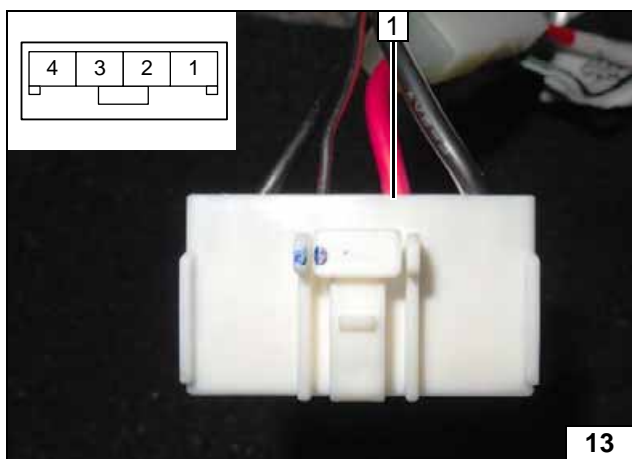

- 1 4-pin connector D-116, pin 2

Wire-side view of fan controller connector D-116

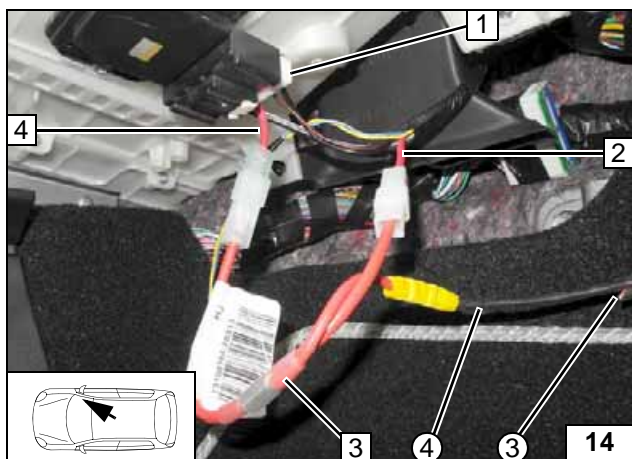

Connection to 4-pin connector D-116 1 from fan controller.

- 2 Red (rt) wire of ZE connector D403, pin 3
- 3 Power adapter
- 4 Red (rt) wire of 4-pin connector D-116, pin 2
- ③ Insulate and tie back red (rt) wire from K1/87a of fan wiring harness
- ④ Black (sw) wire of K1/30, fan wiring harness



Connecting fan controller

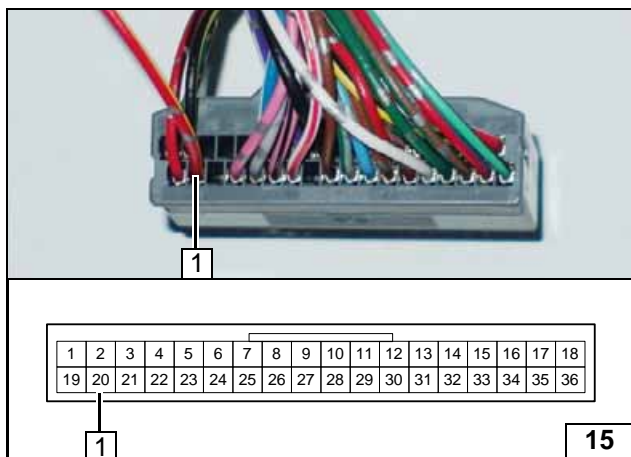
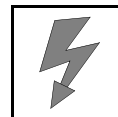

1 36-pin connector D-08/pin 20

Wire-side view of A/C control panel connector D-08

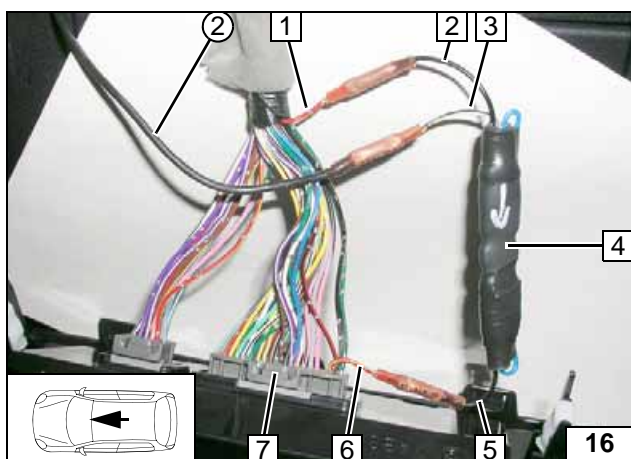

Connection to 36-pin connector D-08 7 on A/C control panel. Insulate blue (bl) wires of diode D1 [2x] and tie back!

- 1 Red/yellow (rt/ge) wire of connector D-37, pin 3
- 2 Black (sw) wire on anode side
- 3 White/black (ws/sw) wire on anode side
- 4 Diode group D1
- 5 Black (sw) wire on cathode side
- 6 Red/yellow (rt/ge) wire of 36-pin connector D-08, pin 20
- ② Black (sw) wire of fuse F5

Connecting connector D-08 of A/C control panel

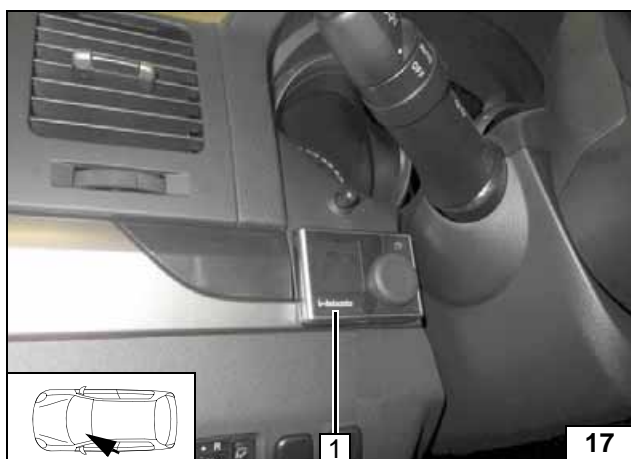

MultiControl CAR Option

- 1 MultiControl CAR

Installing MultiControl CAR

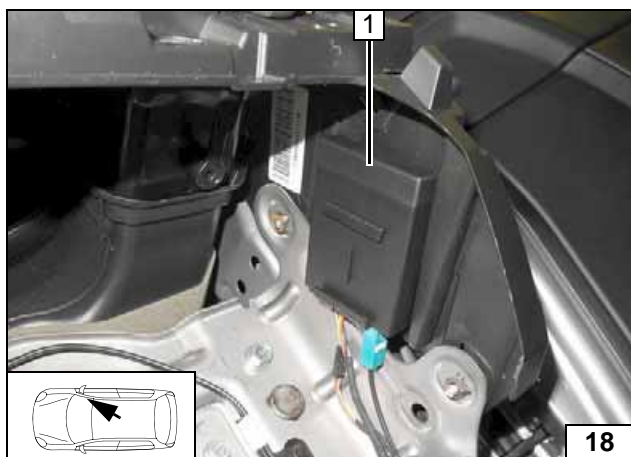

Remote Option (Telestart)

Fasten receiver 1 with double-sided adhesive tape.

Installing receiver

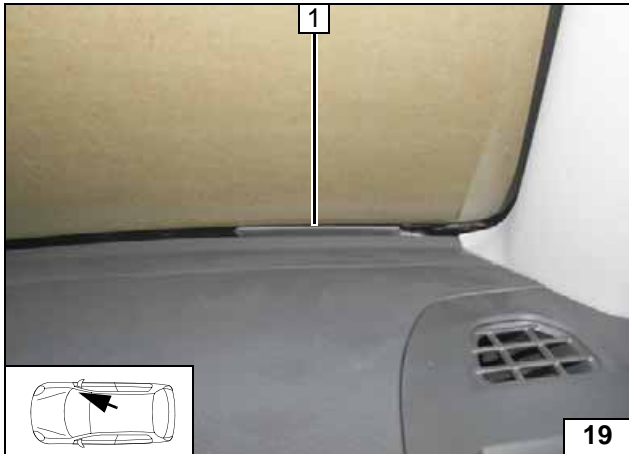
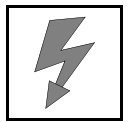

1 Aerial

Installing aerial

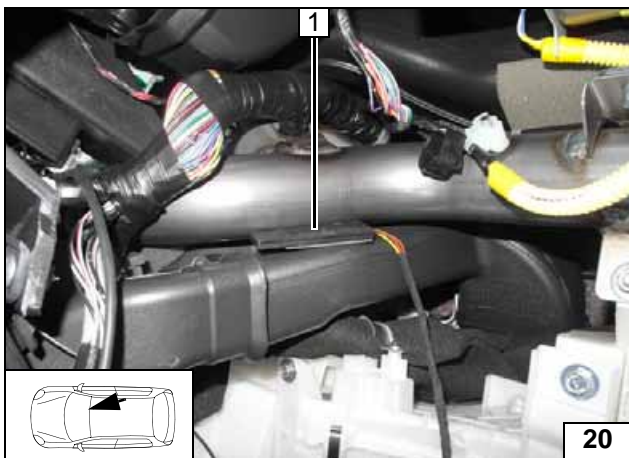

Temperature sensor T100 HTM

Fasten temperature sensor 1 with double-sided adhesive tape.



Installing temperature sensor

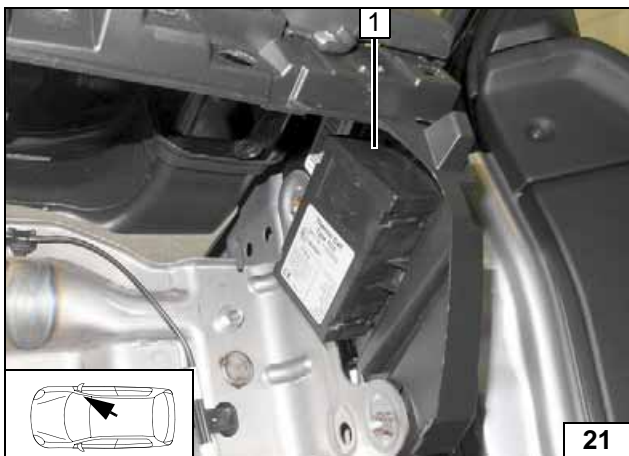

ThermoCall Option

Fasten receiver 1 with double-sided adhesive tape.



Installing receiver

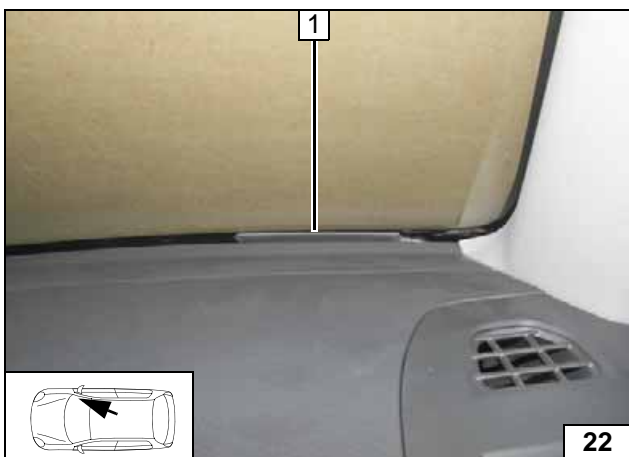

1 Aerial (optional)

Installing aerial

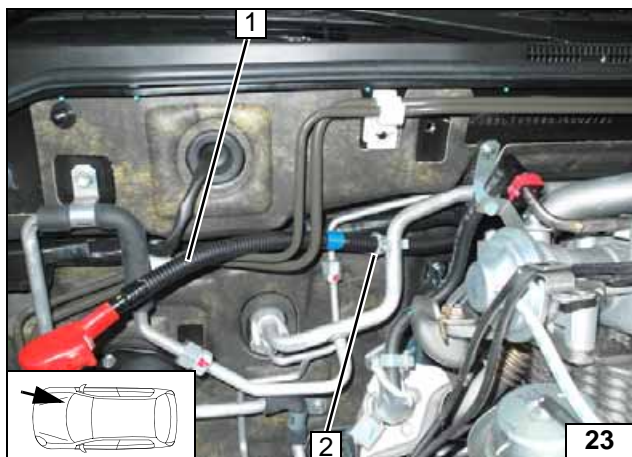
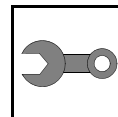

Preparing Installation Location

Route original vehicle positive cable 1 behind the fuel line. Position bracket 2.



Routing original vehicle positive cable

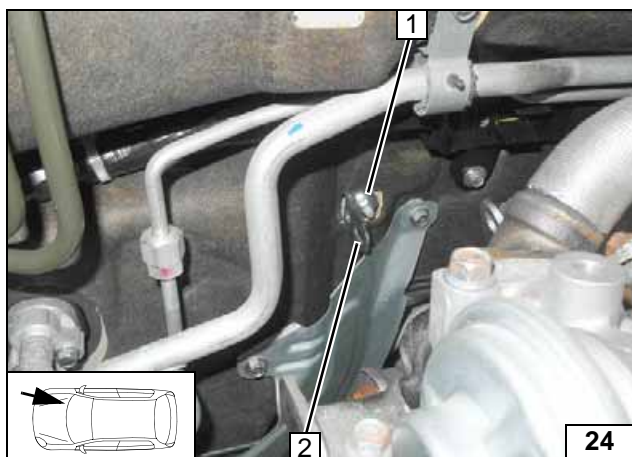

- 1 Flanged nut on original vehicle stud bolt
- 2 Angle bracket

Installing angle bracket

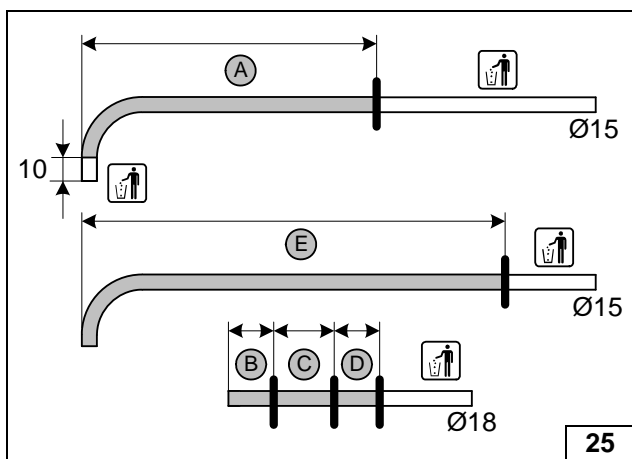

- A = 500
- B = 60
- C = 90
- D = 75
- E = 700

Cutting hoses to length/ assigning hoses

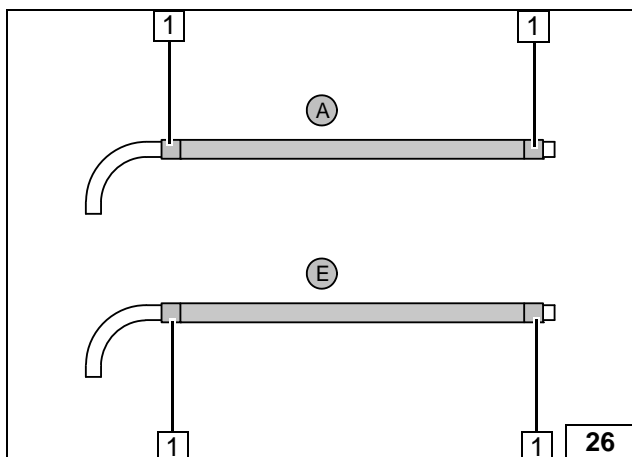

Push braided protection hoses onto hoses A and E and cut to length. Cut heat shrink plastic tubing to size.



- 1 50 mm long heat shrink plastic tubing [4x]

Preparing hose A

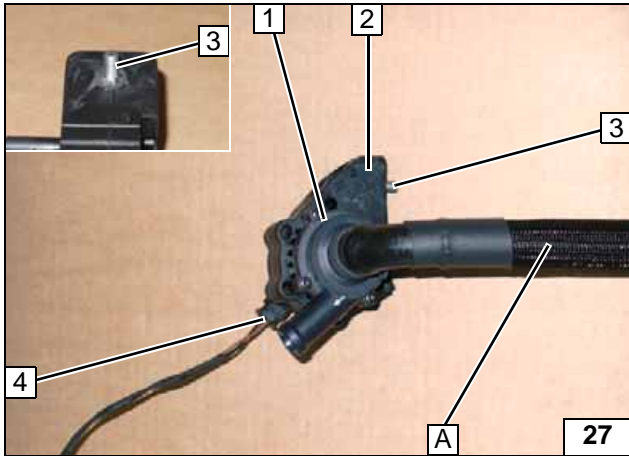

- 1 Circulating pump
- 2 Circulating pump mount
- 3 M6X25 bolt, pin lock
- 4 Connector of circulating pump wiring harness

Premounting circulating pump

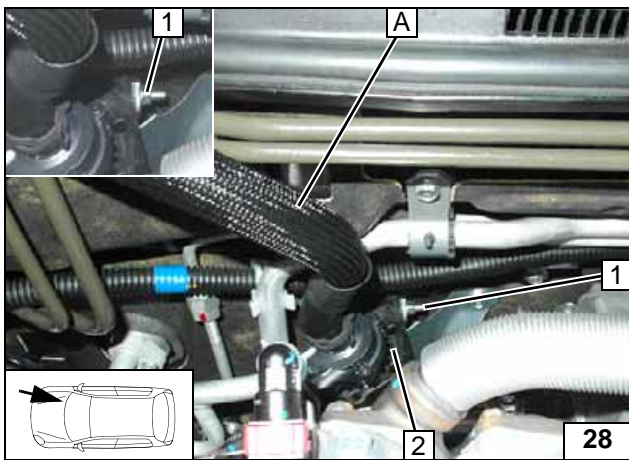

- 1 M6x25 bolt, flanged nut on angle bracket
- 2 Circulating pump mount

Installing circulating pump

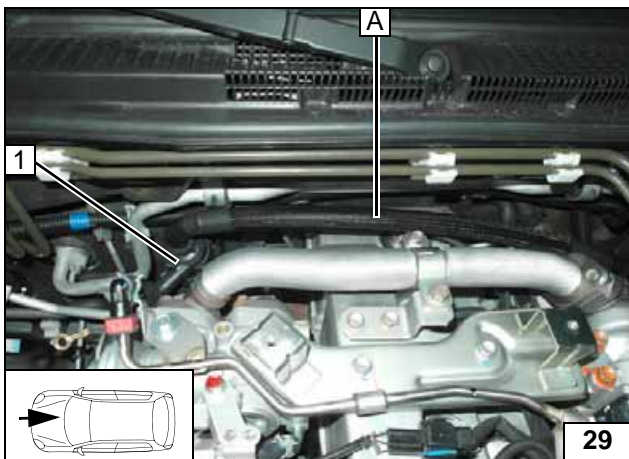

- 1 Circulating pump

Routing hose A

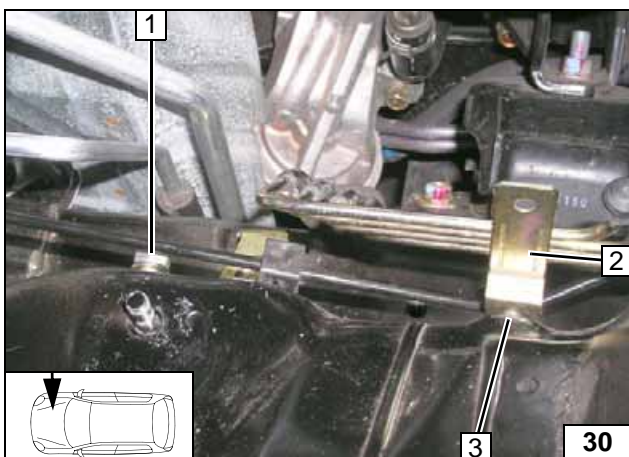

Detach original vehicle M8 bolt of line holder 2 in position 3!

- 1 M8x20 bolt, spring lockwasher, washer



Loosely premounting bracket bolts

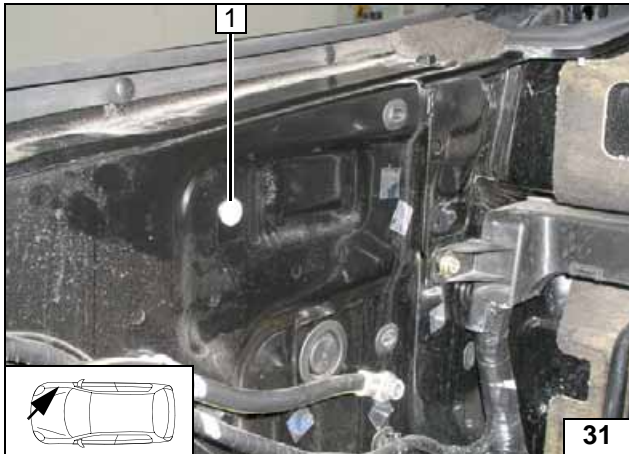

Remove adhesive label, drill out hole to 9.1 mm dia. and mount rivet nut 1.



Fastening point of retaining strut



1 Remove bolt of original vehicle earth support point

Unscrewing earth wire

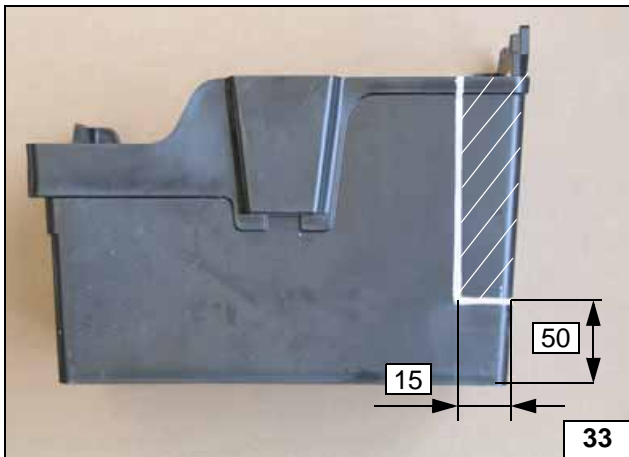

Cut away shaded area!



Cutting out battery box

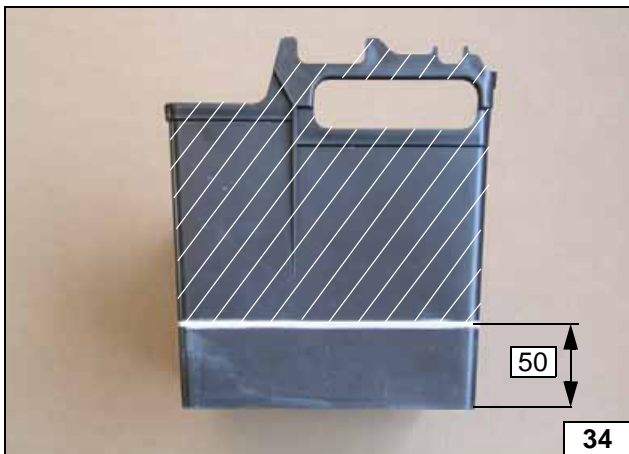

Cut away shaded area!



Cutting out battery box

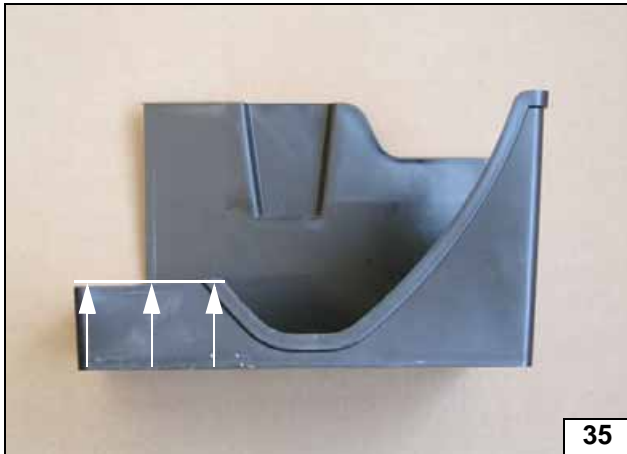

Cutting out battery box

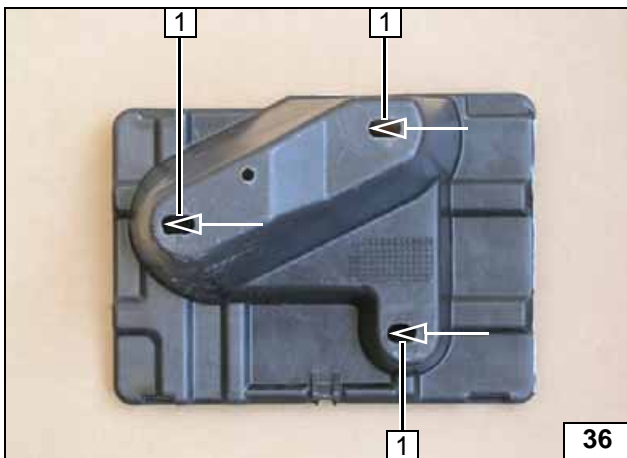

Enlarge fastening holes 1 [3x] to approx. 15 mm in direction of arrow.



Preparing battery carrier

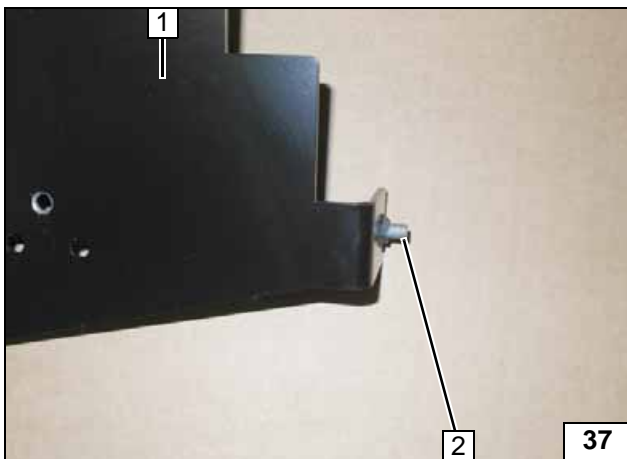

- 1 Bracket
- 2 M6x12 bolt, pin lock at existing hole

Installing bolt

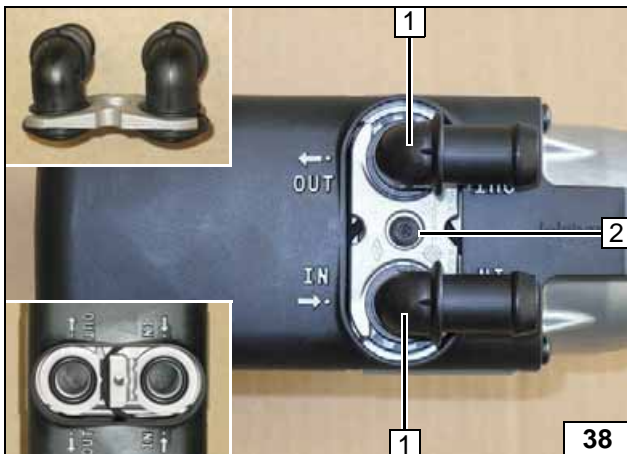

Preparing Heater

- 1 Water connection piece, sealing ring [2x each]
- 2 5x15 self-tapping bolt, retaining plate of water connection piece



Installing water connection piece

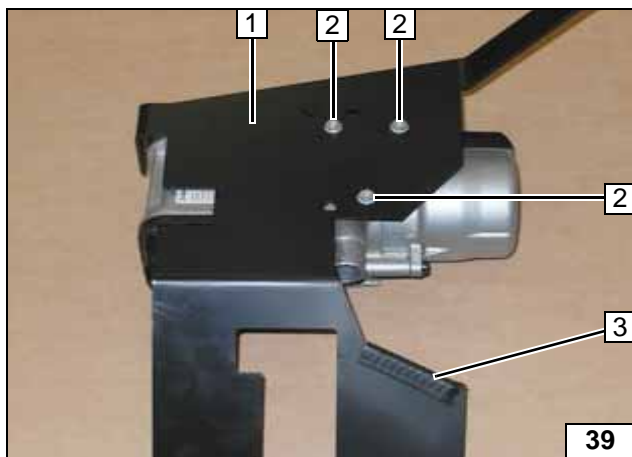

- 1 Bracket
- 2 5x13 self-tapping bolt [3x]
- 3 50mm edge protection

Premounting bolts loosely

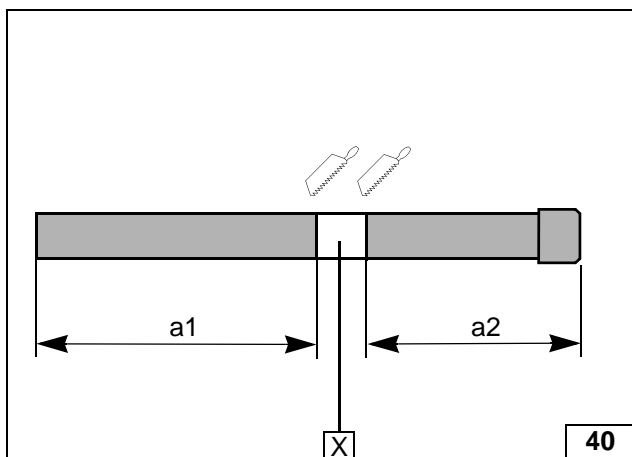

- a1 = 600
- a2 = 520

X =

Cutting to length/assigning exhaust pipe

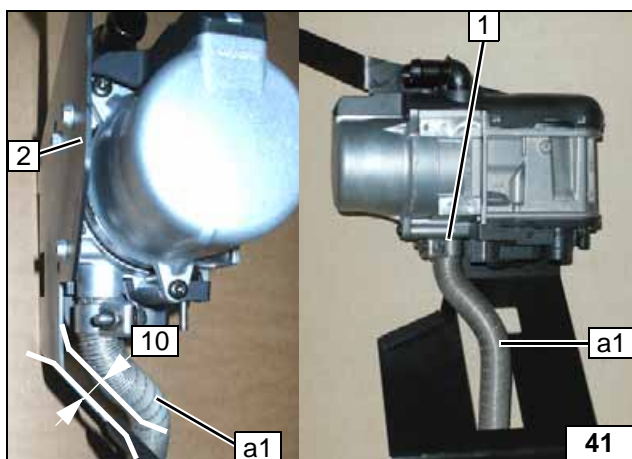

- 1 Hose clamp
- 2 Bracket



Premounting exhaust pipe a1



- 1 Flexible tube insulation

Sliding on insulation of exhaust tube

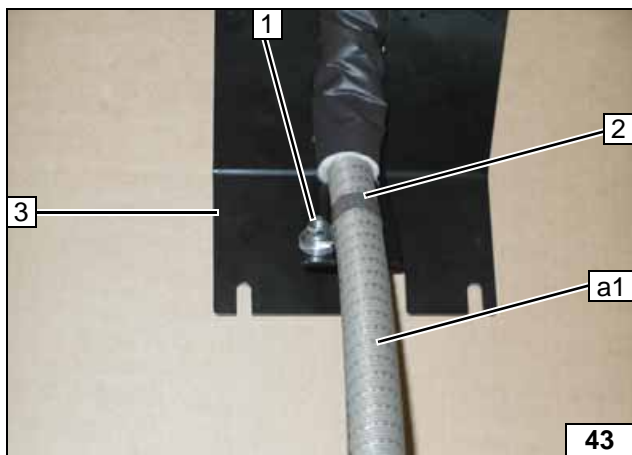
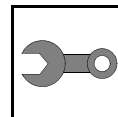

Insert a 5mm shim between bracket **3** and p-clamp **2**.

- 1** M6x20 bolt, 5mm shim, flanged nut at existing hole



Fastening exhaust pipe a1

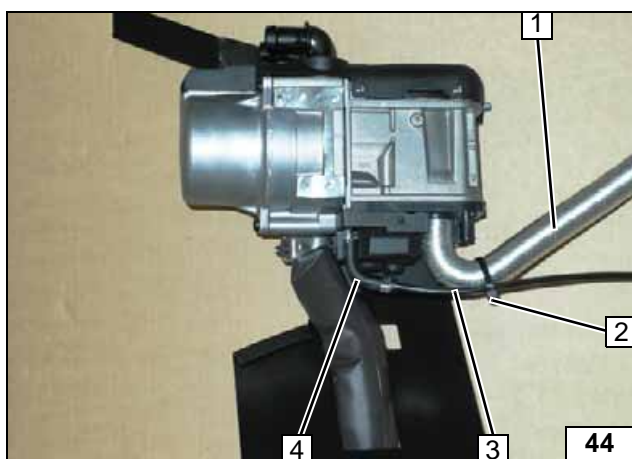

- 1** Combustion air pipe
- 2** Cable tie
- 3** Fuel line
- 4** 90° moulded hose, 10mm dia. clamp [2x]

Premounting heater

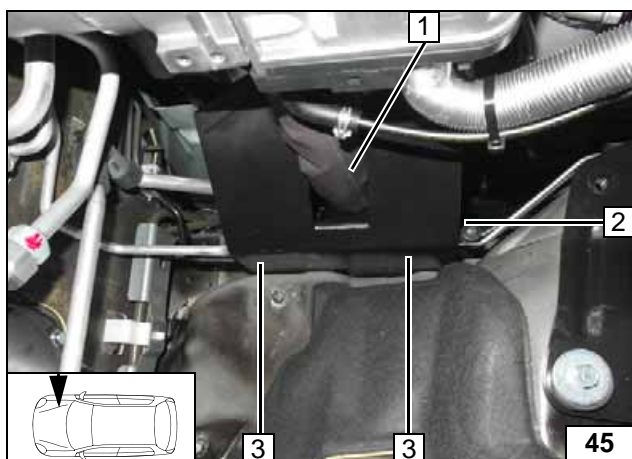

Installing Heater

Install bracket **2** with oblong holes between body and original vehicle line holder and align. Route exhaust pipe **1** between heat shield plate and turbo charger downwards. Tighten M8 bolts [2x] in position **3** (hidden by bracket)!



Installing heater

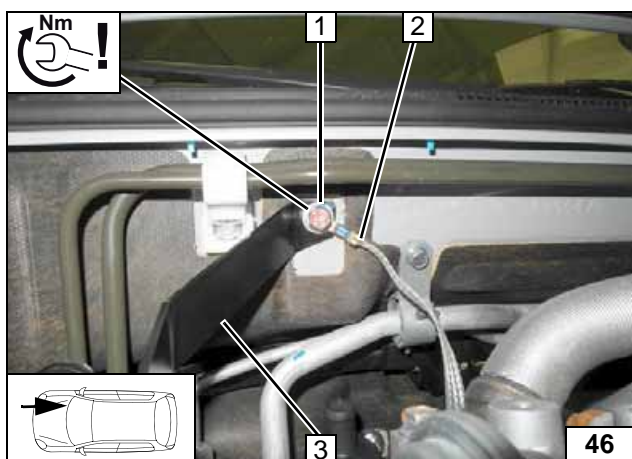

Install heater bracket **3** together with original vehicle earth wire **2** and align. Produce earth connections in position **1**.

- 1** Original vehicle bolt



Installing heater

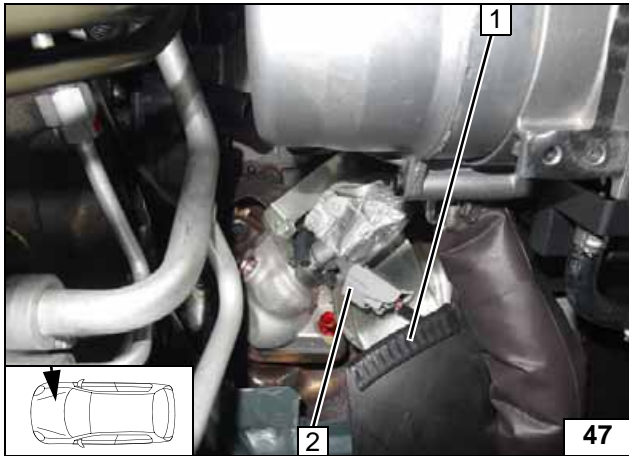
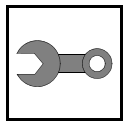

Check the distance between original vehicle connector 2 and bracket 1!

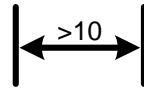

Distance of connector

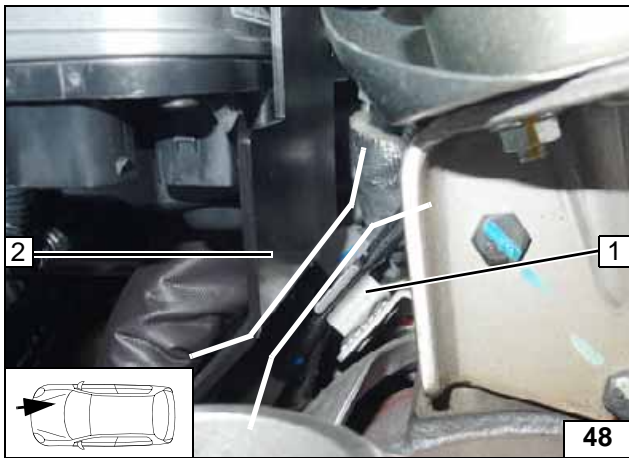

Check the distance between original vehicle cable holder 1 and heater bracket 2!

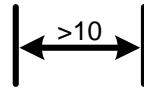

Distance of cable holder

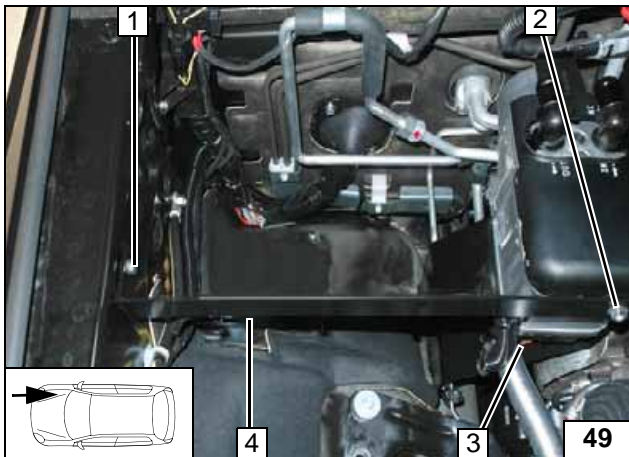

Route wiring harness of heater on strut 4 to the heater!



- 1 M6x20 bolt, spring lockwasher on rivet nut
- 2 M6 flanged nut, M6x12 bolt (premounted)
- 3 Heater wiring harness

Installing strut

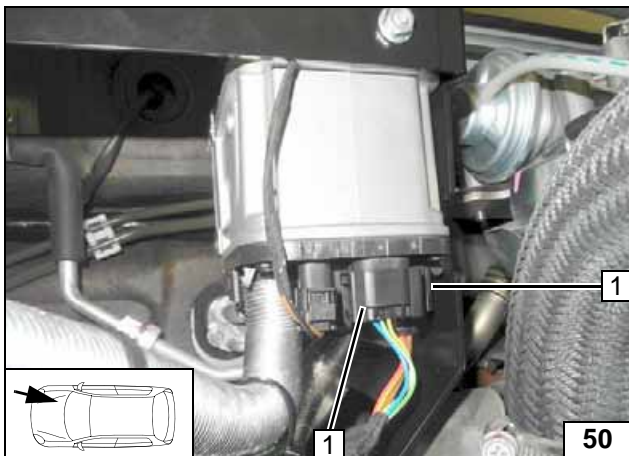

- 1 Heater wiring harness connector [2x]

Installing wiring harness of heater

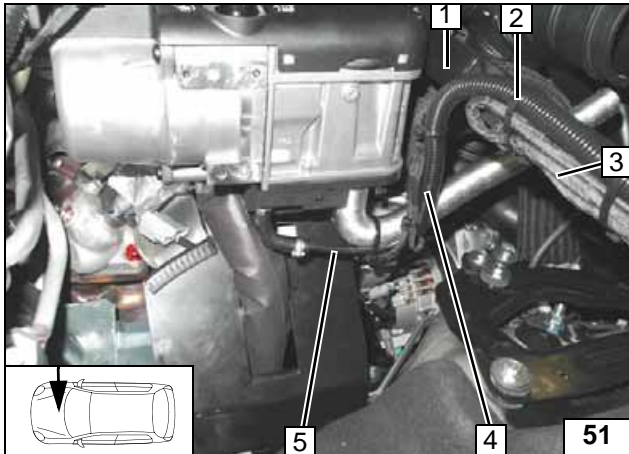
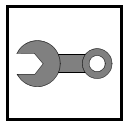

Pull fuel line of heater **5** and wiring harness of metering pump into 10mm dia. corrugated tube **4** and route behind strut **1** to the right side of the vehicle.

- 2** Cable tie
- 3** Heater wiring harness



Routing wiring harnesses

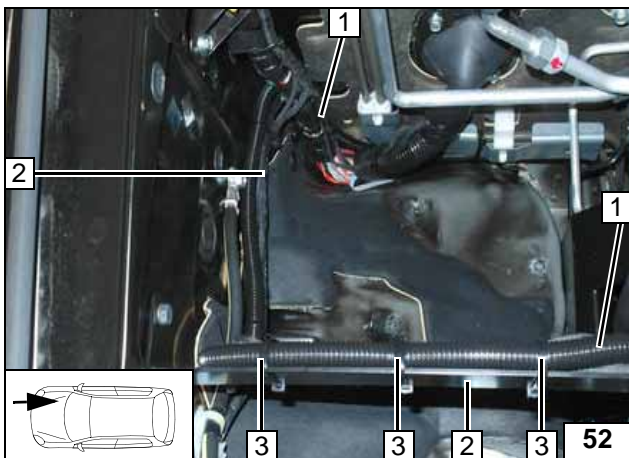

Route fuel line of heater and wiring harness of metering pump in 10mm dia. corrugated tube **1** along original vehicle lines to the underbody.

- 2** Heater wiring harness
- 3** Cable tie [3x]



Routing wiring harnesses

Mitsubishi Pajero



Fuel

CAUTION!

Open the vehicle's fuel tank cap, ventilate the tank and then re-close the tank lock.

Catch any fuel running off in an appropriate container.

Route fuel line and metering pump wiring harness so that they are protected against stone impact. Unless specified otherwise, always fasten using cable ties.

Provide rub protection for fuel line and wiring harness in areas where there are sharp edges.

WARNING!

The fuel line and wiring harness are routed to the metering pump as shown in the wiring harness routing diagram.

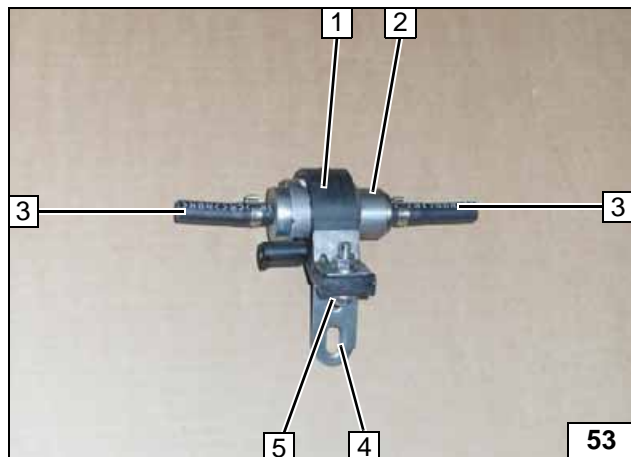

- 1 Metering pump mount
- 2 Metering pump
- 3 Hose section, 10 mm dia. clamp [2x]
- 4 Angle bracket
- 5 M6x25 bolt, support angle bracket, flanged nut

Premounting metering pump

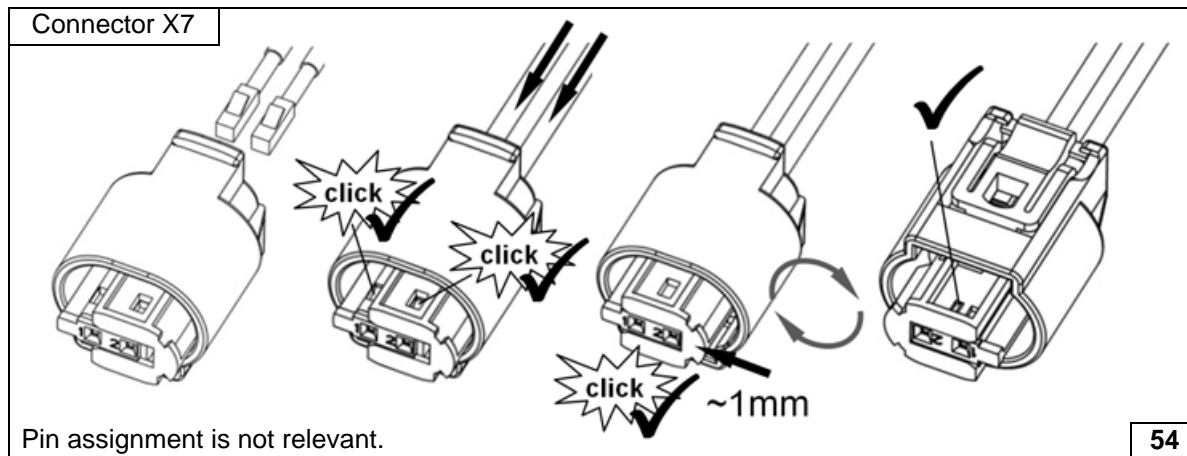

Pin assignment is not relevant.

Completing metering pump connector

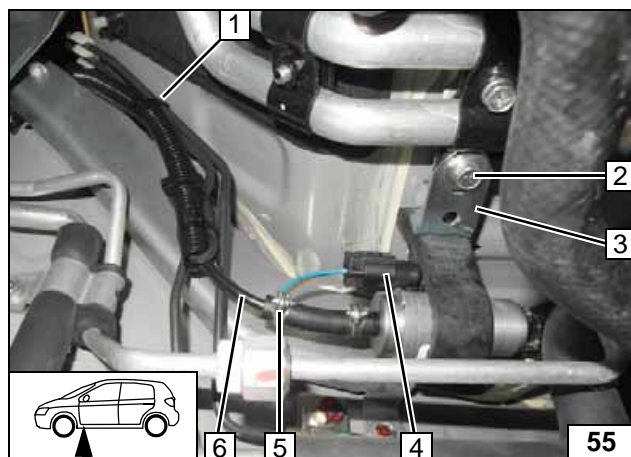

- 1 10mm dia. corrugated tube, cable tie on original vehicle line
- 2 Original vehicle bolt
- 3 Angle bracket
- 4 Metering pump wiring harness, connector X7 mounted
- 5 10 mm dia. clamp
- 6 Fuel line of heater



Installing metering pump

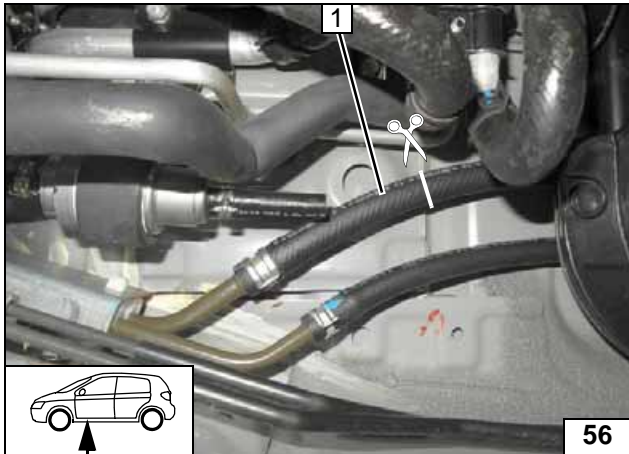
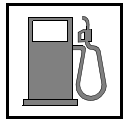

Cut off fuel supply line 1 at the marking.



Fuel extraction

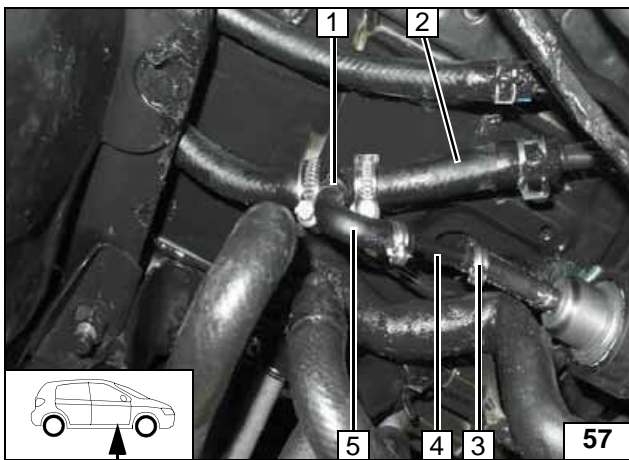

Ensure sufficient distance from adjacent components, correct if necessary.



Inserting fuel standpipe

- 1 10x5x10 fuel standpipe, 16-27mm dia. clamp [2x]
- 2 Fuel supply line
- 3 10 mm dia. clamp
- 4 Fuel line
- 5 90° moulded hose, 10mm dia. clamp [2x]

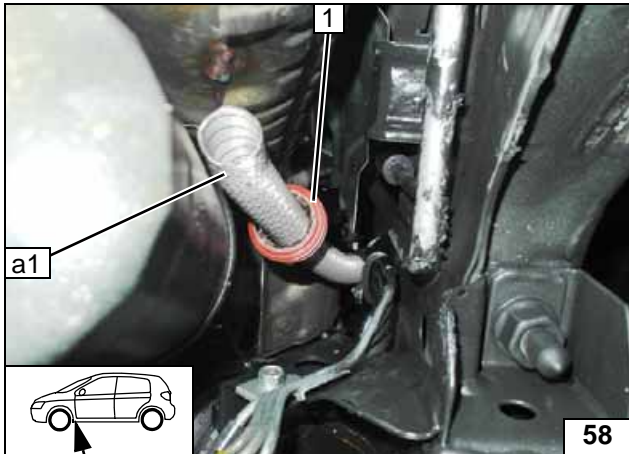
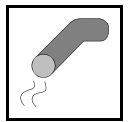

Exhaust Gas

- 1 Spacer bracket



Installing spacer bracket

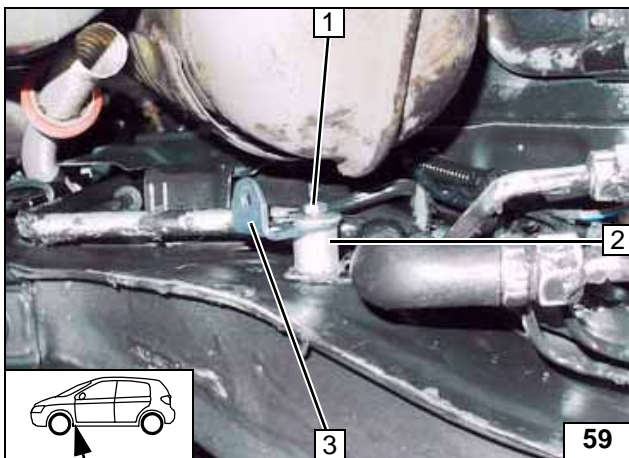

Remove original vehicle bolt in position 1; will be reused.

- 1 M6x35 bolt, spring lockwasher
- 2 20mm shim
- 3 Angle bracket



Installing angle bracket

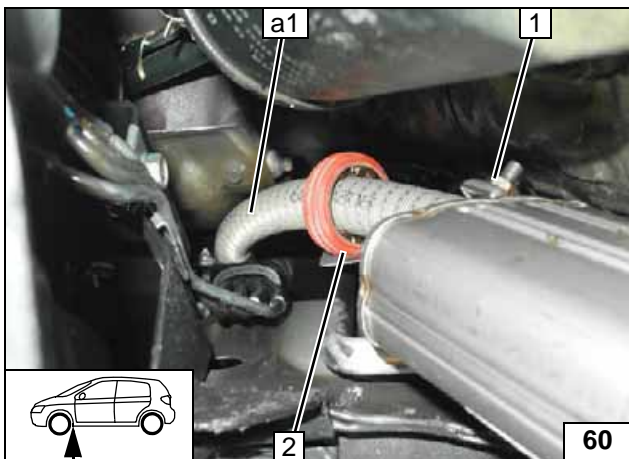

- 1 Hose clamp
- 2 Align spacer bracket with heat shield plate

Installing exhaust pipe a1

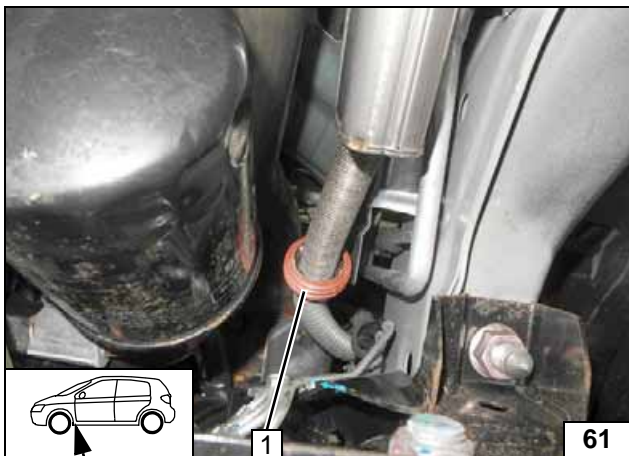

Align spacer bracket 1 with heat shield plate. Ensure sufficient distance from adjacent components, correct if necessary.



Aligning spacer bracket

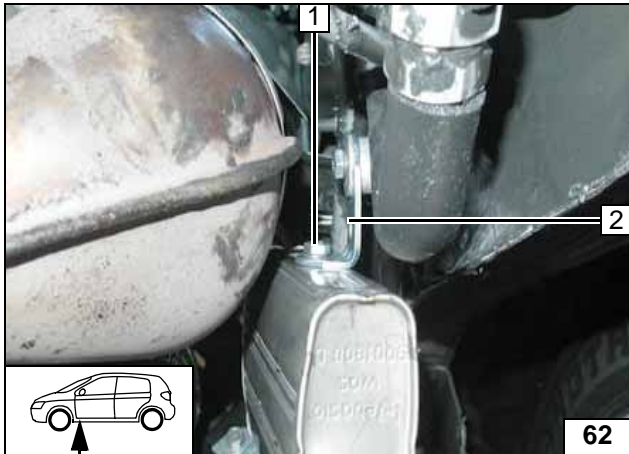
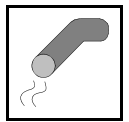

- 1 M6x16 bolt, spring lockwasher
- 2 Angle bracket



Installing exhaust silencer



Align exhaust silencer with original vehicle parts!

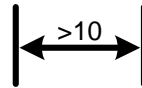

Positioning exhaust silencer

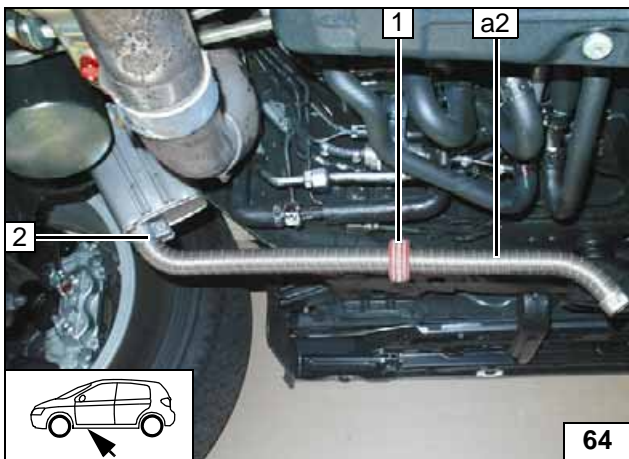

- 1 Slide on spacer bracket
- 2 P-clamp



Installing exhaust pipe a2

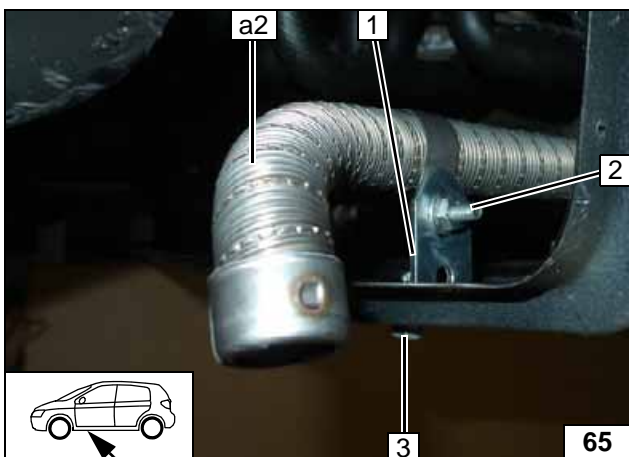

- 1 Angle bracket
- 2 M6x20 bolt, p-clamp, flanged nut on angle bracket
- 3 Original vehicle bolt, original vehicle hole, angle bracket, flanged nut

Fastening exhaust pipe a2

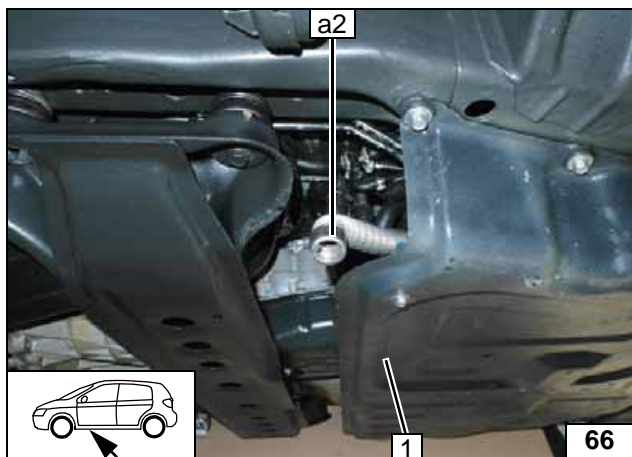
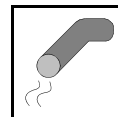

1 Underride protection



Positioning
exhaust pipe
a2



Coolant Circuit



WARNING!

Any coolant running off should be collected in an appropriate container. Route hoses kink-free. Unless specified otherwise, always fasten using cable ties. Position clamps so that other hoses cannot be damaged. The heater must be filled with coolant when installing the hoses.

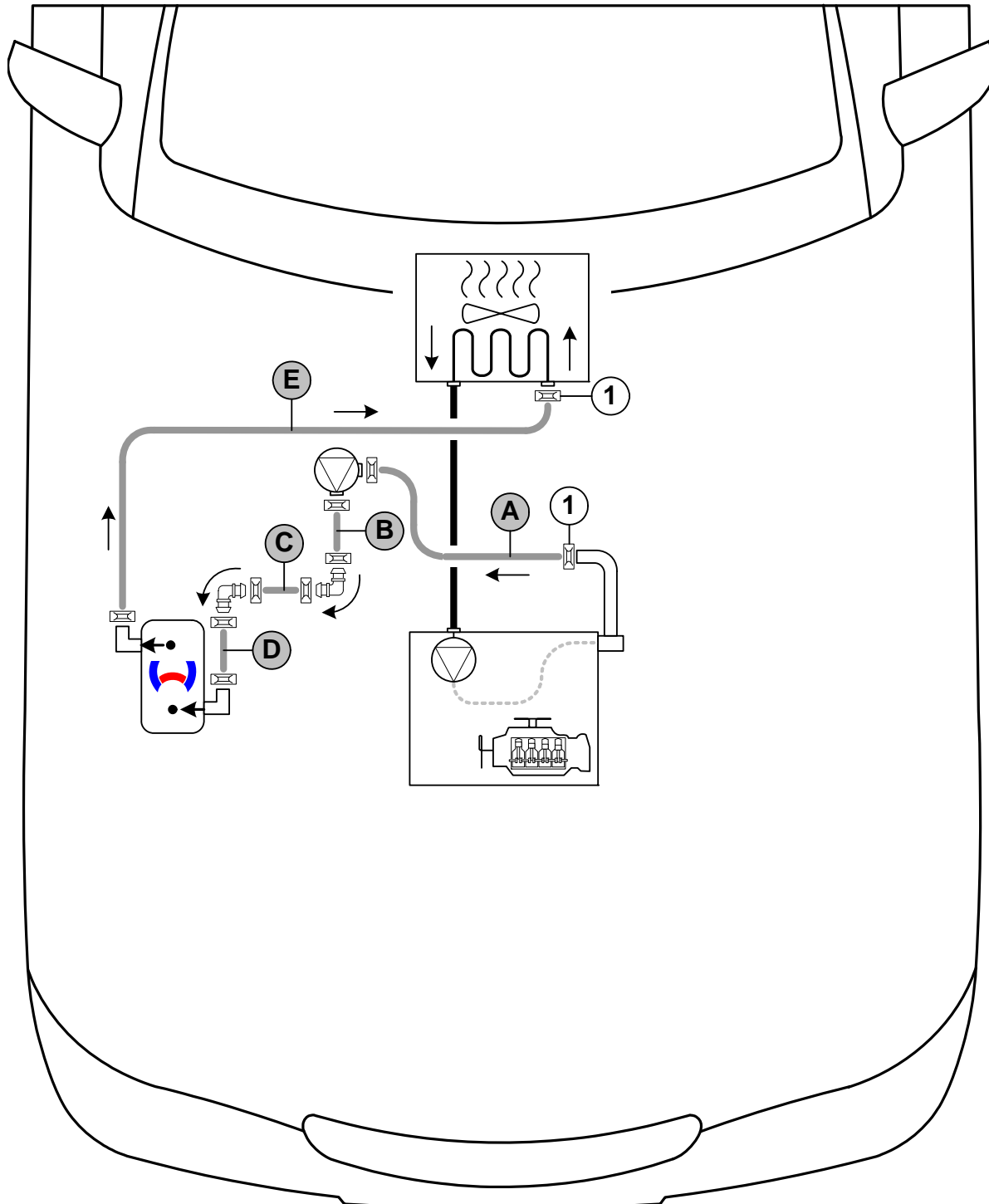
The connection should be modelled on an 'inline' circuit and based on the following diagram:



Hose routing diagram

All spring clips without a specific designation  = 25 mm dia. All connecting pipes  = 18x18mm dia. **1** = Original vehicle spring clip .



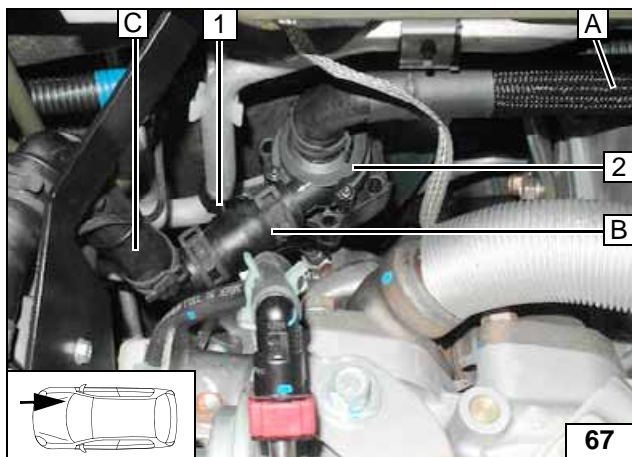

- 1 Spacer bracket between A/C line and water hose **B**
- 2 Circulating pump

Connect-
ing circulat-
ing pump

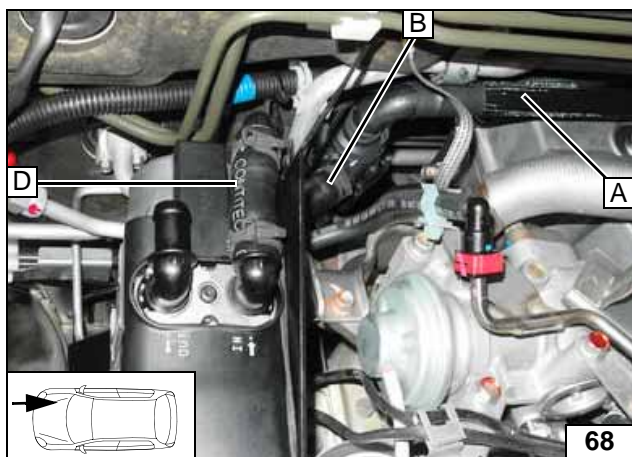

Connect-
ing heater
inlet

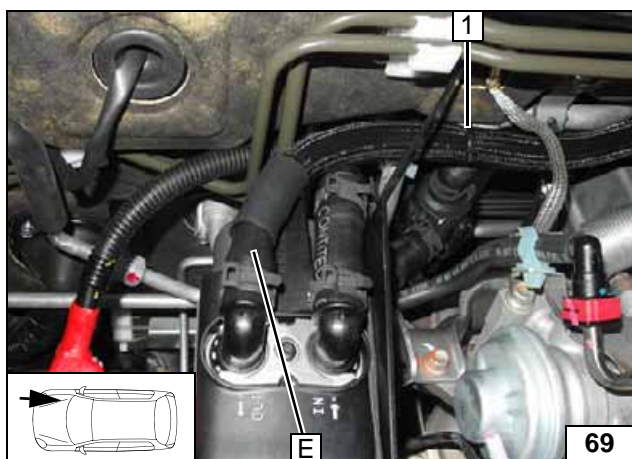

Align hose **E**.

- 1 Cable tie



Connect-
ing heater
outlet

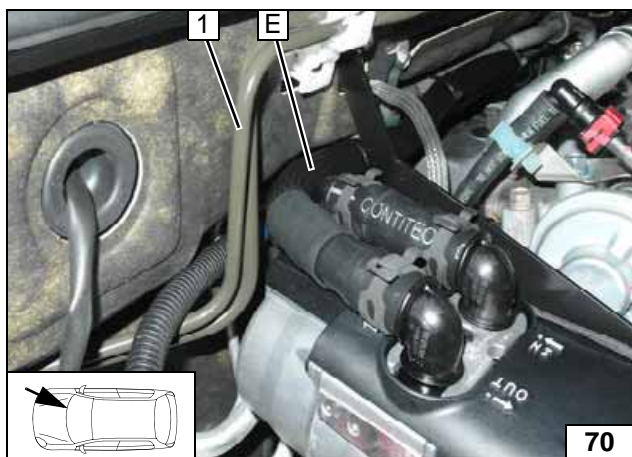

Check the distance between hose **E** and original vehicle fuel line **1**!

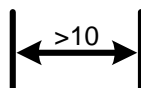

Routing
hose **E**

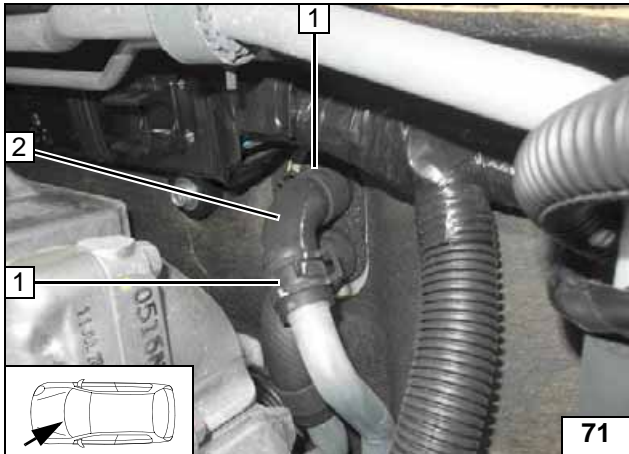

Remove hose of engine outlet / heat exchanger inlet **2** and discard. Spring clips **1** [2x] will be reused!



Cutting point

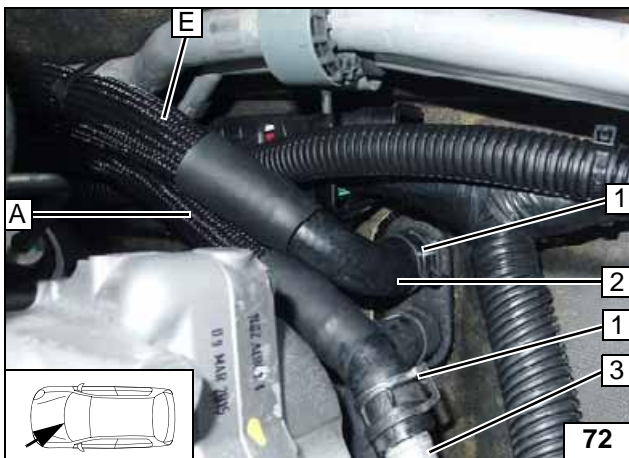

Install hose **E** first and then hose **A**.

- 1 Original vehicle spring clip [2x]
- 2 Heat exchanger inlet
- 3 Pipe of engine outlet



Connecting heat exchanger inlet and engine outlet

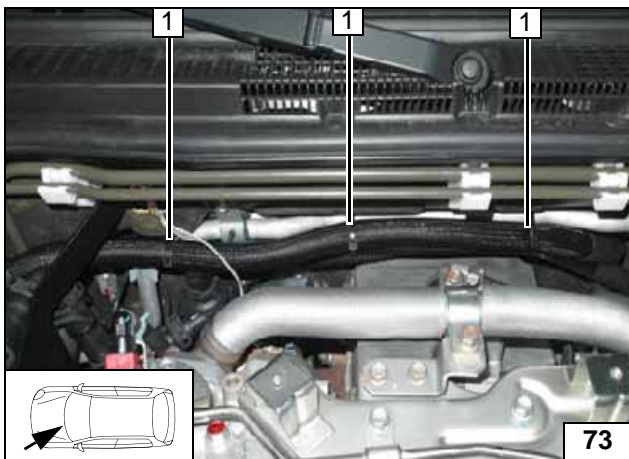

Ensure sufficient distance from engine.

- 1 Cable tie [3x]



Routing in engine compartment



- 1 Wiring harness of circulating pump

Routing of circulating pump wiring harness

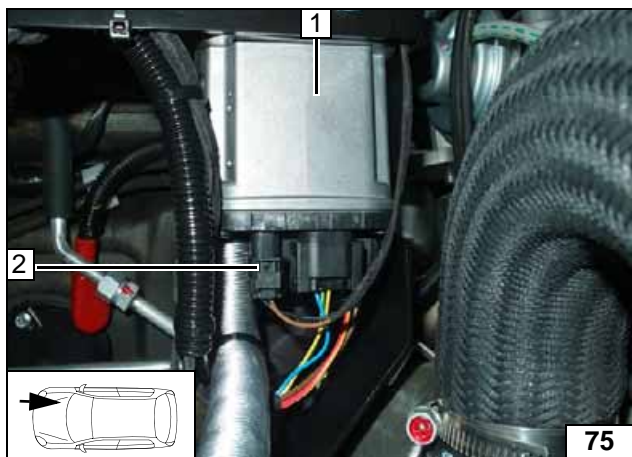

- 1 Heater
- 2 Connector of circulating pump

Installing
connector of circulat-
ing pump

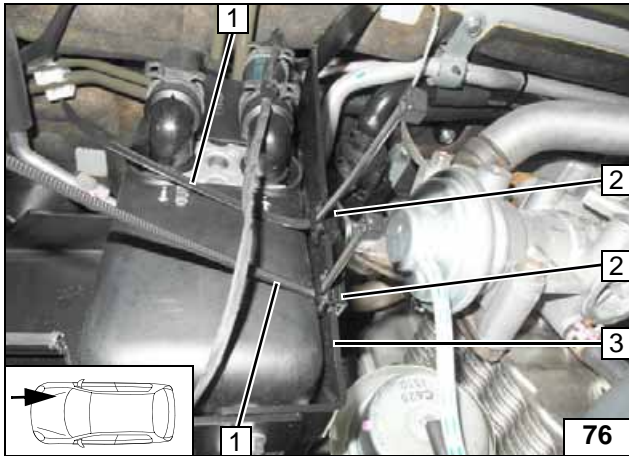
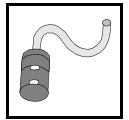

Combustion Air

Replace cable tie with provided cable tie 1 [2x]!

- 2 Retaining clip [2x]
- 3 Heater bracket



Installing retaining clip

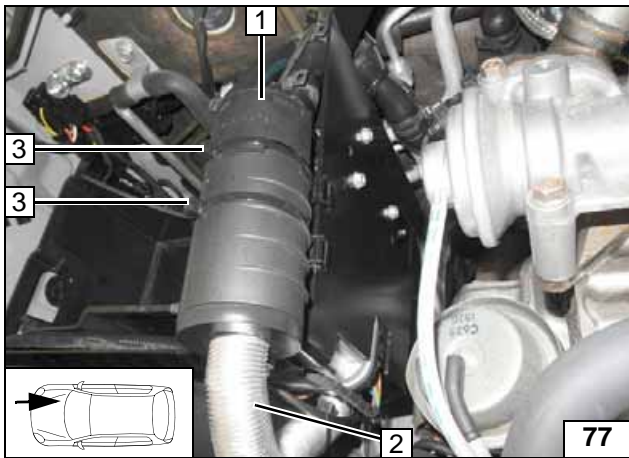

- 1 Silencer
- 2 Combustion air pipe
- 3 Close cable tie [2x]



Installing silencer



Final Work

WARNING!

Reassemble the components in reverse order. Check all hoses, clamps and all electrical connections for firm seating. Insulate and tie back all loose lines.

Only use manufacturer-approved coolant. Spray the heater components with anti-corrosion wax (Tectyl 100K).



- **Connect the battery.**
- **Fill and bleed the coolant circuit according to the vehicle manufacturer's specifications.**
- **Program MultiControl CAR, teach Telestart transmitter**
- **Make settings on the A/C control panel according to the 'Operating Instructions'.**
- **Place the 'Switch off parking heater before refuelling' caution label near the filler neck.**
- **For initial startup and function check, please see installation instructions.**



Operating Instructions for Automatic Air-Conditioning

Please remove page and add to the vehicle operating instructions.

Note:

We recommend matching the heating time to the driving time.

Heating time = driving time

Example:

For a driving time of approx. 20 min. (in one direction), we recommend not exceeding a switch-on time of 20 min.

Passenger compartment monitoring, if installed, must be deactivated in addition to vehicle settings for the heating operation.

For instructions on deactivation, please refer to the operating instructions of the vehicle.

Before parking the vehicle, make the following settings:



- 1 Air outlet onto windscreen (press Defrost button)
- 2 Set fan to level '1', or max. '2'
- 3 Set temperature to '29°C' (max.)

A/C control panel

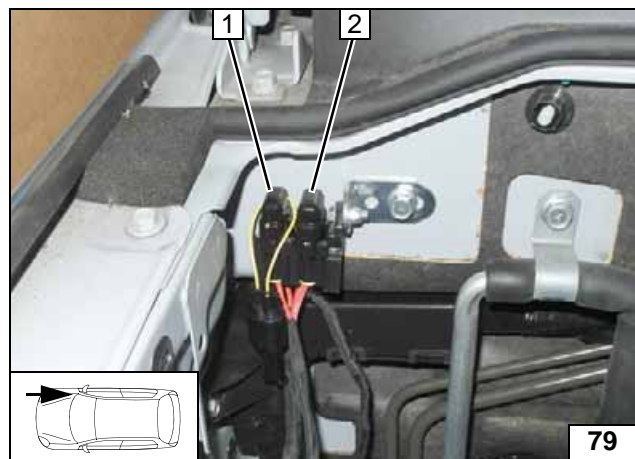

- 1 20A heater fuse F1
- 2 30A main fuse F2 of passenger compartment

Engine compartment fuses

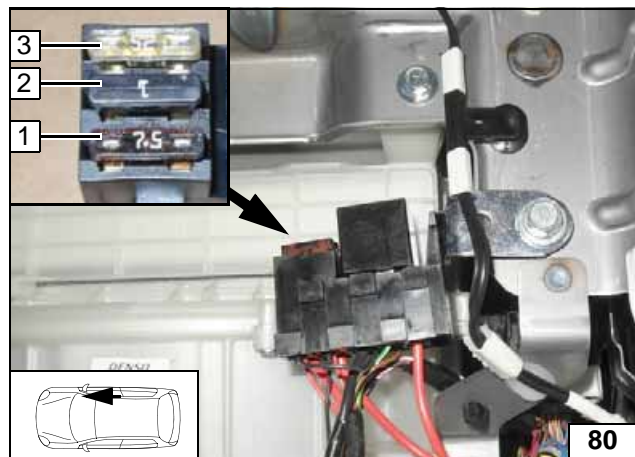

- 1 7.5A fan fuse F5
- 2 1A fuse F3 of heater control
- 3 25A fan fuse F4

Passenger compartment fuses

