



# Water Heater

## Thermo Top Evo Parking Heater



With FuelFix

# Installation Documentation Skoda Fabia / Fabia Estate Car

### Validity

Manufacturer	Model	Type	EG BE No. / ABE
Skoda Fabia	Fabia	NJ	e11 * 2001 / 116 * 0291 * ...

Motorisation	Fuel	Transmission type	Output in kW	Displacement in cm <sup>3</sup>	Engine code
1.0 MPI	Petrol	5-speed SG	55	999	CHYB
1.2 TSI	Petrol	5-speed SG	66	1197	CJZA
1.2 TSI	Petrol	6-speed SG	81	1197	CJZD
1.4 TDI	Diesel	5-speed SG	66	1422	CUSB

SG = manual transmission

from model year 2015

Left-hand drive vehicle

**Verified equipment variants:** Manual / automatic air-conditioning system  
Start / Stop  
Green tec  
Euro 6  
Front fog lights

**Not verified:** Passenger compartment monitoring  
Headlight washer system

**Total installation time:** approx. 8.5 hours

## Table of Contents

Validity	1	Preparing Installation Location	19
Necessary Components	2	Preparing Heater	21
Installation Overview	2	Installing Heater	22
Information on Total Installation Time	2	Exhaust Part 1	25
Information on Operating and Installation Instructions	3	Coolant Circuit for Petrol Vehicles	26
Information on Validity	4	Coolant Circuit for Diesel Vehicles	33
Technical Information	4	Combustion Air	39
Explanatory Notes on Document	4	Fuel	40
Preliminary Work	5	Installing FuelFix for Petrol Vehicles	43
Heater Installation Location	5	Installing FuelFix for Diesel Vehicles	48
Preparing Electrical System	6	Exhaust Part 2	52
Electrical System	11	Final Work	57
Manual Air-Conditioning Fan Controller	12	FuelFix Template for Petrol Vehicles	58
Fan Controller for Automatic Air-Conditioning	14	FuelFix Template for Diesel Vehicles	59
MultiControl CAR Option	17	Operating Instructions for Manual Air-Conditioning	60
Remote Option (Telestart)	17	Operating Instructions for Automatic Air-Conditioning	61
ThermoCall Option	18		

## Necessary Components

- Basic delivery scope of Thermo Top Evo in accordance with price list
- Installation kit with FuelFix for Skoda Fabia / Fabia Estate Car 2015 Petrol and diesel: **1323759B**
- Additionally required in case of automatic air-conditioning: Additional kit AAC for Skoda Fabia 2015 **1323164\_**
- Heater control in accordance with price list and upon consultation with end customer
- In case of Telestart, indicator lamp in accordance with price list and in consultation with end customer

## Installation instructions:

- Arrange for the vehicle to be delivered with the tank only about ¼ full.
- The installation location of the push button in case of Telestart or ThermoCall should be confirmed with the end customer.
- Depending on the space required and the vehicle manufacturer's instructions, we recommend the use of a vehicle battery with a higher electrical capacity.

## Installation Overview

### Legend:

1. Heater
2. Engine compartment fuse holder
3. Passenger compartment relay and fuse holder
4. PWM GW (only in case of automatic air-conditioning)
5. Circulating pump
6. MultiControl CAR
7. Metering pump
8. FuelFix

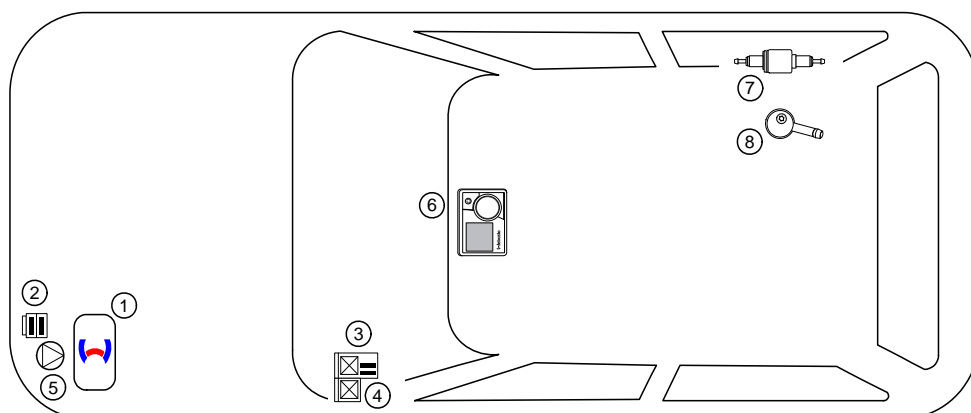

## Information on Total Installation Time

The total installation time includes the time needed for mounting and demounting the vehicle-specific components, the heater specific installation time and all other times required for the system integration and initial start-up of the heater. The total installation time may vary for vehicle equipment other than provided.

## Information on Operating and Installation Instructions

### 1 Important information (not complete)

#### 1.1 Installation and repair



The improper installation or repair of Webasto heating and cooling systems can cause fire or the leakage of deadly carbon monoxide, leading to serious injury or death.



To install and repair Webasto heating and cooling systems you need to have completed a special company training course and have the appropriate technical documentation, special tools and special equipment.



Installation and repair may ONLY be carried out by persons trained and certified in a Webasto training course. NEVER try to install or repair Webasto heating or cooling systems if you have not completed a Webasto training course, you do not have the necessary technical skills and you do not have the technical documentation, tools and equipment available to ensure that you can complete the installation and repair work properly.

Only use genuine Webasto parts. See the Webasto air and water heaters accessories catalogue for this purpose.

#### 1.2 Operation

To ensure safe operation, we recommend having the heater checked every two years by an authorised Webasto dealer, especially when used over a long period and/or under extreme environmental conditions.

Do not operate the heater in closed rooms due to the danger of poisoning and suffocation.

Always switch off the heater before refuelling.

The heater may only be used with the prescribed fuel diesel (DIN EN 590) or petrol (DIN EN 228).

The heater may not be cleaned with a high-pressure cleaner.

#### 1.3 Please note

ALWAYS follow all Webasto installation and operating instructions and observe all warnings.

To become familiar with and understand all functions and properties of the heater, the operating instructions must be read carefully and observed at all times.

For proper, safe installation and repair work, the installation instructions with all warnings and safety information must be carefully read and observed at all times. Please always contact a workshop authorised by Webasto for all installation and repair work.

#### Important

**Webasto shall assume no liability for defects, damage and injuries resulting from a failure to observe the installation, repair and operating instructions of the information contained in them.**

**This liability exclusion particularly applies to improper installations and repairs, installations and repairs by untrained persons or in the case of a failure to use genuine spare parts.**

**The liability due to culpable disregard to life, limb or health and due to damage or injuries caused by a wilful or reckless breach of duty remain unaffected, as does the obligatory product liability.**

Installation should be carried out according to the general, standard rules of technology. Unless specified otherwise, fasten hoses, lines and wiring harnesses to original vehicle lines and wiring harnesses using cable ties. Insulate loose wire ends and tie back. Connectors on electronic components have to audibly click into place during installation.

Sharp edges should be fitted with rub protection. Spray unfinished body areas, e.g. drilled holes, with anti-corrosion wax (Tectyl 100K).

Observe the instructions and guidelines of the respective vehicle manufacturer for demounting and mounting vehicle specific components!

The initial startup is to be executed with the Webasto Thermo Test Diagnosis.

When installing a programmable control module (e.g. a PWM Gateway), the corresponding settings must be checked or adjusted.

### 2 Statutory regulations governing installation

Guidelines	Thermo Top Evo
Heating Directive ECE R122	E1 00 0258
EMC Directive ECE R10	E1 04 5627

#### Note

The regulations of these guidelines are binding in the scope of the Directive 70/156/EEC and/or 2007/46/EC (for new vehicle models from 29/04/2009) and should also be observed in countries in which there are no special regulations.

#### Important

Failure to follow the installation instructions will result in the invalidation of the type approval for the heater and therefore invalidation of the general **homologation of the vehicle**.

#### Note

The heater is licensed in accordance with paragraph 19, section 3, No. 2b of the StVZO (German Road Traffic Licensing Authority).

### 2.1 Excerpt from ECE regulation 122 (heating system) paragraph 5 for the installation of the heater

Beginning of excerpt.

#### ANNEX VII

#### REQUIREMENTS FOR COMBUSTION HEATERS AND THEIR INSTALLATION

##### 1. GENERAL REQUIREMENTS

1.7.1. A clearly visible tell-tale in the operator's field of view shall inform when the combustion heater is switched on or off.

##### 2. VEHICLE INSTALLATION REQUIREMENTS

###### 2.1. Scope

2.1.1. Subject to paragraph 2.1.2, combustion heaters shall be installed according to the requirements of this Annex.

2.1.2. Vehicles of category O having liquid fuel heaters are deemed to comply with the requirements of this Annex.

###### 2.2. Positioning of heater

2.2.1. Body sections and any other components in the vicinity of the heater must be protected from excessive heat and the possibility of fuel or oil contamination.

2.2.2. The combustion heater shall not constitute a risk of fire, even in the case of overheating. This requirement shall be deemed to be fulfilled if the installation ensures an adequate distance to all parts and suitable ventilation, by the use of fire resistant materials or by the use of heat shields.

2.2.3. In the case of M2 and M3 vehicles, the heater must not be positioned in the passenger compartment. However, an installation in an effectively sealed envelope which also complies with the conditions in paragraph 2.2.2 may be used.

2.2.4. The label referred to in paragraph 1.4 or a duplicate, must be positioned so that it can be easily read when the heater is installed in the vehicle.

2.2.5. Every reasonable precaution should be taken in positioning the heater to minimise the risk of injury and damage to personal property.

###### 2.3. Fuel supply

2.3.1. The fuel filler must not be situated in the passenger compartment and must be provided with an effective cap to prevent fuel spillage.

2.3.2. In the case of liquid fuel heaters, where a supply separate to that of the vehicle is provided, the type of fuel and its filler point must be clearly labelled.

2.3.3. A notice, indicating that the heater must be shut down before refuelling, must be affixed to the fuelling point. In addition a suitable instruction must be included in the manufacturer's operating manual.

###### 2.4. Exhaust system

2.4.1. The exhaust outlet must be located so as to prevent emissions from entering the vehicle through ventilators, heated air inlets or opening windows.

###### 2.5. Combustion air inlet

2.5.1. The air for the combustion chamber of the heater must not be drawn from the passenger compartment of the vehicle.

2.5.2. The air inlet must be so positioned or guarded that blocking by rubbish or luggage is unlikely.

###### 2.6. Heating air inlet

2.6.1. The heating air supply may be fresh or recirculated air and must be drawn from a clean area not likely to be contaminated by exhaust fumes emitted either by the propulsion engine, the combustion heater or any other vehicle source.

2.6.2. The inlet duct must be protected by mesh or other suitable means.

###### 2.7. Heating air outlet

2.7.1. Any ducting used to route the hot air through the vehicle must be so positioned or protected that no injury or damage could be caused if it were to be touched.

2.7.2. The air outlet must be so positioned or guarded that blocking by rubbish or luggage is unlikely.

End of excerpt.

In multilingual versions the German language is binding.

## Information on Validity

This installation documentation applies to Skoda Fabia / Fabia Estate Car Petrol and diesel vehicles - for validity see page 1 - from model year 2015 and later, assuming technical modifications to the vehicle do not affect installation, any liability claims excluded. Depending on the vehicle version and equipment, modifications may be necessary during installation with respect to this 'installation documentation'.

Vehicle and engine types, equipment variants and other specifications not listed in this installation documentation have not been tested. However, installation according to this installation documentation may be possible.

## Technical Information

### Special Tools

- Hose clamp pliers for auto-tightening hose clamps
- Hose clamp pliers for Clic hose clamps of type W
- Automatic wire stripper, 0.2 - 6mm<sup>2</sup>
- Crimping pliers for cable lug / tab connector, 0.5 - 6mm<sup>2</sup>
- Torque wrench for 2.0 - 10 Nm
- Hose clamping pliers
- Metric thread-setter kit
- Deep-hole marker
- Webasto Thermo Test Diagnosis with current software

### Dimensions

- All dimensions are in mm.

### Tightening torque values

- Tightening torque values of 5x13 heater bolts and 5x11 heater stud bolts = 8Nm.
- Tightening torque value of 5x15 water connection piece retaining plate bolt = 7Nm.
- Tighten other bolt connections in accordance with manufacturer's instructions or in accordance with state-of-the-art technology.

## Explanatory Notes on Document

You will find an identification mark on the outside top right corner of the page in question to provide you with a quick overview of the individual working steps.

Special features are highlighted using the following symbols:

**Mechanical System**



**Electrical System**



**Coolant Circuit**



**Combustion Air**



**Fuel**



**Exhaust Gas**



**Software**



**Specific risk of damage to components.**



**Specific risk due to electrical voltage.**



**Specific risk of injury or fatal accidents.**



**Specific risk of fire or explosion.**



**Reference to the manufacturer's vehicle-specific documents or to the general installation instructions of Webasto components.**



**Reference to a special technical feature.**



**The arrow in the vehicle icon indicates the position on the vehicle and the viewing angle.**



**Tightening torque according to the manufacturer's vehicle-specific documents.**



## Preliminary Work

### Vehicle



- Open the fuel tank cap.
- Ventilate the fuel tank.
- Close the fuel tank cap again.
- Depressurise the cooling system.
- Disconnect and completely remove the battery together with the carrier.
- Remove the windscreen wipers.
- Remove the coolant reservoir cap.
- Remove the coolant reservoir partition wall.
- Remove the windscreen wiper motor.
- Remove the air filter and the intake hose (only in case of 1.2 TSI).
- Remove the left front wheel.
- Remove the left front wheel-well inner panel.
- Remove the horns (there can be one or two) with the bracket.
- Remove the lateral instrument panel trim on the left and right.
- Completely remove the glove box.
- Remove the underride protection.
- Remove the right vehicle underbody trim.
- Fold up the seating surface of the rear bench seat.
- Open the tank-fitting service lid.



### Heater

- Remove years that do not apply from the type and duplicate label.
- Attach the duplicate label (type label) visibly in the appropriate place in the engine compartment.



### Heater Installation Location

- 1 Heater

Installation location

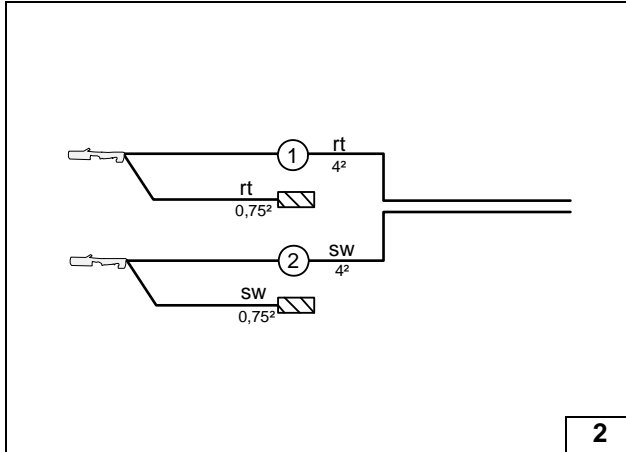
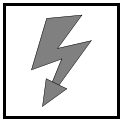

2

### Preparing Electrical System

Wire sections retain their numbering in the entire document.

#### Manual air conditioning

- ① Red (rt) wire of fan wiring harness
- ② Black (sw) wire of fan wiring harness



#### Assigning wires

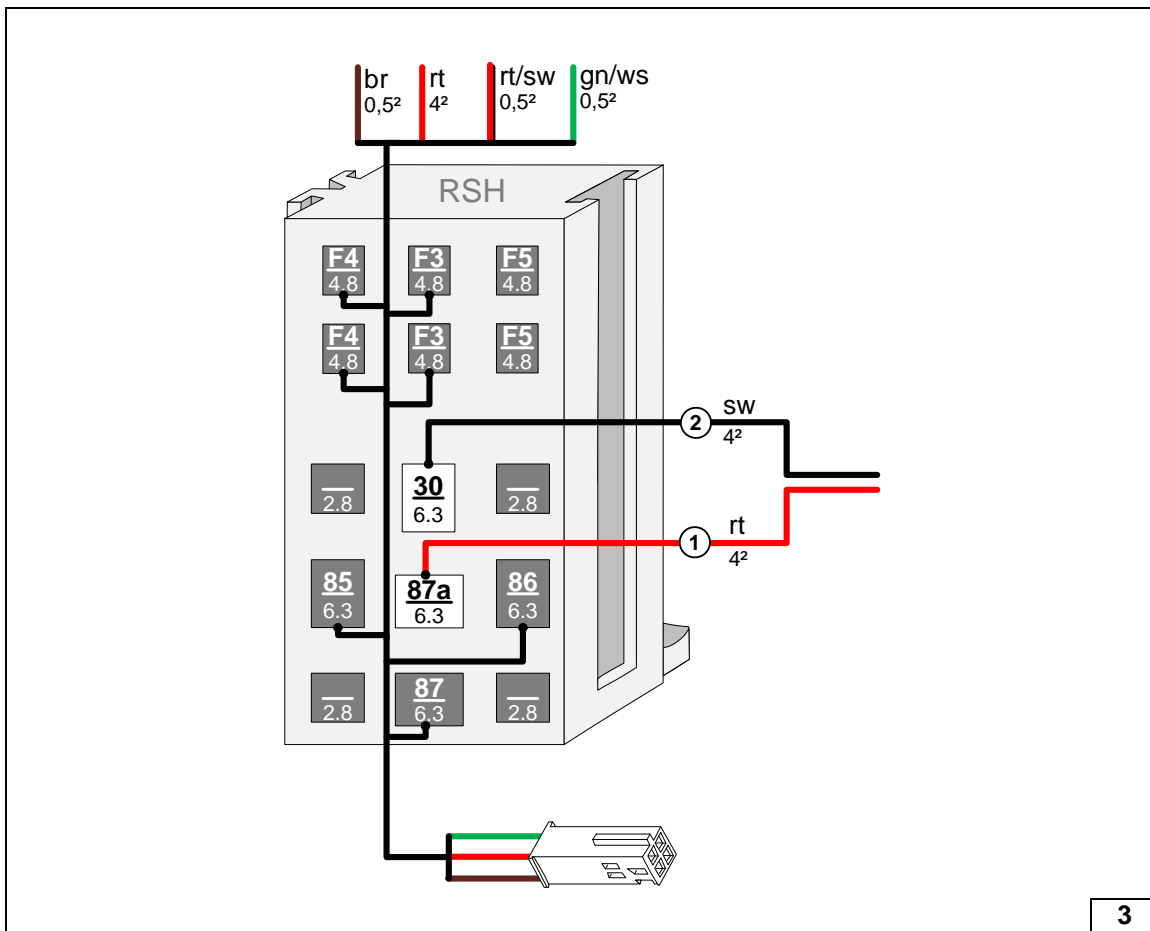

3

#### Preparing passenger compartment relay and fuse holder

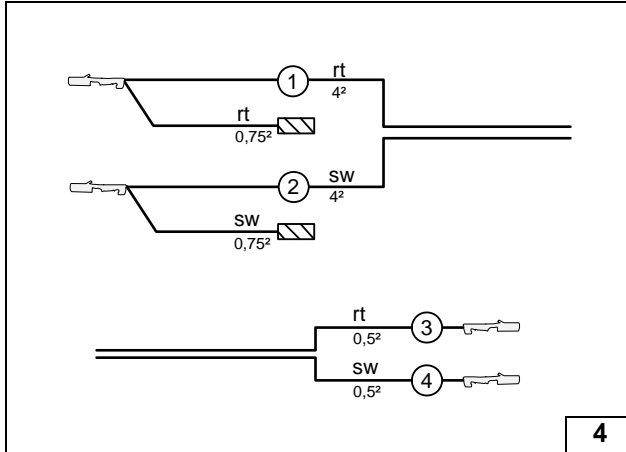

**Automatic air-conditioning**

- ① Red (rt) wire of fan wiring harness
- ② Black (sw) wire of fan wiring harness
- ③ Red (rt) wire of PWM control wiring harness
- ④ Black (sw) wire of PWM control wiring harness



**Assigning wires**

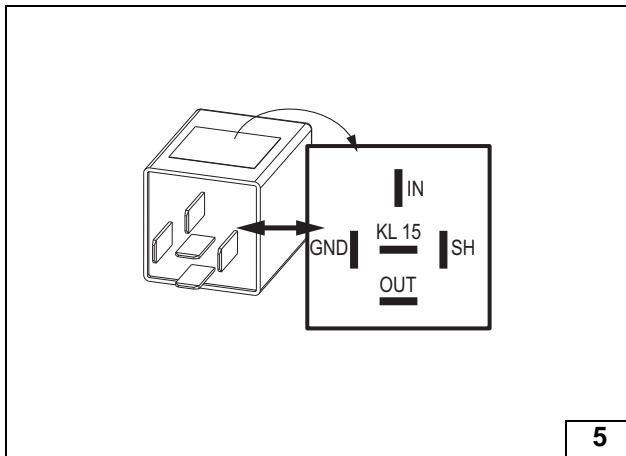

Check the PWM Gateway settings when starting up the heater and adjust if necessary.

Settings:

- Duty cycle: 100% (DC)
- Frequency: not relevant
- Voltage: 3.3V
- Function: High side



**View of PWM GW**

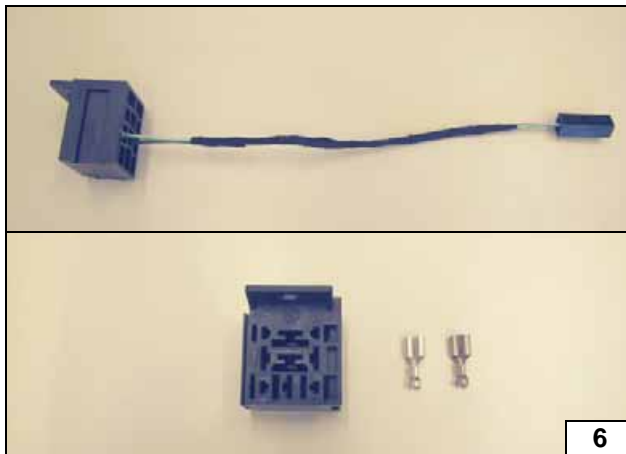

**View of PWM GW socket**

← **Version 1**  
(wiring harness incl. PWM GW socket in kit)

← **Version 2**  
(PWM GW socket loose in kit)



**View of PWM GW socket versions**



Version 1

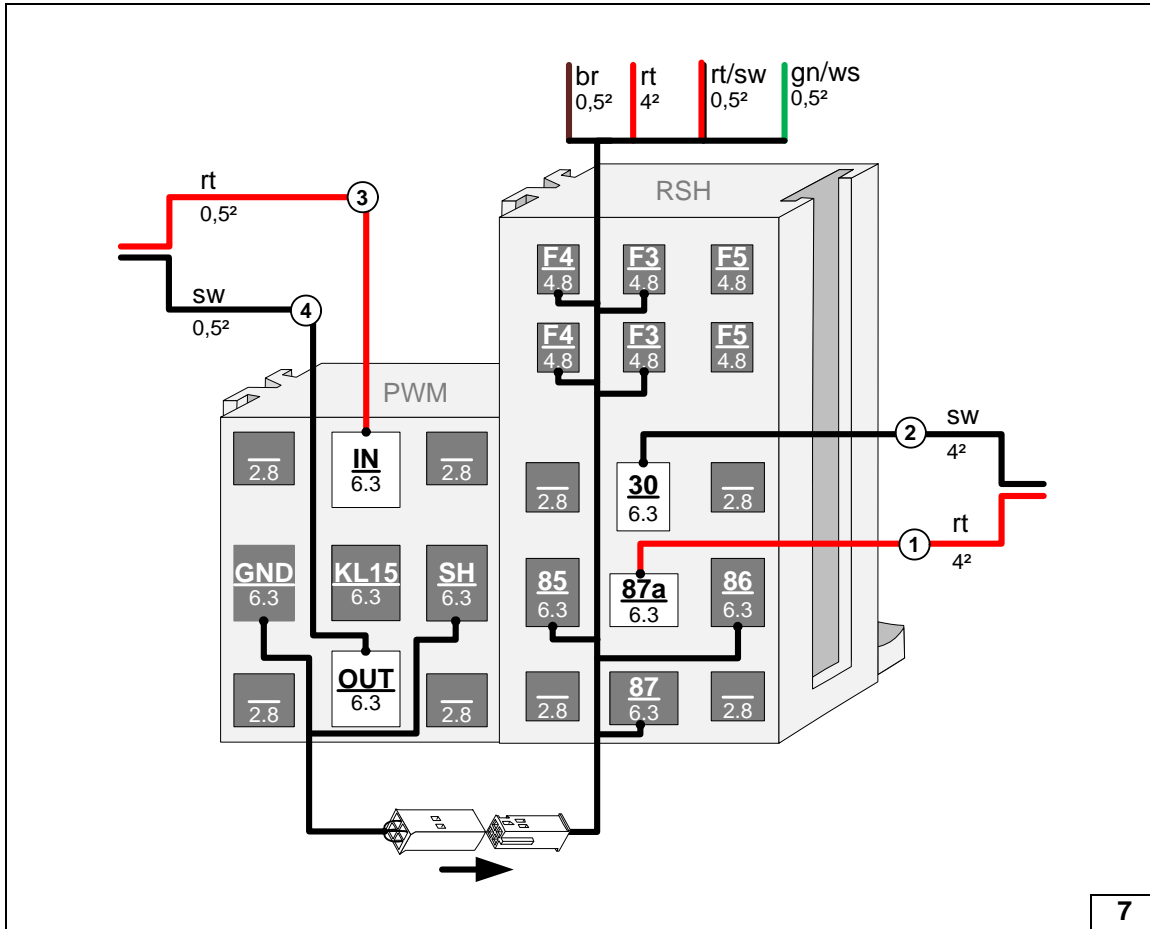

Interlocking PWM GW and passenger compartment relay and fuse holder sockets, inserting connector into bushing, connecting wires

7





Version 2

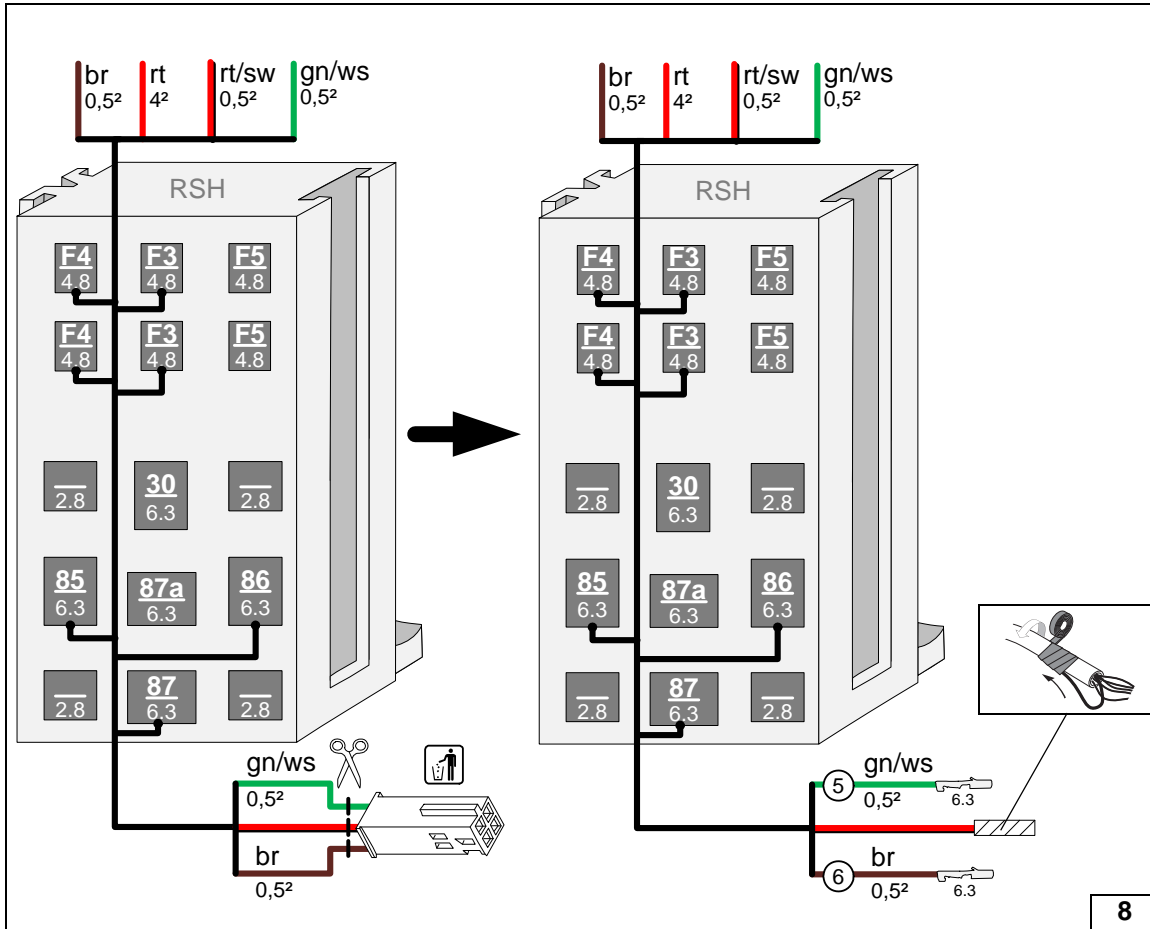

Preparing passenger compartment relay and fuse holder/ installing blade receptacles/ assigning/ insulating wires

8

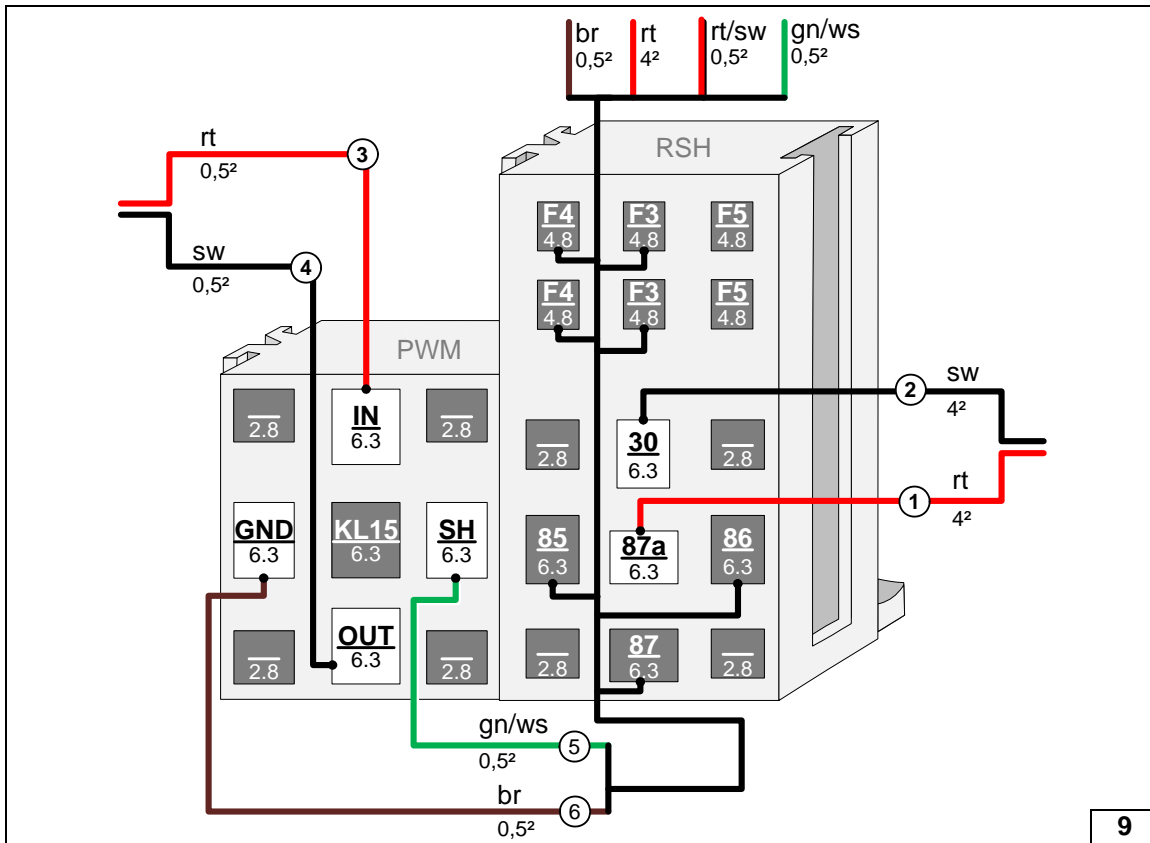

Interlocking sockets of PWM GW and passenger compartment relay and fuse holder, connecting wires

9

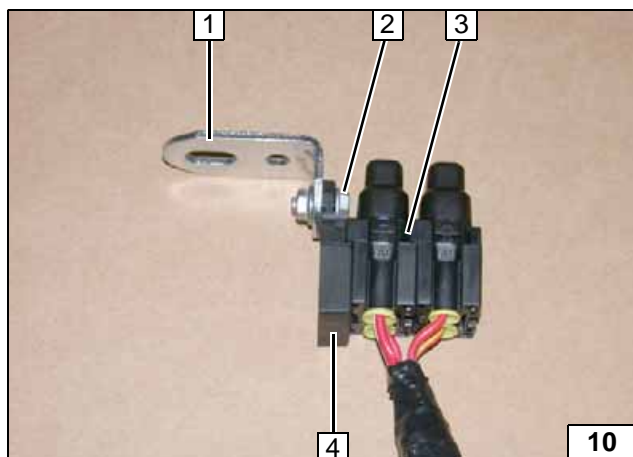
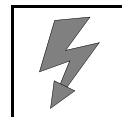

**All versions**

- 1 Angle bracket
- 2 M5x16 bolt, large diameter washer [2x], nut
- 3 Fuses F1-2
- 4 Fuse holder retaining plate

**Preparing fuse holder of engine compartment**



Electrical System



Engine compartment fuse holder

- 1 Clip-type cable tie
- 2 Angle bracket
- 3 M6x20 bolt, large diameter washer, original vehicle hole, flanged nut

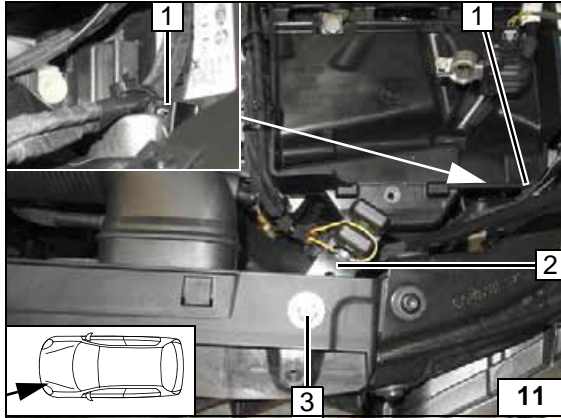

Passenger compartment wiring harness pass through

- 1 Pass through rubber plug of coolant reservoir
- 2 Wiring harnesses of heater, heater control

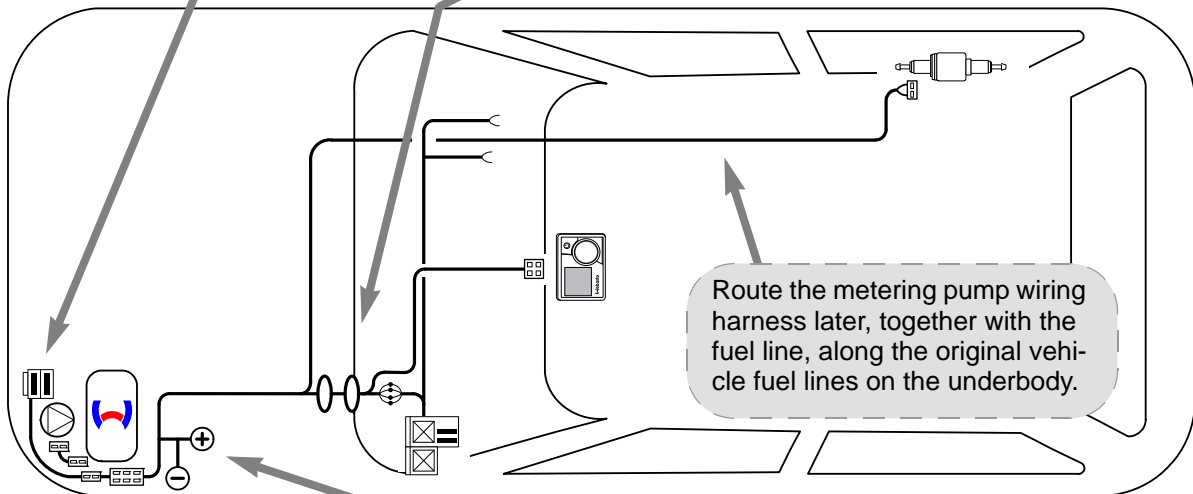
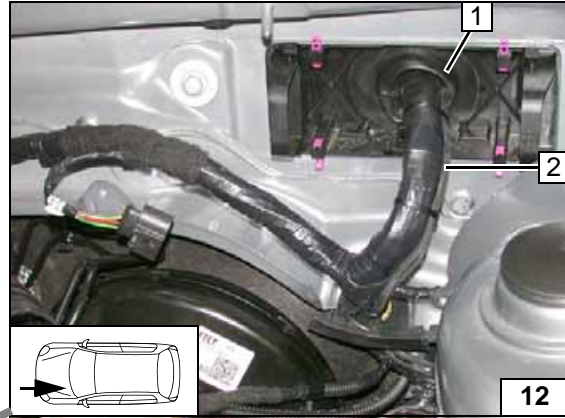

Wiring harness routing diagram

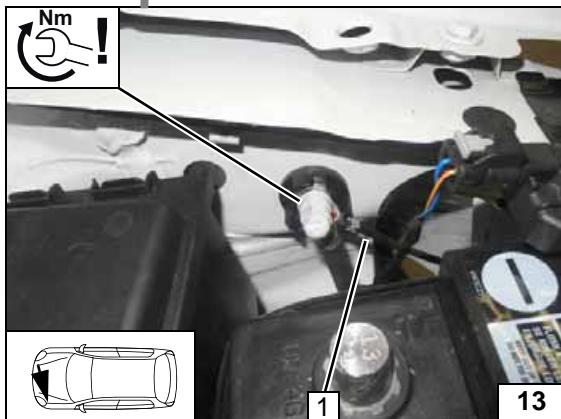

Earth wire

- 1 Earth wire on original vehicle earth support point

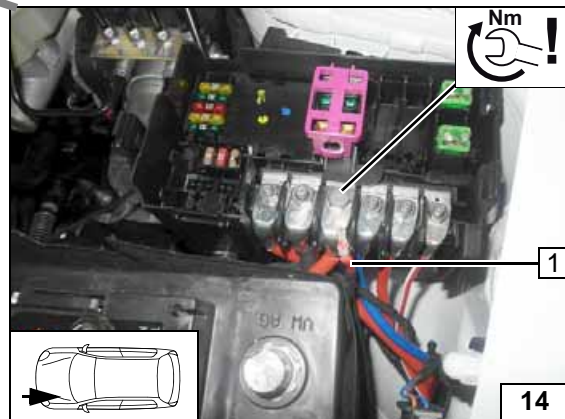

Positive wire

- 1 Positive wire on positive distributor



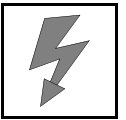

Manual Air-Conditioning Fan Controller

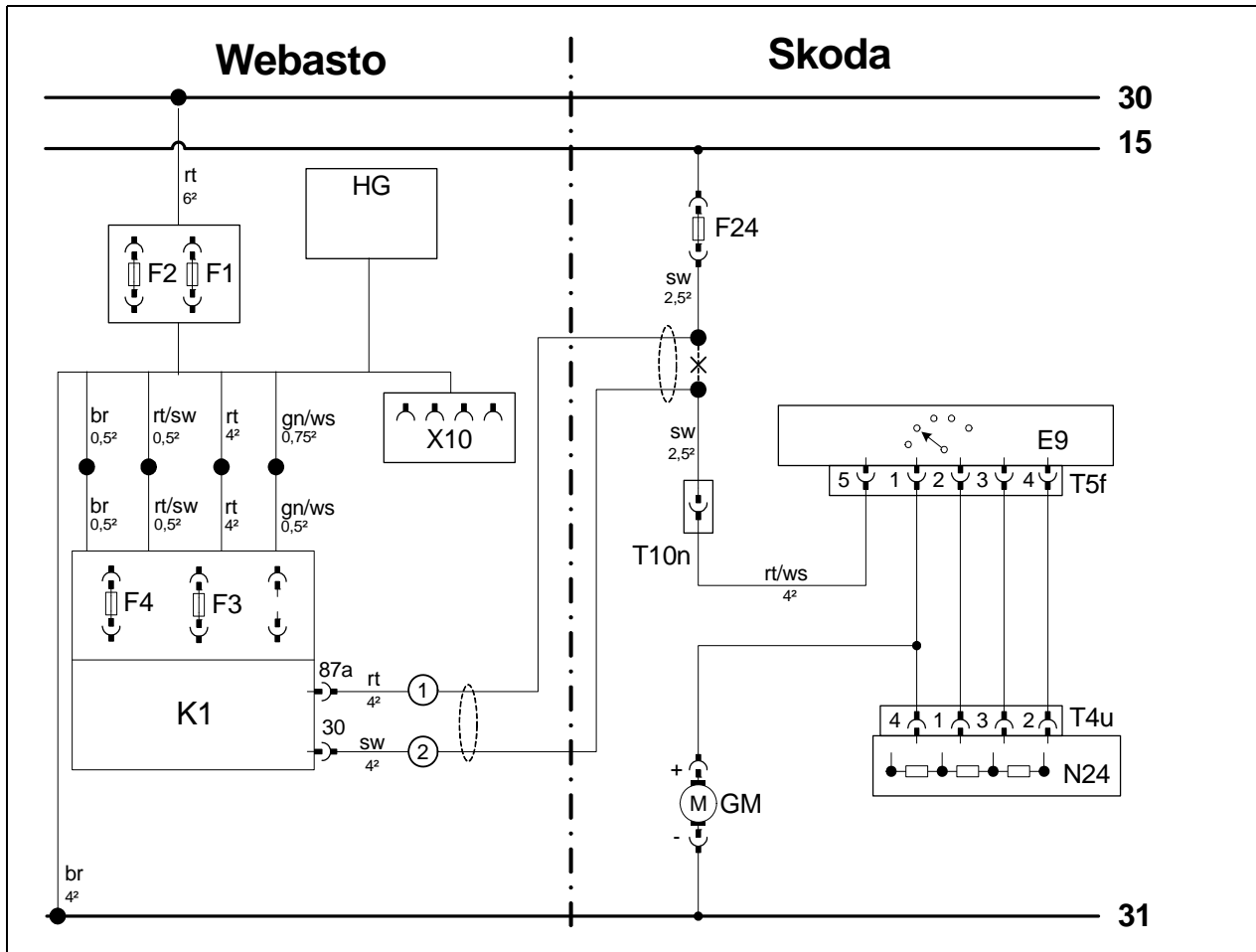

System wiring diagram

Webasto components		Vehicle components		Colours and symbols	
HG	TT-Evo heater	F24	30A fuse	rt	red
F1	20A fuse	E9	Switch unit	ws	white
F2	30A fuse	T5f	5-pin connector E9	sw	black
X10	4-pin connector of heater control	T10n	10-pin connector	br	brown
F3	1A fuse	N24	Resistor group	gn	green
F4	25A fuse	T4u	4-pin connector N24		
K1	Fan relay	GM	Fan motor		
				X	Cutting point
					Wiring colours may vary.

Legend

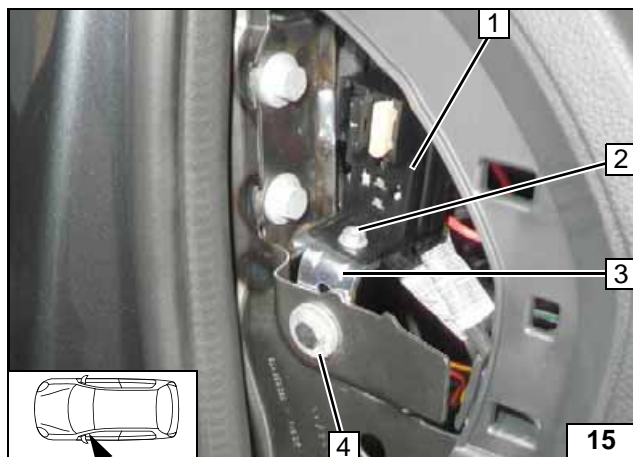

- 1 Passenger compartment relay and fuse holder
- 2 M5x16 bolt, large diameter washer [2x], nut
- 3 Angle bracket
- 4 M6x20 bolt, large diameter washer [2x], original vehicle hole, flanged nut

**Installing passenger compartment relay and fuse holder**

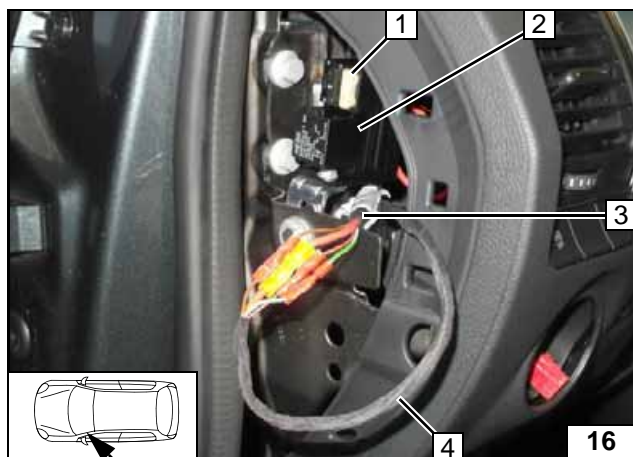

- 1 25A fuse F4
- 2 Relay K1
- 3 Passenger compartment relay and fuse holder wiring harness
- 4 Heater wiring harness

**Connecting same colour wires of wiring harnesses**

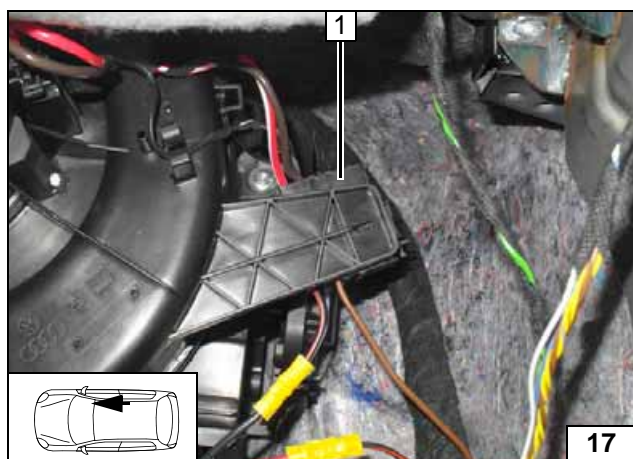

- 1 Detach connector T10n

**Connecting connector T10n**

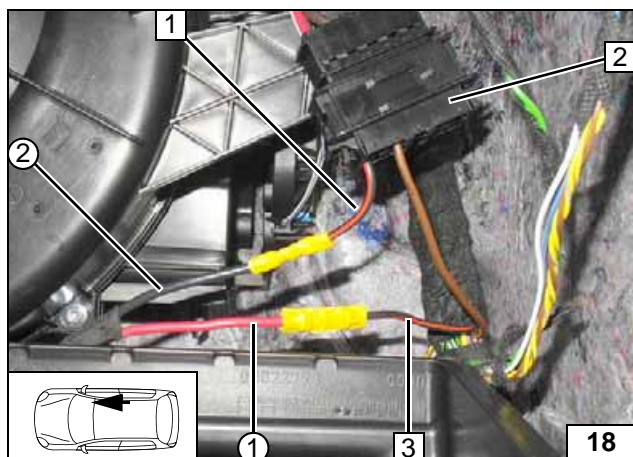

- 1 Black (sw) wire from connector T10n/pin 1
- 2 10-pin connector T10n
- 3 Black (sw) wire of fuse F24
- ① Red (rt) wire from K1/87a of fan wiring harness
- ② Black (sw) wire from K1/30 of fan wiring harness

**Connecting connector T10n**

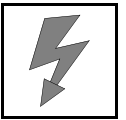

Fan Controller for Automatic Air-Conditioning

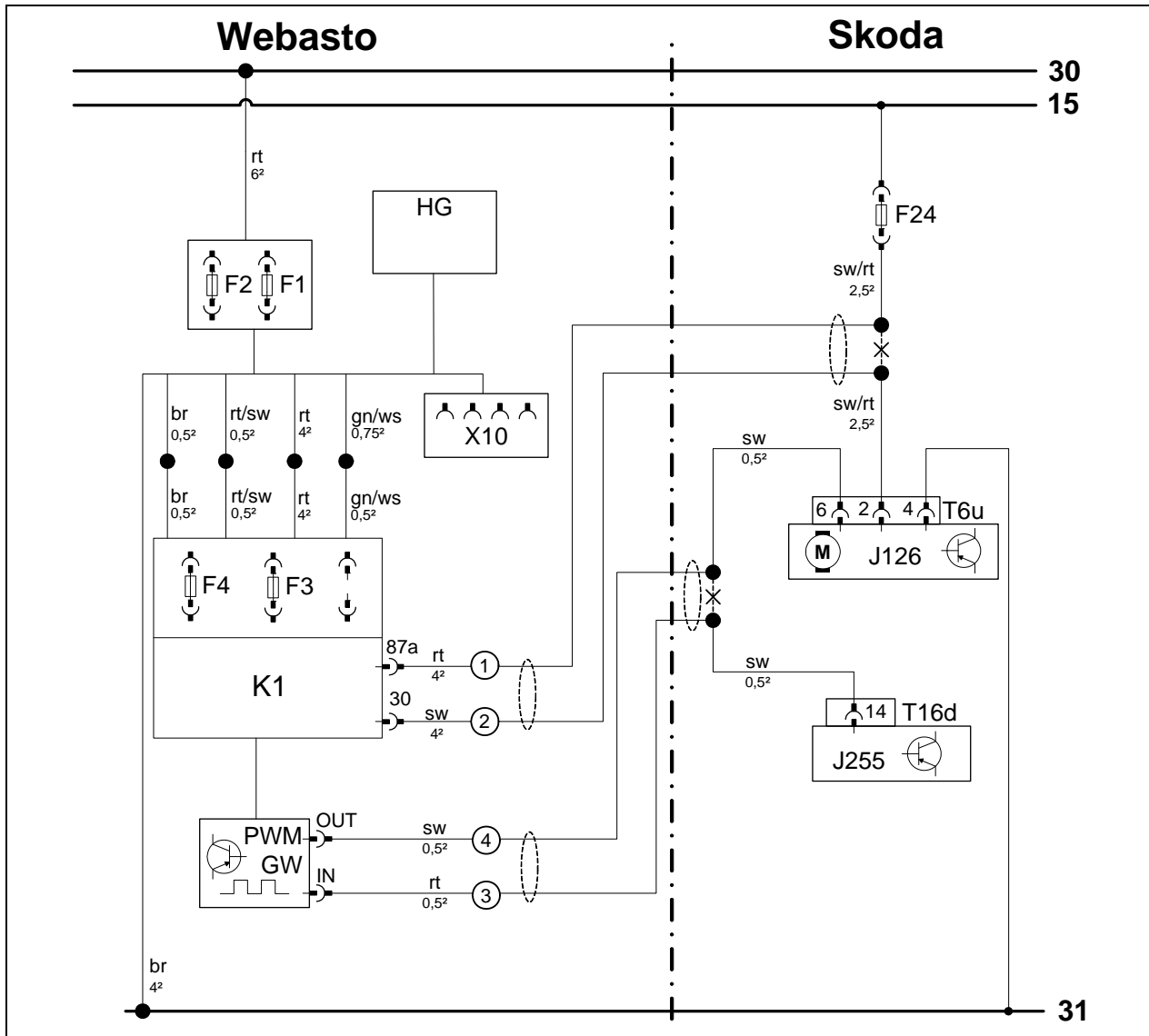

System wiring diagram

Webasto components		Vehicle components		Colours and symbols	
HG	TT-Evo heater	F24	30A fuse	rt	red
F1	20A fuse	J126	Fan unit	ws	white
F2	30A fuse	T6u	6-pin connector J126	sw	black
X10	4-pin connector of heater control	J255	A/C control unit	br	brown
F3	1A fuse	T16d	16-pin connector J255	gn	green
F4	25A fuse				
K1	Fan relay				
PWM GW	Pulse width modulator				
<b>PWM GW settings:</b>					
Duty cycle: 100% (DC)					
Frequency: not relevant					
Voltage: 3.3V					
Function: High side					
				X	Cutting point
Wiring colours may vary.					

Legend

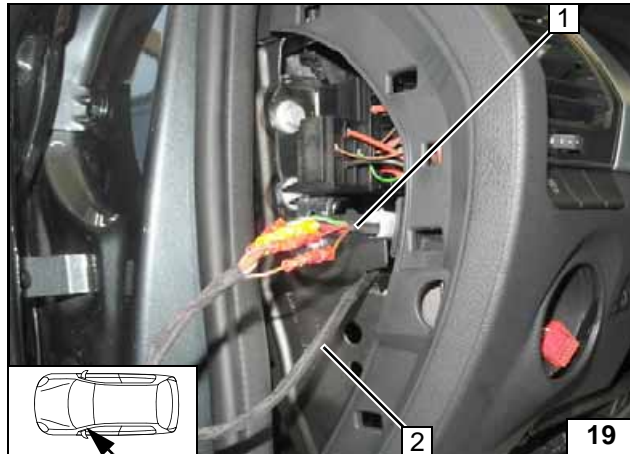
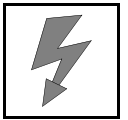

- 1 Passenger compartment relay and fuse holder wiring harness
- 2 Heater wiring harness

Connecting same colour wires of wiring harnesses

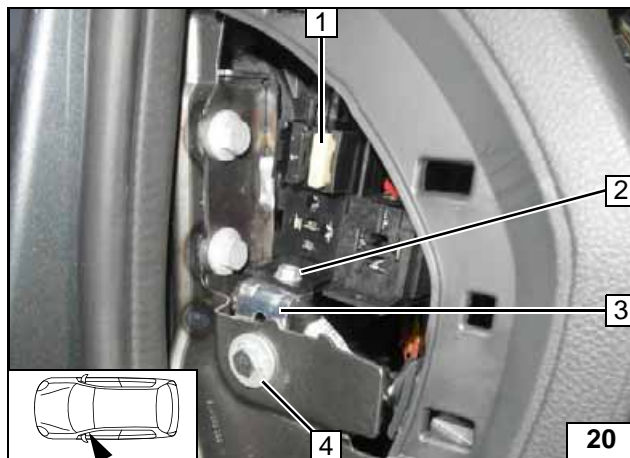

- 1 25A fuse F4
- 2 M5x16 bolt, large diameter washer [2x], nut
- 3 Angle bracket
- 4 M6x20 bolt, large diameter washer, original vehicle hole, flanged nut

Installing passenger compartment relay and fuse holder

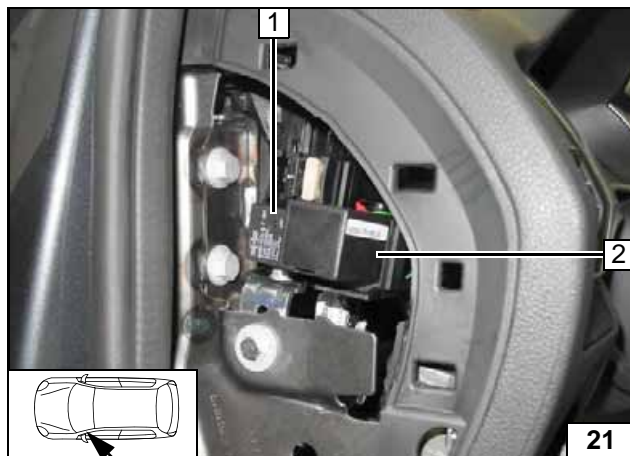

- 1 Relay K1
- 2 PWM GW

Installing PWM GW

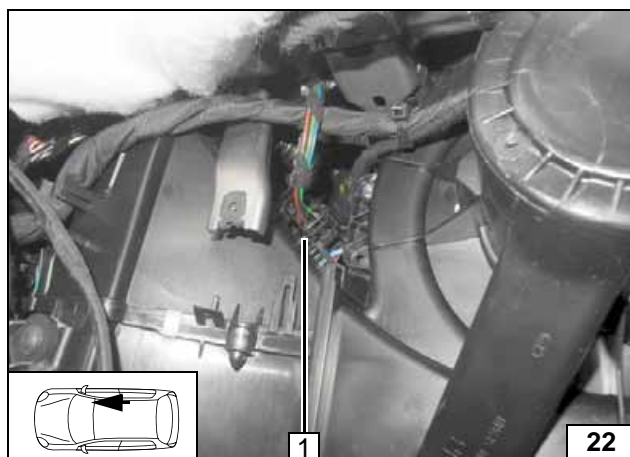

- 1 Pull off 6-pin connector T6u

Connecting fan unit

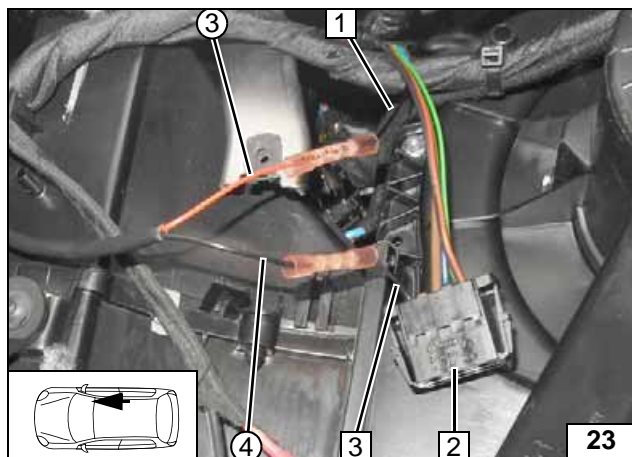

- 1 Black (sw) wire of connector T16d / pin 14
- 2 6-pin connector T6u
- 3 Black (sw) wire of connector T6u / pin 6
- ③ Red (rt) wire of PWM control wiring harness
- ④ Black (sw) wire of PWM control wiring harness

**Connect-  
ing fan unit**

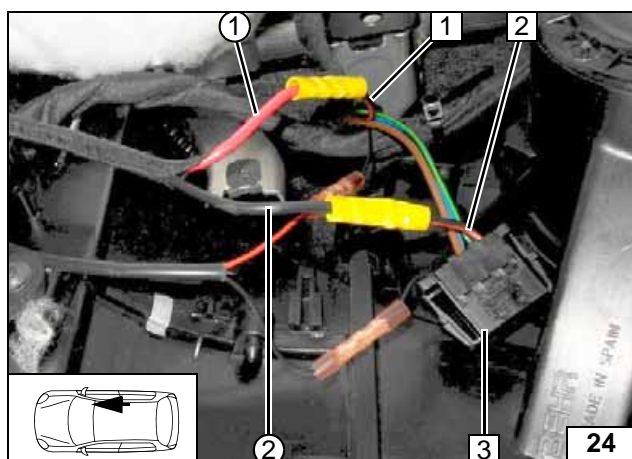

- 1 Black/red (sw/rt) wire of fuse F24
- 2 Black/red (sw/rt) wire of connector T6u / pin 2
- 3 6-pin connector T6u
- ① Red (rt) wire from K1/87a of fan wiring harness
- ② Black (sw) wire from K1/30 of fan wiring harness

**Connect-  
ing fan unit**



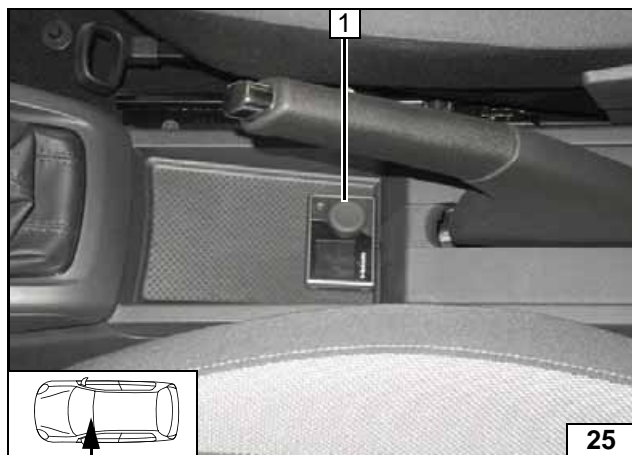

### MultiControl CAR Option

1 MultiControl CAR



Installing  
MultiControl  
CAR

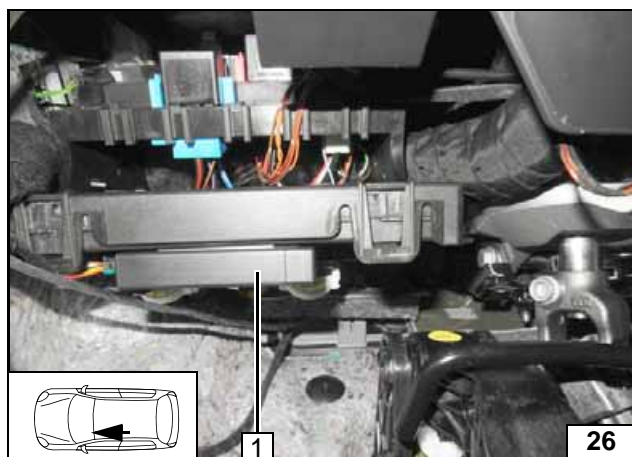

### Remote Option (Telestart)

Fasten receiver 1 with double-sided adhesive tape.



Installing  
receiver

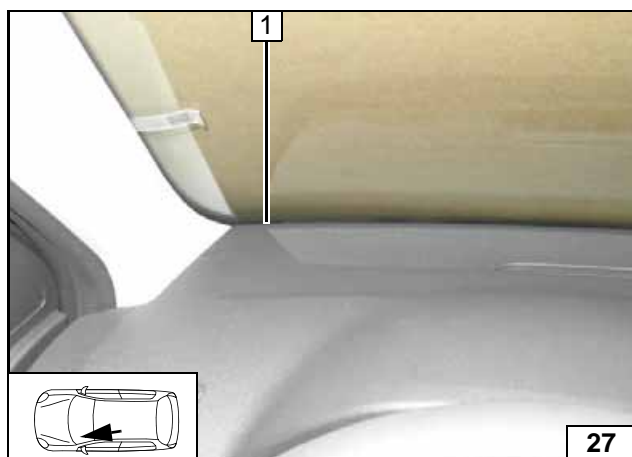

1 Aerial

Installing  
aerial

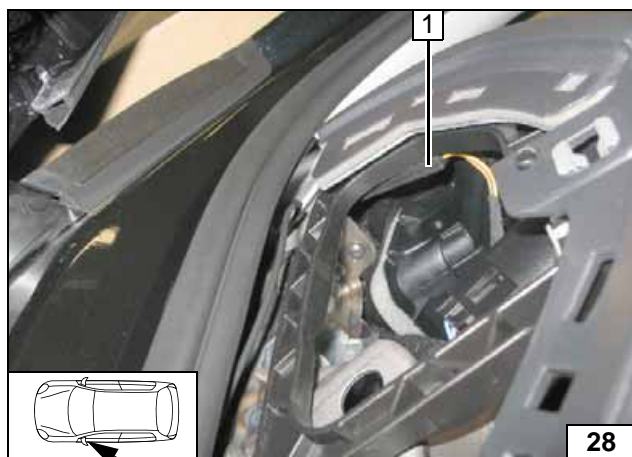

### Temperature sensor T100 HTM

Fasten temperature sensor 1 with double-sided adhesive tape.



Installing  
temperature  
sensor

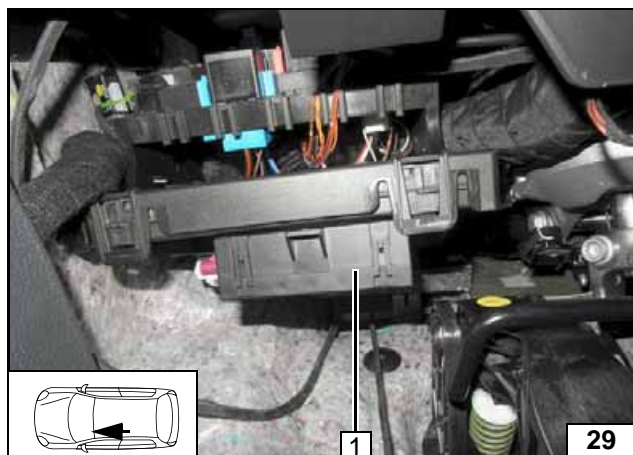

### ThermoCall Option

Fasten receiver 1 with double-sided adhesive tape.



**Installing receiver**

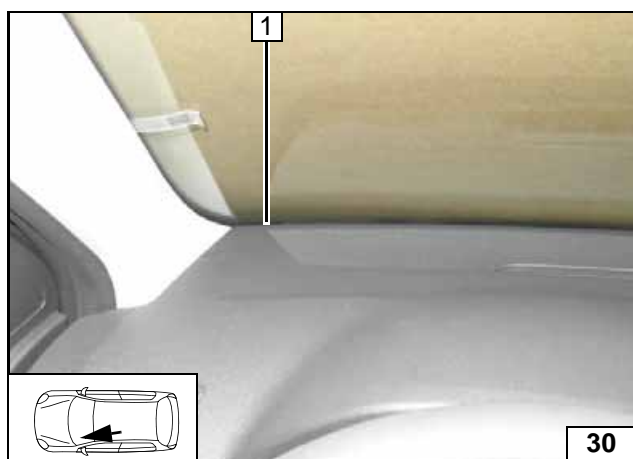

1 Aerial (optional)

**Installing aerial**

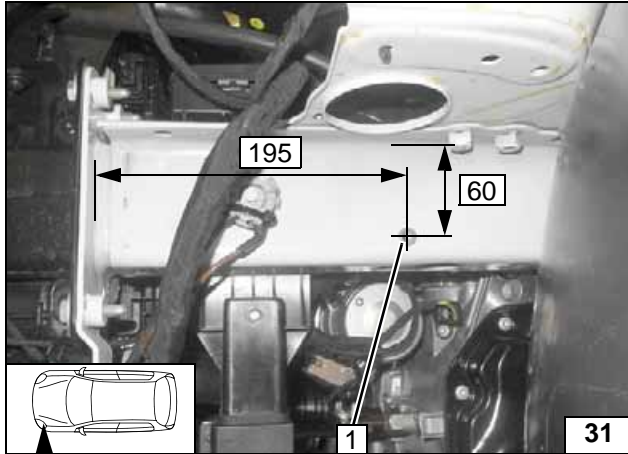
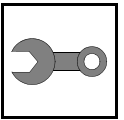

### Preparing Installation Location

- 1 9.1 mm dia. hole; M6 rivet nut

Installing rivet nut

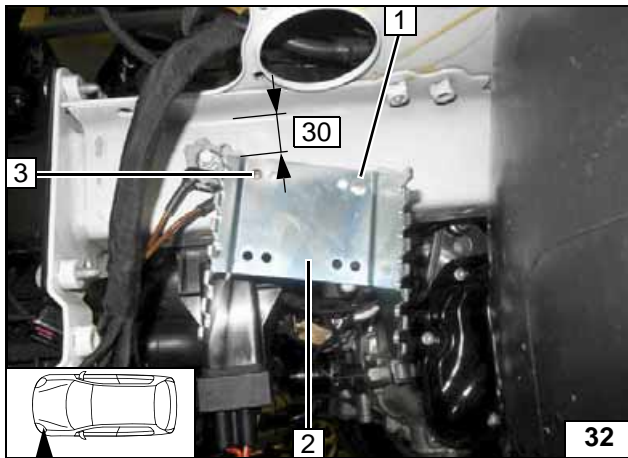

Loosely install bracket 2 and align as shown.

- 1 M6x20 bolt
- 3 Copy hole pattern



Copying hole pattern

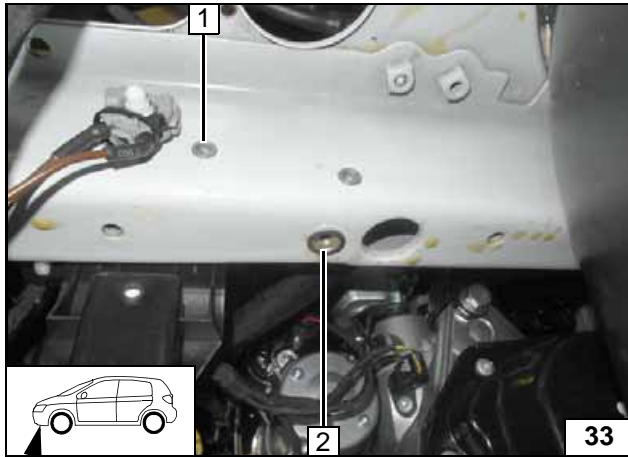

Remove bracket.

- 1 9.1 mm dia. hole; M6 rivet nut
- 2 Original vehicle hole, M10 rivet nut



Installing rivet nuts

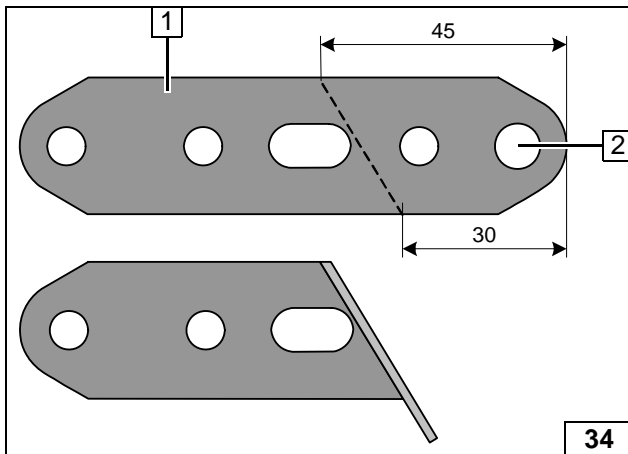

- 1 Angle down perforated bracket A by 90°
- 2 Drill hole to 8.5 mm dia.



Preparing perforated bracket

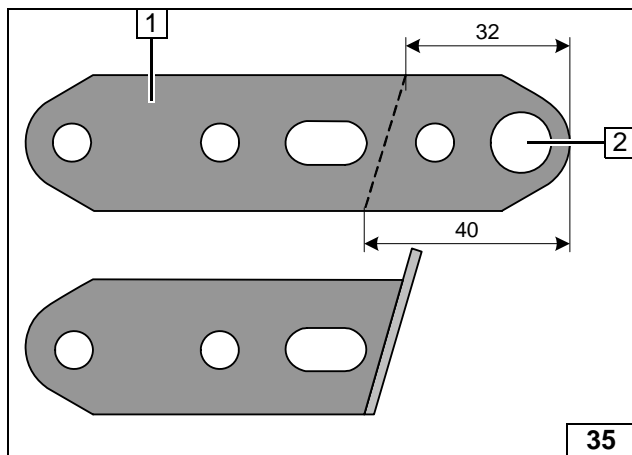

- 1 Angle down perforated bracket **B** by 90°
- 2 Drill hole to 10.5 mm dia.



**Preparing perforated bracket**

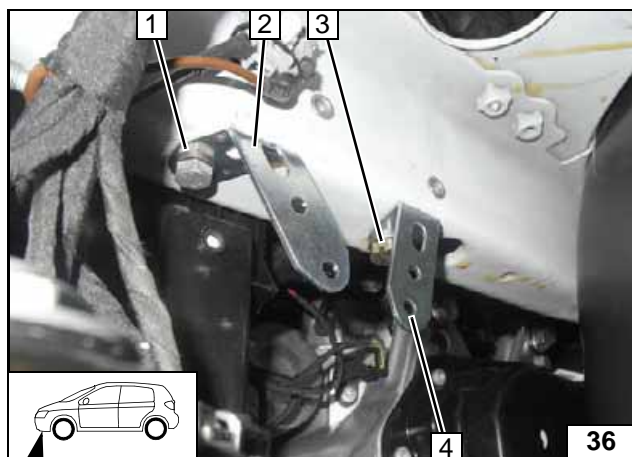

- 1 M8x20 bolt, spring lockwasher, existing threaded hole
- 2 Perforated bracket A
- 3 M10x16 bolt, spring lockwasher
- 4 Perforated bracket B

**Installing perforated brackets loosely**

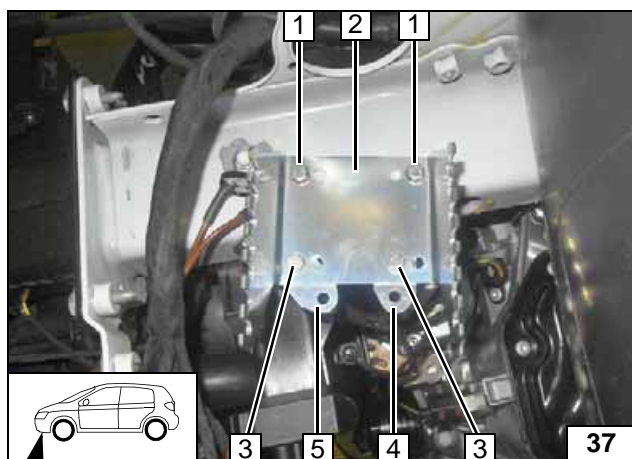

Tighten loose bolt connections.

- 1 M6x20 bolt, spring lockwasher [2x each]
- 2 Bracket
- 3 M6x12 bolt, flanged nut [2x each]
- 4 Perforated bracket B
- 5 Perforated bracket A



**Installing bracket**

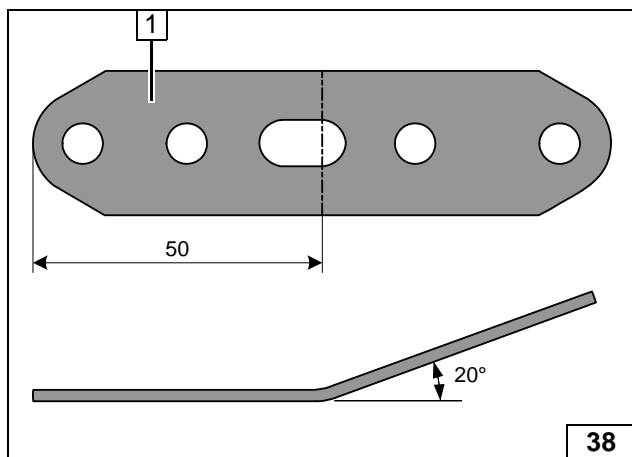

- 1 Perforated bracket **C**



**Preparing perforated bracket**

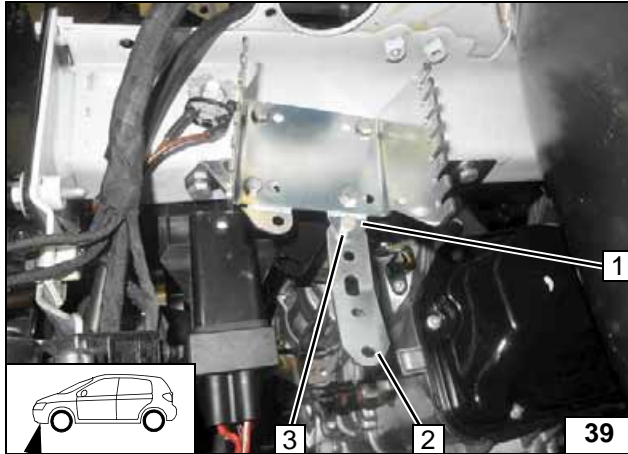
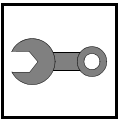

- 1 Perforated bracket B
- 2 Perforated bracket C
- 3 M6x12 bolt, flanged nut

Installing perforated bracket C

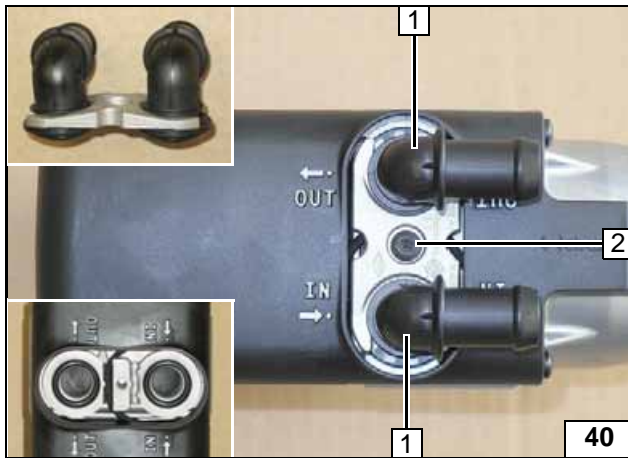

**Preparing Heater**

- 1 Water connection piece, sealing ring [2x each]
- 2 5x15 self-tapping bolt, retaining plate of water connection piece



Installing water connection piece

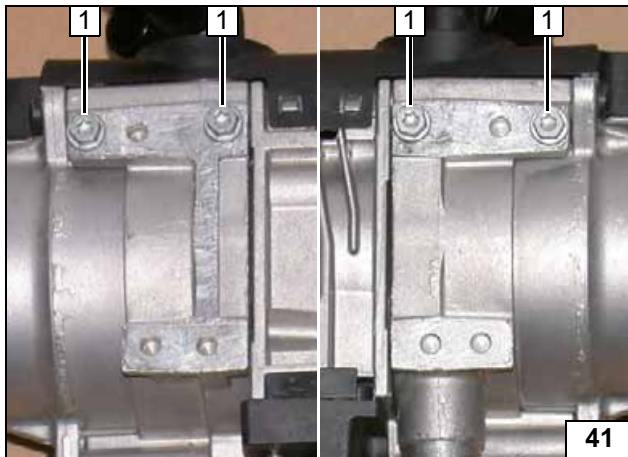

Screw 5x13 self-tapping bolts 1 [4x] into existing holes by a maximum of 3 thread turns.



Premounting bolts loosely

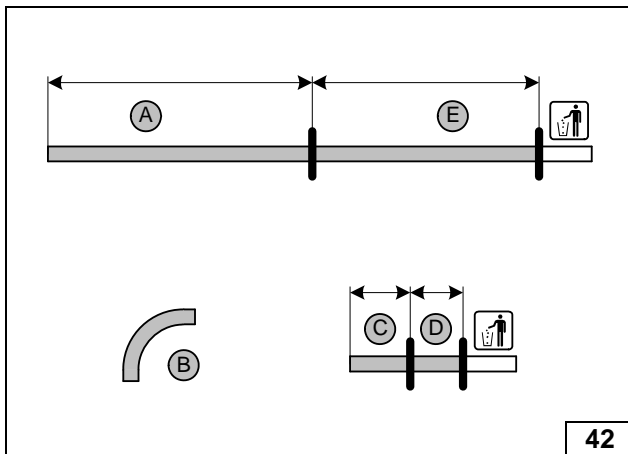

Hoses A, E = 15mm dia.  
Hoses C, D = 18mm dia.  
Hose B = 90°, 18mm dia. moulded hose

	1.0 MPI	1.2 TSI	1.4 TDI
A =	950	900	860
C =	60	60	60
D =	85	85	85
E =	950	930	930



Cutting hoses to length

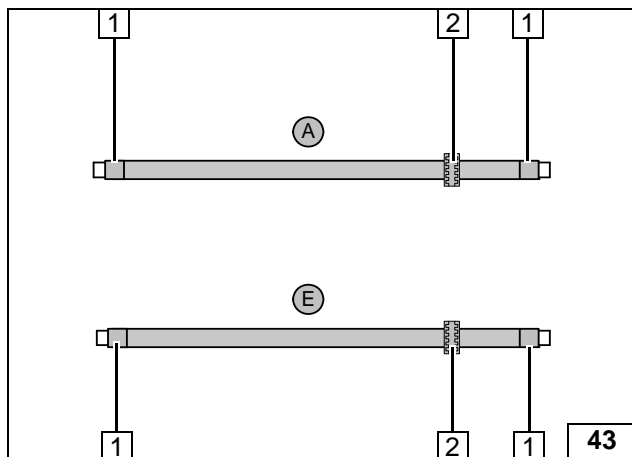

Slide on braided protection hoses and cut to length.



- 1 Cut heat shrink plastic tubing to size, 50 mm long [4x]
- 2 Black (sw) rubber isolator [2x]

**Installing braided protection hoses**

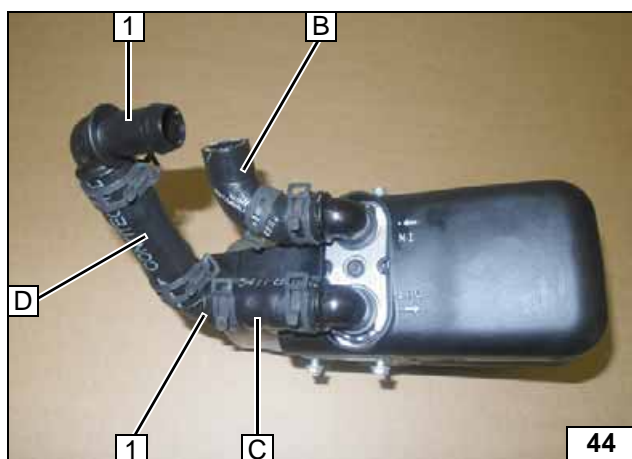

All spring clips = 25 mm dia.



- 1 90° 18x18 mm dia. connecting pipe [2x]

**Premounting hoses**

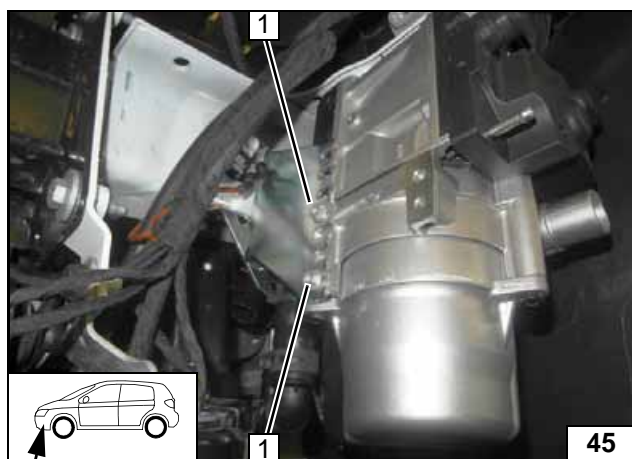

**Installing Heater**

- 1 Tighten 5x13 self-tapping bolt [2x]

**Installing heater**

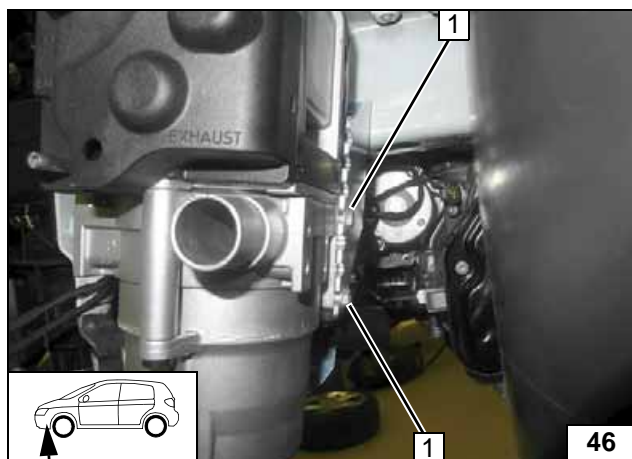

- 1 Tighten 5x13 self-tapping bolt [2x]

**Installing heater**

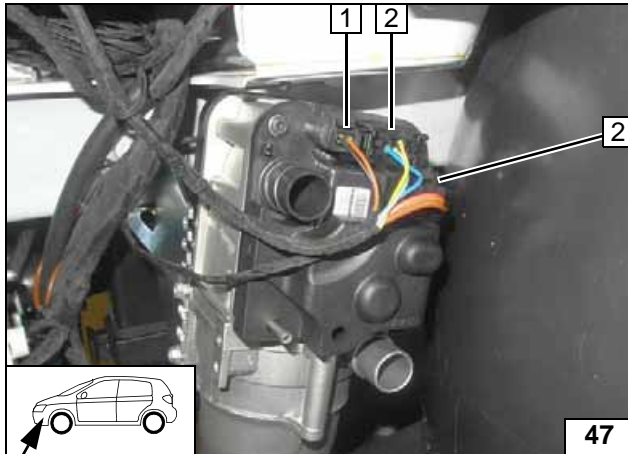
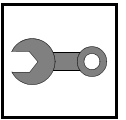

- 1 Connector of circulating pump wiring harness
- 2 Heater wiring harness connector [2x]

Installing wiring harnesses

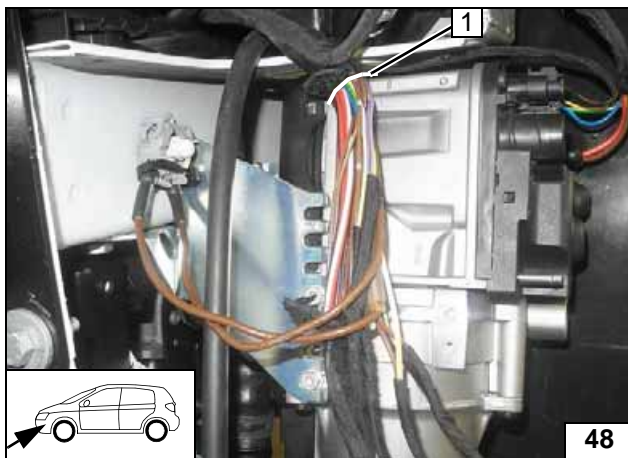

**Moving horns**

**Vehicles with two horns**

Remove insulation from original vehicle wiring harness up to marking 1.



Preparing wiring harness

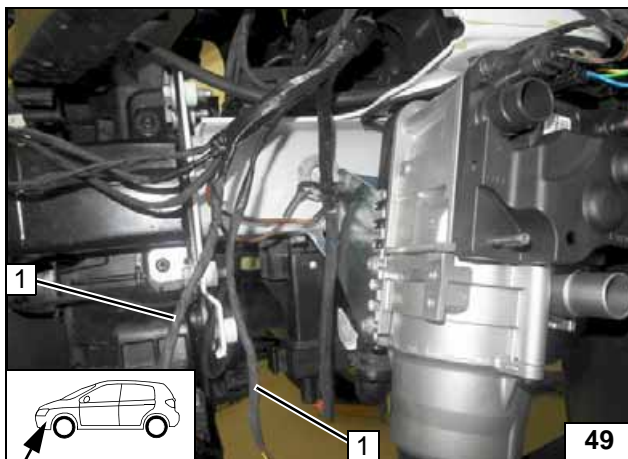

Separate original vehicle wiring harnesses and wrap them with new insulating tape as shown.

- 1 Wiring harness of horn [2x]



Preparing wiring harnesses

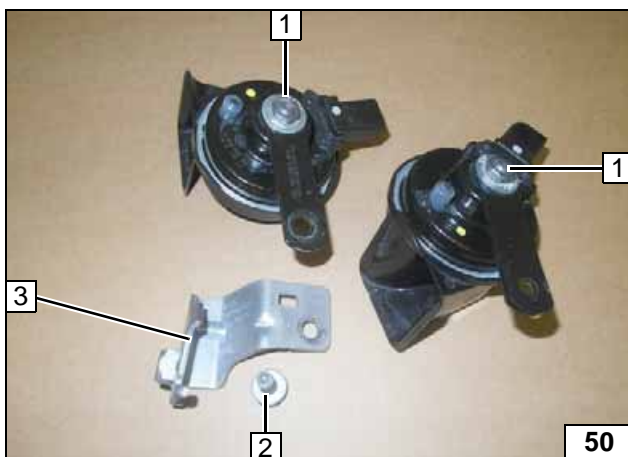

Detach screw fitting at position 1 [2x]. Discard original vehicle bolt 2 and horn bracket 3.



Disassembling horns (1 to 2 pieces)

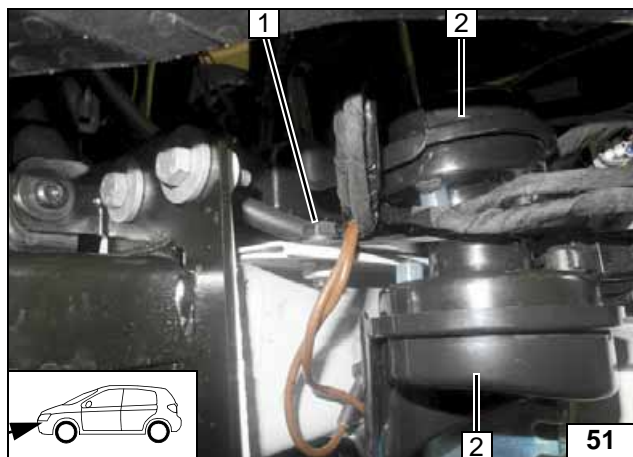

Install horn 2 [2x] with bracket loosely.

- 1 Original vehicle bolt, flanged nut



**Installing horns loosely**



Align lower horn 2, situated at the same installation location in case there is only one horn, as shown. Ensure sufficient distance from adjacent components, correct if necessary.

- 1 Install connector of horn wiring harness [2x]



**Aligning lower horn**

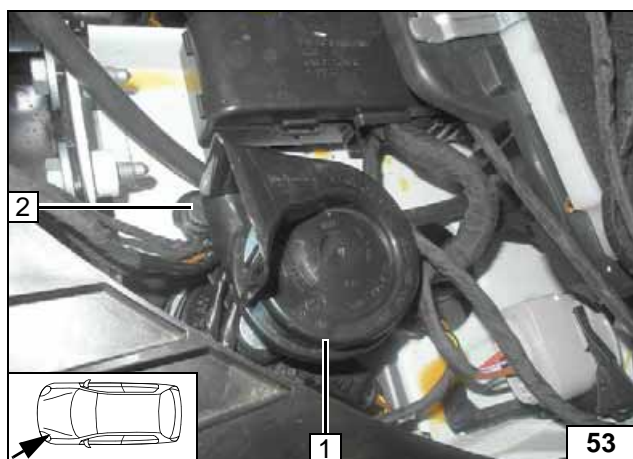

Align upper horn 1 as shown. Ensure sufficient distance from adjacent components, correct if necessary.

- 2 Tighten original vehicle bolt



**Aligning upper horn**

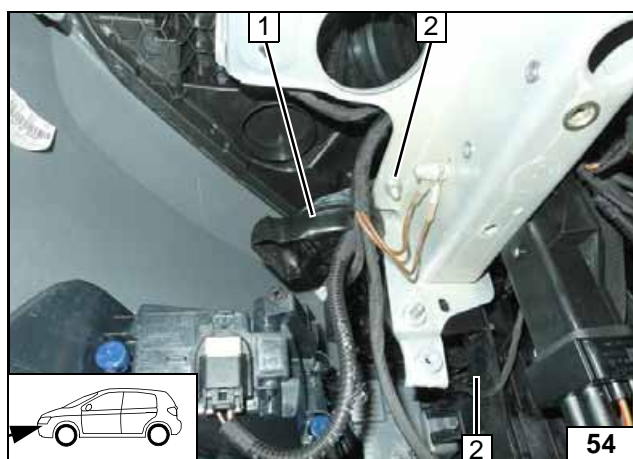

**Vehicles with one horn**

Install horn 1 with bracket as shown.

- 2 Original vehicle bolt, flanged nut



**Installing horn loosely**



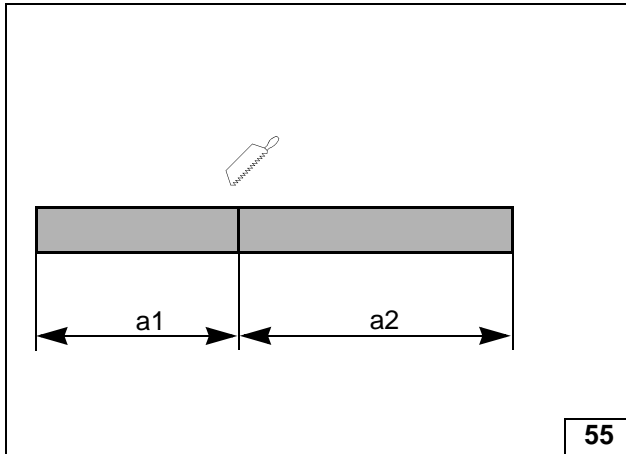
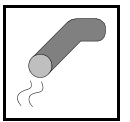

**Exhaust Part 1**

	Petrol	Diesel
a1	280	280
a2	370	160

**Preparing exhaust pipe**

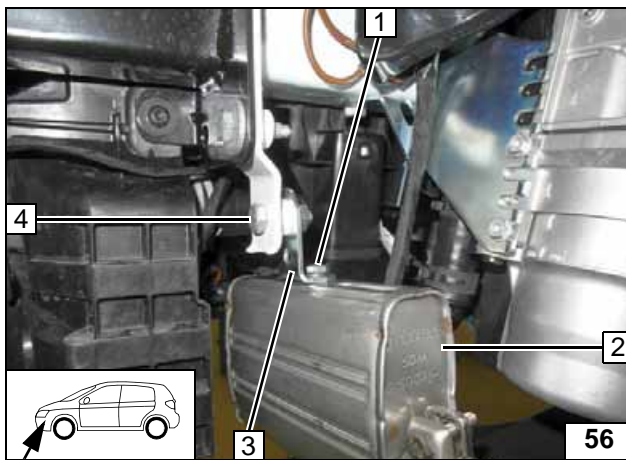

- 1 M6x16 bolt, spring lockwasher
- 2 Silencer
- 3 Angle bracket
- 4 8x30 bolt, flanged nut

**Installing silencer**

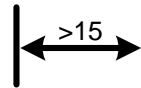
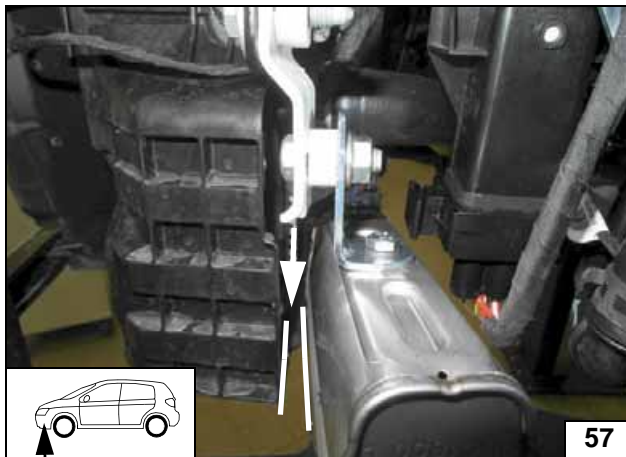

**Aligning silencer**

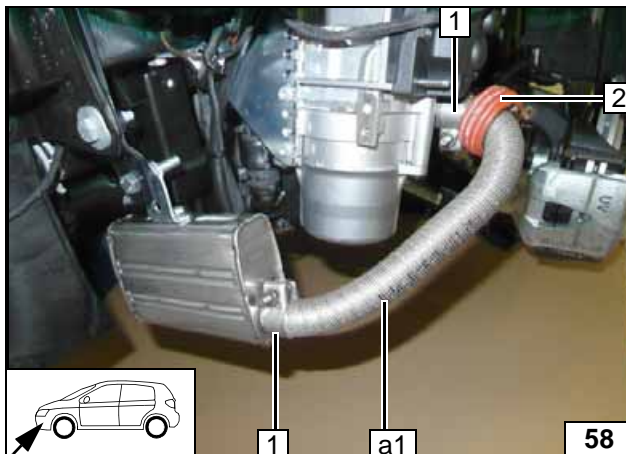

- 1 Hose clamp [2x]
- 2 Spacer bracket

**Installing exhaust pipe a1**



### Coolant Circuit for Petrol Vehicles



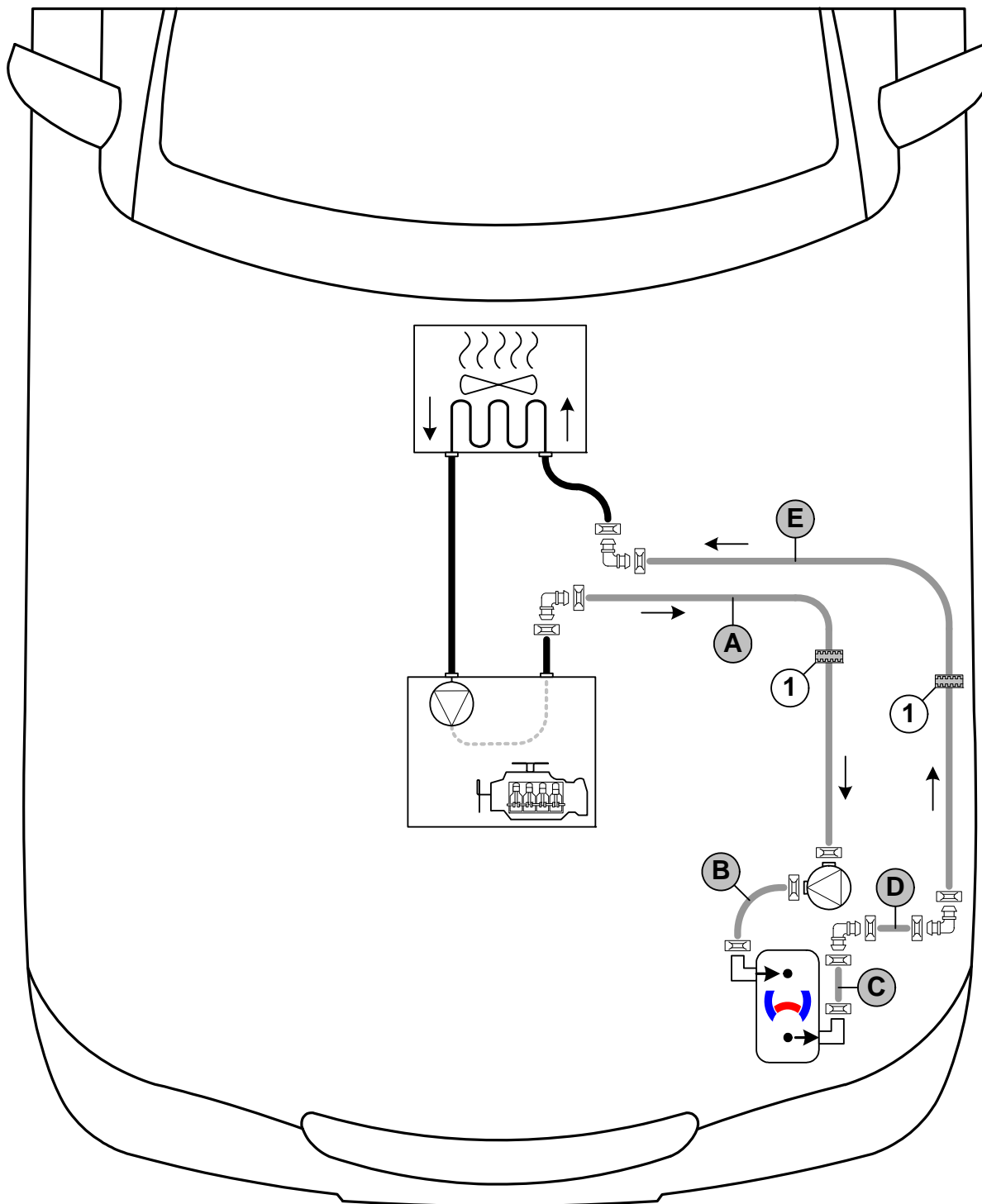

Any coolant running off should be collected in an appropriate container. Route hoses kink-free. Unless specified otherwise, always fasten using cable ties. Position clamps so that other hoses cannot be damaged. The heater must be filled with coolant when installing the hoses.

The connection should be modelled on an 'inline' circuit and based on the following diagram:



Hose routing diagram

All spring clips without a specific designation  = 25 mm dia. All connecting pipes  = 18x18 mm dia.  
1 = Black (sw) rubber isolator .



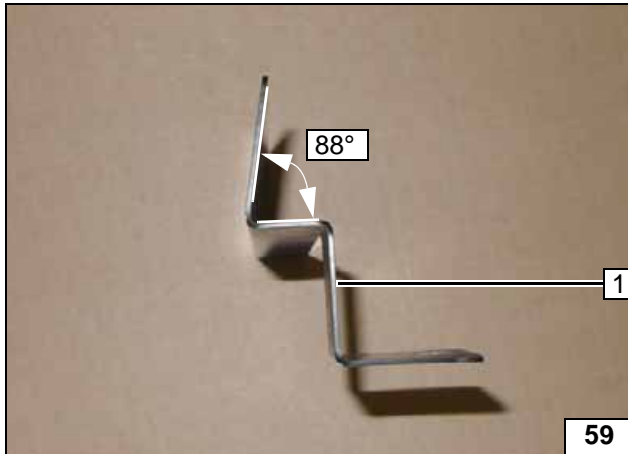

1 Guard plate

**Bending guard plate**

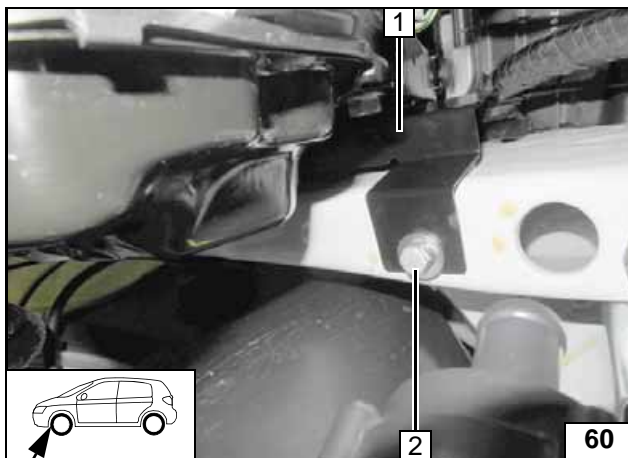

1 Guard plate  
2 M8x20 bolt, spring lockwasher, large diameter washer, existing threaded hole

**Installing guard plate**

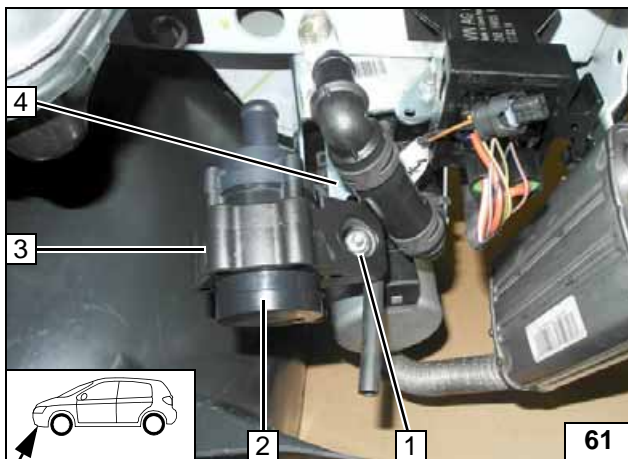

Use lower hole of perforated bracket C 4.

1 M6x25 bolt, flanged nut  
2 Circulating pump  
3 Circulating pump mount



**Installing circulating pump**

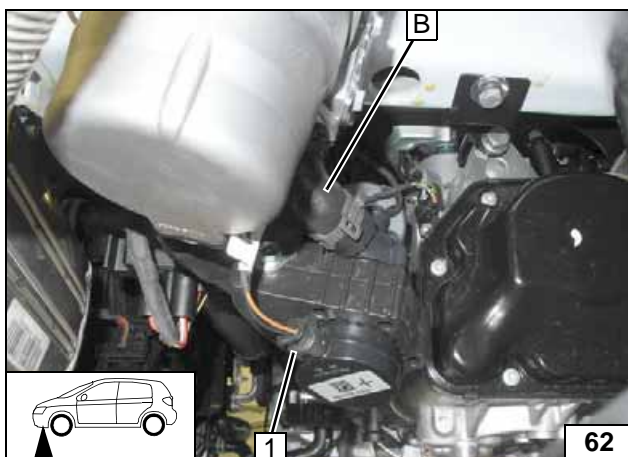

1 Connector of circulating pump wiring harness

**Connecting circulating pump**

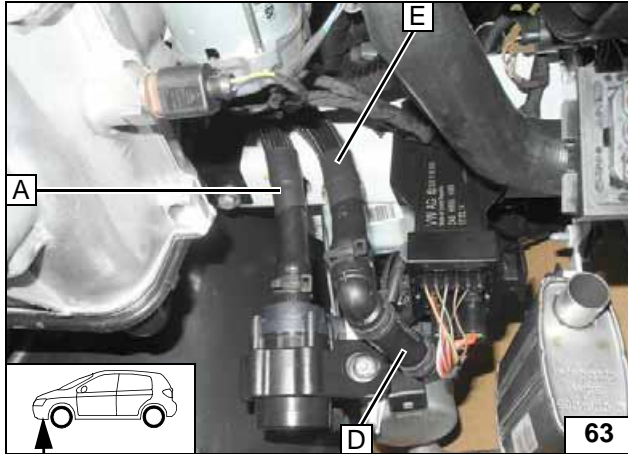
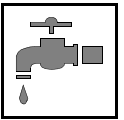

Connect-  
ing heater

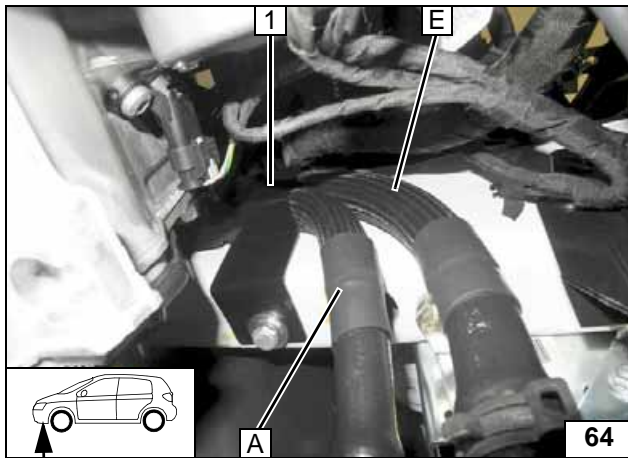

Route hose **A** and **E** on the frame side member behind the guard plate **1**.



Routing in  
engine  
compartment

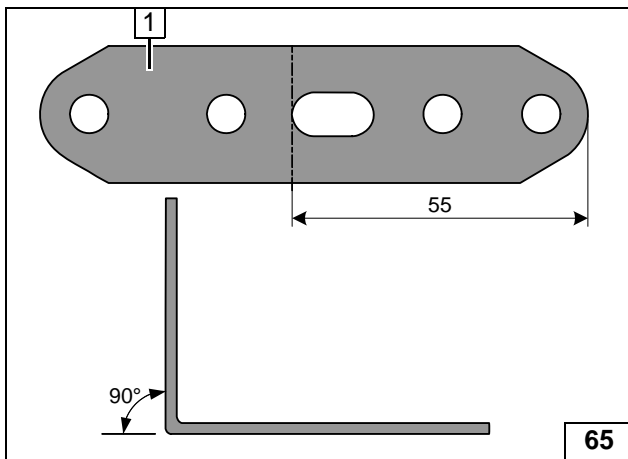

1 Perforated bracket



Preparing  
perforated  
bracket

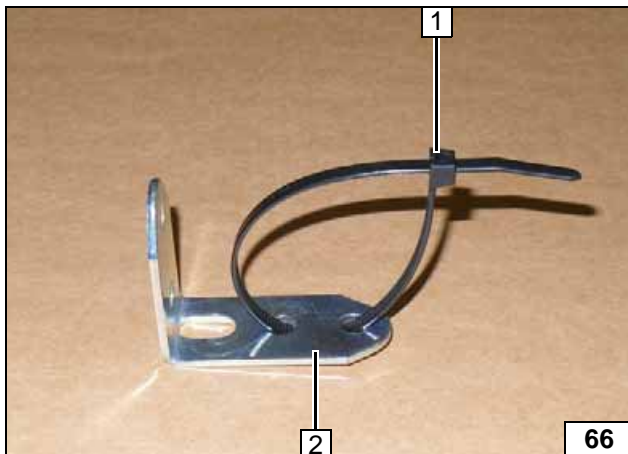

1 Cable tie through both holes  
2 Perforated bracket

Preparing  
perforated  
bracket

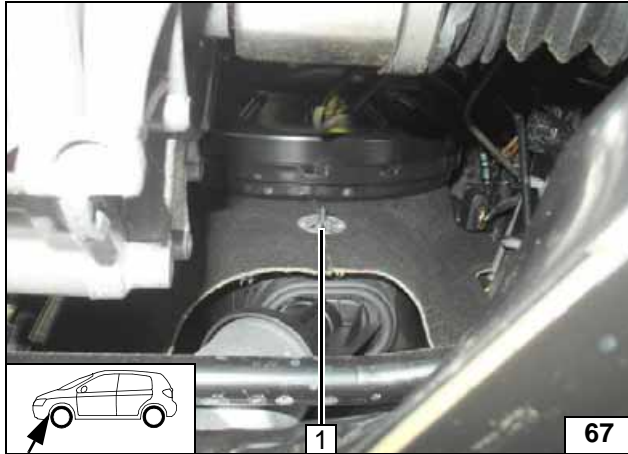

- 1 Discard retaining clamp

Removing retaining clamp

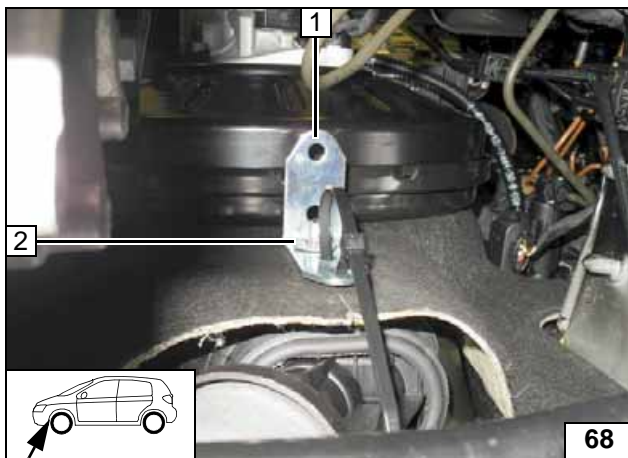

- 1 Perforated bracket
- 2 Plate nut on original vehicle stud bolt

Installing perforated bracket

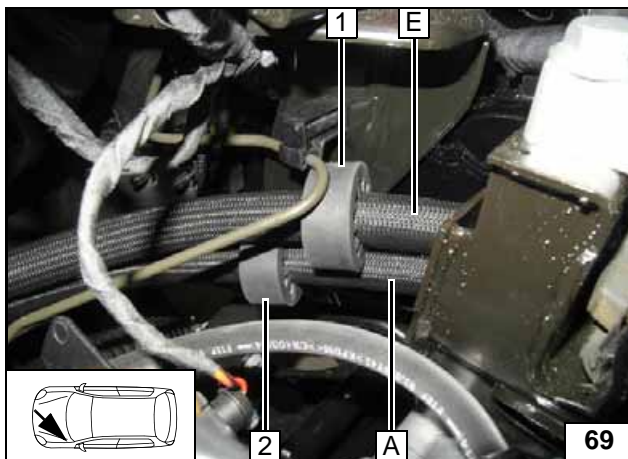

- 1 Align black (sw) rubber isolator with coupling line
- 2 Black (sw) rubber isolator

Routing in engine compartment

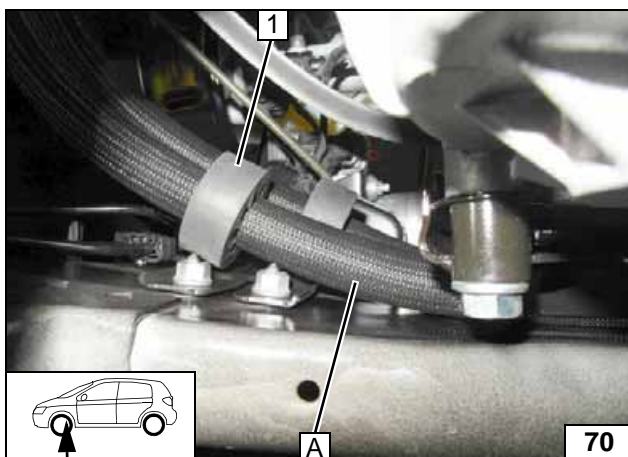

- 1 Align black (sw) rubber isolator with original vehicle bolt

Routing in engine compartment

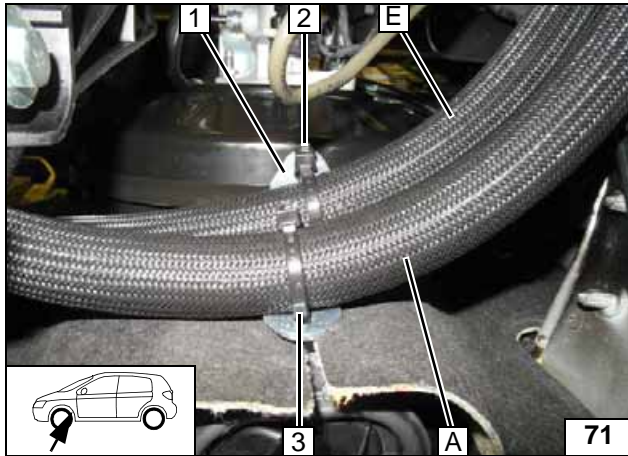

Route cable tie 2 through free holes of perforated bracket 1. Close cable tie 2 and 3.



Routing in engine compartment

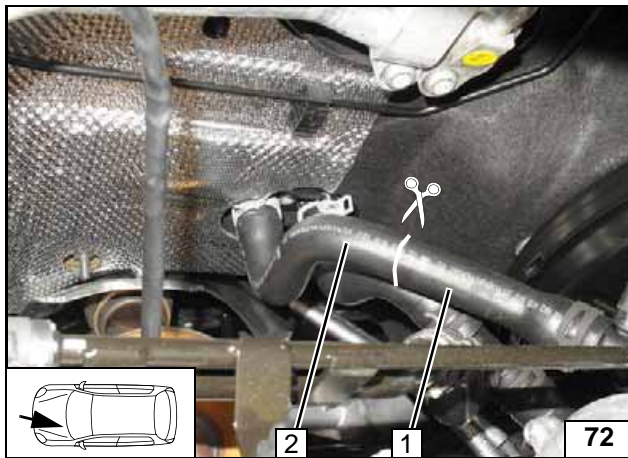

**1.0 MPI**

Cut off hose of engine outlet/heat exchanger inlet at the marking.



- 1 Engine outlet hose section
- 2 Heat exchanger inlet hose section

**Cutting point**

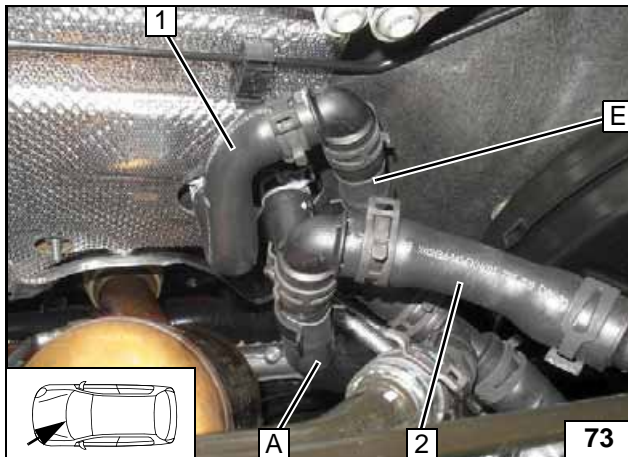

- 1 Hose on heat exchanger inlet
- 2 Hose of engine outlet

**Connecting engine outlet / heat exchanger inlet**

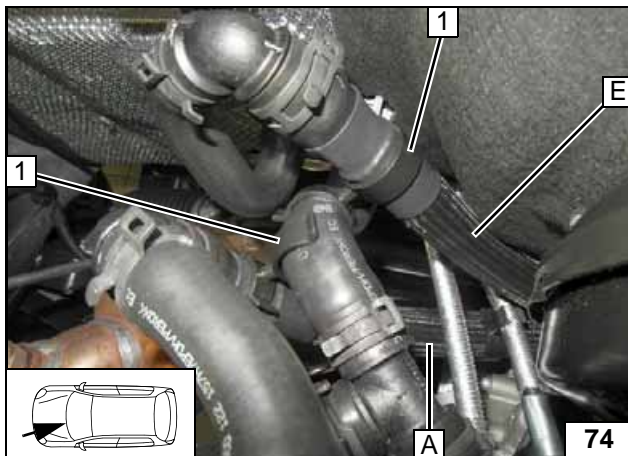

- 1 20x20 hose bracket [2x]

**Inserting hose bracket**

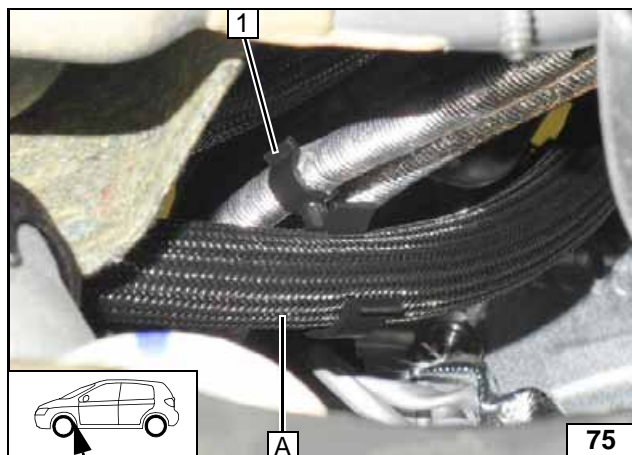

- 1 10x20 hose bracket between gear-shift cable and hose A

Inserting hose bracket

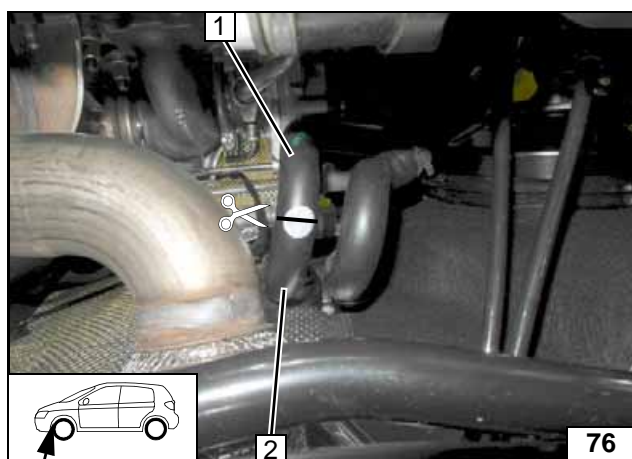

1.2 TSI

Cut off hose of engine outlet/heat exchanger inlet at the marking.

- 1 Engine outlet hose section
- 2 Heat exchanger inlet hose section

Cutting point

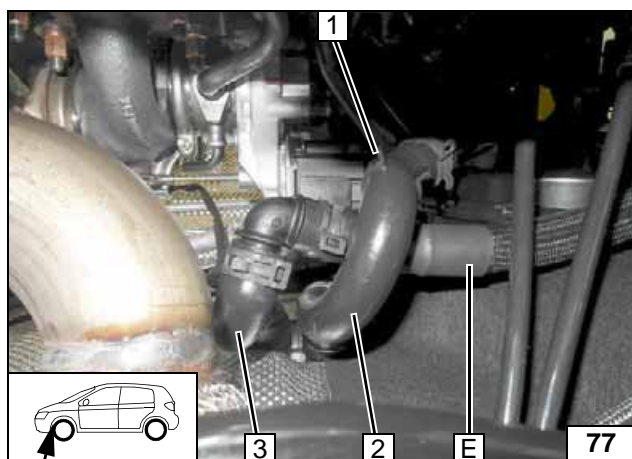

- 1 20x20 hose bracket between hose of heat exchanger outlet 2 and hose E
- 3 Heat exchanger inlet hose section

Connecting heat exchanger inlet

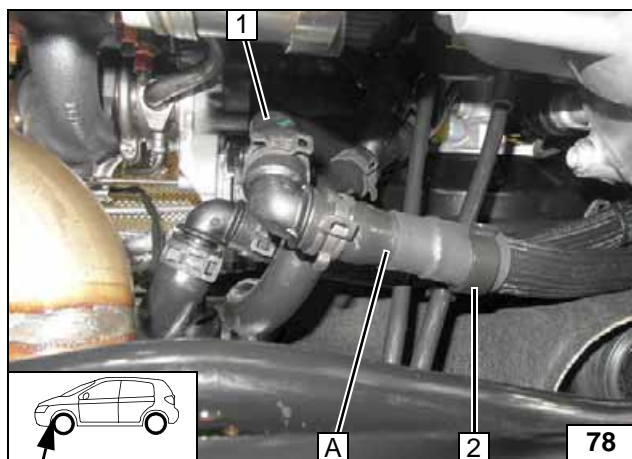

- 1 Engine outlet hose section
- 2 10x20 hose bracket between gear-shift cable and hose A

Connecting engine outlet

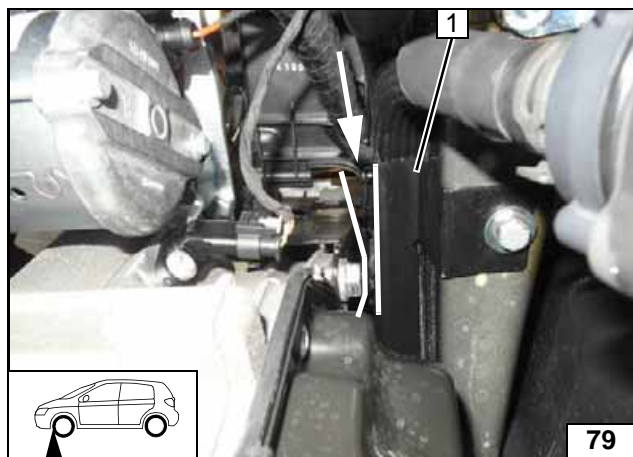

All vehicles

1 Guard plate

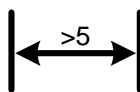

Aligning guard plate





### Coolant Circuit for Diesel Vehicles





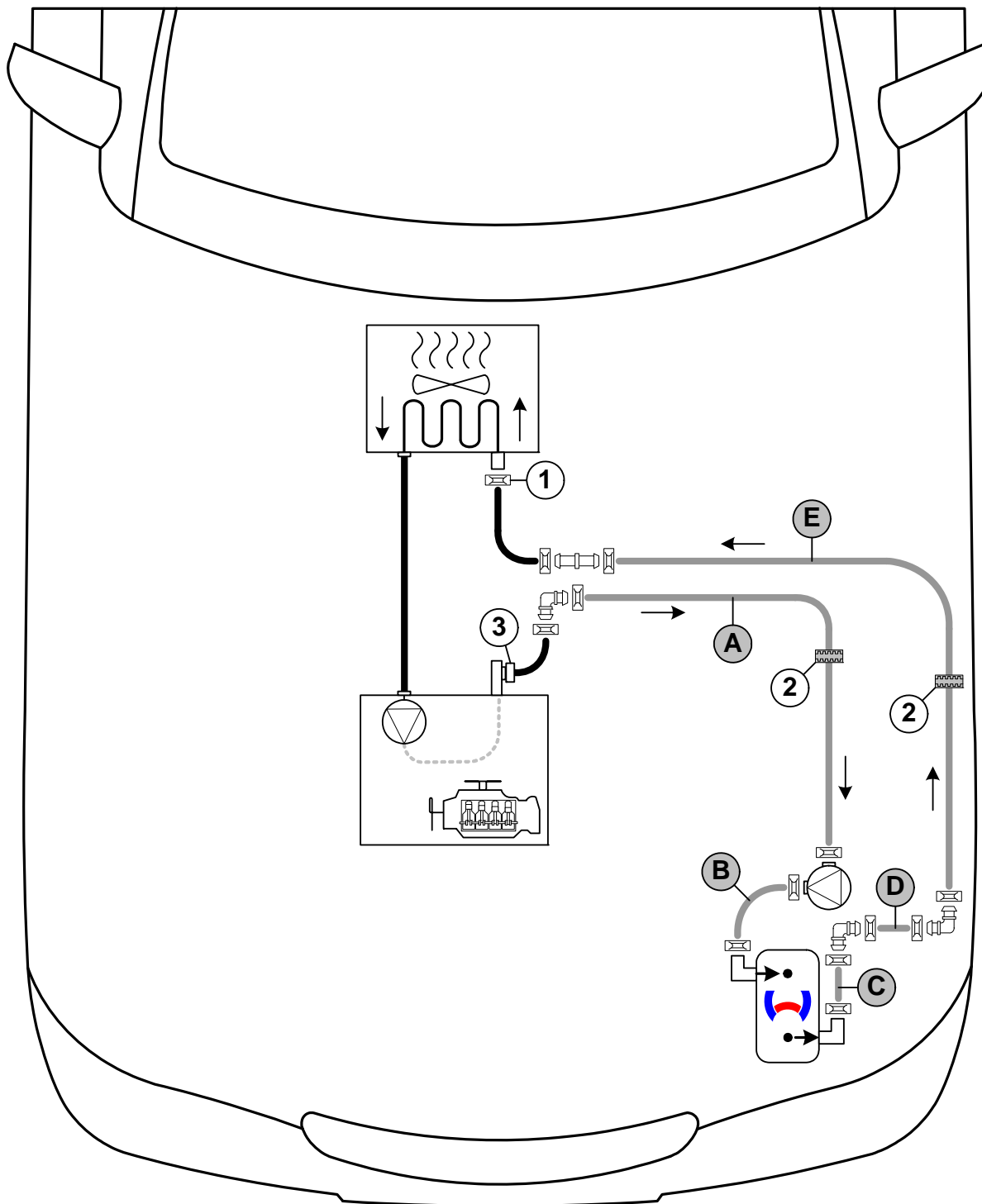

Any coolant running off should be collected in an appropriate container. Route hoses kink-free. Unless specified otherwise, always fasten using cable ties. Position clamps so that other hoses cannot be damaged. The heater must be filled with coolant when installing the hoses.

The connection should be modelled on an 'inline' circuit and based on the following diagram:



Hose routing diagram

All spring clips without a specific designation  = 25 mm dia. **1** = Original vehicle spring clip .  
**2** = Black (sw) rubber isolator . **3** = Coupling piece of engine outlet.  
 All connecting pipes  and  = 18x18 mm dia.



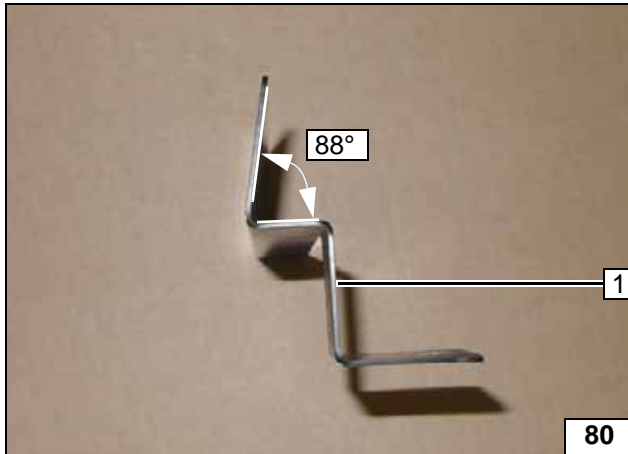

1 Guard plate

**Bending guard plate**

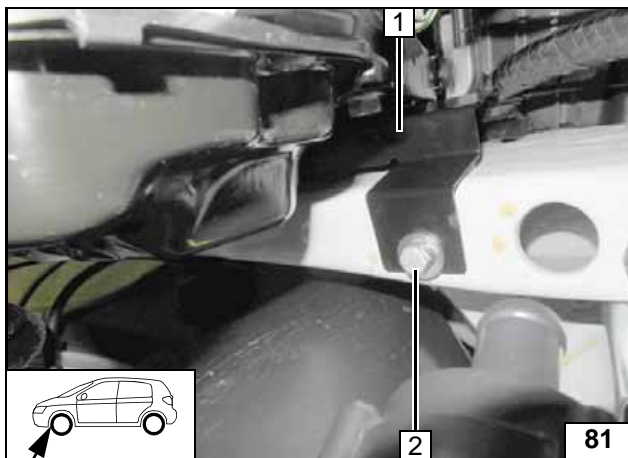

1 Guard plate  
2 M8x20 bolt, spring lockwasher, large diameter washer, existing threaded hole

**Installing guard plate**

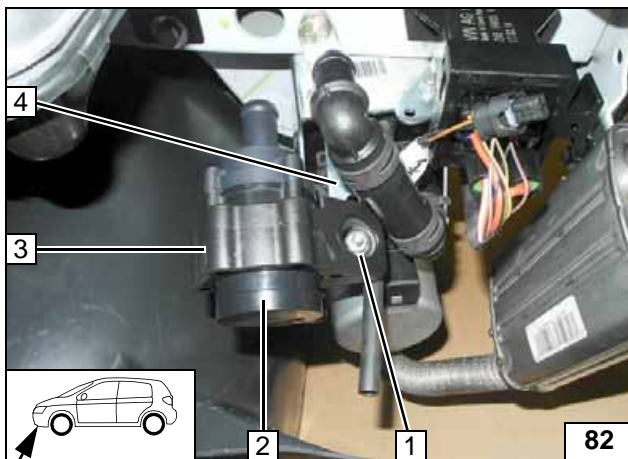

Use lower hole of perforated bracket C 4.



1 M6x25 bolt, flanged nut  
2 Circulating pump  
3 Circulating pump mount

**Installing circulating pump**

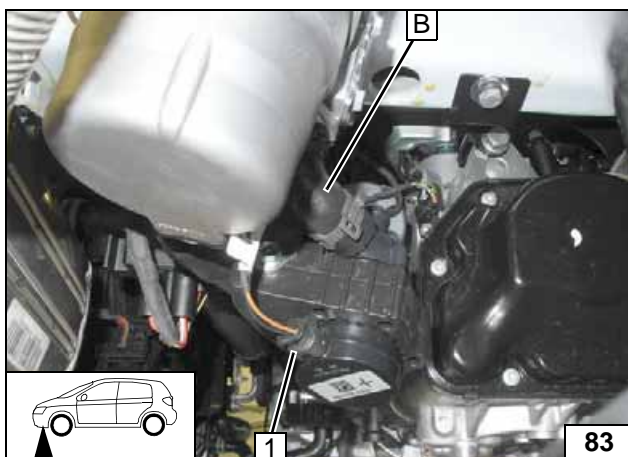

1 Connector of circulating pump wiring harness

**Connecting circulating pump**

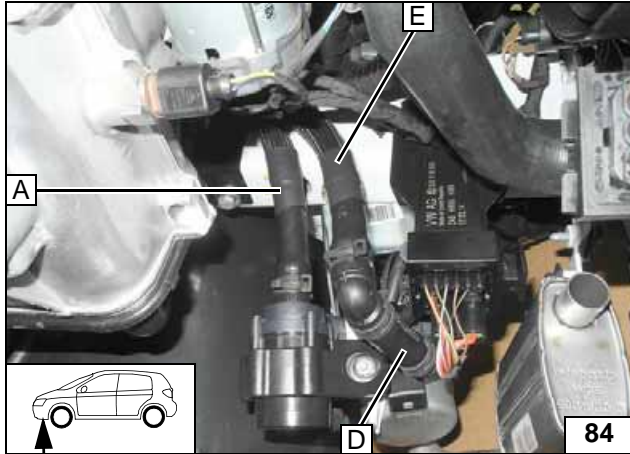
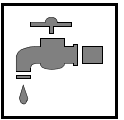

Connect-  
ing heater

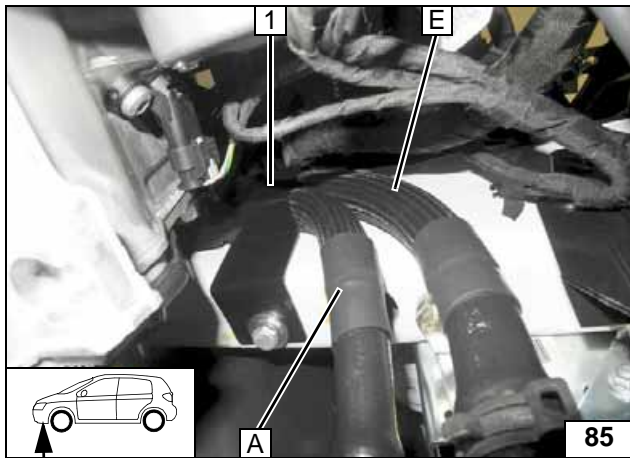

Route hose **A** and **E** on the frame side member behind the guard plate **1**.



Routing in  
engine  
compartment

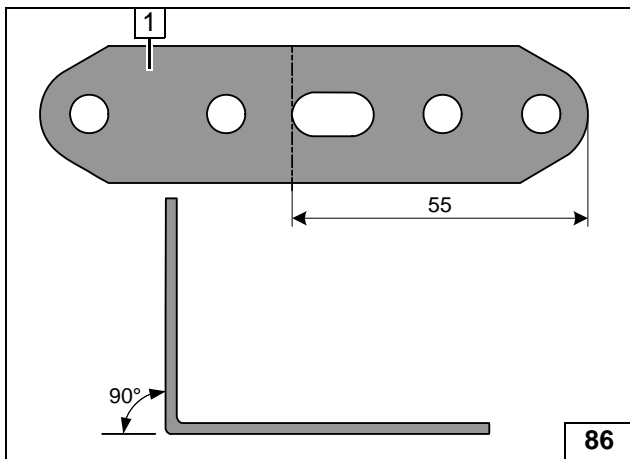

1 Perforated bracket



Preparing  
perforated  
bracket

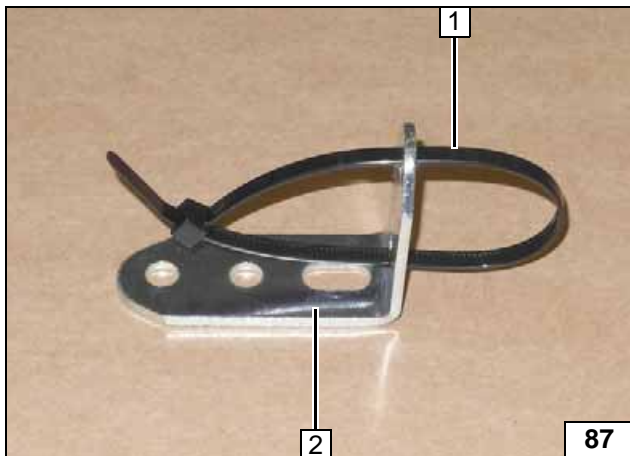

- 1 Cable tie through both holes, don't tighten
- 2 Perforated bracket

Preparing  
perforated  
bracket



1 Discard retaining clamp

Removing retaining clamp

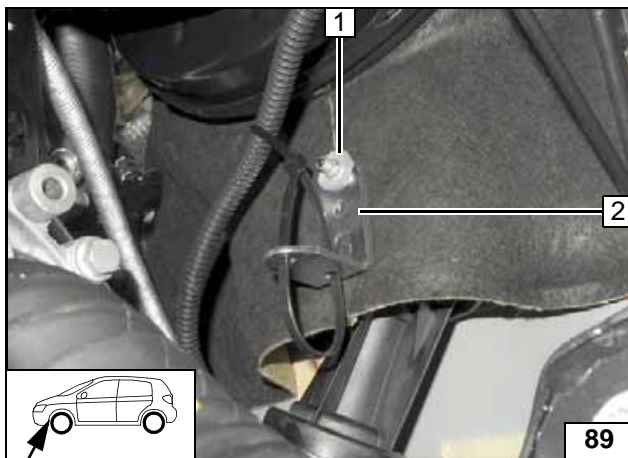

1 Plate nut on original vehicle stud bolt  
2 Perforated bracket

Installing perforated bracket

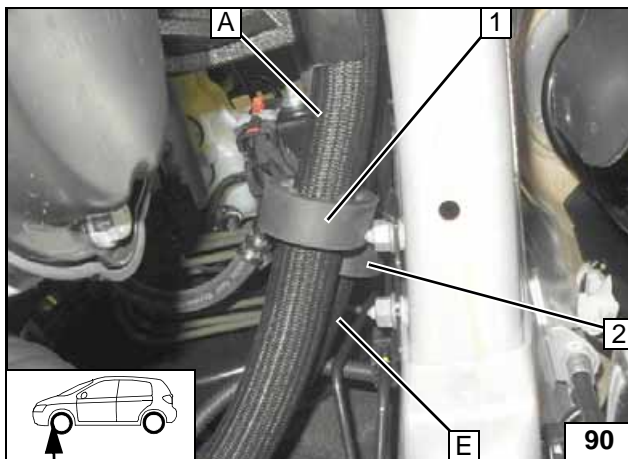

Slide black (sw) rubber isolator 2 onto hose E and align with coupling line. Slide black (sw) rubber isolator 1 onto hose A and align with original vehicle bolt.



Routing in engine compartment

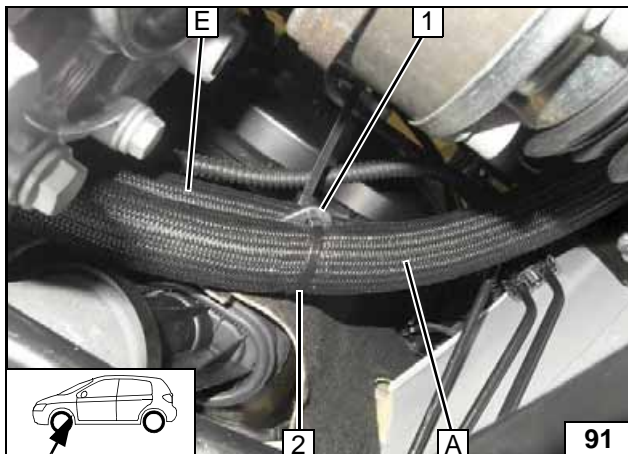

Route hose E above and hose A under perforated bracket 1 through cable tie 2. Align hoses, tighten cable tie 2.



Routing in engine compartment

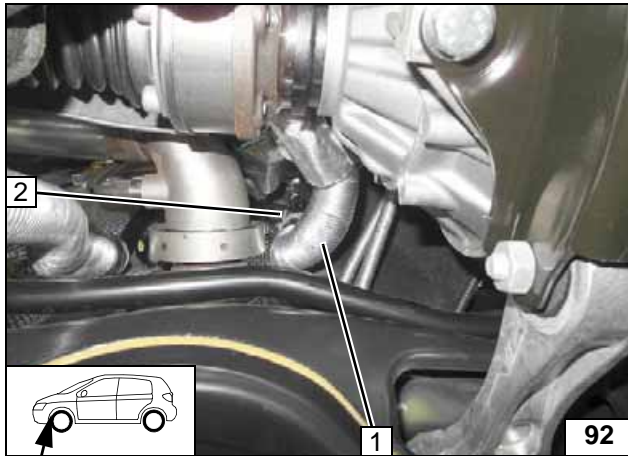

Remove hose on engine outlet / heat exchanger inlet **1** with coupling piece of engine outlet. Spring clip **2** will be reused.



**Cutting point**

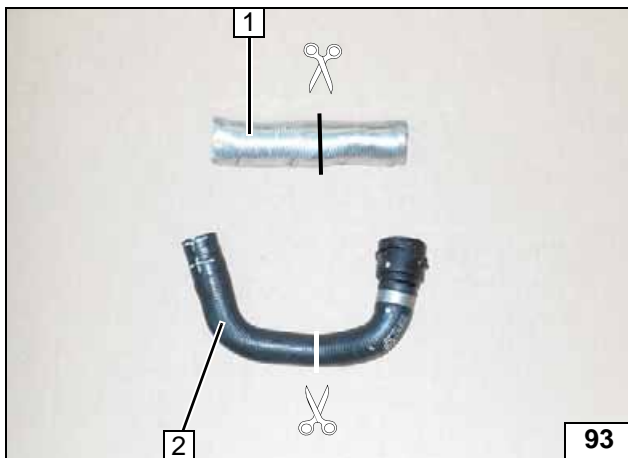

Pull off heat protection hose **1** and cut at the marking.  
Cut hose on engine outlet / heat exchanger inlet **2** at the marking.



**Cutting point**



- 1** Engine outlet hose section with heat protection hose
- 2** Heat exchanger inlet hose section with heat protection hose

**Cutting point**

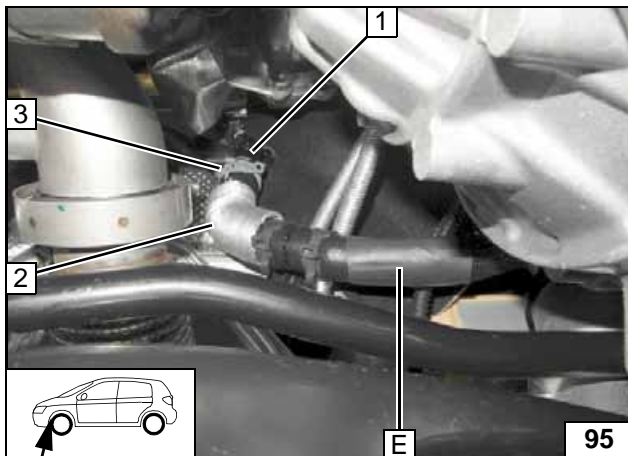

Slide heat protection hose onto heat exchanger inlet hose section **2**.



- 1** Connection piece of heat exchanger inlet
- 3** Original vehicle spring clip

**Connecting heat exchanger inlet**

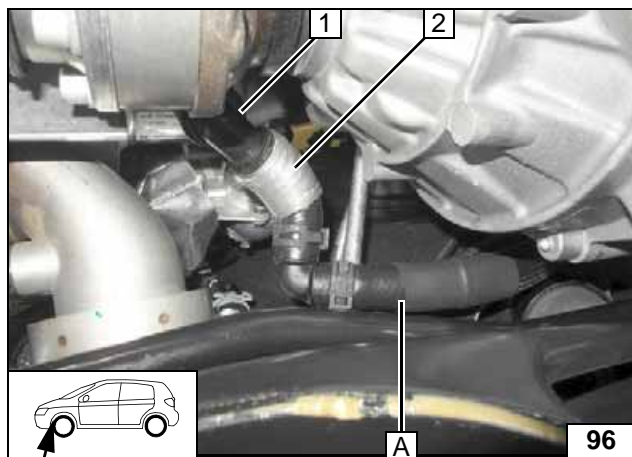

Slide heat protection hose onto engine outlet hose section 2. Align hoses. Ensure sufficient distance from adjacent components, correct if necessary.

- 1 Coupling piece of engine outlet



**Connect-  
ing engine  
outlet**

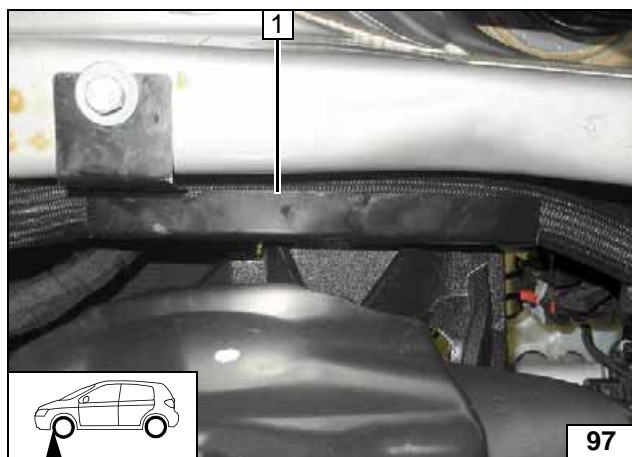

Ensure sufficient distance from adjacent components, correct if necessary.

- 1 Hose bracket



**Aligning  
hose brack-  
et**

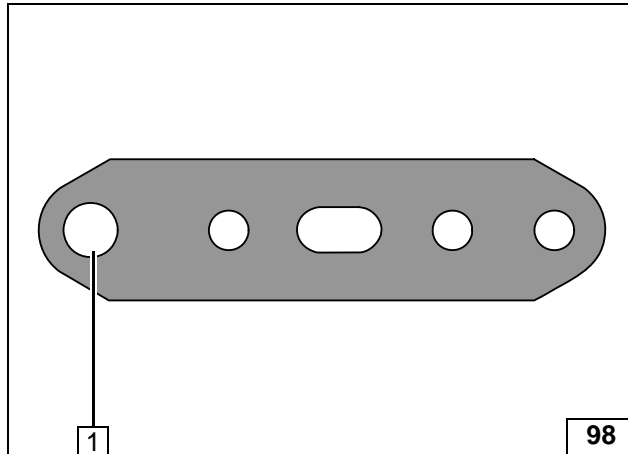
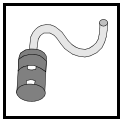

### Combustion Air

- 1 Drill hole to 8.5 mm dia.



#### Preparing perforated bracket

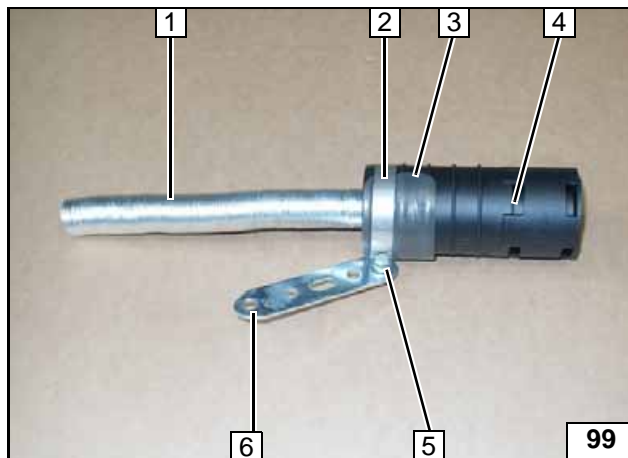

- 1 Combustion air pipe
- 2 51 mm dia. clamp
- 3 Self-adhesive foam strip
- 4 Silencer
- 5 M5x16 bolt, flanged nut
- 6 Perforated bracket



#### Premounting combustion air pipe and silencer

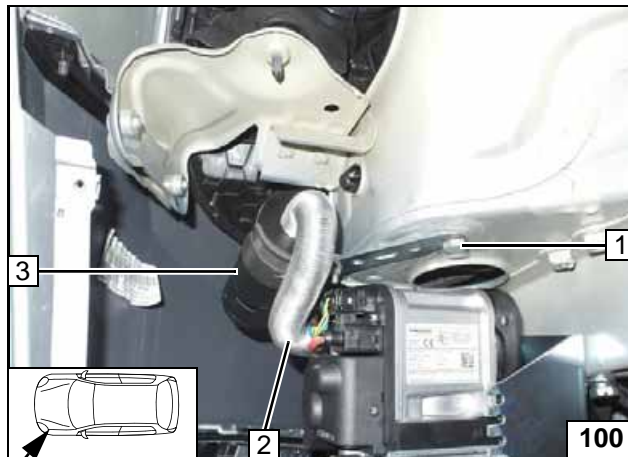

Remove original vehicle bolt at position 1 and discard.

- 1 M8x20 bolt, spring lockwasher, original vehicle thread
- 2 Combustion air pipe
- 3 Silencer



#### Installing silencer



**Fuel**



Open the vehicle's fuel tank cap, ventilate the tank and then re-close the tank lock.

Catch any fuel running off in an appropriate container.



Route fuel line and metering pump wiring harness so that they are protected against stone impact. Unless specified otherwise, always fasten using cable ties.

Provide rub protection for fuel line and wiring harness in areas where there are sharp edges.

The fuel line and wiring harness are routed to the metering pump as shown in the wiring harness routing diagram.

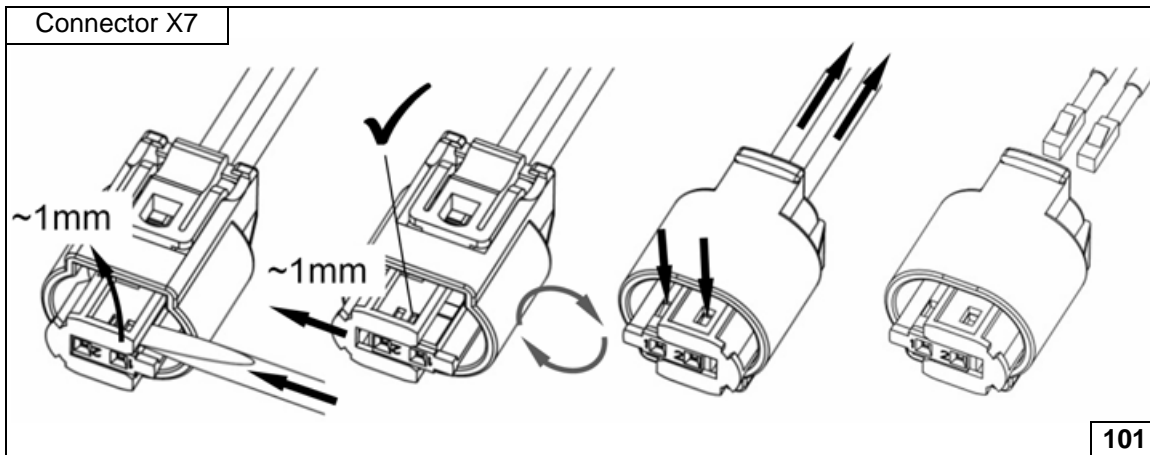

**Dismantling metering pump connector**

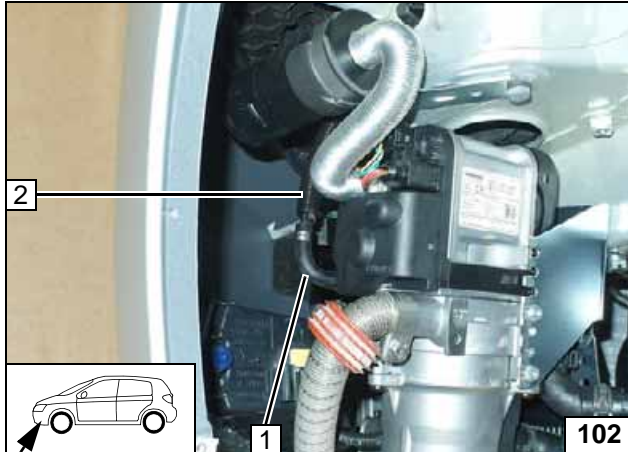

Pull fuel line and wiring harness of metering pump into 10mm dia. corrugated tube **2**. Route 10 mm dia. corrugated tube **2** in the engine compartment and fasten to combustion air pipe using cable ties.

- 1** 90° moulded hose, 10 mm dia. clamp [2x]



**Connecting heater**

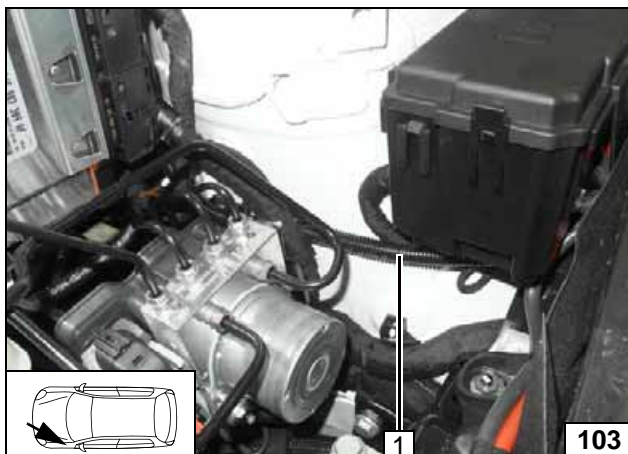

- 1** Fuel line and wiring harness of metering pump in 10mm dia. corrugated tube

**Routing lines**



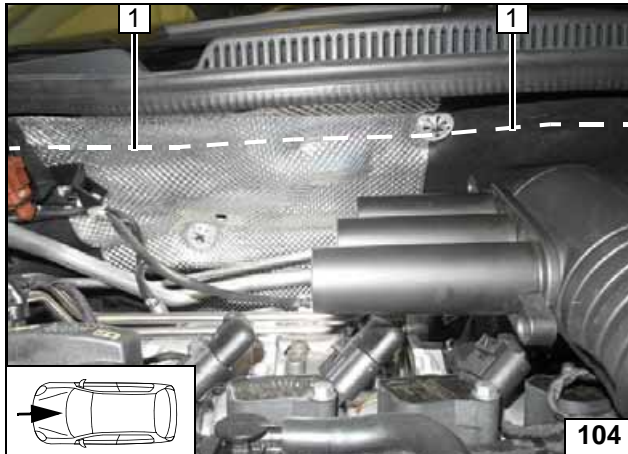

Install coolant reservoir partition wall. Route fuel line and wiring harness metering pump **1** behind the insulation mat at the marking to the right side of the vehicle.



**Routing lines**

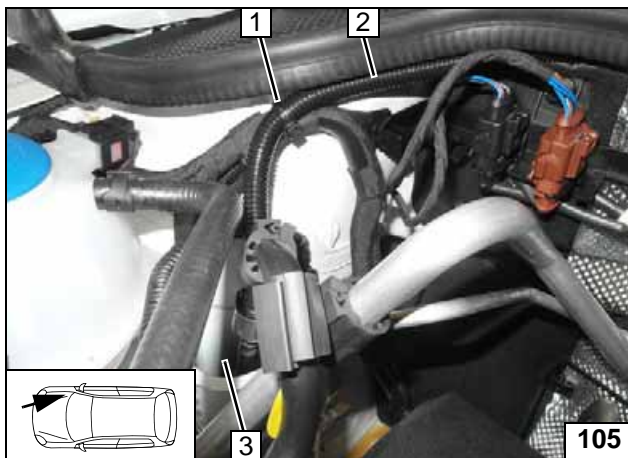

Route fuel line and wiring harness metering pump to the underbody through original vehicle line duct **3**.



**Routing lines**

- 1** Cable tie
- 2** Fuel line and wiring harness of metering pump in 10mm dia. corrugated tube



- 1** Fuel line, metering pump wiring harness
- 2** Original vehicle pass through for fuel lines

**Routing lines**

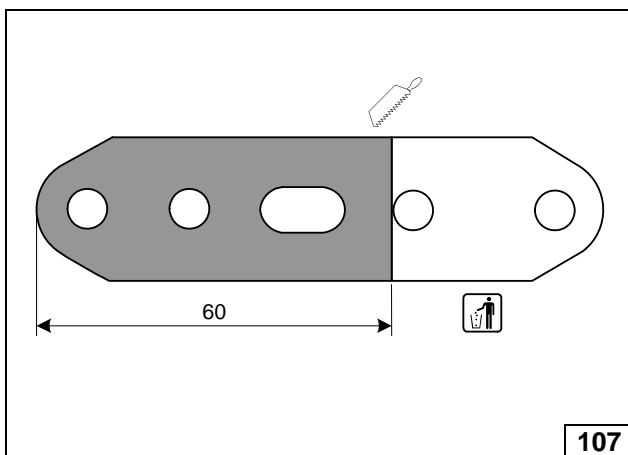

**Cutting perforated bracket to length**

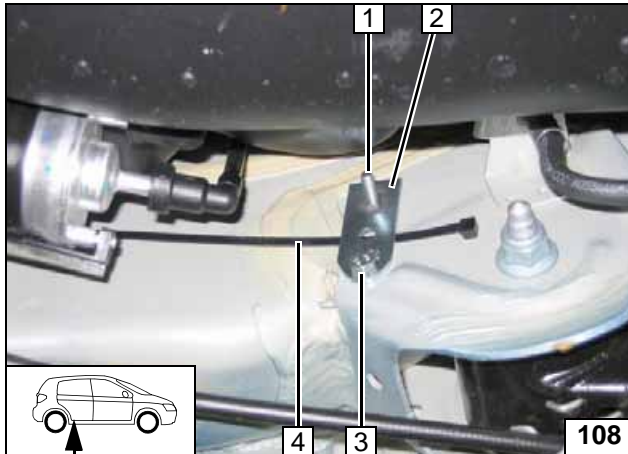

Insert cable tie 4 between perforated bracket 2 and body.

- 1 Pre-mount M6x25 bolt, pin lock
- 3 M6x20 bolt, flanged nut, original vehicle hole



**Installing perforated bracket**

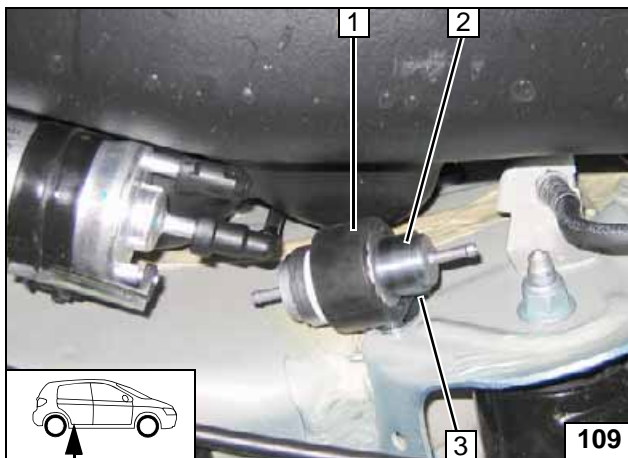

Fasten metering pump mount 1 with support angle bracket and flanged nut onto M6x25 bolt. Close cable tie 3 around metering pump mount 1 .

- 2 Metering pump



**Installing metering pump**

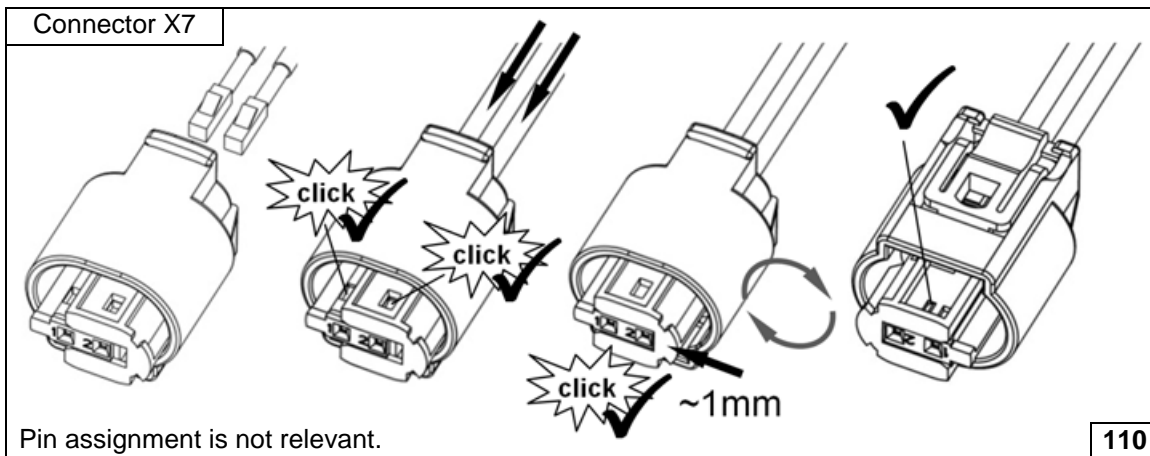

Connector X7

Pin assignment is not relevant.

110

**Completing metering pump connector**

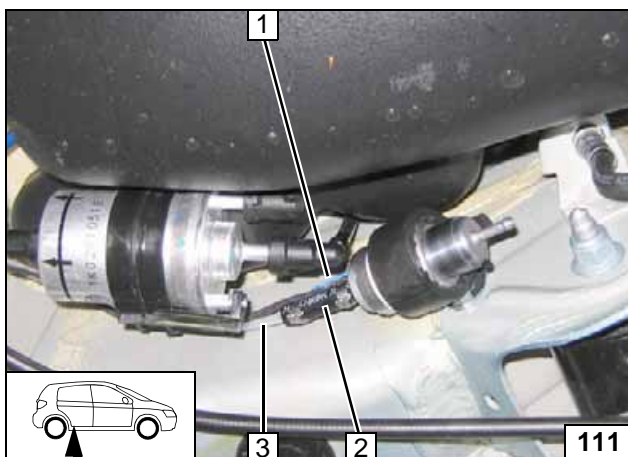

- 1 Metering pump wiring harness, connector X7 mounted
- 2 Hose section, 10 mm dia. clamp [2x]
- 3 Fuel line of heater



**Connecting metering pump**

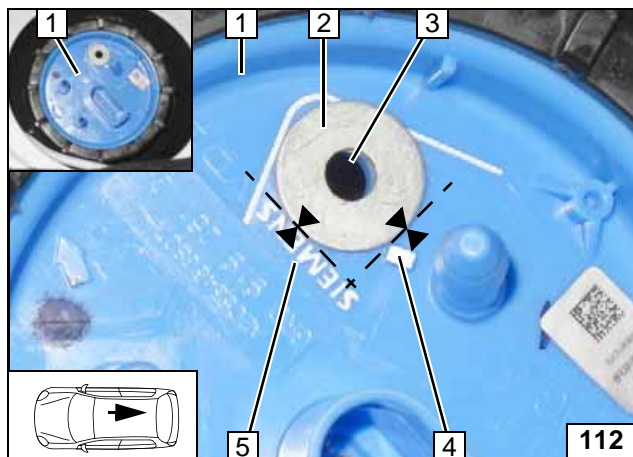

## Installing FuelFix for Petrol Vehicles

### Variante1

Work steps F1, F2 and F3.

- 1 Fuel tank sending unit
- 2 Position washer with outer dia.  $d_a = 21.6\text{mm}$  as template, copy hole pattern
- 3 Hole made with provided drill
- 4 Contact point with raised part
- 5 Contact point with writing (text may vary)



### Hole for FuelFix

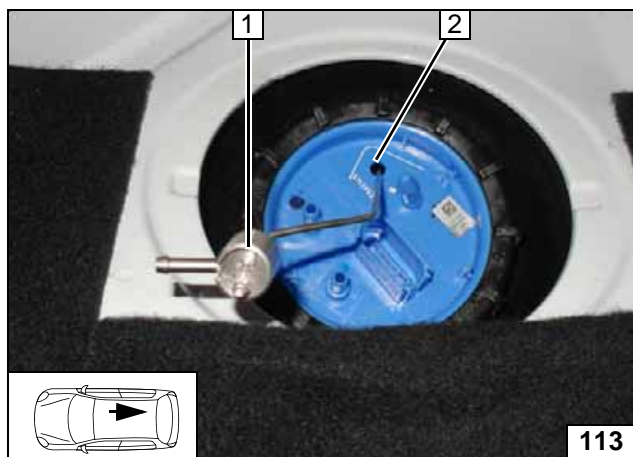

Work steps F4 and F5.

Bend FuelFix 1 according to template and cut to length.  
Insert into hole 2.



### Preparing and installing FuelFix

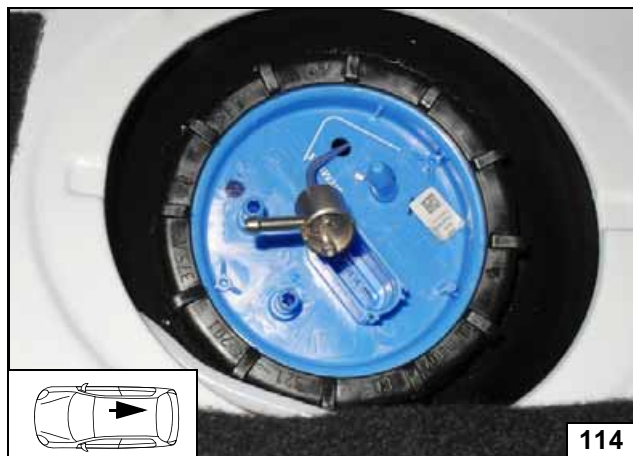

### Inserting FuelFix

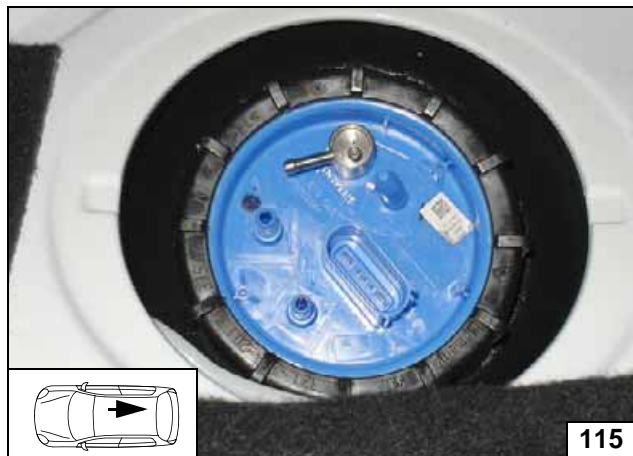

### Inserting FuelFix

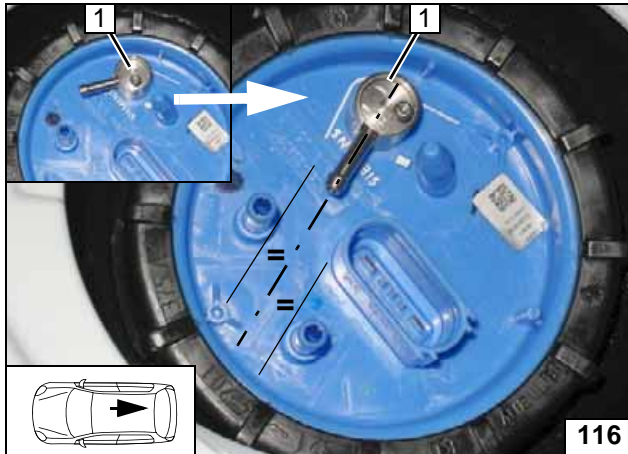

Work steps F5.3 and F5.4.

Align FuelFix 1 as shown.



**Aligning FuelFix**

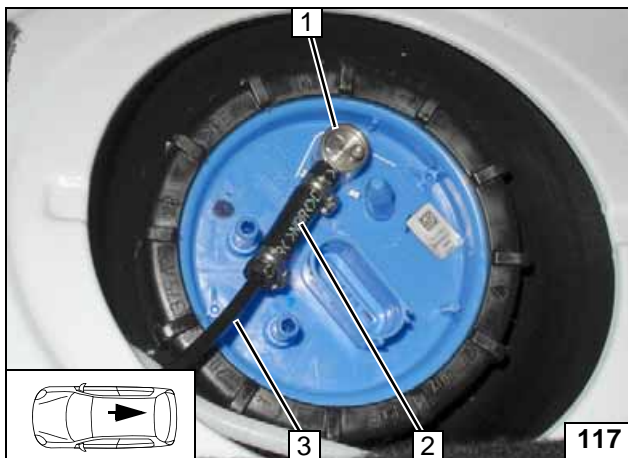

Work step F6.

- 1 FuelFix
- 2 Hose section, 10 mm dia. clamp [2x]
- 3 Fuel line



**Connecting fuel line**

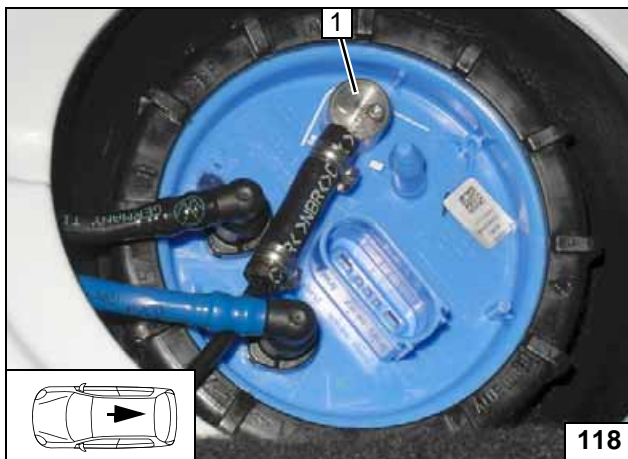

Install original vehicle fuel lines.  
Align and install FuelFix 1 as shown in the following figure.



**Installing FuelFix**

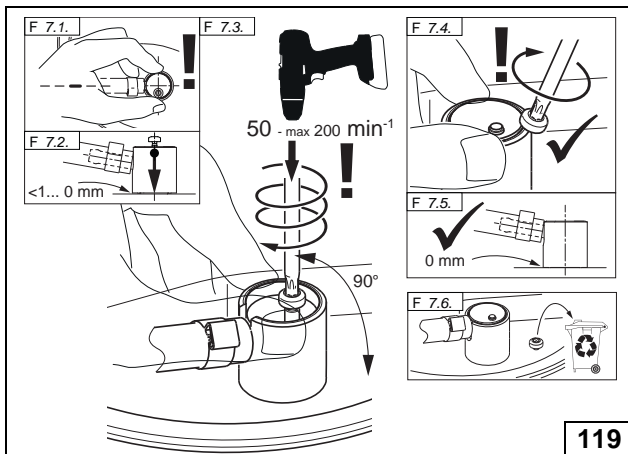

Work step F7.



**Installing FuelFix**



Work step F8.

Ensuring firm seating of FuelFix

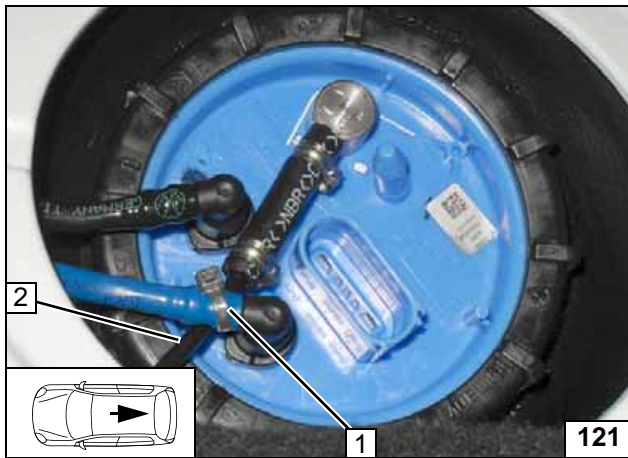

Work step F8.

- 1 Cable tie as tension relief
- 2 Fuel line of FuelFix

Securing fuel line

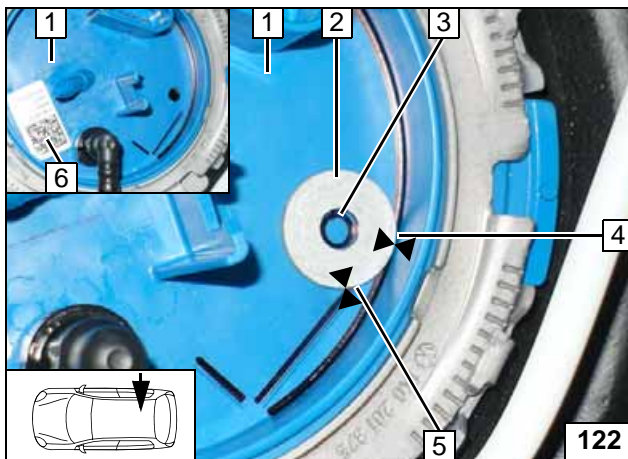

**Version 2**

Work steps F1, F2 and F3.

- 1 Fuel tank sending unit
- 2 Position washer with outer dia.  $d_a = 21.6\text{mm}$  as template, copy hole pattern
- 3 Hole made with provided drill
- 4 Contact point at rim of fuel tank sending unit
- 5 Contact point at end of raised part
- 6 Barcode label, moved



Hole for FuelFix

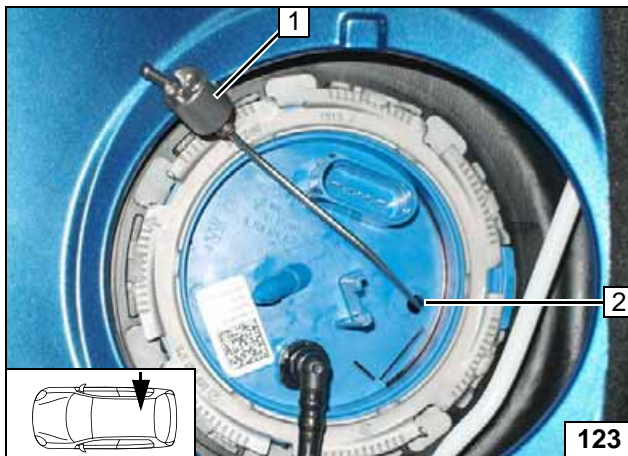

Work steps F4 and F5.

Bend FuelFix 1 according to template and cut to length. Insert into hole 2.



Preparing and installing FuelFix



124

Inserting FuelFix



125

Inserting FuelFix



126

Work steps F5.3 and F5.4.

Align FuelFix 1 as shown.



Aligning FuelFix

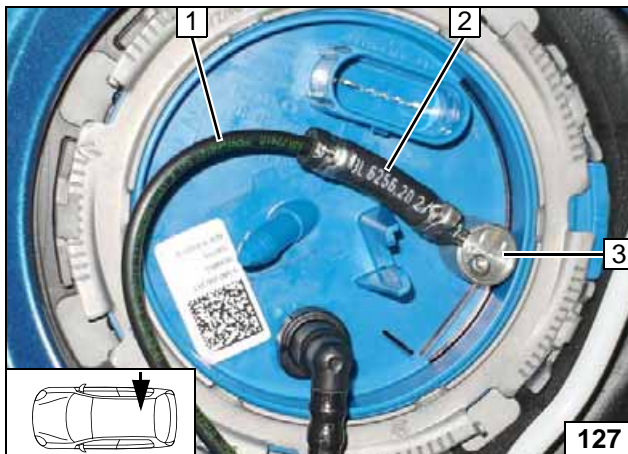

127

Work step F6.

- 1 Fuel line
- 2 Hose section, 10 mm dia. clamp [2x]
- 3 FuelFix

Connecting fuel line



Install original vehicle connector  
Align and install FuelFix 1 as shown in the following figure.



**Installing FuelFix**

Work step F7.



**Installing FuelFix**

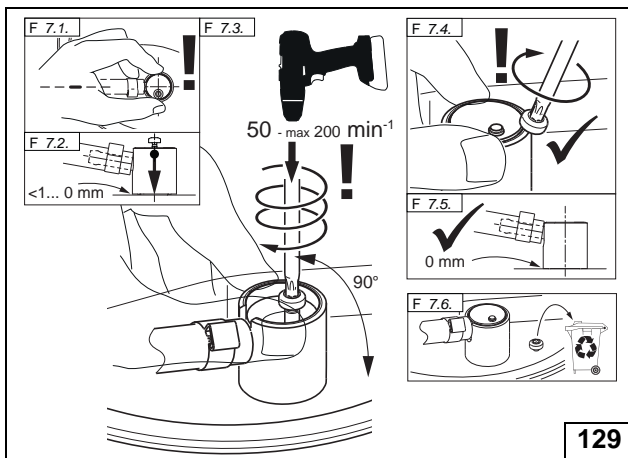

Work step F8.

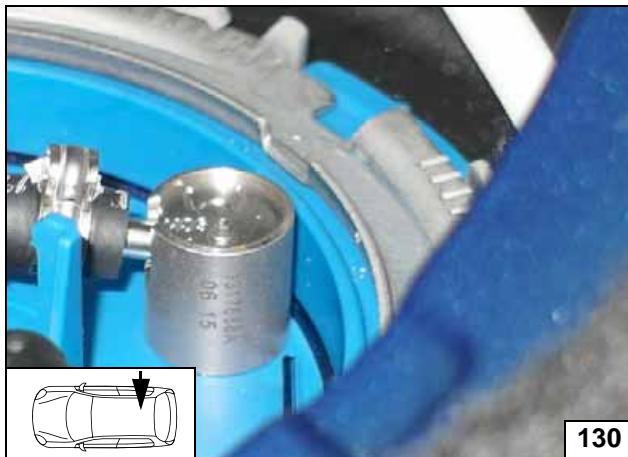

**Ensuring firm seating of FuelFix**

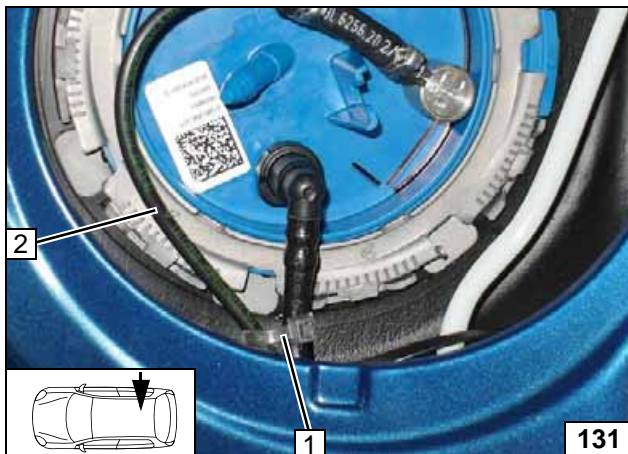

- 1 Cable tie as tension relief
- 2 Fuel line of FuelFix

**Securing fuel line**

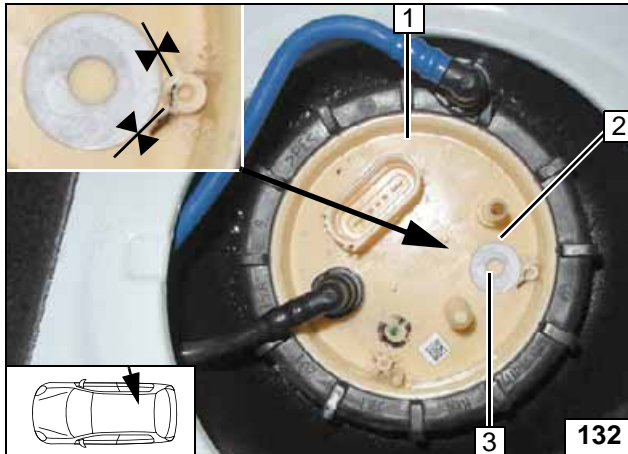
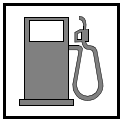

### Installing FuelFix for Diesel Vehicles

Work steps F1 and F2.

- 1 Fuel tank sending unit
- 2 Position washer with outer dia.  
 $d_a = 21.6\text{mm}$  as template against the raised parts.
- 3 Hole pattern



Fuel extraction

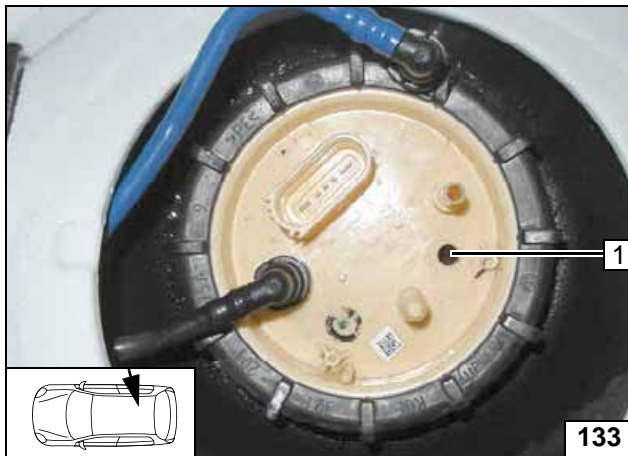

Work step F3.

- 1 Hole made with provided drill

Hole for FuelFix

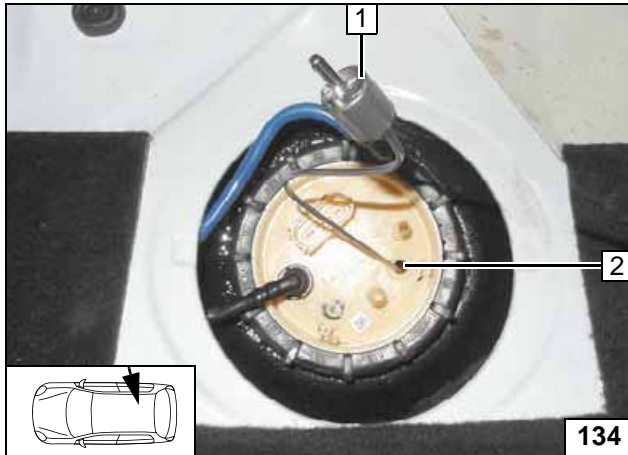

Work steps F4 and F5.

Bend FuelFix 1 according to template and cut to length.  
Insert into hole 2.



Inserting FuelFix

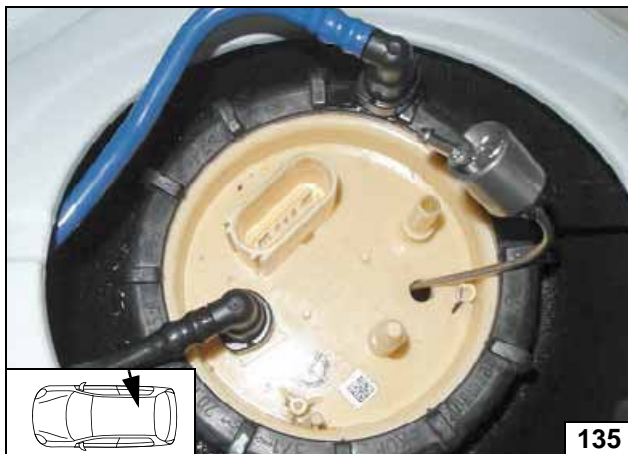

Inserting FuelFix



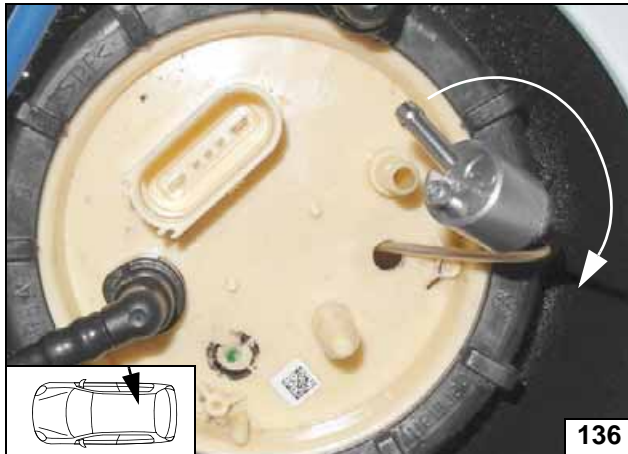

Inserting FuelFix

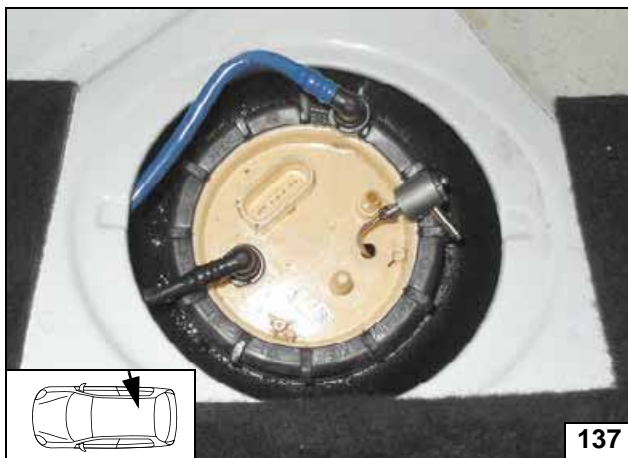

Inserting FuelFix

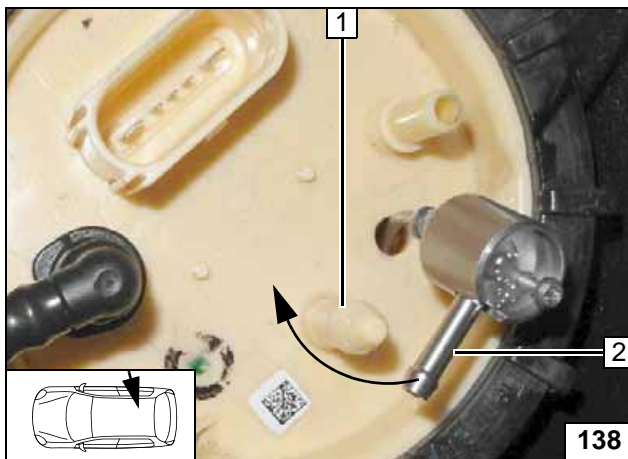

Move FuelFix connection piece 2 over closed stub 1.

Inserting FuelFix

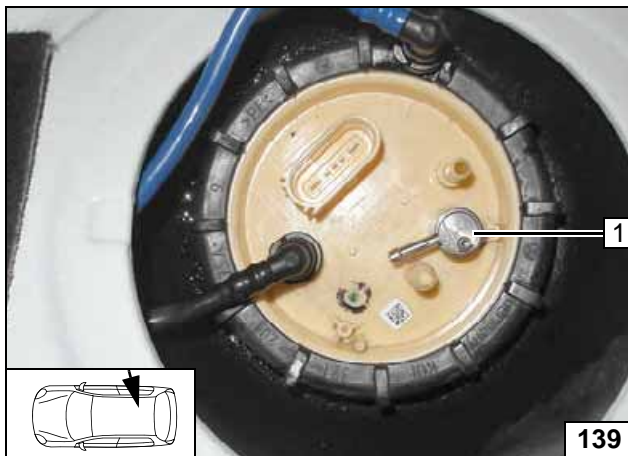

Work steps F5.3 and F5.4.

Turn FuelFix 1 in position as shown.



Positioning FuelFix

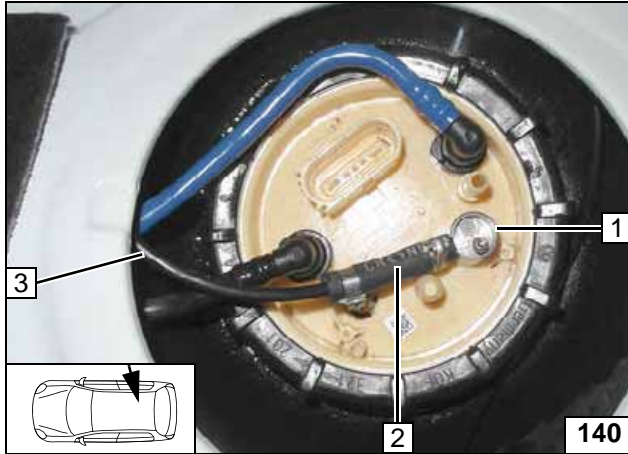
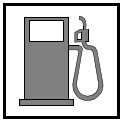

Work step F6.

- 1 FuelFix
- 2 Hose section, 10 mm dia. clamp [2x]
- 3 Fuel line



Connect-  
ing fuel line

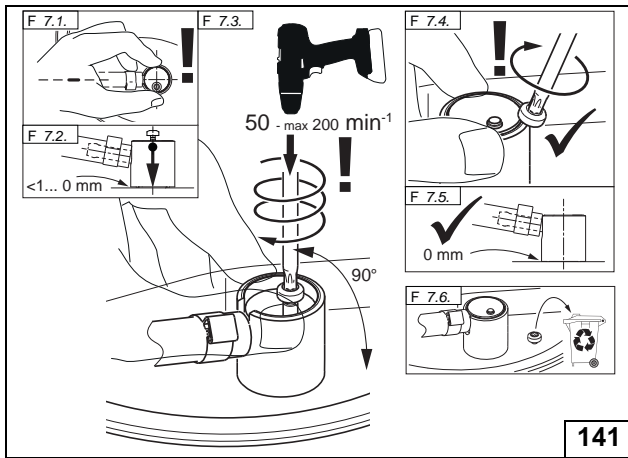

Work step F7.



Installing  
FuelFix

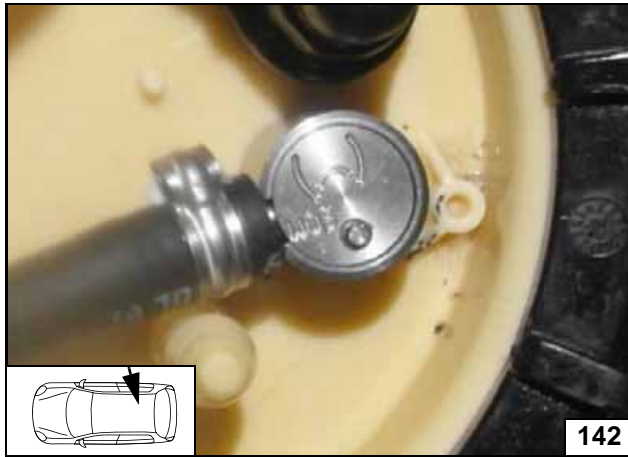

Work step F8.

Ensuring  
firm seating  
of FuelFix

- 1 FuelFix mounted
- 2 Fuel line of FuelFix
- 3 Cable tie as tension relief

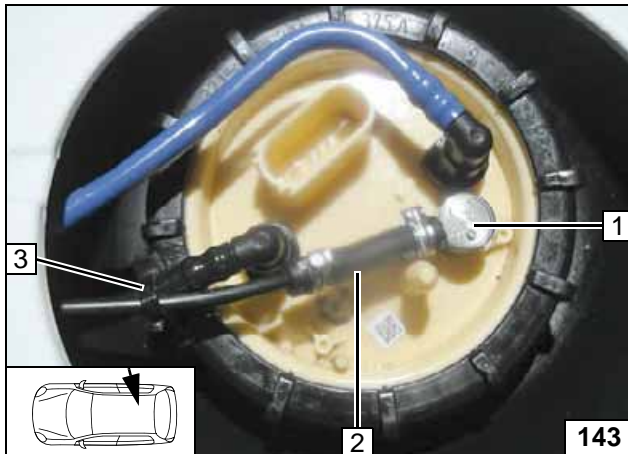

Securing  
fuel line

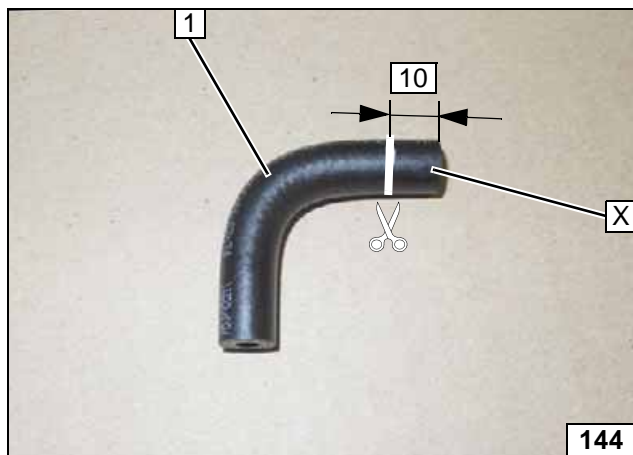

**All vehicles**

- 1 90° moulded hose

X =

**Cutting moulded hose to length**

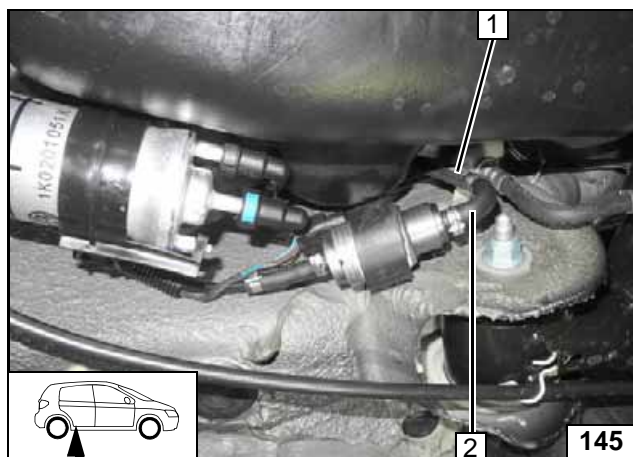

Check the position of the components; adjust if necessary. Check that they have freedom of movement.



- 1 Fuel line of FuelFix
- 2 90° moulded hose (shortened side), 10 mm dia. clamp [2x]

**Connecting metering pump**

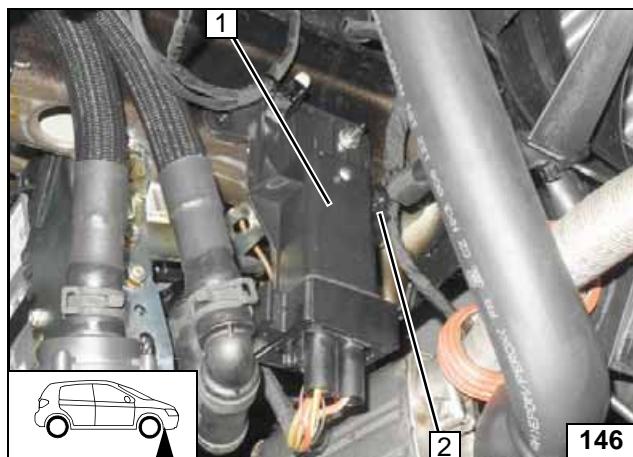
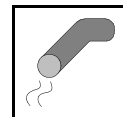

## Exhaust Part 2

All vehicles

Figure shows 1.0 MPI.

- 1 Original vehicle relay turned by 180°, reattach
- 2 Clip-type cable tie on relay, original vehicle wiring harness

Reattach-  
ing relay  
and wiring  
harness

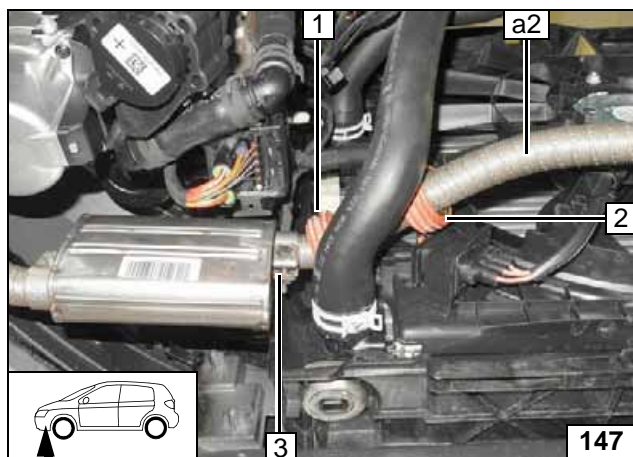

Petrol

1.0 MPi

- 1 Spacer bracket, align with coolant hose
- 2 Spacer bracket, align with connector
- 3 Hose clamp

Installing  
exhaust  
pipe a2

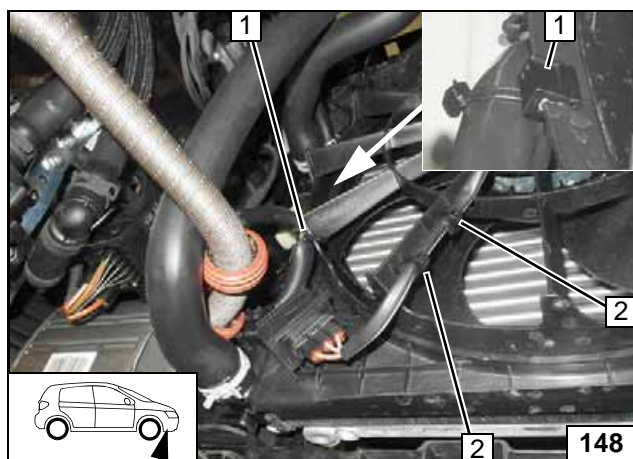

- 1 Clip-type cable tie
- 2 Cable tie [2x]

Attaching  
wiring har-  
ness

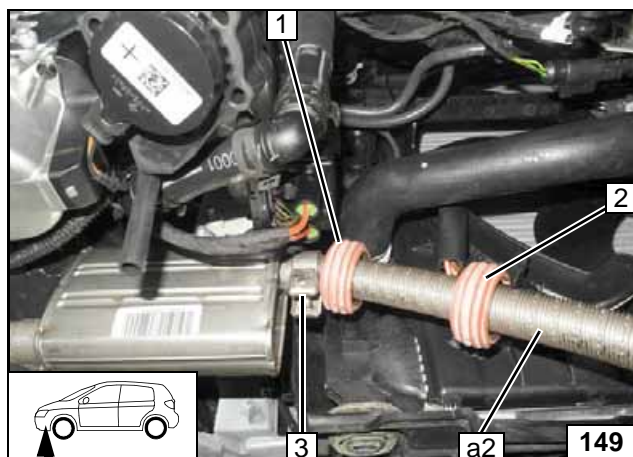

1.2 TSi

- 1 Spacer bracket, align with coolant hose
- 2 Spacer bracket, align with connector
- 3 Hose clamp

Installing  
exhaust  
pipe a2



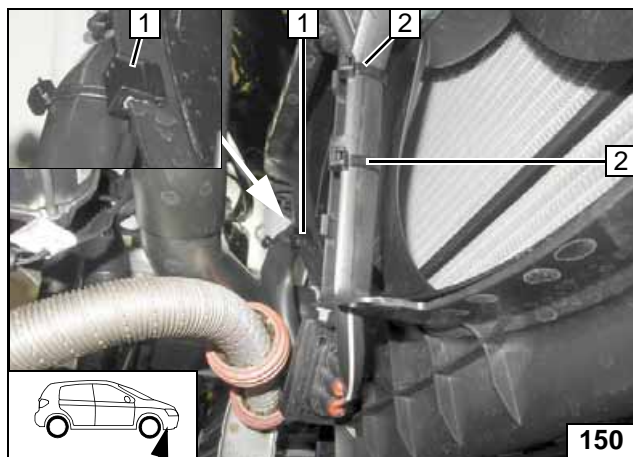
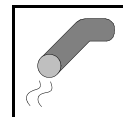

- 1 Clip-type cable tie
- 2 Cable tie [2x]

Attaching wiring harness

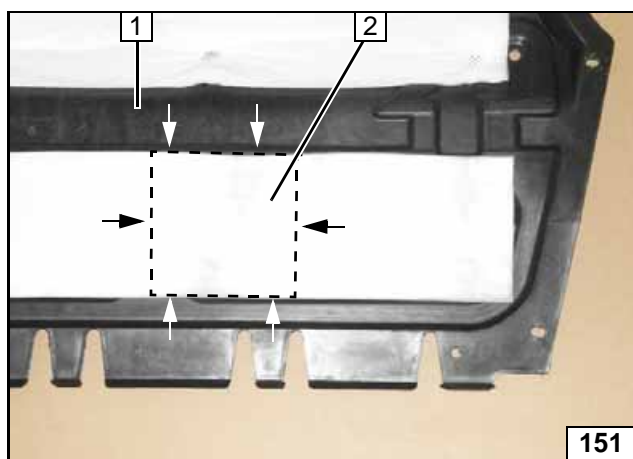

**All petrol vehicles**

Remove marked area of insulation mat 2 (if present).

- 1 Underride protection



Removing insulation mat

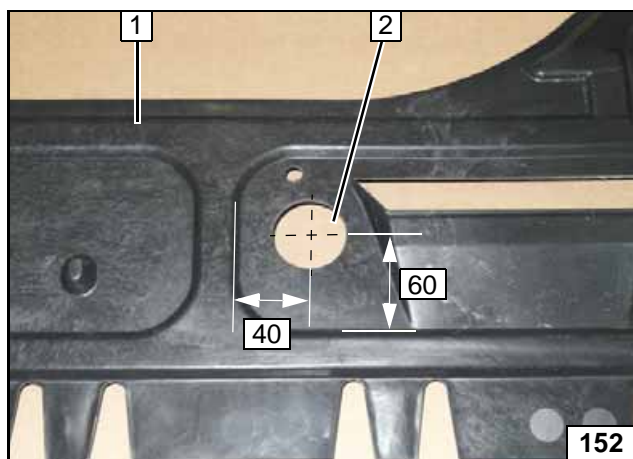

- 1 Underride protection
- 2 Hole (as per work step 1 of the installation instructions)



Hole in underride protection

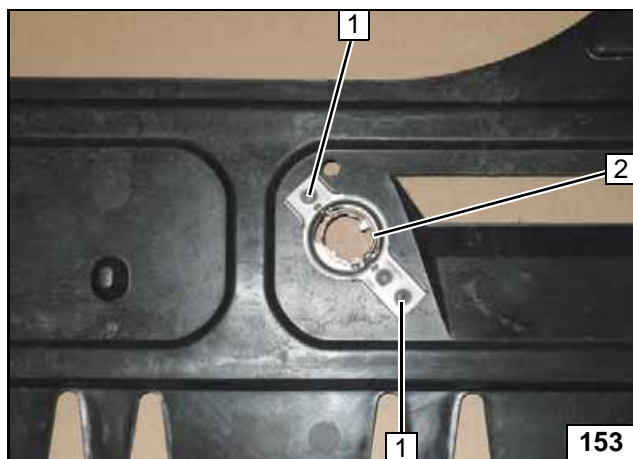

Place exhaust end fastener 2 as per work step 3 of the installation instructions and copy hole pattern 1 [2x].



Copying hole pattern

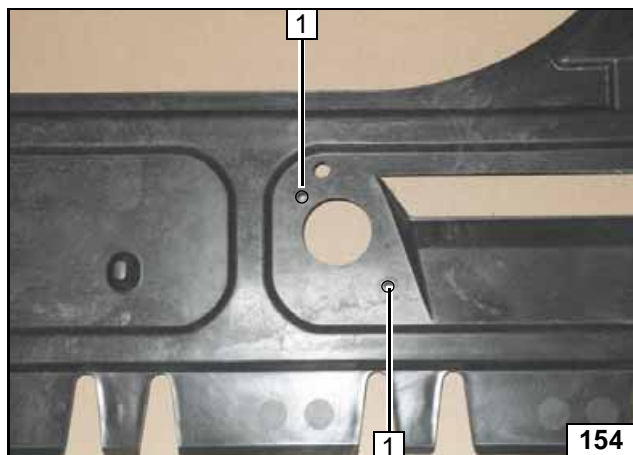
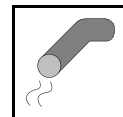

Hole 1 [2x] as per work step 4 of the installation instructions.



Holes in under-  
ride protection

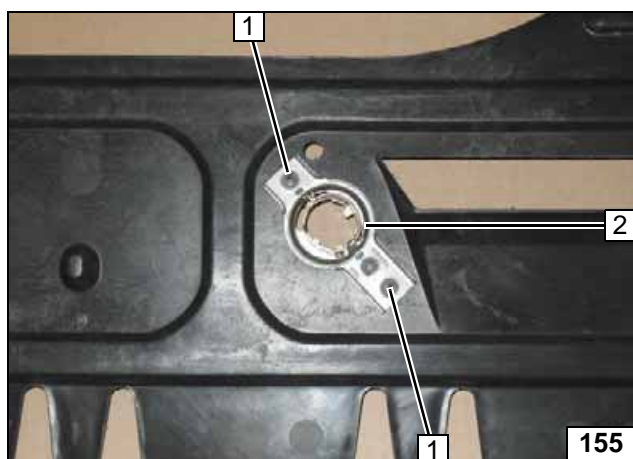

- 1 5x13 self-tapping screw [2x] as per work step 5 of the installation instructions
- 2 Exhaust end fastener



Installing ex-  
haust end  
fastener

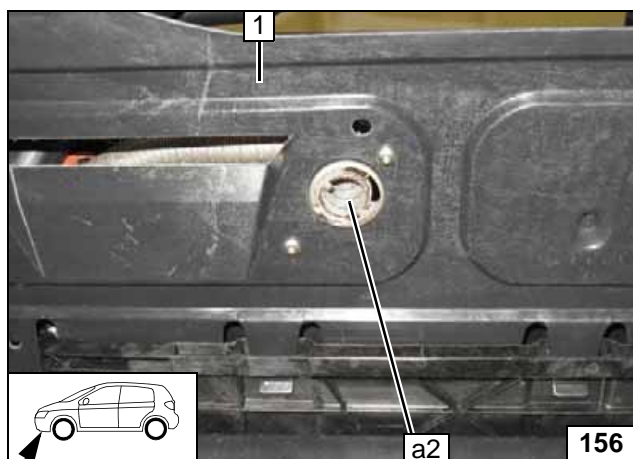

Install under-  
ride protection 1.  
Install exhaust pipe a2 as per work step 6  
- 8 of the installation instructions.



Installing  
exhaust  
pipe a2

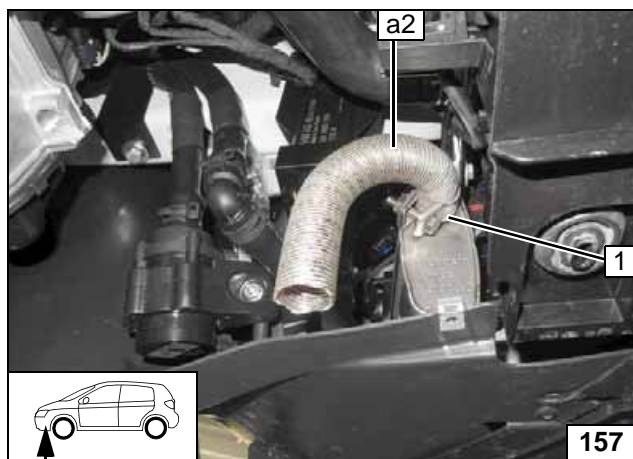

Diesel

- 1 Hose clamp



Installing  
exhaust  
pipe a2

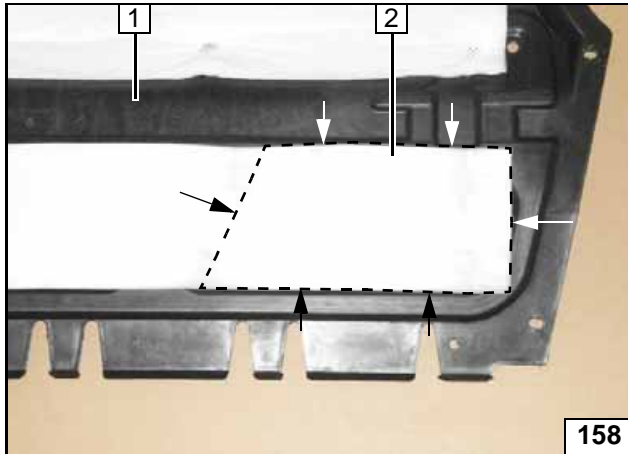
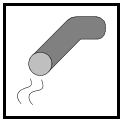

Remove marked area of insulation mat **2**.



**1** Underride protection

Removing insulation mat

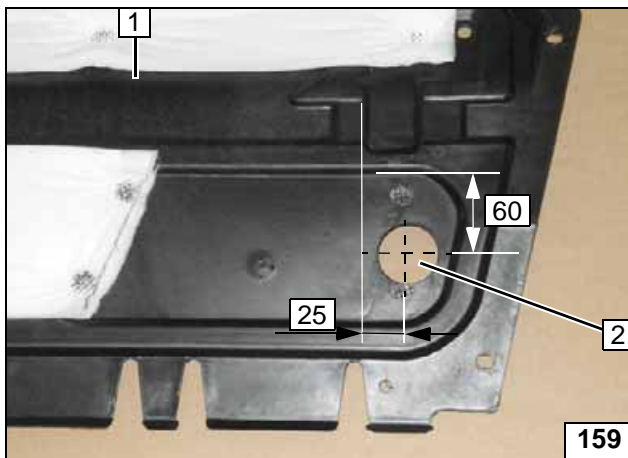

**1** Underride protection  
**2** Hole (as per work step 1 of the installation instructions)



Hole in underride protection

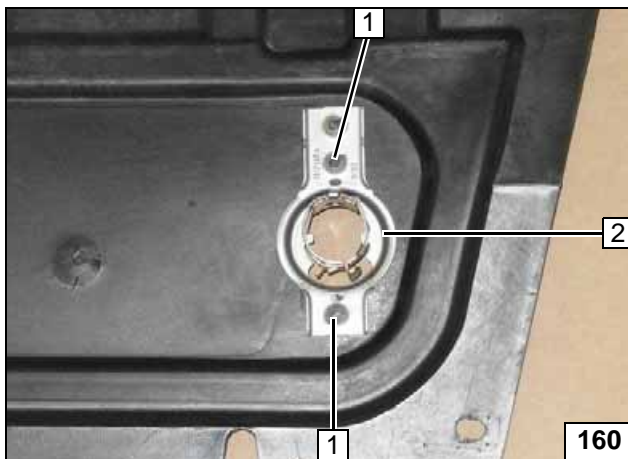

Position exhaust end fastener **2** as per work step 3 of the installation instructions and copy hole pattern **1** [2x].



Copying hole pattern

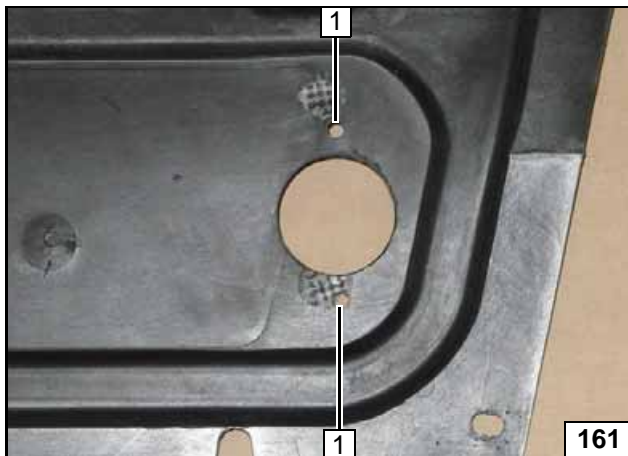

Hole **1** [2x] as per work step 4 of the installation instructions.



Holes in underride protection

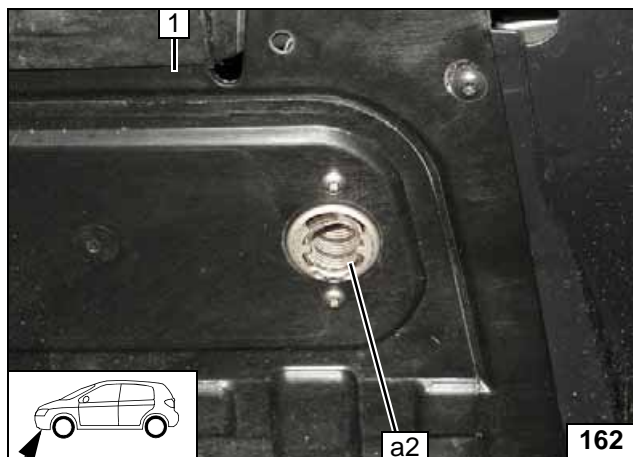
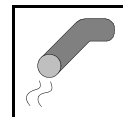

Install underide protection **1**. Install exhaust pipe **a2** as per work step 6 - 8 of the installation instructions.



**Installing  
exhaust  
pipe a2**



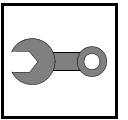

**Final Work**



Reassemble the components in reverse order. Check all hoses, clamps and all electrical connections for firm seating. Insulate loose wire ends and tie back. Only use manufacturer-approved coolant. Spray the heater components with anti-corrosion wax (Tectyl 100K).

- Connect the battery.
- Fill and bleed the coolant circuit according to the vehicle manufacturer's specifications.
- Program MultiControl CAR, teach Telearstart transmitter.
- Make settings on A/C control panel according to the 'Operating Instructions for End Customer'.
- Place the 'Switch off parking heater before refuelling' caution label near the filler neck.
- For initial startup and function check, please see installation instructions.

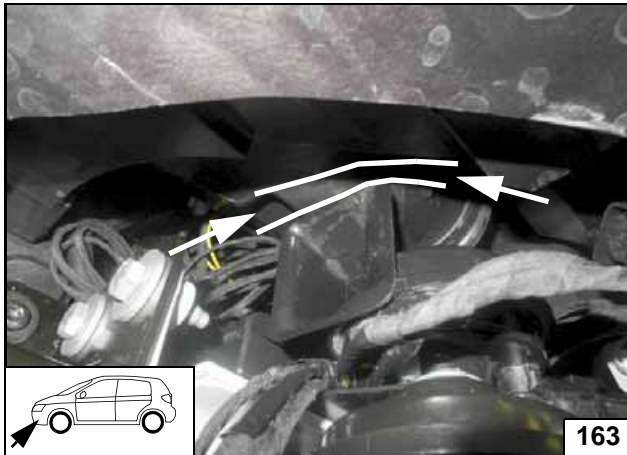

After headlight installation check the distance to the upper horn and after bumper trim installation check the distance between the wiring harnesses for horns, cornering light as well as front fog lights and the exhaust system, correct if necessary.

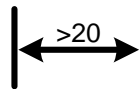

**Distance check**



Figure shows 1.0 MPI.

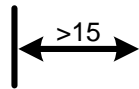

**Aligning silencer**



Webasto Thermo & Comfort SE  
 Postfach 1410  
 82199 Gilching  
 Germany  
 Internet: [www.webasto.com](http://www.webasto.com)  
 Technical Extranet:  
<http://dealers.webasto.com>



FuelFix Template for Petrol Vehicles

Top view

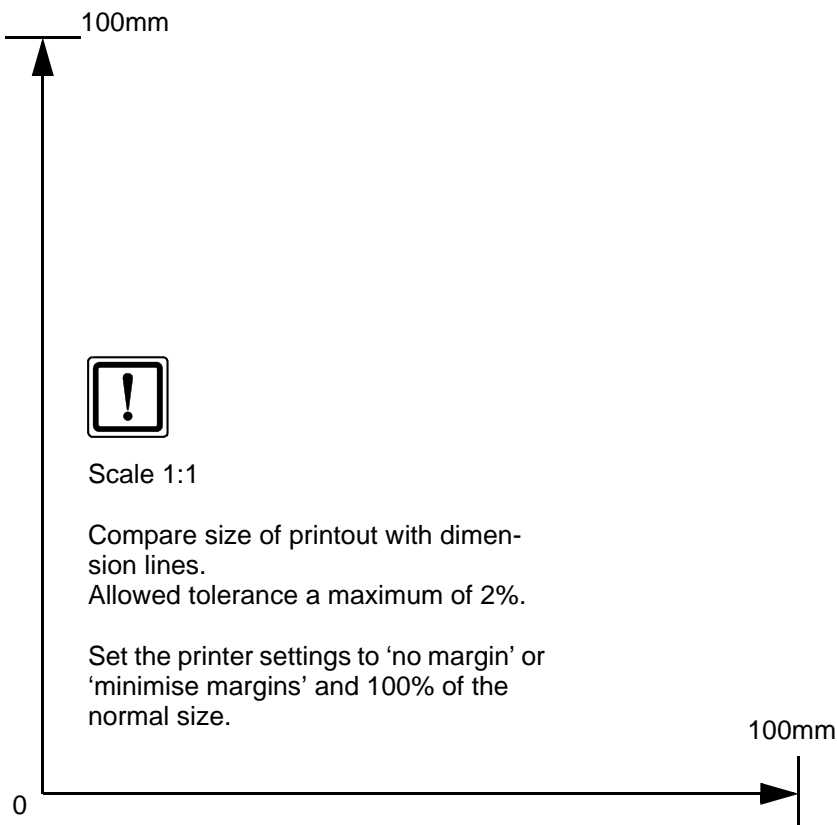
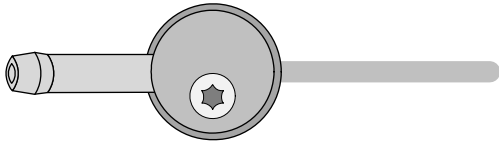

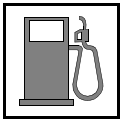

FuelFix Template for Diesel Vehicles

Top view

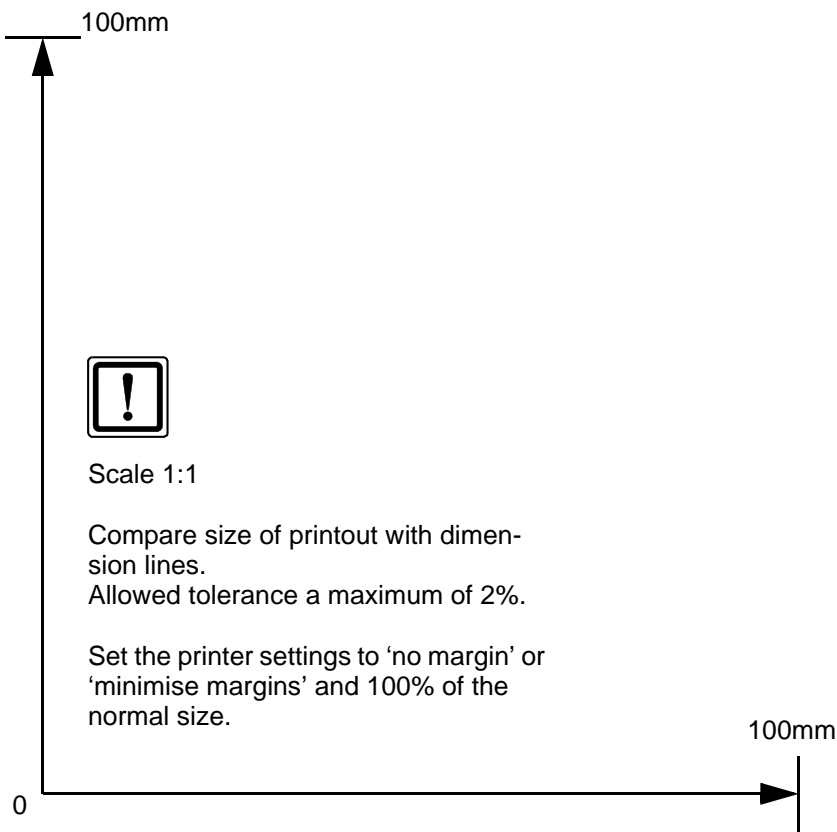
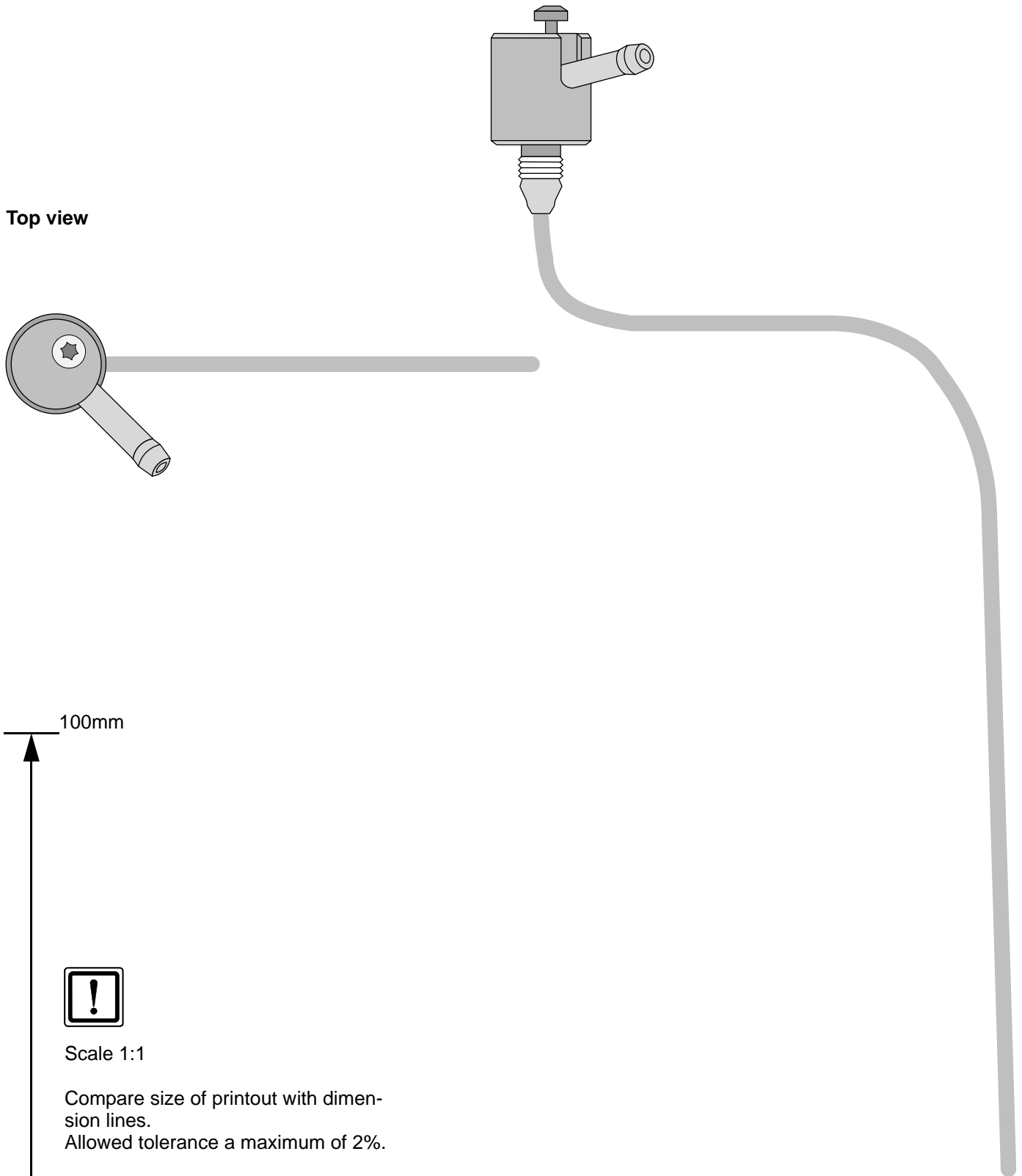

Scale 1:1

Compare size of printout with dimension lines.  
Allowed tolerance a maximum of 2%.

Set the printer settings to 'no margin' or 'minimise margins' and 100% of the normal size.

## Operating Instructions for Manual Air-Conditioning

Please remove page and add to the vehicle operating instructions.

**Note:**

We recommend matching the heating time to the driving time.

Heating time = driving time

**Example:**

For a driving time of approx. 20 min. (in one direction), we recommend not exceeding a switch-on time of 20 min.

Passenger compartment monitoring, if installed, must be deactivated in addition to the vehicle settings for the heating operation.

For instructions on deactivation, please refer to the operating instructions of the vehicle.

Before parking the vehicle, make the following settings:

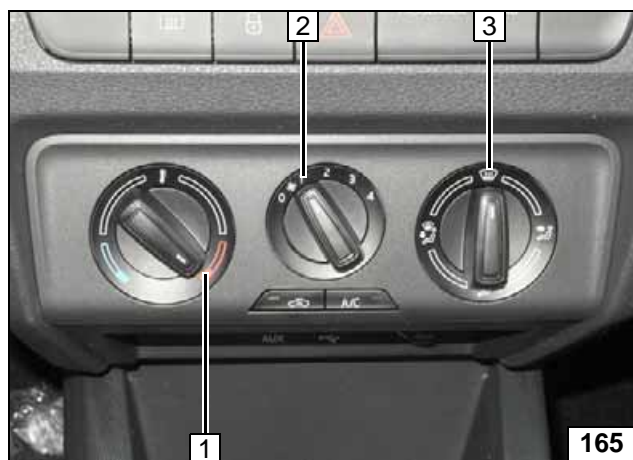

- 1 Set temperature to 'max.'
- 2 Set fan to level '1', or max. '2'
- 3 Air outlet to windscreen



A/C control panel

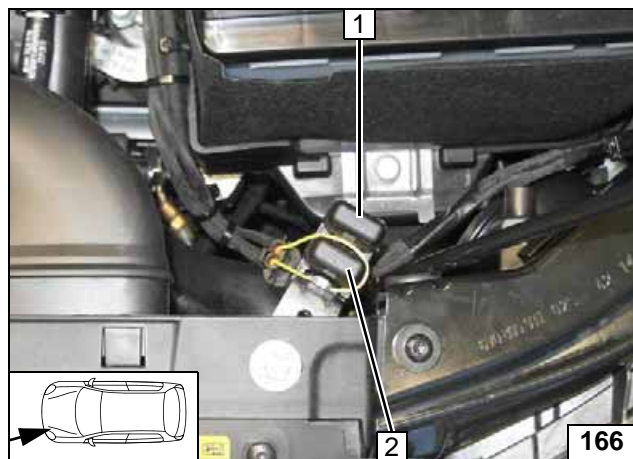

- 1 20A heater fuse F1
- 2 30A passenger compartment main fuse F2

Engine compartment fuses

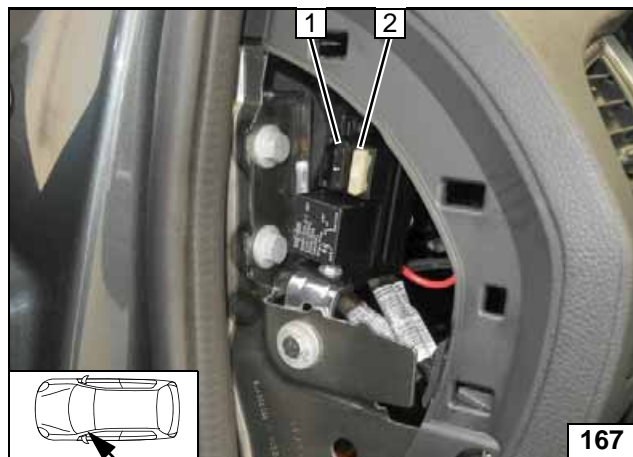

- 1 1A heater control fuse F3
- 2 25A fan fuse F4

Passenger compartment fuses



## Operating Instructions for Automatic Air-Conditioning

Please remove page and add to the vehicle operating instructions.

**Note:**

We recommend matching the heating time to the driving time.

Heating time = driving time

**Example:**

For a driving time of approx. 20 min. (in one direction), we recommend not exceeding a switch-on time of 20 min.

Passenger compartment monitoring, if installed, must be deactivated in addition to the vehicle settings for the heating operation.

For instructions on deactivation, please refer to the operating instructions of the vehicle.

Before parking the vehicle, make the following settings:

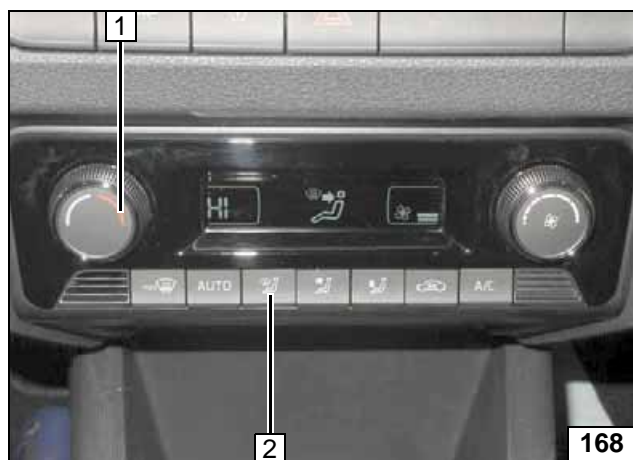

- 1 Set temperature to 'HI'
- 2 Air outlet to windscreen

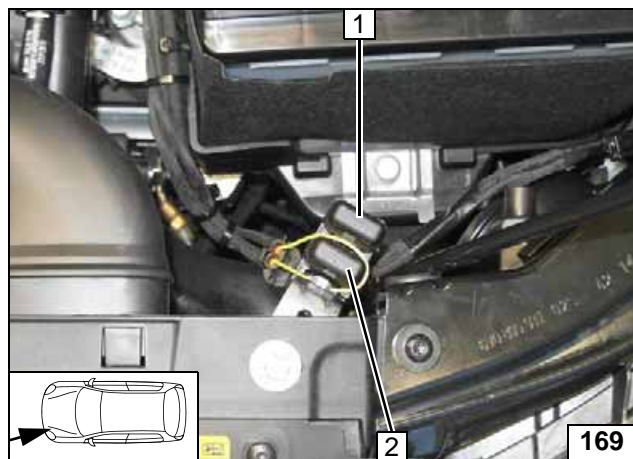

- 1 20A heater fuse F1
- 2 30A passenger compartment main fuse F2

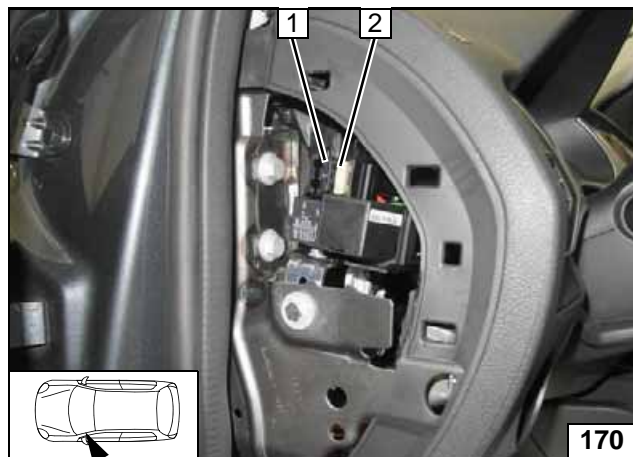

- 1 1A heater control fuse F3
- 2 25A fan fuse F4



A/C control panel

Engine compartment fuses

Passenger compartment fuses

