



Water Heater

Thermo Top Evo Parking Heater



With FuelFix

Installation Documentation Ford Focus / C-Max / Grand C-Max

Validity

Manufacturer	Model	Type	EG BE No. / ABE
Ford	Focus	DYB	e13 * 2007 / 46 * 1138 * ...

Motorisation	Fuel	Transmission type	Output in kW	Displacement in cm ³	Engine code
1.0 EcoBoost	Petrol	SG	74	998	M2DA
1.0 EcoBoost	Petrol	SG	74	998	M2DC
1.0 EcoBoost	Petrol	SG	92	998	M1DA
1.0 EcoBoost	Petrol	SG	92	998	M1DD
1.5 EcoBoost	Petrol	SG	110	1498	M9DB
1.5 EcoBoost	Petrol	SG	134	1498	M9DB

SG = manual transmission

Manufacturer	Model	Type	EG BE No. / ABE
Ford	C-Max	DXA	e13 * 2007 / 46 * 1103 * ...
Ford	Grand C-Max	DXA	e13 * 2007 / 46 * 1103 * ...

Motorisation	Fuel	Transmission type	Output in kW	Displacement in cm ³	Engine code
1.0 EcoBoost	Petrol	SG	92	998	M1DA
1.0 EcoBoost	Petrol	SG	92	998	M1DD

SG = manual transmission

From model year 2015

Left-hand drive vehicle

Verified equipment variants: Manual air-conditioning
Automatic air-conditioning
Automatic Start-Stop system

Not verified: Passenger compartment monitoring

Total installation time: approx. 9.5 hours

Table of Contents

Validity	1	Automatic A/C Control	12
Necessary Components	2	Focus Heater Control	12
Installation Overview	2	C-Max / Grand C-Max Heater Control	14
Information on Total Installation Time	2	Preparing Installation Location	16
Information on Operating and Installation Instructions	3	Preparing Heater	16
Information on Validity	4	Installing Heater	18
Technical Information	4	Fuel	20
Explanatory Notes on Document	4	Installing FuelFix	21
Preliminary Work	5	Combustion Air	26
Heater Installation Location	5	Exhaust Gas	27
Preparing Electrical System	6	Coolant Circuit	29
Wiring Harness Routing for Focus	7	Final Work	35
Wiring Harness Routing for C-Max / Grand C-Max	8	FuelFix Template	36
Manual Air-Conditioning Fan Controller	9	Operating Instructions for Focus with Man. A/C	37
Fan Controller for Focus	10	Operating Instructions for C-Max / Grand C-Max with Man. A/C	38
Fan Controller for C-Max / Grand C-Max	11		

Necessary Components

- Basic delivery scope of Thermo Top Evo based on price list
- Installation kit with FuelFix Ford Focus / C-Max / Grand C-Max 2015 Petrol: **1324046A**
- To be ordered additionally in case of automatic air-conditioning either:
Installation kit 'Webasto Standard' A/C control for Ford Focus / C-Max / Grand C-Max: **1324049_**
or
Installation kit 'Webasto Comfort' A/C control for Ford Focus / C-Max / Grand C-Max: **1324107_**
- Heater control in accordance with price list and upon consultation with end customer
- In case of Telestart, indicator lamp in accordance with price list and in consultation with end customer
- In case of MultiControl CAR installation: Timer cable extension: **1319724_**
- In case of MultiControl CAR installation: MultiControl installation frame: **9030077_**

Installation instructions:

- Arrange for the vehicle to be delivered with the tank only about ¼ full.
- The installation location of the push button in case of Telestart or ThermoCall should be confirmed with the end customer.
- Depending on the space required and the vehicle manufacturer's instructions, we recommend the use of a vehicle battery with a higher electrical capacity.

Installation Overview

Legend:

1. Heater
2. Engine compartment fuse holder
3. Passenger compartment relay and fuse holder
4. Circulating pump
5. MultControl CAR
6. Metering pump
7. FuelFix

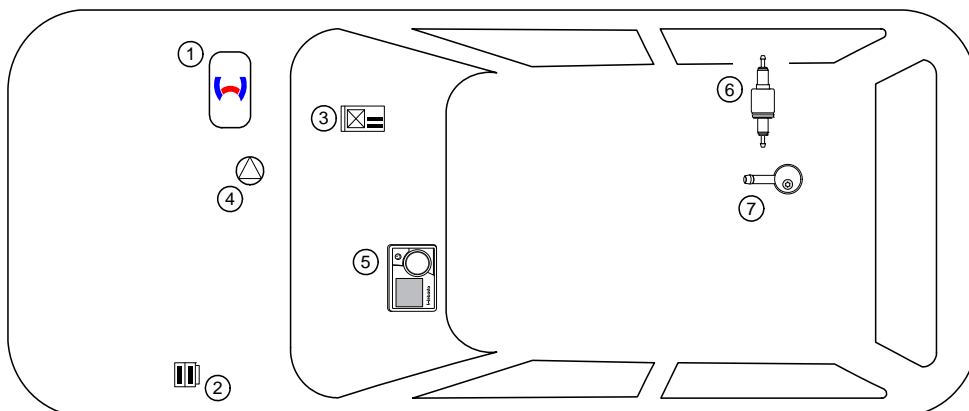

Information on Total Installation Time

The total installation time includes the time needed for mounting and demounting the vehicle-specific components, the heater specific installation time and all other times required for the system integration and initial start-up of the heater. The total installation time may vary for vehicle equipment other than provided.

Information on Operating and Installation Instructions

1 Important information (not complete)

1.1 Installation and repair



The improper installation or repair of Webasto heating and cooling systems can cause fire or the leakage of deadly carbon monoxide, leading to serious injury or death.



To install and repair Webasto heating and cooling systems you need to have completed a special company training course and have the appropriate technical documentation, special tools and special equipment.



Installation and repair may ONLY be carried out by persons trained and certified in a Webasto training course. NEVER try to install or repair Webasto heating or cooling systems if you have not completed a Webasto training course, you do not have the necessary technical skills and you do not have the technical documentation, tools and equipment available to ensure that you can complete the installation and repair work properly.

Only use genuine Webasto parts. See the Webasto air and water heaters accessories catalogue for this purpose.

1.2 Operation

To ensure safe operation, we recommend having the heater checked every two years by an authorised Webasto dealer, especially when used over a long period and/or under extreme environmental conditions.

Do not operate the heater in closed rooms due to the danger of poisoning and suffocation.

Always switch off the heater before refuelling.

The heater may only be used with the prescribed fuel diesel (DIN EN 590) or petrol (DIN EN 228).

The heater may not be cleaned with a high-pressure cleaner.

1.3 Please note

ALWAYS follow all Webasto installation and operating instructions and observe all warnings.

To become familiar with and understand all functions and properties of the heater, the operating instructions must be read carefully and observed at all times.

For proper, safe installation and repair work, the installation instructions with all warnings and safety information must be carefully read and observed at all times. Please always contact a workshop authorised by Webasto for all installation and repair work.

Important

Webasto shall assume no liability for defects, damage and injuries resulting from a failure to observe the installation, repair and operating instructions of the information contained in them.

This liability exclusion particularly applies to improper installations and repairs, installations and repairs by untrained persons or in the case of a failure to use genuine spare parts.

The liability due to culpable disregard to life, limb or health and due to damage or injuries caused by a wilful or reckless breach of duty remain unaffected, as does the obligatory product liability.

Installation should be carried out according to the general, standard rules of technology. Unless specified otherwise, fasten hoses, lines and wiring harnesses to original vehicle lines and wiring harnesses using cable ties. Insulate loose wire ends and tie back. Connectors on electronic components have to audibly click into place during installation.

Sharp edges should be fitted with rub protection. Spray unfinished body areas, e.g. drilled holes, with anti-corrosion wax (Tectyl 100K).

Observe the instructions and guidelines of the respective vehicle manufacturer for demounting and mounting vehicle specific components!

The initial startup is to be executed with the Webasto Thermo Test Diagnosis.

When installing a programmable control module (e.g. a PWM Gateway), the corresponding settings must be checked or adjusted.

2 Statutory regulations governing installation

Guidelines	Thermo Top Evo
Heating Directive ECE R122	E1 00 0258
EMC Directive ECE R10	E1 04 5627

Note

The regulations of these guidelines are binding in the scope of the Directive 70/156/EEC and/or 2007/46/EC (for new vehicle models from 29/04/2009) and should also be observed in countries in which there are no special regulations.

Important

Failure to follow the installation instructions will result in the invalidation of the type approval for the heater and therefore invalidation of the general **homologation of the vehicle**.

Note

The heater is licensed in accordance with paragraph 19, section 3, No. 2b of the StVZO (German Road Traffic Licensing Authority).

2.1 Excerpt from ECE regulation 122 (heating system) paragraph 5 for the installation of the heater

Beginning of excerpt.

ANNEX VII

REQUIREMENTS FOR COMBUSTION HEATERS AND THEIR INSTALLATION

1. GENERAL REQUIREMENTS

1.7.1. A clearly visible tell-tale in the operator's field of view shall inform when the combustion heater is switched on or off.

2. VEHICLE INSTALLATION REQUIREMENTS

2.1. Scope

2.1.1. Subject to paragraph 2.1.2, combustion heaters shall be installed according to the requirements of this Annex.

2.1.2. Vehicles of category O having liquid fuel heaters are deemed to comply with the requirements of this Annex.

2.2. Positioning of heater

2.2.1. Body sections and any other components in the vicinity of the heater must be protected from excessive heat and the possibility of fuel or oil contamination.

2.2.2. The combustion heater shall not constitute a risk of fire, even in the case of overheating. This requirement shall be deemed to be fulfilled if the installation ensures an adequate distance to all parts and suitable ventilation, by the use of fire resistant materials or by the use of heat shields.

2.2.3. In the case of M2 and M3 vehicles, the heater must not be positioned in the passenger compartment. However, an installation in an effectively sealed envelope which also complies with the conditions in paragraph 2.2.2 may be used.

2.2.4. The label referred to in paragraph 1.4 or a duplicate, must be positioned so that it can be easily read when the heater is installed in the vehicle.

2.2.5. Every reasonable precaution should be taken in positioning the heater to minimise the risk of injury and damage to personal property.

2.3. Fuel supply

2.3.1. The fuel filler must not be situated in the passenger compartment and must be provided with an effective cap to prevent fuel spillage.

2.3.2. In the case of liquid fuel heaters, where a supply separate to that of the vehicle is provided, the type of fuel and its filler point must be clearly labelled.

2.3.3. A notice, indicating that the heater must be shut down before refuelling, must be affixed to the fuelling point. In addition a suitable instruction must be included in the manufacturer's operating manual.

2.4. Exhaust system

2.4.1. The exhaust outlet must be located so as to prevent emissions from entering the vehicle through ventilators, heated air inlets or opening windows.

2.5. Combustion air inlet

2.5.1. The air for the combustion chamber of the heater must not be drawn from the passenger compartment of the vehicle.

2.5.2. The air inlet must be so positioned or guarded that blocking by rubbish or luggage is unlikely.

2.6. Heating air inlet

2.6.1. The heating air supply may be fresh or recirculated air and must be drawn from a clean area not likely to be contaminated by exhaust fumes emitted either by the propulsion engine, the combustion heater or any other vehicle source.

2.6.2. The inlet duct must be protected by mesh or other suitable means.

2.7. Heating air outlet

2.7.1. Any ducting used to route the hot air through the vehicle must be so positioned or protected that no injury or damage could be caused if it were to be touched.

2.7.2. The air outlet must be so positioned or guarded that blocking by rubbish or luggage is unlikely.

End of excerpt.

In multilingual versions the German language is binding.

Information on Validity

This installation documentation applies to Ford Focus / C-Max / Grand C-Max Petrol vehicles - for validity, see page 1 - from model year 2015 and later, assuming technical modifications to the vehicle do not affect installation, any liability claims excluded. Depending on the vehicle version and equipment, modifications may be necessary during installation with respect to this 'installation documentation'.

Vehicle and engine types, equipment variants and other specifications not listed in this installation documentation have not been tested. However, installation according to this installation documentation may be possible.

Technical Information

Special Tools

- Hose clamp pliers for auto-tightening hose clamps
- Hose clamp pliers for Clic hose clamps of type W
- Automatic wire stripper, 0.2 - 6mm²
- Crimping pliers for cable lug / tab connector, 0.5 - 6mm²
- Torque wrench for 2.0 - 10 Nm
- Hose clamping pliers
- Metric thread-setter kit
- Deep-hole marker
- Webasto Thermo Test Diagnosis with current software

Dimensions

- All dimensions are in mm.

Tightening torque values

- Tightening torque values of 5x13 heater bolts and 5x11 heater stud bolts = 8Nm.
- Tightening torque value of 5x15 water connection piece retaining plate bolt = 7Nm.
- Tighten other bolt connections in accordance with manufacturer's instructions or in accordance with state-of-the-art technology.

Explanatory Notes on Document

You will find an identification mark on the outside top right corner of the page in question to provide you with a quick overview of the individual working steps.

Special features are highlighted using the following symbols:

Mechanical System



Electrical System



Coolant Circuit



Combustion Air

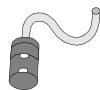

Fuel



Exhaust Gas



Software



Specific risk of damage to components.



Specific risk due to electrical voltage.



Specific risk of injury or fatal accidents.



Specific risk of fire or explosion.



Reference to the manufacturer's vehicle-specific documents or to the general installation instructions of Webasto components.



Reference to a special technical feature.



The arrow in the vehicle icon indicates the position on the vehicle and the viewing angle.



Tightening torque according to the manufacturer's vehicle-specific documents.



Preliminary Work

Vehicle



- Open the fuel tank cap.
- Ventilate the fuel tank.
- Close the fuel tank cap again.
- Depressurise the cooling system.
- Disconnect and remove the battery.
- Remove the engine cover.
- Remove the windscreen wiper.
- Remove the upper cover of the coolant reservoir.
- Remove the cover of the coolant reservoir for the engine compartment.
- Drain the coolant according to the manufacturer's instructions.
- Remove the intake hose.
- Remove the engine underdrive protection.



- Remove the underbody trim on the right next to the tank.
- Detach the heat protection trim of the exhaust system in the area of the tank.
- Remove the fuel tank according to the manufacturer's instructions.
- Remove the footwell trim on the front passenger's side.
- Remove the A-pillar trim of the footwell on the front passenger's side (only in case of Telestart).
- Remove the A-pillar trim on the front passenger's side (only in case of Telestart and/or ThermoCall for C-Max / Grand C-Max)

Heater

- Remove years that do not apply from the type and duplicate label.
- Attach the duplicate label (type label) visibly in the appropriate place in the engine compartment.

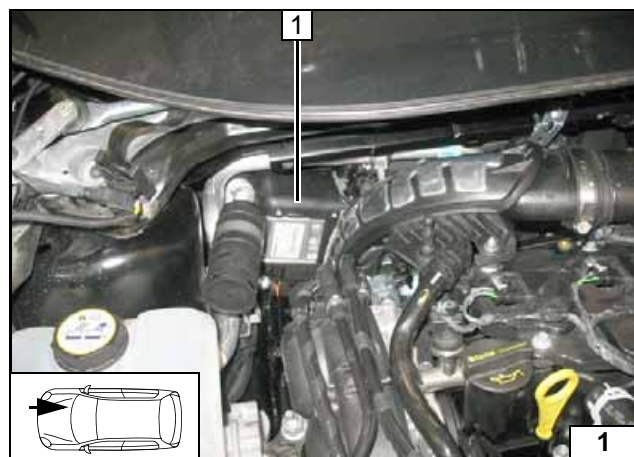

Heater Installation Location

- 1 Heater

Installation location

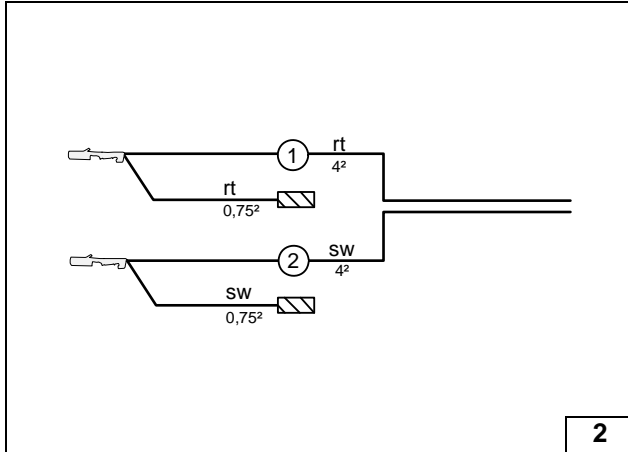

Preparing Electrical System

Wire sections retain their numbering in the entire document.

Manual air-conditioning

- ① Red (rt) wire of fan wiring harness
- ② Black (sw) wire of fan wiring harness



Assigning wires

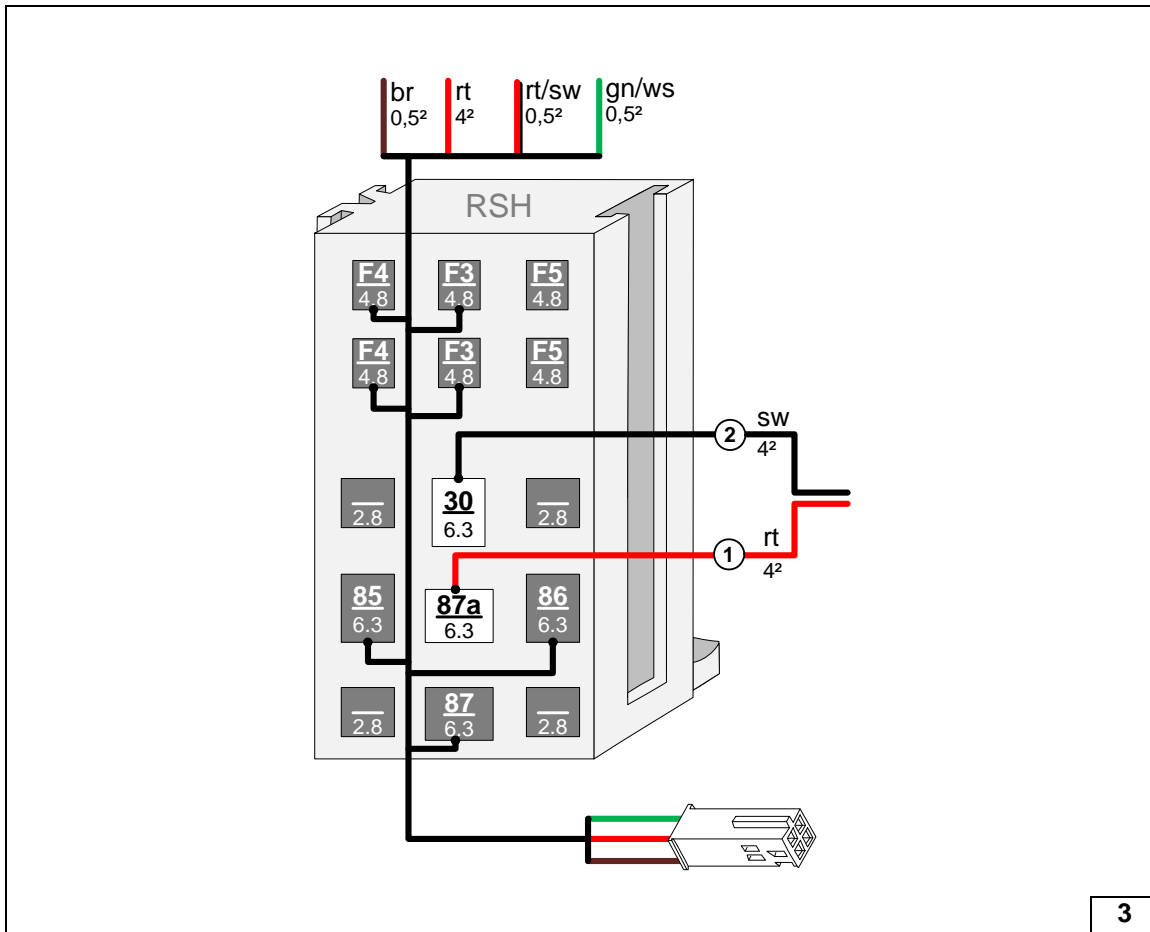

Connecting wires to passenger compartment relay and fuse holder

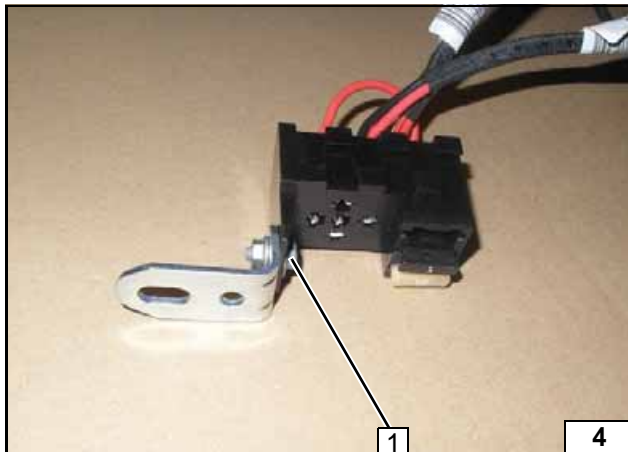

Focus only

- 1 M5x16 bolt, large diameter washer, passenger compartment relay and fuse holder, angle bracket, large diameter washer, nut

Premounting angle bracket

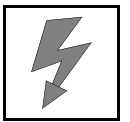

Wiring Harness Routing for Focus



Positive wire

- 1 Positive wire on positive support point

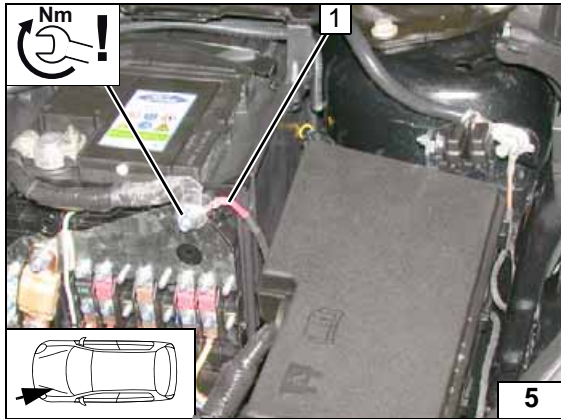

Wiring harness pass through

- 1 Protective rubber plug

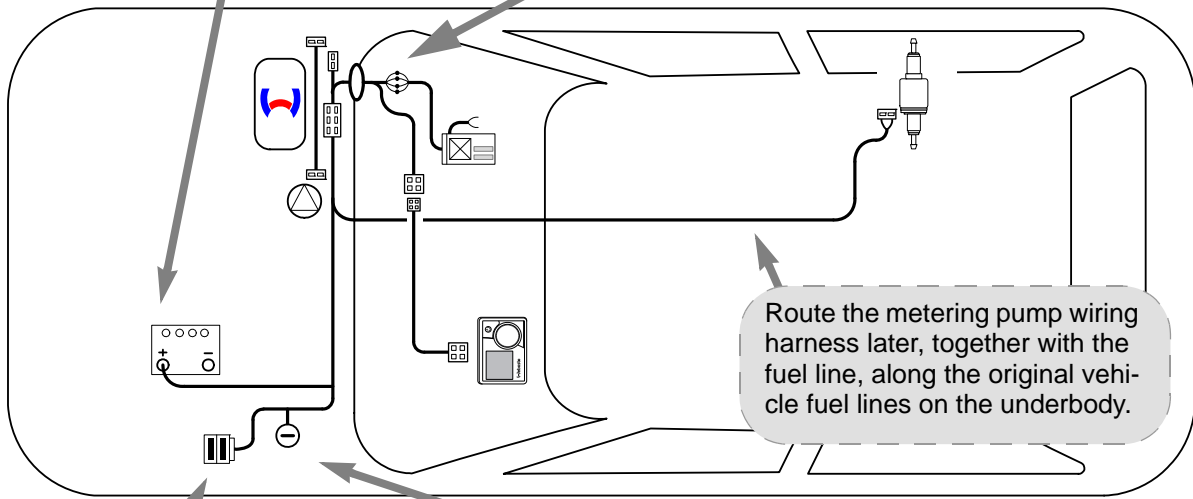
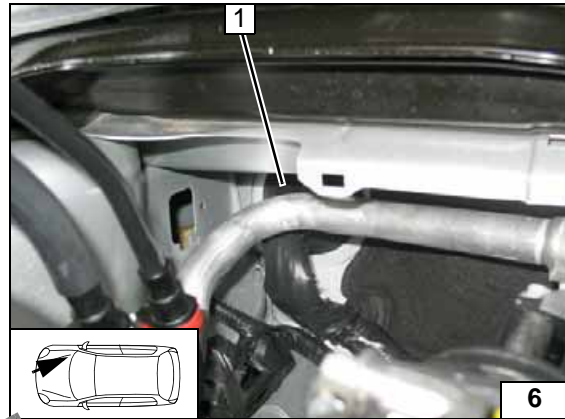

Wiring harness routing diagram (manual A/C)

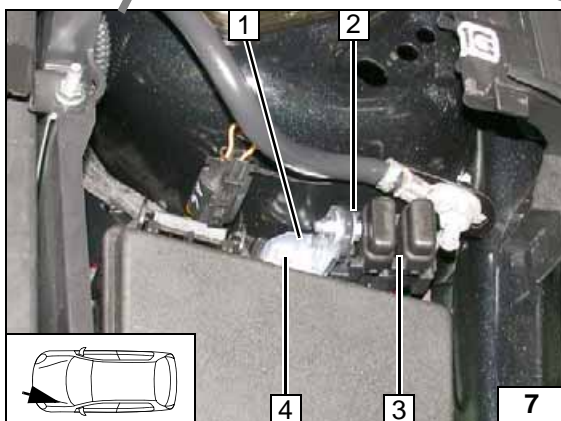

Engine compartment fuse holder

- 1 Angle bracket
- 2 M5x16 bolt, large diameter washer [2x], retaining plate of fuse holder, nut
- 3 Fuses F1-2
- 4 M6x20 bolt, flanged nut, existing hole

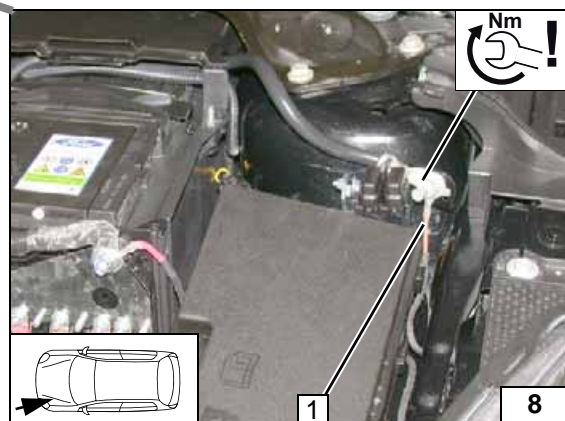

Earth wire

- 1 Earth wire, 8 mm dia. cable lug at original vehicle earth support point



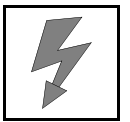

Wiring Harness Routing for C-Max / Grand C-Max



Positive wire

- 1 Positive wire on positive battery terminal

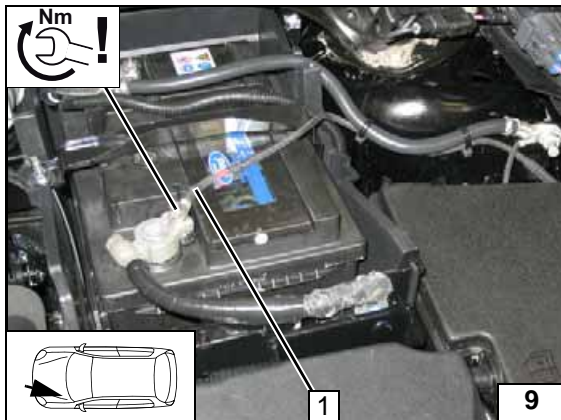

Wiring harness pass through

- 1 Protective rubber plug

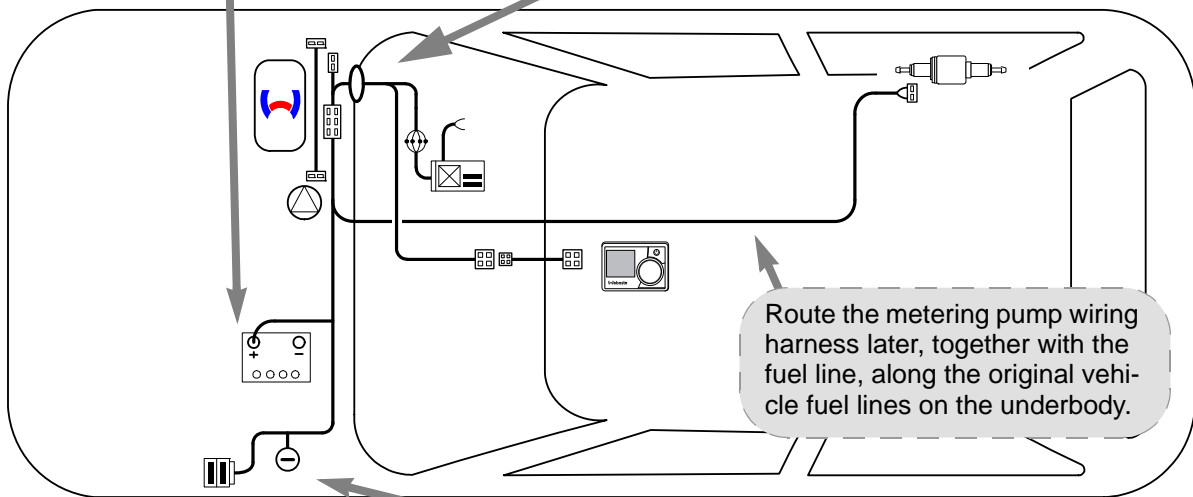
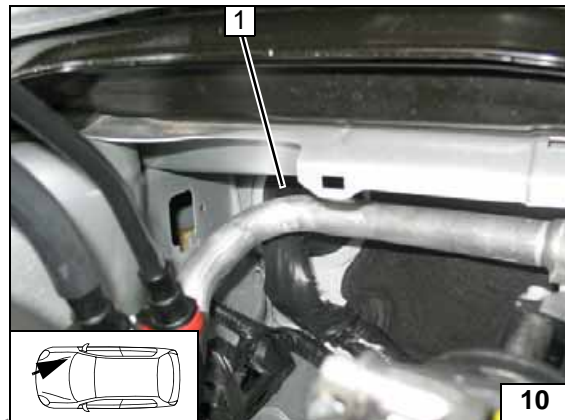

Wiring harness routing diagram (manual A/C)

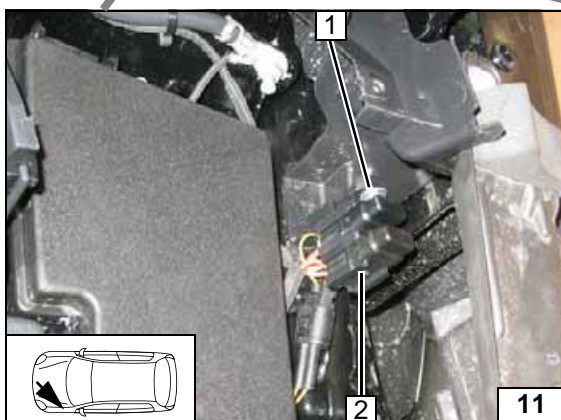

Engine compartment fuse holder

When drilling, be careful of components located behind!

- 1 5.5mm dia. hole, M5x16 bolt, large diameter washer, retaining plate of fuse holder, nut
- 2 Fuses F1-2

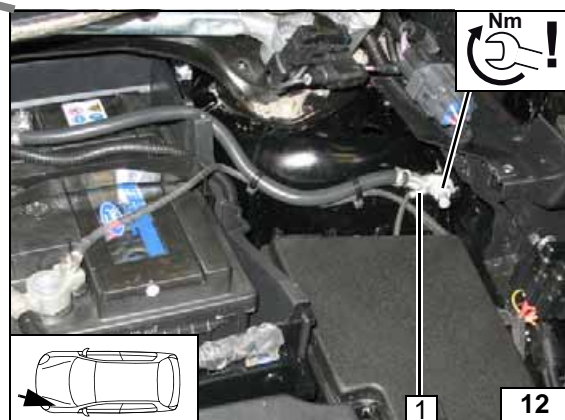

Earth wire

- 1 Earth wire, 8 mm dia. cable lug at original vehicle earth support point



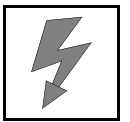

Manual Air-Conditioning Fan Controller

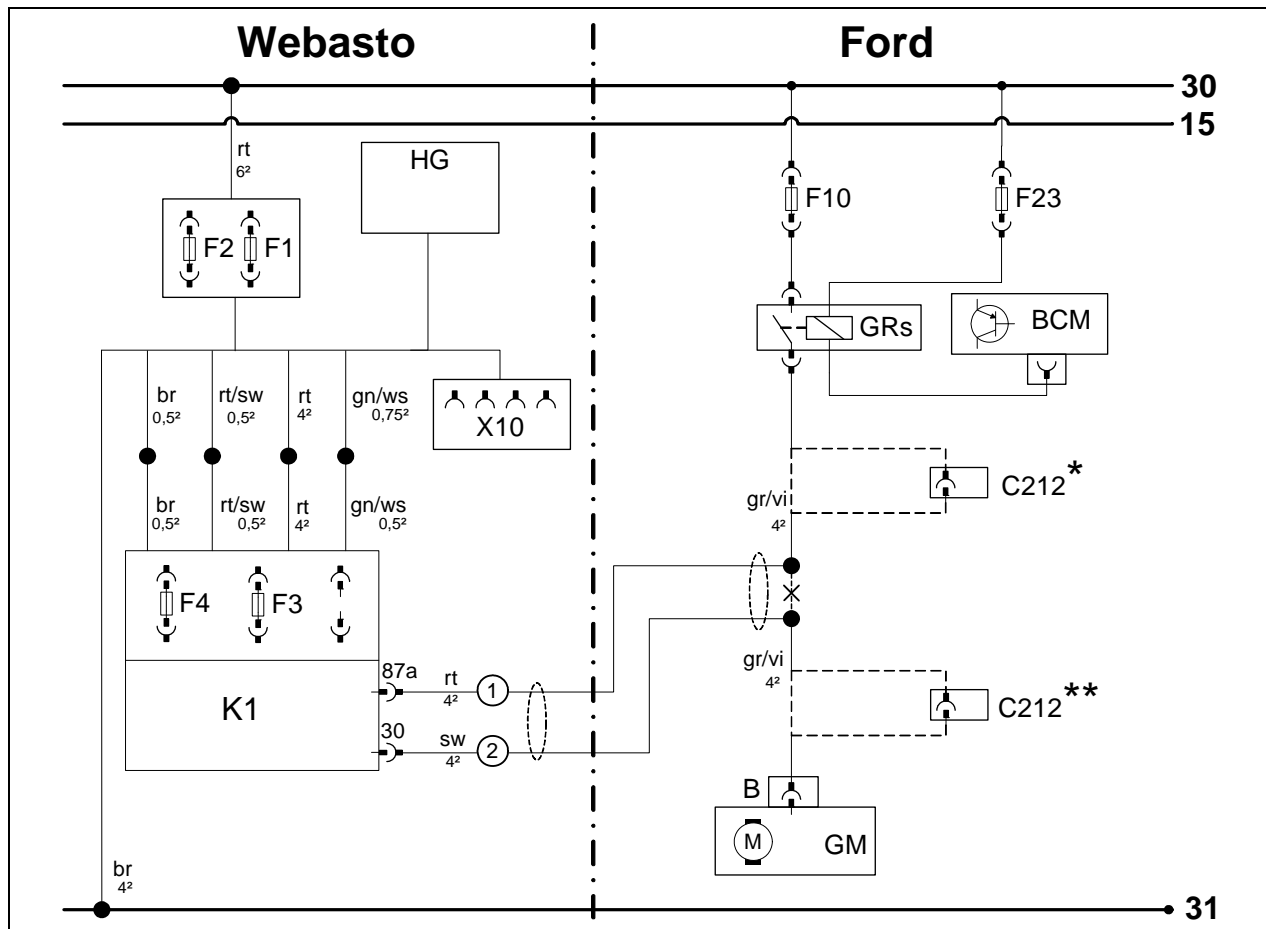

System wiring diagram

Webasto components		Vehicle components		Colours and symbols	
HG	TT-Evo heater	F10	40A fuse	rt	red
F1	20A fuse	F23	5A fuse	sw	black
F2	30A fuse	BCM	Body control unit	gn	green
X10	4-pin connector of heater control	GRs	Fan relay	ws	white
F3	1A fuse	C212 *	Connector for Focus	br	brown
F4	25A fuse	C212 **	Connector for C-Max / Grand C-Max	gr	grey
K1	Fan relay			vi	violet
		GM	Fan motor	X	Cutting point
		B	Fan motor connector	Wiring colours may vary.	

Legend

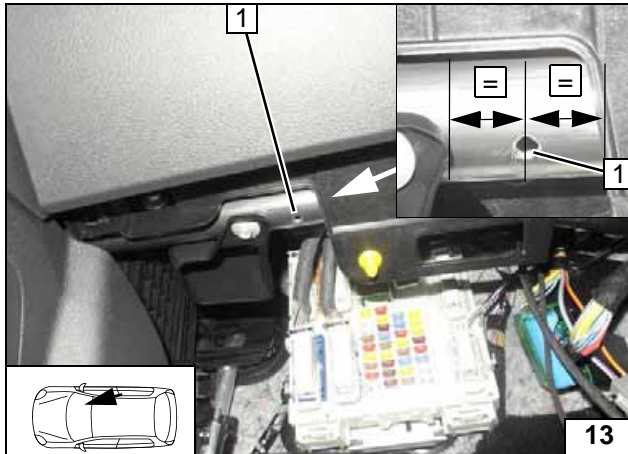
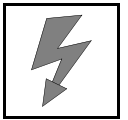

Fan Controller for Focus

- 1 5mm dia. hole

Drilling hole in instrument panel carrier

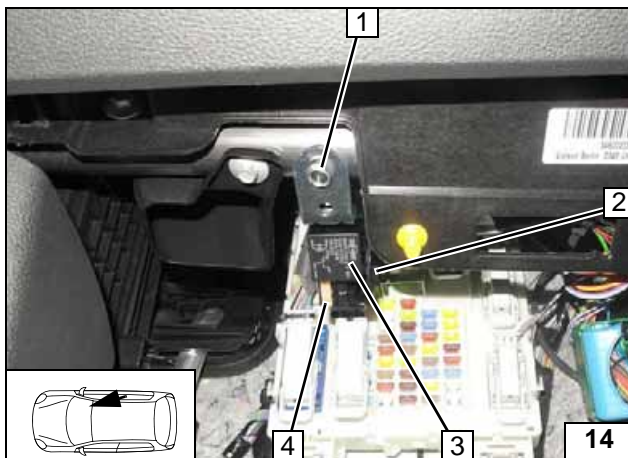

- 1 Self-tapping screw, angle bracket pre-mounted
- 2 Passenger compartment relay and fuse holder
- 3 Relay K1
- 4 25A fuse F4

Installing passenger compartment relay and fuse holder

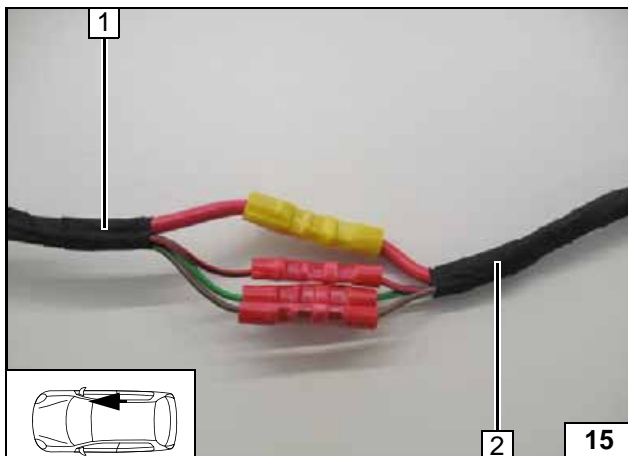

- 1 Passenger compartment relay and fuse holder wiring harness
- 2 Heater wiring harness

Connecting same colour wires of wiring harnesses

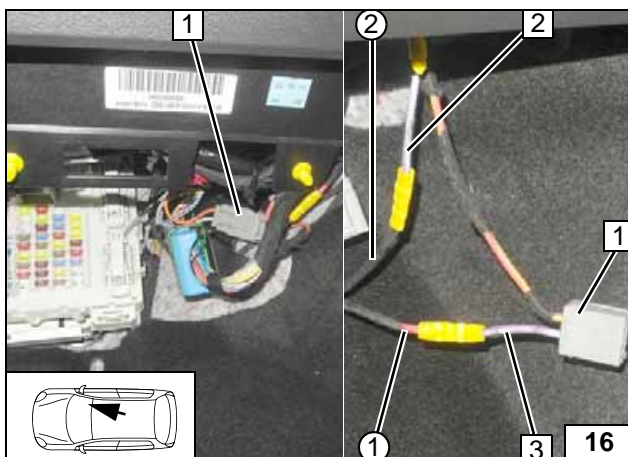

- 1 Connector C212
- 2 Grey/violet (gr/vi) wire of GRs connector
- 3 Grey/violet (gr/vi) wire of connector C212
- ① Red (rt) wire of K1/87a, fan wiring harness
- ② Black (sw) wire of K1/30, fan wiring harness

Connecting fan motor

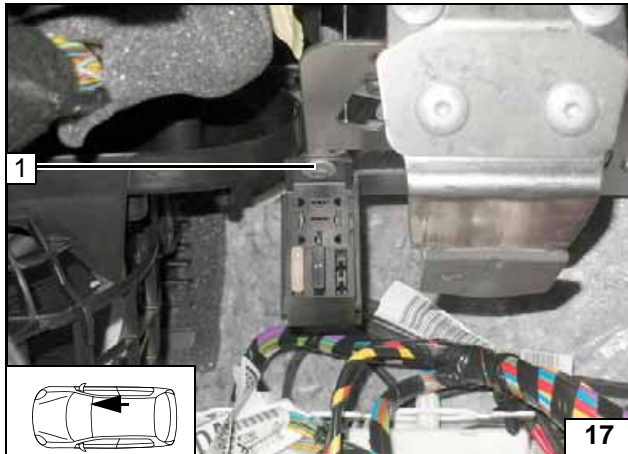
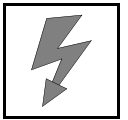

Fan Controller for C-Max / Grand C-Max

- 1 M5x16 bolt, large diameter washer, passenger compartment relay and fuse holder tab, original vehicle hole, large diameter washer, nut

Installing passenger compartment relay and fuse holder

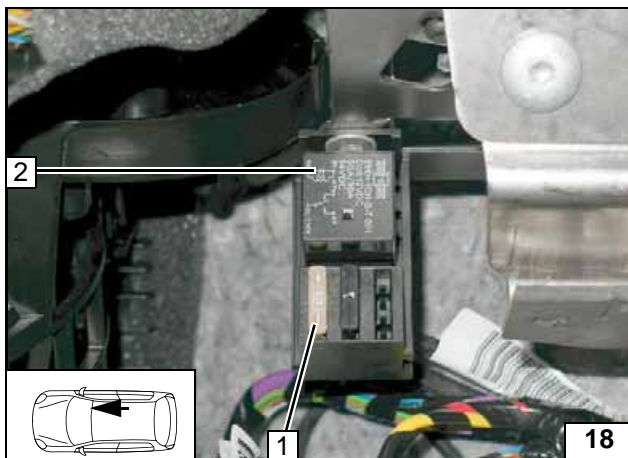

- 1 25A fuse F4
- 2 Relay K1

Inserting fuse F4 and relay K1

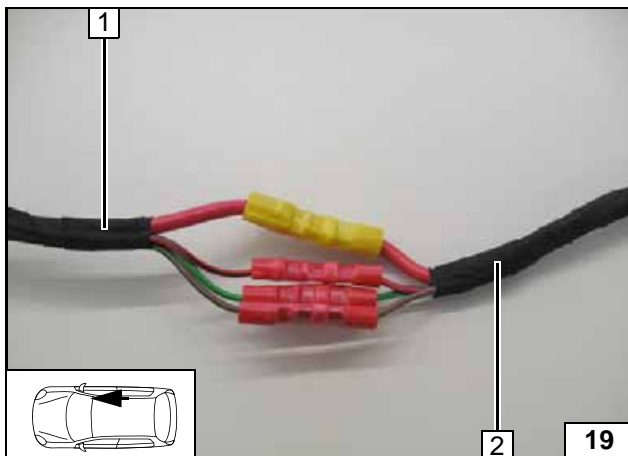

- 1 Passenger compartment relay and fuse holder wiring harness
- 2 Heater wiring harness

Connecting same colour wires of wiring harnesses

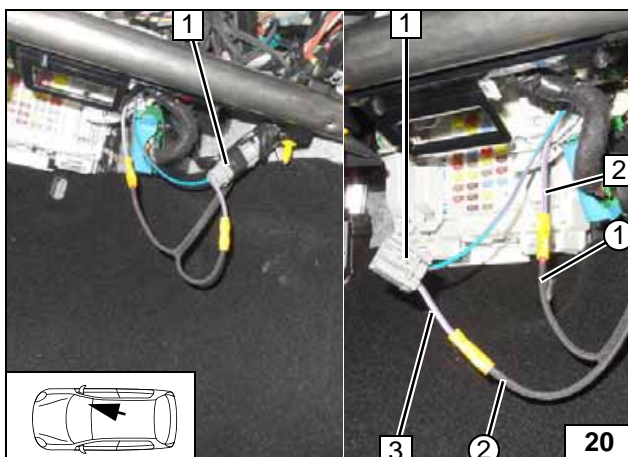

- 1 Connector C212
- 2 Grey/violet (gr/vi) wire of GRs
- 3 Grey/violet (gr/vi) wire of connector C212
- ① Red (rt) wire of K1/87a, fan wiring harness
- ② Black (sw) wire of K1/30, fan wiring harness

Connecting fan motor

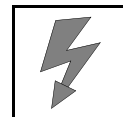

Automatic A/C Control



The connection of the A/C control has to be carried out in accordance with the separate installation documentation:

Installation documentation '**Webasto Standard**' A/C control for Ford Focus / C-Max / Grand C-Max with AC and AAC

or

Installation documentation '**Webasto Comfort**' A/C control for Ford Focus / C-Max / Grand C-Max with AAC

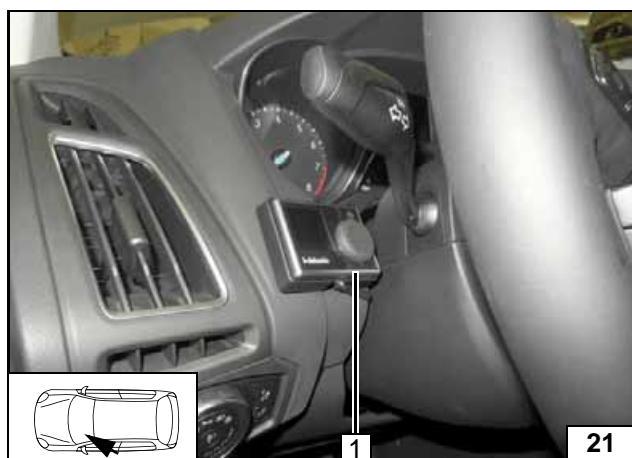

Focus Heater Control

MultiControl CAR Option

- 1 Installation frame



Installing MultiControl CAR

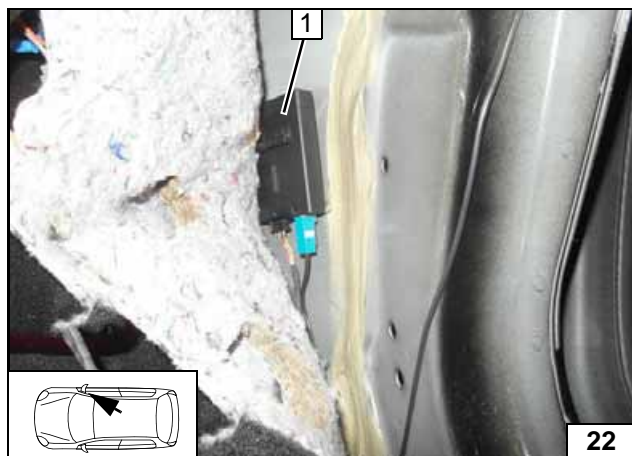

Remote Option (Telestart)

Fasten receiver 1 with double-sided adhesive tape.



Installing receiver

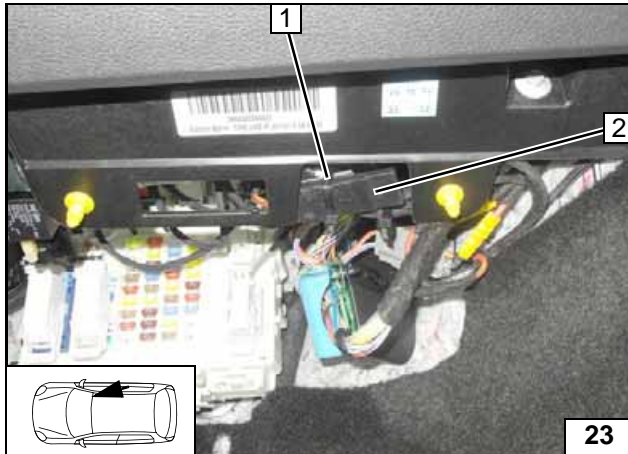
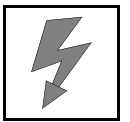

Temperature sensor T100 HTM

Fasten temperature sensor 2 with cable tie 1 to original vehicle wiring harness.



Installing temperature sensor

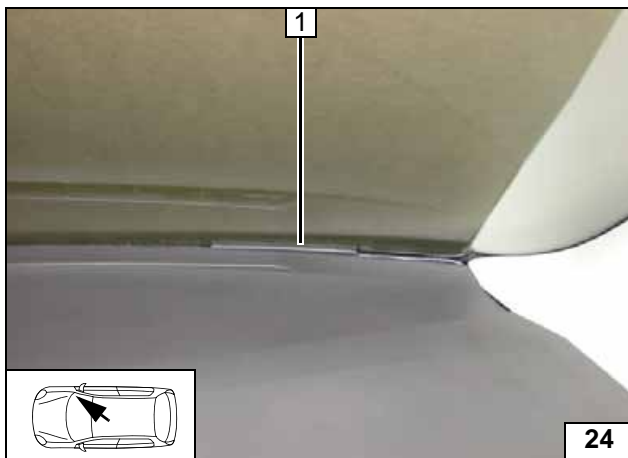

1 Aerial



Installing aerial

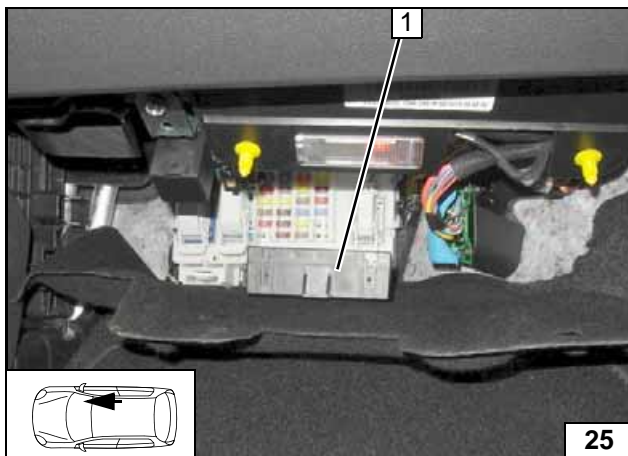

ThermoCall Option

Fasten receiver 1 with double-sided adhesive tape onto the footwell trim.



Installing receiver

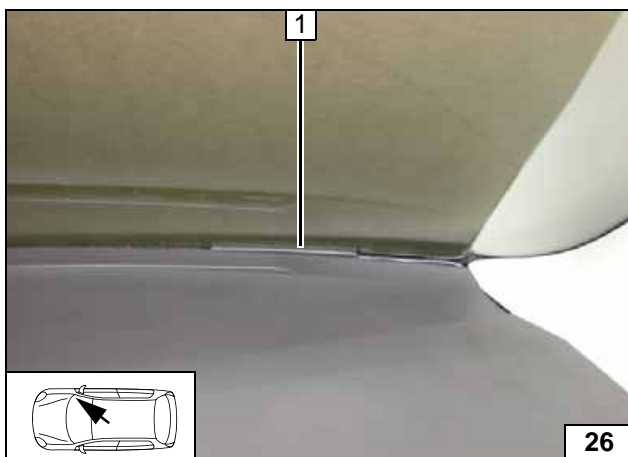

1 Aerial (optional)



Installing aerial

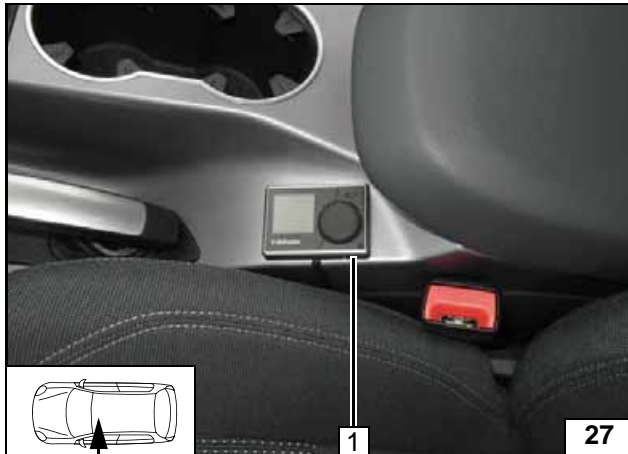
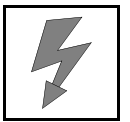

C-Max / Grand C-Max Heater Control

MultiControl CAR Option

- 1 Installation frame



Installing MultiControl CAR

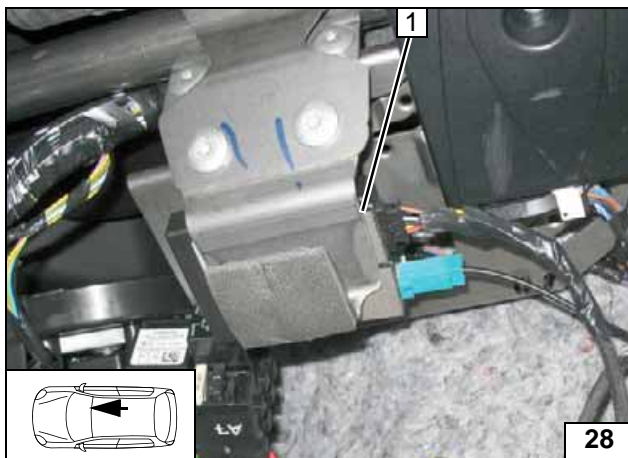

Remote Option (Telestart)

Fasten receiver 1 with double-sided adhesive tape.



Installing receiver

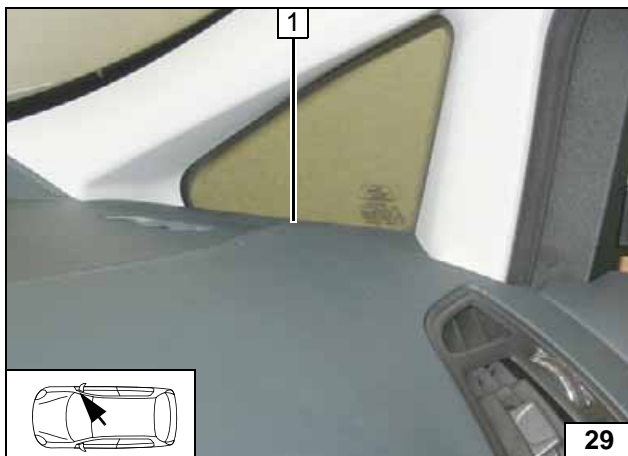

- 1 Aerial

Installing aerial

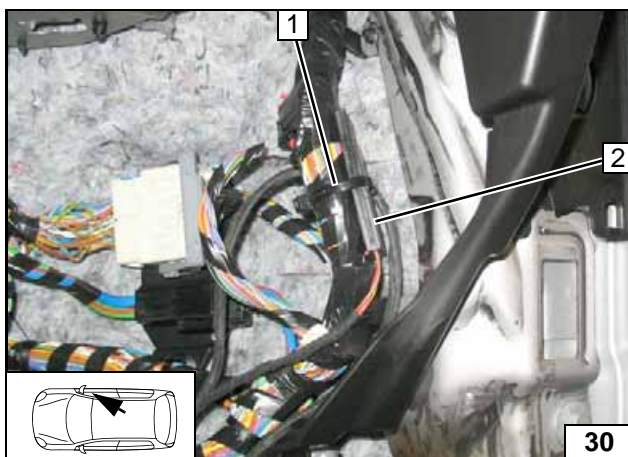

Temperature sensor T100 HTM

Fasten temperature sensor 2 with cable tie 1 to original vehicle wiring harness.



Installing temperature sensor

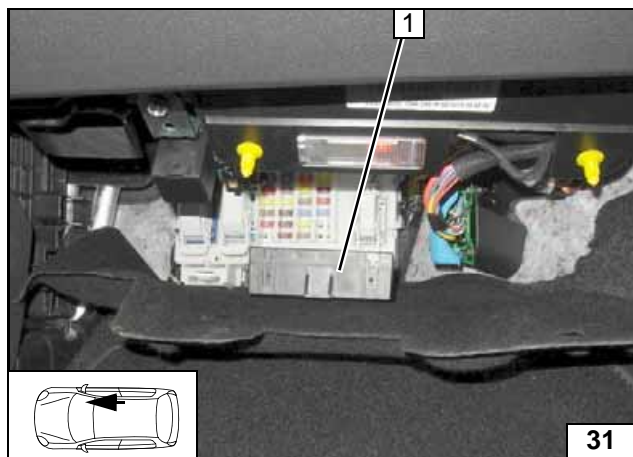

ThermoCall Option

Fasten receiver 1 with double-sided adhesive tape onto the footwell trim.



Installing receiver

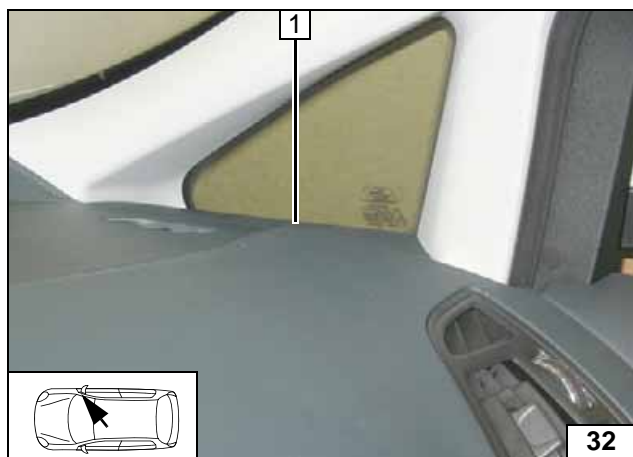

1 Aerial (optional)

Installing aerial

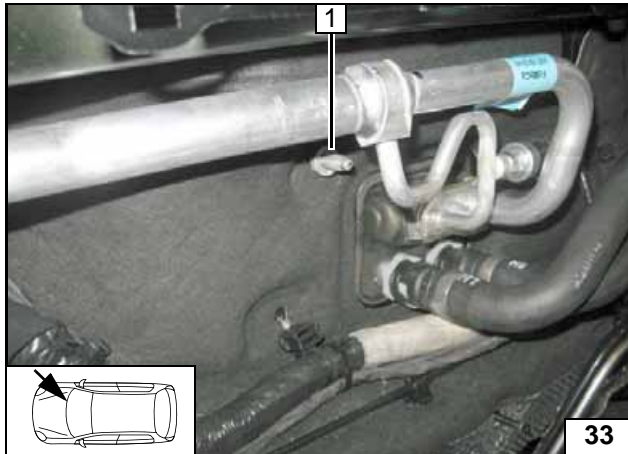
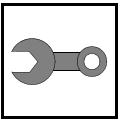

Preparing Installation Location

Screw M8 flanged nut 1 (nut is shown in the engine compartment) approx. 15mm on the original vehicle stud bolt.



Premounting flanged nut

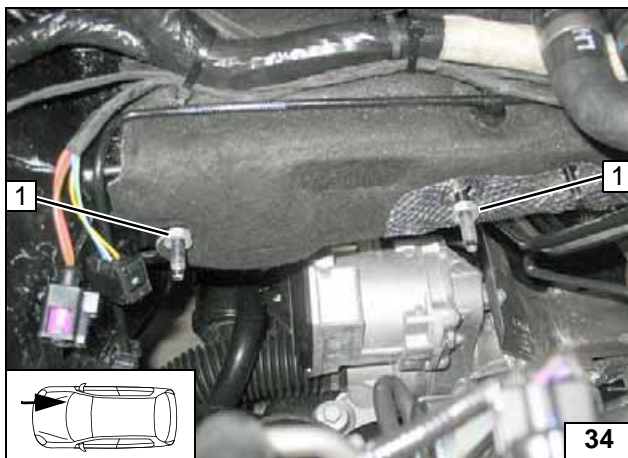

Screw one M8 flanged nut each 1 (nut is shown in the engine compartment) approx. 25mm on the original vehicle stud bolt.



Premounting flanged nut

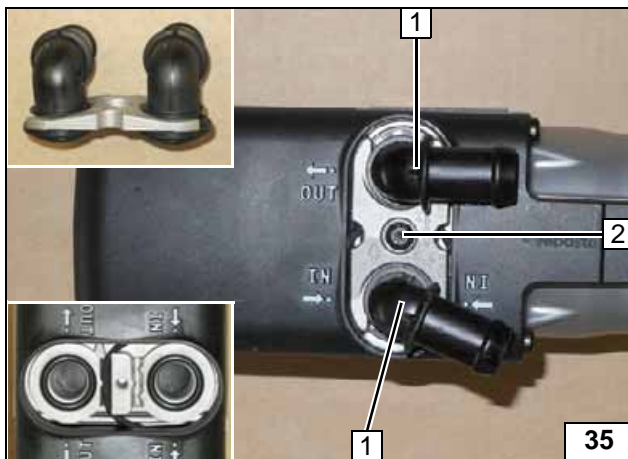

Preparing Heater

- 1 Water connection piece, sealing ring [2x each]
- 2 5x15 self-tapping bolt, retaining plate of water connection piece



Installing water connection piece

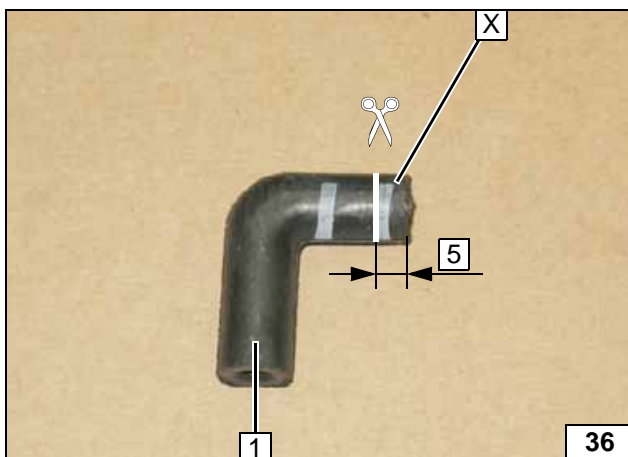

- 1 90° moulded hose

X =

Cutting moulded hose to length

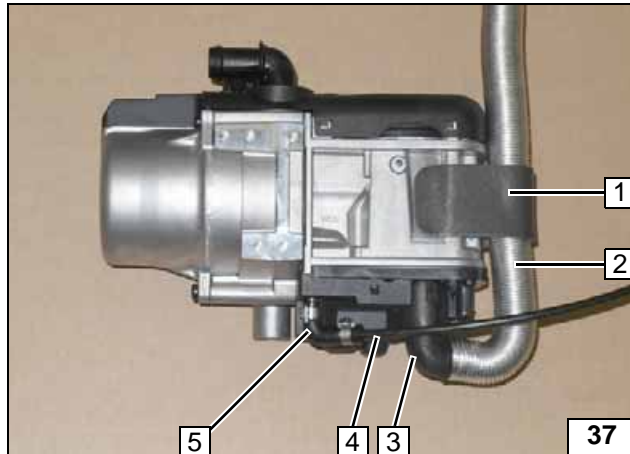
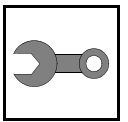

Mount combustion air pipe **2** on heater with insulation strip **1** as installation aid.

- 3** Air-intake manifold
- 4** Fuel line
- 5** 90° moulded hose, 10 mm dia. clamp [2x]

Premounting heater

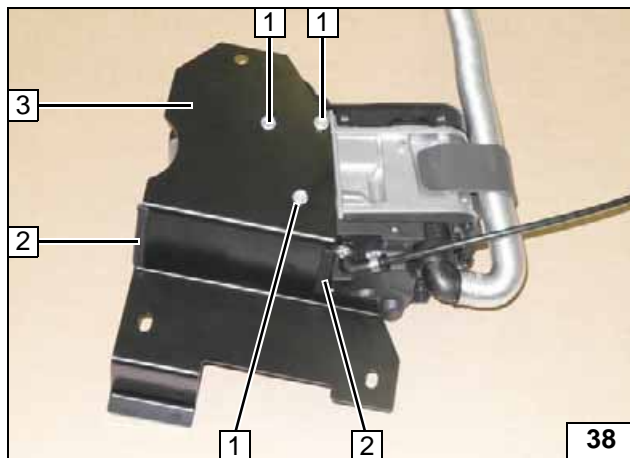

- 1** 5x13 self-tapping bolt [3x]
- 2** Edge protection cut in half, 50mm each [2x]
- 3** Bracket

Installing bracket

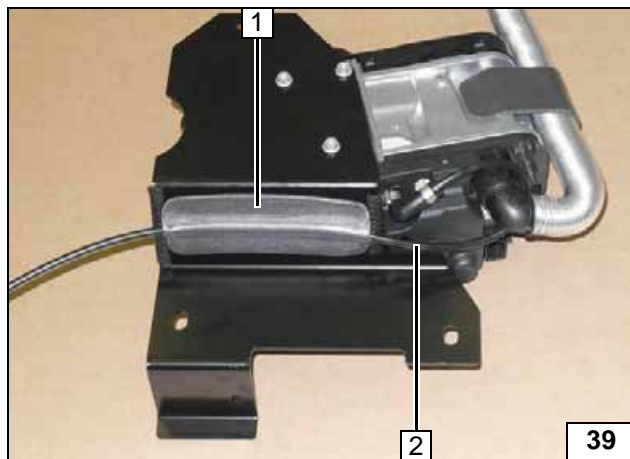

- 1** Insulation strips
- 2** Fuel line

Mounting fuel line

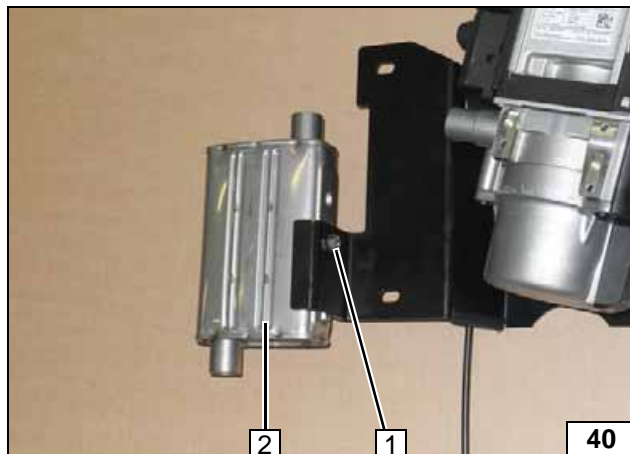

- 1** M6x16 bolt, spring lockwasher
- 2** Exhaust silencer

Installing exhaust silencer

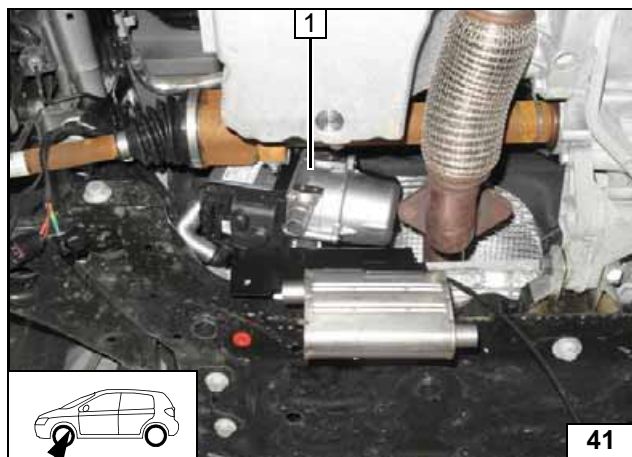
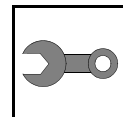

Installing Heater

Install heater 1 from below on firewall.

Installing assembly

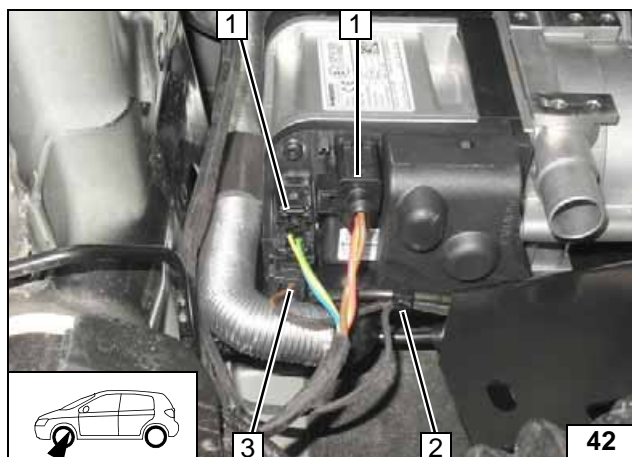

- 1 Heater wiring harness connector [2x]
- 2 Cable tie around circulating pump and metering pump wiring harnesses as well as fuel line
- 3 Connector of circulating pump wiring harness

Installing/fixing wiring harnesses



- 1 Cable tie around circulating pump wiring harness and metering pump as well as fuel line

Fixing wiring harnesses

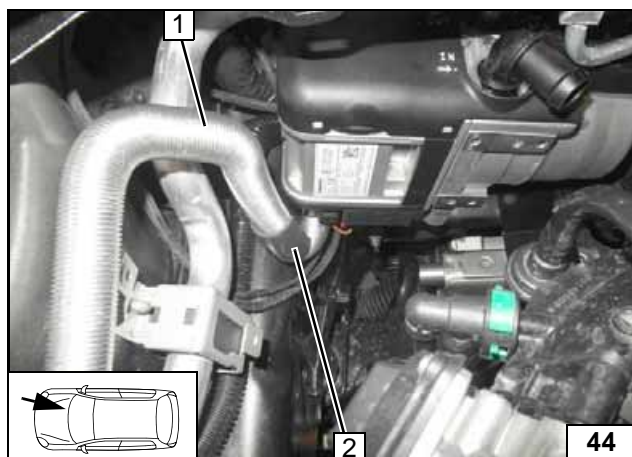

Loosen combustion air pipe 1 from insulation strip 2 and turn forwards.

Routing combustion air pipe

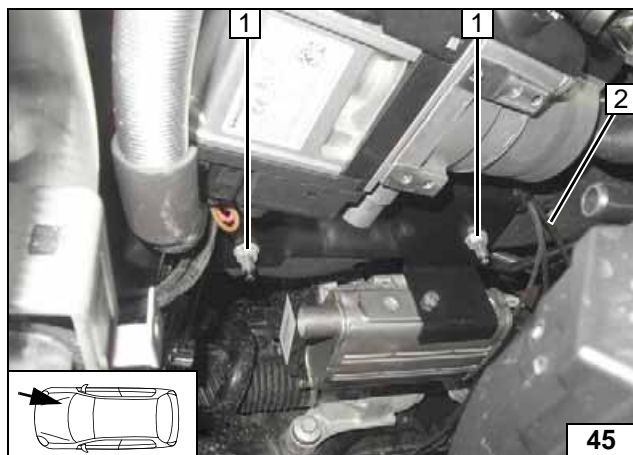
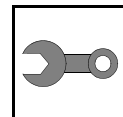

Mount heater with bracket on original vehicle stud bolt [3x]. Pull fuel line 2 with wiring harness of metering pump into 10 mm dia., 2100 mm long corrugated tube and route to the underbody along original vehicle lines.



Installing heater

- 1 M8 flanged nut [2x]

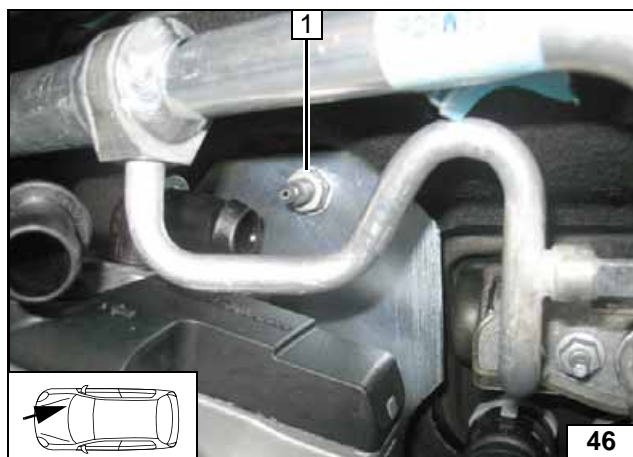

- 1 M8 flanged nut

Installing heater

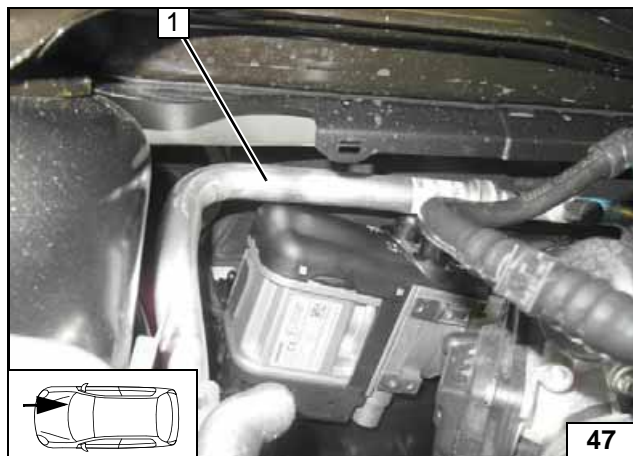

Align heater as shown. Ensure sufficient distance from neighbouring components, especially from A/C line 1, correct if necessary.



Installing heater



Fuel



Open the vehicle's fuel tank cap, ventilate the tank and then re-close the tank lock.

Catch any fuel running off in an appropriate container.



Route fuel line and metering pump wiring harness so that they are protected against stone impact. Unless specified otherwise, always fasten using cable ties.

Provide rub protection for fuel line and wiring harness in areas where there are sharp edges.

The fuel line and wiring harness are routed to the metering pump as shown in the wiring harness routing diagram.

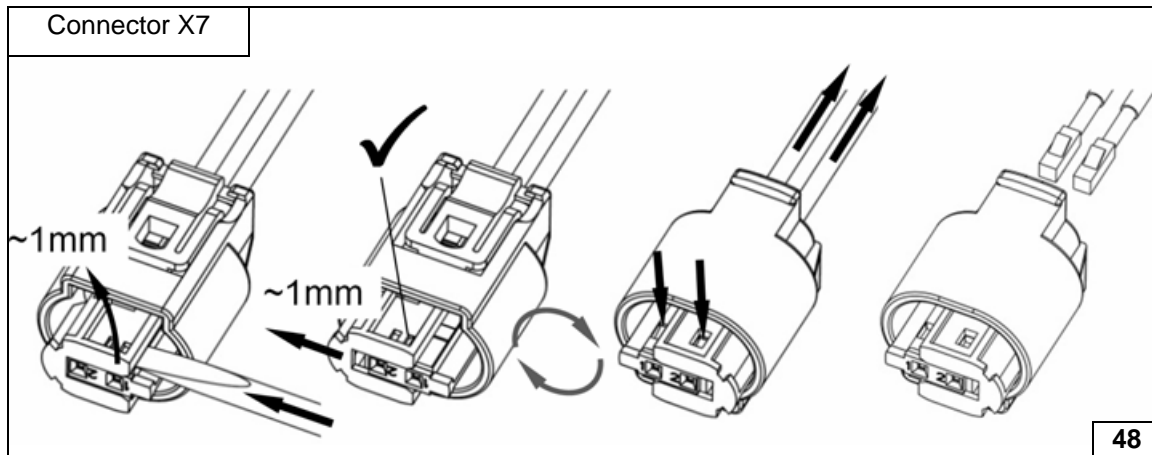

Dismantling metering pump connector

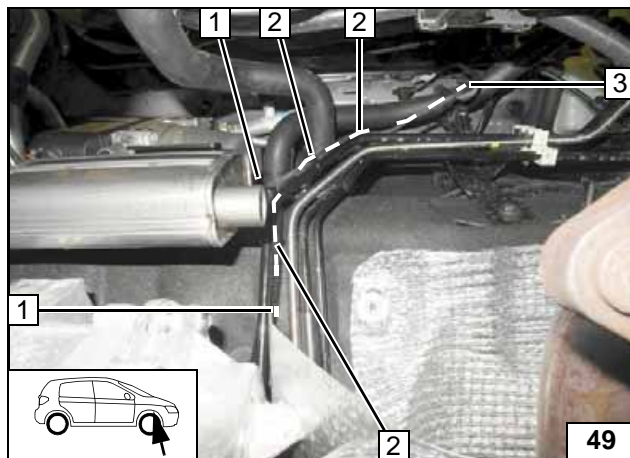

Route fuel line and wiring harness of metering pump in 10 mm dia. corrugated tube 1 along original vehicle fuel lines to underbody.

- 2 Cable tie [3x]
- 3 Circulating pump wiring harness

Routing lines



Route fuel line and wiring harness of metering pump in 10mm dia. corrugated tube 1 along original vehicle fuel lines to installation location of metering pump.

Routing lines

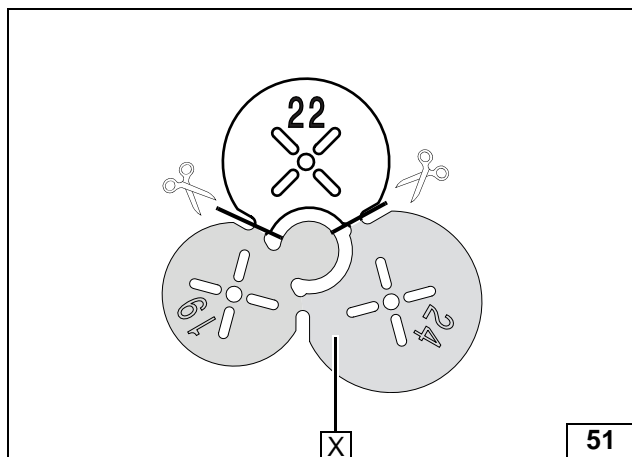
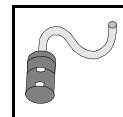

Installing FuelFix

X =



Preparing drilling template

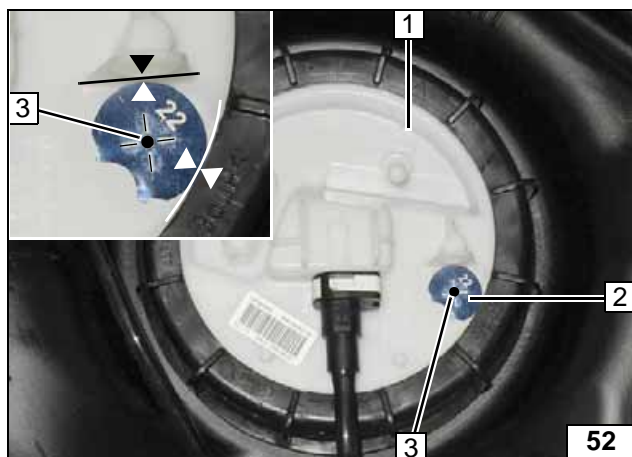

Remove the fuel tank according to the manufacturer's instructions.



Work steps F1 and F2.



- 1 Fuel tank sending unit
- 2 Position 22mm dia. template as shown
- 3 Hole pattern

Copying hole pattern



Work step F3.

- 1 Hole made with provided drill

Hole for FuelFix

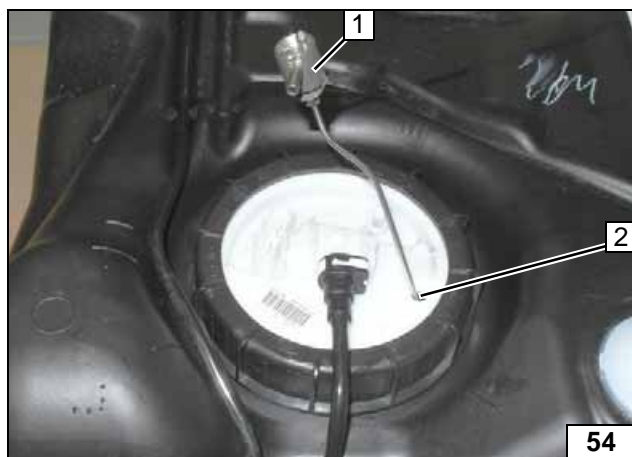

Work steps F4 and F5.

Bend FuelFix 1 according to template and cut to length. Insert into hole 2.



Inserting FuelFix



Work step F5.

Inserting
FuelFix



Inserting
FuelFix



Inserting
FuelFix

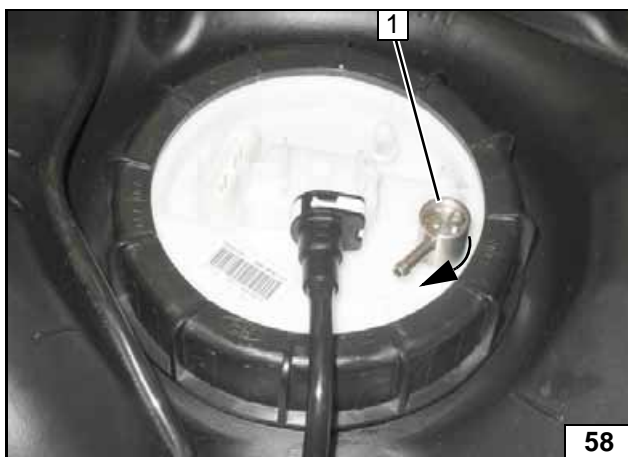

Work steps F5.3 and F5.4.

Align FuelFix 1 as shown.



Aligning
FuelFix

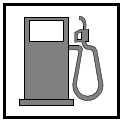

Work step F6.

- 1 FuelFix
- 2 Hose section, 10mm dia. clamp [2x]
- 3 Fuel line

Connect-
ing fuel line

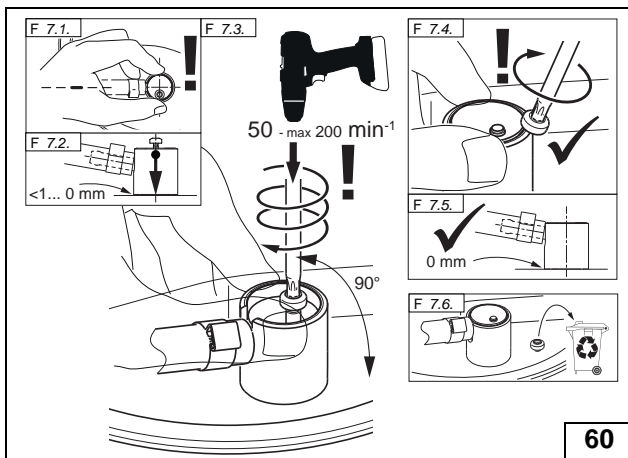

Work step F7.



Installing
FuelFix



Work step F8.



Ensuring
firm seating
of FuelFix



- 1 FuelFix mounted
- 2 Fuel line of FuelFix
- 3 Cable tie as tension relief

Securing
fuel line



Install fuel tank in accordance with manu-
facturer's instructions.

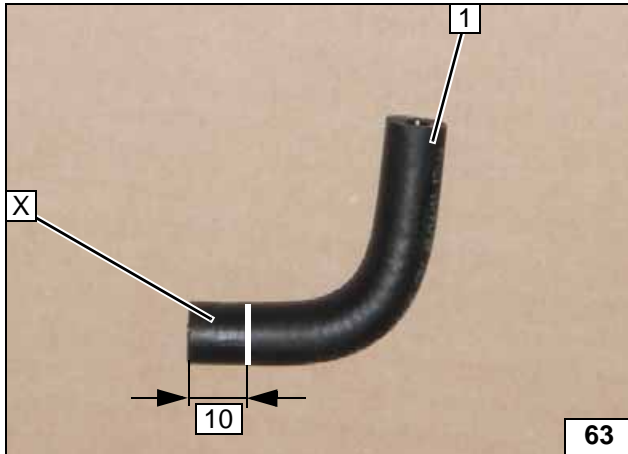
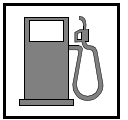

1 90° moulded hose

X =

Cutting moulded hose to length

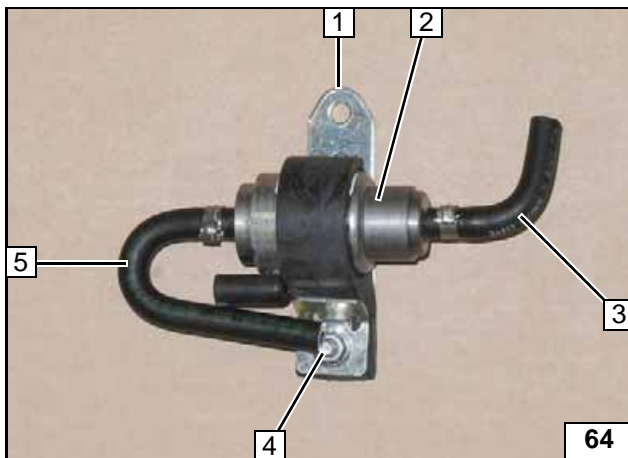

- 1 Perforated bracket
- 2 Metering pump
- 3 90° moulded hose (shortened side to metering pump), 10 mm dia. clamp
- 4 M6x25 bolt, perforated bracket 1, mounting of metering pump, support angle bracket, flanged nut
- 5 180° moulded hose, 10 mm dia. clamp

Premounting metering pump

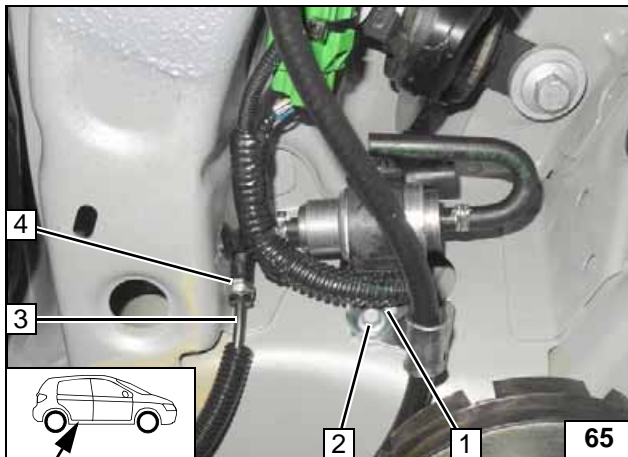

- 1 Premounted perforated bracket
- 2 Original vehicle bolt
- 3 FuelFix fuel line in corrugated tube
- 4 10 mm dia. clamp



Installing metering pump

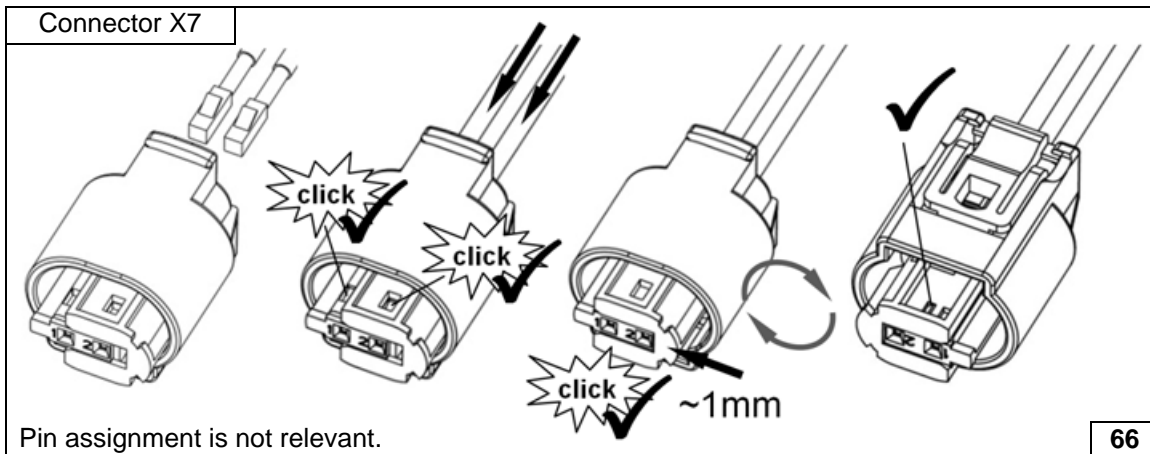

Pin assignment is not relevant.

66

Completing metering pump connector

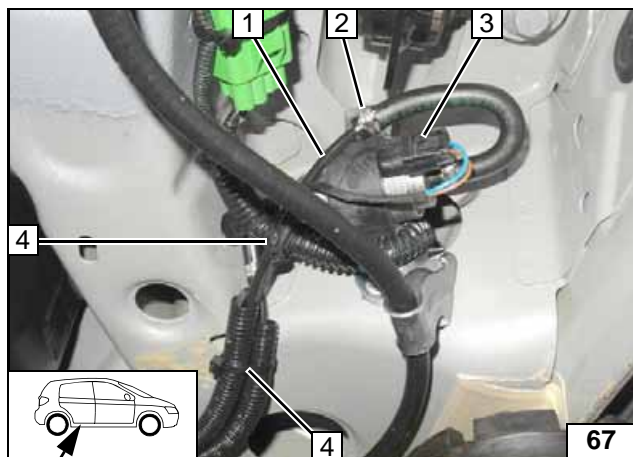
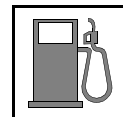

Check the position of the components; adjust if necessary. Check that they have freedom of movement.

- 1 Heater fuel line
- 2 10 mm dia. clamp
- 3 Metering pump wiring harness, connector X7 mounted
- 4 Cable tie [2x]



**Connect-
ing meter-
ing pump**

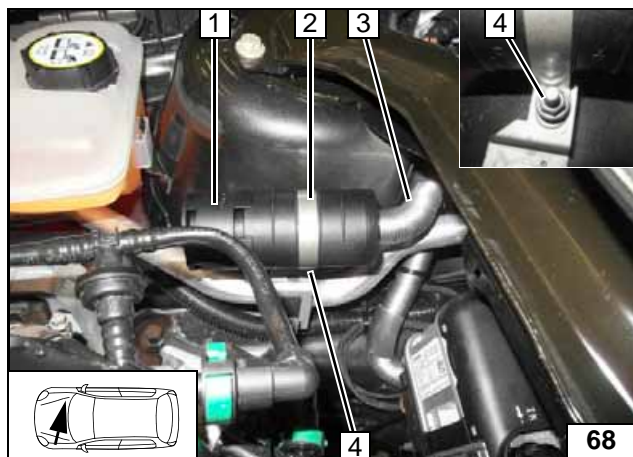
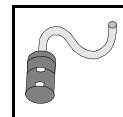

Combustion Air

- 1 Silencer
- 2 51 mm dia. clamp
- 3 Combustion air pipe
- 4 M5x16 bolt, washer, existing hole, clamp 2, flanged nut



**Installing
silencer**

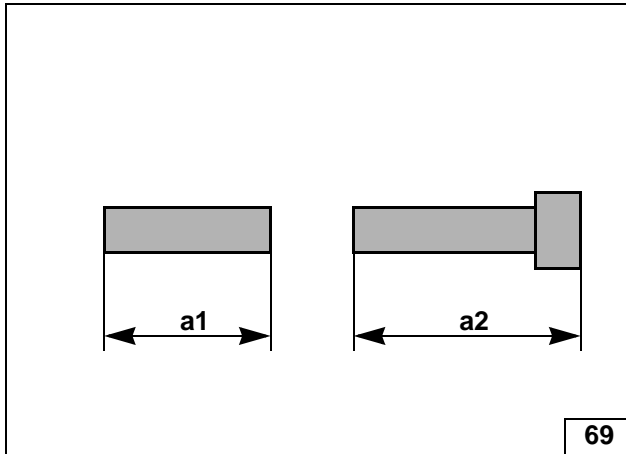
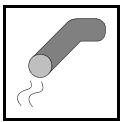

Exhaust Gas

a1 = 190
a2 = 350

Assigning
exhaust
pipes

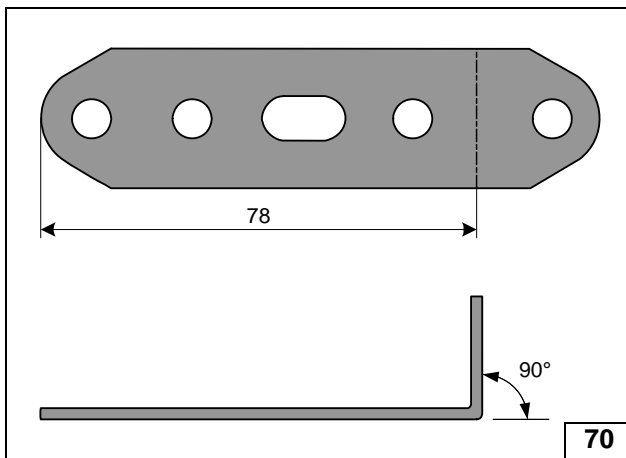

Angling
down perforated
bracket

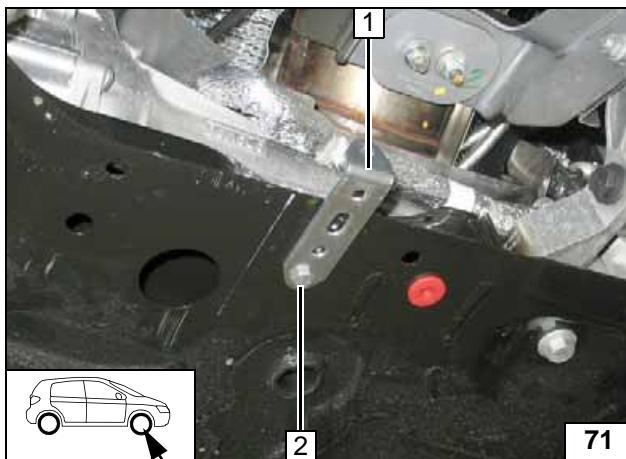

- 1 Perforated bracket
- 2 M6x20 bolt, flanged nut, existing hole

Installing
perforated
bracket

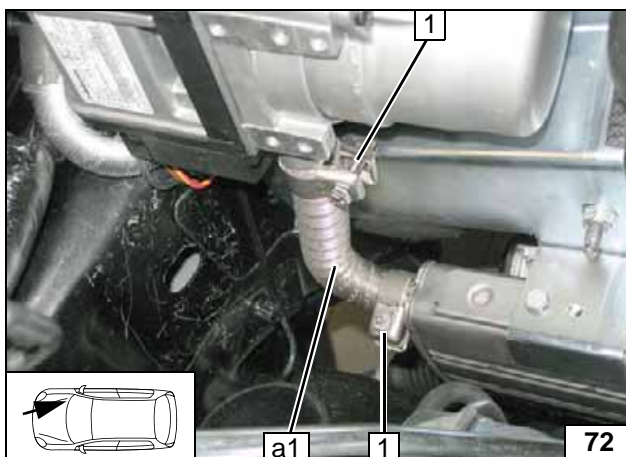

- 1 Hose clamp [2x]

Installing
exhaust
pipe a1

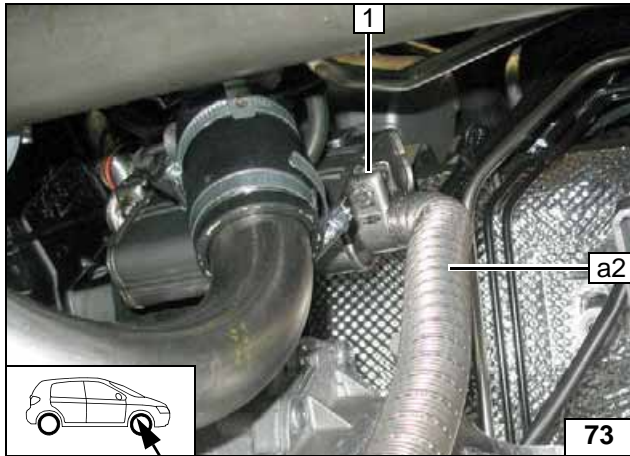
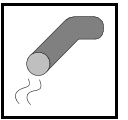

1 Hose clamp

Installing exhaust pipe a2

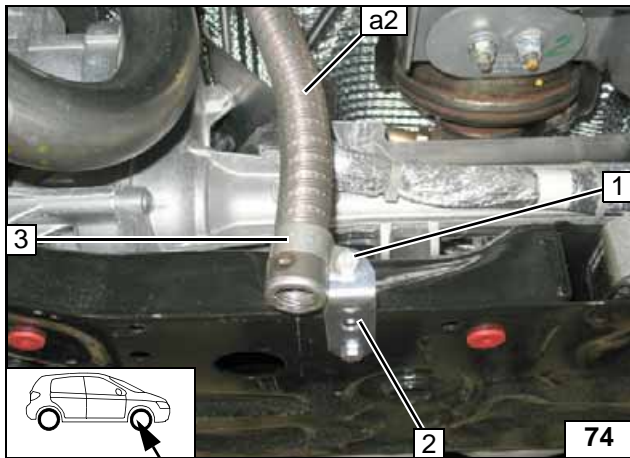

- 1 M6x20 bolt, flanged nut
- 2 Perforated bracket
- 3 P-clamp

Attaching exhaust pipe a2

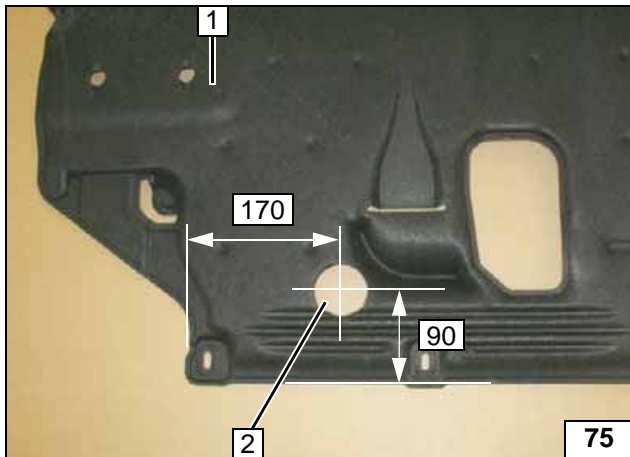

- 1 Underride protection
- 2 60 mm dia. hole

Cutting out underride protection

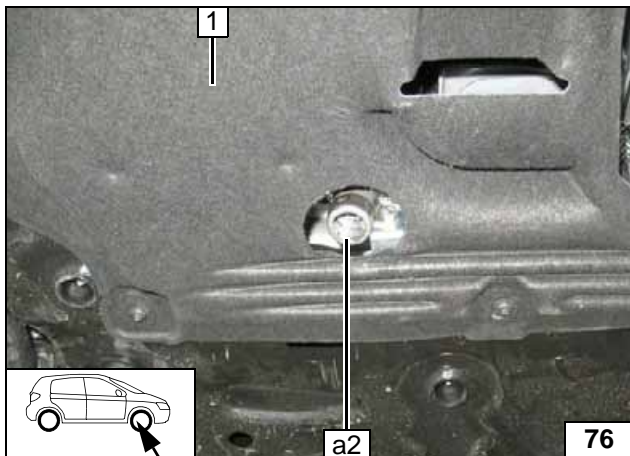

Mount underride protection of engine 1. Align exhaust pipe a2 flush with underride protection 1. Ensure sufficient distance from neighbouring components.



Aligning exhaust pipe a2



Coolant Circuit





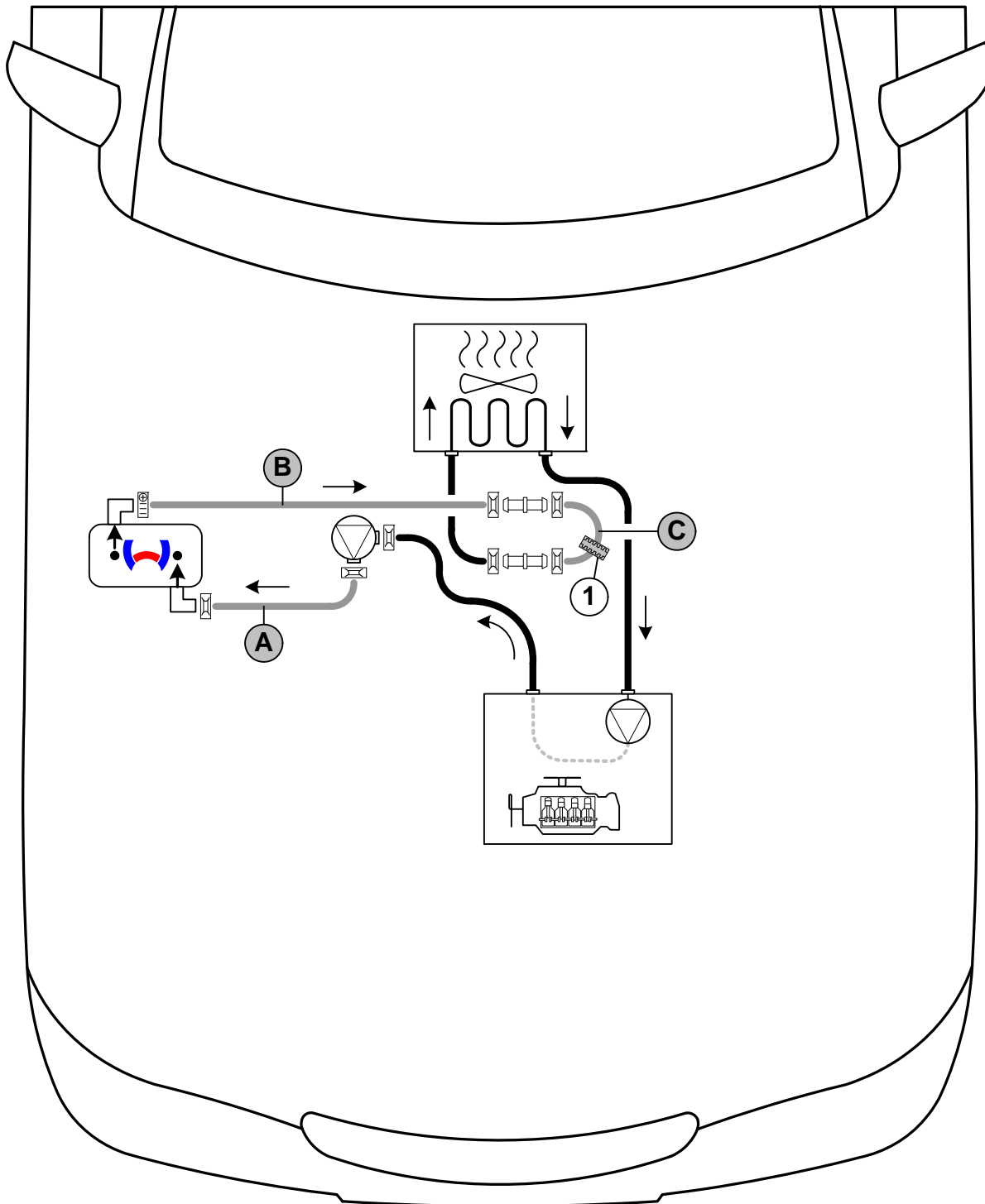

Any coolant running off should be collected in an appropriate container. Route hoses kink-free. Unless specified otherwise, always fasten using cable ties. Position clamps so that other hoses cannot be damaged. The heater must be filled with coolant when installing the hoses.

The connection should be modelled on an 'inline' circuit and based on the following diagram:



Hose routing diagram

All spring clips =  25 mm dia. Hose clamp  = 20-27 mm dia.
 All connecting pipes  = 18x18 mm dia.
 1 = Black (sw) rubber isolator 



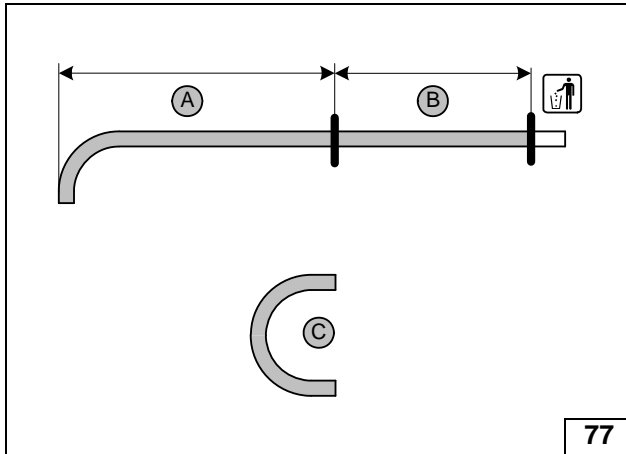

	1.0l	1.5l
A	260	260
B	225	210
C	180°, 18mm dia.	180°, 18mm dia.

Cutting hoses to length

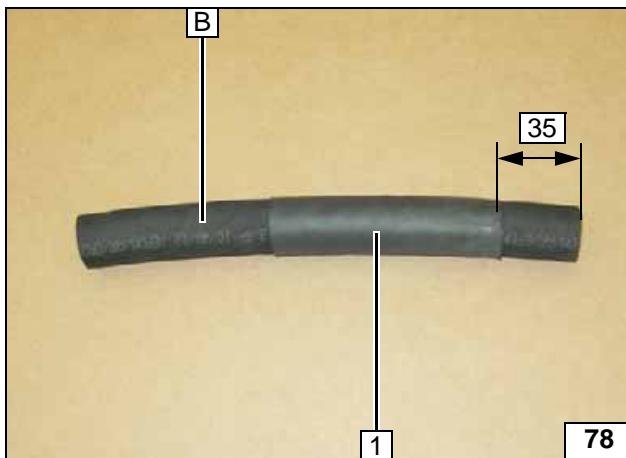

1 100 mm long heat shrink plastic tubing

Preparing Hose B

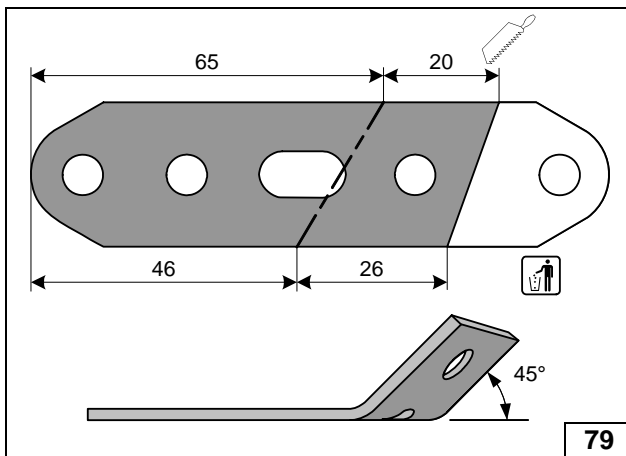

Cutting to length and bending perforated bracket

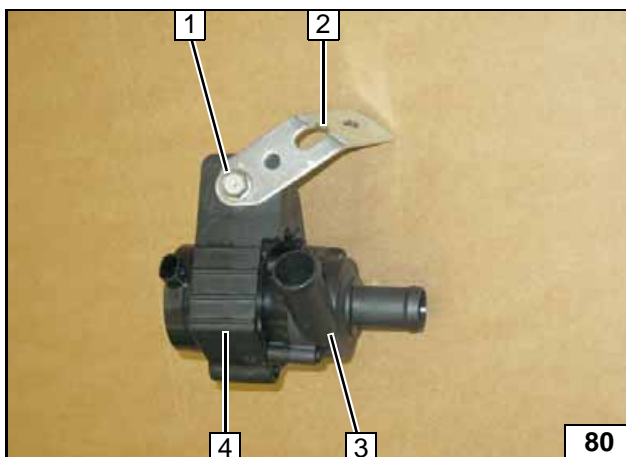

- 1 M6x25 bolt, flanged nut
- 2 Perforated bracket
- 3 Circulating pump
- 4 Circulating pump mount

Premounting circulating pump

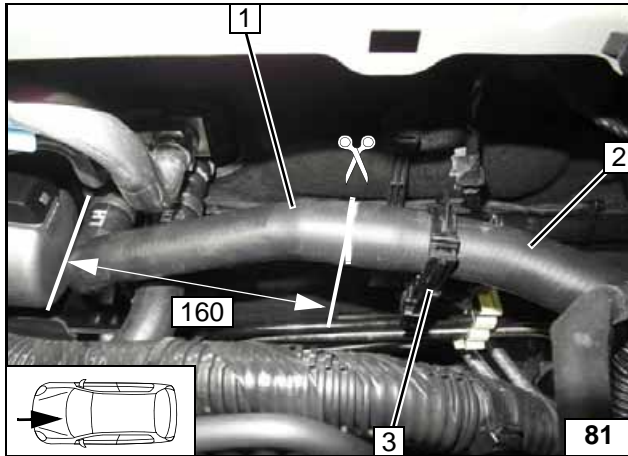
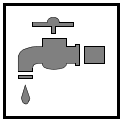

All 1.0

The following work is demonstrated on the 1,0 EcoBoost 92kW, but applies to all vehicles.

Open lock of original vehicle hose bracket 3, will be relocked later.

- 1 Heat exchanger inlet hose section
- 2 Engine outlet hose section

Cutting point

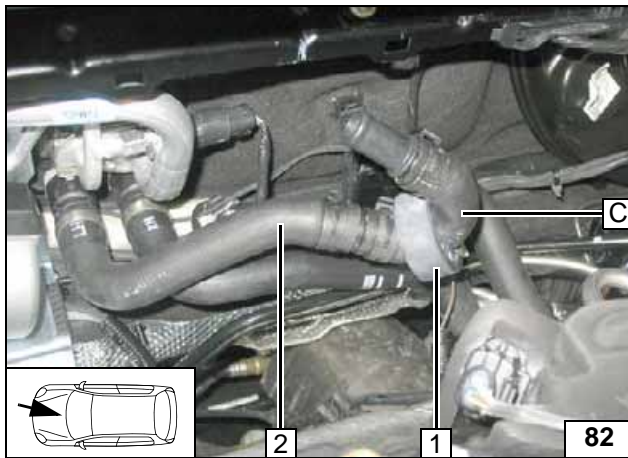

- 1 Black (sw) rubber isolator
- 2 Heat exchanger inlet hose section

**Connect-
ing heat ex-
changer
inlet**

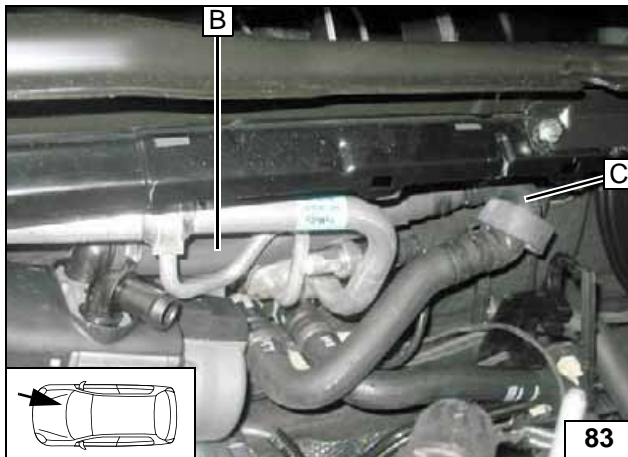

**Connect-
ing heater
outlet**

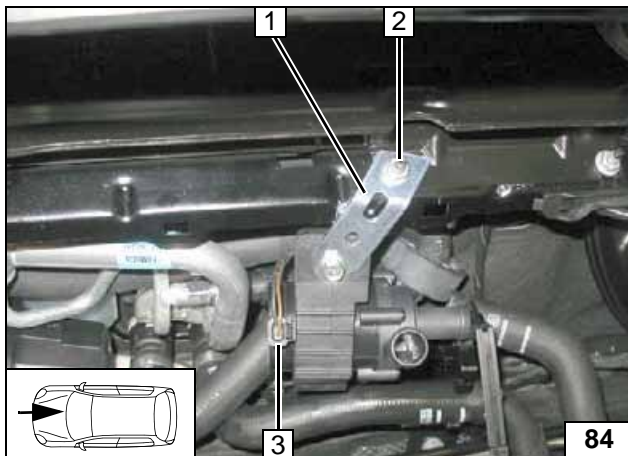

- 1 Perforated bracket
- 2 Original vehicle stud bolt, with nut
- 3 Install circulating pump wiring har-
ness

**Installing
circulating
pump**

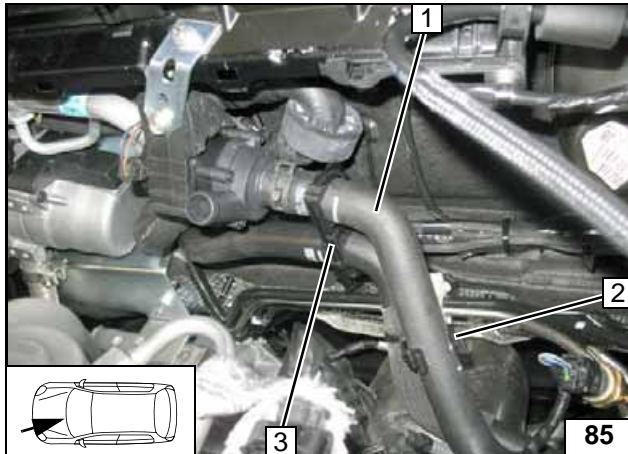

- 1 Engine outlet hose section
- 2 Hose bracket
- 3 Close lock of hose bracket (if present)

Connect-
ing engine
outlet

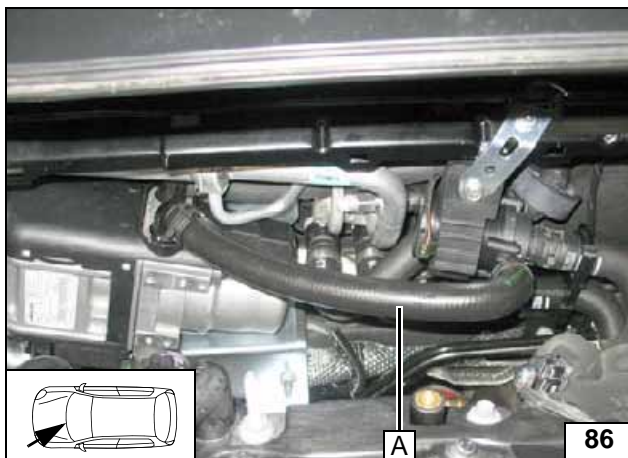

Align hoses.
Ensure sufficient distance from neighbour-
ing components.



Connect-
ing heater
inlet

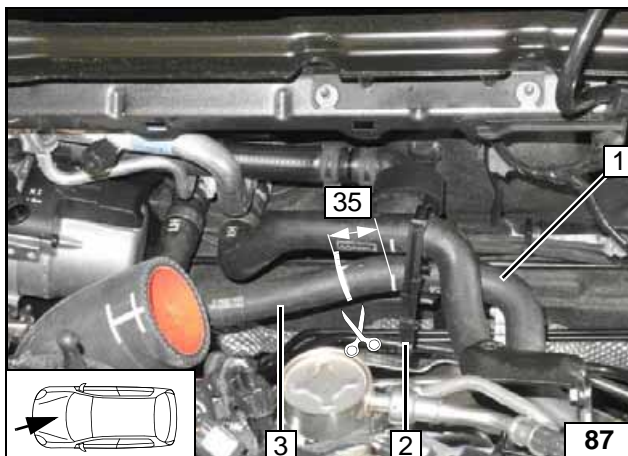

Focus 1.5 Engine Code M9DB

Open lock of original vehicle hose bracket
2.

- 1 Engine outlet hose section
- 3 Heat exchanger inlet hose section



Cutting
point

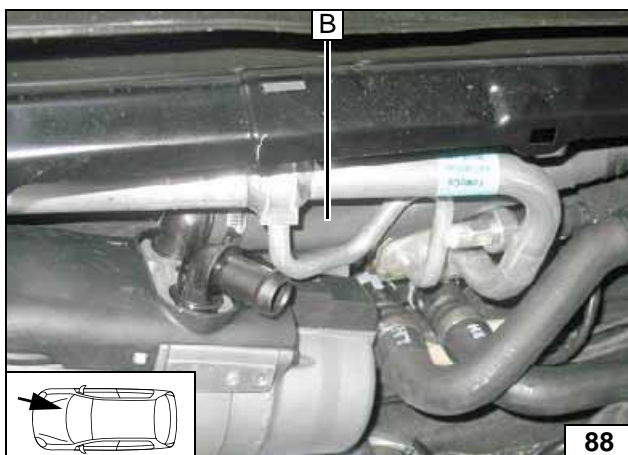

Connect-
ing heater
outlet

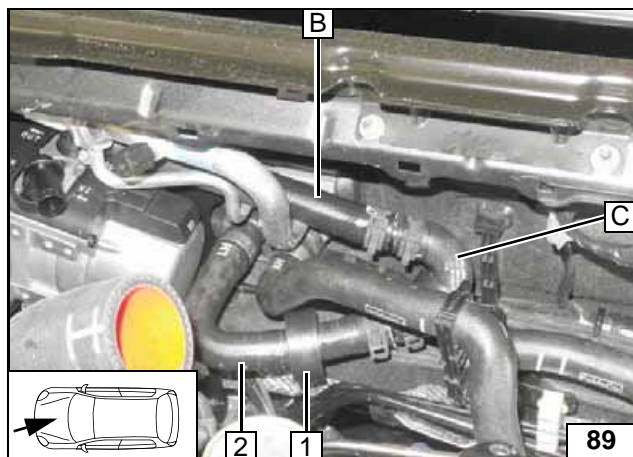

- 1 Black (sw) rubber isolator
- 2 Heat exchanger inlet hose section

Connect-
ing heat ex-
changer
inlet

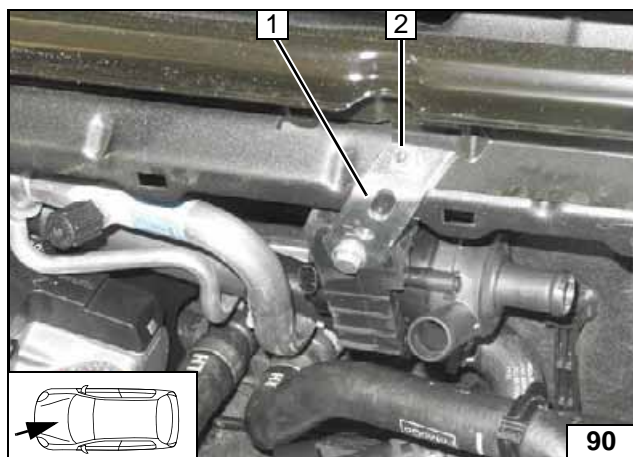

- 1 Perforated bracket
- 2 Original vehicle stud bolt and nut

Install-
ing circula-
ting
pump



- 1 Engine outlet hose section
- 2 Connector of circulating pump wiring harness

Connect-
ing engine
outlet

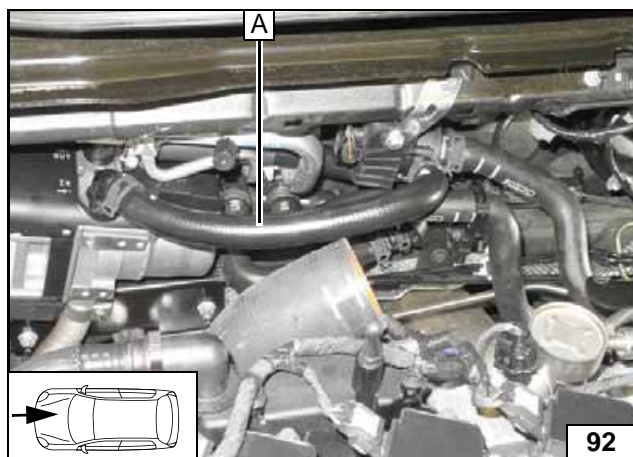

Connect-
ing heater
inlet

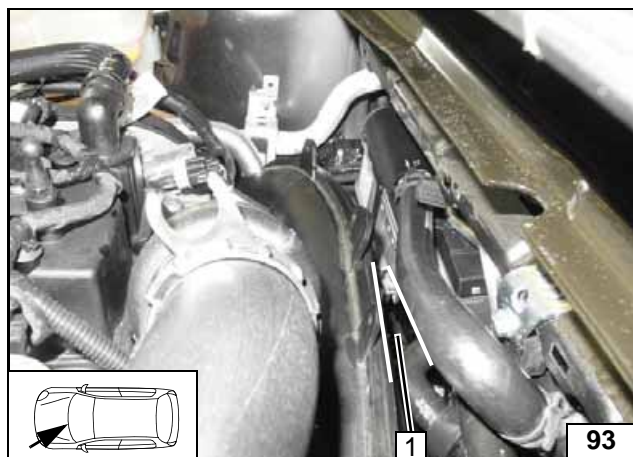

Align hoses.
Ensure sufficient distance from charge-air
tube at position 1.



**Aligning
hoses**

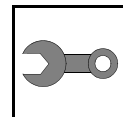

Final Work



Reassemble the components in reverse order. Check all hoses, clamps and all electrical connections for firm seating. Insulate and tie back loose lines. Only use manufacturer-approved coolant. Spray the heater components with anti-corrosion wax (Tectyl 100K).

- **Connect the battery.**
- **Fill and bleed the coolant circuit according to the vehicle manufacturer's instructions.**
- **Program MultiControl CAR, teach Telestart transmitter.**
- **Manual air-conditioning:**
Make settings on the A/C control panel according to the 'operating instructions'.
- **Automatic air-conditioning:**
If the fan function or A/C control panel settings need to be checked, see the installation documentation in the additional kit 'Webasto Standard' or 'Webasto Comfort' A/C control, section 'Final Work'.
- **Place the 'Switch off parking heater before refuelling' caution label near the filler neck.**
- **For initial startup and function check, please see installation instructions.**



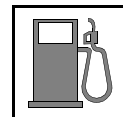

FuelFix Template

Top view

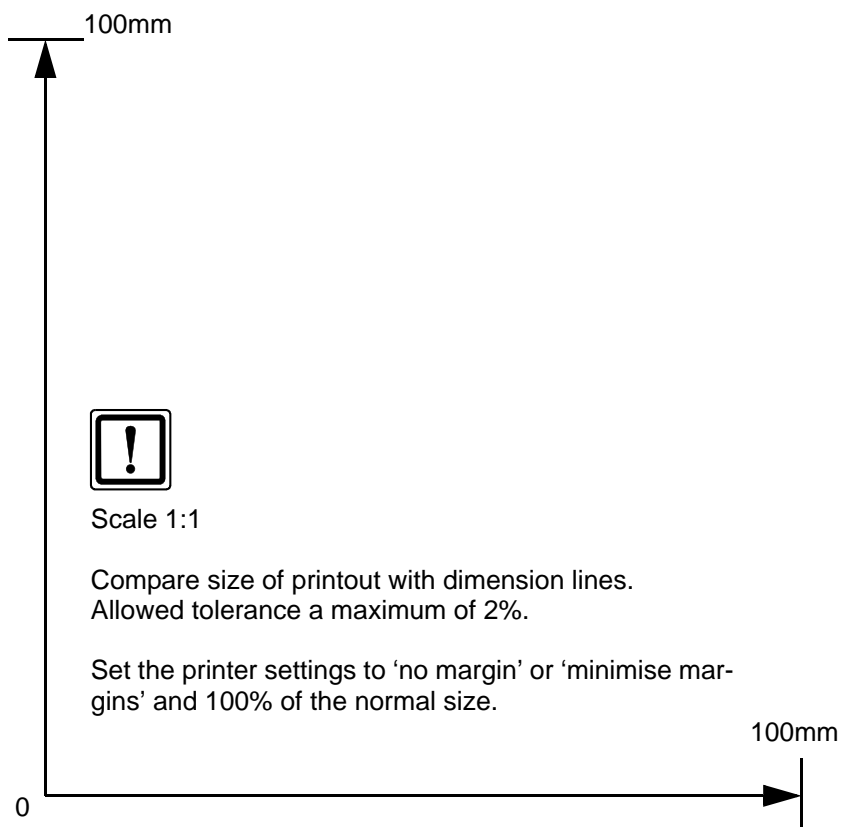
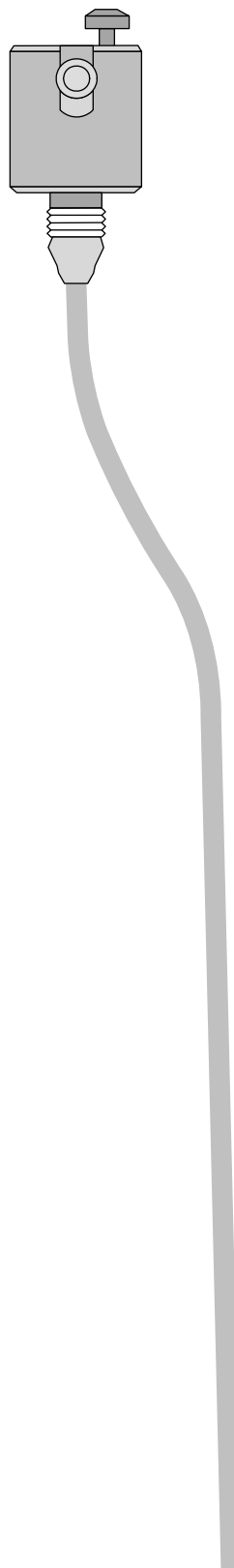
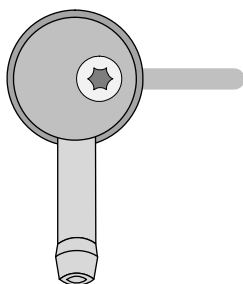

Operating Instructions for Focus with Man. A/C

Please remove page and add to the vehicle operating instructions.

Note:

We recommend matching the heating time to the driving time.

Heating time = driving time

Example:

For a driving time of approx. 20 min. (in one direction), we recommend not exceeding a switch-on time of 20 min.

Passenger compartment monitoring, if installed, must be deactivated in addition to the vehicle settings for the heating operation.

For instructions on deactivation, please refer to the operating instructions of the vehicle.

Before parking the vehicle, make the following settings:

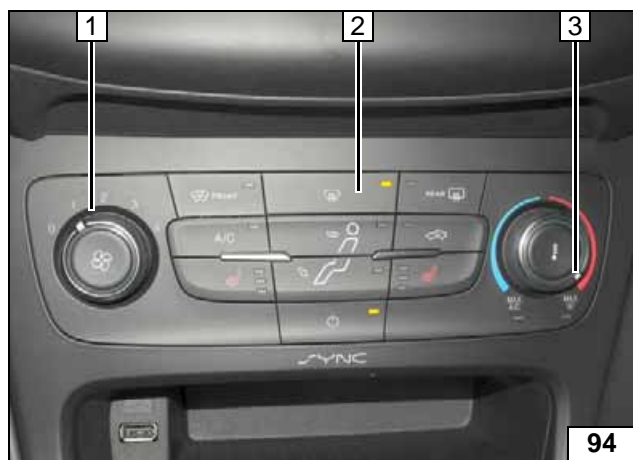

- 1 Set fan to level '1', or max. '2'
- 2 Air outlet to windscreen
- 3 Set temperature to 'max.'

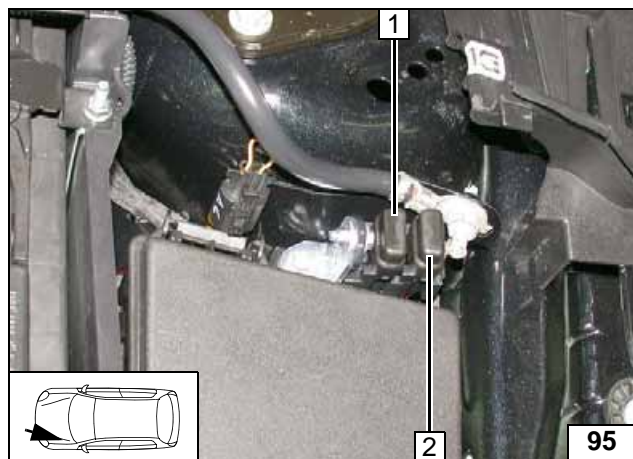

- 1 30A passenger compartment main fuse F2
- 2 20A heater fuse F1

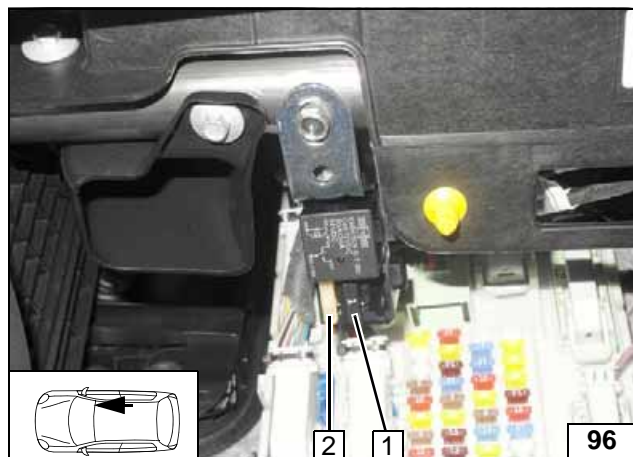

- 1 1A heater control fuse F3
- 2 25A fan fuse F4



A/C control panel for manual air-conditioning

Engine compartment fuses

Passenger compartment fuses

Operating Instructions for C-Max / Grand C-Max with Man. A/C

Please remove page and add to the vehicle operating instructions.

Note:

We recommend matching the heating time to the driving time.

Heating time = driving time

Example:

For a driving time of approx. 20 min. (in one direction), we recommend not exceeding a switch-on time of 20 min.

Passenger compartment monitoring, if installed, must be deactivated in addition to the vehicle settings for the heating operation.

For instructions on deactivation, please refer to the operating instructions of the vehicle.

Before parking the vehicle, make the following settings:

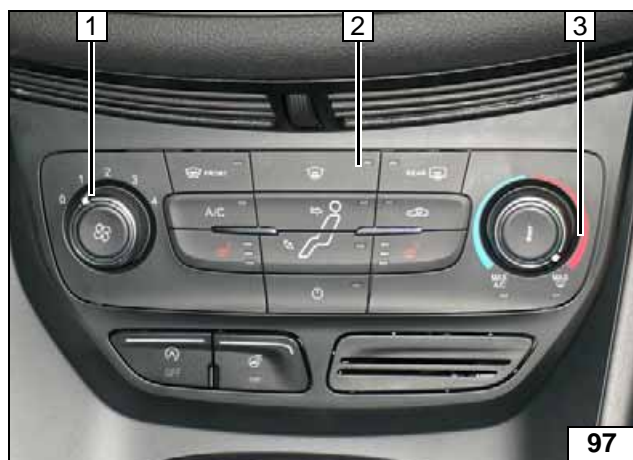

- 1 Set fan to level '1', or max. '2'
- 2 Air outlet to windscreen
- 3 Set temperature to 'max.'

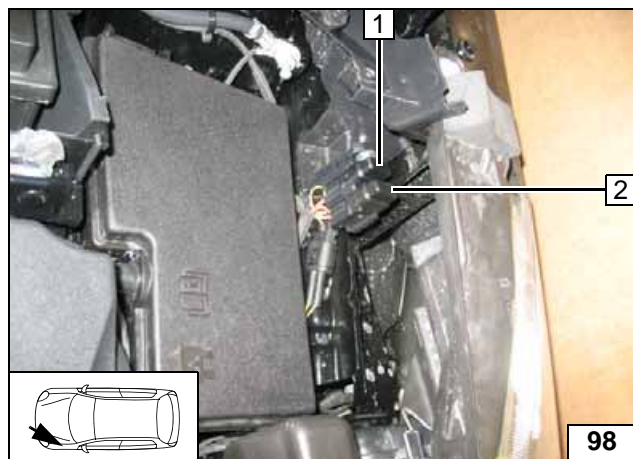

- 1 30A passenger compartment main fuse F2
- 2 20A heater fuse F1

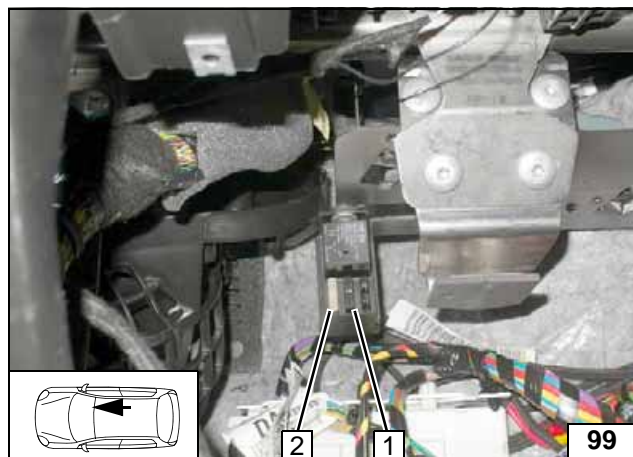

- 1 1A heater control fuse F3
- 2 25A fan fuse F4



A/C control panel for manual air-conditioning

Engine compartment fuses

Passenger compartment fuses

