

Water heater

Thermo Top Evo parking heater



Upgrade documentation VW T6 / Amarok 2

Validity

Manufacturer	Model	Type	Model year	EG BE No. / ABE
VW	T6	7HC	From model year 2015	e1 * 2001 / 116 * 0220
VW	Amarok 2	2HZ	From model year 2016	e1 * 2007 / 46 * 0356

From model year 2016

Left-hand drive vehicle

Verified equipment variants: Diesel
Climatronic
Vehicle with factory installed Webasto auxiliary heater

Not verified: Passenger compartment monitoring

Total installation time: approx. 2.5 hours

VW T6 / Amarok 2

Table of contents

Validity	1	Operation indicator option for T6	16
Necessary components	2	ThermoCall Option for T6	16
Installation overview	2	Fan Controller for Amarok	18
Information on total installation time	2	System wiring diagram for Amarok	19
Information on operating and installation instructions	3	Power supply connection for Amarok	20
Information on validity	4	MultiControl CAR option for Amarok	23
Technical information	4	Remote option (Telestart) for Amarok	23
Explanatory notes on document	4	Operation indicator option for Amarok	24
Preliminary work	5	ThermoCall option for Amarok	25
Fan controller for T6	6	Final work	26
Power supply connection for T6	7	Loading the upgrade software	27
System wiring diagram for T6, version 1	8	Operating instructions for Climatronic on T6	28
Connection for T6 with version 1	9	Operating instructions for Climatronic on Amarok	29
System wiring diagram for T6, version 2	11		
Connection for T6 with version 2	12		
Heater connection for T6 in case of version 2	13		
MultiControl CAR option for T6	15		
Remote option (Telestart) for T6	15		

Necessary components

- Upgrade kit for VW T6 / Amarok 2 2016 Diesel Climatronic: **1324103B**
- Control element in accordance with price list and upon consultation with end customer
- In case of installation of MultiControl CAR: MultiControl installation frame: **9030077_**
- In case of Telestart option, indicator lamp in accordance with price list and in consultation with end customer

Installation instructions:

- The installation location of the push button in case of Telestart or ThermoCall should be confirmed with the end customer.
- Depending on the space required and the vehicle manufacturer's instructions, we recommend the use of a vehicle battery with a higher electrical capacity.

Installation overview

Legend:

1. OE heater for T6
2. OE heater for Amarok 2
3. Fuse holder in passenger compartment
4. Control element connector

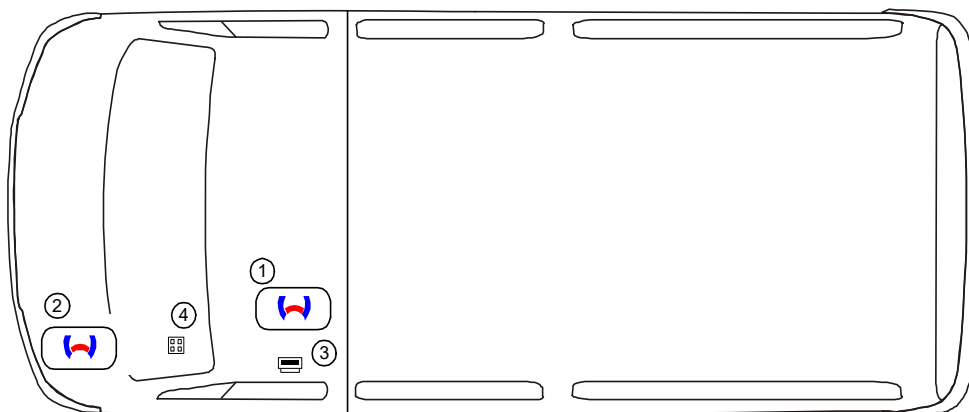

Information on total installation time

The total installation time includes the time needed for mounting and demounting the vehicle-specific components, the heater specific installation time and all other times required for the system integration and initial start-up of the heater. The total installation time may vary for vehicle equipment other than provided.

Information on operating and installation instructions

1 Important information (not complete)

1.1 Installation and repair



The improper installation or repair of Webasto heating and cooling systems can cause fire or the leakage of deadly carbon monoxide, leading to serious injury or death.



To install and repair Webasto heating and cooling systems you need to have completed a special company training course and have the appropriate technical documentation, special tools and special equipment.



Installation and repair may ONLY be carried out by persons trained and certified in a Webasto training course. NEVER try to install or repair Webasto heating or cooling systems if you have not completed a Webasto training course, you do not have the necessary technical skills and you do not have the technical documentation, tools and equipment available to ensure that you can complete the installation and repair work properly.

Only use genuine Webasto parts. See the Webasto air and water heaters accessories catalogue for this purpose.

1.2 Operation

To ensure safe operation, we recommend having the heater checked every two years by an authorised Webasto dealer, especially when used over a long period and/or under extreme environmental conditions.

Do not operate the heater in closed rooms due to the danger of poisoning and suffocation.

Always switch off the heater before refuelling.

The heater may only be used with the prescribed fuel diesel (DIN EN 590) or petrol (DIN EN 228).

The heater may not be cleaned with a high-pressure cleaner.

1.3 Please note

ALWAYS follow all Webasto installation and operating instructions and observe all warnings.

To become familiar with and understand all functions and properties of the heater, the operating instructions must be read carefully and observed at all times.

For proper, safe installation and repair work, the installation instructions with all warnings and safety information must be carefully read and observed at all times. Please always contact a workshop authorised by Webasto for all installation and repair work.

Important

Webasto shall assume no liability for defects, damage and injuries resulting from a failure to observe the installation, repair and operating instructions of the information contained in them.

This liability exclusion particularly applies to improper installations and repairs, installations and repairs by untrained persons or in the case of a failure to use genuine spare parts.

The liability due to culpable disregard to life, limb or health and due to damage or injuries caused by a wilful or reckless breach of duty remain unaffected, as does the obligatory product liability.

Installation should be carried out according to the general, standard rules of technology. Unless specified otherwise, fasten hoses, lines and wiring harnesses to original vehicle lines and wiring harnesses using cable ties. Insulate loose wire ends and tie back. Connectors on electronic components must audibly snap into place during assembly.

Sharp edges should be fitted with rub protection. Spray unfinished body areas, e.g. drilled holes, with anti-corrosion wax (Tectyl 100K).

Observe the instructions and guidelines of the respective vehicle manufacturer for demounting and mounting vehicle specific components!

The initial start-up is to be executed with the Webasto Thermo Test Diagnosis.

When installing a programmable control module (e.g. a PWM Gateway), the corresponding settings must be checked or adjusted.

2 Statutory regulations governing installation

Guidelines	Thermo Top Evo
Heating Directive ECE R122	E1 00 0258
EMC Directive ECE R10	E1 04 5627

Note

The regulations of these guidelines are binding in the scope of the Directive 70/156/EEC and/or 2007/46/EC (for new vehicle models from 29/04/2009) and should also be observed in countries in which there are no special regulations.

Important

Failure to follow the installation instructions will result in the invalidation of the type approval for the heater and therefore invalidation of the general **homologation of the vehicle**.

Note

The heater is licensed in accordance with paragraph 19, section 3, No. 2b of the StVZO (German Road Traffic Licensing Authority).

2.1 Excerpt from ECE regulation 122 (heating system) paragraph 5 for the installation of the heater

Beginning of excerpt.

ANNEX VII

REQUIREMENTS FOR COMBUSTION HEATERS AND THEIR INSTALLATION

1. GENERAL REQUIREMENTS

1.7.1. A clearly visible tell-tale in the operator's field of view shall inform when the combustion heater is switched on or off.

2. VEHICLE INSTALLATION REQUIREMENTS

2.1. Scope

2.1.1. Subject to paragraph 2.1.2, combustion heaters shall be installed according to the requirements of this Annex.

2.1.2. Vehicles of category O having liquid fuel heaters are deemed to comply with the requirements of this Annex.

2.2. Positioning of heater

2.2.1. Body sections and any other components in the vicinity of the heater must be protected from excessive heat and the possibility of fuel or oil contamination.

2.2.2. The combustion heater shall not constitute a risk of fire, even in the case of overheating. This requirement shall be deemed to be fulfilled if the installation ensures an adequate distance to all parts and suitable ventilation, by the use of fire resistant materials or by the use of heat shields.

2.2.3. In the case of M2 and M3 vehicles, the heater must not be positioned in the passenger compartment. However, an installation in an effectively sealed envelope which also complies with the conditions in paragraph 2.2.2 may be used.

2.2.4. The label referred to in paragraph 1.4 or a duplicate, must be positioned so that it can be easily read when the heater is installed in the vehicle.

2.2.5. Every reasonable precaution should be taken in positioning the heater to minimise the risk of injury and damage to personal property.

2.3. Fuel supply

2.3.1. The fuel filler must not be situated in the passenger compartment and must be provided with an effective cap to prevent fuel spillage.

2.3.2. In the case of liquid fuel heaters, where a supply separate to that of the vehicle is provided, the type of fuel and its filler point must be clearly labelled.

2.3.3. A notice, indicating that the heater must be shut down before refuelling, must be affixed to the fuelling point. In addition a suitable instruction must be included in the manufacturer's operating manual.

2.4. Exhaust system

2.4.1. The exhaust outlet must be located so as to prevent emissions from entering the vehicle through ventilators, heated air inlets or opening windows.

2.5. Combustion air inlet

2.5.1. The air for the combustion chamber of the heater must not be drawn from the passenger compartment of the vehicle.

2.5.2. The air inlet must be so positioned or guarded that blocking by rubbish or luggage is unlikely.

2.6. Heating air inlet

2.6.1. The heating air supply may be fresh or recirculated air and must be drawn from a clean area not likely to be contaminated by exhaust fumes emitted either by the propulsion engine, the combustion heater or any other vehicle source.

2.6.2. The inlet duct must be protected by mesh or other suitable means.

2.7. Heating air outlet

2.7.1. Any ducting used to route the hot air through the vehicle must be so positioned or protected that no injury or damage could be caused if it were to be touched.

2.7.2. The air outlet must be so positioned or guarded that blocking by rubbish or luggage is unlikely.

End of excerpt.

In multilingual versions the German language is binding.

Information on validity

This upgrade documentation applies to VW T6 Diesel vehicles from model year 2015 and later as well as VW Amarok 2 diesel vehicles from model year 2016 and later - for validity, see page 1- assuming technical modifications to the vehicle do not affect installation, any liability claims excluded. Depending on the vehicle version and equipment, modifications may be necessary during installation with respect to this installation documentation.

Vehicle and engine types, equipment variants and other specifications not listed in this installation documentation have not been tested. However, installation according to this installation documentation may be possible.

Technical information

Special tools

- Automatic wire stripper, 0.2 - 6mm²
- Crimping pliers for male connector, 0.14 - 6mm²
- Crimping pliers for cable lug, 0.5 - 10mm²
- Crimping pliers for connector, 0.25 - 6mm²
- Torque wrench for 2.0 - 10 Nm
- Deep-hole marker
- Webasto Thermo Test Diagnosis with current software

Dimensions

- All dimensions are in mm.

Tightening torque values

- Tighten original vehicle bolt connections in accordance with manufacturer's instructions or in accordance with state-of-the-art-technology.

Explanatory notes on document

You will find an identification mark on the outside top right corner of the page in question to provide you with a quick overview of the individual working steps.

Special features are highlighted using the following symbols:

Mechanical system



Electrical system



Specific risk of injury or fatal accidents.



Specific risk due to electrical voltage.



Specific risk of damage to components.



Specific risk of fire and explosion.



Reference to general installation instructions of the Webasto components or to the manufacturer's vehicle-specific documents.



Reference to a special technical feature.



The arrow in the vehicle icon indicates the position on the vehicle and the viewing angle.

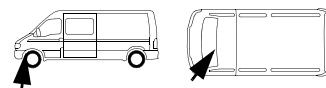

Tightening torque according to the manufacturer's vehicle-specific documents.



VW T6 / Amarok 2

Preliminary work

T6

- Disconnect the battery.
- Remove the footwell trim on the driver's side (if present).
- Remove the lower instrument panel trim on the driver's side.
- Remove the side step cover on the driver's side.
- Remove the driver's seat (4x bolts).

Amarok 2

- Disconnect and remove the battery.
- Remove the footwell trim on the driver's side (if present).
- Remove the lower instrument panel trim on the driver's side.
- Remove the external instrument panel trim on the left.



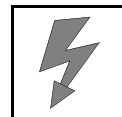

Fan controller for T6

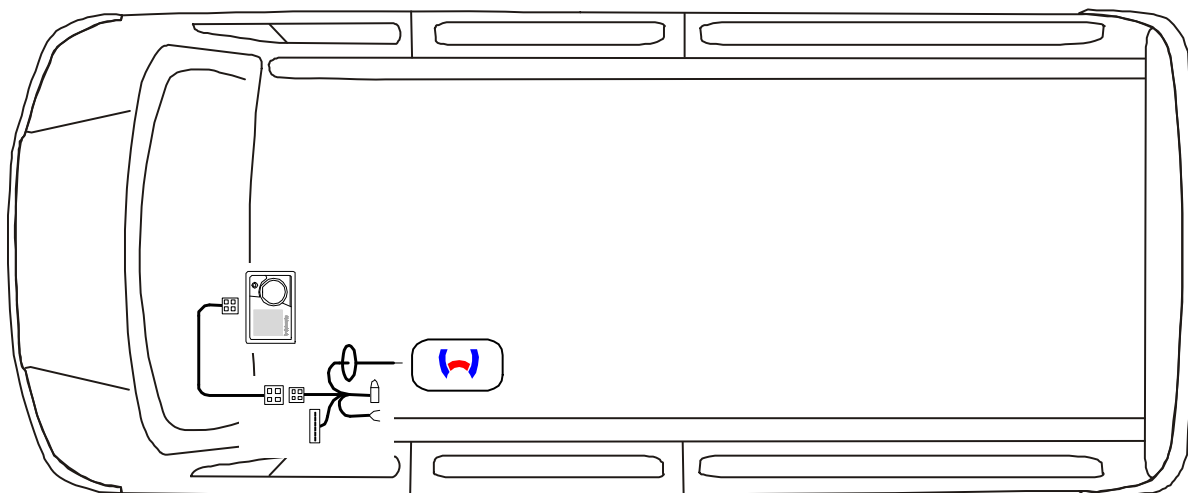

Wiring harness routing diagram

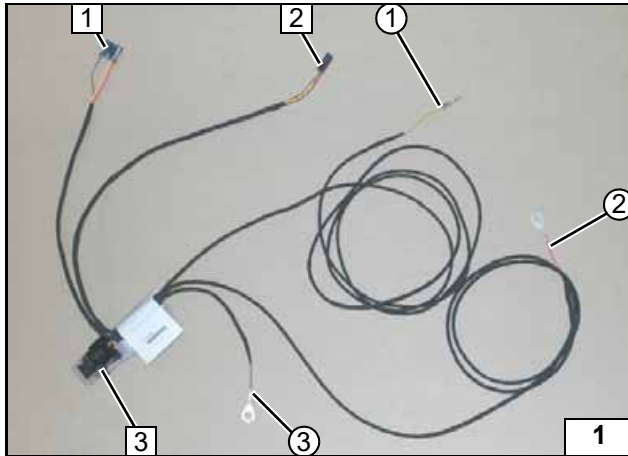

Power supply connection for T6

Wire sections retain their numbering in the entire document.

- 1 6-pin female connector (will not need)
- 2 4-pin female connector, control element connection via wiring harness extension
- 3 Fuse F1
- ① Yellow (ge) wire of signal line
- ② Red (rt) wire of positive connection
- ③ Brown (br) wire of earth connection



View of up-grade wiring harness

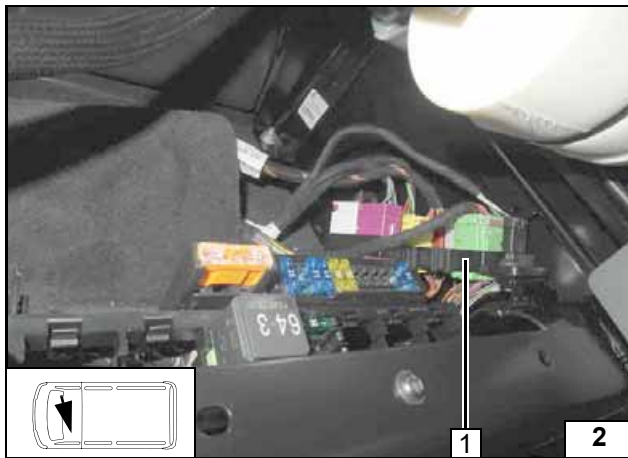

Produce all following electrical connections as shown in the system wiring diagram.

- 1 Plug connector under the driver's seat



Detaching plug connector

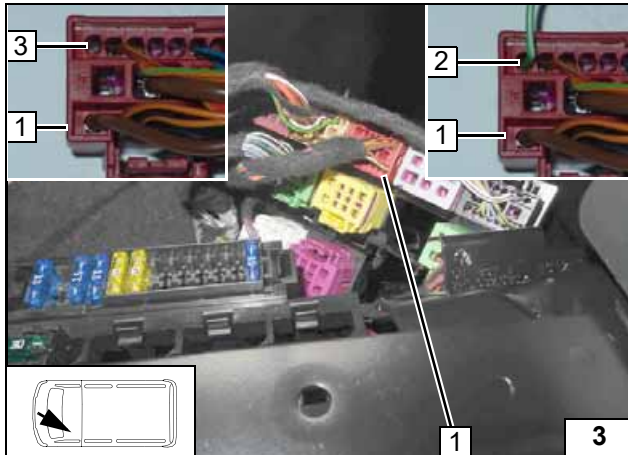

Detach 17-pin connector Xn 1. Check the assignment at pin 1!
2 versions are possible.

- 2 **Version 1** with 0.75² green/white (gn/ws) wire
- 3 **Version 2** without 0.75² green/white (gn/ws) wire



Disconnecting connector Xn / checking pin assignment / identifying versions

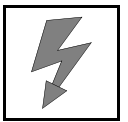

System wiring diagram for T6, version 1



System wiring diagram for Climatronic

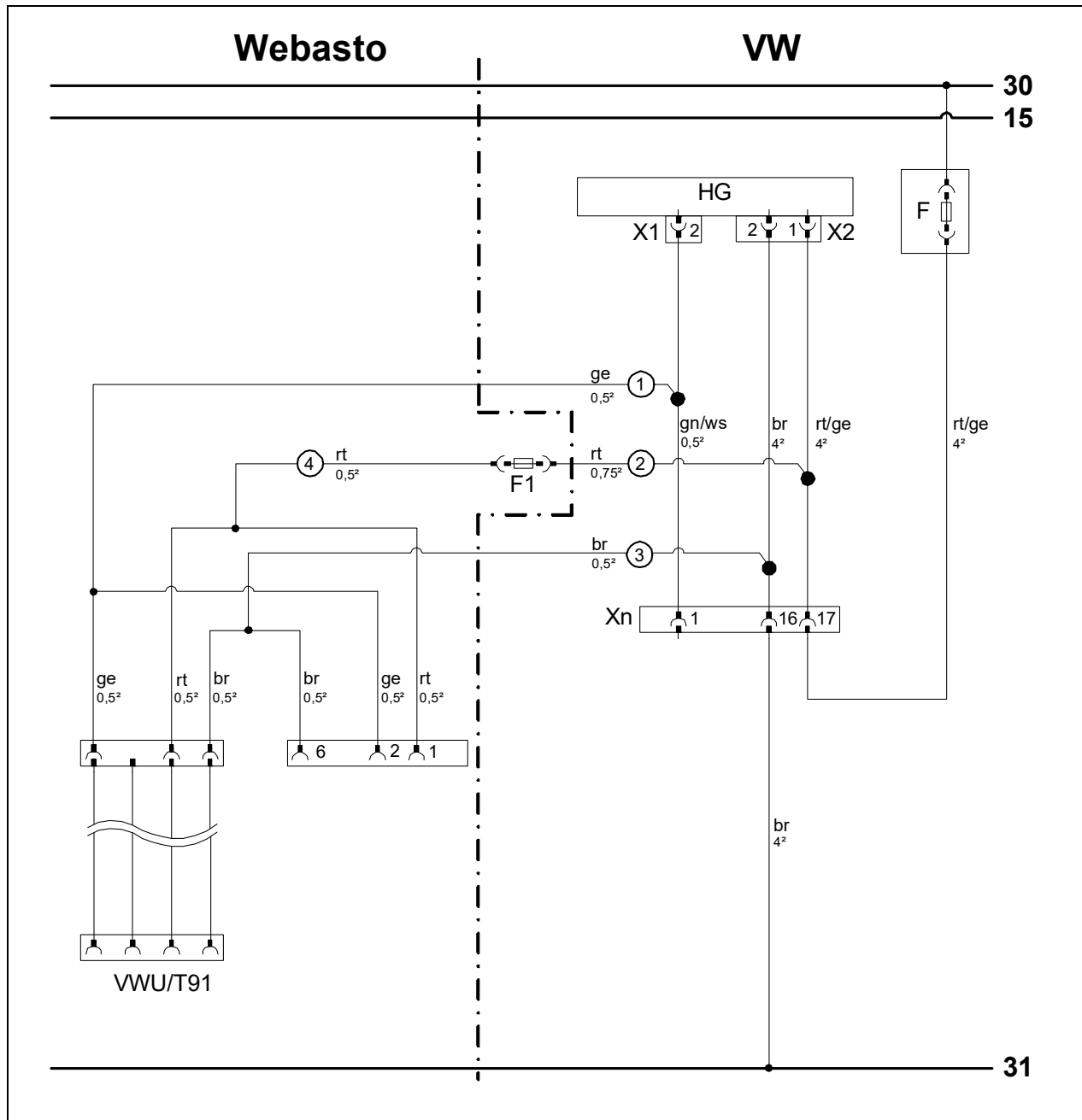

Webasto components		Vehicle components		Colours and symbols	
F1	1A fuse	F	Heater fuse	rt	red
VWU/T91	4-pin female connector of wiring harness extension for the connection of the digital timer or Telestart	HG	TT-Evo heater (OE)	ws	white
		X1	6-pin heater connector	ge	yellow
		X2	2-pin heater connector	br	brown
		Xn	17-pin connector	gn	green
Wiring colours may vary.					

Legend

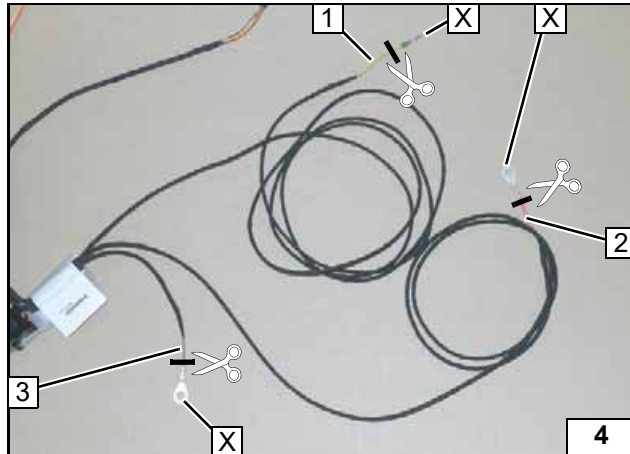
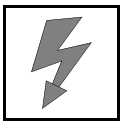

Connection for T6 with version 1

Cut off premounted cable lug on red (rt) wire 2 and brown (br) wire 3 as well as pre-mounted female connector on yellow (ge) wire 1 and discard.

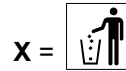

Preparing upgrade wiring harness

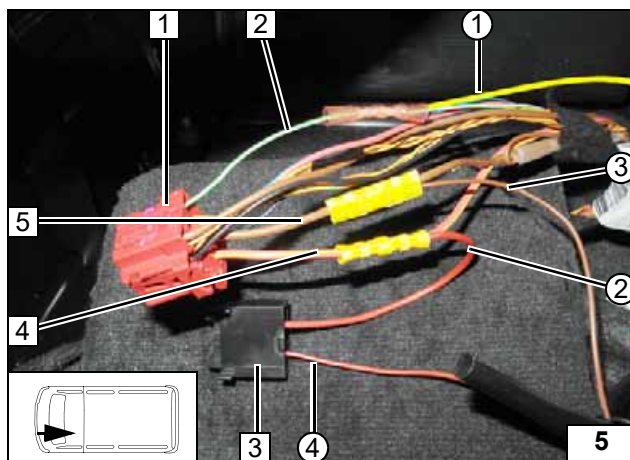

- 1 17-pin connector Xn
- 2 Green/white (gn/ws) wire of connector Xn/ pin 1
- 3 Upgrade wiring harness of fuse holder F1
- 4 Red/yellow (rt/ge) wire of connector Xn/ pin 17
- 5 Brown (br) wire of connector Xn/ pin 16
- ① Yellow (ge) wire of signal line/ upgrade wiring harness
- ② Red (rt) wire of positive supply/ upgrade wiring harness
- ③ Brown (br) wire of earth connection/ upgrade wiring harness

Connection to connector Xn



Reinstall connector Xn 1 and plug connector.

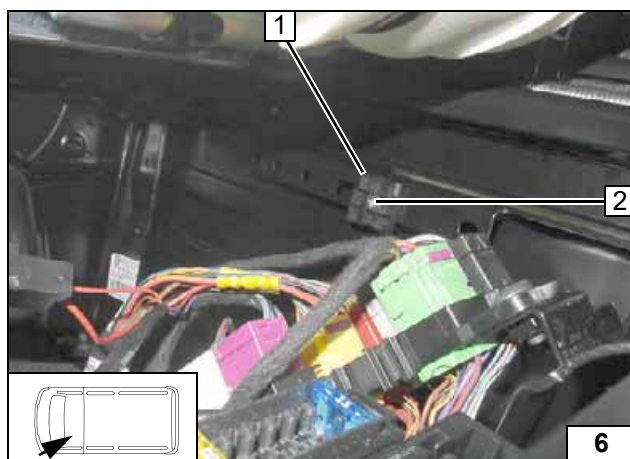

- 1 Fuse holder retaining plate
- 2 M4x16 countersunk head screw, existing hole, large diameter washer, nut

Mounting retaining plate

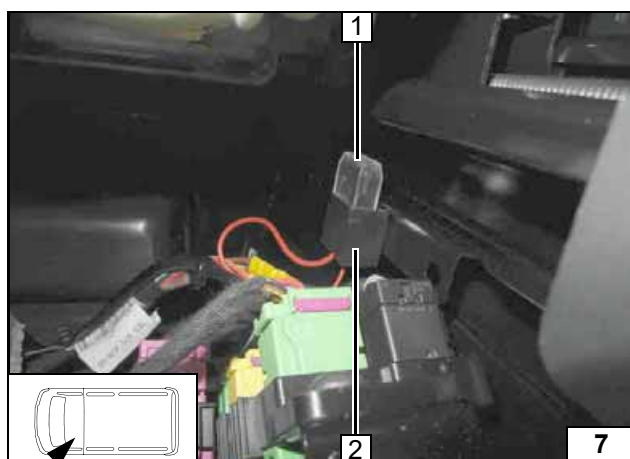

- 1 Protective cap, 1A fuse F1 mounted
- 2 Fuse holder

Installing fuse holder

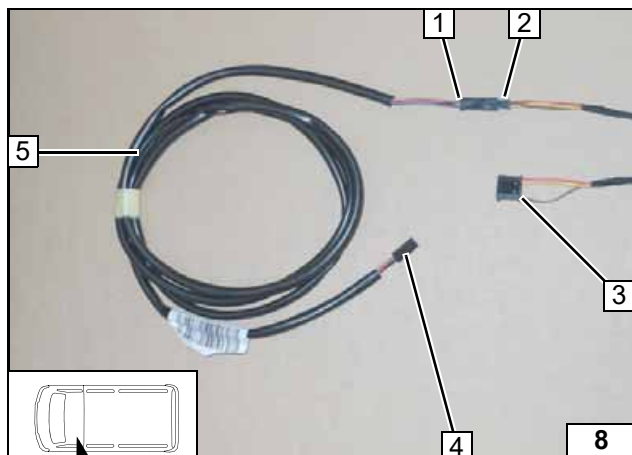

Routing wiring harness extension for T6

- 1 Male plug of wiring harness extension
- 2 4-pin female plug of upgrade wiring harness
- 3 6-pin female plug of upgrade wiring harness (will not be used)
- 4 Female plug of wiring harness extension for control element connection
- 5 Wiring harness extension



Connecting wiring harnesses

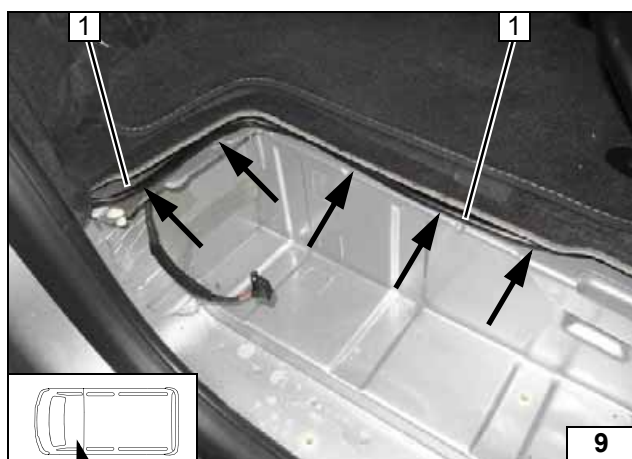

Route wiring harness extension 1 to the instrument panel as shown.



Routing wiring harness

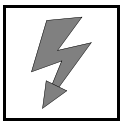

System wiring diagram for T6, version 2



System wiring diagram for Climatronic

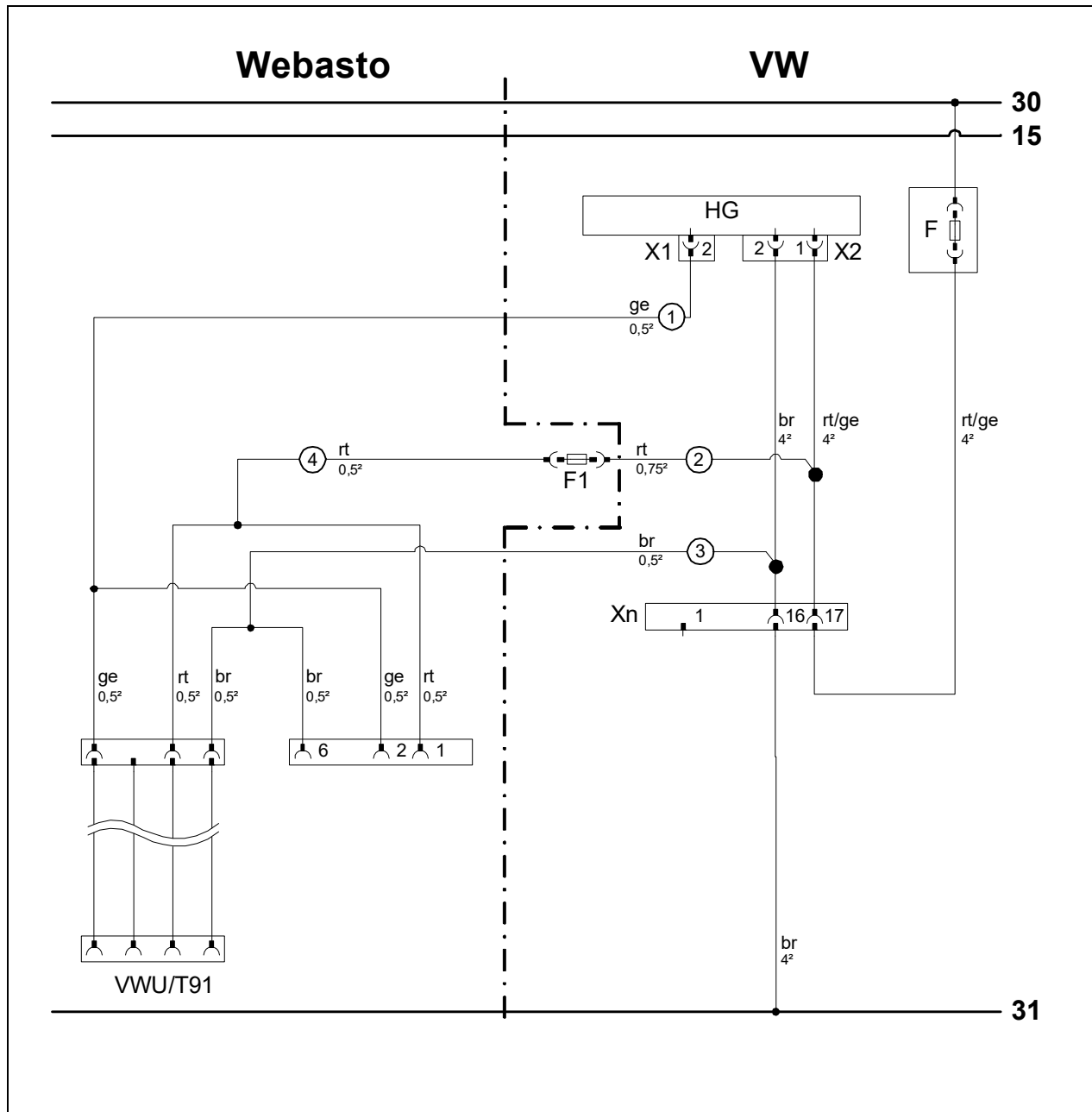

Webasto components		Vehicle components		Colours and symbols	
F1	1A fuse	F	Heater fuse	rt	red
VWU/T91	4-pin female connector of wiring harness extension for the connection of the digital timer or Telestart	HG	TT-Evo heater (OE)	ws	white
		X1	6-pin heater connector	ge	yellow
		X2	2-pin heater connector	br	brown
		Xn	17-pin connector	gn	green
				Wiring colours may vary.	

Legend

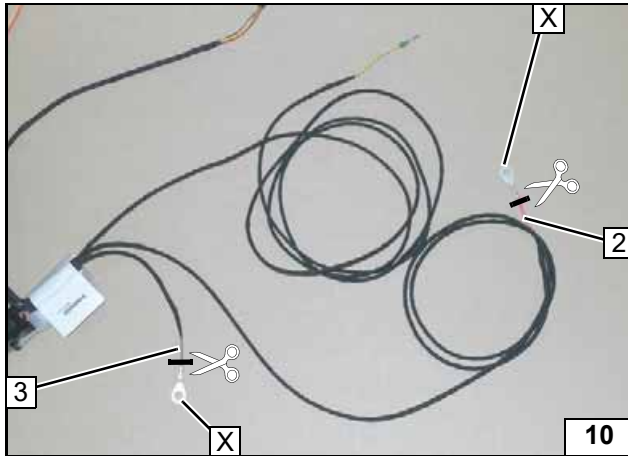
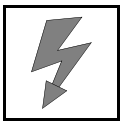

Connection for T6 with version 2

Cut off premounted cable lug on red (rt) wire 2 and brown (br) wire 3 and discard.

X =



Preparing upgrade wiring harness

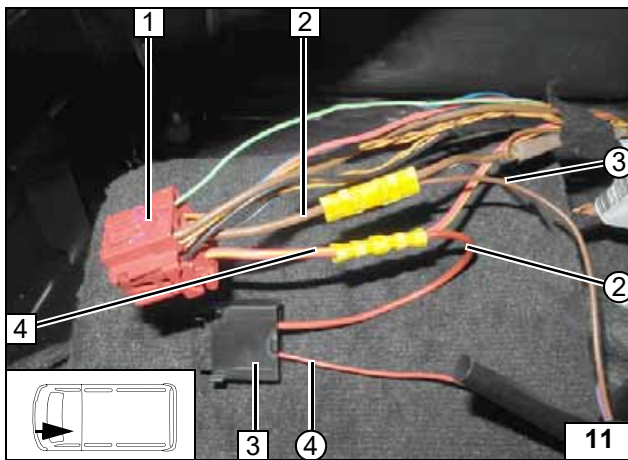

- 1 17-pin connector Xn
- 2 Brown (br) wire of connector Xn/ pin 16
- 3 Upgrade wiring harness fuse holder
- 4 Red/yellow (rt/ge) wire of connector Xn/ pin 17
- ② Red (rt) wire of positive supply/ upgrade wiring harness
- ③ Brown (br) wire of earth connection/ upgrade wiring harness



Connection to connector Xn

Reinstall connector Xn 1 and plug connector.

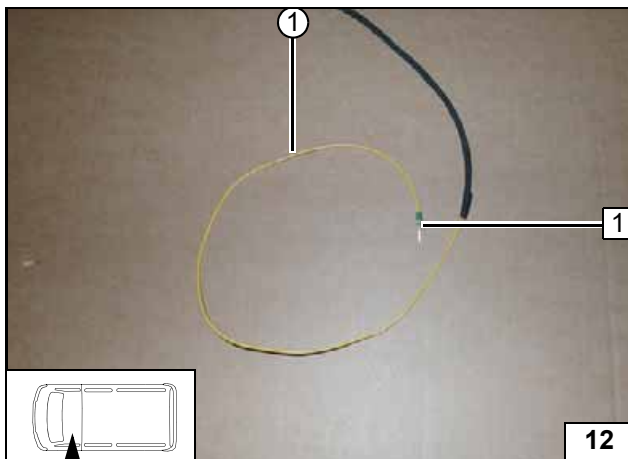

Route yellow (ge) wire ① of upgrade wiring harness through original vehicle wiring harness pass through to the heater as shown in the next figure.

- 1 Microtimer, premounted



Routing yellow (ge) wire ①

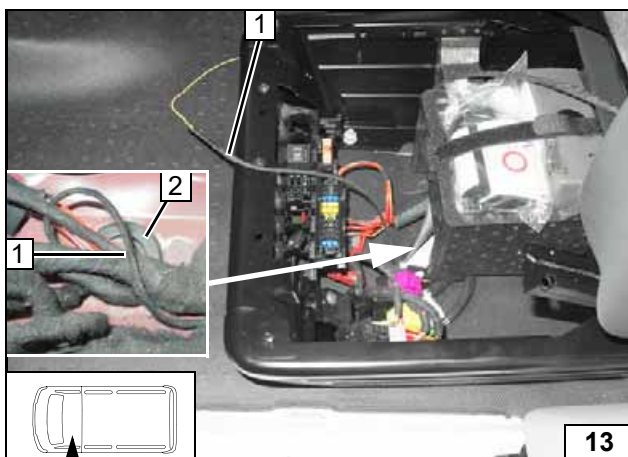

- 1 Yellow (ge) wire ① of upgrade wiring harness
- 2 Wiring harness pass through to underbody

Routing upgrade wiring harness to underbody

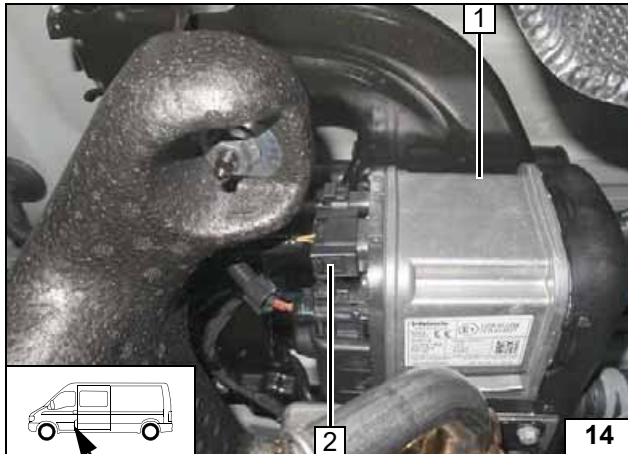
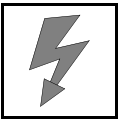

Heater connection for T6 in case of version 2

- 1 Heater
- 2 Pull off 6-pin heater connector X1

Pulling out heater connector

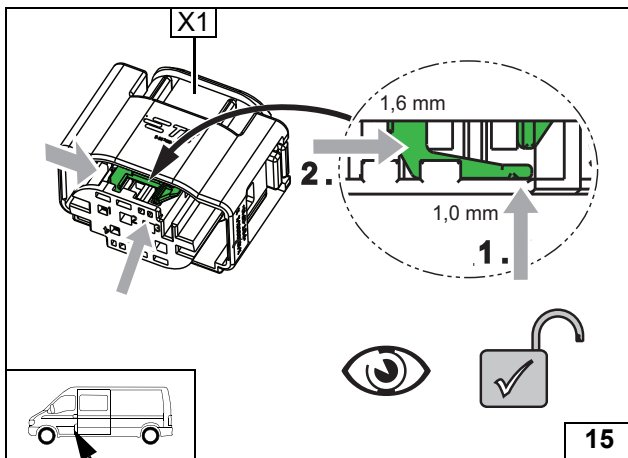

Release lock as shown!



Unlocking connector X1

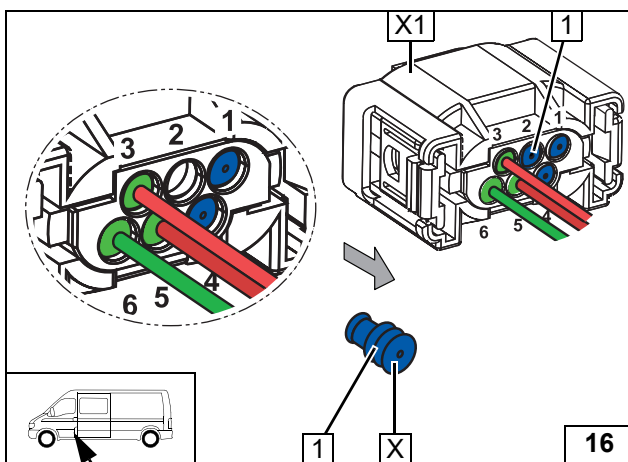

Remove blue (bl) sealing plug 1 from slot 2.



Removing sealing plug

X =

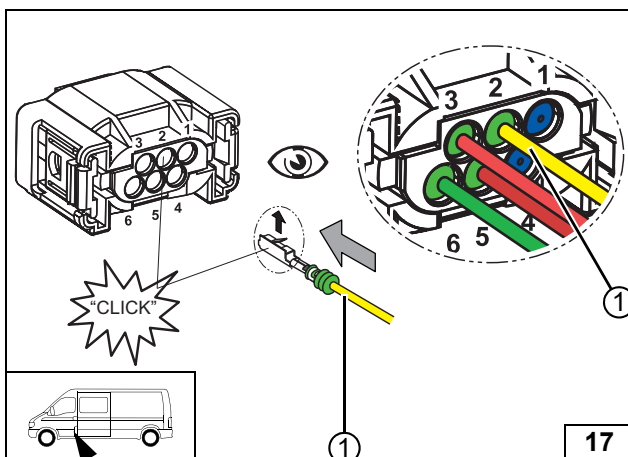

Insert yellow (ge) wire ① into slot 2.



Installing yellow (ge) wire

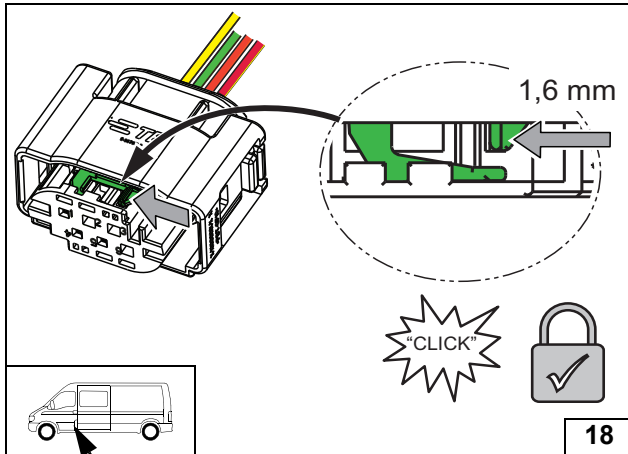

Locking connector X1

1 Heater wiring harness connector X1

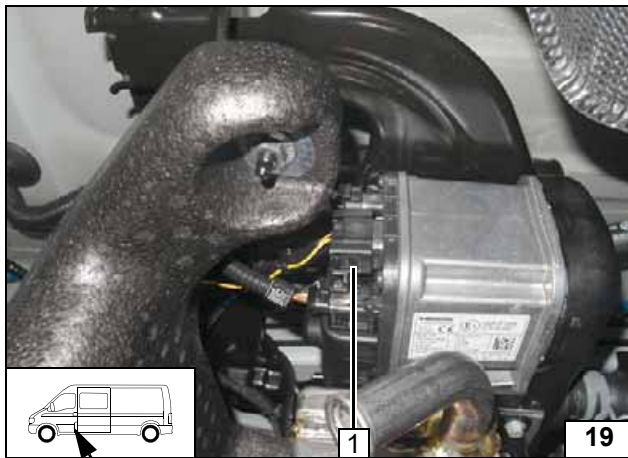

Installing heater connector X1

Routing wiring harness extension for T6

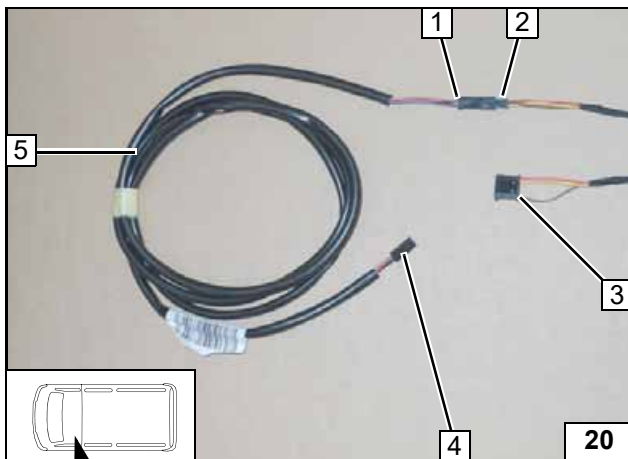

- 1 Male plug of wiring harness extension
- 2 4-pin female plug of upgrade wiring harness
- 3 6-pin female plug of upgrade wiring harness (will not be used)
- 4 Female plug of wiring harness extension for control element connection
- 5 Wiring harness extension

Connecting wiring harnesses

Route wiring harness extension 1 to the instrument panel as shown.

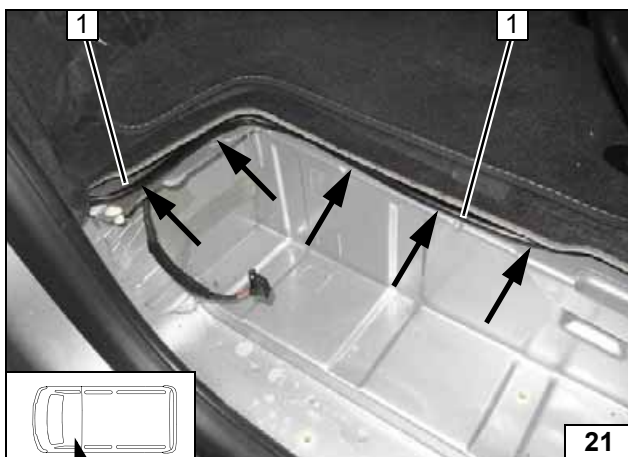

Routing wiring harness

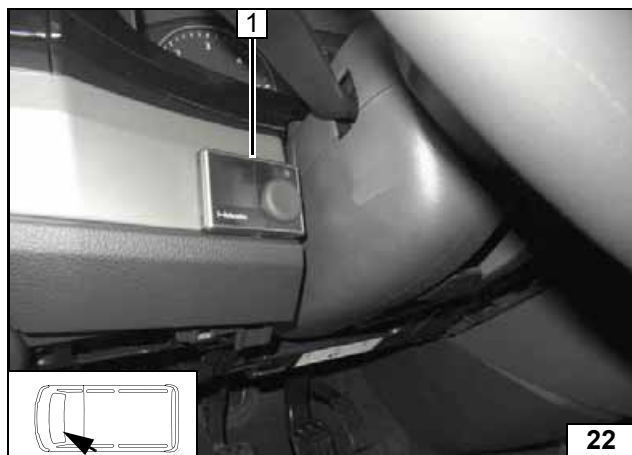

MultiControl CAR option for T6

1 Installation frame (optional)



Installing MultiControl CAR

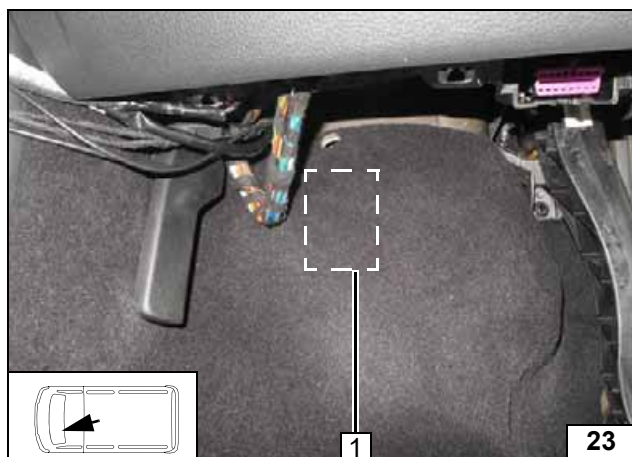

Remote option (Telestart) for T6

Fasten receiver 1 with double-sided adhesive tape behind the mat.



Installing receiver

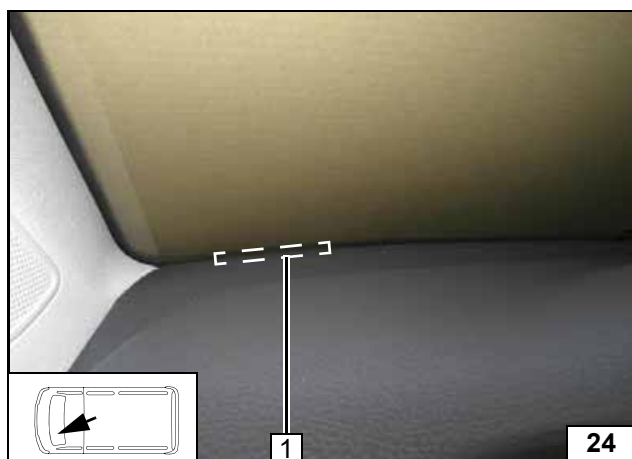

1 Aerial

Mounting aerial

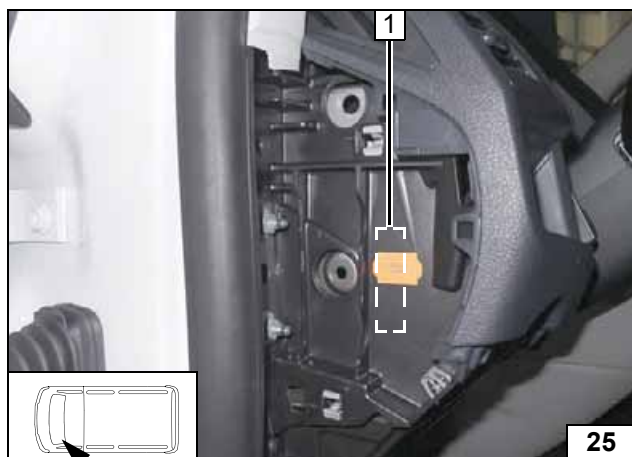

Temperature sensor T100 HTM

Fasten temperature sensor 1 with double-sided adhesive tape.



Installing temperature sensor

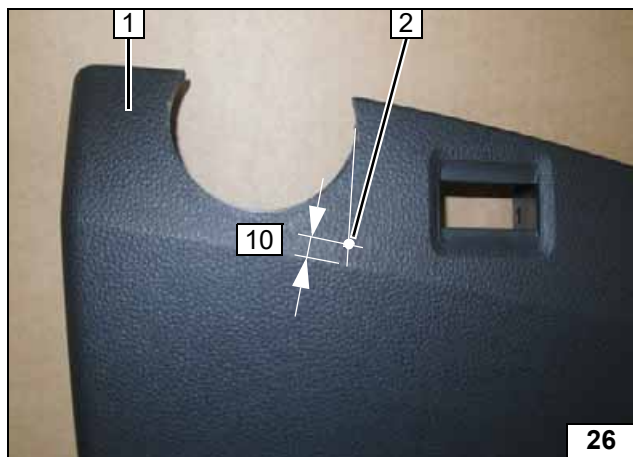

Operation indicator option for T6

- 1 Instrument panel trim
- 2 Copy hole pattern, drill Ø8.5 hole

Installing operation indicator

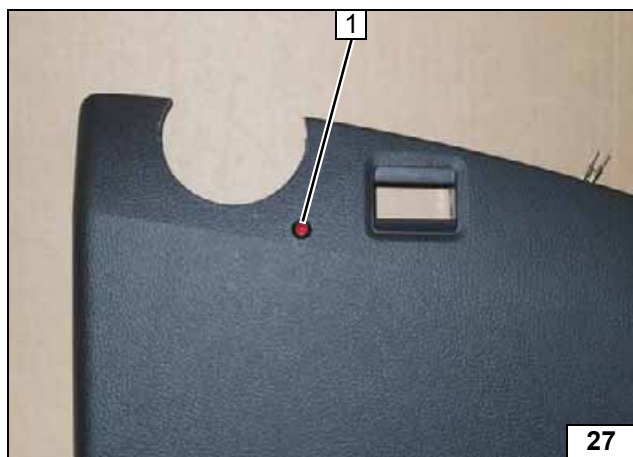

- 1 Operation indicator

Installing operation indicator

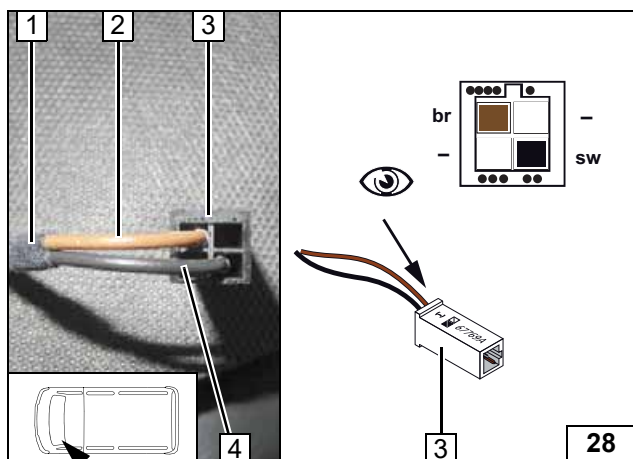

- 1 Operation indicator wiring harness
- 2 Brown (br) wire of pin 4
- 3 4-pin female connector
- 4 Black (sw) wire of pin 2

Mounting and connecting female plug

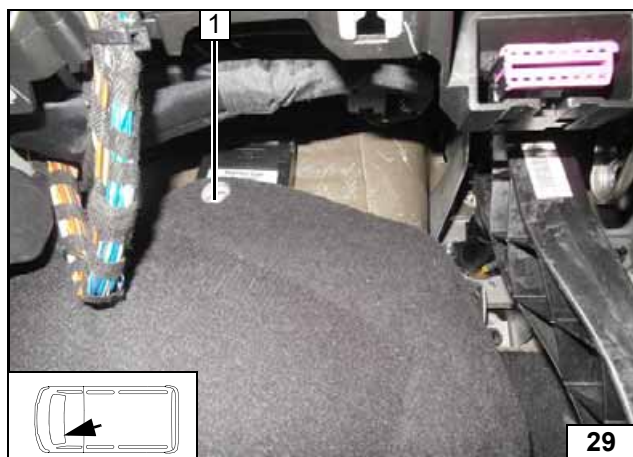

ThermoCall Option for T6

Fasten receiver 1 with double-sided adhesive tape behind the mat in the footwell.



Installing receiver

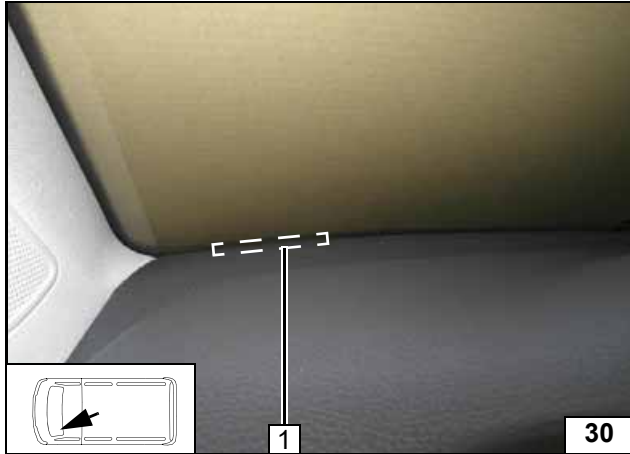

1 Aerial (optional)

Mounting
aerial



Fan Controller for Amarok

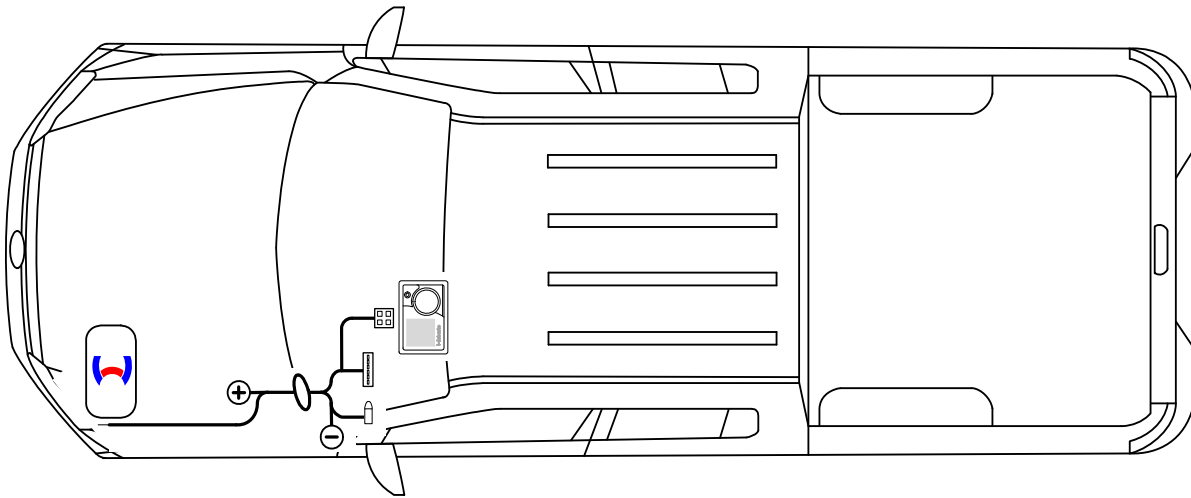

Wiring harness routing diagram



System wiring diagram for Amarok

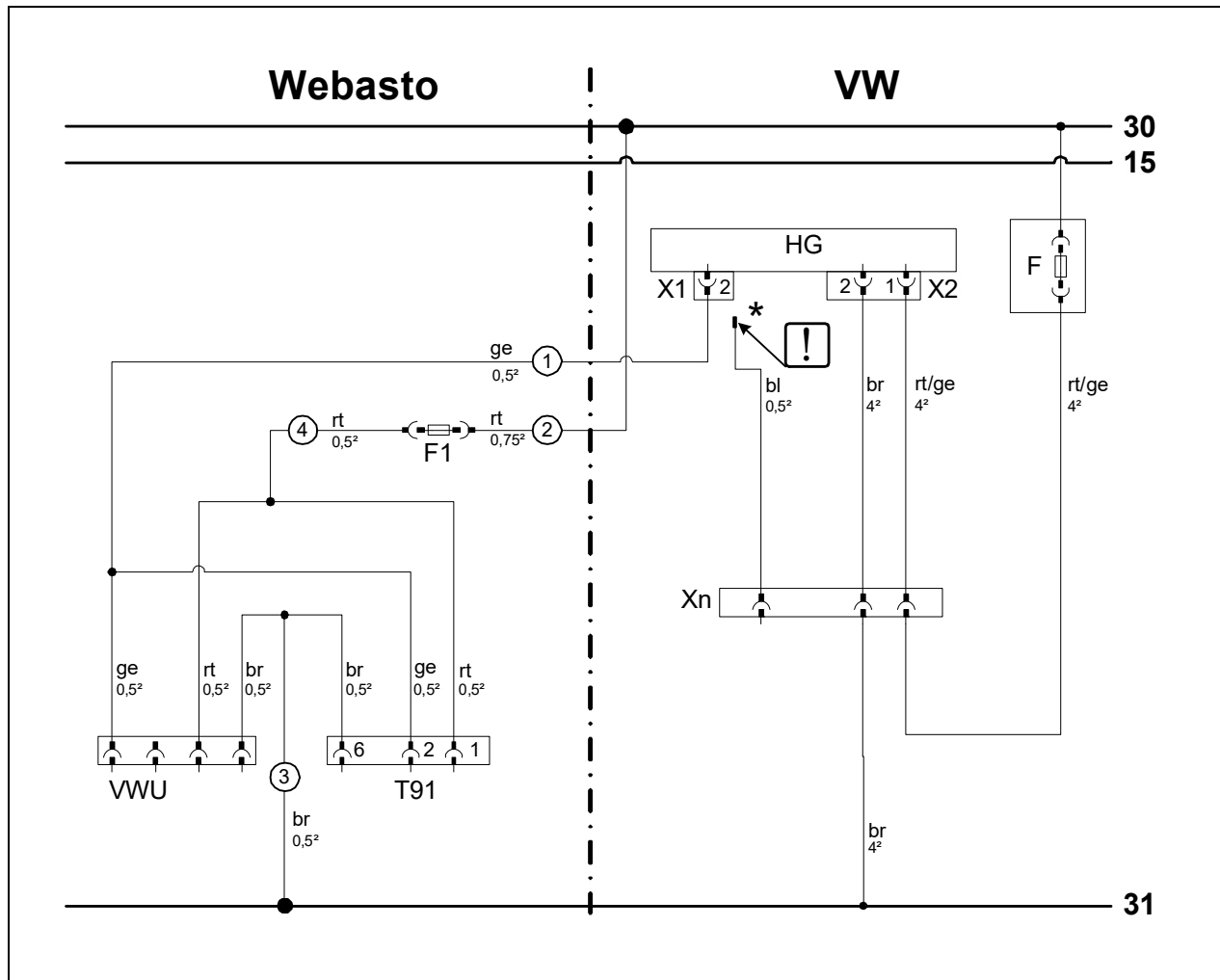

System wiring diagram for Climatronic

Webasto components		Vehicle components		Colours and symbols	
F1	1A fuse	F	Heater fuse	rt	red
VWU	4-pin connector of digital timer / MultiControl CAR	HG	TT-Evo heater (OE)	ge	yellow
		X1	6-pin heater connector	br	brown
		X2	2-pin heater connector	bl	blue
T91	6-pin connector of Telestart receiver	Xn	17-pin connector		
				*	if present
					Insulate wire end and tie back
				Wiring colours may vary.	

Legend

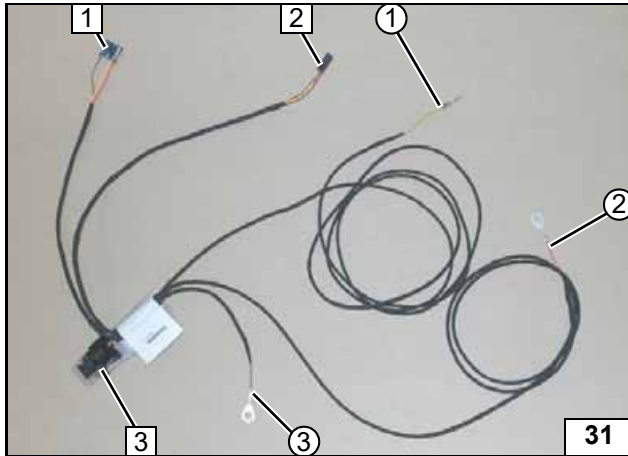
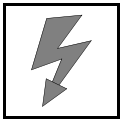

Power supply connection for Amarok

Wire sections retain their numbering in the entire document.

- 1 6-pin female connector, connection of Telestart option
- 2 4-pin female connector, connection of MultiControl CAR / ThermoCall option
- 3 Fuse F1
- ① Yellow (ge) wire of signal line
- ② Red (rt) wire of positive connection
- ③ Brown (br) wire of earth connection

View of up-grade wiring harness

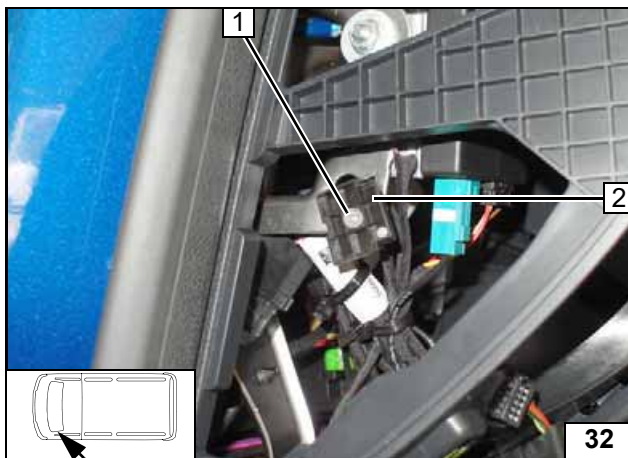

Drill a Ø4.5 hole at position 1 in original vehicle strut.

- 1 M4x16 countersunk head screw, existing hole, large diameter washer, nut
- 2 Fuse holder retaining plate

Mounting retaining plate



Produce all following electrical connections as shown in the system wiring diagram.

- 1 Protective cap, 1A fuse F1 mounted
- 2 Fuse holder

Installing fuse holder

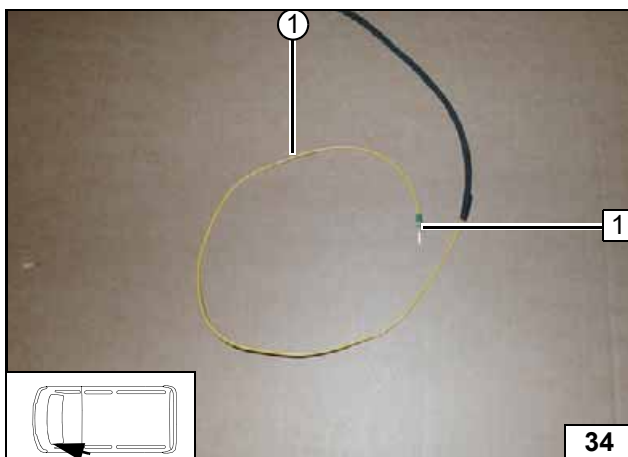

Route yellow (ge) wire ① and positive wire of upgrade wiring harness in the engine compartment.

- 1 Microtimer, premounted

Routing up-grade wiring harness



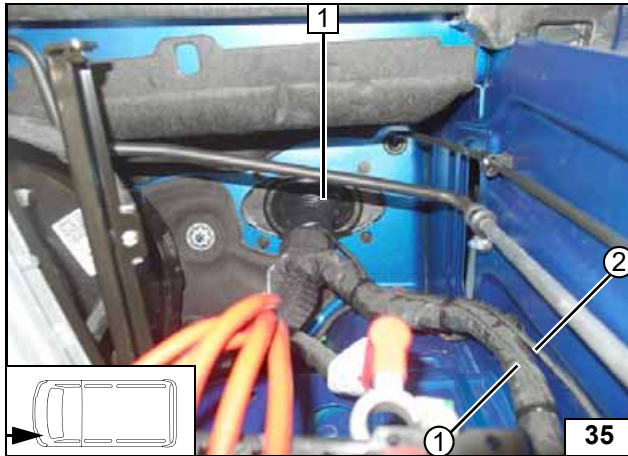
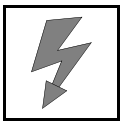

Route yellow (ge) wire ① and positive wire of upgrade wiring harness ② in the engine compartment.

- 1 Passenger compartment protective rubber plug, wrap with new insulating tape



Wiring harness pass through

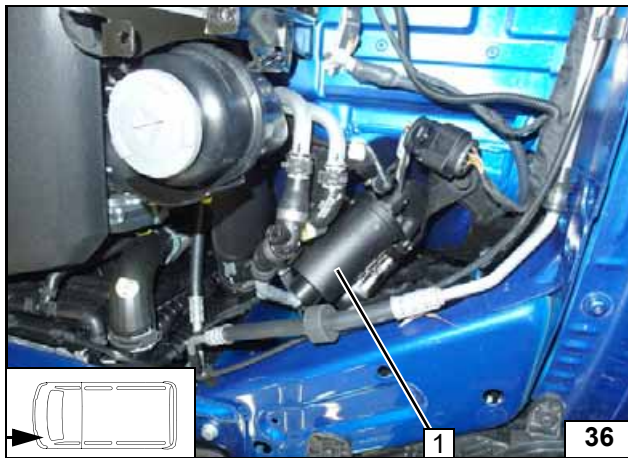

- 1 Combustion air intake silencer

Removing combustion air intake silencer

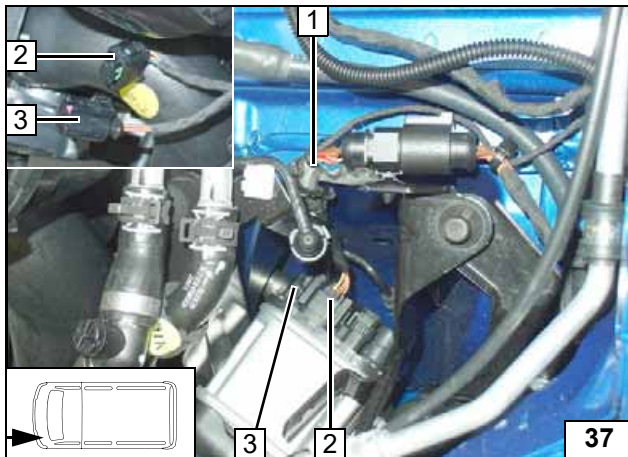

- 1 Adapter wiring harness
- 2 6-pin connector X1 of heater
- 3 2-pin connector X2 of heater

Pulling out heater connector

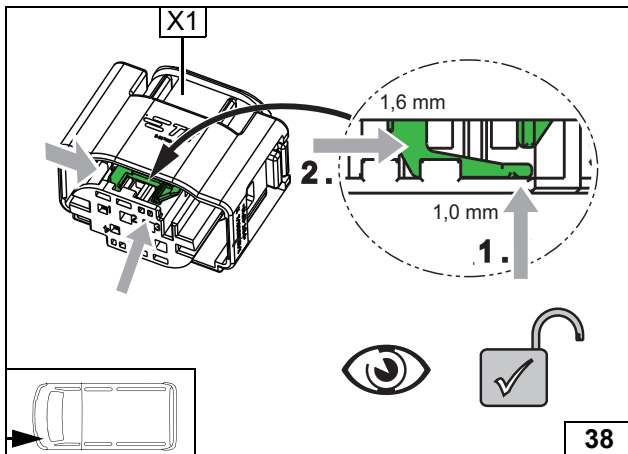

Release lock as shown!



Unlocking connector X1

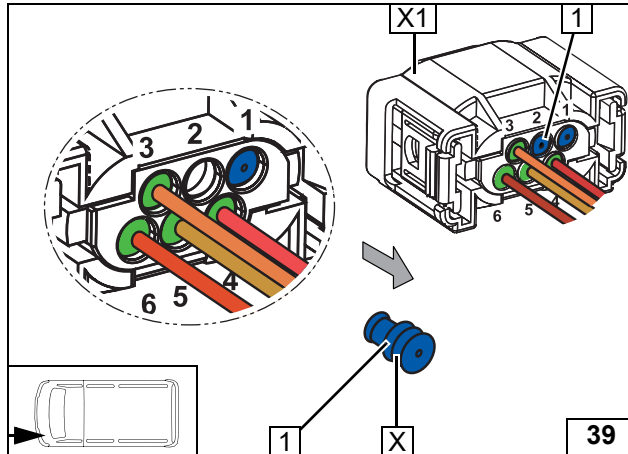
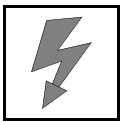

**Version 1
with sealing plug in slot 2**

Remove blue (bl) sealing plug 1 from slot 2.

X =



**Removing
sealing plug**

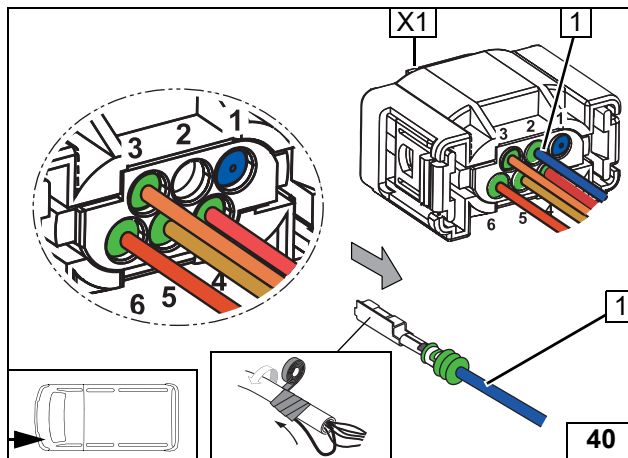

**Version 2
with blue wire in slot 2**

Remove blue (bl) wire 1 from slot 2 and in-
sulate!



**Detaching
wire**

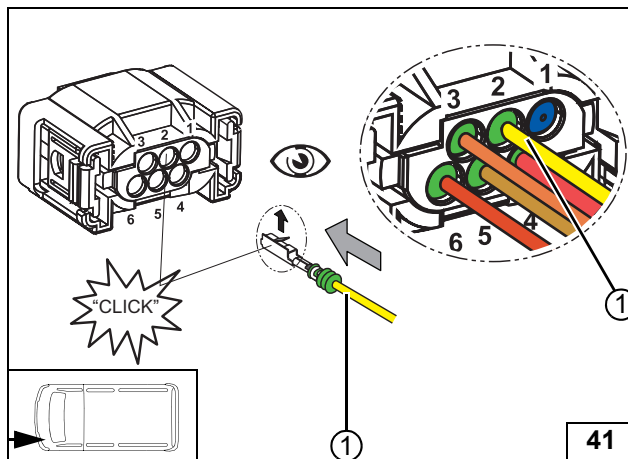

All versions

Insert yellow (ge) wire ① into slot 2.



**Installing
yellow (ge)
wire**

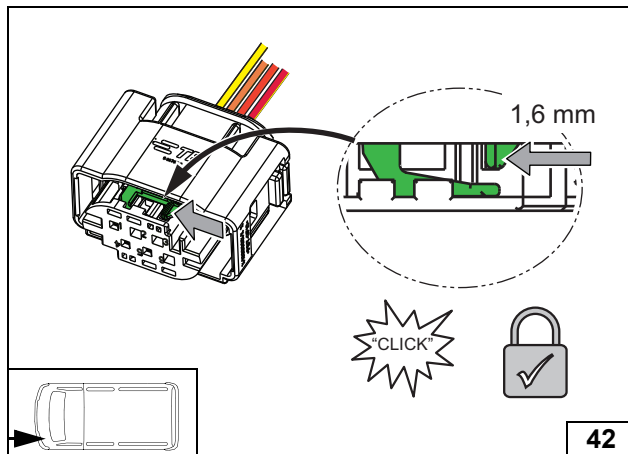

**Locking con-
nector X1**

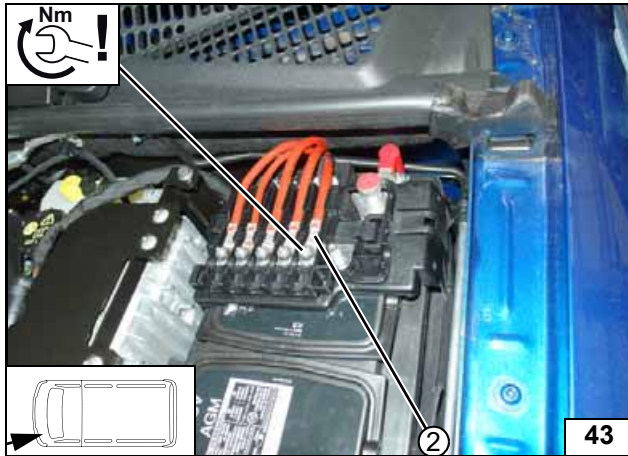

- ② Positive wire on positive battery support point



Connecting positive wire

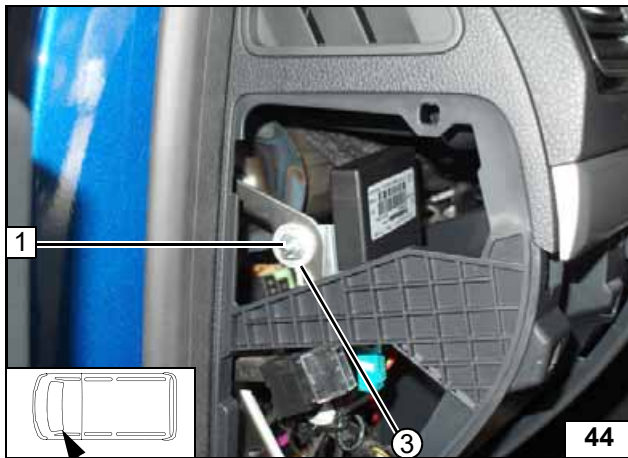

- 1 M6x12 bolt, large diameter washer, original vehicle hole, nut
- ③ Earth wire of upgrade wiring harness

Connecting earth wire

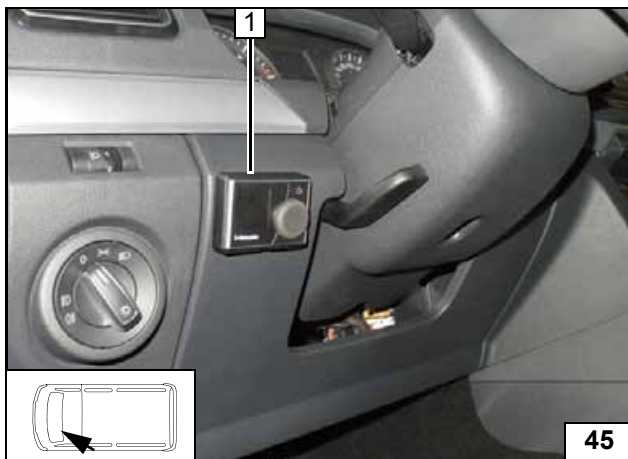

MultiControl CAR option for Amarok

- 1 Installation frame



Installing MultiControl CAR

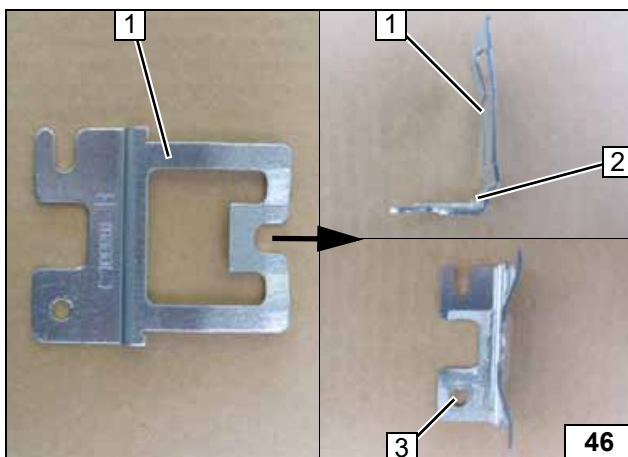

Remote option (Telestart) for Amarok

- 1 Bracket of receiver
- 2 Bend by 90°
- 3 Enlarge hole to Ø6.5



Preparing bracket

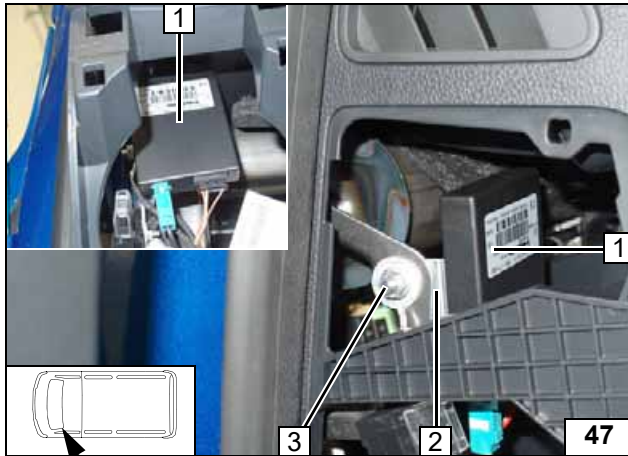

- 1 Receiver
- 2 Bracket of receiver
- 3 Existing M6x12 bolt (from earth wire connection), large diameter washer, original vehicle hole, nut

Installing receiver

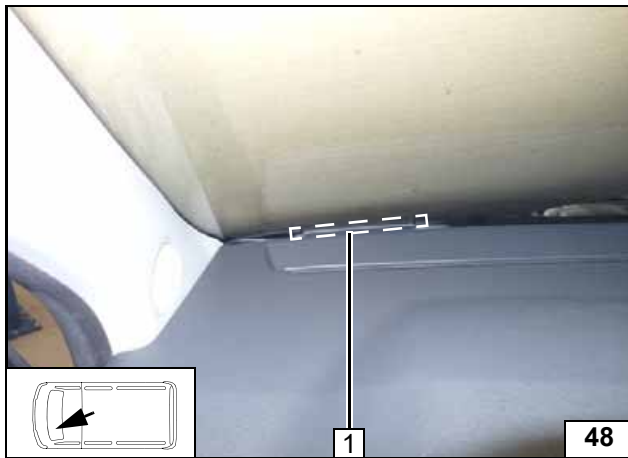

- 1 Aerial

Mounting aerial

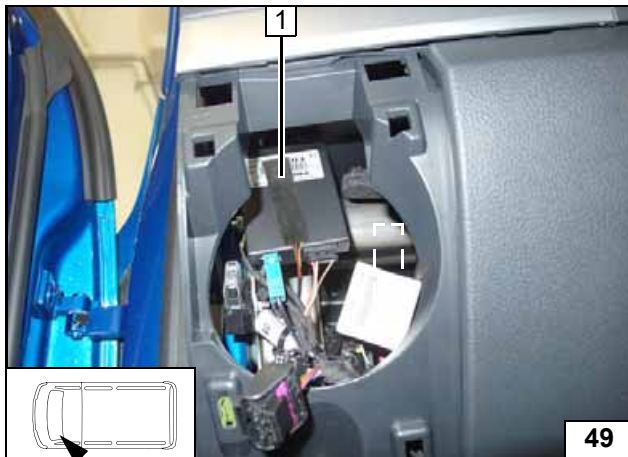

Temperature sensor T100 HTM

Fasten temperature sensor 1 with double-sided adhesive tape.



Installing temperature sensor



Operation indicator option for Amarok

Ø8.5 hole at position 1.
Be careful of components located behind!

- 1 Operation indicator



Installing operation indicator

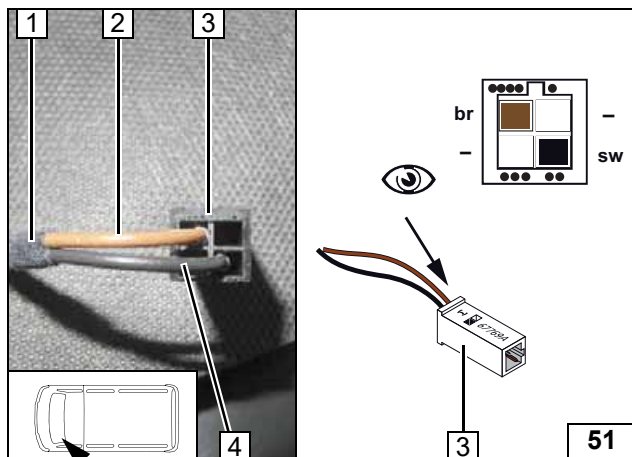

- 1 Operation indicator wiring harness
- 2 Brown (br) wire of pin 4
- 3 4-pin female connector
- 4 Black (sw) wire of pin 2

Mounting and connecting female plug



ThermoCall option for Amarok

Fasten receiver 1 with double-sided adhesive tape.



Installing receiver

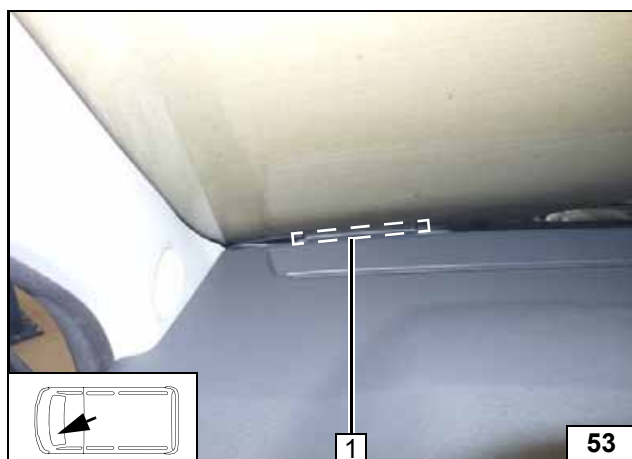

- 1 Aerial

Mounting aerial

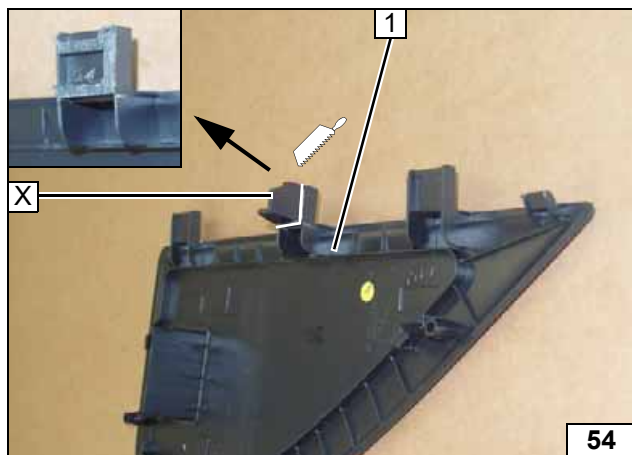

Final work

Amarok only

- 1 Instrument panel side trim on the left

X = 



**Adapting
side trim**

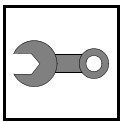

All vehicles

Reassemble the components in reverse order. Check all electrical connections for firm seating. Insulate and tie back loose lines.

- Connect the battery.
- Program MultiControl CAR, teach Telestart transmitter.
- Place the 'Switch off parking heater before refuelling' caution label near the filler point.

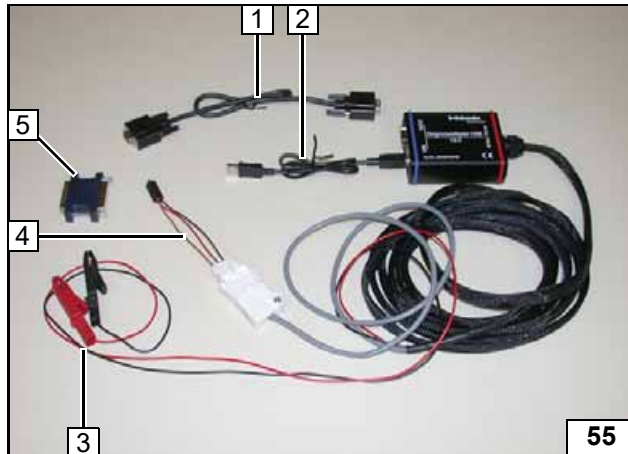

Loading the upgrade software

Use a free PC interface (serial or USB) for the communication structure for the heater control unit.

- 1 Serial connecting line
- 2 USB connecting line (here already connected to the diagnosis adapter)
- 3 Positive and earth wire (not used).
- 4 Adapter wiring harness to clock connector
- 5 Dongle for the connection to the PC (figure shows serial port)



Accessories for installation

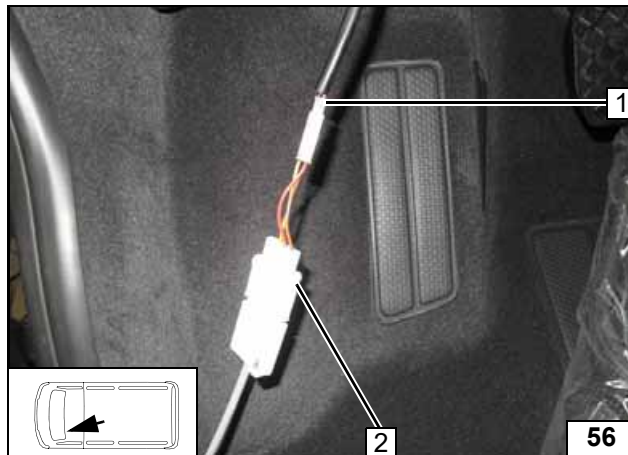

Warning:

The Webasto Thermo Test program should be closed before installing the update!

- 1 4-pin connector for control element connection
- 2 Adapter connector



Creating connection

The software should be launched as explained in the provided brief instructions



Webasto Thermo & Comfort SE
 Postfach 1410
 82199 Gilching
 Germany
 Internet: www.webasto.com
 Technical Extranet:
<http://dealers.webasto.com>

Operating instructions for Climatronic on T6

Please remove page and add to the vehicle operating instructions.

Note:

We recommend matching the heating time to the driving time.

Heating time = driving time

Example:

For a driving time of approx. 20 min. (in one direction), we recommend not exceeding a switch-on time of 20 min.

Passenger compartment monitoring, if installed, must be deactivated in addition to the vehicle settings for the heating operation.

For instructions on deactivation, please refer to the operating instructions of the vehicle.

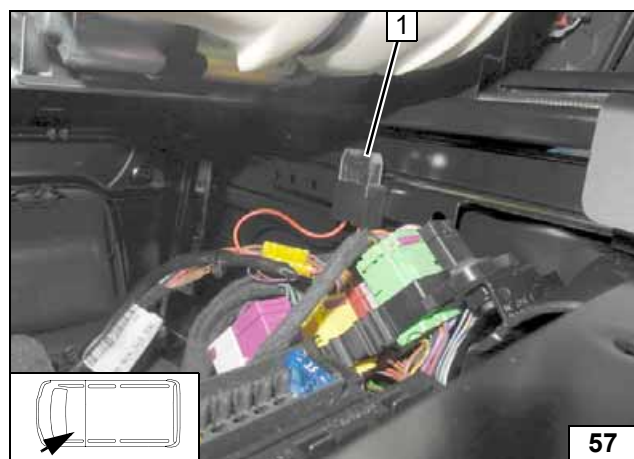

- 1 1A control element fuse F1 (single seat box, driver's seat)

Passenger compartment fuse



Operating instructions for Climatronic on Amarok

Please remove page and add to the vehicle operating instructions.

Note:

We recommend matching the heating time to the driving time.

Heating time = driving time

Example:

For a driving time of approx. 20 min. (in one direction), we recommend not exceeding a switch-on time of 20 min.

Passenger compartment monitoring, if installed, must be deactivated in addition to the vehicle settings for the heating operation.

For instructions on deactivation, please refer to the operating instructions of the vehicle.



1 1A control element fuse F1

Passenger compartment fuse

